



W341-LX Quick Installation Guide

Fifth Edition, July 2009

1. Overview

The W341 embedded computer has four RS-232/422/485 serial ports, one relay output, one 10/100 Mbps Ethernet port, one embedded wireless LAN card, an SD slot for storage expansion, two USB 2.0 host ports, and one relay output channel, making the W341 ideal for your wireless embedded applications.

2. Package Checklist

Before installing the W341, please verify that the package contains the following items:

- 1 W341 embedded computer
- Wall mounting kit
- Quick Installation Guide
- Document & Software CD
- Ethernet Cable: RJ45 to RJ45 cross-over cable, 100 cm
- CBL-4PINDB9F-100: 4-pin header to DB9 female console port cable, 100 cm
- WLAN Antenna
- Universal Power Adaptor
- Product Warranty Statement

Optional Accessories

- 35 mm DIN-Rail Mounting Kit (DK-35A)

Please notify your sales representative if any of the above items are missing or damaged.

3. W341 Panel Layout

The W341 comes with four RS-232/422/485 serial ports, one RS-232 console port, one 10/100 Mbps LAN port, one SD socket, a relay output, and an embedded wireless LAN. The following figures show the panel layouts of the W341.

P/N: 1802003410014

Top View

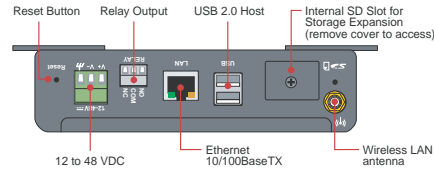

Front View

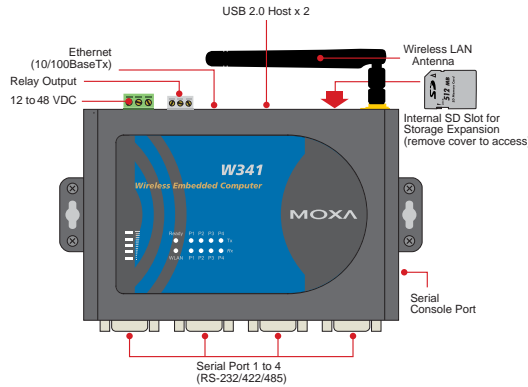

Rear View

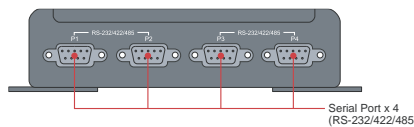

LED Indicators

The following table describes the LED indicators located on the front panel of the W341.

LED Name	Color	LED Function
Ready	Green	Power is on and functioning normally
	Off	Power is off or power error exists
SD	Green	SD card detected
	Off	No SD card detected
WLAN	Green	ON: WLAN is ready
	Off	Blinking: WLAN IP conflict or DHCP server not responding
Signal Strength (5 LEDs)	Green	Number of glowing LEDs indicates signal strength:
		5: Excellent 4: Very good

		3: Good 2: Fair 1: Bad
	Off	No signal or WLAN connection failed
LED Name	Color	LED Function
LAN	Orange	10 Mbps Ethernet link
	Green	100 Mbps Ethernet link
	Off	Disconnected or short circuit
TxD (P1-P4)	Green	Serial port (1/2/3/4) transmitting data
	Off	Serial port (1/2/3/4) not transmitting data
RxD (P1-P4)	Yellow	Serial port (1/2/3/4) receiving data
	Off	Serial port (1/2/3/4) not receiving data

4. Installing the W341

Wall or Cabinet Mounting

The W341 comes with two metal attachment plates for attaching the embedded computer to a wall or the inside of a cabinet. First, use two screws per bracket to attach the brackets to the rear of the W341. Next, use two screws per bracket to attach the W341 to a wall or cabinet.

The heads of the screws should be less than 6.0 mm in diameter, and the shafts should be less than 3.5 mm in diameter, as shown by the figure at the right.

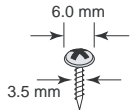

DIN-Rail Mounting

DIN-rail attachments can be purchased separately to attach the product to a DIN-rail. When snapping the attachments to the DIN-rail, make sure that the stiff metal springs are at the top.

Wall or Panel Mounting

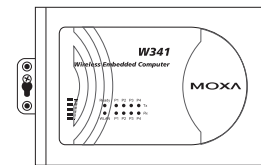

DIN-Rail Mounting

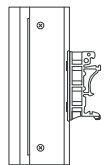

5. Connector Description

Power Connector

Connect the 12 to 48 VDC LPS or Class 2 power line to the W341's terminal block. If the power is properly supplied, the Power LED will light up. The OS is ready when the Ready LED glows a solid green.

Grounding the W341

Grounding and wire routing help limit the effects of noise due to electromagnetic interference (EMI). Run the ground connection from the ground screw to the grounding surface prior to connecting the power.

ATTENTION

This product is intended to be mounted to a well-grounded mounting surface such as a metal panel.

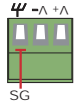

SG:

The Shielded Ground (sometimes called Protected Ground) contact is the left most contact of the 3-pin power terminal block connector when viewed from the angle shown here. Connect the SG wire to an appropriate grounded metal surface.

Ethernet Ports

The 10/100 Mbps Ethernet port uses RJ45 connectors.

Pin	Signal
1	ETx+
2	ETx-
3	ERx+
6	ERx-

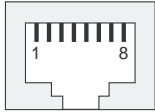

Serial Ports

The four serial ports (P1 to P4) use male DB9 connectors. Each port can be configured by software for RS-232, RS-422, or RS-485. The pin assignments for the ports are shown in the following table:

Pin	RS-232	RS-422	RS-485 (4-wire)	RS-485 (2-wire)
1	DCD	TxDA(-)	TxDA(-)	---
2	RxD	TxDB(+)	TxDB(+)	---
3	TxD	RxDB(+)	RxDB(+)	DataB(+)
4	DTR	RxDA(-)	RxDA(-)	DataA(-)
5	GND	GND	GND	GND
6	DSR	---	---	---
7	RTS	---	---	---
8	CTS	---	---	---

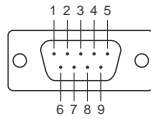

Relay Output

The W341 includes a relay output channel. There is a 3-pin terminal block for the relay output connection, with pinouts as shown in the figure at the right.

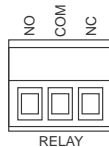

SD Interface

The W341 has an internal SD slot for storage expansion. The SD slot allows users to plug in a Secure Digital (SD) memory card compliant with the SD 1.0 standard for up to 1 GB of additional memory space, or a Secure Digital High Capacity (SDHC) memory card compliant with the SD 2.0 standard for up to 16 GB of additional memory space. To install an SD card, first use a screw driver to remove the SD slot cover

to access the slot. The slot is located on the top panel next to the antenna. Plug the SD card directly into the socket, and then replace the SD slot cover. The SD card will be mounted at `/mnt/sd`. To remove the SD card from the slot, press the SD card in slightly with your finger, and then remove your finger to cause the card to spring out partially. You may now grasp the top of the card with two fingers and pull it out.

Console Port

The serial console port is a 4-pin pin-header RS-232 port. It is designed for serial console terminals, which are useful for viewing boot-up messages. Use the CBL-4PINDB9F-100 cable included with the product to connect a PC to the W341's serial console port.

Reset

Press the **Reset** button continuously for at least 5 seconds to load the factory default configuration. After the factory default configuration has been loaded, the system will reboot automatically. The Ready LED will blink on and off for the first 5 seconds, and then maintain a steady glow once the system has rebooted.

USB

The USB 2.0 Host port now supports a USB storage device driver. The USB storage will be mounted at `/mnt/usbstorage`.

Real-time Clock

The W341's real-time clock is powered by a lithium battery. We strongly recommend that you do not replace the lithium battery without help from a qualified Moxa support engineer. If you need to change the battery, contact the Moxa RMA service team.

ATTENTION

There is a risk of explosion if the battery is replaced by an incorrect type of battery.

6. Powering on the W341

To power on the W341, connect the "terminal block to power jack converter" to the W341's DC terminal block (located on the left rear panel), and then connect the power adaptor. Note that the Shielded Ground wire should be connected to the right most pin of the terminal block. It takes about 30 seconds for the system to boot up. Once the system is ready, the Ready LED will light up.

Power Consumption

- 600 mA @ 12 VDC with no USB devices attached
- 1.2A @ 12 VDC with USB devices on each port at max spec 500 mA @ 5 VDC

7. Connecting the W341 to a PC

There are two ways to connect the W341 to a PC: (1) through the serial console port, or (2) by Telnet over the network. The COM settings for

the serial console port are: **Baudrate = 115200 bps, Parity = None, Data bits = 8, Stop bits = 1, Flow Control = None.**

ATTENTION

Use the CBL-4PINDB9F-100 cable included with the product to connect a PC to the W311/321's serial console port. Remember to choose **VT100** terminal type.

To use Telnet, you will need to know the W341's IP address and netmask. The default LAN settings are shown below. For first-time configuration, you may find it convenient to use a cross-over Ethernet cable to connect directly from the PC to the W341.

	Default IP Address	Netmask
LAN 1	192.168.3.127	255.255.255.0
LAN 2 (wireless)	192.168.4.127	255.255.255.0

Once the W341 is powered on, the Ready LED will light up, and a login page will open. Use the following default Login name and Password to proceed. The defaults are:

Login: root

Password: root

8. Configuring the Ethernet Interface

If you use the console cable for first-time configuration of the network settings, use the following commands to edit the interfaces file:

```
# ifdown -a
//Disable LAN1 interface first, before you reconfigure
The LAN settings. LAN 1 = eth0//
# vi /etc/network/interfaces
//check the LAN interface first//
```

After the boot setting of the LAN interface has been modified, use the following commands to activate the LAN settings immediately:

```
# sync ; ifup -a
```

NOTE: Refer to the W341 User's Manual for information on how to configure the WLAN interface, and for other configuration information.

MOXA®

Click here for online support:
www.moxa.com/support

The Americas: +1-714-528-6777 (toll-free: 1-888-669-2872)
 Europe: +49-89-3 70 03 99-0
 Asia-Pacific: +886-2-8919-1230
 China: +86-21-5258-9955 (toll-free: 800-820-5036)

© 2009 Moxa Inc. All rights reserved.
Reproduction without permission is prohibited.