

MiiNePort W1 Schematic Design Guide

First Edition, April. 2012

www.moxa.com/product



© 2012 Moxa Inc. All rights reserved.
Reproduction without permission is prohibited.

MiiNePort W1 Schematic Design Guide

The software described in this manual is furnished under a license agreement and may be used only in accordance with the terms of that agreement.

Copyright Notice

Copyright ©2012 Moxa Inc.
All rights reserved.
Reproduction without permission is prohibited.

Trademarks

The MOXA logo is a registered trademark of Moxa Inc.
All other trademarks or registered marks in this manual belong to their respective manufacturers.

Disclaimer

Information in this document is subject to change without notice and does not represent a commitment on the part of Moxa.

Moxa provides this document as is, without warranty of any kind, either expressed or implied, including, but not limited to, its particular purpose. Moxa reserves the right to make improvements and/or changes to this manual, or to the products and/or the programs described in this manual, at any time.

Information provided in this manual is intended to be accurate and reliable. However, Moxa assumes no responsibility for its use, or for any infringements on the rights of third parties that may result from its use.

This product might include unintentional technical or typographical errors. Changes are periodically made to the information herein to correct such errors, and these changes are incorporated into new editions of the publication.

Technical Support Contact Information

www.moxa.com/support

Moxa Americas

Toll-free: 1-888-669-2872
Tel: +1-714-528-6777
Fax: +1-714-528-6778

Moxa Europe

Tel: +49-89-3 70 03 99-0
Fax: +49-89-3 70 03 99-99

Moxa China (Shanghai office)

Toll-free: 800-820-5036
Tel: +86-21-5258-9955
Fax: +86-10-6872-3958

Moxa Asia-Pacific

Tel: +886-2-8919-1230
Fax: +886-2-8919-1231

The following topics are covered:

- Pin Description**
- System Power Circuit Design**
- RS-232 Circuit Design**
- RS485-2W Data Port Circuit Design**
- RS485-4W Circuit Design**
- SW/HW Reset and Ready/Fault LEDs Circuit Design**
- WLAN Strength and Link status LEDs Circuit Design**
- DIO Circuit Design and DC Characteristics**
- Ethernet Circuit Design**

Pin Description

- **MiNePort W1 (TOP View)**

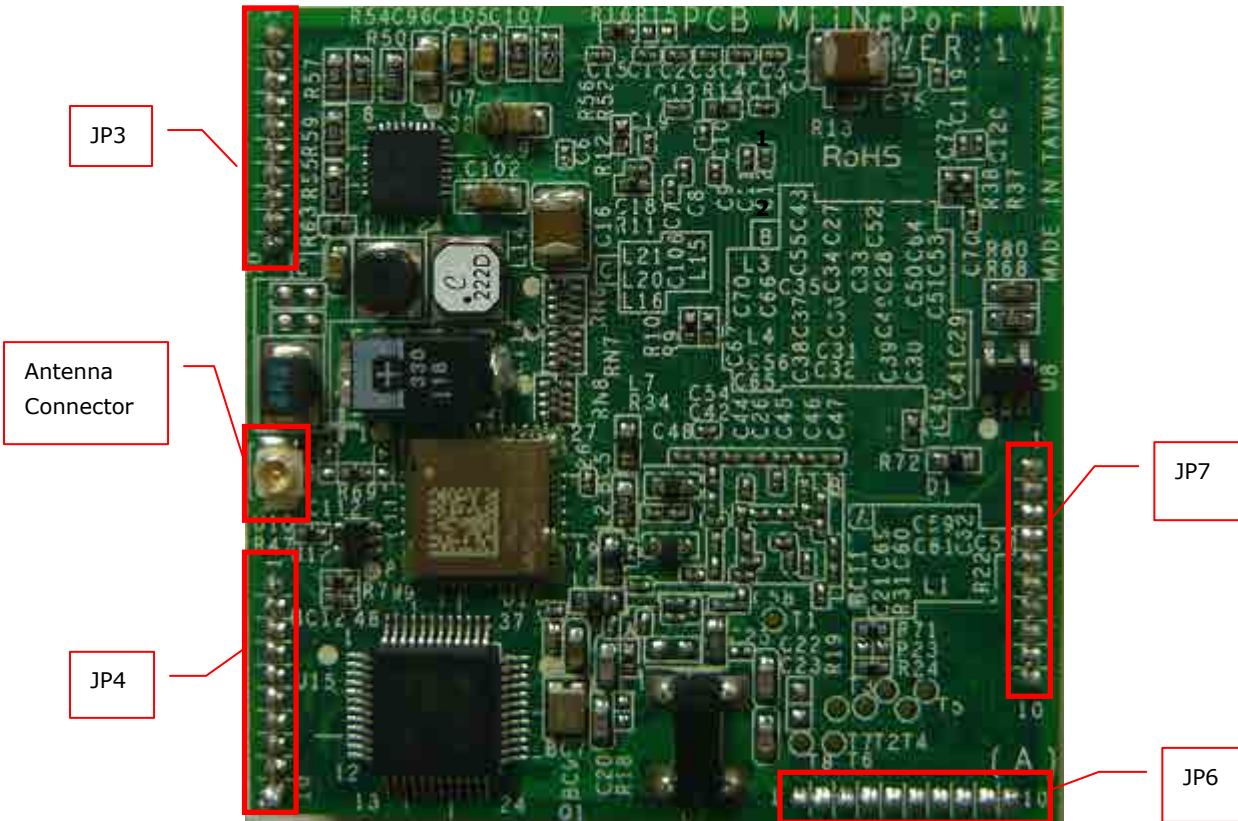

- **MiNePort W1 (Bottom View)**

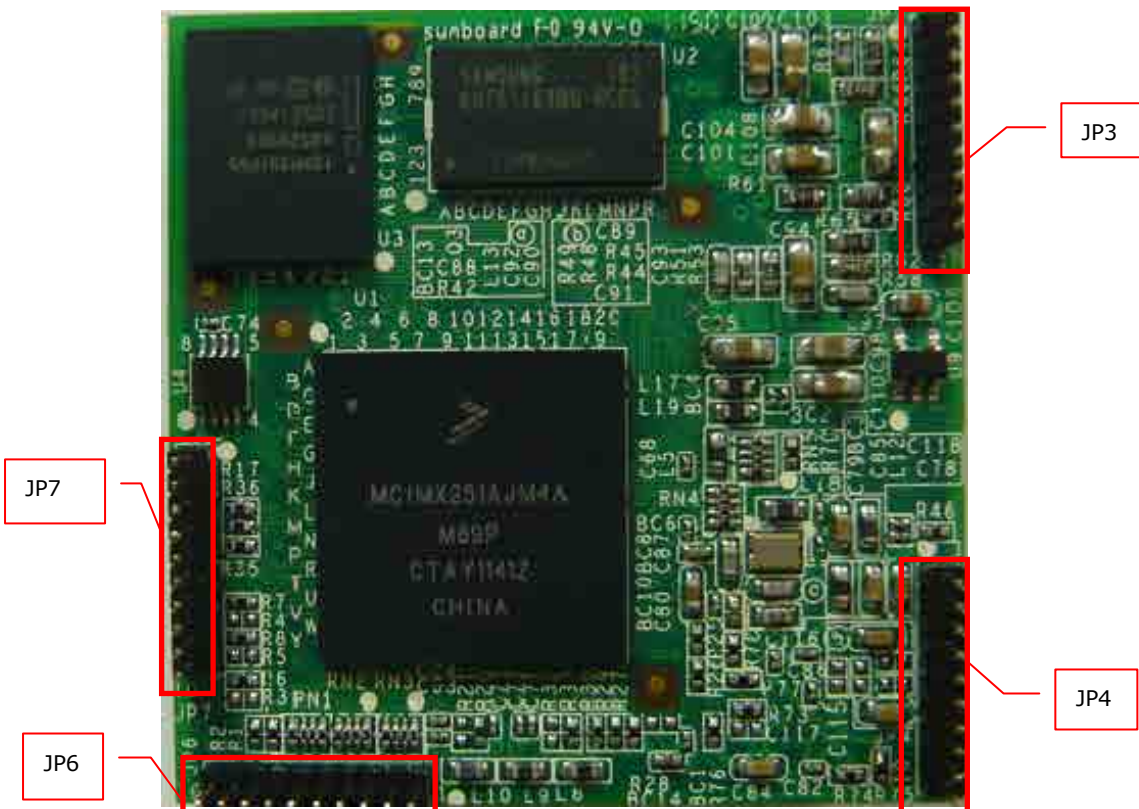

Pin	JP3	JP4	JP6	JP7
1	N.C.	Eth_10M_LED	PIO0	Data_LTXD
2	N.C.	Eth_100M_LED	PIO1	Data_LRTS
3	N.C.	Eth_Rx+	PIO2	Data_LDTR
4	READY_LED	Eth_Rx-	PIO3	Data_LRXD
5	FAULT_LED	Eth_Tx_Center	PIO4	Data_LCTS
6	HW_RESET	Eth_Tx_Center	PIO5	Data_LDSR
7	SW_RESET	Eth_Tx+	PIO6	Data_LDCD
8	WLAN_Link_LED	Eth_Tx-	PIO7	N.C.
9	Vin(3.3~5V)	GND	Debug_LTXD	Debug_LCTS
10	Vin(3.3~5V)	GND	Debug_LRTS	Debug_LRXD

System Power Circuit Design

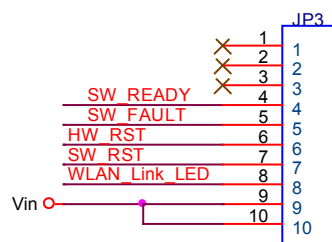

Symbol	Parameter	Min	Nominal	Max	Units
Vin	Supply Voltage	3.22	3.3~5	5.25	V

RS-232 Circuit Design

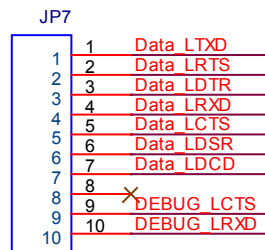
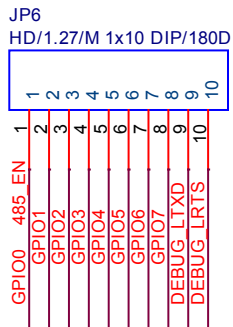

HD/1.27/M 1x10 DIP/180D

■ Debug Port

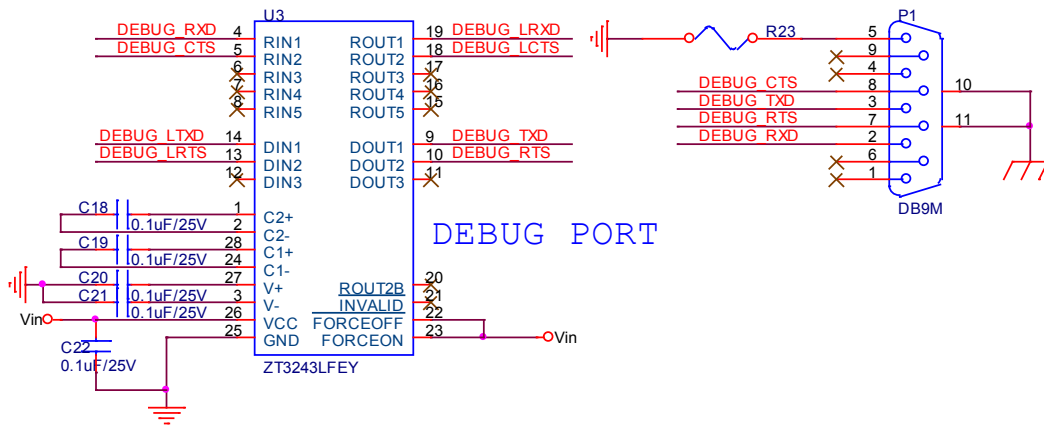

■ Data Port

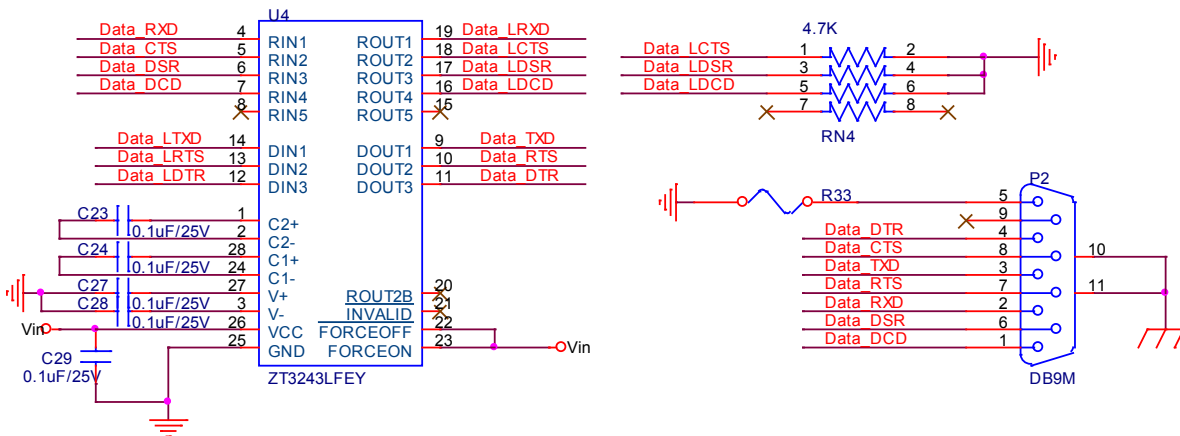

RS485-2W Data Port Circuit Design

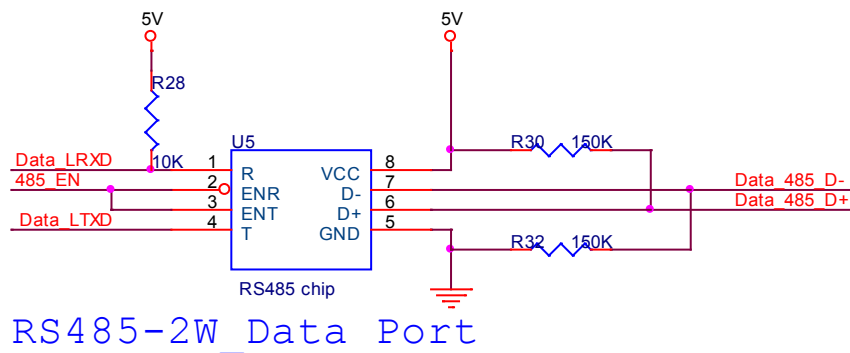

RS485-4W Circuit Design

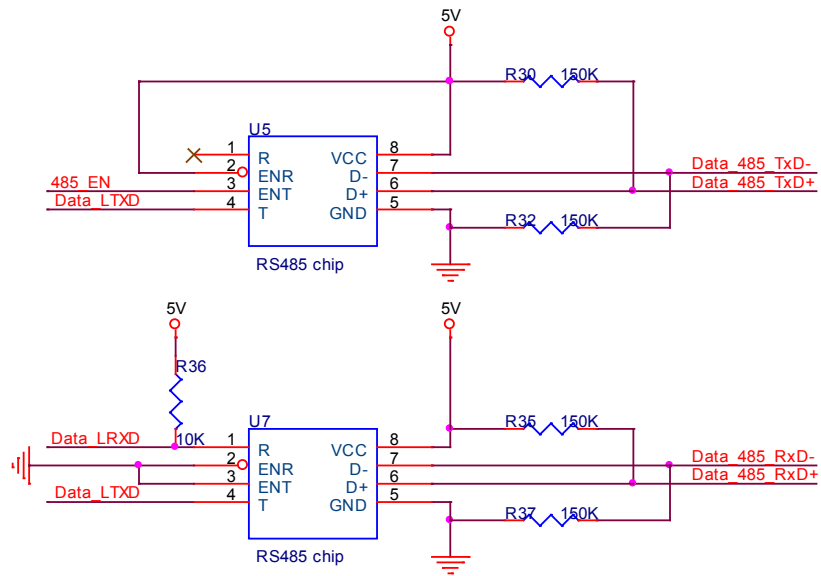

RS485-4W_Data Port

SW/HW Reset and Ready/Fault LEDs Circuit Design

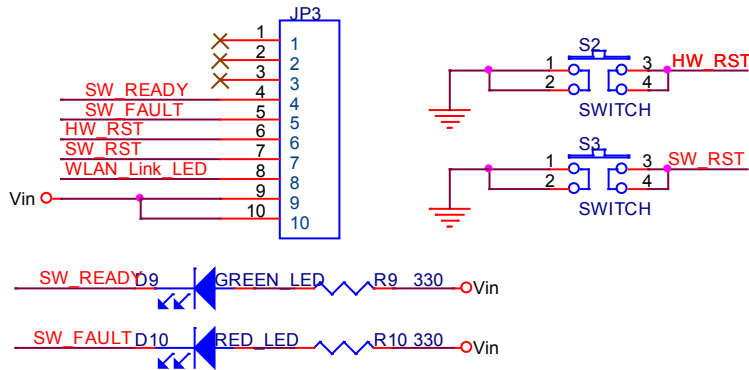

WLAN Strength and Link status LEDs Circuit Design

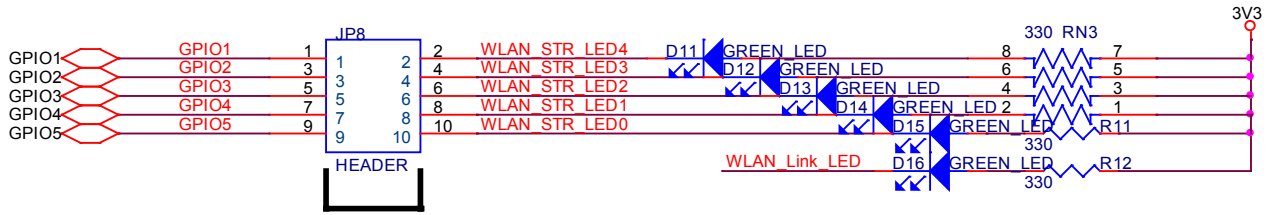
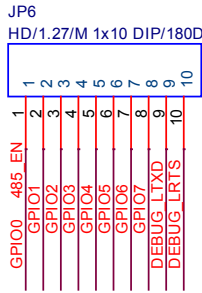

Short for WLAN Strength LED

DIO Circuit Design and DC Characteristics

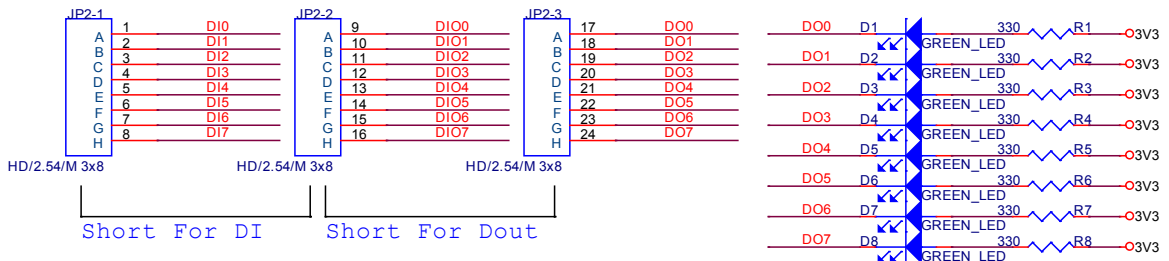
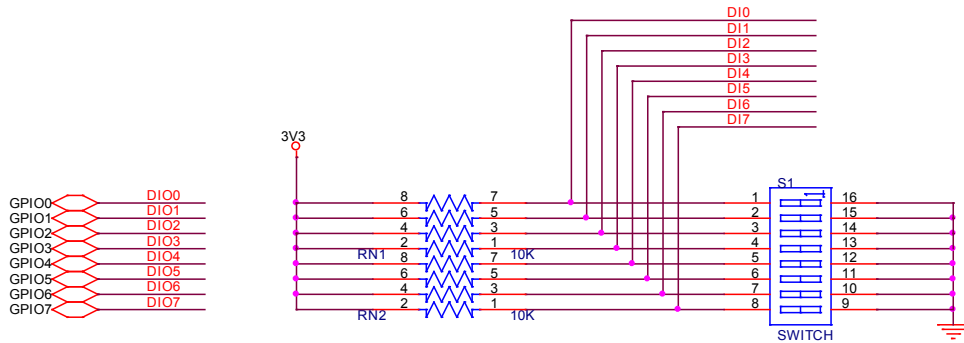
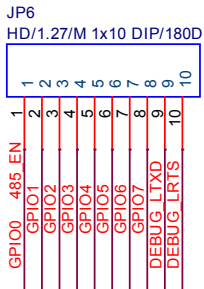

Symbol	Parameter	Min	Typ.	Max	Units
VIL	Input Low Voltage	-0.3	N/A	1	V
VIH	Input High Voltage	2	N/A	3.6	V
VOL	Output Low Voltage	N/A	N/A	0.4	V
VOH	Output High Voltage	2.4	N/A	N/A	V
IOL/IOH	Driving Strength	N/A	8	N/A	mA

Ethernet Circuit Design

