



MGate™ EIP3270 and EIP3270I Quick Installation Guide

First Edition, April 2009

1. Overview

The MGate™ EIP3270 and EIP3270I are 2-port DF1 to EtherNet/IP gateways that provide protocol conversion for users who need to connect Rockwell Automation PLCs to an EtherNet/IP network. The MGate™ EIP3000 series products support up to 8 EtherNet/IP clients and 8 EtherNet/IP servers simultaneously. Each client can send up to 16 requests at one time.

2. Package Checklist

Before installing the MGate™ EIP3270 or EIP3270I DF1 to EtherNet/IP gateway, verify that the package contains the following items:

- MGate™ EIP3270 or EIP3270I DF1 to EtherNet/IP gateway
- Document & Software CD
- MGate™ EIP3270 and EIP3270I Quick Installation Guide
- Product Warranty Statement

Please notify your sales representative if any of the above items is missing or damaged.

3. Hardware Introduction

LED Indicators

Name	Color	Function
PWR1	Red	Power is being supplied to the power input
PWR2	Red	Power is being supplied to the power input
RDY	Red	(steady) Power is on and the unit is booting up (blinking) IP conflict, DHCP or BOOTP server did not respond properly, or a relay output occurred
	Green	(steady) Power is on and the unit is functioning normally (blinking) Unit is responding to Locate function
	Off	Power is off or power error condition exists
Ethernet	Orange	10 Mbps Ethernet connection
	Green	100 Mbps Ethernet connection
	Off	Ethernet cable is disconnected or has a short
P1, P2	Orange	Serial port is receiving data
	Green	Serial port is transmitting data
	Off	Serial port is not transmitting or receiving data

P/N: 1802032701010

The MGate™ EIP3270 and EIP3270I each provide two DB9 ports to connect to serial devices.

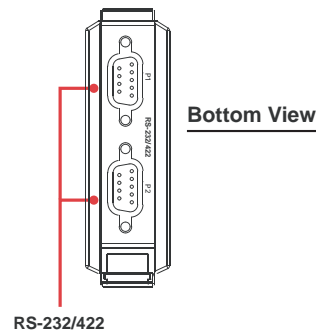
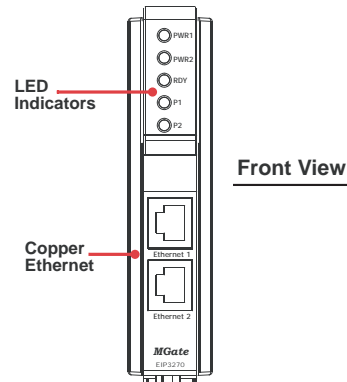
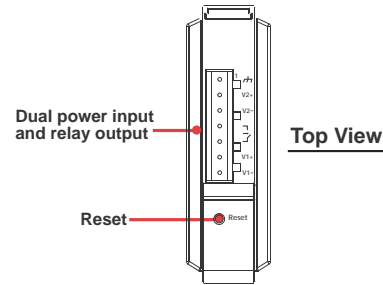

Reset Button

The reset button is used to load factory defaults. Use a pointed object such as a straightened paper clip to hold the reset button down for five seconds. Release the reset button when the Ready LED stops blinking.

4. Hardware Installation Procedure

STEP 1: Use a standard straight-through Ethernet cable to connect the MGate to a network hub or switch

STEP 2: Connect your device to the MGate serial port

STEP 3: Mount the MGate on a DIN-rail

STEP 4: Connect the power source to power input

5. Software Installation Information

To install MGate™ Manager, insert the MGate™ Document & Software CD into your PC's CD-ROM drive. Once the installation window opens, click the Installation button and follow the onscreen instructions. For more detailed information about MGate™ Manager, click the Documents button and select the MGate™ EIP3000 User's Manual.

6. Pin Assignments

Ethernet Port (RJ45)

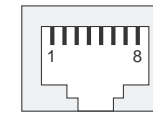

Pin	Signals
1	Tx+
2	Tx-
3	Rx+
6	Rx-

Serial Port (Male DB9)

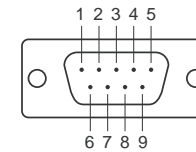

Pin	RS-232	RS-422
1	DCD	TxD-(A)
2	RxD	TxD+(B)
3	TxD	RxD+(B)
4	DTR	RxD-(A)
5	GND	GND
6	DSR	---
7	RTS	---
8	CTS	---
9	---	---

Power Input and Relay Output Pinouts

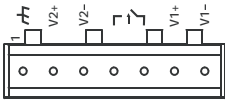

	V2+	V2-		V1+	V1-
Shielded Ground	DC Power Input 1	DC Power Input 1	Relay output	DC Power Input 2	DC Power Input 2

7. Specifications

Power Requirements

Power Input	12 to 48 VDC
Power Consumption	EIP3270: 435 mA@12 VDC, 145 mA@48 VDC EIP3270I: 510 mA@12 VDC, 150 mA@48 VDC
Operating Temperature	Standard: 0 to 55°C (32 to 131°F) Wide Temp. Model: -40 to 75°C (-40 to 167°F)
Operating Humidity	5 to 95% RH
Dimensions	29 × 124.5 × 89.2 mm

MOXA® [Click here for online support: www.moxa.com/support](http://www.moxa.com/support)

The Americas: +1-714-528-6777 (toll-free: 1-888-669-2872)
 Europe: +49-89-3 70 03 99-0
 Asia-Pacific: +886-2-8919-1230
 China: +86-21-5258-9955 (toll-free: 800-820-5036)

© 2009 Moxa Inc. All rights reserved.
 Reproduction without permission is prohibited.