

# **Moxa AirWorks AWK-1100**

---

## **Quick Installation Guide**

**Second Edition, October 2008**



© 2008 Moxa Inc. All rights reserved.  
Reproduction without permission is prohibited.

P/N: 1802011000011

# Overview

The AWK-1100 enables wireless users to access network resources wirelessly. It can authenticate and authorize wireless users by IEEE 802.1X and RADIUS, and communicates with a back-end RADIUS (Remote Authentication User Dial-In Service) server to see if a wireless user is allowed to access the wireless network.

The AWK-1100 is rated to operate at temperatures ranging from 0 to 60°C, and is rugged enough for any harsh industrial environment. It can be installed easily using either DIN-Rail mounting or distribution boxes. The DIN-rail mounting ability, wide operating temperature range, and IP30 case with LED indicators make the plug-and-play AWK-1100 a reliable solution for your industrial wireless applications.

## Package Checklist

The AWK-1100 is shipped with the following items. If any of these items is missing or damaged, please contact your customer service representative for assistance.

- 1 × AWK-1100 802.11g/b Wireless AP/Bridge/Client
- 2 × Swivel Type Antenna (2 dBi RP-SMA)
- Quick Installation Guide
- Documentation & Software CD; includes User's Manual and Windows Utility
- Warranty Booklet

## Features

- IEEE 802.11b/g Compliant
- Redundant 24 VDC power inputs or Power-over-Ethernet
- Powerful security with WPA/802.1X/MAC address filtering
- DIN-Rail mounting ability
- Case design meets IP 30 protection standard

## First-Time Installation and Configuration

Before installing the AWK-1100, check to make sure that all items in the Package Checklist are in the box. In addition, you will need access to a notebook computer or PC equipped with an Ethernet port. The AWK-1100 has a default IP address that you must use when connecting to the AWK-1100 for the first time.

---

**NOTE** For testing requirements, if you only have one AWK-1100, we strongly suggest that you prepare a notebook computer or PC with a wireless LAN adapter installed. After finishing the installation and configuration, you should test the AWK-1100 to make sure the wireless transmission is working normally.

---

### Step 1: Select the Power Source

The AWK-1100 can be powered by a DC power input, or by PoE (Power over Ethernet). The AWK-1100 will use the power source that you choose.

### Step 2: Connect the AWK-1100 to a notebook or PC

Since the AWK-1100 supports MDI/MDI-X auto-sensing, you can use either a straight-through cable or cross-over cable to connect the AWK-1100 to the notebook, if the LAN LED on the AWK-1100's front panel lights up, it means the connection is established.

### Step 3: Set up the computer's IP address

In a Windows environment, the computer's IP address can be changed in the TCP/IP settings window. Select an IP address on the same subnet as the AWK-1100. Since the AWK-1100's default IP address is 192.168.127.253, and the subnet mask is 255.255.255.0, you should set the IP address of the computer to 192.168.127.xxx.

### Step 4: Use the web-based manager to configure the AWK-1100

Open your computer's web browser and then type **http://192.168.127.253** in the address box to access the homepage of the web-based Network Manager. Before the homepage opens, you will need to enter the user name and password as shown in the following figure. For first-time configuration, enter the default user name and password and then click on **OK**:

#### Default user name & password

User name: **admin**

Password: **root**

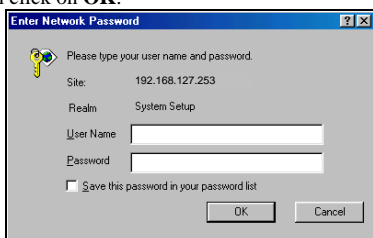

---

**NOTE** For security reasons, we strongly recommend changing the password. To do so, open the Network Manager homepage, click on **General** → **Password**, and then follow the onscreen instructions.

---

### Step 5: Select the operation mode for the AWK-1100

By default, the AWK-1100's operation mode is set to **Access Point**. If you want to change the setting, click on **General** → **Operation Mode**, as shown in the following figure, select an operation mode, and then click on **Save** to activate the change.

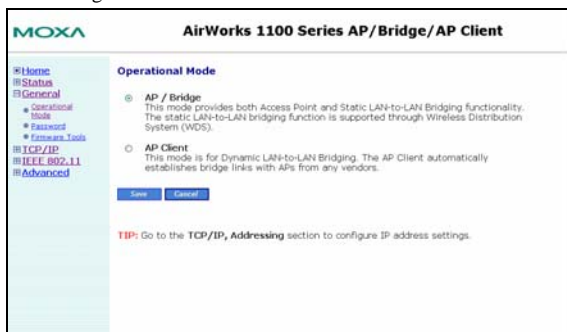

## Step 6: Test communications

We describe two test methods. Use the first method if you are using only one AWK-1100, and use the second method if you are using two or more AWK-1100s.

### Testing Method for one AWK-1100

If you are only using one AWK-1100, you will need a second notebook computer equipped with a WLAN card. Configure the WLAN card for connecting to the AWK-1100 (the default SSID is Moxa), and change the IP address of notebook B so that it is on the same subnet as notebook A.

After connecting the WLAN card, connect to the AWK-1100 and open a DOS window on notebook B. At the prompt, type

**ping** *IP address of notebook A*

and then press **Enter** (see the figure below). A “Reply from IP address ...” response means the communication was successful. A “Request timed out.” response means the communication failed. In this case, recheck the configuration to make sure the connections are correct.

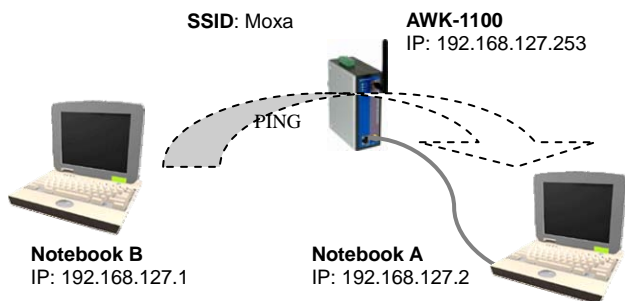

### Testing Method for two or more AWK-1100s

If you have two or more AWK-1100s, you will need a second notebook computer equipped with an Ethernet port. Use the default settings for the first AWK-1100, and change the second or third AWK-1100 to AP Client mode. Use the network settings shown in the following figure to configure the notebook and the AWK-1100.

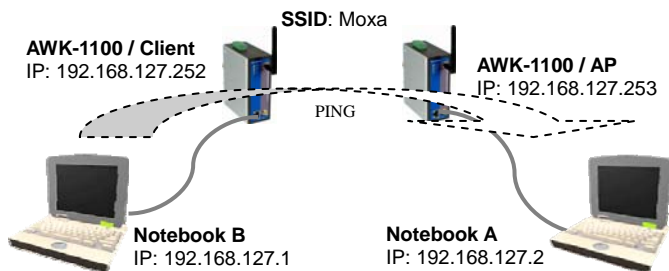

After setting up the testing environment, open a DOS window on notebook B. At the prompt, type

**ping** *IP address of notebook A*

and then press **Enter**. A “Reply from IP address ...” response means the communication was successful. A “Request timed out.” response means the communications failed. In this case, recheck the configuration to make sure the connections are correct.

**NOTE** Use the Link Monitor feature on the AP Client side to help confirm the wireless link quality and signal strength.

Linking Quality :	10 %
Signal Strength :	25 %

## Panel Layout of the AWK-1100

### Top Panel View

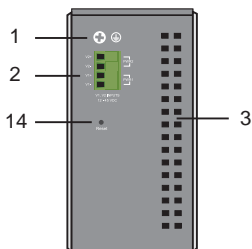

1. Grounding screw
2. Terminal block for power inputs PWR1 and PWR2
3. Heat dissipation orifices
4. Power input PWR1 LED
5. Power input PWR2 LED
6. Wireless LAN LED
7. Ethernet LAN LED

### Front Panel View

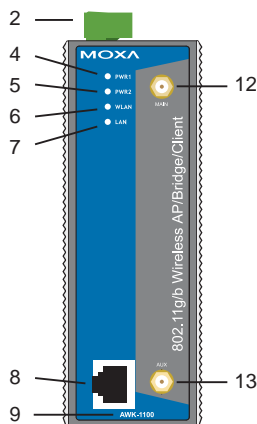

8. 10/100BaseT(X) RJ45 Port
9. Model Name
10. Screw hole for wall mounting kit
11. DIN-Rail mounting kit
12. MAIN antenna port
13. AUX antenna port
14. Reset button

### Rear Panel View

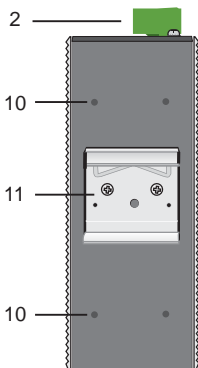

# Mounting Dimensions (unit=mm)

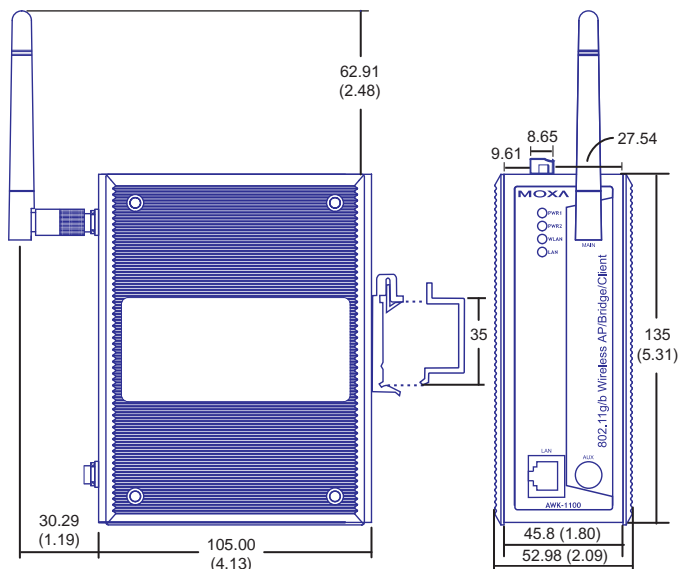

Side View

DIN-Rail Kit

Front View

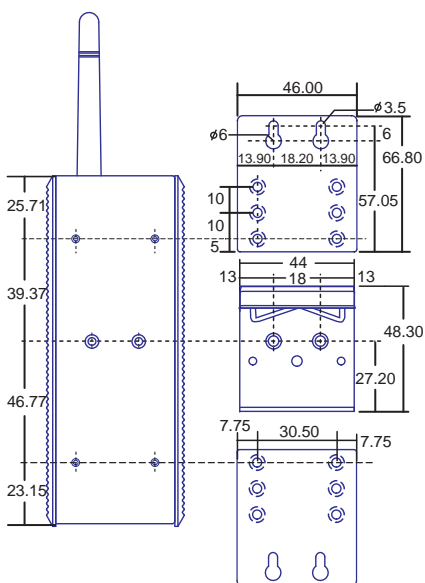

Rear View

Panel Mounting Kit

# DIN-Rail Mounting

The aluminum DIN-Rail attachment plate should be fixed to the back panel of the AWK-1100 when you take it out of the box. If you need to reattach the DIN-Rail attachment plate to the AWK-1100, make sure the stiff metal spring is situated towards the top, as shown in the figures below.

## STEP 1:

Insert the top of the DIN-Rail into the slot just below the stiff metal spring.

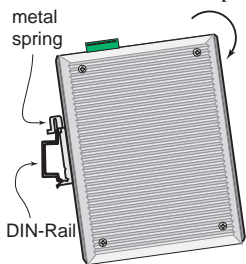

## STEP 2:

The DIN-Rail attachment unit will snap into place as shown below.

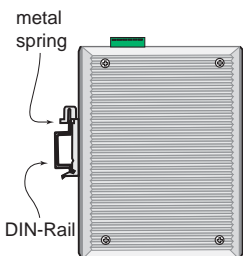

To remove the AWK-1100 from the DIN-Rail, simply reverse Steps 1 and 2 above.

# Wall Mounting (Optional)

For some applications, you will find it convenient to mount the AWK-1100 on the wall, as illustrated below.

## STEP 1:

Remove the aluminum DIN-Rail attachment plate from the AWK-1100, and then attach the wall mount plates with M3 screws, as shown in the diagrams below.

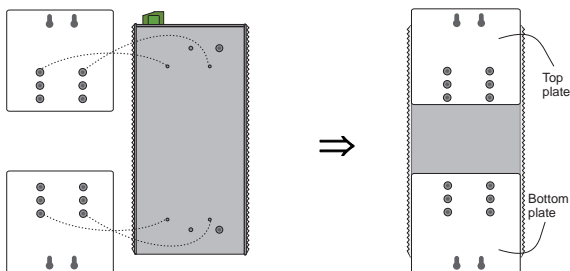

## STEP 2:

Mounting the AWK-1100 on the wall requires 4 screws. Use the AWK-1100, with wall mount plates attached, as a guide to mark the correct locations of the 4 screws. The heads of the screws should be less than 6.0 mm in diameter, and the shafts should be less than 3.5 mm in diameter, as shown in the figure at the right.

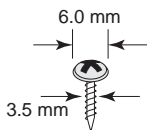

Do not screw the screws in all the way—leave a space of about 2 mm to allow room for sliding the wall mount panel between the wall and the screws.

---

**NOTE** Test the screw head and shank size by inserting the screw into one of the keyhole shaped apertures of the Wall Mounting Plates, before it is screwed into the wall.

---

### STEP 3:

Once the screws are fixed in the wall, insert the four screw heads through the large parts of the keyhole-shaped apertures, and then slide the AWK-1100 downwards, as indicated below. Tighten the four screws for added stability.

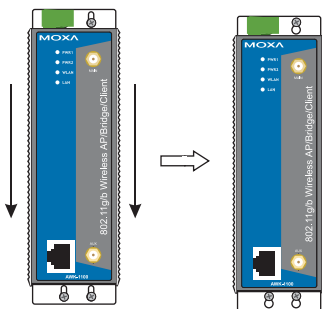

## Wiring Requirements

---

### ATTENTION



### Safety First!

Be sure to disconnect the power cord before installing and/or wiring your Moxa AWK-1100.

---

### ATTENTION



### Safety First!

Calculate the maximum possible current in each power wire and common wire. Observe all electrical codes dictating the maximum current allowable for each wire size.

If the current goes above the maximum ratings, the wiring could overheat, causing serious damage to your equipment.

---

You should also pay attention to the following points:

- Use separate paths to route wiring for power and devices. If power wiring and device wiring paths must cross, make sure the wires are perpendicular at the intersection point.

**NOTE:** Do not run signal or communications wiring and power wiring in the same wire conduit. To avoid interference, wires with different signal characteristics should be routed separately.

- You can use the type of signal transmitted through a wire to determine which wires should be kept separate. The rule of thumb is that wiring that shares similar electrical characteristics can be bundled together.
- Keep input wiring and output wiring separated.
- It is strongly advised that you label wiring to all devices in the system when necessary.





II 3G

## ATEX Information

1. Certificate number DEMKO 08 ATEX 0712961X
2. Ambient range ( $0^{\circ}\text{C} \leq T_{\text{amb}} \leq 60^{\circ}\text{C}$ )
3. Certification string (Ex nC nL IIC T4)
4. Standards covered ( EN60079-0:2006, EN60079-15:2005)
5. The conditions of safe usage:
  - These products must be mounted in an IP54 enclosure.
  - Install in an area of pollution degree 2 or less.
  - Use a conductor wire of size  $0.2 \text{ mm}^2$  or greater.
  - PROVISIONS SHALL BE MADE, EITHER IN EXTERNAL TO THE APPARATUS, TO PREVENT THE RATED VOLTAGE BEING EXCEEDED BY THE TRANSIENTS DISTURBANCES OF MORE THAN 40 %



## Grounding the Moxa AWK-1100

Grounding and wire routing help limit the effects of noise due to electromagnetic interference (EMI). Run the ground connection from the ground screw to the grounding surface prior to connecting devices.

ATTENTION

This product is intended to be mounted to a well-grounded mounting surface such as a metal panel.



## Wiring the Redundant Power Inputs

The top two contacts and the bottom two contacts of the 4-contact terminal block connector on the AWK-1100's top panel are used for the AWK-1100's two DC inputs. Top and front views of one of the terminal block connectors are shown here.

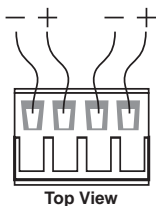

Top View

**STEP 1:** Insert the negative/positive DC wires into the V-/V+ terminals.

**STEP 2:** To keep the DC wires from pulling loose, use a small flat-blade screwdriver to tighten the wire-clamp screws on the front of the terminal block connector.

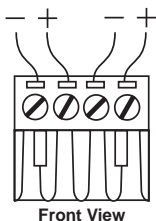

Front View

**STEP 3:** Insert the plastic terminal block connector prongs into the terminal block receptor, which is located on the AWK-1100's top panel.

**ATTENTION** Before connecting the AWK-1100 to the DC power inputs, make sure the DC power source voltage is stable.



## 10/100BaseT(X) Ethernet Port Connection

The 10/100BaseT(X) ports located on the AWK-1100's front panel are used to connect to Ethernet-enabled devices.

Below we show pinouts for both MDI (NIC-type) ports and MDI-X (HUB/Switch-type) ports, and also show cable wiring diagrams for straight-through and cross-over Ethernet cables.

### RJ45 (8-pin, MDI) Port Pinouts

Pin	Signal
1	Tx+
2	Tx-
3	Rx+
6	Rx-

### RJ45 (8-pin, MDI-X) Port Pinouts

Pin	Signal
1	Rx+
2	Rx-
3	Tx+
6	Tx-

### RJ45 (8-pin) to RJ45 (8-pin) Straight-Through Cable Wiring

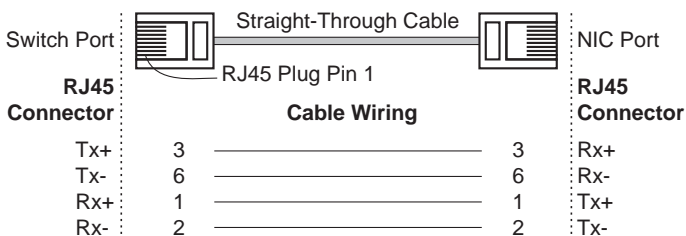

### RJ45 (8-pin) to RJ45 (8-pin) Cross-Over Cable Wiring

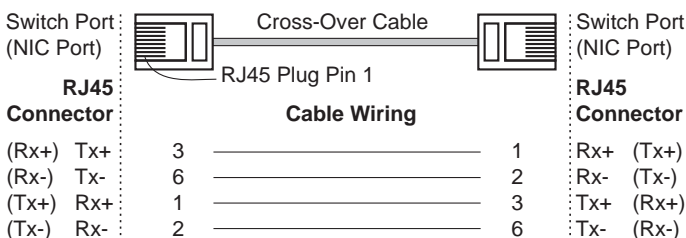

# LED Indicators

The front panel of the AWK-1100 contains several LED indicators. The function of each LED is described in the table below.

LED	Color	State	Description
PWR1	AMBER	On	Power is being supplied to power input PWR1
		Off	Power is <b>not</b> being supplied to power input PWR1
PWR2	AMBER	On	Power is being supplied to power input PWR2
		Off	Power is <b>not</b> being supplied to power input PWR2
WLAN	GREEN	On	RF port is active
		Blinking	Data is being transmitted via the RF port
		Off	RF port is <b>inactive</b>
LAN	GREEN	On	LAN port is active
		Blinking	Data is being transmitted/received via the LAN port
		Off	LAN port is <b>inactive</b>

## Auto MDI/MDI-X Connection

The Auto MDI/MDI-X function allows users to connect the AWK-1100's 10/100BaseTX ports to any kind of Ethernet device, without paying attention to the type of Ethernet cable being used for the connection. This means that you can use either a *straight-through* cable or *cross-over* cable to connect the AWK-1100 to Ethernet devices.

## Auto-Negotiation and Speed Sensing

The AWK-1100's RJ45 Ethernet port supports auto-negotiation for transmission speeds in the 10BaseT and 100BaseTX modes, with operation according to the IEEE 802.3u standard. Auto-negotiation takes place when an RJ45 cable connection is made, and then each time a LINK is enabled. The AWK-1100 advertises its capability for using either 10 Mbps or 100 Mbps transmission speeds, with the device at the other end of the cable expected to advertise similarly. Depending on what type of device is connected, this will result in agreement to operate at a speed of either 10 Mbps or 100 Mbps.

If an AWK-1100's RJ45 Ethernet port is connected to a non-negotiating device, it will default to 10 Mbps speed and half-duplex mode, as required by the IEEE 802.3u standard.

# Specifications

## WLAN

Standards	IEEE802.11g/b for wireless LAN, IEEE802.3u 10/100BaseTX for Ethernet LAN, IEEE802.3af for Power over Ethernet
Frequency Range	2.4-2.4835 GHz, Direct Sequence Spread Spectrum (DSSS)
Data Rate & Modulation	OFDM@54Mbps, CCK@11/5.5Mbps, DQPSK@2Mbps and DBSK@1Mbps
Operating Channels	USA: 1-11 (US) / Europe: 1-13 (EU) / Japan: 1-14 (JP)
Security	64-bit and 128-bit WEP encryption, WPA (IEEE 802.1X/RADIUS and TKIP)
Data Rates	1, 2, 5.5, 6, 9, 11, 12, 18, 24, 36, 48, 54 Mbps
Transmit Power	<u>802.11b:</u> ≥17dBm <u>802.11g:</u> 6/9Mbps≥17dBm, 12/18Mbps≥15dBm, 24Mbps≥14dBm, 36Mbps≥14dBm, 48Mbps≥12dBm, 54Mbps≥12dBm
Receiver Sensitivity	<u>802.11b:</u> 8% FER@1Mbps≤-91dBm, 8% FER@2Mbps≤-88dBm, 8% FER@5.5Mbps≤-85dBm, 8% FER@11Mbps≤-83dBm <u>802.11g:</u> 10% PER@6Mbps≤-88dBm, 10% PER@9Mbps≤-87dBm 10% PER@12Mbps≤-84dBm, 10% PER@18Mbps≤-82dBm 10% PER@24Mbps≤-79dBm, 10% PER@36Mbps≤-75dBm 10% PER@48Mbps≤-69dBm, 10% PER@54Mbps≤-68dBm

## Software Features

Protocols	HTTP, DHCP, TCP/IP, RADIUS, DNS, NetBIOS, NetBEUI, AppleTalk, and IPX/SPX
Configuration	Web-based management
Client OS Support	Windows 95/98/2000/ME/NT/XP, Unix and Macintosh

## Interface

Antenna	2dBi diversity antenna with an RP-SMA connector
RJ45 port	10/100BaseT(X) auto negotiation speed
LED Indicators	PWR1, PWR2, WLAN (Link/ACT), LAN (Link/ACT)

## Power

Input Voltage	12 to 45 VDC; Redundant dual DC power inputs or Power over Ethernet (PoE, power on RJ45 pins 4, 5 for power + and pins 7, 8 for power -)
Input Current (@24V)	0.3A
Connection	Removable Terminal Block
Overload Current Protection	1.6A
Reverse Polarity Protection	Present

## Mechanical

Casing	IP30 protection, aluminum case
Installation	DIN-Rail or wall mounting

## Environmental

Operating Temperature	0 to 60°C (32 to 140°F)
Storage Temperature	-20 to 70°C (-4 to 158°F)
Ambient Relative Humidity	5 to 95% (non-condensing)

## Regulatory Approvals

Safety	UL
Emissions	FCC, CE, SRRC

## Hazardous Location

Certificate	UL Class1, Div 2, Group A, B, C and D ATEX Class I, Zone 2, Ex nC nL IIc T4
-------------	--

**WARRANTY** 5 years

## Technical Support Contact Information

[www.moxa.com/support](http://www.moxa.com/support)

### Moxa Americas:

Toll-free: 1-888-669-2872  
Tel: +1-714-528-6777  
Fax: +1-714-528-6778

### Moxa China (Shanghai office):

Toll-free: 800-820-5036  
Tel: +86-21-5258-9955  
Fax: +86-10-6872-3958

### Moxa Europe:

Tel: +49-89-3 70 03 99-0  
Fax: +49-89-3 70 03 99-99

### Moxa Asia-Pacific:

Tel: +886-2-8919-1230  
Fax: +886-2-8919-1231