

AWK-1200 Series

IEEE 802.11g/b wireless Access Point/Bridge or AP Client for outdoors



AWK-1200-AP



AWK-1200-AC

- > IP68-rated wireless Access Point/Bridge and IP67-rated wireless AP Client
- > Point-to-point, point-to-multipoint wireless connectivity
- > WEP/WPA/WPA2/IEEE 802.1X authenticator supported
- > -20 to 70°C operating temperature range



The certification logos shown here apply to some or all of the products in this section. Please see the **Specifications** section or Moxa's website for details.

Introduction

The AWK-1200 Access Point/Bridge or AP Client is ideal for applications that are hard to wire, too expensive to wire, or use mobile equipment that connects to a TCP/IP network. The AWK-1200 series is rated to operate at temperatures ranging from -20 to 70°C, and its weatherproof design allows you to set up a WLAN, or extend existing wired networks to outdoor locations. In addition, the AWK-1200 has a detachable antenna design, which gives you the flexibility of choosing your own special-purpose antennas instead of using the standard models. You also don't need to worry about finding a power supply in outdoor environments, since the AWK-1200's PoE (Power over Ethernet) design makes it easy to deploy.

Advanced Security Capability

- 64-bit and 128-bit WEP (Wired Equivalent Privacy)
- Enable/disable SSID broadcasts
- MAC-address-based access control
- IEEE 802.1X/RADIUS
- WPA/WPA2

Useful Utilities and Remote Configuration

- Firmware upgrade from HTTP
- Web-based Management
- Supports SNMP
- Configuration backup and reset to factory default

Specifications

WLAN

Standards:

IEEE 802.11g/b for Wireless LAN
IEEE 802.3u for 10/100BaseT(X)

Frequency Range:

2.4-2.4835 GHz, Direct Sequence Spread Spectrum (DSSS)

Data Rate & Modulation:

OFDM @ 54 Mbps, CCK @ 11/5.5 Mbps, DQPSK @ 2 Mbps, and DBSK @ 1 Mbps

Operating Channels:

USA: 1-11 (US)
Europe: 1-13 (EU)
Japan: 1-14 (JP)

Security:

For AWK-1200-AP:
WEP, WPA, WPA2, IEEE 802.1X, MAC address filtering, Hide SSID, Layer 2 Isolation
For AWK-1200-AC:
64-bit and 128-bit WEP encryption, WPA

Data Rates:

1 Mbps, 2 Mbps, 5.5 Mbps, 6 Mbps, 9 Mbps, 11 Mbps, 12 Mbps, 18 Mbps, 24 Mbps, 36 Mbps, 48 Mbps, 54 Mbps

Transmit Power:

Typ. 17 dBm @ 1, 2, 5.5 and 11 Mbps, 17 dBm @ 6 Mbps, 14 dBm @ 54 Mbps

RX Sensitivity:

802.11b:
-81 dBm @ 11 Mbps
802.11g:
-65 dBm @ 54 Mbps, -66 dBm @ 48 Mbps,
-70 dBm @ 36 Mbps, -74 dBm @ 24 Mbps,
-77 dBm @ 18 Mbps, -79 dBm @ 12 Mbps,
-81 dBm @ 9 Mbps, -82 dBm @ 6 Mbps

Software

Protocols: HTTP, DHCP, TCP/IP, RADIUS, DNS, NetBIOS, AppleTalk, and IPX/SPX

Configuration: Web-based management

Client OS Support: Windows (95, 98, 2000, ME, NT, XP), Unix, Macintosh

Interface

Antenna:

AWK-1200-AP: 5 dBi External / N-type female connector
AWK-1200-AC: 9 dBi Internal

RJ45 Port: 10/100BaseT(X) auto negotiation speed

Power Requirements

Input Voltage: Active Ethernet, 48 VDC

Input Current (@ 48 VDC, PoE):

AWK-1200-AP: 0.38A

AWK-1200-AC: 0.375A

Physical Characteristics

Housing:

AWK-1200-AP: provides IP68 protection

AWK-1200-AC: provides IP67 protection

Dimensions:

AWK-1200-AP: 284.4 x 254.3 x 77.5 mm (11.20 x 10.01 x 3.05 in)

AWK-1200-AC: 165.8 x 195.8 x 60.3 mm (6.53 x 7.71 x 2.37 in)

Weight:

AWK-1200-AP: 3100 g

AWK-1200-AC: 600 g

Installation: Wall or Mast Mounting

Environmental Limits

Operating Temperature: -20 to 70°C (-4 to 158°F)

Storage Temperature: -40 to 80°C (-40 to 176°F)

Ambient Relative Humidity: 5% to 95% (non-condensing)

Regulatory Approvals

Safety: EN60950-1: 2001, UL60950-1

Radio: EN300 328

EMC: EN301 489-1/-17

EMI: FCC Part 15C

*Please check Moxa's website for the most up-to-date certification status.

Reliability

MTBF:

More than 200,000 hrs

Database: GB, GC (Ground Benign, Controlled) 25°C

Warranty

Warranty Period: 5 years

Details: See www.moxa.com/warranty

Dimensions

AWK-1200-AP

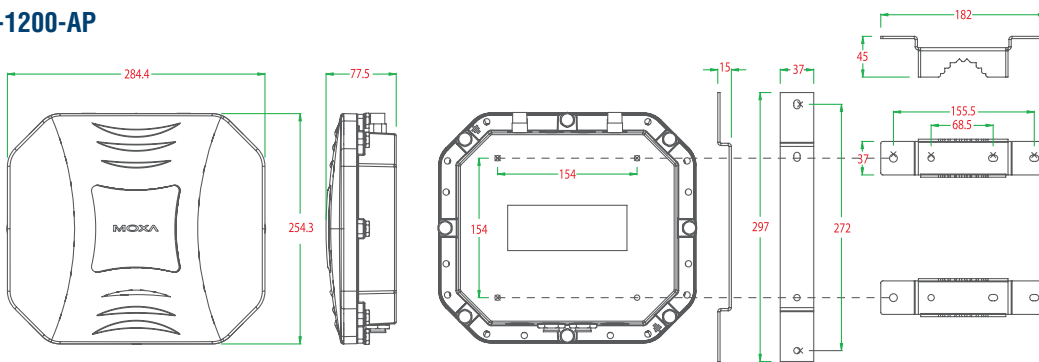

AWK-1200-AC

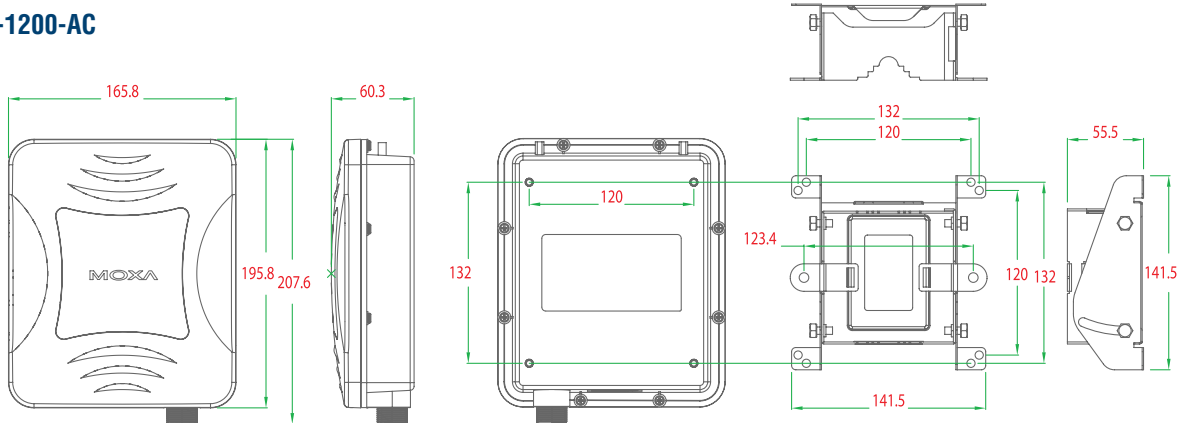

: Ordering Information

Available Models

AWK-1200-AP-US: IEEE 802.11g/b IP68 wireless AP/Bridge, US band, -20 to 70°C

AWK-1200-AP-EU: IEEE 802.11g/b IP68 wireless AP/Bridge, Euro band, -20 to 70°C

AWK-1200-AP-JP: IEEE 802.11 g/b IP68 wireless AP/Bridge, Japan band, -20 to 70°C

AWK-1200-AC-US: IEEE 802.11g/b IP67 wireless AP Client, US band, -20 to 70°C

AWK-1200-AC-EU: IEEE 802.11g/b IP67 wireless AP Client, Euro band, -20 to 70°C

AWK-1200-AC-JP: IEEE 802.11 g/b IP67 wireless AP Client, Japan band, -20 to 70°C