

# NPort 5600-8-DT/DTL Series User's Manual

---

Fifth Edition, February 2011

[www.moxa.com/product](http://www.moxa.com/product)



© 2011 Moxa Inc. All rights reserved.  
Reproduction without permission is prohibited.

# NPort 5600-8-DT/DTL Series User's Manual

The software described in this manual is furnished under a license agreement and may be used only in accordance with the terms of that agreement.

## Copyright Notice

Copyright ©2011 Moxa Inc.  
All rights reserved.  
Reproduction without permission is prohibited.

## Trademarks

The MOXA logo is a registered trademark of Moxa Inc.  
All other trademarks or registered marks in this manual belong to their respective manufacturers.

## Disclaimer

Information in this document is subject to change without notice and does not represent a commitment on the part of Moxa.

Moxa provides this document as is, without warranty of any kind, either expressed or implied, including, but not limited to, its particular purpose. Moxa reserves the right to make improvements and/or changes to this manual, or to the products and/or the programs described in this manual, at any time.

Information provided in this manual is intended to be accurate and reliable. However, Moxa assumes no responsibility for its use, or for any infringements on the rights of third parties that may result from its use.

This product might include unintentional technical or typographical errors. Changes are periodically made to the information herein to correct such errors, and these changes are incorporated into new editions of the publication.

## Technical Support Contact Information

[www.moxa.com/support](http://www.moxa.com/support)

### **Moxa Americas**

Toll-free: 1-888-669-2872  
Tel: +1-714-528-6777  
Fax: +1-714-528-6778

### **Moxa Europe**

Tel: +49-89-3 70 03 99-0  
Fax: +49-89-3 70 03 99-99

### **Moxa China (Shanghai office)**

Toll-free: 800-820-5036  
Tel: +86-21-5258-9955  
Fax: +86-21-5258-5505

### **Moxa Asia-Pacific**

Tel: +886-2-8919-1230  
Fax: +886-2-8919-1231

# Table of Contents

<b>1. Introduction</b>	<b>1-1</b>
Overview	1-2
Product Features	1-2
Package Checklist	1-2
<b>2. Overview of Hardware</b>	<b>2-1</b>
Panel Layout (DT and DT-J models)	2-2
Top and Rear Views	2-2
Front Views	2-2
Bottom View	2-3
Panel Layout (DTL and DTL-T models)	2-4
Top and Rear Views	2-4
Front View	2-4
Bottom View	2-5
LED Indicators	2-5
Top Panel Indicators	2-5
Ethernet Port Indicators	2-6
Pin Assignments	2-6
Ethernet Port Pinouts	2-6
Device Port Pinouts	2-6
Console Port Pinouts (applies only to DT models)	2-7
Product Specifications	2-7
NPort 5600-8-DT	2-7
NPort 5600-8-DTL	2-9
<b>3. Basic Installation</b>	<b>3-1</b>
Before You Begin	3-2
Required Items	3-2
Wiring Guidelines	3-2
STEP 1: Connect network, serial device, and power	3-3
Connect to Network	3-3
Attach Serial Device	3-3
Connect Power	3-4
STEP 2: Configure the device server's general settings	3-4
Install NPort Administrator	3-4
Search for Device Server on LAN	3-4
Adjust General Settings	3-5
Verify Network Settings	3-6
STEP 3: Configure device port operation mode	3-6
Adjust Operation Mode Settings	3-6
STEP 4: Configure serial communication parameters	3-8
Review Serial Parameters	3-8
Adjust Serial Parameters	3-8
STEP 5: Map COM port to device	3-9
Specify Target Device Server	3-10
Assign COM Port Number to Device Port	3-10
Apply Change	3-11
<b>4. General Settings</b>	<b>4-1</b>
Overview	4-2
Basic Settings	4-2
Network Settings	4-3
Serial Settings	4-5
Operating Settings	4-6
Accessible IP Settings	4-6
Auto Warning Settings	4-7
Email and SNMP trap	4-7
Event Type	4-8
Change Password	4-9
<b>5. Introduction to Operation Modes</b>	<b>5-1</b>
Overview	5-2
Real COM Mode	5-2
RFC2217 Mode	5-3
TCP Server Mode	5-3
TCP Client Mode	5-3
UDP Mode	5-4
Pair Connection Modes	5-4
Reverse Telnet Mode	5-4
Disabled Mode	5-4

<b>6. Operation Mode Advanced Settings</b> .....	<b>6-1</b>
Overview .....	6-2
List of Parameters .....	6-2
When to Make Adjustments .....	6-2
Using Pair Connection Modes.....	6-3
Parameter Details .....	6-3
Connection Management Parameters .....	6-3
Data Packing Parameters .....	6-4
Other Parameters.....	6-6
<b>7. Using the Web Console</b> .....	<b>7-1</b>
Overview .....	7-2
Web Browser Settings .....	7-2
Basic Navigation.....	7-3
Device Server Settings .....	7-4
Special Functions.....	7-4
Monitor .....	7-4
Load Factory Defaults .....	7-5
<b>8. Using NPort Administrator</b> .....	<b>8-1</b>
Overview .....	8-2
Installing NPort Administrator .....	8-2
Basic Navigation .....	8-5
Window Layout .....	8-5
Activating a Function .....	8-5
Configuration .....	8-6
Finding Your Device Server.....	8-6
Status.....	8-7
Device Server Parameters .....	8-8
Firmware and Configuration Management.....	8-10
Monitor.....	8-11
Finding Your Device Server.....	8-11
Monitoring Parameters .....	8-12
Activating the Monitor.....	8-13
Port Monitor .....	8-15
COM Mapping.....	8-15
Finding Your Device Server.....	8-16
COM Mapping Settings .....	8-17
Saving COM Mapping Settings.....	8-19
COM Grouping.....	8-20
Creating a COM Group .....	8-20
Deleting a COM Group.....	8-22
Adding a Port to a COM Group .....	8-23
Removing a Port from a COM Group .....	8-24
Modifying Ports in a COM Group .....	8-25
IP Address Report.....	8-28
Automatic Message Log .....	8-29
<b>9. NPort CE Driver Manager for Windows CE</b> .....	<b>9-1</b>
Overview .....	9-2
Installing NPort CE Driver Manager .....	9-2
Using NPort CE Driver Manager .....	9-2
<b>10. Other Configuration Interfaces</b> .....	<b>10-1</b>
Overview .....	10-2
LCM Console (applies to DT models only).....	10-2
Main Menu → Server setting .....	10-2
Main Menu → Network setting.....	10-2
Main Menu → Serial set .....	10-2
Main Menu → Op Mode set .....	10-3
Main Menu → Console .....	10-3
Main Menu → LCM passwd prot .....	10-3
Main Menu → Reset btn prot .....	10-3
Main Menu → Ping .....	10-3
Main Menu → Save/Restart .....	10-3
Telnet Console .....	10-3
Serial Console (NPort 5600-8-DT).....	10-3
Serial Console (NPort 5600-8-DTL).....	10-4
<b>11. TTY Drivers for Linux and UNIX</b> .....	<b>11-1</b>
Linux Real TTY Drivers .....	11-2
Basic Steps.....	11-2
Installing Linux Real TTY Driver Files .....	11-2
Mapping TTY Ports.....	11-2

Removing Mapped TTY Ports.....	11-3
Removing Linux Driver Files.....	11-3
UNIX Fixed TTY Drivers .....	11-4
Installing the UNIX Driver.....	11-4
Configuring the UNIX Driver .....	11-4
<b>12. The IP Serial Library .....</b>	<b>12-1</b>
Overview .....	12-2
IP Serial Library Function Groups.....	12-2
Example Program .....	12-3
<b>13. Troubleshooting .....</b>	<b>13-1</b>
Connection Problems.....	13-1
Operation Mode Problems .....	13-1
Real COM Mode.....	13-1
TCP Server Mode.....	13-2
TCP Client Mode.....	13-2
UDP Mode .....	13-2
Serial Data Problems.....	13-3
<b>A. Cable Wiring.....</b>	<b>A-1</b>
RS-232 Cables .....	A-2
RS-422, 4-wire RS-485 Cables .....	A-2
2-wire RS-485 Cables.....	A-2
<b>B. SNMP Agent with MIB II &amp; RS-232-Like Group .....</b>	<b>B-1</b>
<b>C. IP Report Protocol.....</b>	<b>C-1</b>
IP Address Report Structure.....	C-1
Hardware and AP ID.....	C-2
Example .....	C-2
<b>D. Compliance Notice.....</b>	<b>D-1</b>

# Introduction

---

The Moxa NPort 5600-8-DT/DTL, a line of advanced serial device servers, makes it easy to enable your serial devices for network operation. The NPort 5600-8-DT/DTL includes the following eleven models:

## **RS-232 models**

- NPort 5610-8-DT
- NPort 5610-8-DT-J
- NPort 5610-8-DTL
- NPort 5610-8-DTL-T

## **RS-232/422/485 models**

- NPort 5650-8-DT
- NPort 5650-8-DT-J
- NPort 5650I-8-DT
- NPort 5650-8-DTL
- NPort 5650-8-DTL-T
- NPort 5650I-8-DTL
- NPort 5650I-8-DTL-T

The following topics are covered in this chapter:

- Overview**
- Product Features**
- Package Checklist**

# Overview

Your NPort 5600-8-DT/DTL device server provides instant Ethernet network access to industrial devices through a serial connection. Devices such as PLCs, meters, and sensors can use the device server to connect to an IP-based Ethernet LAN, making the devices accessible from anywhere over a local LAN or the Internet. The device server's space-saving design makes it ideal for many applications:

- Central monitoring and control of card readers, alarms, and electronic gate security systems in campus dormitories
- Dial-up access to private company servers
- Management of server farm devices (routers, hubs, switches) through serial console ports
- Network access to medical diagnostic equipment

The device server provides different operation modes, such as TCP Server mode or UDP mode, to ensure compatibility with software using standard network APIs (Winsock or BSD Sockets). Real COM and Real TTY drivers are included to allow easy, transparent operation using virtual COM/TTY ports over a TCP/IP network. The drivers help preserve your software investment by providing instant network access with minimum disruption to existing systems.

Configuration can be done manually or using automatic IP protocols (DHCP or BOOTP) through the web console. NPort Administrator, a Windows utility, is provided for straightforward installation as well as storage and retrieval of all system parameters.

## Product Features

The device server includes the following features:

- Compact desktop size
- Eight ports supporting RS-232, RS-422, or RS-485 operation
- Socket operation modes including TCP Server mode, TCP Client mode, and UDP mode
- 10/100 Mbps Ethernet port(s) with auto-speed detection
- Multiple device ports with independent selection of serial interface
- Built-in 15 KV ESD protection for all serial signals
- Supports SNMP MIB-II for network management
- Changeable voice alarm for exceptions (this feature is only available for HW Rev. 1.2 and earlier of the NPort 5600-8-DT)

## Package Checklist

- NPort 5600-8-DT or NPort 5600-8-DTL device server
- Wall mounting and Din-Rail kits
- Stick-on pads
- Documentation and software CD
- Quick installation guide (printed)
- Warranty card

### Optional Accessories

- DK-35A: DIN-rail mounting kit (35 mm)
- CBL-RJ45M9-150: 8-pin RJ45 to male DB9 cable, 150 cm
- CBL-RJ45F9-150: 8-pin RJ45 to female DB9 cable, 150 cm
- CBL-RJ45M25-150: 8-pin RJ45 to male DB25 cable, 150 cm
- CBL-RJ45F25-150: 8-pin RJ45 to female DB25 cable, 150 cm
- NP21101: Male DB25 to female DB9 RS-232 cable, 30 cm

*Note: Optional Accessories can be ordered separately.*

**NOTE** Please notify your sales representative if any of the above items are missing or damaged



## Overview of Hardware

---

NPort 5600-8-DT/DTL device servers are rugged and easy-to-use device networking products. Use this chapter to familiarize yourself with the hardware and specifications.

The following topics are covered in this chapter:

▣ **Panel Layout (DT and DT-J models)**

- Top and Rear Views
- Front Views
- Bottom View

▣ **Panel Layout (DTL and DTL-T models)**

- Top and Rear Views
- Front View
- Bottom View

▣ **LED Indicators**

- Top Panel Indicators
- Ethernet Port Indicators

▣ **Pin Assignments**

- Ethernet Port Pinouts
- Device Port Pinouts
- Console Port Pinouts (applies only to DT models)

▣ **Product Specifications**

- NPort 5600-8-DT
- NPort 5600-8-DTL

# Panel Layout (DT and DT-J models)

**NOTE** The figures in this section apply to the following DT and DT-J models:

- NPort 5610-8-DT
- NPort 5610-8-DT-J
- NPort 5650-8-DT
- NPort 5650-8-DT-J
- NPort 5650I-8-DT

## Top and Rear Views

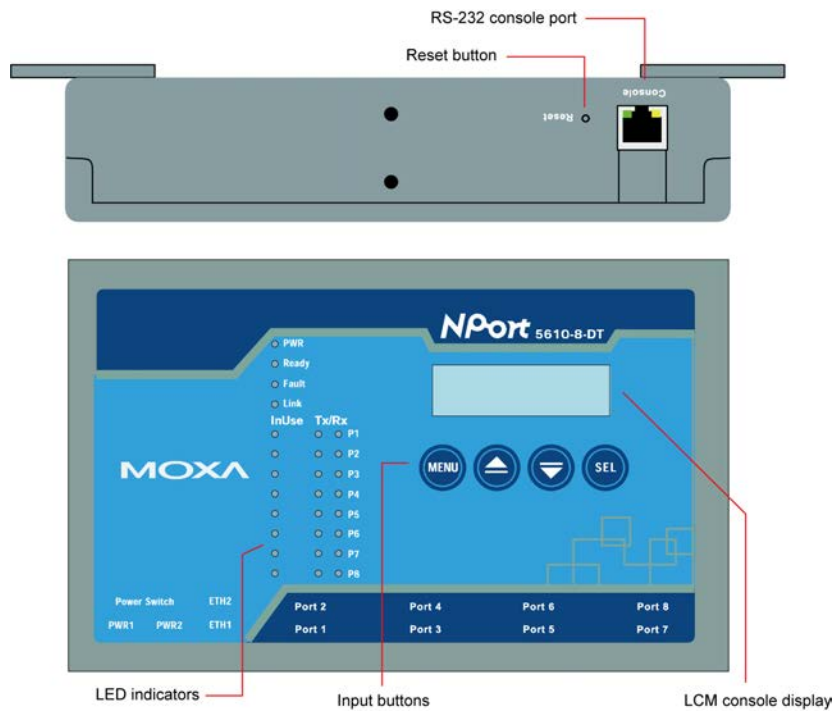

## Front Views

### NPort 5610-8-DT, 5650-8-DT, 5650I-8-DT

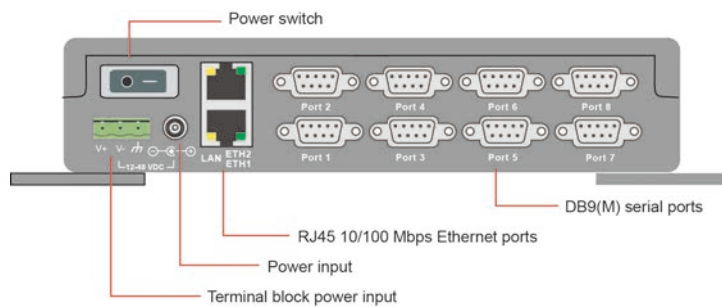

**NPort 5610-8-DT-J, 5650-8-DT-J**

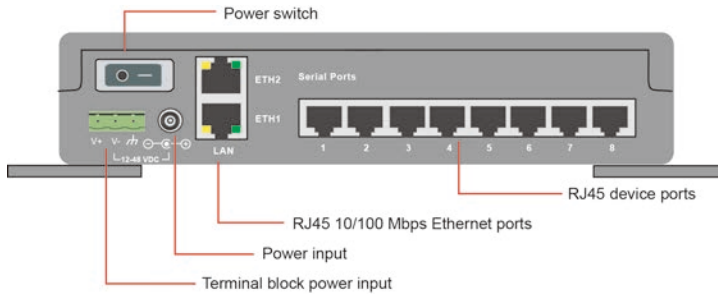

**Bottom View**

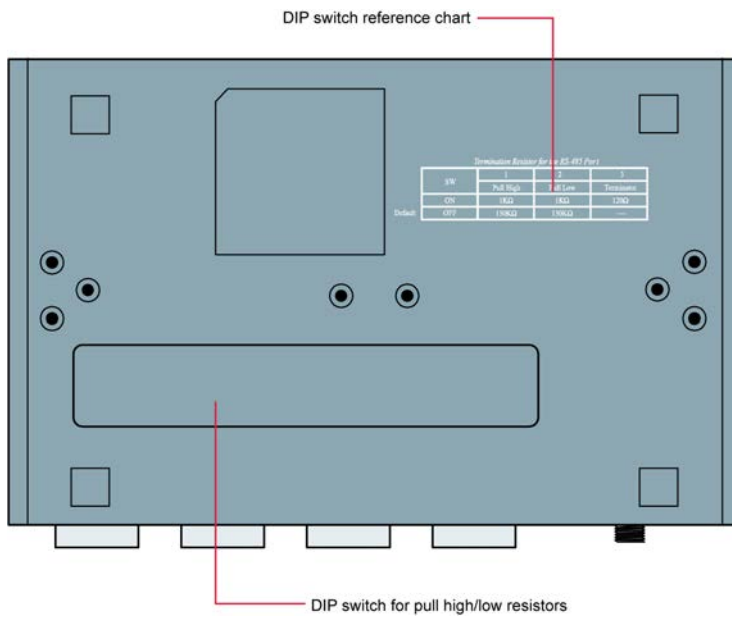

Item	Description
PWR LED	Indicates power input status (red)
Ready and Fault LEDs	Indicates normal operation (green) or IP conflict (red)
Link LED	Flashes when Ethernet is connected
InUse LEDs	Flashes when device port is transmitting or receiving data (green)
Device port Tx LEDs	Flashes when device port is transmitting data (green)
Device port Rx LEDs	Flashes when device port is receiving data (orange)
Power input	For power jack connection to AC power source here
Ethernet port	For Ethernet network cable connection
DB9(M) serial ports	For attachment of serial devices
Reset button	Press and hold with a pointed object for 5 seconds to load factory defaults

# Panel Layout (DTL and DTL-T models)

**NOTE** The figures in this section apply to the following DTL and DTL-T models:

- NPort 5610-8-DTL
- NPort 5650-8-DTL
- NPort 5650I-8-DTL
- NPort 5610-8-DTL-T
- NPort 5650-8-DTL-T
- NPort 5650I-8-DTL-T

## Top and Rear Views

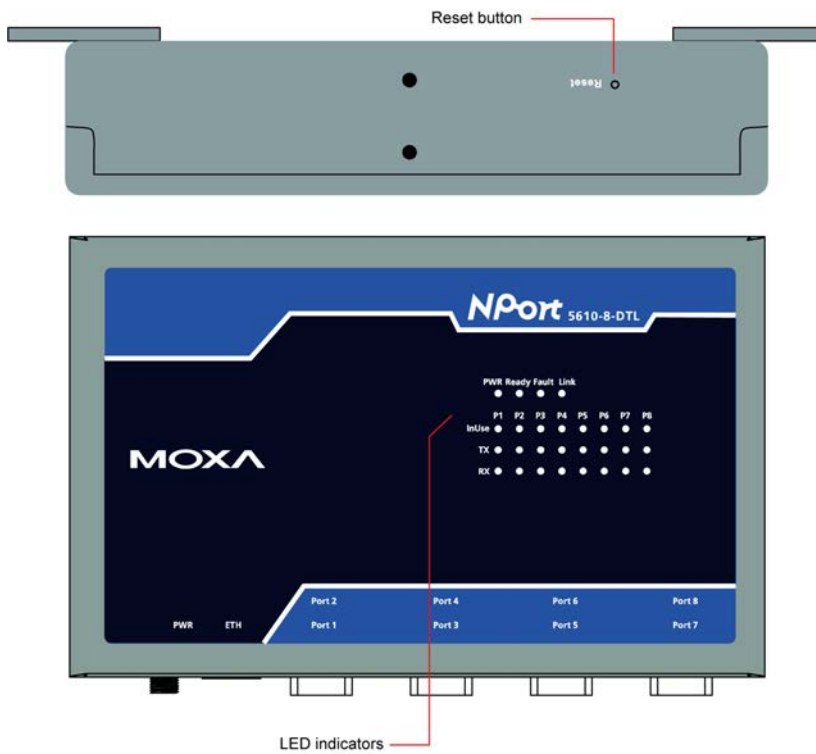

## Front View

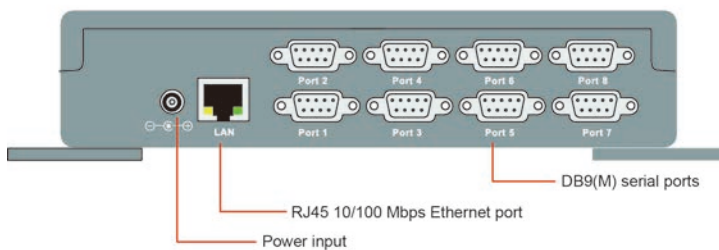

## Bottom View

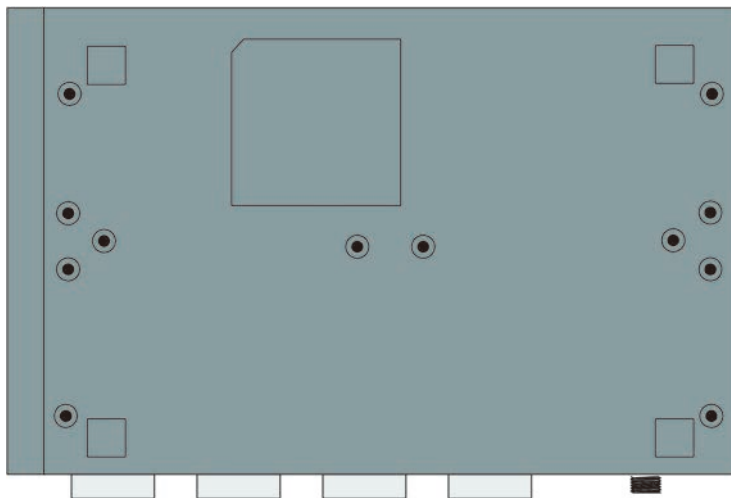

Item	Description
PWR LED	Indicates power input status (red)
Ready and Fault LEDs	Indicates normal operation (green) or IP conflict (red)
Link LED	Flashes when Ethernet is connected
InUse LEDs	Flashes when device port is transmitting or receiving data (green)
Device port Tx LEDs	Flashes when device port is transmitting data (green)
Device port Rx LEDs	Flashes when device port is receiving data (orange)
Power input	For power jack connection to AC power source here
Ethernet port	For Ethernet network cable connection
DB9(M) serial ports	For attachment of serial devices
Reset button	Press and hold with a pointed object for 5 seconds to load factory defaults

## LED Indicators

### Top Panel Indicators

Name	Color	Function
PWR	red	Power is on.
	off	Power is off.
Ready	green	Steady: The NPort is operational. Blinking: The NPort is responding to NPort Administrator's "Locate" function or the NPort is resetting to the factory default.
	off	Power is off or fault condition exists.
Fault	red	IP conflict or DHCP or BOOTP server did not respond properly.
	off	No fault condition detected.
Link	green	Steady: Network is connected, no data is being transmitted. Blinking: Network is connected, data is being transmitted.
	off	Ethernet cable is disconnected or has a short.
InUse (P1 to P8)	green	Serial port has been opened by server side software.
	off	Serial port is not currently opened by server side software.
Tx/Rx (P1 to P8)	green (Tx)	Serial device is transmitting data.
	orange (Rx)	Serial device is receiving data.
	off	No data is flowing to or from the serial port.

## Ethernet Port Indicators

Two LED indicators are built into each 10/100M Ethernet connector. A valid network connection will be indicated as follows:



A green LED indicates a valid connection to a 100 Mbps Ethernet network.



An orange LED indicates a valid connection to a 10 Mbps Ethernet network.

## Pin Assignments

### Ethernet Port Pinouts

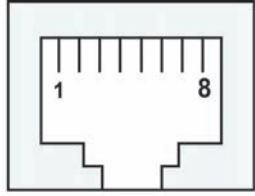
RJ45 Connector	Pin	Signal
	1	RXD+
	2	RXD-
	3	TXD+
	4	–
	5	–
	6	TXD-
	7	–
	8	–

### Device Port Pinouts

**DB9 Ports** (NPort 5610-8-DT, 5650-8-DT, 5650I-8-DT, 5610-8-DTL/DTL-T, 5650-8-DTL/DTL-T, and 5650I-8-DTL/DTL-T)

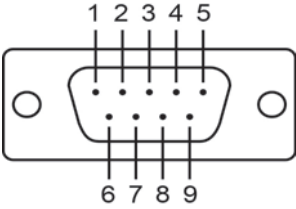
DB9 Male Connector	Pin	RS-232	RS-422/RS-485-4w	RS-485-2w
	1	DCD	TxD-(A)	–
	2	RxD	TxD+(B)	–
	3	TxD	RxD+(B)	Data+(B)
	4	DTR	RxD-(A)	Data-(A)
	5	GND	GND	GND
	6	DSR	–	–
	7	RTS	–	–
	8	CTS	–	–
	9	–	–	–

The NPort 5610-8-DT and 5610-8-DTL only support RS-232 signals.

**RJ45 Ports** (NPort 5610-8-DT-J, 5650-8-DT-J)

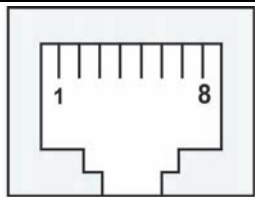
RJ45 Connector	Pin	RS-232	RS-422/RS-485-4w	RS-485-2w
	1	DSR	–	–
	2	RTS	TxD+	–
	3	GND	GND	GND
	4	TxD	TxD-	–
	5	RxD	RxD+	Data+
	6	DCD	RxD-	Data-
	7	CTS	–	–

	8	DTR	-	-
--	---	-----	---	---

The NPort 5610-8-DT-J only supports RS-232 signals.

## Console Port Pinouts (applies only to DT models)

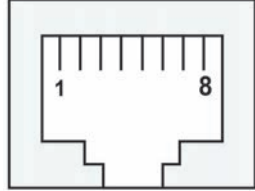
RJ45 Connector	Pin	RS-232
	1	DSR
	2	RTS
	3	GND
	4	TxD
	5	RxD
	6	DCD
	7	CTS
	8	DTR

## Product Specifications

### NPort 5600-8-DT

#### Ethernet Interface

**Number of Ports:** 2 (1 IP)

**Speed:** 10/100 Mbps, auto MDI/MDIX

**Connector:** 8-pin RJ45

**Magnetic Isolation Protection:** 1.5 KV built-in

#### Serial Interface

**Number of Ports:** 8

**Serial Standards:**

NPort 5610-8-DT: RS-232

NPort 5650-8-DT: RS-232/422/485

**Connector:**

NPort 5610-8-DT/5650-8-DT/5650I-8-DT: DB9 male

NPort 5610-8-DT-J/5650-8-DT-J: RJ45 (8 pins)

**Serial Line Protection:**

15 KV ESD protection for all signals

2 KV isolation protection (NPort 5650I-8-DT only)

**RS-485 Data Direction Control:** ADDC® (automatic data direction control)

**Pull High/Low Resistor for RS-485:** 1 KΩ, 150 KΩ

**Terminator for RS-485:** 120 Ω

#### Serial Communication Parameters

**Data Bits:** 5, 6, 7, 8

**Stop Bits:** 1, 1.5, 2

**Parity:** None, Even, Odd, Space, Mark

**Flow Control:** DSR/DTR and RTS/CTS (RS-232 only), XON/XOFF

**Baudrate:** 50 bps to 921.6 Kbps

#### Serial Signals

**RS-232:** TxD, RxD, RTS, CTS, DTR, DSR, DCD, GND

**RS-422:** Tx+, Tx-, Rx+, Rx-, GND

**RS-485-4w:** Tx+, Tx-, Rx+, Rx-, GND

**RS-485-2w:** Data+, Data-, GND

#### Software

**Network Protocols:** ICMP, IP, TCP, UDP, DHCP, BOOTP, Telnet, DNS, SNMP V1, HTTP, SMTP, SNTP, Rtelnet, ARP, RFC2217

**Configuration Options:** Web Console, Telnet Console, Serial Console, Windows Utility

**Windows Real COM Drivers:** Windows 95/98/ME/NT/2000, Windows XP/2003/Vista/2008/7 x86/x64, Embedded CE 5.0/6.0, XP Embedded

**Fixed TTY Drivers:** SCO Unix, SCO OpenServer, UnixWare 7, UnixWare 2.1, SVR 4.2, QNX 4.25, QNX 6, Solaris 10, FreeBSD, AIX 5.x, HP-UX 11i

**Linux Real TTY Drivers:** Linux kernel 2.4.x, 2.6.x

### Mini Screen with Push Buttons

**LCD Panel:** Liquid Crystal Display on the case

**Push Buttons:** Four push buttons for convenient on-site configuration

### Physical Characteristics

**Housing:** Metal, IP30 protection

#### Weight:

NPort 5610-8-DT: 1760 g

NPort 5610-8-DT-J: 1710 g

NPort 5650-8-DT: 1770 g

NPort 5650-8-DT-J: 1710 g

NPort 5650I-8-DT: 1850 g

#### Dimensions:

Without ears: 197 x 44 x 125 mm (7.76 x 1.73 x 4.92 in)

With ears: 229 x 46 x 125 mm (9.01 x 1.81 x 4.92 in)

With DIN-Rail kit on bottom panel: 197 x 53 x 125 mm (7.76 x 2.09 x 4.92 in)

### Environmental Limits

**Operating Temperature:** 0 to 55°C (32 to 131°F)

**Storage Temperature:** -20 to 70°C (-4 to 158°F)

**Ambient Relative Humidity:** 5 to 95% (non-condensing)

### Power Requirements

**Input Voltage:** 12 to 48 VDC

#### Power Consumption:

NPort 5610-8-DT:

611 mA @ 12 V, 300 mA @ 24 V, 140 mA @ 48 V

NPort 5610-8-DT-J:

611 mA @ 12 V, 300 mA @ 24 V, 140 mA @ 48 V

NPort 5650-8-DT:

615 mA @ 12 V, 300 mA @ 24 V, 156 mA @ 48 V

NPort 5650I-8-DT:

1066 mA @ 12 V, 510 mA @ 24 V, 200 mA @ 48 V

NPort 5650-8-DT-J:

615 mA @ 12 V, 300 mA @ 24 V, 156 mA @ 48 V

### Standards and Certifications

**Safety:** UL 60950-1, EN 60950-1

**EMC:** CE, FCC

**EMI:** EN 55022 Class A, FCC Part 15 Subpart B Class A

**EMS:** EN 55024

### Reliability

**Alert Tools:** Built-in buzzer and RTC (real-time clock)

**Automatic Reboot Trigger:** Built-in WDT (watchdog timer)

**MTBF (mean time between failures):** 163,356 hrs

### Warranty

**Warranty Period:** 5 years

**Details:** See [www.moxa.com/warranty](http://www.moxa.com/warranty)



## NPort 5600-8-DTL

### Ethernet Interface

**Number of Ports:** 1

**Speed:** 10/100 Mbps, auto MDI/MDIX

**Connector:** 8-pin RJ45

**Magnetic Isolation Protection:** 1.5 KV built-in

### Serial Interface

**Number of Ports:** 8

**Serial Standards:**

NPort 5610-8-DTL: RS-232

NPort 5650-8-DTL/5650I-8-DTL: RS-232/422/485

**Connector:** DB9 male

**Serial Line Protection:**

15 KV ESD protection for all signals

2 KV isolation protection (NPort 5650I-8-DTL only)

**RS-485 Data Direction Control:** ADDC® (automatic data direction control)

**Pull High/Low Resistor for RS-485:** 1 K $\Omega$ , 150 K $\Omega$

**Terminator for RS-485:** 120  $\Omega$

### Serial Communication Parameters

**Data Bits:** 5, 6, 7, 8

**Stop Bits:** 1, 1.5, 2

**Parity:** None, Even, Odd, Space, Mark

**Flow Control:** DSR/DTR and RTS/CTS (RS-232 only), XON/XOFF

**Baudrate:** 50 bps to 921.6 Kbps

### Serial Signals

**RS-232:** TxD, RxD, RTS, CTS, DTR, DSR, DCD, GND

**RS-422:** Tx+, Tx-, Rx+, Rx-, GND

**RS-485-4w:** Tx+, Tx-, Rx+, Rx-, GND

**RS-485-2w:** Data+, Data-, GND

### Software

**Network Protocols:** ICMP, IP, TCP, UDP, DHCP, BOOTP, Telnet, DNS, SNMP V1, HTTP, SMTP, SNTP, Rtelnet, ARP, RFC2217

**Configuration Options:** Web Console, Telnet Console, Serial Console, Windows Utility

**Windows Real COM Drivers:** Windows 95/98/ME/NT/2000, Windows XP/2003/Vista/2008/7 x86/x64, XP Embedded

**Fixed TTY Drivers:** SCO Unix, SCO OpenServer, UnixWare 7, UnixWare 2.1, SVR 4.2, QNX 4.25, QNX 6, Solaris 10, FreeBSD, AIX 5.x, HP-UX 11i

**Linux Real TTY Drivers:** Linux kernel 2.4.x, 2.6.x

### Physical Characteristics

**Housing:** Metal, IP30 protection

**Weight:**

NPort 5610-8-DTL: 1760 g

NPort 5650-8-DTL: 1770 g

NPort 5650I-8-DTL: 1850 g

**Dimensions:**

Without ears: 197 x 44 x 125 mm (7.76 x 1.73 x 4.92 in)

With ears: 229 x 46 x 125 mm (9.01 x 1.81 x 4.92 in)

With DIN-Rail kit on bottom panel: 197 x 53 x 125 mm (7.76 x 2.09 x 4.92 in)

### Environmental Limits

**Operating Temperature:**

Standard Models: 0 to 60°C (32 to 140°F)

Wide Temp. Models: -40 to 75°C (-40 to 167°F)

**Storage Temperature:** -40 to 85°C (-40 to 185°F)

**Ambient Relative Humidity:** 5 to 95% (non-condensing)

### Power Requirements

**Input Voltage:** 12 to 48 VDC

#### Power Consumption:

NPort 5610-8-DTL:

340 mA @ 12 V, 180 mA @ 24 V, 110 mA @ 48 V

NPort 5650-8-DTL:

470 mA @ 12 V, 250 mA @ 24 V, 140 mA @ 48 V

NPort 5650I-8-DTL:

740 mA @ 12 V, 370 mA @ 24 V, 220 mA @ 48 V

### Standards and Certifications

**Safety:** UL 60950-1, EN 60950-1

**EMC:** CE, FCC

**EMI:** EN 55022 Class A, FCC Part 15 Subpart B Class A

**EMS:** EN 55024

### Reliability

**Alert Tools:** Built-in buzzer and RTC (real-time clock)

**Automatic Reboot Trigger:** Built-in WDT (watchdog timer)

### Warranty

**Warranty Period:** 5 years

**Details:** See [www.moxa.com/warranty](http://www.moxa.com/warranty)

## Basic Installation

---

NPort 5600-8-DT/DTL device servers are designed to coordinate between your network, your host computer, and your serial device. Installation of the device server should occur in stages to ensure that each connection is recognized. This chapter will guide you through a typical installation with a Windows PC. For certain applications or environments, you may be guided to other chapters for additional information.

The following topics are covered in this chapter:

### ❑ Before You Begin

- Required Items
- Wiring Guidelines

### ❑ STEP 1: Connect network, serial device, and power

- Connect to Network
- Attach Serial Device
- Connect Power

### ❑ STEP 2: Configure the device server's general settings

- Install NPort Administrator
- Search for Device Server on LAN
- Adjust General Settings
- Verify Network Settings

### ❑ STEP 3: Configure device port operation mode

- Adjust Operation Mode Settings

### ❑ STEP 4: Configure serial communication parameters

- Review Serial Parameters
- Adjust Serial Parameters

### ❑ STEP 5: Map COM port to device

- Specify Target Device Server
- Assign COM Port Number to Device Port
- Apply Change

## Before You Begin

This chapter will walk you through the major steps of a typical installation and will offer advice on adjustments and options for specific applications. Please note that certain procedures will vary for your specific application and environment.

In these instructions, a Windows PC is used for configuration. For Linux or UNIX environments, please refer to Chapter 11.

Installation of the NPort 5600-8-DT/DTL is presented in the following steps:

- Step 1:** Connect power, network and serial devices
- Step 2:** Configure the device server's IP settings
- Step 3:** Configure each port's operation mode
- Step 4:** Configure each port's serial communication settings
- Step 5:** Map host COM ports to device ports (for Real COM mode)

## Required Items

Make sure that you have the following items before beginning your installation:

- NPort 5600-8-DT/DTL device server
- Windows PC with live connection to the network (see Chapter 11 for Linux/UNIX installations)
- NPort Documentation & Software CD
- Ethernet cable
- Serial cable for device attachment
- Power adapter and power cord
- Make sure that you have the following information available before beginning your installation:
  - IP address of your Windows PC
  - IP address and subnet to be assigned to the device server
  - TCP or UDP port number to be used for each device port
  - Local COM port number to be used for each device port (for Real COM mode)
  - Baudrate, parity, data bit, and stop bit settings for each device port

## Wiring Guidelines

The following guidelines will help ensure trouble-free signal communication with the device server.

- Use separate paths to route wiring for power and devices to avoid interference. Do not run signal or communication wiring and power wiring in the same wire conduit. The rule of thumb is that wiring that shares similar electrical characteristics can be bundled together.
- If power wiring and device wiring paths must cross, make sure the wires are perpendicular at the intersection point.
- Keep input wiring and output wiring separate.
- Label all wiring to each device in the system for easier testing and troubleshooting

**ATTENTION****Wiring Safety Precautions:****Disconnect power source**

Do not install or wire this unit or any attached devices with the power connected. Disconnect the power before installation by removing the power cord before installing and/or wiring your unit.

**Follow maximum current ratings**

Calculate the maximum possible current in each power wire and common wire. Observe all electrical codes dictating the maximum current allowable for each wire size.

If the current goes above the maximum ratings, the wiring could overheat, causing serious damage to your equipment.

**Use caution - unit may get hot**

The unit will generate heat during operation, and the casing may feel hot to the touch. Take care when handling unit. Be sure to leave adequate space for ventilation.

## STEP 1: Connect network, serial device, and power

This step covers the physical installation of the hardware. This step requires the following items:

- NPort 5600-8-DT/DTL device server
- Power adapter and power cord
- Ethernet cable
- Serial cable with RJ45 or DB9 connector (depending on model)
- Serial device

### Connect to Network

After placing the device server in its location, plug one end of the network cable into one of the device server's Ethernet ports. Plug the other end of the cable to the network. There are two Ethernet ports on the NPort 5600-8-DT/DTL so you can easily daisy-chain multiple units together (the NPort 5600-8-DTL has one Ethernet port only).

### Attach Serial Device

Use the serial cable to connect your serial device to a device port on the NPort 5600-8-DT/DTL. Make sure that you are familiar with your device's serial communication settings (e.g., baudrate, stop bit, etc.). You will need to know these parameters when configuring the device server and drivers.

**Adjustable Pull High/Low Resistors for RS-485**

Termination resistors may be needed when connecting RS-485 devices to your NPort, in order to prevent the reflection of serial signals. The device port's pull high/low resistors must then be set correctly to prevent signal corruption.

- **NPort 5600-8-DT:** Use the DIP switches on the bottom panel to configure each device port's pull high/low resistors. You will need to unscrew the DIP switch cover to access the DIP switches.

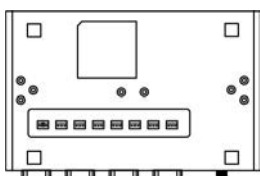

- **NPort 5600-8-DTL:** Remove the top cover to access the DIP switches used to configure each device port's pull high/low resistors (note that SW4 is reserved for future use).

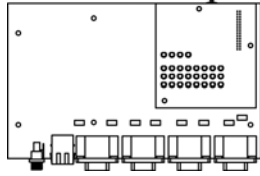

The pull high/low resistor values for each device port are set as follows:

	SW	1	2	3
		Pull High	Pull Low	Terminator
Default	ON	1 KΩ	1 KΩ	120 Ω
	OFF	150 KΩ	150 KΩ	

Do not use the 1 KΩ setting when using RS-232. Doing so will degrade the RS-232 signals and reduce the effective communication distance.



**ATTENTION**

Grounding and wire routing helps limit the effects of noise due to electromagnetic interference (EMI). Before attaching any serial devices, run your ground wire from your grounding surface to the device server's grounding contact at the rear panel. Secure the connection with the provided screw.

## Connect Power

Connect the 12 to 48 VDC power line to the NPort 5600-8-DT/DTL's terminal block or power jack. The "Ready" LED will initially glow red. When the system is ready, the "Ready" LED will turn green.

## STEP 2: Configure the device server's general settings

This step covers the configuration of general settings using NPort Administrator. You may also use the web, serial, Telnet, or LCM console to configure the device server. Please refer to Chapter 7, 8, and 10 for additional information on using the other consoles.

This step requires the following items:

- NPort 5600-8-DT/DTL device server with live connection to the network
- Windows PC with live connection to the same network (see Chapter 11 for Linux/UNIX installations)
- NPort Documentation & Software CD

## Install NPort Administrator

Locate and run the setup program on the NPort Document & Software CD. The setup program will be named **Npadm\_Setup\_[Version]\_Build\_[DateTime].exe** (e.g., "**Npadm\_Setup\_Ver1.8\_Build\_07041316.exe**"). Run NPort Administrator when installation is complete.

## Search for Device Server on LAN

In NPort Administrator, click "Search" to search your LAN for NPort device servers.

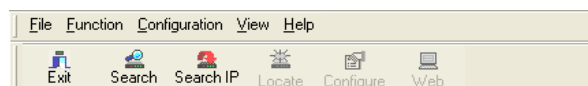

When your unit appears in the search results, you may click “Stop” to end the search. You may also wait a few more moments for the search to complete.

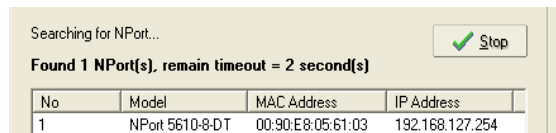

The “Configuration” panel will list the NPort device servers that were found on the LAN. If your unit cannot be found, you may have a network problem. Please check all cables and verify that your PC and device server are on the same LAN. If you still have problems, try connecting the device server directly to your PC.

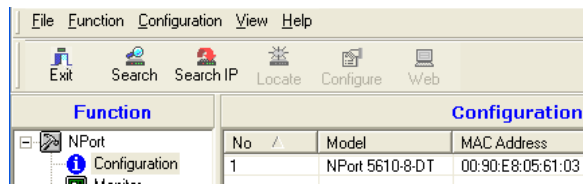

## Adjust General Settings

Right-click your unit in the “Configuration” panel and select “Configure” in the context menu. If your device server is password protected, first select “Unlock” in the context menu.

In the configuration window, go to the “Network” tab. For any parameter that you wish to change, click the appropriate “Modify” box and make the desired adjustments. The device server must be assigned a valid, unique IP address for operation in your network. Both fixed and dynamic IP addresses are supported. Please consult with your network administrator if you are not sure how to set these parameters.

When you are ready to restart the device server with the new settings, click “OK”.

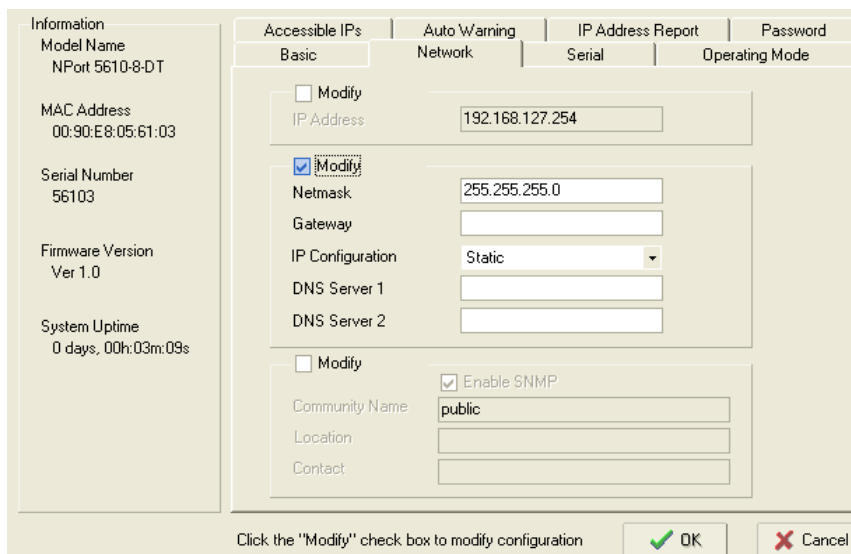

### Static IP Addresses

For most applications, you will assign a fixed IP address to the device server. To assign a static (fixed) IP address, the “IP Configuration” parameter must be set to “Static”, which is the default setting. You may then modify the “IP Address” and “Netmask” parameters.

### Dynamic IP Addresses

For certain network environments, your device server’s IP address will be assigned by a DHCP or BOOTP server. In this case, instead of assigning the device server’s IP address, you will need to configure the device server to receive its IP address from the appropriate server. Set the “IP Configuration” parameter to “DHCP”, “BOOTP”, or “DHCP/BOOTP”, depending on your network environment. The “IP Address” and “Netmask” parameters will be unavailable for editing since these parameters will be assigned automatically.

If you are not sure whether you need to configure your device server for a dynamic or static IP address, consult the administrator who set up the LAN.

## Verify Network Settings

If your device server has been configured correctly, you should be able to ping its IP address from your PC. First make sure that your PC and device server are on the same subnet, then ping the device server's address. If no response is received, you will need to check your cables and network settings.

## STEP 3: Configure device port operation mode

This step covers configuration of a device port's operation mode. The operation mode determines how the device port will interact with the network. The selection of operation mode will depend on your specific application. Please refer to the chart on the following page for guidance in selecting the operation mode. For additional information, please refer to Chapter 5.

This step requires the following items:

- NPort 5600-8-DT/DTL device server with live connection to the network
- Windows PC with live connection to the same network and NPort Administrator installed

Make sure that NPort Administrator is open with your device server listed in the configuration pane. You should also have an understanding of your intended device networking application and the appropriate settings.

## Adjust Operation Mode Settings

The operation mode parameters for each device port can be configured through NPort Administrator. Open your device server's configuration window using the same method when you adjusted the network parameters. On the "Operation Modes" tab, click "Modify" and select the device port that you wish to configure. Click "Settings" to configure the selected device port.

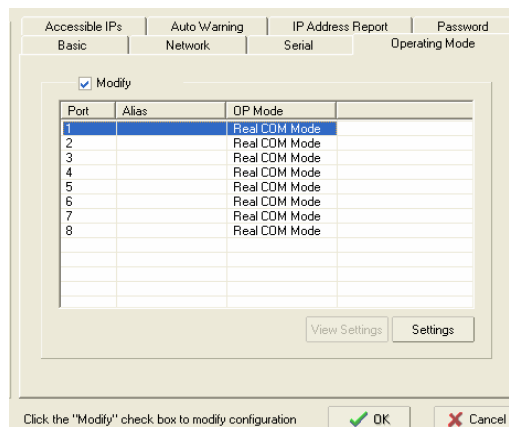

Set the operation mode and associated parameters as necessary. Please refer to Chapter 5 and 6 for additional information on operation modes and advanced settings. When you are ready to restart the device server with the new settings, click "OK".

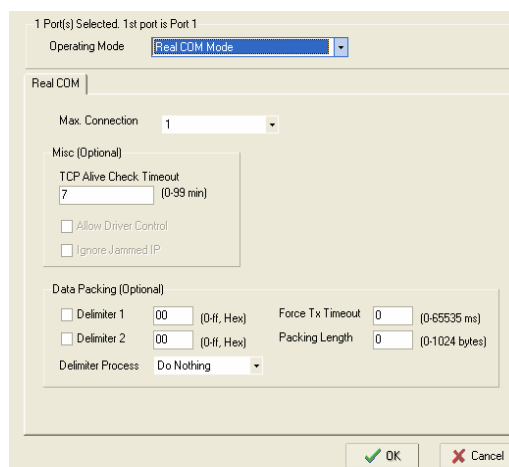



**Operation Mode Selection Chart**

You can use this chart to help you select the appropriate operation mode for your application.

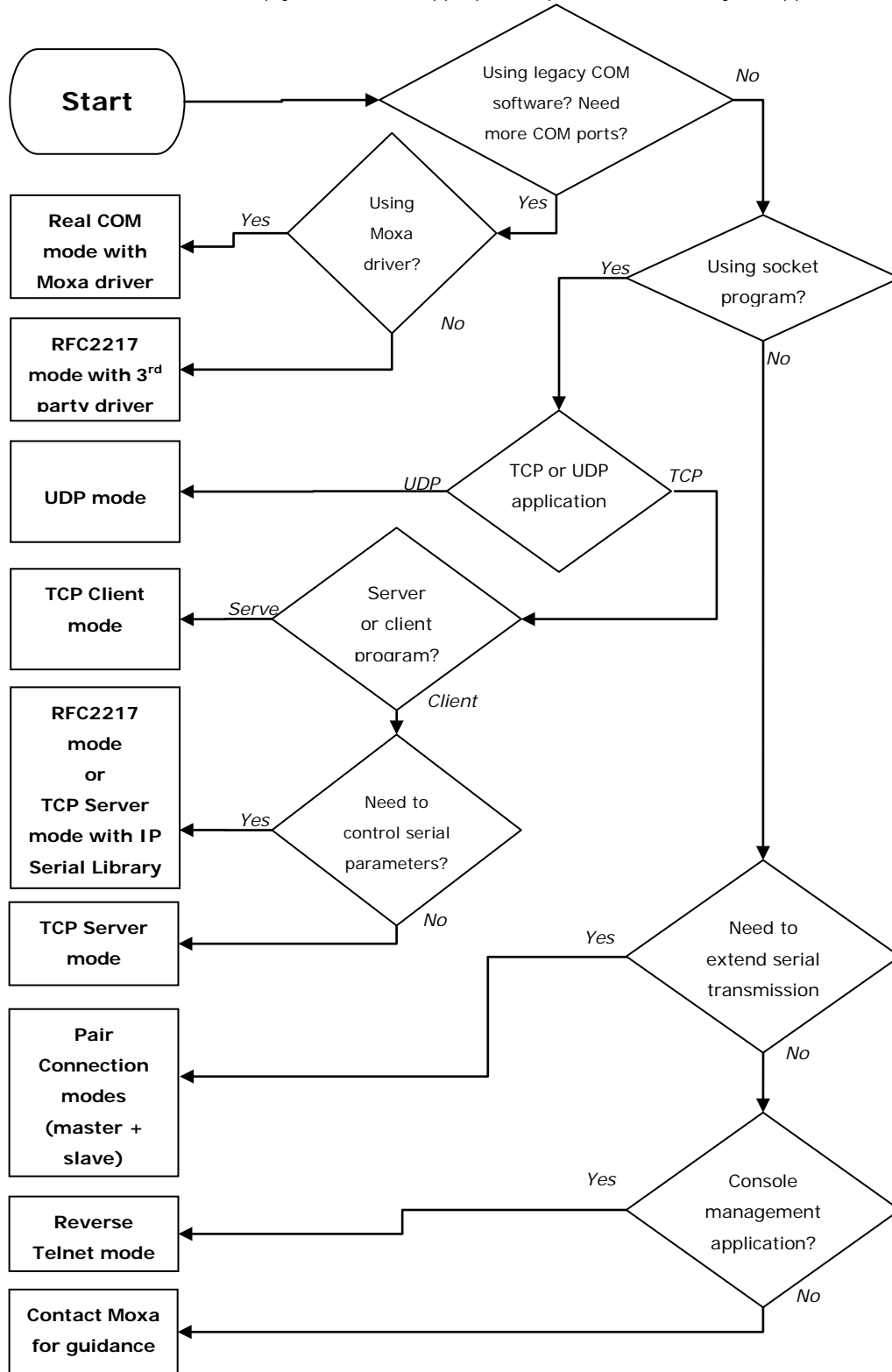

## STEP 4: Configure serial communication parameters

This step covers the configuration of each device port's serial communication parameters, such as baudrate, stop bit, etc.

This step requires the following items:

- NPort 5600-8-DT/DTL device server with live connection to the network
- Windows PC with live connection to the same network and NPort Administrator installed

Make sure that NPort Administrator is open with your device server listed in the configuration pane. You should also know the serial communication parameters for the attached device and intended application.

### Review Serial Parameters

The following parameters need to be set correctly on the device port for proper communication with your device. Please refer to your device's documentation for the appropriate settings.

Parameter	Options	Description
Baudrate	50 bps 115.2 Kbps (default) 921 Kbps	This is the rate of data transmission to and from the attached serial device.
Data bits	5 6 7 8 (default)	This is the size of each data character.
Stop bits	1 (default) 1.5 2	This is the size of the stop character.
Parity	None (default) Even Odd Space Mark	This is the kind of parity that will be used. Even and Odd parity provide rudimentary error-checking; Space and Mark parity are rarely used.
Flow control	None RTS/CTS (default) DTR/DSR Xon/Xoff	This is the method used to suspend and resume data transmission to ensure that data is not lost. RTS/CTS (hardware) flow control is recommended if possible.
FIFO	Enable (default) Disable	This controls whether the device port's built-in 128-byte FIFO buffer is used. When enabled, the FIFO helps reduce data loss regardless of direction.
Interface	RS-232 (default) RS-422 RS-485-2W RS-485-4W	This is the serial interface that will be used. The options that are available depend on the specific model of device server.

### Adjust Serial Parameters

The serial communication parameters for each device port can be configured through NPort Administrator. Open your device server's configuration window using the same method when you adjusted the network parameters. On the "Serial" tab, click "Modify" and select the device port that you wish to configure. Click "Settings" to configure the selected device port.

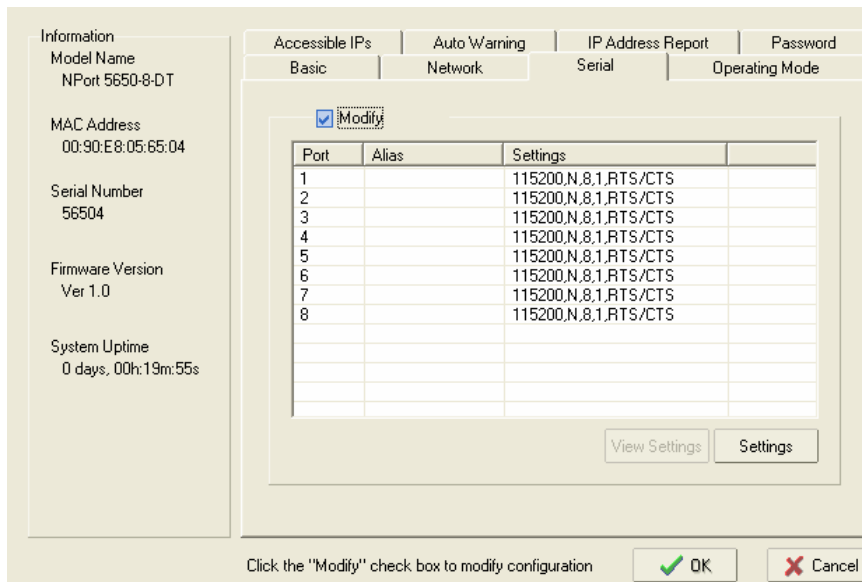

Make adjustments to the parameters as necessary. When you are ready to restart the device server with the new settings, click "OK".

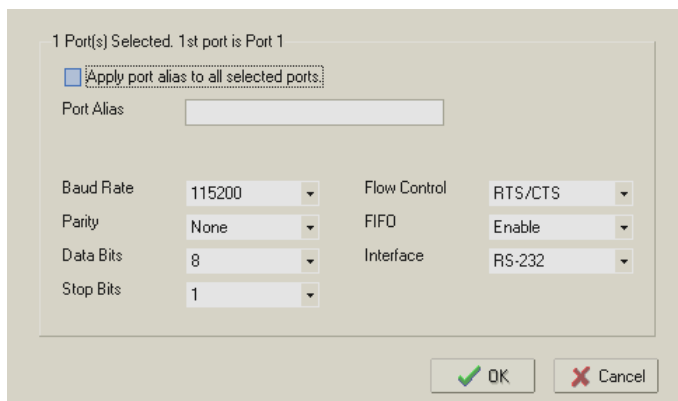

## STEP 5: Map COM port to device

This step covers the mapping of COM ports on a Windows PC to NPort device ports. This allows Windows software to access serial devices over the network as if they were local COM devices, for instant device networking without software migration. COM mapping is supported in Real COM and RFC2217 modes only.

The following instructions are for device ports operating in Real COM mode. For device ports operating in RFC2217 mode, follow the instructions for your particular driver. Real COM mode also supports TTY port mapping in Linux and UNIX systems.

This step requires the following items:

- NPort 5600-8-DT/DTL device server with the following:
  - Live connection to the network
  - Device port configured for Real COM operation
- Windows PC with the following:
  - Live connection to the same network
  - NPort Administrator installed
  - Software for intended serial application installed

Make sure that NPort Administrator is open with your device server listed in the configuration panel. You should also know the serial communication parameters for the attached device and intended application.

## Specify Target Device Server

In NPort Administrator, click “COM Mapping” in the Function panel to open the COM Mapping window. Right-click an empty line in the COM Mapping window and select “Add Target” in the context menu to assign your device server as the mapping target. A list of NPort device servers that have been found by NPort Administrator will appear. Select your device server and click “Finish”.

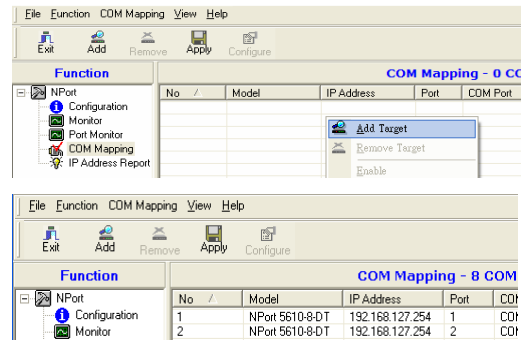

## Assign COM Port Number to Device Port

The COM Mapping window will show a list of available device ports on the network. Right-click the target device port and select “COM Settings” in the context menu.

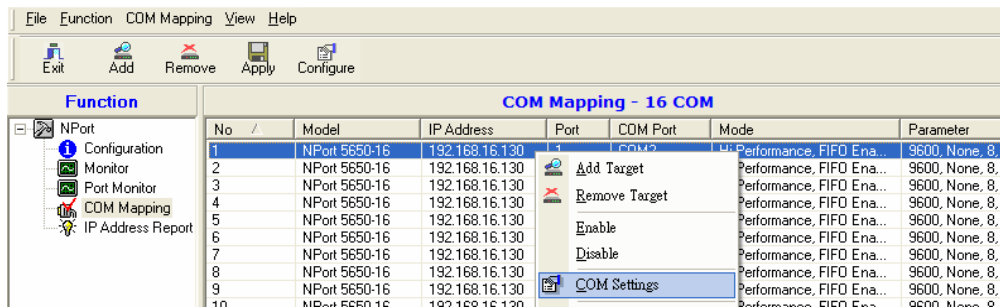

In the Basic Settings tab, select the COM port number that will be mapped to the device port. You can map multiple COM ports at the same time, in which case the “Auto Enumerating” feature may be used to automatically number the COM ports.

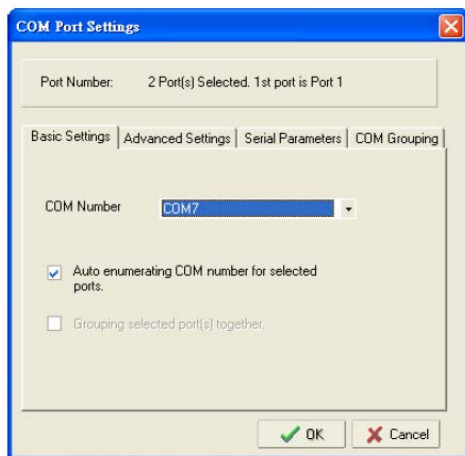

In the Serial Parameters tab, adjust the settings to match your device. These settings, used for serial printer only, must also match the settings on the device port. Click "OK" when you are satisfied with your changes.

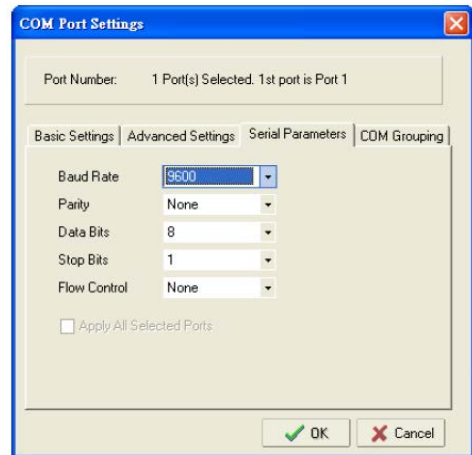

**Advanced Settings**

For additional details on Advanced Settings in NPort Administrator, please refer to Chapter 8.

**Tx Mode:** In Hi-Performance mode, the driver immediately issues a "Tx Empty" response to the program after sending data to the NPort. In Classical mode, the driver sends the "Tx Empty" response after confirmation is received from the NPort. Classical mode is recommended if you want to ensure that all data is sent out before further processing.

**FIFO:** This tells the driver whether or not to use the FIFO. **Network Timeout:** This specifies when an open, close, or serial parameter change operation will time out.

**Fast Flush:** When enabled, the driver flushes only the local buffer on the host for a Win32 PurgeComm() function call. When disabled, both the local and remote buffers are flushed. If your application uses PurgeComm() and performance seems sluggish, try enabling Fast Flush.

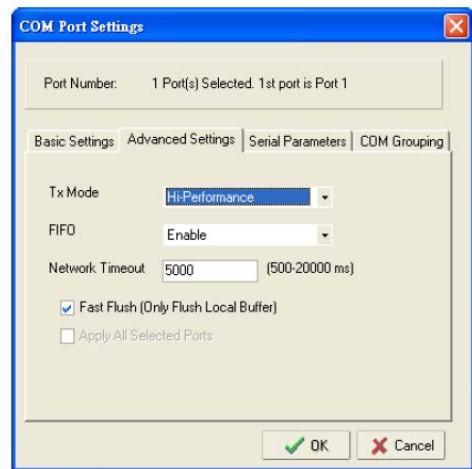

**Apply Change**

Right-click COM Mapping in the Function panel and select "Apply Change" in the context menu to save the current COM mapping settings. Your application will now be able to access the target serial device using the COM port.

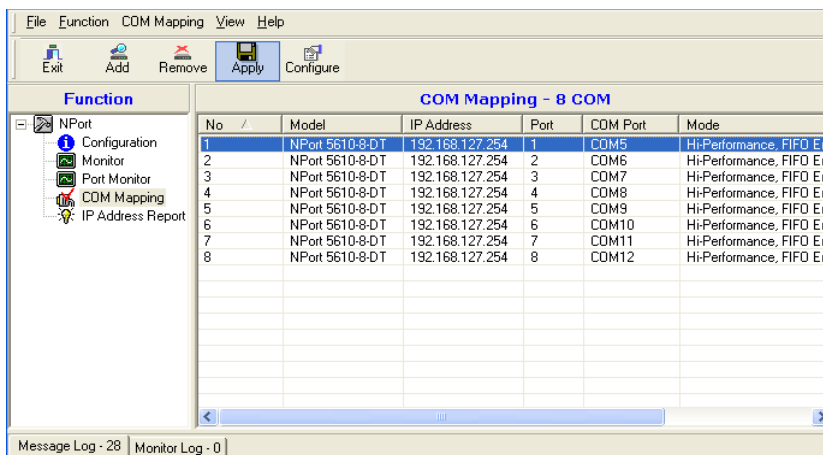

## General Settings

---

NPort 5600-8-DT/DTL device servers are easily configured to suit your network environment and your application. This chapter covers general settings for your device server.

The following topics are covered in this chapter:

- **Overview**
- **Basic Settings**
- **Network Settings**
- **Serial Settings**
- **Operating Settings**
- **Accessible IP Settings**
- **Auto Warning Settings**
  - Email and SNMP trap
  - Event Type
- **Change Password**

# Overview

The NPort 5600-8-DT/DTL can be configured through NPort Administrator, the web console, the Telnet console, or the serial console. For each of these configuration interfaces, parameters are organized by type. For this chapter, screenshots from the web console are used to illustrate the available parameters, but the same parameters can be modified using the other interfaces.

# Basic Settings

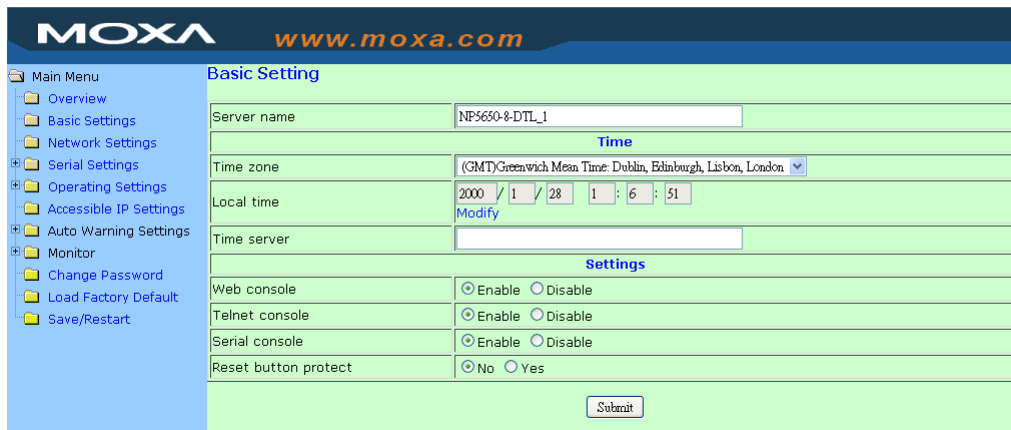

**Server name** (default = blank): This is an optional free text field for your own use. It does not affect operation of the NPort device server. It can be used to help differentiate one device server from another.



### ATTENTION

There is a risk of explosion if the real-time clock battery is replaced incorrectly! The real time clock is powered by a lithium battery. We strongly recommend that you obtain assistance from a Moxa support engineer before replacing the battery. Please contact the Moxa RMA service team if you need to change the battery.

**Time zone** (default = GMT Greenwich Mean Time): This field shows the currently selected time zone and allows you to select a different time zone.

**Local time:** This field shows the time that you last opened or refreshed the browser, using the NPort’s built-in real-time clock. You can adjust the real-time clock using this field. Make sure that you first select the correct time zone.

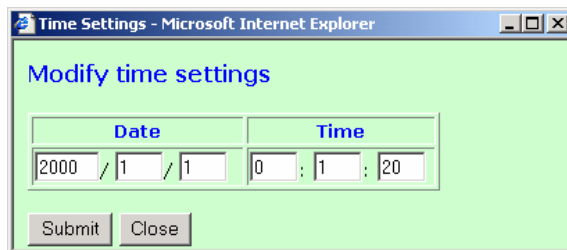

**Time server** (default = blank): This optional field is for your time server’s IP address or domain name, if a time server is used in your network. The NPort 5600-8-DT/DTL supports SNTP (RFC-1769) for automatic time calibration. The device server will request time information from the specified time server every 10 minutes.

**Web console** (default = Enable): This field enables or disables access to the web console.

**Serial console** (default = Enable): This field enables or disables access to the serial console (applies to DTL models only)

**Telnet console** (default = Enable): This field enables or disables access to the Telnet console.

**LCM password protect** (default = No): This field enables or disables password protection for the LCM console. The LCM console refers to the LCD control panel on the top panel of the device server, which may be used for basic configuration.

**Reset button protect** (default = No): This field enables or disables reset button operation.



### ATTENTION

If you disable both the web console and Telnet console, you can still use the LCM console or NPort Administrator to configure your NPort device server.

## Network Settings

**IP Address** (default = 192.168.127.254): This field is for the IP address that will be assigned to your NPort device server. All device ports on the device server will share this IP address. An IP address is a number assigned to a network device (such as a computer) as a permanent address on the network. Computers use the IP address to identify and talk to each other over the network. Choose a proper IP address that is unique and valid in your network environment. If your device server will be assigned a dynamic IP address, set the "IP configuration" parameter appropriately.



### ATTENTION

You must assign a valid IP address to your NPort 5600-8-DT/DTL before it will work in your network environment. Your network system administrator should provide you with a unique IP address and related settings for your network

**Netmask** (default = 255.255.255.0): This field is for the subnet mask. A subnet mask represents all of the network hosts at one geographic location, in one building, or on the same local area network. When a packet is sent out over the network, the NPort device server will use the subnet mask to check whether the desired TCP/IP host specified in the packet is on the local network segment. If the address is on the same network segment as the device server, a connection is established directly from the device server. Otherwise, the connection is established through the gateway as specified in the "Gateway" parameter.

**Gateway** (default = blank): This field is for the IP address of the gateway, if applicable. A gateway is a network computer that acts as an entrance to another network. Usually, the computers that control traffic within the network or at the local Internet service provider are gateway nodes. The NPort device server needs to know the



IP address of the default gateway computer in order to communicate with the hosts outside the local network environment. Consult your network administrator if you do not know how to set this parameter.

**IP configuration** (default = Static): This field determines how the device server's IP address will be assigned. Four options are available:

Option	Description
<b>Static</b>	User-defined IP address, netmask, gateway.
<b>DHCP</b>	DHCP server-assigned IP address, netmask, gateway, DNS, and time server
<b>DHCP/BOOTP</b>	DHCP server-assigned IP address, netmask, gateway, DNS, and time server, or BOOTP server-assigned IP address (if the DHCP server does not respond)
<b>BOOTP</b>	BOOTP server-assigned IP address

**DNS server 1** (default = blank): This field is for the DNS server's IP address, if applicable. This allows the NPort device server to use domain names instead of IP addresses to access hosts.

Domain Name System (DNS) is the way that Internet domain names are identified and translated into IP addresses. A domain name is an alphanumeric name, such as www.moxa.com, that it is usually easier to remember than the numeric IP address. A DNS server is a host that translates a text-based domain name into an IP address in order to establish a TCP/IP connection. When the user wants to visit a particular website, the user's computer sends the domain name (e.g., www.moxa.com) to a DNS server to request that website's numeric IP address. When the IP address is received from the DNS server, the user's computer uses that information to connect to the website's web server.

The NPort will play the role of a DNS client, actively querying the DNS server for the IP address associated with a particular domain name. The following device server parameters on the NPort 5600-8-DT/DTL support the use of domain names in place of IP addresses: Time Server, Destination IP Address (in TCP Client mode), Mail Server, SNMP Trap Server, Destination Address (in Pair Connection mode), and SMTP Server.

**DNS server 2:** This is field is for an alternate DNS server's IP address, if applicable.

**Community name** (default = public): This optional field is for the community name, which is a plain-text password mechanism for weak authentication of queries to agents of managed network devices.

**Contact** (default = blank): This optional field is for SNMP contact information, such as an emergency contact name and telephone or pager number.

**Location** (default = blank): This optional field may be used to specify the location string for SNMP agents. This string is usually set to the street address where the NPort is physically located.

#### **IP Address Reports:**

The IP Address report settings are used when the NPort's IP address is configured by DHCP or BOOTP (i.e., dynamic rather than static IP address). Using these settings, the NPort can be configured to send periodic IP address reports to a network host. For example, if the NPort is operating as a server (TCP or UDP modes), then the host, operating as a client, must know the NPort's IP address. If the DHCP server assigns a new IP address to NPort, the host needs to be notified of the NPort's new IP address. The IP address reports can be used to resolve this situation.

Please refer to Chapter 8 for details on receiving automatic IP reports in NPort Administrator. Please refer to Appendix C for details on the IP report protocol.

The NPort's IP address report must be received by a network host using one of the following methods:

- The host is using NPort Administrator's IP Address Report function.
- The host is running a user-developed application that uses the IP report protocol. Please refer to Appendix C for information about the IP report protocol.

**Auto report to IP** (default = blank) This optional field specifies the destination IP address for the IP address report.

**Auto report to UDP port** (default = blank): This optional field specifies the UDP port number to use when sending IP address reports.

**Auto report period** (default = 10 seconds): This optional field specified how often to send IP address reports.

# Serial Settings

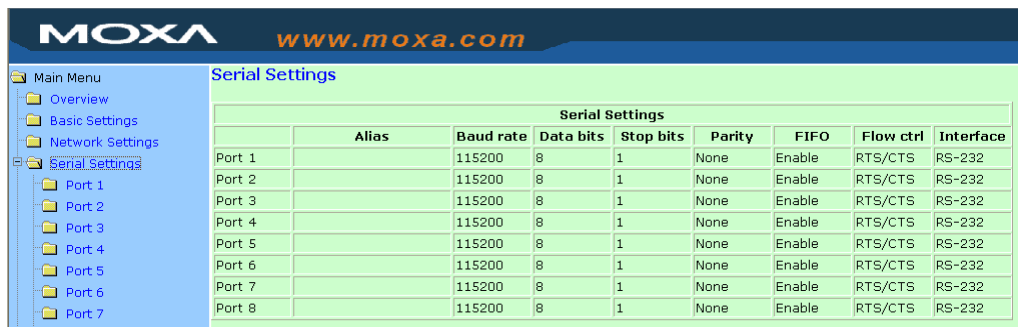

The screenshot shows the MOXA Serial Settings overview page. It features a table with columns for Alias, Baud rate, Data bits, Stop bits, Parity, FIFO, Flow ctrl, and Interface. The table lists settings for Port 1 through Port 8, all with a Baud rate of 115200, 8 Data bits, 1 Stop bit, None Parity, Enable FIFO, and RTS/CTS Flow control. The Interface for all ports is RS-232.

	Alias	Baud rate	Data bits	Stop bits	Parity	FIFO	Flow ctrl	Interface
Port 1		115200	8	1	None	Enable	RTS/CTS	RS-232
Port 2		115200	8	1	None	Enable	RTS/CTS	RS-232
Port 3		115200	8	1	None	Enable	RTS/CTS	RS-232
Port 4		115200	8	1	None	Enable	RTS/CTS	RS-232
Port 5		115200	8	1	None	Enable	RTS/CTS	RS-232
Port 6		115200	8	1	None	Enable	RTS/CTS	RS-232
Port 7		115200	8	1	None	Enable	RTS/CTS	RS-232
Port 8		115200	8	1	None	Enable	RTS/CTS	RS-232

**Serial Settings** is where you set the serial communication parameters for each device port, such as baudrate, parity, and flow control. Each device port can be configured independently.



## ATTENTION

It is critical that the device port's serial communication settings match the attached device. Please refer to the user's manual for your device to verify the serial communication settings.



The screenshot shows the configuration form for Port 1. It includes a 'Port alias' text field, a 'Serial Parameters' section with dropdown menus for Baud rate (115200), Data bits (8), Stop bits (1), Parity (None), and Flow control (RTS/CTS). There are radio buttons for FIFO (Enable/Disable) and a dropdown for Interface (RS-232). A checkbox for 'Apply the above settings to all serial ports' is present, along with a 'Submit' button.

**Port alias** (default = blank): This optional text field can be used to help you differentiate one device port from another.

**Baudrate** (default = 115.2 Kbps): This field is required.

**Data bits** (default = 8): This field is required.

**Stop bits** (default = 1): This field is required.

**Parity** (default = None): This a required field.

**Flow control** (default = RTS/CTS): This is a required field.

**FIFO** (default = Enable): This is a required field. A 128-byte FIFO is provided for each device port in both Tx and Rx directions. Disable the FIFO if the attached serial device does not have its own FIFO to prevent data loss during communication.

**Interface** (default = RS-232): This is a required field. For the NPort 5610-8-DT/DTL and 5610-8-DT-J, only the RS-232 setting is available.

# Operating Settings

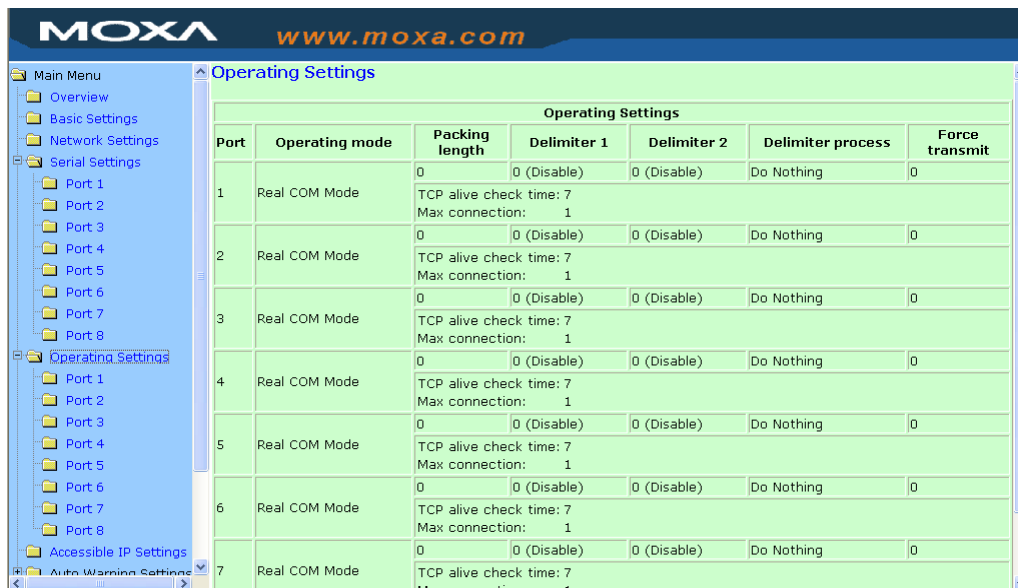

**Operating Settings** is where each device port's operation mode and associated parameters are configured. Please refer to Chapters 5 and 6 for an explanation of the different operating modes and parameters.

# Accessible IP Settings



The Accessible IP list allows you enable only certain IP addresses to connect to the NPort device server and attached devices. When the accessible IP list is enabled, only IP addresses that are on the list will be able to connect to the NPort. You can allow single IP addresses or a range of IP addresses by using a combination of IP address and netmask, as follows:

- **To allow access to a specific IP address**  
Enter the exact IP address and enter 255.255.255.255 for the netmask.
- **To allow access to hosts on a specific subnet**  
For both the IP address and netmask, use 0 for the last digit (e.g., 192.168.1.0 and 255.255.255.0).
- **To allow unrestricted access**  
Do not enable the accessible IP list.

The following table shows additional examples:

Allowed hosts	IP Address setting	Netmask setting
Any host	(disable)	(disable)
192.168.1.120	192.168.1.120	255.255.255.255
192.168.1.1 to 192.168.1.254	192.168.1.0	255.255.255.0
192.168.0.1 to 192.168.255.254	192.168.0.0	255.255.0.0
192.168.1.1 to 192.168.1.126	192.168.1.0	255.255.255.128
192.168.1.129 to 192.168.1.254	192.168.1.128	255.255.255.128

## Auto Warning Settings

The NPort device server can automatically warn administrators of certain system, network, and configuration events. Depending on the event, different options for automatic notification are available, as shown above. These options are configured in the Auto Warning Settings.

### Email and SNMP trap

The Email and SNMP trap parameters are used to configure how e-mail and SNMP traps are sent when an automatic warning is issued by the NPort device server.

**Mail Server** (default = blank): This optional field is for the IP address or domain name of your network mail server, if applicable. The mail server is required for the NPort to send e-mail warnings of administrative events.

**User name** (default = blank): This optional field is used if your mail server requires it.

**Password** (default = blank): This optional field is used if your mail server requires it.

**From E-mail address** (default = blank): This optional field sets the "From" e-mail address that will show up in an automatic warning e-mail.

**E-mail address 1 through 4** (default = blank): These optional fields set the destination e-mail address for automatic e-mail warnings.



#### ATTENTION

Consult your network administrator or ISP if you are unsure how to set the mail server settings. The NPort's automatic warning function may not work properly if the settings are incorrect. The NPort supports SMTP AUTH with LOGIN, PLAIN, CRAM-MD5 (RFC 2554).

**SNMP trap server** (default = blank): This optional field is for the IP address or domain name of your SNMP trap server, if applicable. The SNMP trap server is required for the NPort to send SNMP traps for certain administrative events.

## Event Type

Event Type		
Cold start	<input type="checkbox"/> Mail	<input type="checkbox"/> Trap
Warm start	<input type="checkbox"/> Mail	<input type="checkbox"/> Trap
Authentication failure	<input type="checkbox"/> Mail	<input type="checkbox"/> Trap
IP address changed	<input type="checkbox"/> Mail	
Password changed	<input type="checkbox"/> Mail	
Ethernet1 link down	<input type="checkbox"/> Mail	<input type="checkbox"/> Trap
Ethernet2 link down	<input type="checkbox"/> Mail	<input type="checkbox"/> Trap
<b>DCD changed</b>		
Port 1	<input type="checkbox"/> Mail	<input type="checkbox"/> Trap
Port 2	<input type="checkbox"/> Mail	<input type="checkbox"/> Trap
Port 3	<input type="checkbox"/> Mail	<input type="checkbox"/> Trap
Port 4	<input type="checkbox"/> Mail	<input type="checkbox"/> Trap
Port 5	<input type="checkbox"/> Mail	<input type="checkbox"/> Trap
Port 6	<input type="checkbox"/> Mail	<input type="checkbox"/> Trap
Port 7	<input type="checkbox"/> Mail	<input type="checkbox"/> Trap
Port 8	<input type="checkbox"/> Mail	<input type="checkbox"/> Trap
<b>DSR changed</b>		
Port 1	<input type="checkbox"/> Mail	<input type="checkbox"/> Trap
Port 2	<input type="checkbox"/> Mail	<input type="checkbox"/> Trap
Port 3	<input type="checkbox"/> Mail	<input type="checkbox"/> Trap
Port 4	<input type="checkbox"/> Mail	<input type="checkbox"/> Trap
Port 5	<input type="checkbox"/> Mail	<input type="checkbox"/> Trap
Port 6	<input type="checkbox"/> Mail	<input type="checkbox"/> Trap
Port 7	<input type="checkbox"/> Mail	<input type="checkbox"/> Trap
Port 8	<input type="checkbox"/> Mail	<input type="checkbox"/> Trap

The Event Type parameters are used to configure which events will generate an automatic warning from the NPort device server, and how that warning will be issued. For each listed event, certain automatic warning options are available. If **Mail** is selected, an e-mail will be sent. If **Trap** is selected, an SNMP trap will be sent.

**Cold start:** The NPort has booted up after being powered off.

**Warm start:** The NPort has rebooted without turning the power off.

**Authentication failure:** The user has entered the wrong password when trying to access the NPort configuration parameters from NPort Administrator or one of the consoles (e.g., web console).

**IP address changed:** The user has changed the NPort's IP address. Please note that for this event, the NPort will reboot with the new IP address without sending an automatic warning e-mail if the NPort is unable to reach the mail server within 15 seconds.

**Password changed:** The user has changed NPort's password. Please note that for this event, the NPort will reboot with the new password without sending an automatic warning e-mail if the NPort is unable to reach the mail server within 15 seconds.

**Ethernet1, Ethernet 2 link down:** The Ethernet connection is down or the Ethernet cable has been disconnected.

**DCD changed, Ports 1 through 8:** The device port's DCD (Data Carrier Detect) signal has changed, or the modem connection status has changed. For example, a DCD change to high indicates that the attached modem has established a valid connection to another modem. A DCD change to low indicates that the connection line is down.

**DSR changed, Ports 1 through 8:** The device port's DSR (Data Set Ready) signal has changed, or the attached device has no power. For example, a DSR change to high indicates that the DCE (Data Communication Equipment) is powered on. A DSR change to low indicates that the DCE is powered off.

**ATTENTION**

DCD and DSR signal changes are only applicable for the RS-232 interface.

## Change Password

The screenshot shows the MOXA web interface. At the top, the MOXA logo and the website URL 'www.moxa.com' are displayed. On the left, there is a navigation menu with categories like 'Main Menu', 'Overview', 'Basic Settings', 'Network Settings', 'Serial Settings', 'Operating Settings', 'Accessible IP Settings', and 'Auto Warning Settings'. The main content area is titled 'Change password' and contains three input fields labeled 'Old password', 'New password', and 'Retype password'. A 'Submit' button is located at the bottom right of the form.

You can set a password to restrict access to the NPort's configuration parameters. If a user does not enter the password, access to the NPort configuration settings will be denied, whether it is through NPort Administrator or through one of the consoles (e.g., web console). In order to remove password protection, leave the **New password** and **Retype password** parameters blank.

**ATTENTION**

If you forget the NPort's password, the **ONLY** way to configure the NPort is by using the hardware reset button load the factory defaults.

Before you set a password for the first time, it is a good idea to export the NPort's completed configuration to a file. Your configuration can then be easily restored if necessary. For additional information on configuration management, please refer to Chapter 8.

# Introduction to Operation Modes

---

In this chapter, we describe the various device port operation modes available on NPort 5600-8-DT/DTL device servers. The operation mode determines how the device port will interact with the network. The selection of operation mode will depend on your specific application. After choosing the proper operation mode in this chapter, please refer to Chapter 6 for information on configuring the operation mode advanced settings.

The following topics are covered in this chapter:

- ❑ **Overview**
- ❑ **Real COM Mode**
- ❑ **RFC2217 Mode**
- ❑ **TCP Server Mode**
- ❑ **TCP Client Mode**
- ❑ **UDP Mode**
- ❑ **Pair Connection Modes**
- ❑ **Reverse Telnet Mode**
- ❑ **Disabled Mode**

## Overview

The NPort 5600-8-DT/DTL connects RS-232/422/485 devices to an Ethernet network. In a typical application, a traditional SCADA and data collection system relies on serial devices to collect data from various kinds of instruments. With the NPort device server, the SCADA and data collection system can access instrument data over a standard TCP/IP network, whether the devices are used locally or at a remote site.

Each device port on the NPort 5600-8-DT/DTL is configured independently of the other device ports, with its own serial communication parameters and operation mode. A device port's operation mode determines how it interacts with the network, and different modes are available to encompass a wide variety of applications and devices.

**Real COM** and **RFC2217** modes allow serial-based software to access the device port as if it were a local serial port on a PC. These modes are appropriate when your application relies on Windows or Linux software that was originally designed for locally attached COM or TTY devices. With these modes, you can access your devices from the network using your existing COM/TTY-based software, without investing in additional software.

Three different socket modes are available for user-developed socket programs: **TCP Server**, **TCP Client**, and **UDP Server/Client**. For TCP applications, the appropriate mode depends on whether the connection will be hosted or initiated from the device port or from the network. The main difference between the TCP and UDP protocols is that TCP guarantees delivery of data by requiring the recipient to send an acknowledgement to the sender. UDP does not require this type of verification, making it possible to offer speedier delivery. UDP also allows multicasting of data to groups of IP addresses and would be suitable for streaming media or non-critical messaging applications such as LED message boards.

**Pair Connection** Slave and Master modes are designed for serial-to-serial communication over Ethernet, in order to overcome traditional limitations with serial transmission distance.

**Reverse Telnet** mode is designed for connections to servers that will host terminal sessions through the device port. This mode is typically used for console management applications, but can also be used to upgrade legacy servers to network operation.

## Real COM Mode

Real COM mode is designed to work with NPort drivers that are installed on a network host. COM drivers are provided for Windows systems, and TTY drivers are provided for Linux systems. The driver establishes a transparent connection to the attached serial device by mapping a local serial port to the device port's IP:Port. Real COM mode supports up to four simultaneous connections, so multiple hosts can collect data from the attached device at the same time.

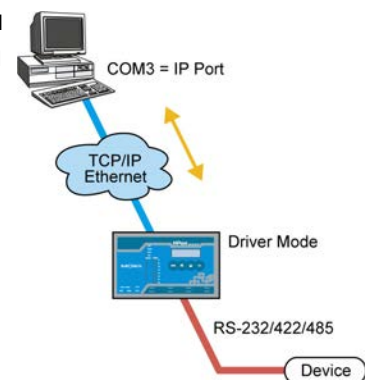

### ATTENTION

Real COM drivers are installed automatically with NPort Administrator.

Real COM mode allows you to continue using your serial communications software to access devices that are now attached to your NPort device server. On the host, the NPort Real COM driver automatically intercepts data sent to the COM port, packs it into a TCP/IP packet, and redirects it to the network. At the other end of the connection, the NPort device server accepts the Ethernet frame, unpacks the TCP/IP packet, and sends the serial data to the appropriate device.





**ATTENTION**

In Real COM mode, several hosts can have simultaneous access control over the device port. If necessary, you can limit access by using the Accessible IP settings. Please refer to Chapter 4 for additional information about Accessible IP settings.

## RFC2217 Mode

RFC-2217 mode is similar to Real COM mode, since it relies on a driver to transparently map the device port to a virtual COM port on a host computer. The RFC2217 standard defines general COM port control options based on the Telnet protocol and supports one connection at a time. Third party drivers supporting RFC-2217 are widely available on the Internet and can be used to implement virtual COM mapping.

## TCP Server Mode

In TCP Server mode, the device port is assigned an IP:Port address that is unique on your TCP/IP network. It waits for the host computer to establish a connection to the attached serial device. This operation mode also supports up to four simultaneous connections, so multiple hosts can collect data from the attached device at the same time.

Data transmission proceeds as follows:

A host requests a connection to the device port.

Once the connection is established, data can be transmitted in both directions—from the host to the device, and from the device to the host.

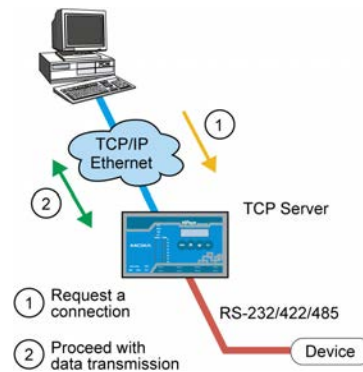

## TCP Client Mode

In TCP Client mode, the NPort actively establishes a TCP connection to a specific network host when data is received from the attached serial device. After the data has been transferred, the NPort can automatically disconnect from the host computer through the Inactivity time settings. Please refer to Chapter 6 for details on these parameters.

Data transmission proceeds as follows:

The NPort requests a connection from the host.

The connection is established and data can be transmitted in both directions between the host and device.

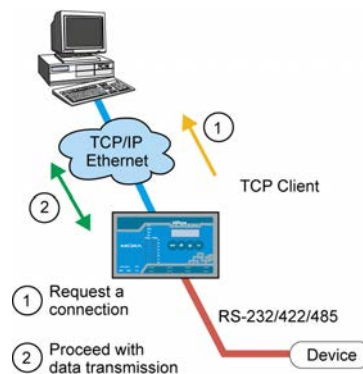

## UDP Mode

UDP is similar to TCP but is faster and more efficient. Data can be broadcast to or received from multiple network hosts. However, UDP does not support verification of data and would not be suitable for applications where data integrity is critical. It is ideal for message display applications.

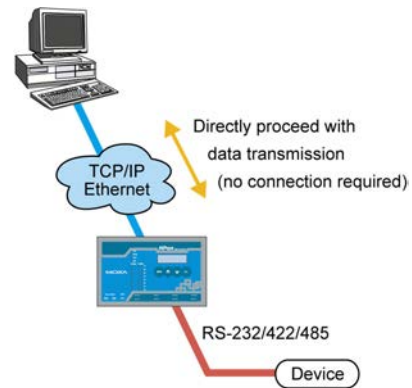

## Pair Connection Modes

Pair Connection Master and Slave modes connect two NPort device servers over Ethernet for serial-to-serial communication. The two NPort device servers can connect to each other with a Ethernet cable, connect to the same LAN, or in a more advanced setup, communicate to each other over a WAN (i.e., through one or more routers). A device attached to one NPort can then communicate transparently to a device attached to the other NPort, as if the two devices were connected by a serial cable. Both data and modem control signals are exchanged, except for DCD signals. This can be used to overcome traditional limitations with serial communication distance and introduces many new possibilities for serial-based device control.

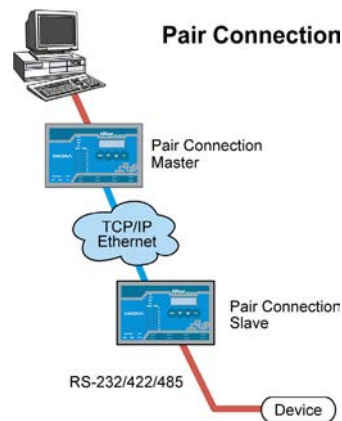

## Reverse Telnet Mode

In Reverse Telnet mode, the device port is connected to a server and waits for a terminal session to from a host on the network. This is an appropriate mode for console management, with device ports connected to the console/AUX or COM ports of routers, switches, or UPS units. Unlike TCP Server mode, Reverse Telnet mode assists with CR/LF conversion.

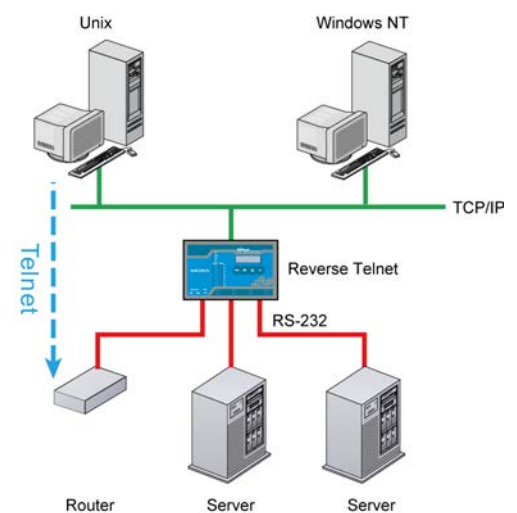

## Disabled Mode

A device port can be disabled by selecting the Disabled operation mode.

# Operation Mode Advanced Settings

---

Each device port on NPort 5600-8-DT/DTL device servers operate in one of the available operation modes, such as Real COM mode or Reverse Telnet mode. For each operation mode, different parameters can be configured. This chapter explains the settings for every parameter for every operation mode.

The following topics are covered in this chapter:

## ❑ Overview

- List of Parameters
- When to Make Adjustments

## ❑ Using Pair Connection Modes

## ❑ Parameter Details

- Connection Management Parameters
- Data Packing Parameters
- Other Parameters

# Overview

The device port operation mode determines how the port interacts with the network. Depending on your application and device, more than one operating mode may be suitable. When setting the operation mode, different parameters may be adjusted depending on the operation mode.

For each mode, the default settings should work for most applications. Modify these settings only if absolutely necessary for your application. The operation mode and related parameters can be configured through NPort Administrator. The same parameters may also be configured using the web console, Telnet console, or serial console.

## List of Parameters

Real COM Mode	TCP Server Mode	TCP Client Mode	UDP Mode	Reverse Telnet Mode	Pair Connection Mode	RFC2217 Mode	
							<b>Connection Management Parameters</b>
✓	✓	✓		✓	✓	✓	TCP alive check time
	✓	✓		✓			Inactivity time
✓	✓	✓					Max connection
✓	✓	✓					Ignore jammed IP
✓	✓						Allow driver control
							<b>Data Packing Parameters</b>
✓	✓	✓	✓			✓	Packing length
✓	✓	✓	✓			✓	Delimiter 1 and 2
✓	✓	✓	✓			✓	Delimiter process
✓	✓	✓	✓			✓	Force transmit
							<b>Other Parameters</b>
	✓			✓	✓		Local TCP port
	✓						Command port
					✓		Destination IP address
		✓	✓				Destination IP address 1 through 4
		✓					Designated local port 1 through 4
			✓				Local listen port
		✓					Connection Control
				✓			Map <CR-LF>

## When to Make Adjustments

The default settings for each operation mode are designed to work for most applications, and usually do not need to be modified. However, adjustments may be required for the following situations:

- You need to control network data packing using specific delimiter characters. Adjust **Delimiters 1 and 2 and Delimiter process**.
- Multiple hosts will simultaneously access the attached device. Adjust **Max Connection, Ignore Jammed IP, and Allow driver control**.
- Data will be broadcast from the serial device to multiple network destinations. Adjust **Destination IP 1 through 4**.

- You are using Pair Connection modes to connect two serial devices over Ethernet. Adjust **Local TCP port** and **Destination IP Address**.

## Using Pair Connection Modes

For some applications, you may simply want a serial device to communicate directly to another serial device over the network. You can use a pair of NPort 5600-8-DT/DTL device servers to accomplish this, with Pair Connection Master and Slave modes. Simply set one device port to Pair Connection Master mode and the other device port to Pair Connection Slave mode. It does not matter which device port is master and which is slave.

For the device port in Pair Connection Slave mode, designate a **Local TCP port** to be used for communication. For the device port in Pair Connection Master mode, enter the slave's IP address and Local TCP port as the **Destination IP**.

Once both device ports have been configured, the attached serial devices will communicate over Ethernet as if they were connected by a serial cable. The two device servers can be connected by an Ethernet cable, or they can be connected to the same network.

## Parameter Details

### Connection Management Parameters

✓	✓	✓		✓	✓	✓	<b>TCP alive check time</b>
Real COM Mode	TCP Server Mode	TCP Client Mode	UDP Mode	Reverse Telnet Mode	Pair Connection Mode	RFC2217 Mode	Range: 0 to 99 minutes Default: 7 minutes Description: This is the time limit for keeping the connection open if a host does not respond to "TCP alive check" packets. If the host does not respond within the specified time, the connection will be closed. A setting of 0 means that the connection will remain open even if the host never responds.

	✓	✓		✓			<b>Inactivity time</b>
Real COM Mode	TCP Server Mode	TCP Client Mode	UDP Mode	Reverse Telnet Mode	Pair Connection Mode	RFC2217 Mode	Range: 0 to 65535 ms Default: 0 Description: This specifies the time limit for keeping the connection open if no data flows to or from the serial device. If there is no activity for the specified time, the connection will be closed. A setting of 0 means that the connection will remain open even if data is never received.  For many applications, the serial device may be idle for long periods of time, so 0 is an appropriate setting. If you wish to use Inactivity time with TCP Client mode, you must set Connection Control is to Any Character/Inactivity Time (see Connection Control).  When adjusting Inactivity time, make sure that it is greater than the Force transmit time. Otherwise, the TCP connection may be closed before data in the buffer can be transmitted.

✓	✓	✓					<b>Max connection</b>
Real COM Mode	TCP Server Mode	TCP Client Mode	UDP Mode	Reverse Telnet Mode	Pair Connection Mode	RFC2217 Mode	Range: 1 to 4 Default: 1 Description: This specifies the maximum number of simultaneous connections that the port will accept. When adjusting Max connection, make sure that Ignore jammed IP and Allow driver control are also adjusted correctly.

✓	✓	✓					<b>Ignore jammed IP</b>
Real COM Mode	TCP Server Mode	TCP Client Mode	UDP Mode	Reverse Telnet Mode	Pair Connection Mode	RFC2217 Mode	Range: Yes or No Default: No Description: This field specifies how an unresponsive IP address is handled when there are simultaneous connections to the device port (see Max connection). "Yes" means that transmission to the other hosts will not be suspended if one IP address becomes unresponsive. "No" means that all transmission will be suspended if one IP address becomes unresponsive, and will resume when all hosts have responded. "Yes" is the recommended setting when Max connection is 2 or more.

✓	✓						<b>Allow driver control</b>
Real COM Mode	TCP Server Mode	TCP Client Mode	UDP Mode	Reverse Telnet Mode	Pair Connection Mode	RFC2217 Mode	Range: Yes or No Default: No Description: This specifies whether the device port will respond to driver control commands when multiple simultaneous connections are enabled (see Max connection).

### Data Packing Parameters

✓	✓	✓	✓			✓	<b>Packing length</b>
Real COM Mode	TCP Server Mode	TCP Client Mode	UDP Mode	Reverse Telnet Mode	Pair Connection Mode	RFC2217 Mode	Range: 0 to 1024 Default: 0 Description: This controls data packing by the amount of data received. Serial data accumulates in the device port's buffer until it reaches the specified length. When the specified amount of data has accumulated in the buffer, the data is packed for network transmission. A setting of 0 means that data will not be packed until the buffer is full. 0 is the recommended setting, unless your application has a specific need to limit packet sizes or improve response times.

✓	✓	✓	✓			✓	<b>Delimiter 1 and 2</b>
Real COM Mode	TCP Server Mode	TCP Client Mode	UDP Mode	Reverse Telnet Mode	Pair Connection Mode	RFC2217 Mode	<p>Range: 0 to FF, Enable                      Default: Disabled                      Description: This controls data packing by special delimiter character(s).                      Serial data accumulates in the device port's buffer until the delimiter character(s) are received, after which the data is packed for network transmission. If only one delimiter character is needed, be sure to enable Delimiter 1 only. If both Delimiter 1 and 2 are enabled, both characters must be received in sequence for data packing to occur. For example, the carriage return character could be used as a delimiter in order to transmit each sentence or paragraph in a separate packet. Data is packed according to the Delimiter process parameter.                      Delimiters must be incorporated into the data stream at the software or device level.</p>



**ATTENTION**

When the device port buffer is full, the data will be packed for network transmission, regardless of the settings for Delimiter 1, Delimiter 2, and Force transmit.

✓	✓	✓	✓			✓	<b>Delimiter process</b>
Real COM Mode	TCP Server Mode	TCP Client Mode	UDP Mode	Reverse Telnet Mode	Pair Connection Mode	RFC2217 Mode	<p>Range: Do Nothing, Delimiter + 1, Delimiter + 2, Strip Delimiter                      Default: Do Nothing                      Description: This controls how data is packed when delimiter characters are received. Note that this field has no effect if delimiters are not enabled (see Delimiters 1 and 2).                      "Do nothing" will pack the accumulated data including delimiters.                      "Delimiter + 1" will wait for an additional character before packing the accumulated data.                      "Delimiter + 2" will wait for two additional characters before packing the accumulated data.                      "Strip Delimiter" will pack the accumulated data but will not include the delimiter characters in the packet.</p>

✓	✓	✓	✓			✓	<b>Force transmit</b>
Real COM Mode	TCP Server Mode	TCP Client Mode	UDP Mode	Reverse Telnet Mode	Pair Connection Mode	RFC2217 Mode	<p>Range: 0 to 65535 ms                      Default: 0 ms                      Description: This controls data packing by the amount of time that elapses between bits of data. As serial data is received, it accumulates in the device port's buffer. If serial data is not received for the specified amount of time, the data that is currently in the buffer is packed for network transmission. A setting of 0 means that data in the buffer will not be automatically packed when no further data is received from the device. When using this field, make sure that Inactivity time is disabled or set to a larger value. Otherwise the connection may be closed before the data in the buffer can be transmitted.</p>

## Other Parameters

	↙			↙	↙		<b>Local TCP port</b>
Real COM Mode	TCP Server Mode	TCP Client Mode	UDP Mode	Reverse Telnet Mode	Pair Connection Mode	RFC2217 Mode	<p>Range: 1 to 65535</p> <p>Default: 4001 for port 1, 4002 for port 2, etc.</p> <p>Description: This specifies the TCP port number for communication to the attached device. Socket applications will need to refer to the device using this port number. For Pair Connection modes, this field specifies the slave's port number, and the same value must be used for the master's Destination IP parameter.</p>

	↙						<b>Command port</b>
Real COM Mode	TCP Server Mode	TCP Client Mode	UDP Mode	Reverse Telnet Mode	Pair Connection Mode	RFC2217 Mode	<p>Range: 1 to 65535</p> <p>Default: 966</p> <p>Description: This specifies the TCP port number for Moxa IP-Serial Library commands. You do not need to reference this port number in your application when using the Moxa IP-Serial Library, since the library automatically obtains the number from the device server. Change this setting only if there is a port number conflict with another application or device.</p>

					↙		<b>Destination IP address</b>
Real COM Mode	TCP Server Mode	TCP Client Mode	UDP Mode	Reverse Telnet Mode	Pair Connection Mode	RFC2217 Mode	<p>Range: N/A</p> <p>Default: none</p> <p>Description: This specifies the IP address for the slave end of a pair connection.</p>

		↙	↙				<b>Destination IP address 1 through 4</b>
Real COM Mode	TCP Server Mode	TCP Client Mode	UDP Mode	Reverse Telnet Mode	Pair Connection Mode	RFC2217 Mode	<p>Range: N/A</p> <p>Default: none</p> <p>Description: This specifies the network host(s) that will access the device. Serial data will be transmitted to every address listed, and network data will be sent to the device on a first-in-first-out basis.</p>

		↙					<b>Designated local port 1 through 4</b>
Real COM Mode	TCP Server Mode	TCP Client Mode	UDP Mode	Reverse Telnet Mode	Pair Connection Mode	RFC2217 Mode	<p>Range: 1 to 65535</p> <p>Default: none</p> <p>Description: This specifies the TCP port number that will be used for data transmission with the device port.</p>



			✓				<b>Local listen port</b>
Real COM Mode	TCP Server Mode	TCP Client Mode	UDP Mode	Reverse Telnet Mode	Pair Connection Mode	RFC2217 Mode	<p>Range: 1 to 65535</p> <p>Default: 4001 for port 1, 4002 for port 2, etc.</p> <p>Description: This specifies the UDP port number for network communication to the serial device. Socket applications will need to refer to the device using this port number.</p>

		✓					<b>Connection Control</b>
Real COM Mode	TCP Server Mode	TCP Client Mode	UDP Mode	Reverse Telnet Mode	Pair Connection Mode	RFC2217 Mode	<p>Range: Startup/None, Any Character/None, Any Character/Inactivity Time, DSR On/DSR Off, DSR On/None, DCD On/DCD Off, DCD On/None</p> <p>Default: Startup/None</p> <p>Description: This specifies how connections to the device are established and closed.</p> <p>For example, "Startup/None" means that as soon as the device server starts up, the TCP connection is opened, and the connection can only be closed manually. "DCD On/DCD Off" means that the TCP connection is opened when the DCD signal is on, and closed when the DCD signal is off. If you want to use the Inactivity Time parameter to close the connection when the serial device is inactive, you must set Connection Control to "Any Character/Inactivity time".</p>

				✓			<b>Map &lt;CR-LF&gt;</b>
Real COM Mode	TCP Server Mode	TCP Client Mode	UDP Mode	Reverse Telnet Mode	Pair Connection Mode	RFC2217 Mode	<p>Range: CR, LF, or CR-LF</p> <p>Default: CR-LF</p> <p>Description: This specifies how the ENTER key is mapped from the Ethernet port through the serial port. For certain terminal applications, the Enter key needs to be translated specifically as a CR character rather than CR-LF.</p>

# Using the Web Console

---

The NPort 5600-8-DT/DTL web console allows it to be managed from anywhere on the network using a standard web browser. This chapter explains how to use the web console.

The following topics are covered in this chapter:

- **Overview**
- **Web Browser Settings**
- **Basic Navigation**
- **Device Server Settings**
- **Special Functions**
  - Monitor
  - Load Factory Defaults

# Overview

The NPort can be configured from anywhere on the network through its web console. Simply point the browser to the device server’s IP address to open the web console. Network settings, operation mode, and other items can all be modified through the browser. This is a handy option for configuration if you cannot or do not wish to install NPort Administrator.



## ATTENTION

All device server settings can be accessed using the web console. However, certain functions such as port monitoring or configuration export are only available through NPort Administrator. Please refer to Chapter 8 for more details on using NPort Administrator.

# Web Browser Settings

In order to use the web console, you will need to have cookies enabled for your browser. Please note that the web console uses cookies only for password transmission. For Internet Explorer, cookies can be enabled by right-clicking the Internet Explorer icon on your desktop and selecting Properties from the context menu.

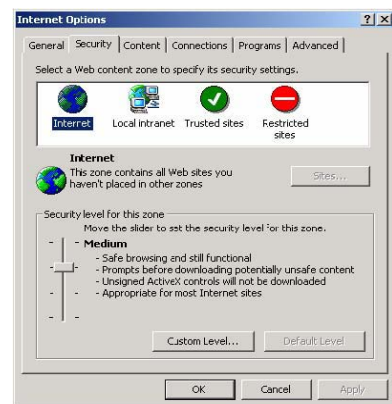

On the Security tab, click “Custom Level...” and enable these two items:

- Allow cookies that are stored on your computer
- Allow per-session cookies (not stored)

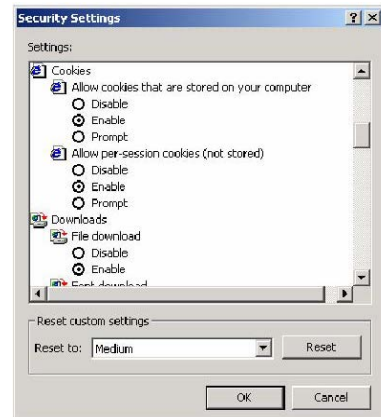

## ATTENTION

If you are not using Internet Explorer, cookies are usually enabled through a web browser setting such as “allow cookies that are stored on your computer” or “allow per-session cookies.”

# Basic Navigation

To open the web console, enter your device server's IP address in the website address line. If you are configuring the NPort for the first time, you will use the default IP address, **192.168.127.254**.

If prompted, enter the console password. You will only be prompted for a password if you have enabled password protection on the device server. The password will be transmitted with MD5 encryption over the Ethernet.

Input password

Password :

The web console will appear as shown below.

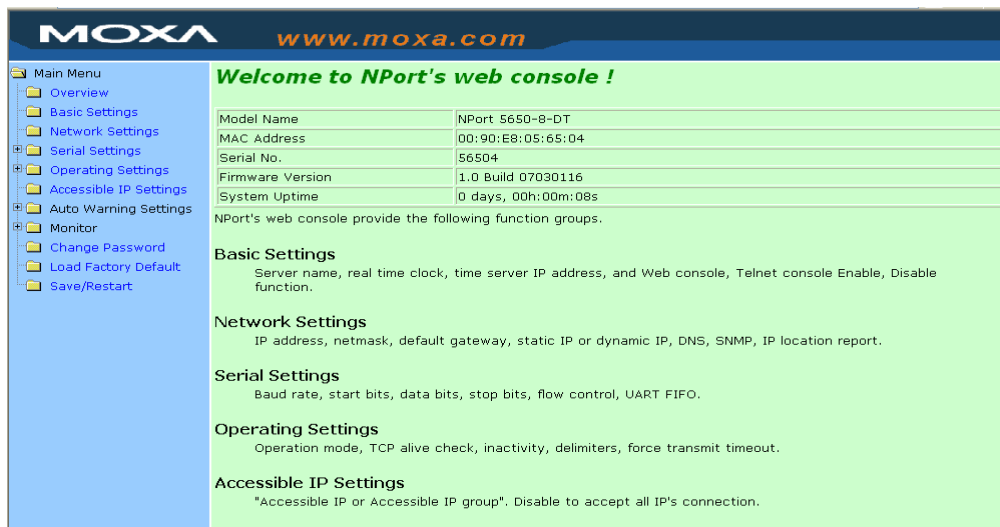

The left panel is the navigation panel, where you select the parameters that you wish to see or modify. Certain folders can be expanded by clicking the adjacent “+” symbol.

The right panel is the main window, where parameters are displayed and modified. For example, if you click **Basic Settings** in the navigation panel, the main window will show a page of basic settings that you can configure.

After you have made changes on a page, you must click the **Submit** button in the main window before jumping to another page. Your changes will be lost if you do not click **Submit**.

After you have finished modifying the desired pages, you must save and restart the device server for the new settings to take effect. You may complete this in one step by clicking **Save/Restart** after you submit a change. Changes will not take effect until they are saved and the NPort is restarted. If you restart the NPort without saving your configuration, all configuration changes will be lost.

# Device Server Settings

Please refer to Chapter 4 for details on the following settings:

- Basic Settings
- Network Settings
- Serial Settings
- Accessible IP Settings
- Auto Warning Settings
- Change Password
- For details on Operating Settings, please refer to Chapter 5.

# Special Functions

There are several special functions that are available in the web console. These functions are not available on NPort Administrator.

## Monitor

Select one of the Monitor functions in the navigation panel to monitor traffic on the NPort device server. Refresh your browser to display updated status.

### Line

Monitor each device port's operation mode and connection status (IPx).

Line						
Port	OP Mode	IP1	IP2	IP3	IP4	
1	Real COM Mode	Listen				
2	Real COM Mode	Listen				
3	Real COM Mode	Listen				
4	Real COM Mode	Listen				
5	Real COM Mode	Listen				
6	Real COM Mode	Listen				
7	Real COM Mode	Listen				
8	Real COM Mode	Listen				

### Async

Monitor each device port's serial signal status.

Async							
Port	TxCnt	RxCnt	TxTotalCnt	RxTotalCnt	DSR	CTS	DCD
1	0	0	0	0	OFF	OFF	OFF
2	0	0	0	0	OFF	OFF	OFF
3	0	0	0	0	OFF	OFF	OFF
4	0	0	0	0	OFF	OFF	OFF
5	0	0	0	0	OFF	OFF	OFF
6	0	0	0	0	OFF	OFF	OFF
7	0	0	0	0	OFF	OFF	OFF
8	0	0	0	0	OFF	OFF	OFF

## Async-Settings

Monitor each device port's serial run-time settings.

Async-Settings								
Port	Baud rate	Data bits	Stop bits	Parity	FIFO	RTS/CTS	XON/XOFF	DTR/DSR
1	38400	8	1	None	Enable	OFF	OFF	OFF
2	115200	8	1	None	Enable	ON	OFF	OFF
3	115200	8	1	None	Enable	ON	OFF	OFF
4	115200	8	1	None	Enable	ON	OFF	OFF
5	115200	8	1	None	Enable	ON	OFF	OFF
6	115200	8	1	None	Enable	ON	OFF	OFF
7	115200	8	1	None	Enable	ON	OFF	OFF
8	115200	8	1	None	Enable	ON	OFF	OFF

## Load Factory Defaults

This function will reset all MOXA NPort Server settings to their factory default values. Be aware that previous settings will be lost.

This will load the NPort's factory default configuration. All parameters will be reset, and the current configuration settings will be lost. It is strongly recommended that you first save your configuration to a file so that it can be restored if necessary. Please refer to Chapter 8 for details on importing and exporting your configuration in NPort Administrator.

# Using NPort Administrator

---

The following topics are covered in this chapter:

- **Overview**
- **Installing NPort Administrator**
- **Basic Navigation**
  - Window Layout
  - Activating a Function
- **Configuration**
  - Finding Your Device Server
  - Status
  - Device Server Parameters
  - Firmware and Configuration Management
- **Monitor**
  - Finding Your Device Server
  - Monitoring Parameters
  - Activating the Monitor
- **Port Monitor**
- **COM Mapping**
  - Finding Your Device Server
  - COM Mapping Settings
  - Saving COM Mapping Settings
- **COM Grouping**
  - Creating a COM Group
  - Deleting a COM Group
  - Adding a Port to a COM Group
  - Removing a Port from a COM Group
  - Modifying Ports in a COM Group
- **IP Address Report**
- **Automatic Message Log**

# Overview

The NPort Administration Suite provides everything you need to manage, monitor, and modify your NPort from a remote location. It includes NPort Administrator and the IP Serial Library.

With NPort Administrator, you can easily install and configure your NPort device server over the network. You can also run NPort Administrator from one location to manage multiple device servers.

# Installing NPort Administrator

NPort Administrator can be installed from the Document and Software CD onto a Windows PC. To install NPort Administration Suite, insert the NPort Document & Software CD into your PC's CD-ROM drive. Locate and run the setup program and follow the on-screen instructions. The setup program will be named **Npadm\_Setup\_[Version]\_Build\_[DateTime].exe** (e.g., "**Npadm\_Setup\_Ver1.8\_Build\_07041316.exe**").

1. When you run the setup program from the Document and Software CD, a **Welcome** window will appear. Click **Next** to proceed.

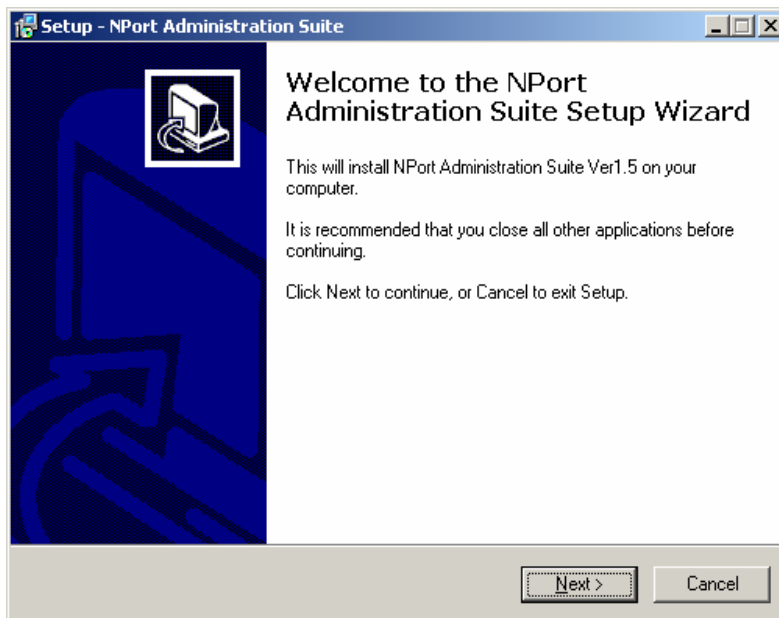

2. Click **Next** to accept the proposed installation directory, or click **Browse...** to select an alternative location.

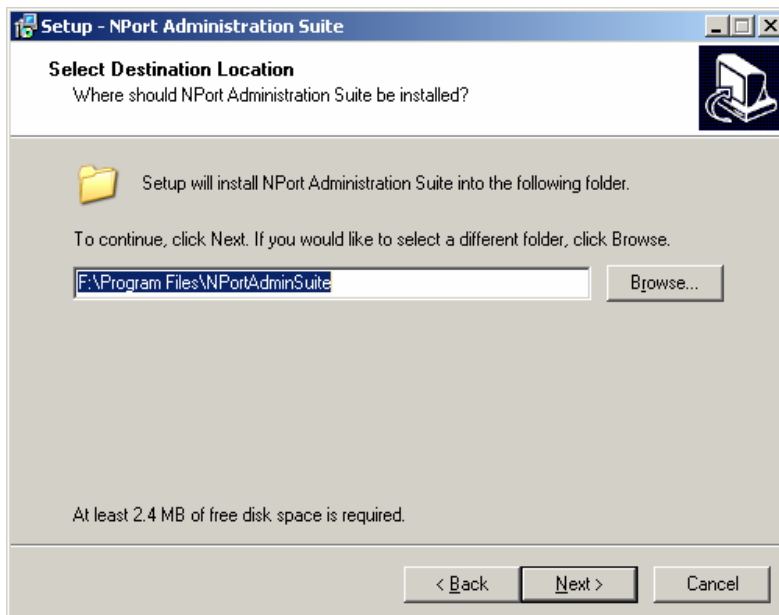



3. Click **Next** to accept the proposed Start menu folder, or select a different folder.

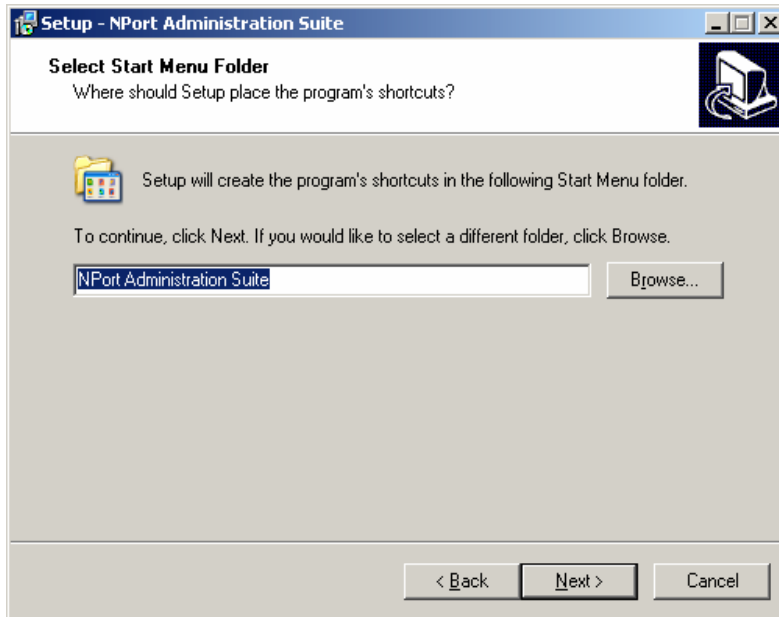

4. Click **Install** to proceed with the installation.

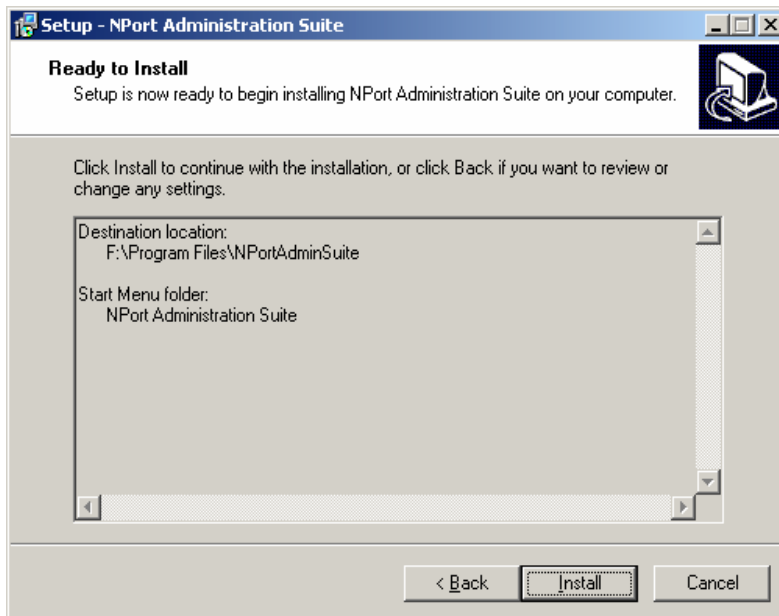

5. The setup wizard will show the progress of the installation.

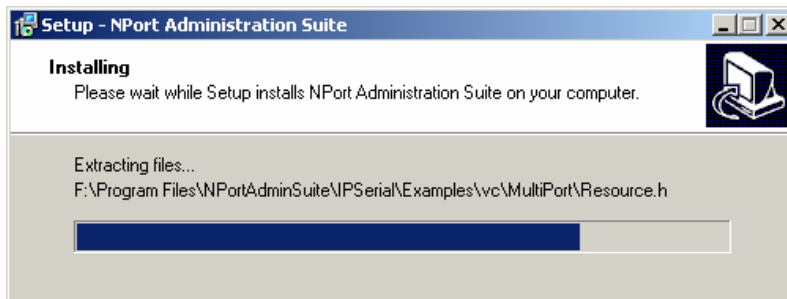

- 6. A special notice will appear. Click **Next** after reading the notice.

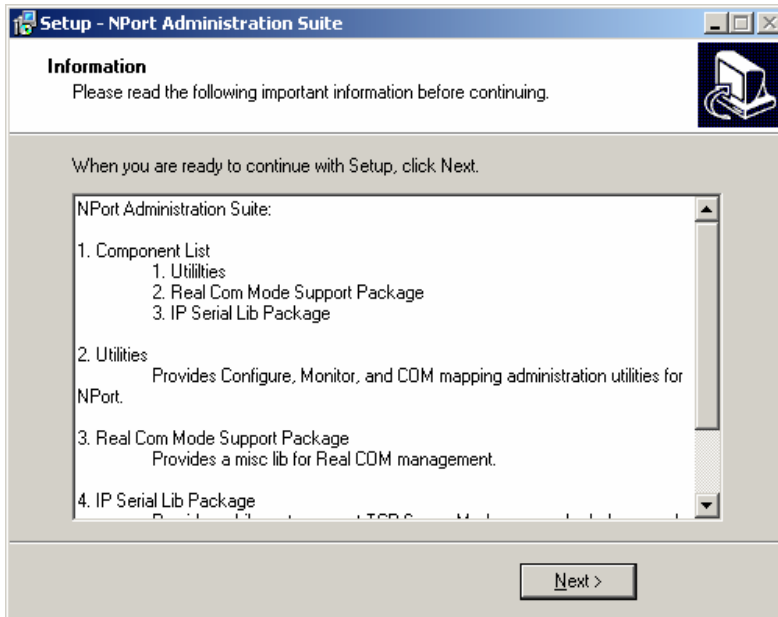

- 7. Click **Finish** to complete the installation of the NPort Administration Suite.

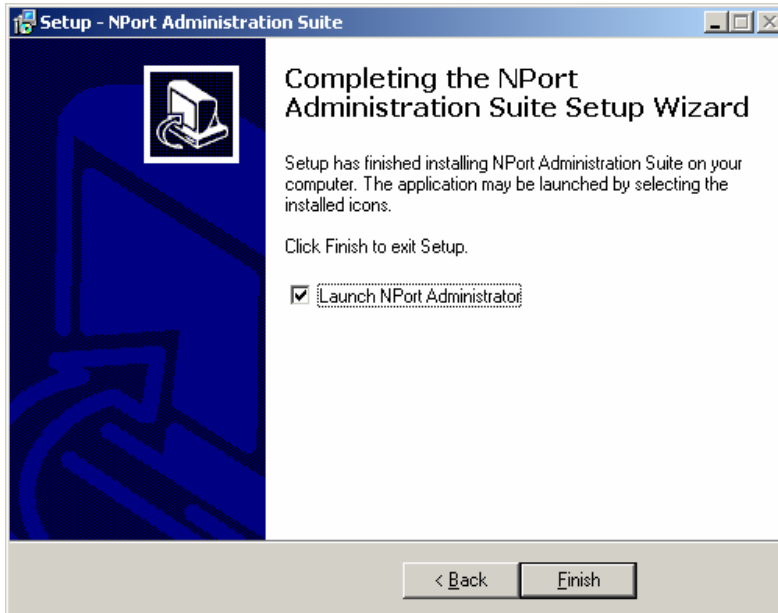

# Basic Navigation

## Window Layout

NPort Administrator is designed to make it easy to configure, monitor, or manage any NPort 5600-8-DT/DTL on your network. The interface is organized into four areas as follows:

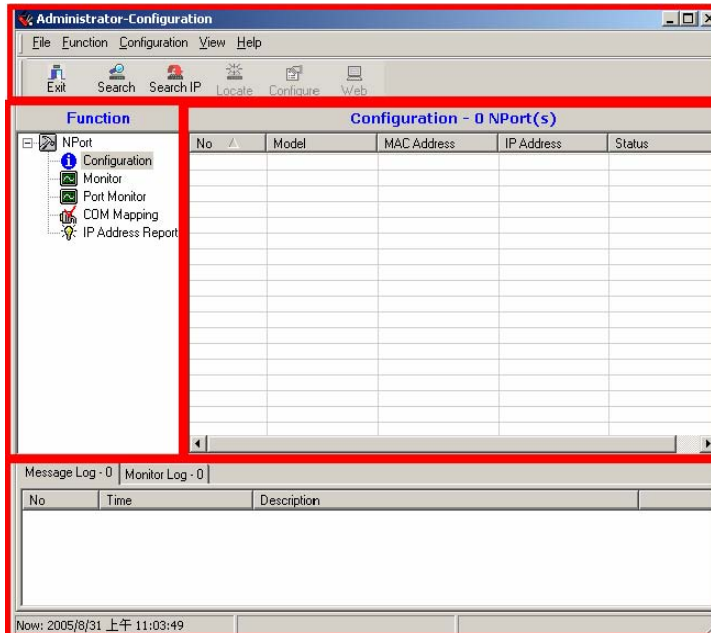

- The top section is the menu area.
- The left panel is the Function panel. This is where you navigate between different functions. You may also use the Function menu on the menu bar.
- The right panel is the list of device servers that are available for the selected function. A target device server must be selected from this list in order to activate specific commands. First right-click the target unit to bring up a function context menu, then select the desired command from the menu.
- The bottom section is the log area, which shows a record of status and processing messages.

## Activating a Function

All functions in NPort Administrator are activated by first selecting the function, then selecting the target device server, and finally selecting the specific command:

1. Select the desired function in the Function panel.

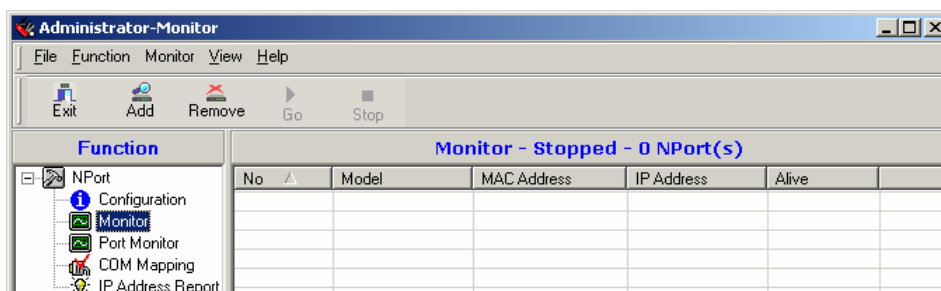

2. If your device server is already listed in the right panel, you may skip to the next step. If the list of device servers is empty, you will need to "find" your device server. Right-click the desired function in the function panel to open the function context menu. You will need to add device servers to the list by selecting a command such as "Search" or "Add Target".

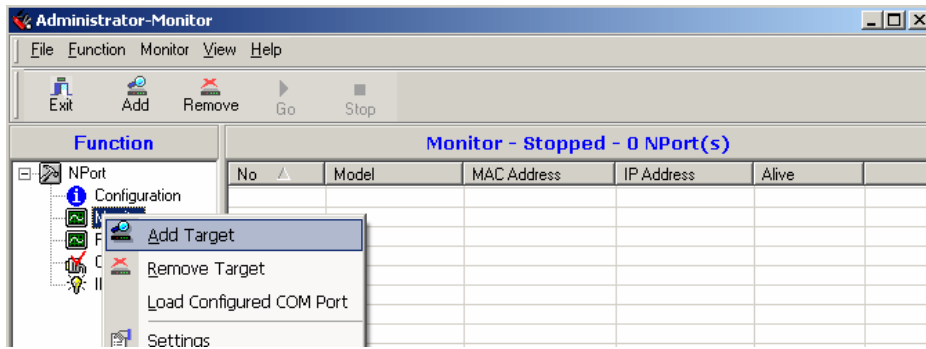

- Once your device server is on the list for the desired function, right-click the target device server to open the function context menu. Activate the desired command from this context menu. You may also select the target device server and then open the function context menu from the menu bar.

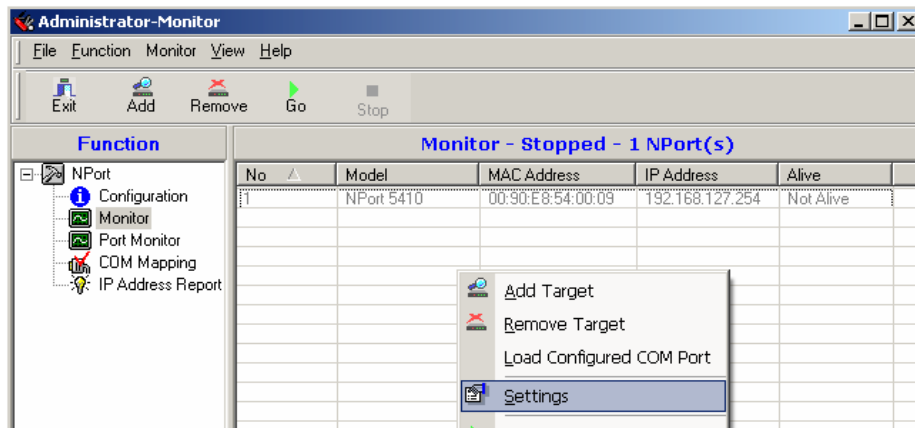

## Configuration

Select the Configuration function to configure your NPort, import and export its configuration, or update its firmware.

## Finding Your Device Server

If the list of available servers is empty, find your device server on the network using the Broadcast Search or Specify by IP Address commands in the function context menu.

**Broadcast Search:** This searches for all NPort units on the LAN. Since this search is based on MAC address, rather than IP address, it will be able to find units that are not on the same subnet as your PC. You may click **Stop** as soon as your device server is found.

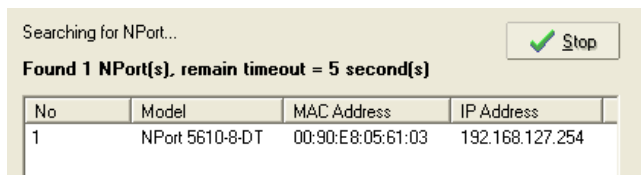

**Specify by IP Address:** This allows you to find your device server manually by entering its IP address.

## Status

The NPort may be password-protected to prevent unauthorized configuration changes. Please refer to Chapter 4 for additional information on password protection. The status will be shown in the list of available device servers. There are six possible statuses for device servers on the network.

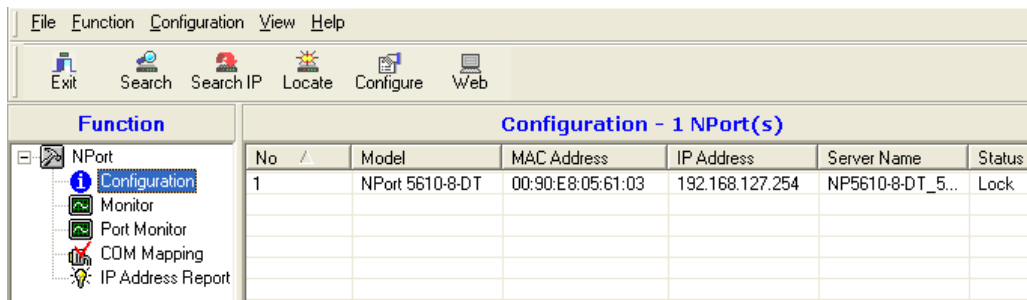

Status	Description
Lock	The unit was located by broadcast search. It is password-protected, and the correct password has not been provided during this session.
Unlock	The unit was located by broadcast search. Password protection has not been set up for the unit.
(blank)	The unit was located by broadcast search. Password protection has not been set up for the unit.
Fixed	The unit was manually located by "Search IP" and has no password protection.
Lock Fixed	The unit was manually located by "Search IP". It is password protected, and the current password has not been provided during this session.
Unlock Fixed	The unit was manually located by "Search IP". It was password-protected, but the correct password has been provided for this session.

If you wish to configure a unit that is Locked or Lock Fixed, you will need to unlock the unit first as described below:

1. Select the Unlock command in the function context menu for the target device server.

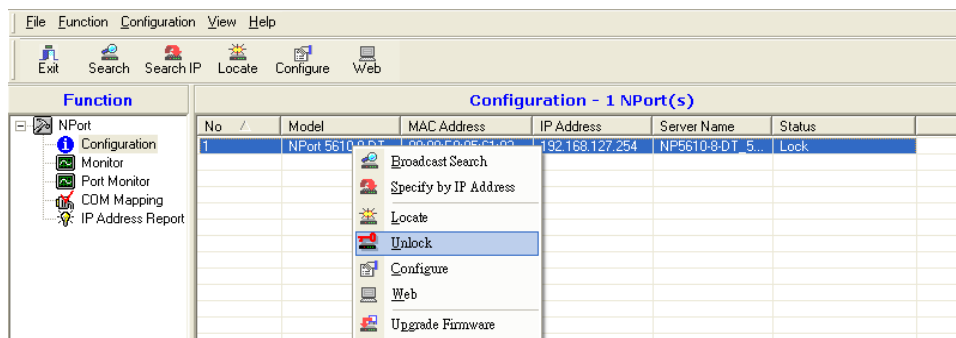

2. Enter the password and click **OK**.

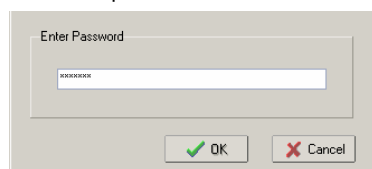

3. If the correct password is provided, you will receive an "Unlock ok" message.

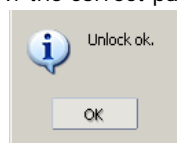

4. The device server's status will be updated to "Unlock".

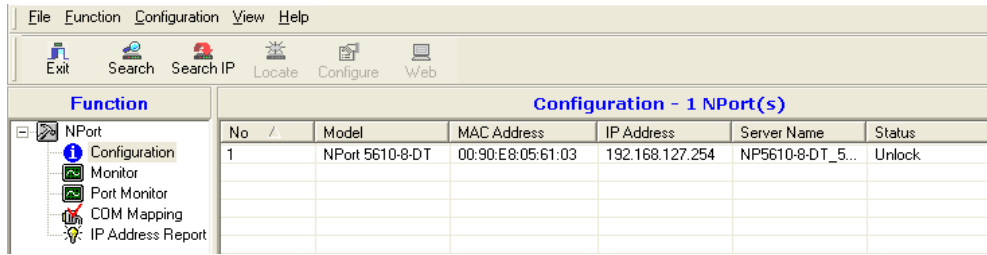

## Device Server Parameters

You can configure any NPort 5600-8-DT/DTL on the LAN using the Assign IP Address, Configure, or Web commands in the function context menu.

**Assign IP Address:** This allows you to set the target NPort's IP address quickly, instead of digging through pages of configuration parameters.

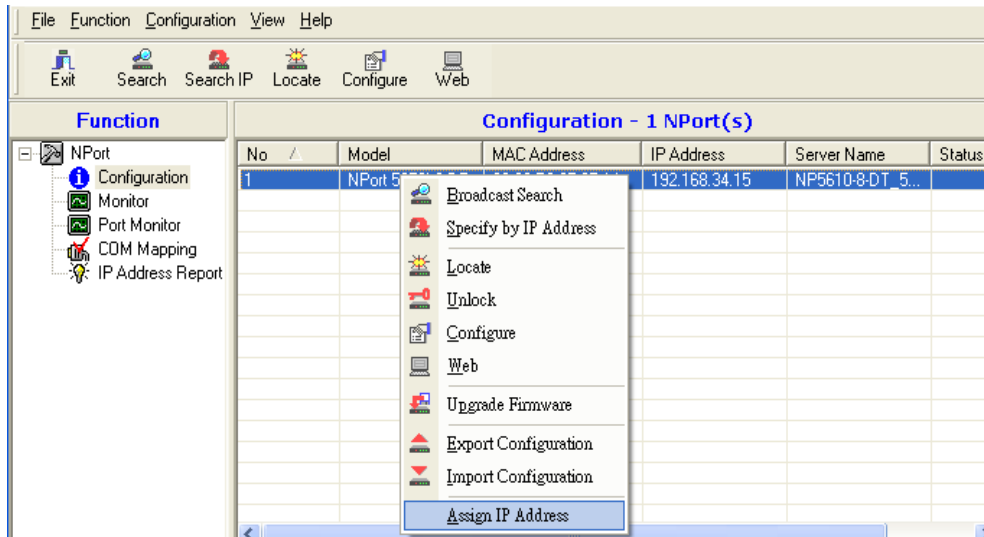

**Configure:** This opens the target device server's configuration window.

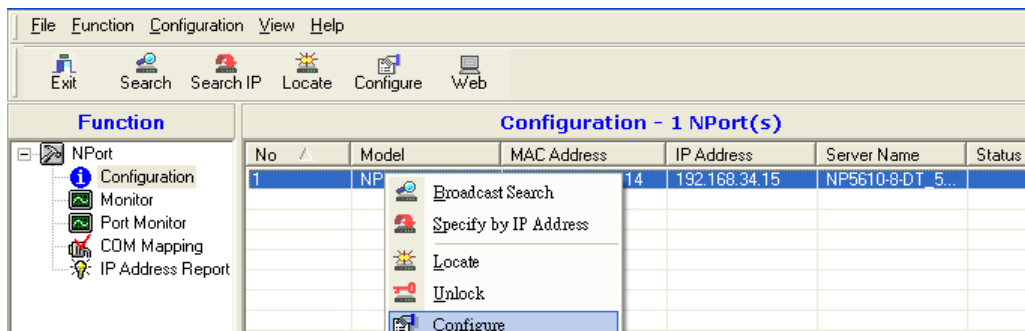

Parameters are grouped into tabs. Please refer to Chapter 4 for a description of all general settings for the NPort 5600-8-DT/DTL. Click a **Modify** checkbox to enable changes to the associated parameter. Click **OK** to implement changes.

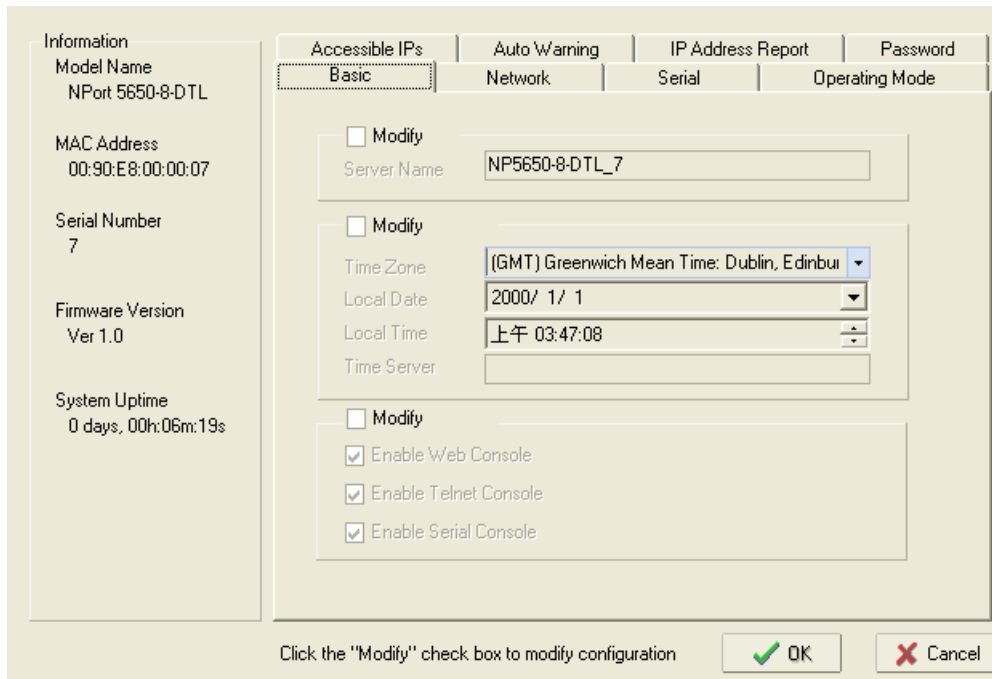

**ATTENTION**

You can configure multiple units simultaneously, as long as the units are the same model. Simply hold down the Ctrl or Shift key when selecting the target device servers.

**Web:** This opens the target device server’s web console. Please refer to Chapter 7 for details on using the web console.

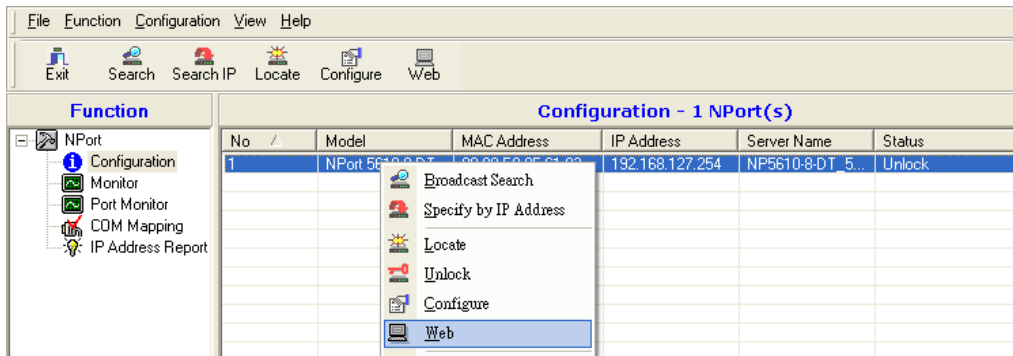

## Firmware and Configuration Management

You can manage your device servers' firmware and configuration using the Upgrade Firmware and Import/Export Configuration commands.

**Upgrade Firmware:** This allows you to upload new firmware to the target NPort device server. You can obtain firmware updates for your NPort 5600-8-DT/DTL at [www.moxa.com](http://www.moxa.com).

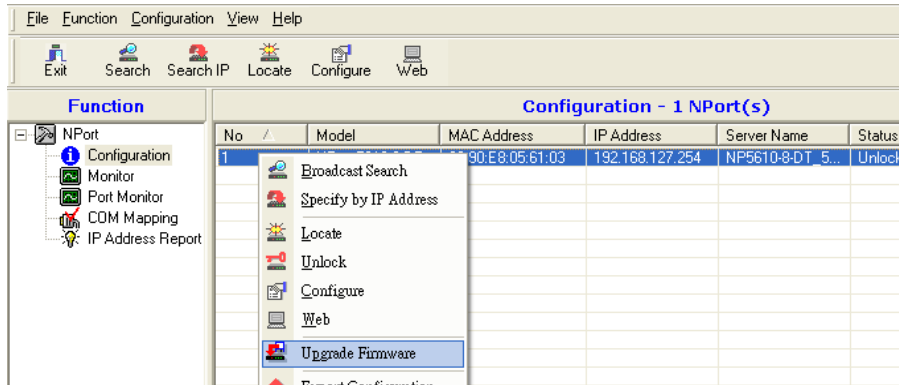

Browse for the new firmware file and click **OK**.

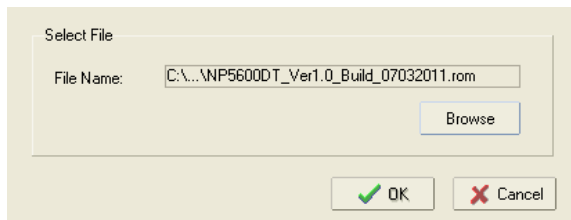

It will take a few moments for the NPort's firmware to be updated. Do not disconnect the network, the NPort, or your PC at any time during the update.

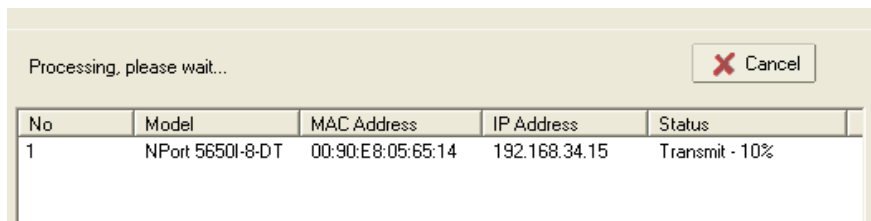

### ATTENTION

You can update the firmware of multiple units simultaneously, as long as the units are the same model. Simply hold down the Ctrl or Shift key when selecting the target device servers.

**Import/Export Configuration:** These commands are used to save or restore the target device server's configuration. All configuration settings can be stored on a file to be restored later, from anywhere on the network.



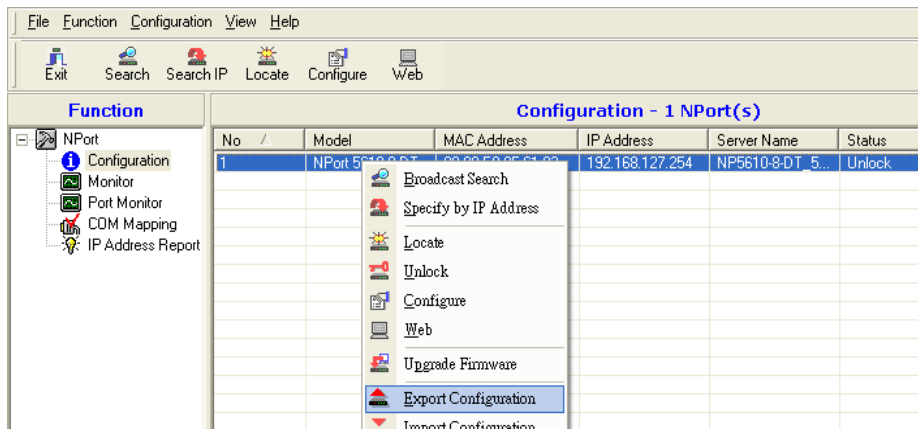

Follow the onscreen instructions to save or restore the target unit’s configuration.



**ATTENTION**

You can import the configuration of multiple units simultaneously, as long as the units are the same model. Simply hold down the Ctrl or Shift key when selecting the target device servers.

## Monitor

You can use NPort Administrator for live monitoring of your NPort over the network. Different parameters and events may be monitored, and you can receive pop-up warnings for certain events.

## Finding Your Device Server

If the list of available servers is empty, find your device server on the network using the Add Target or Load Configured COM Port commands in the function context menu.

**Add Target:** This selects NPort device servers on the LAN for monitoring. You may need to click “Rescan” to search the network again for NPort device servers. Once a device server has been found, select it in order to add it to the Monitor list. You can also select “Input manually” to enter a specific IP address and model for monitoring.

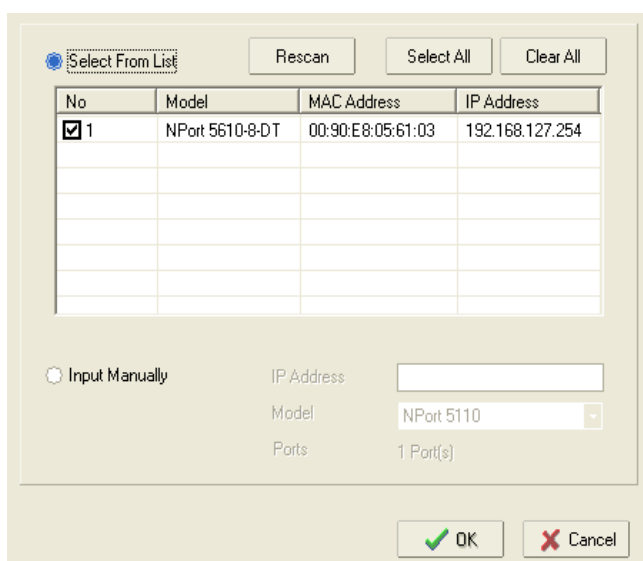

**Remove Target:** This removes a device server from the monitor list.

**Load Configured COM Port:** If COM ports have been mapped to NPort device servers, this command automatically adds those device servers to the monitor list.

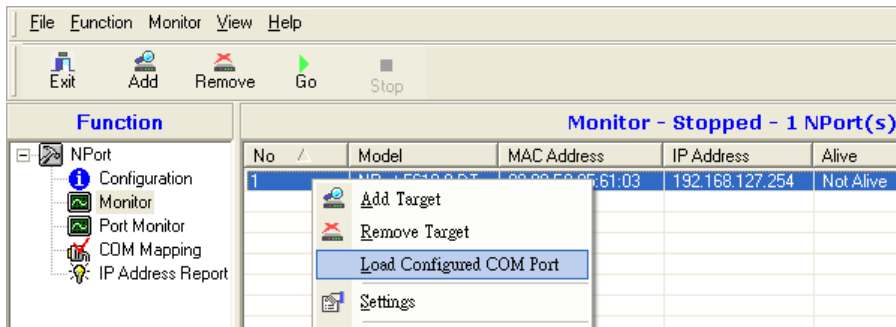

## Monitoring Parameters

The **Settings** command specifies which items of information will be monitored, how often the information is refreshed, and how notification of events will occur.

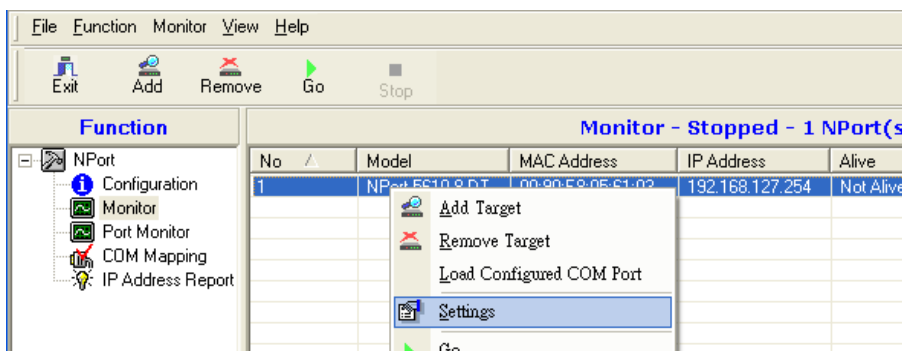

In the **Monitor Items** tab, you may select which items of information will be monitored.

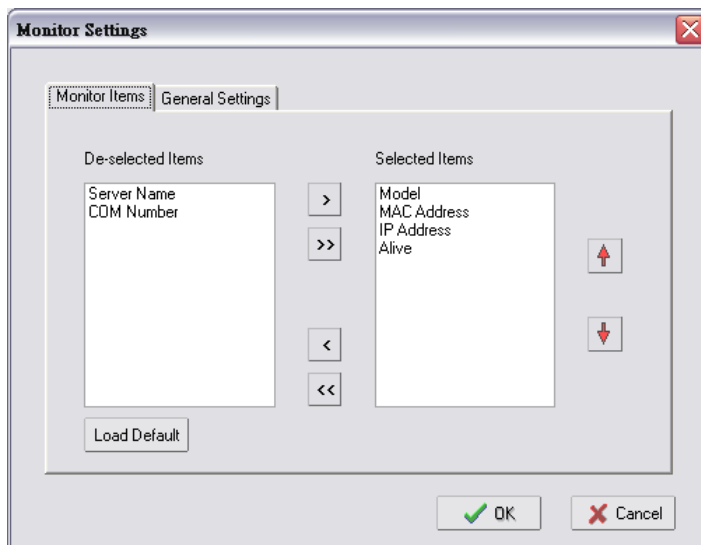

In the **General Settings** tab, you may select the monitoring refresh rate, which is how often the monitor function will check the status of each NPort on the monitor list. The default is 3 seconds.

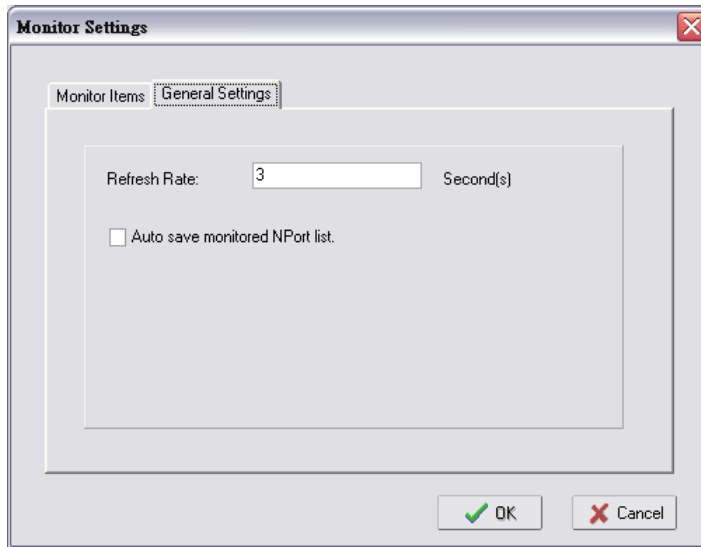

## Activating the Monitor

The **Go** command activates live monitoring.

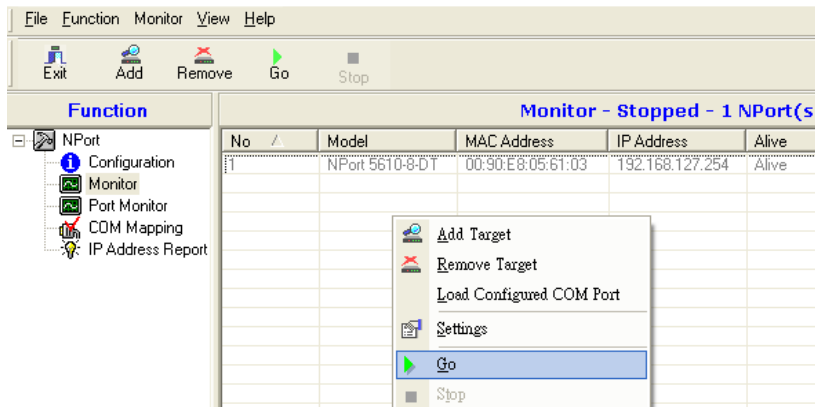

The monitor list will now be monitored live, as indicated by “Running” in the header.

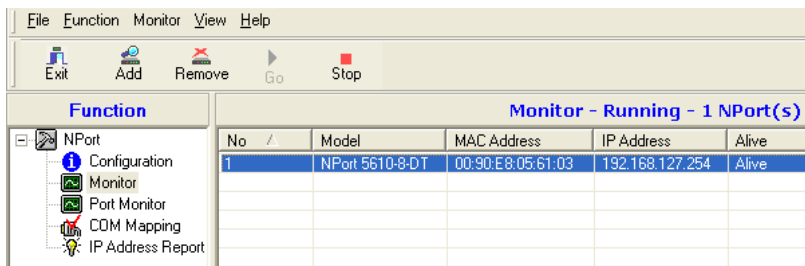

If you configured the monitor function with warnings enabled, a notification will appear if a monitored device server goes off-line.

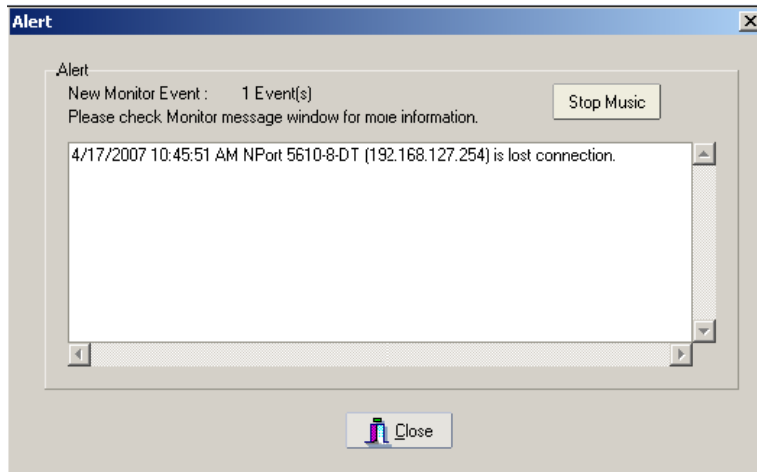

NPorts that are off-line will be also displayed in red in the monitor list.

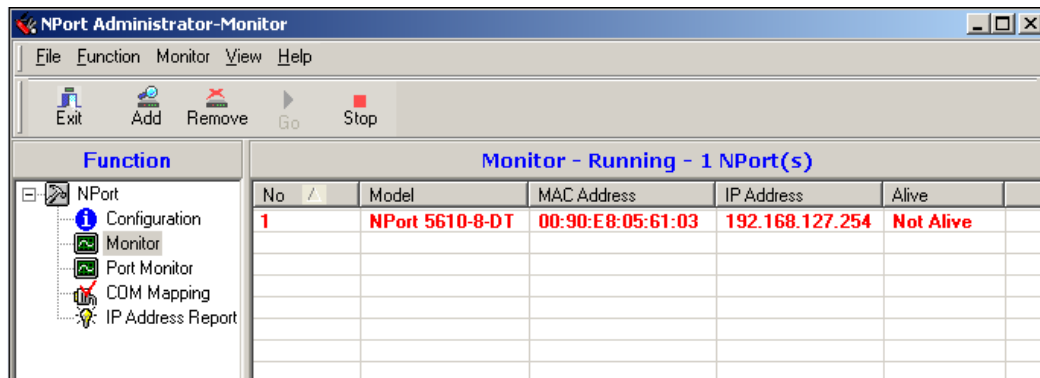

If the NPort is able to re-establish the connection, another notification will appear indicating that the NPort 5600-8-DT/DTL is now "Alive." The monitor list will be updated accordingly.

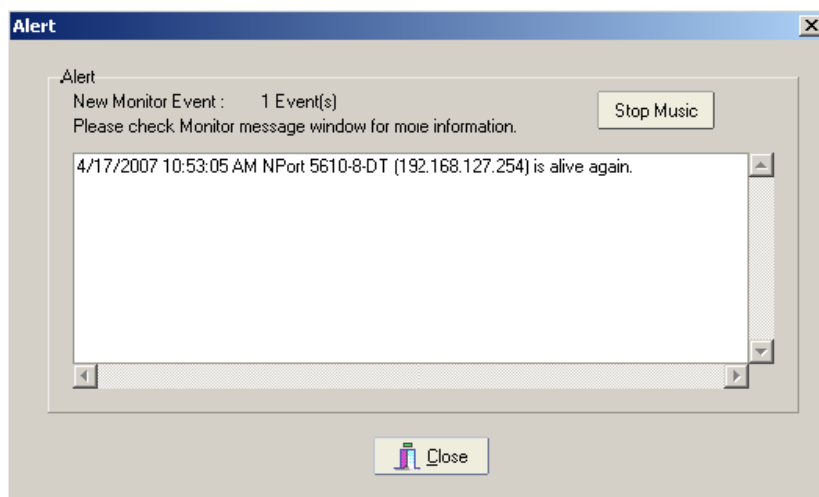

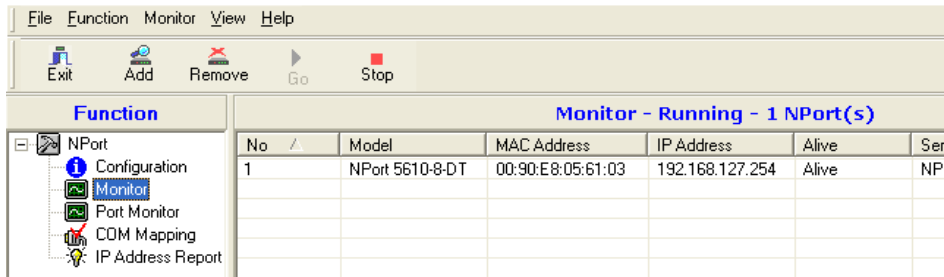

Select the **Stop** command to suspend live monitoring.

## Port Monitor

The **Port Monitor** function is identical to the **Monitor** function, but with many additional items that can be monitored, as shown below.

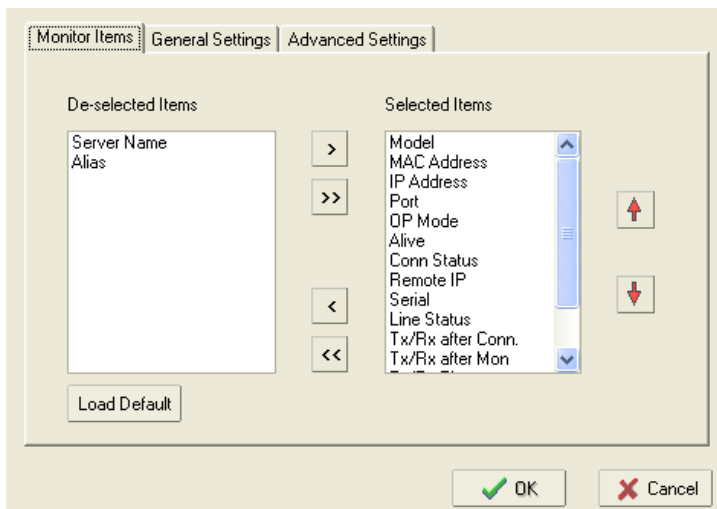

In addition, each item on the port monitor list will be an individual device port on an NPort device server. Each device port can be selected or deselected for monitoring.

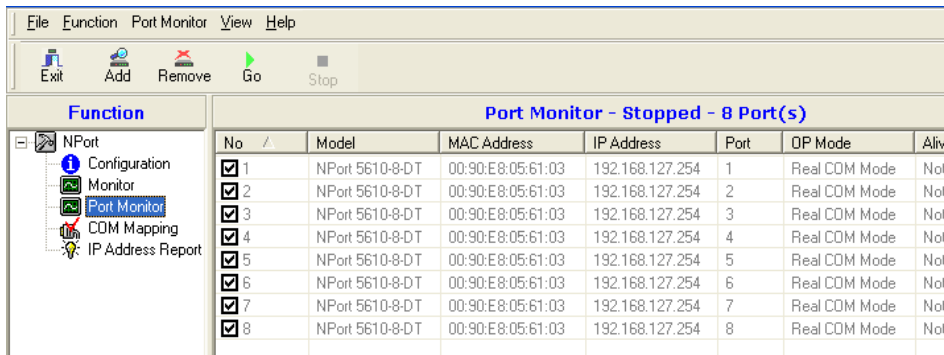

## COM Mapping

The NPort Administrator Suite is installed with Real COM drivers that work with Windows 95 and above. These drivers transparently connect a COM port on the PC to a device port on the NPort device server. This allows a local application to use COM5, for example, to communicate with a device attached to the NPort. Use the COM Mapping function to define the mapping assignments.



**ATTENTION**

A device port must be operating in Real COM mode in order to be used in COM mapping.

## Finding Your Device Server

If the list of available servers is empty, find your device server on the network using the **Add Target** command in the function context menu.

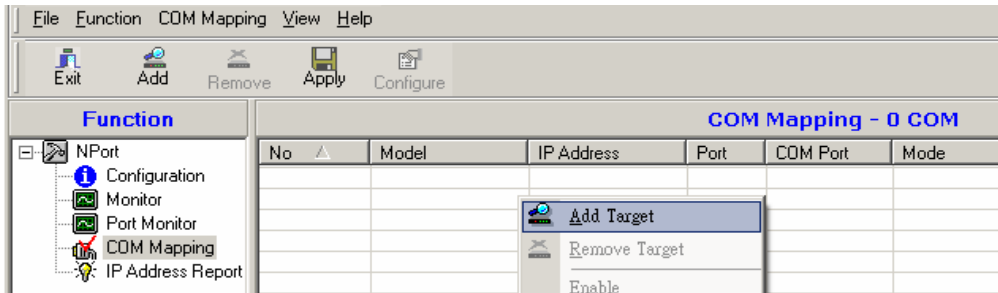

You may need to click “Rescan” to search the network again for NPort device servers. Once your device server has been found, select it in order to add it to the COM mapping list. You can also select “Input manually” to enter a specific IP address and model.

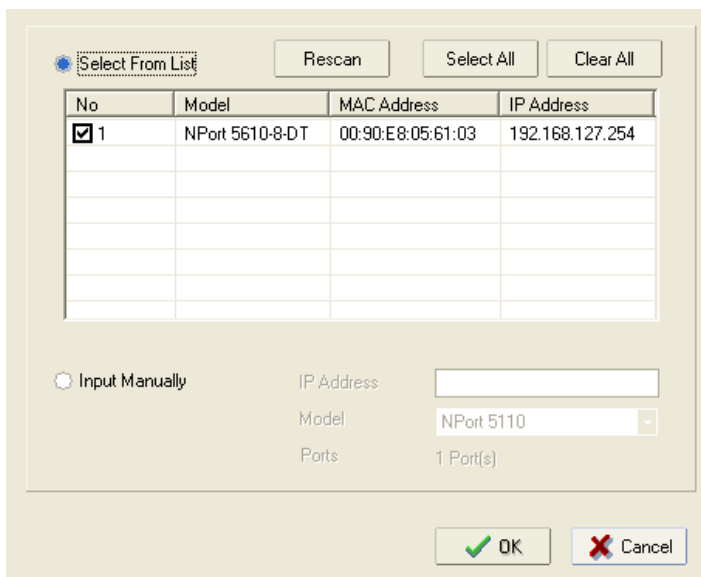

To remove a device server from the COM mapping list, use the **Remove Target** command in the function context menu.



**ATTENTION**

You can configure COM mapping even if your device server is off-line (not connected). When using the Add Target command, simply select the “Input manually” option and enter the IP address and model. This is a useful option for certain field installations where COM mapping must be set up before the NPort is physically installed.

## COM Mapping Settings

Each item on the COM mapping list refers to an individual device port on an NPort device server. To map a COM port to a listed device port, right-click the target device port and select **COM Settings** in the function context menu.

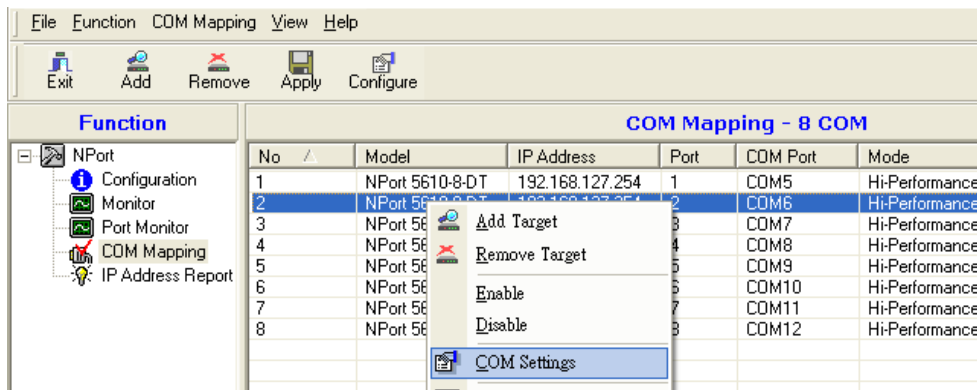

### ATTENTION

You can map multiple COM ports in one step by holding down the Ctrl or Shift key when selecting the target device ports.

In the **Basic Settings** tab, the COM Number parameter selects the COM port that will be mapped to the device port. The drop-down list shows available COM ports with status.

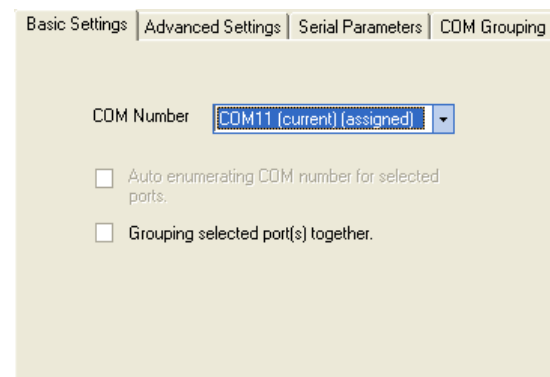
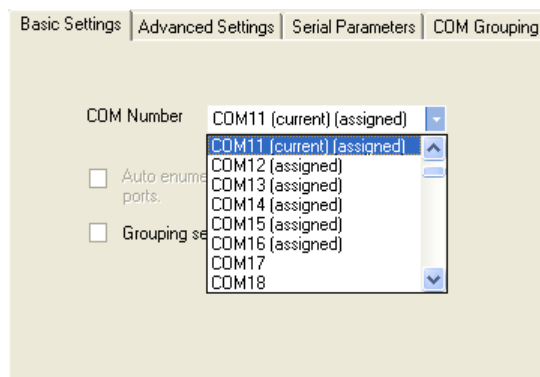

Status	Description
in use	Already being used by system or already mapped to an NPort device port
assigned	Assigned to an NPort device port but changes have not been applied yet
current	Assigned to currently selected device port, changes have not been applied yet

The “Auto Enumerating” parameter can be used when mapping multiple device ports at the same time. When the parameter is checked, this option automatically assigns available COM numbers sequentially. If not checked, you will need to configure COM mapping for each device port separately.

In the **Advanced Settings** tab, you may configure how serial data is transmitted from the PC to the NPort device port.

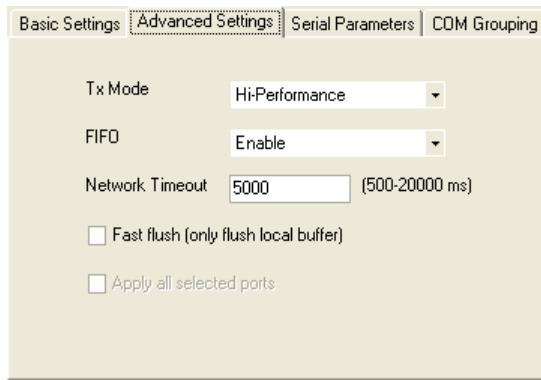

**Tx Mode**  
Hi-Performance is the default for Tx mode. After the driver sends data to the NPort, the driver immediately issues a “Tx Empty” response to the program. Under Classical mode, the driver will not send the “Tx Empty” response until after confirmation is received from the NPort. This causes lower throughput. Classical mode is recommended if you want to ensure that all data is sent out before further processing.

**FIFO**  
When “FIFO” is disabled, the selected device port will send one byte each time the Tx FIFO becomes empty, and an Rx interrupt will be generated for each incoming byte. This will cause a faster response time but lower throughput.

**Network Timeout**  
“Network Timeout” specifies how long the driver will wait for the attached serial device to respond to an open, close or serial parameter change operation. If a response is received by the specified time, the operation will time out. The default value is 5000 milliseconds.

**Fast Flush**  
“Fast Flush” is designed to improve response times for applications that use the Win32 PurgeComm() function. When Fast Flush is enabled, the Real COM driver only flushes the local buffer on the host when it receives the PurgeComm() function call. When disabled, applications that use PurgeComm() may perform markedly slower, because the Real COM driver will need to also flush the remote buffer, which requires repeated queries of the NPort to make sure no data is queued in the remote buffer. The repeated queries can cause a performance hit due to the additional time spent communicating over the network, typically about several hundred milliseconds when compared to COM ports. If your application uses PurgeComm() and performance seems sluggish, try enabling Fast Flush.

In the **Serial Parameters** tab, the COM port’s serial communication parameters are defined.

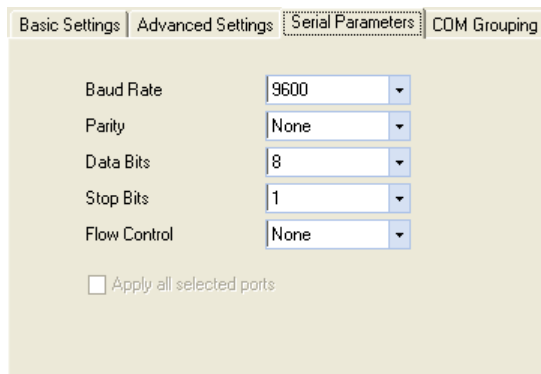



## Saving COM Mapping Settings

After mapping COM ports to NPort device ports, you will need to save the COM mapping settings to the Real COM driver. Use the **Apply Change** command in the function context menu to save the mapping settings; use the **Discard Change** command to delete the changes. Once COM mapping has been applied, the Real COM driver will transparently connect the designated COM port to the device port. NPort Administrator is not needed for Real COM operation. COM mapping will be effective whether or not NPort Administrator is open.

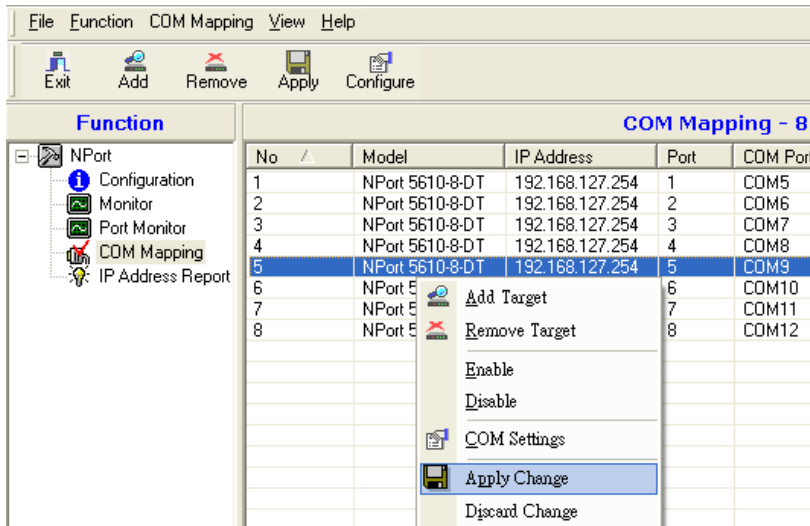

You can also save COM mapping settings to a text file, which can then be used to duplicate the COM mapping on another host. Use the **Export COM Mapping** command in the function context menu to save the current COM mapping settings. Use the **Import COM Mapping** command to load COM mapping settings from a previously saved file.

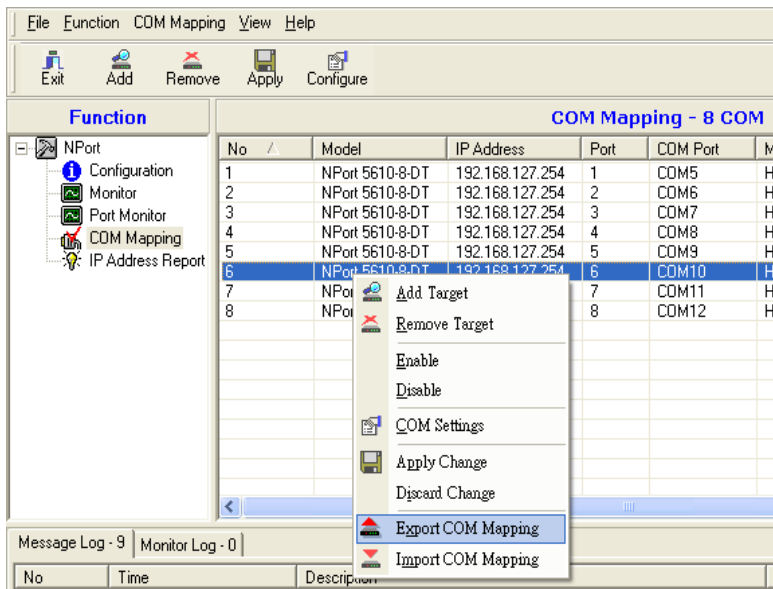

# COM Grouping

The “COM Grouping” function is designed to simulate the multi-drop behavior of serial communication over an Ethernet network. COM Grouping allows you to create a COM Group and redirect data from it to several physical COM ports on NPort device servers. With COM Grouping, you will be able to control multiple physical serial ports simultaneously by operating only one COM port.

## Creating a COM Group

Follow the steps below to add multiple COM ports into one group:

1. Select serial port(s) for the group that you are going to create, and right-click to select **COM Settings**.

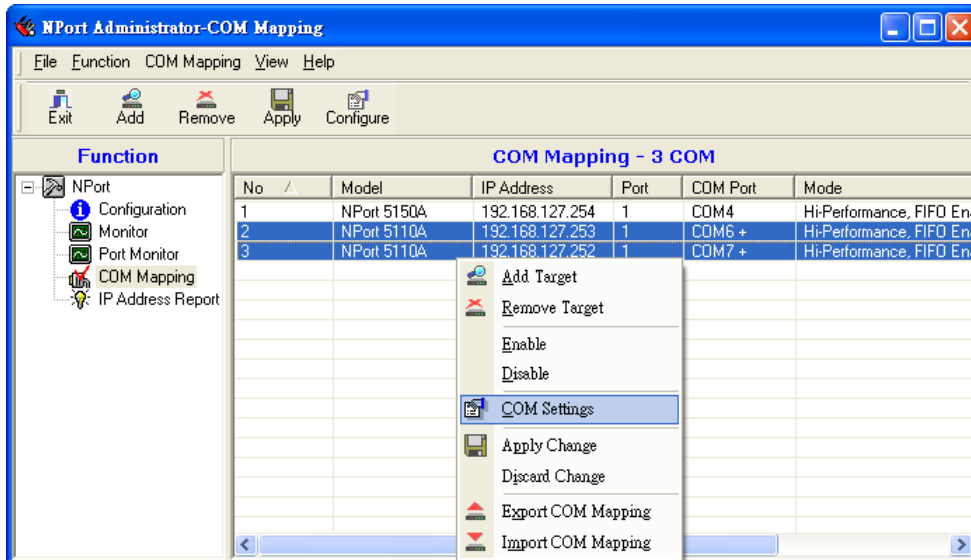

2. Select a COM number for this COM group. You may select one of the ports already assigned to a member of the COM Group. However, once the COM Group is configured, all of the original COM number(s) within the group will be released simultaneously.

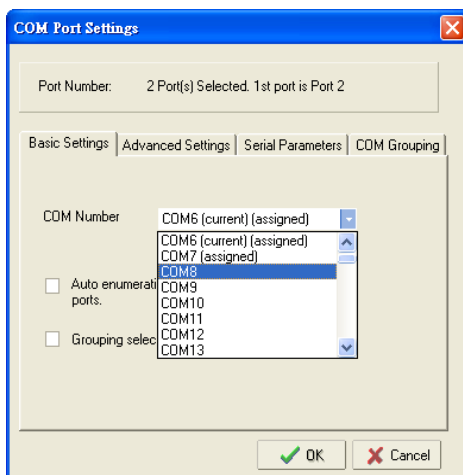

### ATTENTION

The COM Grouping function only supports Windows NT, 2000, and later. The maximum number of ports for each group is 32.

3. Select the **Grouping selected port(s) together** checkbox.

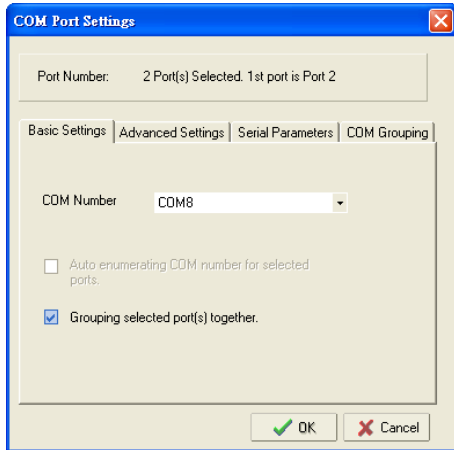

4. On the **COM Grouping** page, you can set "Read" and "Write" permissions for every serial port. It is necessary to set **Signal Status** in order to control the data transmission with specified control signals (e.g., DTR/RTS). You can assign one serial port whose signals will be taken into account by the COM Group.

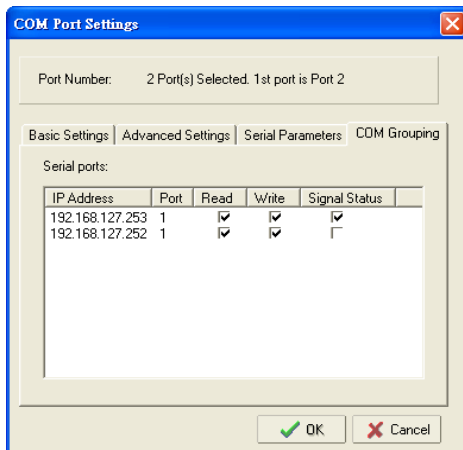

5. Click OK, and confirm that the serial ports that were assigned. The COM Port column confirms that your selected ports are labeled as part of a "Group." You will be able to view the serial ports that were assigned to and removed from the Group. Click **Apply** to apply the settings.

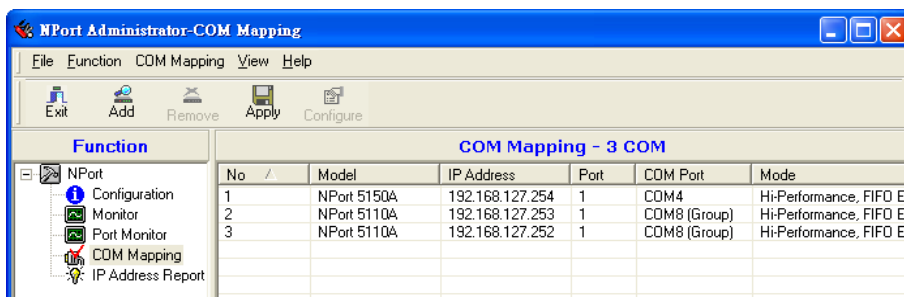

6. Finally, click Yes to confirm.

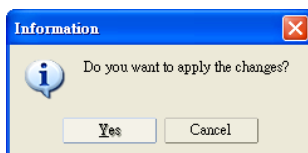

## Deleting a COM Group

Follow the steps below to delete a COM Group and then auto-assign COM numbers for each port in the Group:

1. Select all serial ports in the Group you are deleting and then right-click to select **COM Settings**.

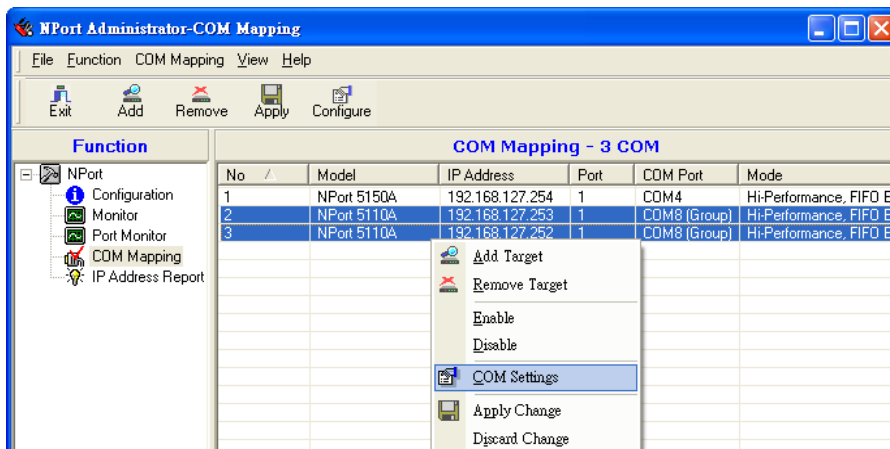

2. Select a COM number for this COM group and check the **Auto enumerating COM number for selected ports** to use the COM number you select as the first starting COM number, and then click OK.

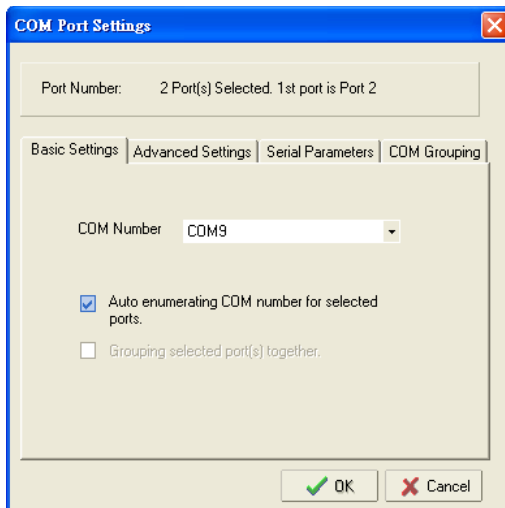

3. You will be able to view the serial ports that were assigned to and removed from the Group. Click **Apply** to apply the settings.

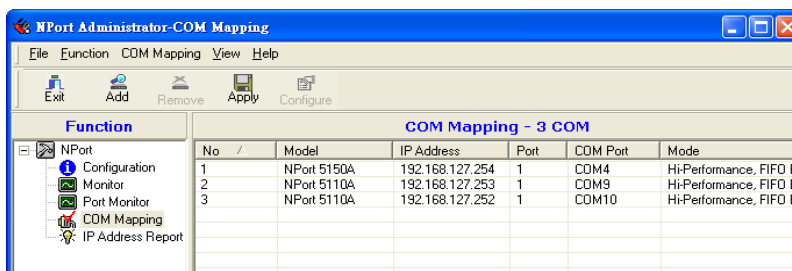

4. Finally, click Yes to confirm.

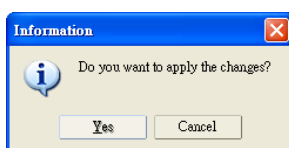

## Adding a Port to a COM Group

Follow the steps below to add a serial port into an existing COM Group:

1. Select the serial port that you are adding and right-click to select **COM Settings**.

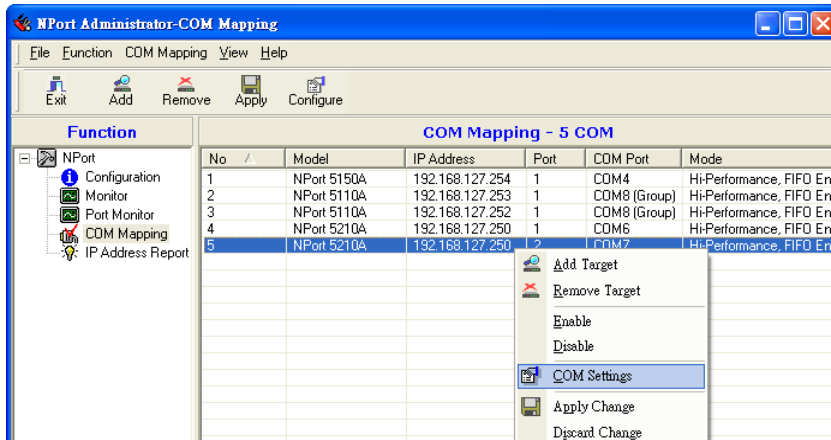

2. Select the COM number of the COM Group you are adding and check mark the **Grouping selected port(s) together** check box and then click OK.

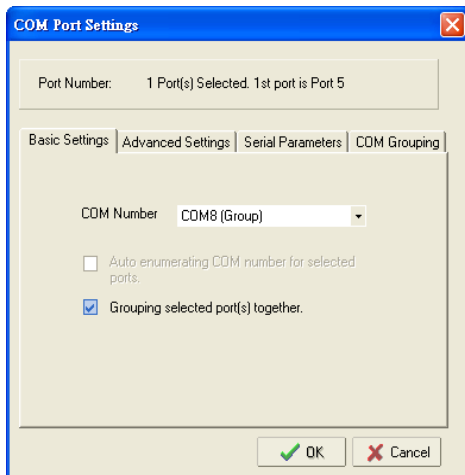

You will be able to view the serial ports that were assigned to and removed from the Group. Click **Apply** to apply the settings.

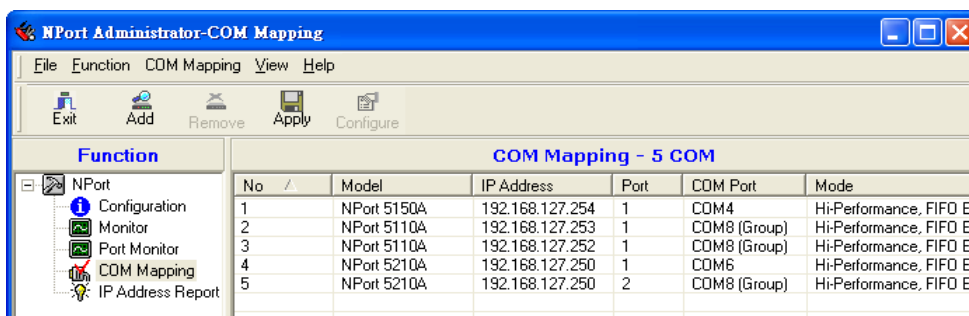

3. Finally, click Yes to confirm.

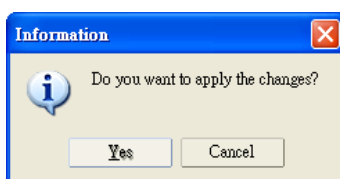

## Removing a Port from a COM Group

Follow the steps below to remove a serial port from a COM Group:

1. Select a serial port in the Group and right-click to select **COM Settings**.

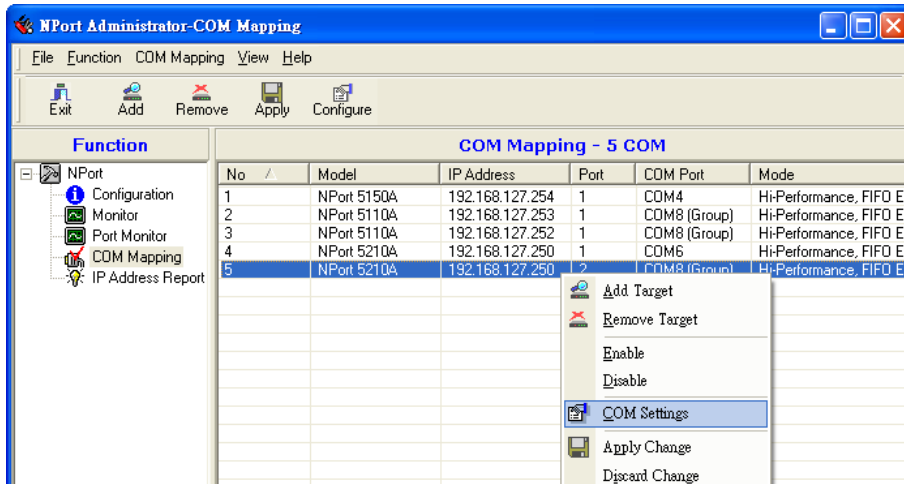

2. Select a COM number that is not in use or assigned to a Group and click OK.

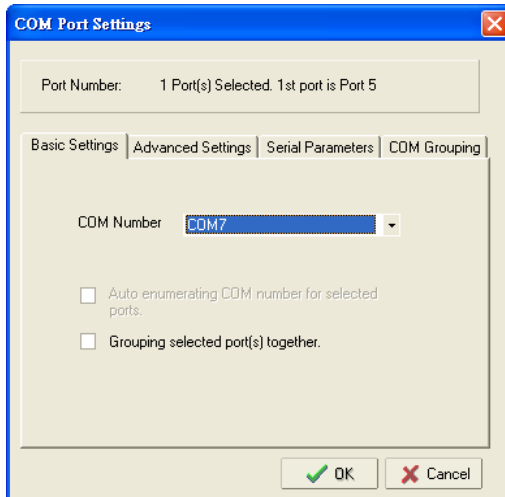

3. You will be able to view the serial ports that were assigned to and removed from the Group. Click **Apply** to apply the settings.

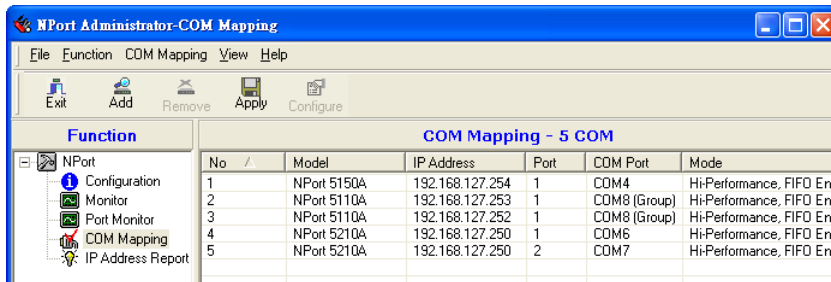

4. Finally, click Yes to confirm.

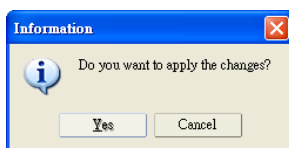

## Modifying Ports in a COM Group

In the following subsections we examine three ways in which the serial ports in a COM Group can be modified:

### Changing the COM Number of a COM Group

1. Select all serial ports in the Group and right-click to select **COM Settings**.

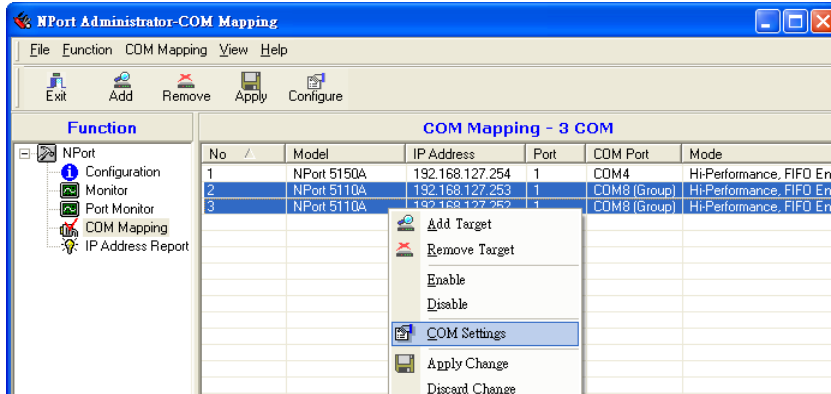

2. Select a COM number that is not in use or assigned to a Group.

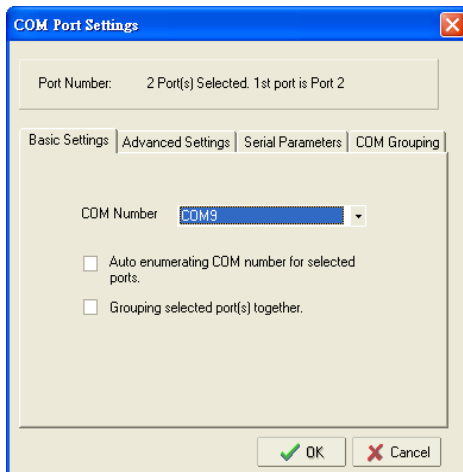

3. Select the **Grouping selected port(s) together** checkbox and then click **OK**.

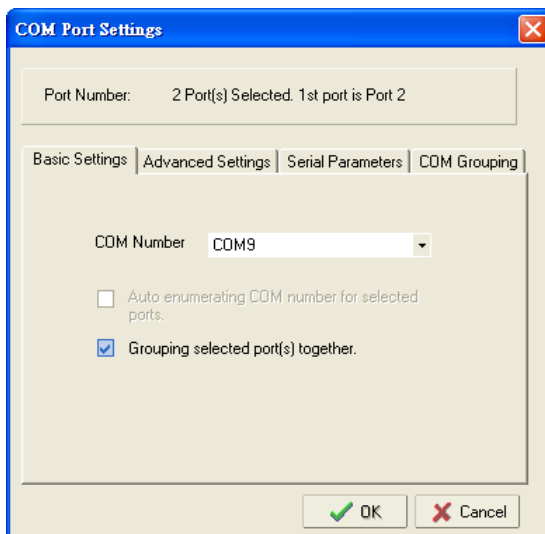

- You will be able to view the serial ports that were assigned to and removed from the Group. Click **Apply** to apply the settings.

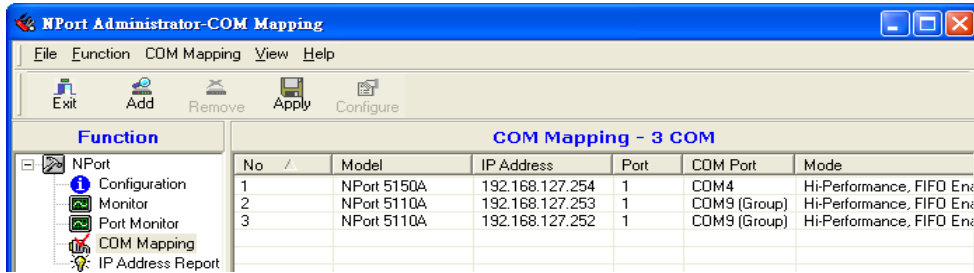

- Finally, click Yes to confirm.

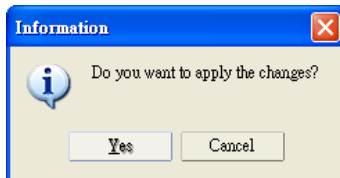

## Changing Advanced Settings and Serial Parameters of the COM Group

- Check the port specified on the **COM Grouping** page as the signal port.

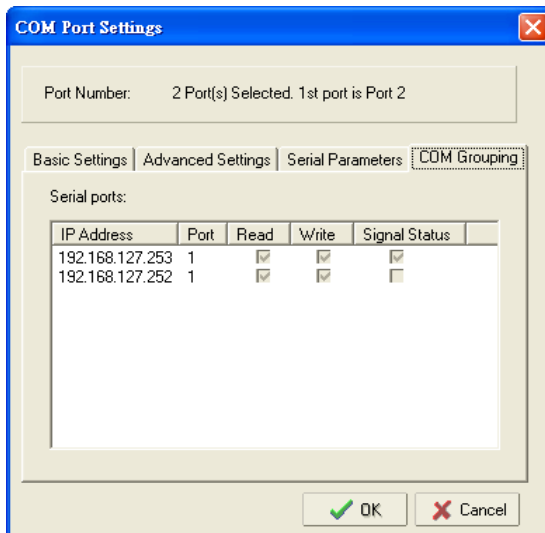

- Select the "Signal Status" controlled port and then right-click and select **COM Settings**.

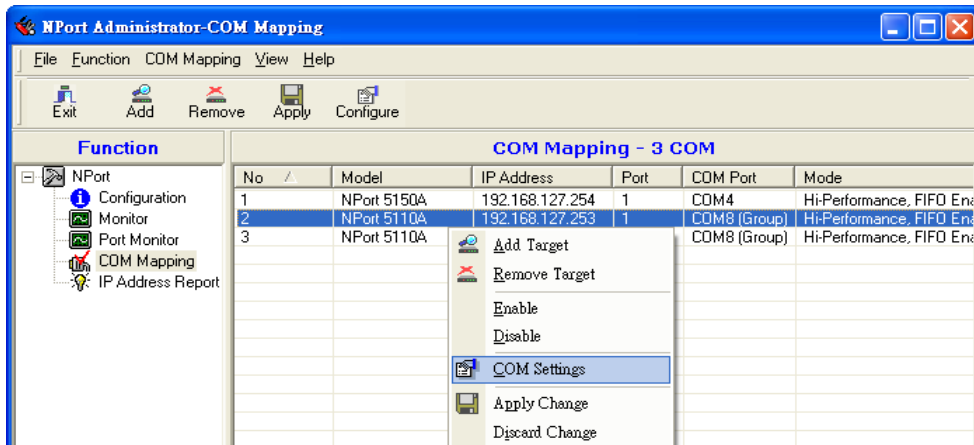



- The **Advanced Settings** and **Serial Parameters** pages will be available for modification.

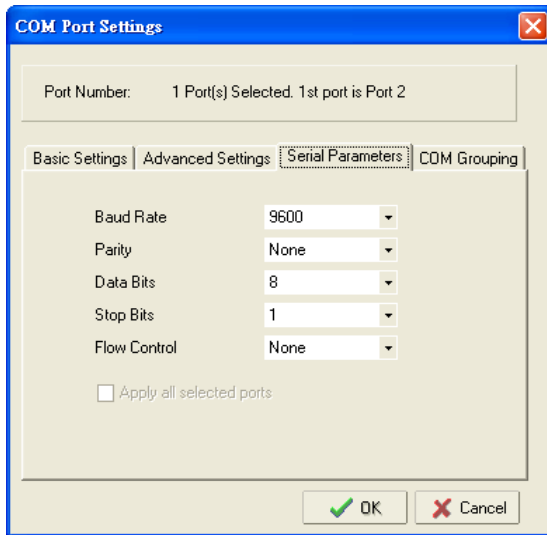
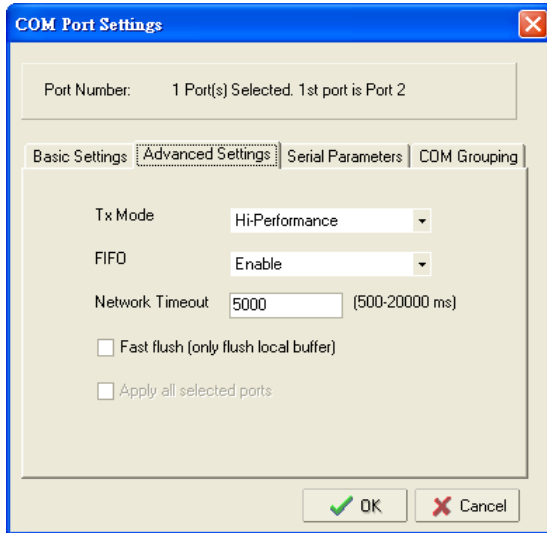

### Changing the Serial Port Specified as Signal Port for the COM Group

- Select a serial port in the Group and then right-click and select **COM Settings**.

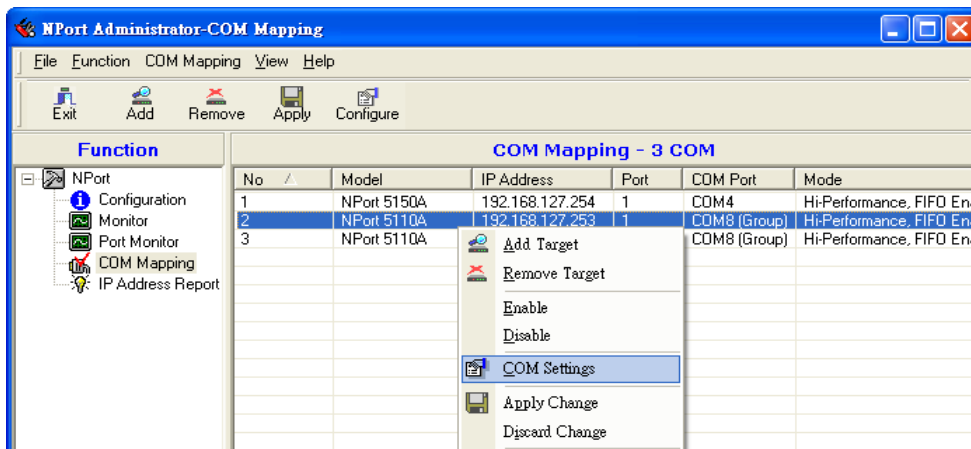

2. Check the **Grouping selected port(s) together** check box.

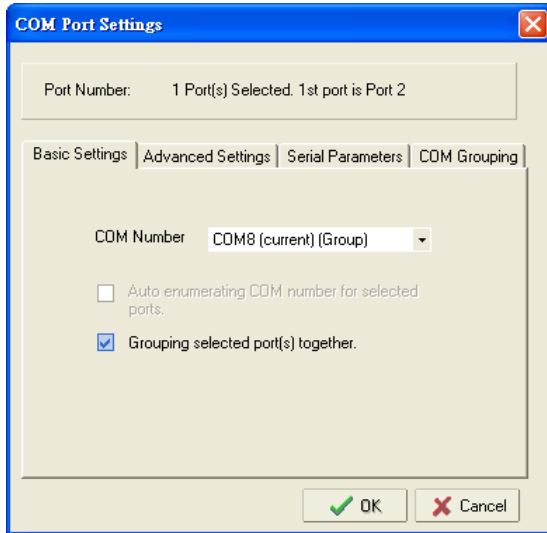

3. On **COM Grouping** page, you can specify one serial port whose signals will be taken into account by the COM Group and change the Read/Write status for each serial port.

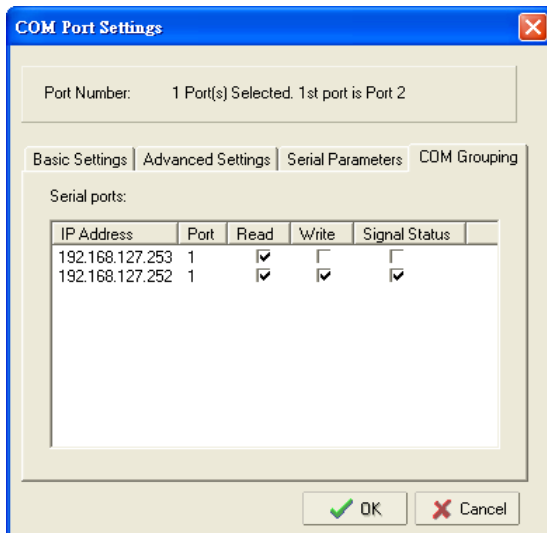

## IP Address Report

The **IP Address Report** function receives automatic IP reports from appropriately configured NPort device servers. Use the **Settings** command in the function context menu to designate the UDP port number that the NPort will use when sending IP address reports. This must correspond with the network settings on the NPort device server.

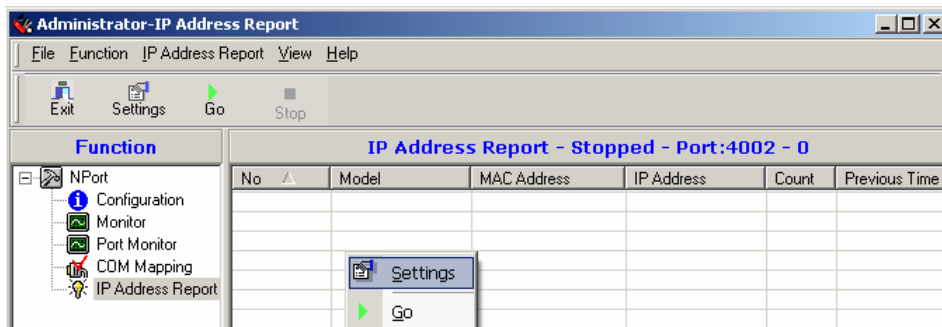

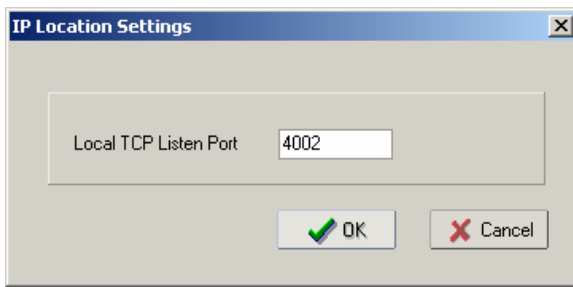

On the NPort device server, the **Auto report to IP** parameter must be set to the IP address of the PC that is running NPort Administrator.



Select **Go** from the function context menu to begin monitoring for IP address reports. The IP Address Report window will begin displaying IP reports as they are received. Select **Stop** from the context menu to suspend monitoring, and **Clear** to clear the current display of reports.

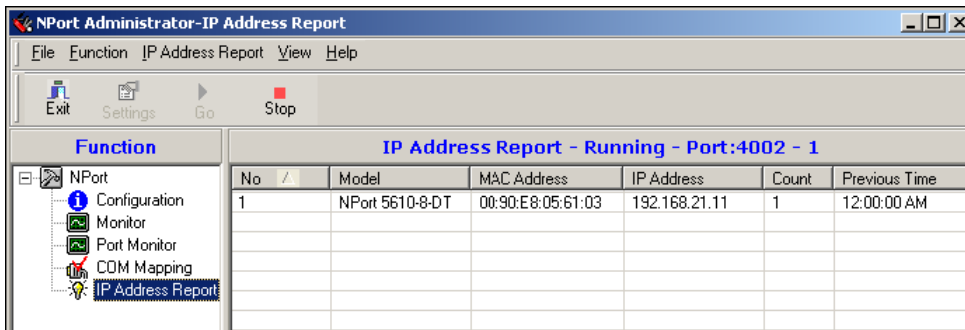

Please refer to Chapter 4 for information on configuring the NPort to send automatic IP reports. Please refer to Appendix C for information on the IP report protocol.

## Automatic Message Log

When NPort Administrator is closed, all activity in that session is saved in a log file in the installation directory. Log files are generated in sequence, starting with **file message\_0.log**. After **file message\_9.log**, the next log file will start over again at **file message\_0.log**.

# **NPort CE Driver Manager for Windows CE**

---

The following topics are covered in this chapter:

- **Overview**
- **Installing NPort CE Driver Manager**
- **Using NPort CE Driver Manager**

## Overview

NPort CE Driver Manager is designed for use with NPort 5000 serial ports that are set to Real COM mode. The software manages the installation of drivers that allow you to map unused COM ports on your PC to serial ports on the NPort 5000. These drivers are designed for use with Windows CE 5.0/6.0. When the drivers are installed and configured, devices that are attached to serial ports on the NPort 5000 will be treated as if they were attached to your PC's own COM ports.

## Installing NPort CE Driver Manager

Copy "NPortCab.cab" to Windows CE and start to install driver by double clicking on it.

Click on "OK" to complete the installation when the following screen appears.

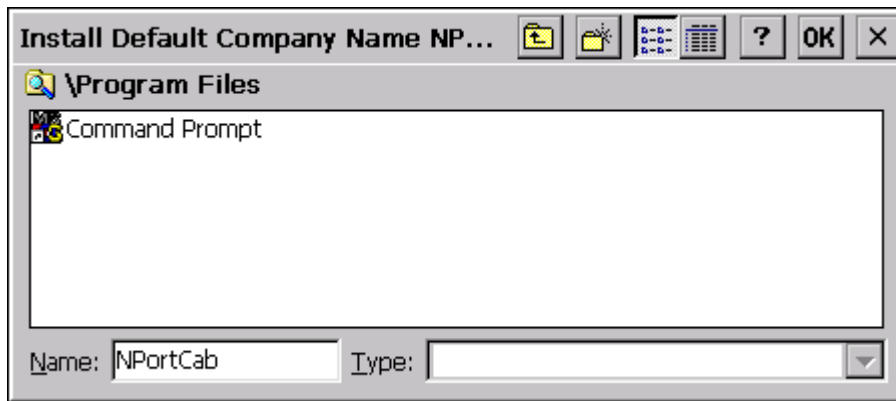

Driver installation is now complete and the "NPortCab.cab" icon disappear from the screen. This is normal when installing drivers in Windows CE.

## Using NPort CE Driver Manager

After you install NPort CE Driver Manager, you can set up the NPort's serial ports as remote COM ports for your Windows CE. Make sure that the serial port(s) on your NPort are set to Real COM mode when mapping COM ports with NPort CE Driver Manager.

Go to **Start** → **Programs** → **NPort CE Driver Manager**.

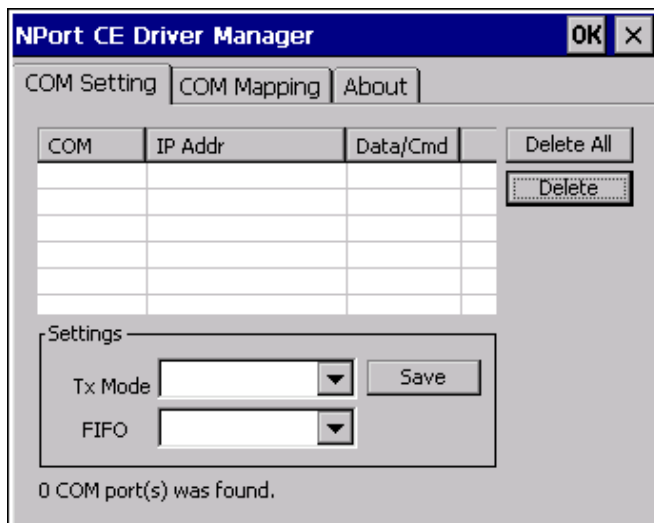

Click on the **COM Mapping** page and then the “Search” button to scan for NPort servers.

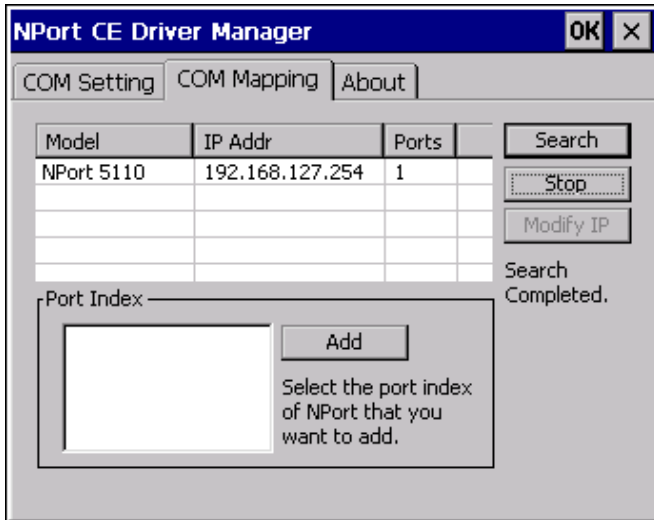

All NPort servers that were located will appear in the NPort CE Driver Manager window. Click on the server whose COM ports you would like to map to and then select the port index. Note that multiple selections are allowed.

Select the port(s) at the Port Index and then click on the “Add” button to map to the COM Port(s).

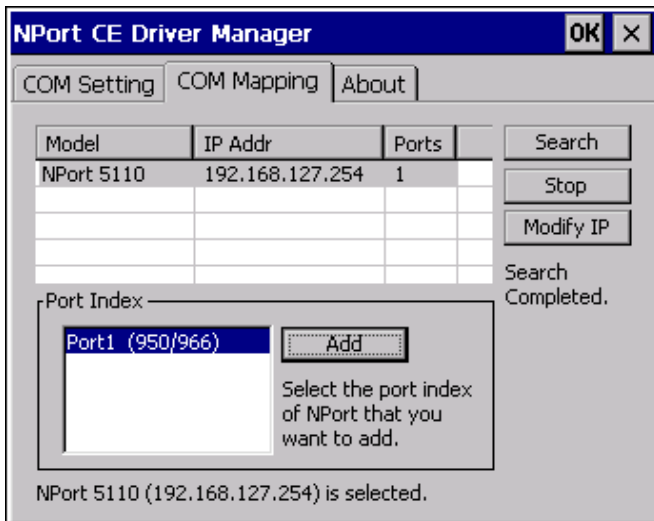

Return to the **COM Setting** page. You should be able to see the newly mapped COM Port(s).

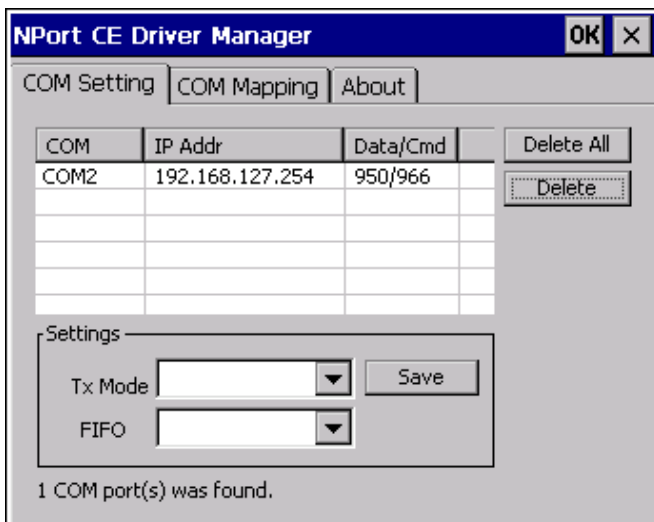

To configure the settings for a particular COM Port, select the row of the desired port, and then modify the setting in the “Settings” panel, as shown below.

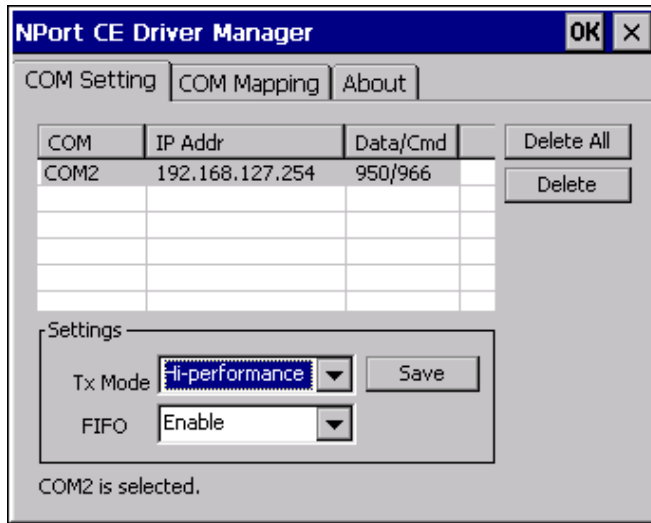

### Tx Mode

“Hi-Performance” is the default for Tx mode. After the driver sends data to the NPort server, the driver immediately issues a “Tx Empty” response to the program. Under “Classical mode,” the driver will not send the “Tx Empty” response until after confirmation is received from the NPort server’s serial port. This causes lower throughput. Classical mode is recommended if you want to ensure that all data is sent out before further processing.

### FIFO

If FIFO is disabled, the NPort server will transmit one byte each time the Tx FIFO becomes empty, and an Rx interrupt will be generated for each incoming byte. This will result in a faster response and lower throughput.

## Other Configuration Interfaces

---

The following topics are covered in this chapter:

- ❑ **Overview**

- ❑ **LCM Console (applies to DT models only)**

- Main Menu → Server setting
- Main Menu → Network setting
- Main Menu → Serial set
- Main Menu → Op Mode set
- Main Menu → Console
- Main Menu → LCM passwd prot
- Main Menu → Reset btn prot
- Main Menu → Ping
- Main Menu → Save/Restart

- ❑ **Telnet Console**

- ❑ **Serial Console (NPort 5600-8-DT)**

- ❑ **Serial Console (NPort 5600-8-DTL)**



## Overview

Typically, you will use either NPort Administrator or the web console to configure the NPort 5600-8-DT/DTL. These are not the only options for configuration. For basic onsite configuration, you can use the LCM console built into the device server, without requiring a connection to the network or a laptop. You may also connect to the serial console over the serial console port (port 1 for DTL models), or to the Telnet console over one of the Ethernet ports.

## LCM Console (applies to DT models only)

The **LCM** console refers to the LCD control panel on the top panel of the NPort 5600-8-DT. The LCM console can be used to view and modify basic settings, such as IP address. The **MENU** button activates the main menu. It is also used to cancel a selection and return to a previous menu. The **UP** and **DOWN** buttons navigate between available options. The **SEL** button selects an option or enters a submenu.

### Main Menu → Server setting

Under **Server setting**, you can view basic information about your device server. The following fields are displayed:

- Serial number
- Server name
- Firmware ver
- Model name

### Main Menu → Network setting

Under **Network setting**, you can view the device server's network settings and modify certain parameters such as IP address. The following fields are displayed:

- Ethernet1 statu
- Ethernet2 statu
- MAC address
- IP config
- IP address
- Netmask

### Main Menu → Serial set

Under **Serial set**, you can view each device port's serial communication settings and modify certain parameters such as baud rate. Settings are displayed and modified on a port-by-port basis. You will first select the port that you wish to modify or view. The following fields are displayed:

- Baud rate
- Data bit
- Stop bit
- Parity
- Flow control
- Tx/Rx fifo
- Interface
- Tx/Rx bytes
- Line status

## Main Menu → Op Mode set

Under **Op Mode set**, you can view or modify each device port's operation mode. You will first select the port that you wish to modify or view. Note that you can only select the operation mode. You will not be able to view or modify the advanced operation mode settings through the LCM console.

## Main Menu → Console

Under **Console**, you can enable or disable the web and Telnet consoles. The following fields are displayed:

- Web console
- Telnet console

## Main Menu → LCM passwd prot

**LCM passwd prot** refers to password protection for the LCM. If password protection is enabled, users will be required to enter the password in order to use the LCM console.

## Main Menu → Reset btn prot

**Reset btn prot** refers to reset button protection. If reset button protection is enabled, you will only be able to use the reset button in the first 60 seconds after powering on the NPort. After 60 seconds, the reset button will be disabled.

## Main Menu → Ping

You can use the built-in **Ping** function to verify network operation. Enter the IP address that you wish to ping and check the LCD screen for the response.

## Main Menu → Save/Restart

If any configuration changes are made through the LCM, you will need to **Save/Restart** for the changes to take effect.

## Telnet Console

You can use Telnet to open a terminal session with the NPort 5600-8-DT/DTL over one of the Ethernet ports. Simply Telnet to your device server's IP address. You will be presented with a text menu displaying the NPort 5600-8-DT/DTL's general settings, which you will be able to view and modify. Please refer to Chapter 4 for a description of the available settings.

If you are unable to connect to the Telnet console, it may be because it has been disabled through the LCM console.

## Serial Console (NPort 5600-8-DT)

You can connect to the serial console port to open the serial console. Connect to the console port with a serial-based terminal or terminal emulator program, such as Windows HyperTerminal. You may also download PComm Lite at [www.moxa.com](http://www.moxa.com). The terminal type should be set as ANSI or VT100, and the serial communication parameters should be set as 19200, 8, N, 1 (19200 for baud rate, 8 for data bits, None for parity, and 1 for stop bits). As soon as the connection is open, you will be presented with a text menu displaying the NPort 5600-8-DT's general settings. Please refer to Chapter 4 for a description of the available settings.

## Serial Console (NPort 5600-8-DTL)

You may use the RS-232 console port to set up the IP address for NPort 5600-8-DTL. We suggest using PComm Terminal Emulator, which is available free of charge as part of the PComm Lite program suite (found on the Software CD that comes with the product), to carry out the installation procedure, although other similar utilities may also be used.

Before you start to configure the NPort 5600-8-DTL via serial console, turn off the power and connect the serial cable from NPort 5600-8-DTL to your computer's serial port.

1. Connect NPort 5600-8-DTL's serial port 1 directly to your computer's male RS-232/422/485 serial port.
2. From the Windows desktop, click **Start → Programs → PComm Lite → Terminal Emulator**.
3. When the **PComm Terminal Emulator** window opens, first click on the **Port Manager** menu item and select **Open**, or simply click on the **Open** icon.



4. The **Property** window opens automatically. From the **Communication Parameter** page, select the appropriate COM port for the connection, **COM1** in this example, and **19200** for **Baud Rate**, **8** for **Data Bits**, **None** for **Parity**, and **1** for **Stop Bits**.

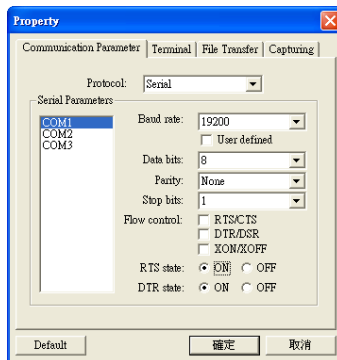

5. From the Property window's **Terminal** page, select **ANSI** or **VT100** for **Terminal Type** and then click **OK**. If you select **Dumb Terminal** as the terminal type, some of the console functions—especially the "Monitor" function—may not work properly.
6. Press the " ` " key continuously and then power on the NPort 5600-8-DTL.



7. The NPort 5600-8-DTL will receive the " ` " string continuously and then auto switch from data mode to console mode.
8. Input the password when prompted. Note that this page will only appear when the NPort 5600-8-DTL has been set up for password protection.

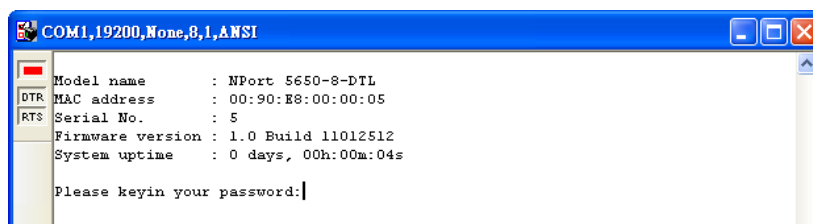

9. Start configuring the IP address under **Network Settings**. Refer to step 4 in the **Telnet Console** section for the rest of the IP settings.

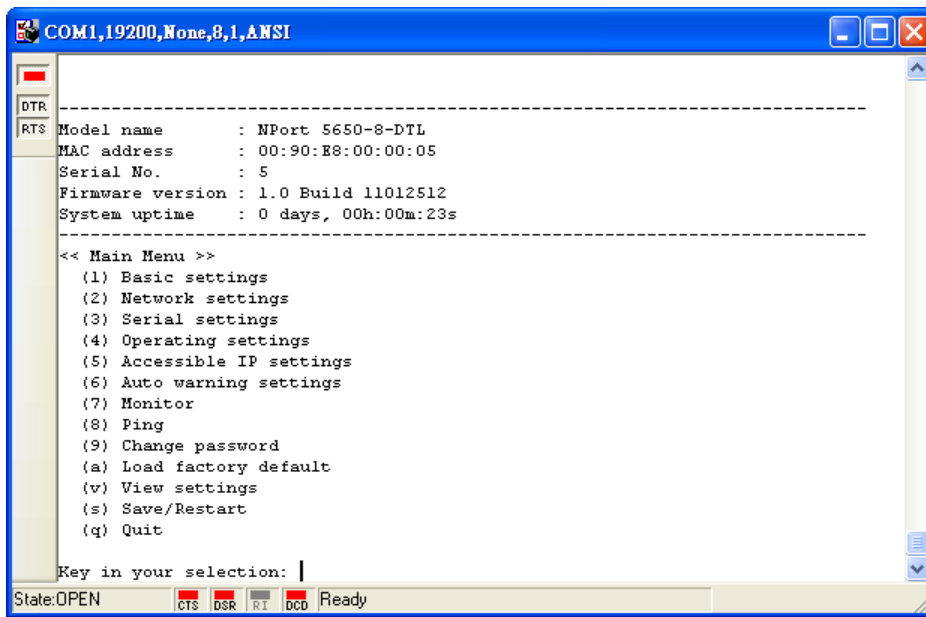

# TTY Drivers for Linux and UNIX

---

The following topics are covered in this chapter:

## ▣ **Linux Real TTY Drivers**

- Basic Steps
- Installing Linux Real TTY Driver Files
- Mapping TTY Ports
- Removing Mapped TTY Ports
- Removing Linux Driver Files

## ▣ **UNIX Fixed TTY Drivers**

- Installing the UNIX Driver
- Configuring the UNIX Driver

# Linux Real TTY Drivers

Real TTY driver are provided that will map Linux host TTY ports to NPort device ports. Once the mapping has been set up, Linux users and applications can connect to a device port as if it were a local TTY port. These drivers have been designed and tested for the majority of Linux distributions, including Linux kernel version 2.4.x and 2.6.x. Please check Moxa's website (<http://www.moxa.com>) for the latest Linux kernel support. For more detail, please refer to README.TXT.

## Basic Steps

Follow these instructions to map a TTY port to a device port:

Install the NPort device server and set the target device port to Real COM mode.

Install the Real TTY driver files on the Linux host.

Map the host's TTY port to the target device port on the NPort.

## Installing Linux Real TTY Driver Files

Before proceeding with the software installation, make sure you have completed the NPort device server has been installed and configured correctly. Note that the default IP address for the NPort is **192.168.127.254**.



### ATTENTION

The target device port must be operating in Real COM mode in order to map TTY ports.

1. Obtain the driver file from the Document and Software CD, or from the Moxa website at <http://www.moxa.com>.
2. Log in to the console as a super user (root).

Execute **cd /** to go to the root directory.

Copy the driver file **npreal2xx.tgz** to the / directory.

Execute **tar xvfz npreal2xx.tgz** to extract all files into the system.

Execute **/tmp/moxa/mxinst**.

For RedHat AS/ES/WS and Fedora Core1, append an extra argument as follows:

**# /tmp/moxa/mxinst SP1**

The shell script will install the driver files automatically.

After installing the driver, you will be able to see several files in the **/usr/lib/npreal2/driver** folder:

- > **mxaddsvr** (Add Server, mapping tty port)
- > **mxdelsvr** (Delete Server, un-mapping tty port)
- > **mxloadsvr** (Reload Server)
- > **mxmknod** (Create device node/tty port)
- > **mxrmnod** (Remove device node/tty port)
- > **mxuninst** (Remove tty port and driver files)

At this point, you may map the TTY port to the NPort serial port.

## Mapping TTY Ports

Make sure that you set the operation mode of the desired NPort serial port to Real COM mode. After logging in as a super user, enter the directory **/usr/lib/npreal2/driver** and then execute **mxaddsvr** to map the target NPort serial port to the host TTY ports. The syntax of **mxaddsvr** is as follows:

**mxaddsvr** [NPort IP Address] [Total Ports] ([Data port] [Cmd port])

The **mxaddsvr** command performs the following actions:

1. Modify `npreal2d.cf`.
2. Create TTY ports in directory `/dev` with major and minor number configured in `npreal2d.cf`.
3. Restart the driver.

#### **Mapping TTY ports automatically**

To map TTY ports automatically, you may execute **mxaddsvr** with just the IP address and number of ports, as in the following example:

```
# cd /usr/lib/npreal2/driver
# ./mxaddsvr 192.168.3.4 16
```

In this example, 16 TTY ports will be added, all with IP 192.168.3.4, with data ports from 950 to 965 and command ports from 966 to 981.

#### **Mapping TTY ports manually**

To map TTY ports manually, you may execute **mxaddsvr** and manually specify the data and command ports, as in the following example:

```
# cd /usr/lib/npreal2/driver
# ./mxaddsvr 192.168.3.4 16 4001 966
```

In this example, 16 TTY ports will be added, all with IP 192.168.3.4, with data ports from 4001 to 4016 and command ports from 966 to 981.

## Removing Mapped TTY Ports

After logging in as root, enter the directory `/usr/lib/npreal2/driver` and then execute **mxdelsvr** to delete a server. The syntax of **mxdelsvr** is:

```
mxdelsvr [IP Address]
```

Example:

```
# cd /usr/lib/npreal2/driver
# ./mxdelsvr 192.168.3.4
```

The following actions are performed when executing **mxdelsvr**:

1. Modify `npreal2d.cf`.
2. Remove the relevant TTY ports in directory `/dev`.
3. Restart the driver.

If the IP address is not provided in the command line, the program will list the installed servers and total ports on the screen. You will need to choose a server from the list for deletion.

## Removing Linux Driver Files

A utility is included that will remove all driver files, mapped TTY ports, and unload the driver. Enter the directory `/usr/lib/npreal2/driver`, then execute **mxuninst** to uninstall the driver. This program will perform the following actions:

1. Unload the driver.
2. Delete all files and directories in `/usr/lib/npreal2`.
3. Delete directory `/usr/lib/npreal2`.
4. Modify the system initializing script file.

# UNIX Fixed TTY Drivers

A fixed TTY driver is provided that will map UNIX host TTY ports to NPort device ports. Once the mapping has been set up, UNIX users and applications can connect to a device port as if it were a local TTY port. This driver has been designed and tested for the majority of UNIX systems. Please check Moxa's website (<http://www.moxa.com>) for the latest UNIX systems support. For more detail, please refer to README.TXT.

## Installing the UNIX Driver

1. Log in to UNIX and create a directory for the Moxa TTY. To create a directory named **/usr/etc**, execute the command:

```
# mkdir -p /usr/etc
```

2. Copy **moxattyd.tar** to the directory you created. For the **/usr/etc** directory, you would execute the following commands:

```
# cp moxattyd.tar /usr/etc
```

```
# cd /usr/etc
```

3. Extract the source files from the tar file by executing the command:

```
# tar xvf moxattyd.tar
```

The following files will be extracted:

**README.TXT**

**moxattyd.c** --- source code

**moxattyd.cf** --- an empty configuration file

**Makefile** --- makefile

**VERSION.TXT** --- fixed tty driver version

**FAQ.TXT**

4. Compile and link.

For SCO UNIX:

```
# make sco
```

For UnixWare 7:

```
# make svr5
```

For UnixWare 2.1.x, SVR4.2:

```
# make svr42
```

## Configuring the UNIX Driver

### Modify the configuration:

The configuration used by **moxattyd** is defined in the text file **moxattyd.cf**, which is in the same directory. You may use vi or any text editor to modify the file, as follows:

```
ttyp1 192.168.1.1 950
```

You can refer to **moxattyd.cf** for detailed descriptions of the various configuration parameters. Please note that "Device Name" depends on the OS. See the Device Naming Rule section in README.TXT for more information.

To start the **moxattyd** daemon after system bootup, add an entry into **/etc/inittab** using the TTY name you defined in **moxattyd.cf**, as in the following example:

```
ts:2:respawn:/usr/etc/moxattyd/moxattyd -t 1
```

### Device naming rule

For UnixWare 7, UnixWare 2.1.x, and SVR4.2, use:

```
pts/[n]
```

For all other UNIX operating systems, use:

```
ttyp[n]
```



The value of [n] should be equal or larger than 11 in order to prevent conflicts with the device names of functional keys in some UNIX systems.

### **Starting moxattyd**

Execute the command **init q** or reboot your UNIX operating system.

### **Adding an additional server**

Modify the text file **moxattyd.cf** to add an additional server. User may use vi or any text editor to modify the file. For more configuration information, refer to **moxattyd.cf**, which contains detailed descriptions of the various configuration parameters.

Find the process ID (PID) of the **moxattyd**.

```
# ps -ef | grep moxattyd
```

Update the configuration of **moxattyd**.

```
# kill -USR1 [PID]
```

(e.g., if moxattyd PID = 404, **kill -USR1 404**)

This completes the process of adding an additional server.

# 12

## The IP Serial Library

---

The following topics are covered in this chapter:

- **Overview**
- **IP Serial Library Function Groups**
- **Example Program**

# Overview

## What is the IP Serial Library?

The IP Serial Library is a Windows library with frequently used serial command sets and subroutines. It is designed to reduce the complexity and improve the efficiency of serial communication over TCP/IP. For example, Telnet can transfer data but cannot monitor or configure the serial line's parameters.

## Why use the IP Serial Library?

For programmers who are familiar with serial communication, the IP Serial Library provides well-designed function calls in the style of Moxa's PComm Library. It is simple and easy for programmers to understand. You can include the library in your Visual Basic, C, or Delphi programming environment and easily develop your own TCP/IP application with the ability to control serial communication parameters.

With the Real COM driver, two TCP ports are required for communication between the NPort and the host computer. The IP Serial Library requires one command port to communicate with the NPort. Serial communication can be controlled with just one TCP port (e.g., RFC 2217). The IP Serial Library not only runs with excellent efficiency but also runs without any decode or encode problems.

## How do I install the IP Serial Library?

The IP Serial Library comes with the NPort Administration Suite. Please refer to the IP Serial directory for details about the available functions.

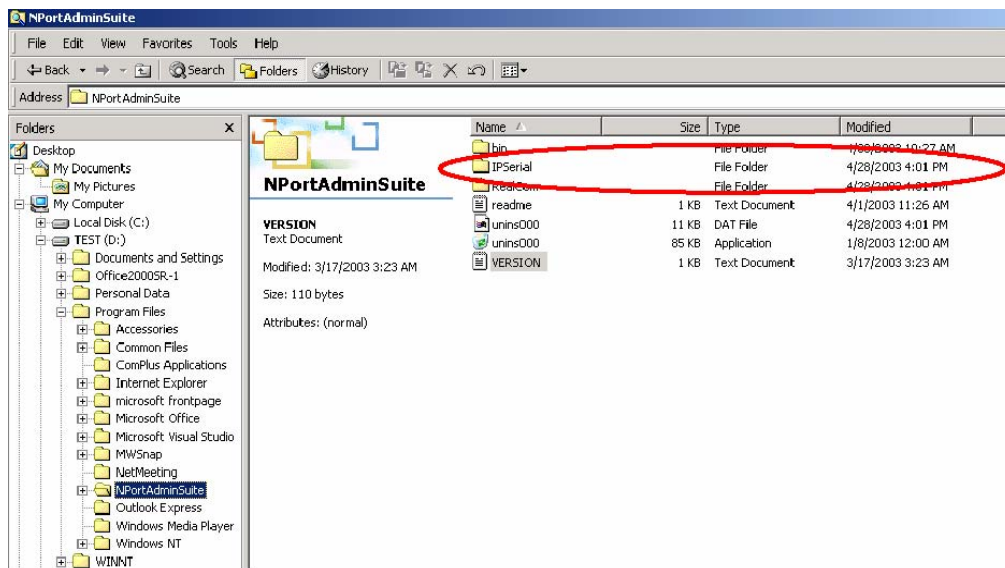

## IP Serial Library Function Groups

Server Control	Port Control	Input/Output Data	Port Status Inquiry	Miscellaneous
nsio_init nsio_end nsio_resetserver nsio_checkalive	nsio_open nsio_close nsio_ioctl nsio_flowctrl nsio_DTR nsio_lctrl nsio_baud nsio_resetport	nsio_read nsio_SetReadTimeo uts nsio_write nsio_SetWriteTimeo uts	nsio_lstatus nsio_data_status	nsio_break nsio_break_on nsio_break_off nsio_breakcount

## Example Program

```
char nportip="192.168.1.10";
char buffer[255];
int port = 1; int portid; nsio_init();
portid = nsio_open(nportip, port); nsio_ioctl(portid,
B9600, (BIT_8 | STOP_1 | P_NONE) );
sleep(1000);
nsio_read(port, buffer, 200); nsio_close(portid);
nsio_end();

/*data buffer, 255 chars */
/*1st port */
/* port handle */
/*initial IP Serial Library */
/*1st port, nport IP=192.168.1.10 */
/*set 9600, N81 */
/* wait for 1000 ms for data */
/* read 200 bytes from port 1 */
/* close this serial port */
/* close IP Serial Library */
```

In this chapter, we describe a straightforward procedure that can be used to troubleshoot problems you encounter when operating your NPort. We recommend that you follow these step by step instructions first before contacting Moxa's technical support team.

## Connection Problems

### **Step 1: Does the Ethernet LED light up?**

If not, try the following:

- Use a straight-through Ethernet cable to connect the unit to the network.
- Use an Ethernet cable that is less than 100 meters long.
- Make sure there is no defect with your hub or switch's Ethernet port.

### **Step 2: Does your hub, switch, or NIC's "Link" LED light up?**

If not, try the following:

- Use a straight-through Ethernet cable to connect the unit to the network.
- Make sure the NIC (if applicable) is installed correctly.
- Use an Ethernet cable that is less than 100 meters long.
- Make sure there is no defect with your hub or switch's Ethernet port.

### **Step 3: Can you ping the device server from your host?**

If not, try the following:

- Make sure that there are no problems with IP configuration.
- If a router is not used, make sure that the device server and the host must be on the same network subnet if a router is not used.
- If a router is used, make sure that gateway and routing settings are correct. Use "tracert" to follow up. Make sure that the routers don't filter PING (ICMP) or port numbers. Refer to Moxa FAQ #441 for the proper TCP/UDP ports.

### **Step 4: Is the correct operation mode being used?**

If not, try the following:

- Select the proper operation mode for the device port in the web console or in NPort Administrator. Remember, each device port is set to Real COM mode by default.
- Save changes and restart the device server to activate new settings.

## Operation Mode Problems

### Real COM Mode

#### **Step 1: Are you able to install the drivers successfully?**

If not, try the following:

- For NAT environments, use NAT port mapping.
- Verify that ping response time is less than 1000 ms.
- Go over the installation procedures again in the user's manual.

**Step 2: Are you able to open the device port on the NPort?**

If not, try the following:

- If the device server is across a router or firewall, try opening TCP ports between 950 and 965 and between 966 and 981.
- Verify that access rights are correctly defined in the Accessible IP Table.
- Check for DHCP issues by having the DHCP server assign a fixed IP to the NPort.
- See if the selected TCP port is occupied by checking connection status.
- Make sure there are no COM port conflicts and no one else is using the same COM number.
- Apply and save any configuration changes.

**Step 3: Are the advanced functions configured correctly?**

Try the following measures:

- Disable the FIFO if the attached device experiences significant data loss.
- If confirmation of device response is critical, set Tx mode to "Classical mode".
- If performance is sluggish, enable Fast Flush.

## TCP Server Mode

**Is the remote TCP client program able to connect to the NPort properly?**

If not, try the following:

- Verify that the TCP listen port matches your TCP client program.
- Check for DHCP issues by having the DHCP server assign a fixed IP to the NPort.
- Check that Accessible IP settings are blank or include the host's IP address.
- See if the selected TCP port is occupied by checking connection status.

## TCP Client Mode

**Is the NPort connecting to the remote TCP server program properly?**

If not, try the following:

- Verify that the TCP destination port matches your TCP server program.
- Check for DHCP issues by having the DHCP server assign a fixed IP to the NPort.
- Verify that the NPort's Destination IP matches your host's IP address.

## UDP Mode

**Is the remote UDP program properly receiving and transmitting data?**

If not, try the following:

- Clean up network traffic if possible to prevent data loss.
- Make sure your AP is configured with a resending mechanism when data is lost.
- Switch to TCP Server/Client mode
- Verify that the designated UDP port matches your application.
- Check for DHCP issues by having the DHCP server assign a fixed IP to the NPort.
- Open the specific UDP port to check for router filtering issues.

## Serial Data Problems

Try the following measures:

- Make sure there are no cable wiring issues. 3 or 8-wire cabling should be used for RS-232, point-to-point 4-wire cabling for RS-422, and daisy-chain 2 or 4-wire cabling for RS-485.
- Verify that all serial communication settings correspond with the attached device.
- Make sure there are no cable length issues. At 9600 bps, RS-232 cables should be no longer than 15 m, RS-422 cables no longer than 1.2 km, and RS-485 cables no longer than 1.2 km.
- Check for RS-422 or RS-485 driving issues, such as terminator problems or pull high/low settings.
- Check flow control settings. If you are using RTS/CTS flow control, you must have appropriate RTS and CTS wiring.

# A

## Cable Wiring

---

The following topics are covered in this appendix:

- RS-232 Cables
- RS-422, 4-wire RS-485 Cables
- 2-wire RS-485 Cables



## RS-232 Cables

NPort	NPort Connector		Direction	Serial Device Connector			Serial Device
	RJ45	DB9(F)		DB9(M)	DB25(M)	DB25(F)	
DSR	1	6	←	4	6	20	DTR
RTS	2	7	→	8	4	5	CTS
GND	3	5	—	5	7	7	GND
TxD	4	3	→	2	2	3	RxD
RxD	5	2	←	3	3	2	TxD
DCD	6	1	←	1	8	8	DCD
CTS	7	8	←	7	5	4	RTS
DTR	8	4	→	6	20	6	DSR

## RS-422, 4-wire RS-485 Cables

NPort	NPort Connector		Direction	Serial Device Connector			Serial Device
	RJ45	DB9(F)		DB9(M)	DB25(M)	DB25(F)	
TxD+	2	2	→	3	3	2	RxD+
GND	3	5	—	5	7	7	GND
TxD-	4	1	→	1	8	8	RxD-
RxD+	5	3	←	2	2	3	TxD+
RxD-	6	4	←	6	20	6	TxD-

## 2-wire RS-485 Cables

NPort	NPort Connector		Direction	Serial Device Connector			Serial Device
	RJ45	DB9(F)		DB9(M)	DB25(M)	DB25(F)	
GND	3	5	—	5	7	7	GND
Data+	5	3	↔	2	2	3	Data+
Data-	6	4	↔	6	20	6	Data-

# B

## SNMP Agent with MIB II & RS-232-Like Group

---

SNMP (Simple Network Management Protocol) agent software is built into the NPort 5600-8-DT/DTL. It supports SNMP Trap, the RFC1317 RS-232-like group, and RFC1213 MIB-II. The following table lists the standard MIB-II group and the variable implementation for the NPort 5600-8-DT/DTL.

### RFC1213 MIB-II supported SNMP variables:

System MIB	Interfaces MIB	IP MIB	ICMP MIB
SysDescr	ifNumber	ipForwarding	IcmpInMsgs
SysObjectID	ifIndex	ipDefaultTTL	IcmpInErrors
SysUpTime	ifDescr	ipInreceives	IcmpInDestUnreachs
SysContact	ifType	ipInHdrErrors	IcmpInTimeExcds
SysName	ifMtu	ipInAddrErrors	IcmpInParmProbs
SysLocation	ifSpeed	ipForwDatagrams	IcmpInSrcQuenchs
SysServices	ifPhysAddress	ipInUnknownProtos	IcmpInRedirects
	ifAdminStatus	ipInDiscards	IcmpInEchos
	ifOperStatus	ipInDelivers	IcmpInEchoReps
	ifLastChange	ipOutRequests	IcmpInTimestamps
	ifInOctets	ipOutDiscards	IcmpTimestampReps
	ifInUcastPkts	ipOutNoRoutes	IcmpInAddrMasks
	ifInNUcastPkts	ipReasmTimeout	IcmpOutMsgs
	ifInDiscards	ipReasmReqds	IcmpOutErrors
	ifInErrors	ipReasmOKs	IcmpOutDestUnreachs
	ifInUnknownProtos	ipReasmFails	IcmpOutTimeExcds
	ifOutOctets	ipFragOKs	IcmpOutParmProbs
	ifOutUcastPkts	ipFragFails	IcmpOutSrcQuenchs
	ifOutNUcastPkts	ipFragCreates	IcmpOutRedirects
	ifOutDiscards	ipAdEntAddr	IcmpOutEchos
	ifOutErrors	ipAdEntIfIndex	IcmpOutEchoReps

System MIB	Interfaces MIB	IP MIB	ICMP MIB
	ifOutQLen	ipAdEntNetMask	IcmpOutTimestamps
	ifSpecific	ipAdEntBcastAddr	IcmpOutTimestampReps
		ipAdEntReasmMaxSize	IcmpOutAddrMasks
		IpNetToMediaIfIndex	IcmpOutAddrMaskReps
		IpNetToMediaPhysAddress	
		IpNetToMediaNetAddress	
		IpNetToMediaType	
		IpRoutingDiscards	

UDP MIB	TCP MIB	SNMP MIB
UdpInDatagrams	tcpRtoAlgorithm	snmpInPkts
UdpNoPorts	tcpRtoMin	snmpOutPkts
UdpInErrors	tcpRtoMax	snmpInBadVersions
UdpOutDatagrams	tcpMaxConn	snmpInBadCommunityNames
UdpLocalAddress	tcpActiveOpens	snmpInASNParseErrs
UdpLocalPort	tcpPassiveOpens	snmpInTooBigS
	tcpAttempFails	snmpInNoSuchNames
Address Translation MIB	tcpEstabResets	snmpInBadValues
AtIfIndex	tcpCurrEstab	snmpInReadOnlys
AtPhysAddress	tcpInSegs	snmpInGenErrs
AtNetAddress	tcpOutSegs	snmpInTotalReqVars
Address Translation MIB	TCP MIB	SNMP MIB
AtNetAddress	tcpRetransSegs	snmpInTotalSetVars
	tcpConnState	snmpInGetRequests
	tcpConnLocalAddress	snmpInGetNexts
	tcpConnLocalPort	snmpInSetRequests
	tcpConnRemAddress	snmpInGetResponses
	tcpConnRemPort	snmpInTraps
	tcpInErrs	snmpOutTooBigS
	tcpOutRsts	snmpOutNoSuchNames
		snmpOutBadValues
		snmpOutGenErrs
		snmpOutGetRequests
		snmpOutGetNexts
		snmpOutSetRequests

Address Translation MIB	TCP MIB	SNMP MIB
		snmpOutGetResponses
		snmpOutTraps
		snmpEnableAuthenTraps

**RFC1317: RS-232 MIB objects**

Generic RS-232-like Group	RS-232-like General Port Table	RS-232-like Asynchronous Port Group
rs232Number	rs232PortTable	rs232AsyncPortTable
	rs232PortEntry	rs232AsyncPortEntry
	rs232PortIndex	rs232AsyncPortIndex
	rs232PortType	rs232AsyncPortBits
	rs232PortInSigNumber	rs232AsyncPortStopBits
	rs232PortOutSigNumber	rs232AsyncPortParity
	rs232PortInSpeed	
	rs232PortOutSpeed	

Input Signal Table	Output Signal Table
rs232InSigTable	rs232OutSigTable
rs232InSigEntry	rs232OutSigEntry
rs232InSigPortIndex	rs232OutSigPortIndex
rs232InSigName	rs232OutSigName
rs232InSigState	rs232OutSigState

# IP Report Protocol

---

There are several ways to configure the IP address of the NPort device server. One of them is DHCP Client. When you set up the device server to use DHCP Client for IP address configuration, it will automatically send a DHCP request over the network to find the DHCP server. The DHCP server will then send an available IP address to the NPort with an expiration time. The NPort will use this IP address until the expiration time has been reached. When the expiration time has been reached, the process will repeat, and NPort will send another DHCP request to the DHCP server. Therefore, an NPort may end up using more than one IP address while it is connected to the network.

The NPort has a built-in IP address report function that will send its IP data to a specific IP address and port number when it is configured with a dynamic IP address. In the web console, the IP report parameters may be configured under Network Settings. Enter the IP address and the port number of the PC that is to receive this information, as well as the reporting interval

To interpret the IP address report, the destination PC needs to have NPort Administrator installed with the IP Address Report function activated. You may also use develop your own application to receive the IP address report by referring to the IP report protocol described here. An example program is provided on the Moxa website at [www.moxa.com](http://www.moxa.com).

## IP Address Report Structure

The first 4 bytes of the module's IP address report are the characters "Moxa". The rest of the report is composed of 9 items, with each item preceded by a 2-byte header indicating the item ID and item length.

Header (Item ID)	Header (Item Length)	Item
(none)	(none)	"Moxa" (text string)
1	(varies)	server name (text string)
2	2	hardware ID (little endian, see table below)
3	6	MAC address (00-90-E8-01-02-03 would be sent in sequence as 0x00, 0x90, 0xE8, 0x01, 0x02, 0x03)
4	4	serial number (little endian DWORD)
5	4	IP address
6	4	netmask
7	4	default gateway
8	4	firmware version (little endian DWORD, Version 4.3.1 would be 0x04030100)
9	4	AP ID (little endian DWORD, see table below)

# Hardware and AP ID

Each model is assigned a Hardware ID and AP ID as shown below:

Hardware ID	AP ID	Product
0x5700	0x80015610	5610-8-DT
0x5702	0x80015610	5650-8-DT
0x5703	0x80015610	5650I-8-DT
0x5704	0x80015610	5610-8-DT-J
0x5706	0x80015610	5650-8-DT-J
0x5710	0x80025610	5610-8-DTL
0x5711	0x80025610	5650-8-DTL
0x5712	0x80025610	5650I-8-DTL

## Example

The following example shows the first 22 bytes of a typical IP address report:

	report header "Moxa"				item ID	item length	server name "TEST"				item ID	item length	hardware ID 0x516		item ID	item length	MAC address 00-90-E8-01-02-03						
HEX	4D	4F	58	41	01	04	54	45	53	54	02	02	16	05	03	06	00	90	E8	01	02	03	
ASCII	"M"	"O"	"X"	"A"			"T"	"E"	"S"	"T"													

## Compliance Notice

---



### **CE Warning**

This is a Class A product. In a domestic environment, this product may cause radio interference in which case the user may be required to take appropriate measures.

### **Federal Communications Commission Statement**

FCC - This device complies with part 15 of the FCC Rules. Operation is subject to the following two conditions: (1) This device may not cause harmful interference, and (2) this device must accept any interference received, including interference that may cause undesired operation.



### **FCC Warning**

This equipment has been tested and found to comply with the limits for a Class A digital device, pursuant to part 15 of the FCC Rules. These limits are designed to provide reasonable protection against harmful interference when the equipment is operated in a commercial environment. This equipment generates, uses, and can radiate radio frequency energy and, if not installed and used in accordance with the instruction manual, may cause harmful interference to radio communications. Operation of this equipment in a residential area is likely to cause harmful interference in which case the user will be required to correct the interference at his own expense.