



NPort W2150A/W2250A Series Quick Installation Guide

First Edition, April 2012

1. Overview

The NPort W2150A/W2250A wireless device servers are an ideal choice for connecting serial devices such as PLCs, meters, and sensors to an IP-based wireless LAN or Ethernet LAN.

Features

- Link any serial device to an IEEE 802.11a/b/g network.
- 1 and 2-port RS-232/422/485 models, up to 921.6 Kbps.
- Web-based configuration over Ethernet or wireless LAN.
- Enhanced security for remote configuration with HTTPS, SSH.
- Secure data access with WEP, WPA, WPA2.
- Built-in WLAN site survey tool.
- Fast roaming when signal strength is weak.
- Per-port offline port buffering and serial data log.
- Dual power inputs via power jack and terminal block.

2. Package Checklist

Before installing the NPort W2150A/W2250A device server, verify that the package contains the following items:

- 1 NPort W2150A, NPort W2150A-T, NPort W2250A, or NPort W2250A-T.
- Document and Software CD.
- RJ45 to RJ45 cross-over Ethernet cable.
- Warranty Statement.
- Quick Installation Guide.

Optional Accessories

- DK-35A (35 mm DIN-Rail Mounting Kit).
- Power jack to terminal block power cable (P/N: 919900000900).

Note: Notify your sales representative if any of the above items are missing or damaged.

3. Hardware Introduction

The NPort W2150A models have one serial port, and the NPort W2250A models have two serial ports. All models support RS-232/422/485 operation with DB9 connectors, and include one 10/100M Ethernet port.

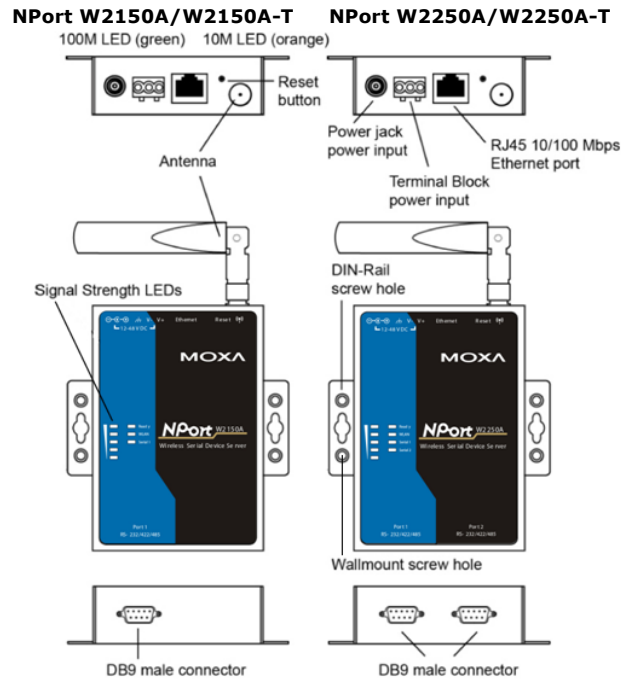

Reset Button—The reset button is used to load factory default settings. Use a pointed object to hold the reset button down for 5 seconds to load factory defaults.

End Panel LED Indicators

Name	Color	Function
Ethernet	Orange	10 Mbps Ethernet connection
	Green	100 Mbps Ethernet connection
	Off	Ethernet cable is disconnected

Top Panel LED Indicators

Name	Color	Function
Ready	Red	Steady on: Power is on and NPort is booting up
		Blinking: IP conflict or DHCP/BOOTP server did not respond properly
	Green	Steady on: NPort is functioning normally Blinking: NPort is responding to Locate function
WLAN	Green	Off: Power is off or a power error condition exists
		Steady on: Wireless enabled Blinking: NPort can't establish WLAN connection with AP (Infrastructure) or station (Ad-Hoc)
	Off	Wireless not enabled

Name	Color	Function
Serial 1 Serial 2	Orange	Serial port is receiving data
	Green	Serial port is transmitting data
	Off	No data is flowing to or from the serial port
Signal Strength	Red	1 Red - the signal strength is between 0% to 20%
		2 Red - the signal strength is between 21% to 40%
	Green	3 Green - the signal strength is between 41% to 60%
		4 Green - the signal strength is between 61% to 80%
		5 Green - the signal strength is between 81% to 100%

4. Pull High/Low Resistors and Terminal Resistor for RS-422/485

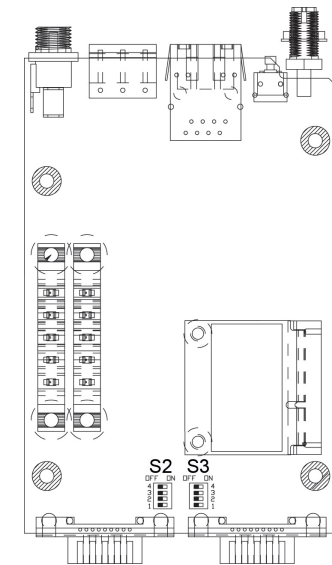

You may need to set the pull high/low resistors when termination resistors are used for certain RS-422 or RS-485 environments.

S2(Serial 1) S3(Serial 2)	DIP 1	DIP 2	DIP 3	DIP 4
	Pull high Resistor	Pull low Resistor	Terminal Resistor	Reserved
ON	1K Ω	1K Ω	120 Ω	----
OFF	*150K Ω	*150K Ω	*N/A	----

* Default
S3 is for NPort W2250A only.

NOTE Do not use the 1 K Ω setting while in RS-232 mode. Doing so will degrade the RS-232 signals and reduce the effective communication distance.

5. First-time Hardware Installation

- STEP 1: After removing the NPort W2150A/W2250A from the box, use a cross-over Ethernet cable to connect the NPort's RJ45 Ethernet port directly to your computer's Ethernet port.
- STEP 2: Attach the power adaptor to the NPort and then plug the adaptor into an electrical outlet.
- STEP 3: Configure the NPort W2150A/W2250A through the Ethernet port. See the next section for software installation information.

NOTE You must connect the Ethernet cable first before powering up your NPort

6. Software Installation Information

Insert the Document & Software CD into your PC. A window should open with several options displayed:

- Click **[Install COM Driver]** and follow the on-screen instructions to install the COM drivers.
- Click **[Documents]** and select "NPort W2150A/W2250A Series User's Manual" to view the user's manual.
- Click **[Install UTILITY]** and follow the on-screen instructions to install the NPort Search Utility. This utility can be used to search for NPort W2150A/W2250A units on the network.

7. Setting the IP Address

The factory default IP settings are assigned as follows:

LAN: Static; IP = 192.168.126.254; netmask = 255.255.255.0
 WLAN: Static; IP = 192.168.127.254; netmask = 255.255.255.0

If the NPort is configured for DHCP but the DHCP server cannot be found, the NPort will use factory default IP settings.

NOTE If you have forgotten the NPort's IP address, use the NPort Search Utility from your PC to locate the NPort. After searching the LAN for NPort units, the NPort Search Utility will display the IP address of each unit.

NOTE Only one network interface can be active at a time. If the Ethernet link is active, the WLAN will be inactive. If the WLAN is active, the Ethernet link will be inactive.

Open the web console to make configuration changes as follows:

- STEP 1: Open your web browser.
- STEP 2: In the address bar, enter 192.168.126.254 (the default IP address).
- STEP 3: The web console will open, and the current configuration settings are shown.
- STEP 4: For first time use, click the **Wizard** in the left navigation panel. The wizard will prompt you to configure the IP address, SSID, and security mode. For other settings, use the factory defaults or modify the settings for your application.

8. Pin Assignments and Cable Wiring

Pin	RS-232	RS-422, 4w RS-485	2w RS-485
1	DCD	TxD-(A)	---
2	RxD	TxD+(B)	---
3	TxD	RxD+(B)	Data+(B)
4	DTR	RxD-(A)	Data-(A)
5	GND	GND	GND
6	DSR	---	---
7	RTS	---	---
8	CTS	---	---
9	---	---	---

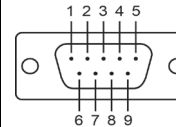

Female DB9 to Male DB9

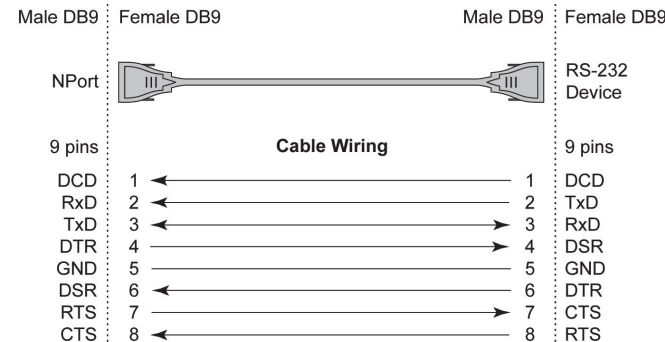

Female DB9 to Male DB25

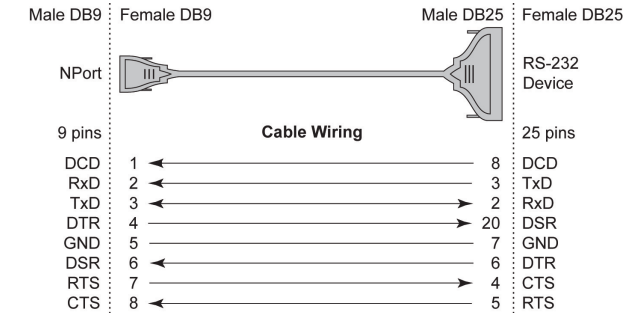

9. Specifications

Power Requirements

Power Input	12 to 48 VDC
Power Consumption	237mA @ 12V
Power Connector	Screw type power jack and terminal block

Physical Characteristics

Material	Aluminum sheet metal (1 mm)
Dimensions	77 × 111 × 26 mm (no ears, no antenna) 100 × 111 × 26 mm (with ears, no antenna)
Antenna Length	109 mm
Magnetic Isolation	1.5 kV magnetic isolation built-in

Environmental Limits

Operating Temperature	Standard Models: 0 to 55°C (32 to 131°F), 5 to 95%RH Wide Temp. Models: -40 to 75°C (-40 to 167°F), 5 to 95%RH -40 to 85°C (-40 to 185°F), 5 to 95%RH
Storage Temperature	-40 to 85°C (-40 to 185°F), 5 to 95%RH

Regulatory Approvals

EMC	CE: EN 55022 Class A/EN 55024 ETSI EN 301 489-17, ETSI EN 301 489-1
	FCC: FCC Part 17 Subpart B, Class A FCC Part 15 Subpart B, Class A
Safety	UL: UL 60950-1 LVD: EN 60950-1 DSPR: ARIB-STD 33, ARIB-STD 66

MOXA® www.moxa.com/support

The Americas: +1-714-528-6777 (toll-free: 1-888-669-2872)
 Europe: +49-89-3 70 03 99-0
 Asia-Pacific: +886-2-8919-1230
 China: +86-21-5258-9955 (toll-free: 800-820-5036)

© 2012 Moxa Inc. All rights reserved.