

NE-4000T Series User's Manual

www.moxa.com/product

Fifth Edition, June 2008

MOXA®

© 2008 Moxa Inc., all rights reserved.
Reproduction without permission is prohibited.

NE-4000T Series User's Manual

The software described in this manual is furnished under a license agreement and may be used only in accordance with the terms of that agreement.

Copyright Notice

Copyright © 2008 Moxa Inc.
All rights reserved.
Reproduction without permission is prohibited.

Trademarks

MOXA is a registered trademark of Moxa.
All other trademarks or registered marks in this manual belong to their respective manufacturers.

Disclaimer

Information in this document is subject to change without notice and does not represent a commitment on the part of Moxa.

Moxa provides this document “as is,” without warranty of any kind, either expressed or implied, including, but not limited to, its particular purpose. Moxa reserves the right to make improvements and/or changes to this manual, or to the products and/or the programs described in this manual, at any time.

Information provided in this manual is intended to be accurate and reliable. However, Moxa assumes no responsibility for its use, or for any infringements on the rights of third parties that may result from its use.

This product might include unintentional technical or typographical errors. Changes are periodically made to the information herein to correct such errors, and these changes are incorporated into new editions of the publication.

Technical Support Contact Information

www.moxa.com/support

Moxa Americas:

Toll-free: 1-888-669-2872

Tel: +1-714-528-6777

Fax: +1-714-528-6778

Moxa China (Shanghai office):

Toll-free: 800-820-5036

Tel: +86-21-5258-9955

Fax: +86-10-6872-3958

Moxa Europe:

Tel: +49-89-3 70 03 99-0

Fax: +49-89-3 70 03 99-99

Moxa Asia-Pacific:

Tel: +886-2-8919-1230

Fax: +886-2-8919-1231

Table of Contents

Chapter 1	Introduction	1-1
	Overview.....	1-2
	Package Checklist	1-2
	Product Features	1-2
	Product Specifications	1-3
Chapter 2	Panel Layout and Pin Assignments	2-1
	NE-4000T Module	2-2
	Panel Layout.....	2-2
	Pin Assignments	2-3
	Block Diagram.....	2-3
	NE-4000T-ST Starter Kit	2-4
	Ethernet Port Pinouts (RJ45)	2-4
	Serial Port Pinouts (Male DB9).....	2-4
	DIO Pin Headers.....	2-5
	LED Indicators	2-5
Chapter 3	Getting Started	3-1
	Wiring Requirements	3-2
	Plugging NE-4000T into NE-4000T-ST	3-2
	Connecting the Power	3-3
	Connecting to the Network	3-3
	Connecting to a Serial Device.....	3-3
	DI/O Settings	3-3
	Digital Output.....	3-3
	Digital Input.....	3-4
	Digital Output LED Circuit Design	3-4
	Operating Modes.....	3-4
	Real COM Mode (NE-4000T-RC)	3-5
	TCP Server Mode (NE-4000T-TS).....	3-5
	TCP Client Mode (NE-4000T-TC).....	3-6
	UDP Mode (NE-4000T-UD)	3-6
Chapter 4	Network Enabler Administrator	4-1
	Installing Network Enabler Administrator	4-2
	Configuration Window.....	4-5
	Broadcast Search.....	4-6
	Specify by IP Address	4-7
	NE-4000T Configuration Information	4-9
	Status Settings.....	4-9
	Unlock Password Protection	4-10
	Configuring NE-4000T	4-11
	Basic	4-12
	Network	4-13
	Serial.....	4-14
	Operating Mode	4-16
	Accessible IPs.....	4-26
	Password.....	4-28
	Digital I/O.....	4-28
	Export/Import Functions.....	4-31

Chapter 5	Web Console Configuration	5-1
	Opening Your Browser.....	5-2
	Network Settings.....	5-4
	Accessible IP Settings.....	5-6
	Change Password.....	5-8
	Restart/Logout	5-8
Chapter 6	Serial Console Configuration.....	6-1
Chapter 7	Upgrading the Firmware.....	7-1
Appendix A	Well Known Port Numbers	A-1
Appendix B	NECI Library	B-1
Appendix C	DIO Commands	C-1

Moxa's NE-4000T Series of Embedded Network Enablers is designed to turn serial devices into true network devices. Smaller than a credit card, NE-4000T comes with the right combination of hardware and software features to make product development efficient and straightforward. Four NE-4000T models are available.

- NE-4000T-RC supports Real COM Mode ← *Contact Moxa**
- NE-4000T-TS supports TCP Server Mode
- NE-4000T-TC supports TCP Client Mode ← *Contact Moxa**
- NE-4000T-UD supports UDP Mode ← *Contact Moxa**

** Models NE-4000T-RC, NE-4000T-TC, and NE-4000T-UD are available for project-based orders only. Please contact the Moxa sales representative nearest you for more information.*

This chapter covers the following topics:

- ❑ **Overview**
- ❑ **Package Checklist**
- ❑ **Product Features**
- ❑ **Product Specifications**

Overview

The NE-4000T modules measure just 44 × 31.48 mm, or less than half the size of a typical credit card, making NE-4000T small enough to fit inside most serial devices. NE-4000T comes with the TCP/IP stack built into the firmware, making the task of integrating NE-4000T module with your serial devices efficient and straightforward. Engineers will not need to spend a lot of time on TCP/IP programming, but instead can focus on developing other major features, shortening the time to market of your new products.

The reliable TCP/IP communication firmware that comes with the NE-4000T Series can be configured very easily with the user-friendly Windows utility or by serial console. The product also has a Web console for basic configuration by web browser. In addition, a Windows-based NECI (Network Enabler Configuration Interface) Library is available to help you develop your own Windows utilities.

An integration kit (NE-4000T-ST) containing a development board, documents, sample code, cables, and accessories is available for testing and product development.

Package Checklist

- 1 NE-4000T
- 1 NE-4000T-ST
- NE-4000T Documentation & Software CD
- NE-4000T Quick Installation Guide
- Universal Power Adaptor Set
- Null modem cable
- Product Warranty Booklet

NOTE: *Notify your sales representative if any of the above items is missing or damaged.*

Product Features

NE-4000T has the following features:

- TTL Interface (up to 115.2 Kbps)
- 10M Ethernet with built-in transformer
- Ready-to-use TCP/IP firmware
- Compact size
- Dual-in-line pin headers
- Low power consumption
- Web-based Administrator utility
- Menu-driven serial console utility
- Accessible by browser
- NECI Library for developing your own configuration utility
- Highly expandable with up to 8 DIOs (GPIOs)

Product Specifications

System

CPU	8-bit MCU
RAM	32 KB
Flash	64 KB

LAN

Ethernet	10 Mbps, pin headers
Protection	Built-in transformer with 1.5 KV magnetic isolation

Serial

Interface	TTL
Port Type	Pin header
Signals	TxD, RxD, RTS, CTS, GND

Serial Communication Parameters

Parity	None, Even, Odd
Data Bits	8
Stop Bit	1, 2
Flow Control	RTS/CTS, XON/XOFF
Transmission Speed	300 bps to 115.2 Kbps

Software Features

Protocols	ICMP, ARP, IP, TCP, UDP, DHCP, HTTP
Operation Modes	NE-4000T-RC: Real COM Mode NE-4000T-TS: TCP Server Mode NE-4000T-TC: TCP Client Mode NE-4000T-UD: UDP Mode
Utilities	Administrator utility for Windows 95/98/ME/NT/2000/XP
Configuration	Windows Utility, Serial Console, or Web Browser

Power Requirements

Power Input	5 VDC, $\pm 5\%$
Power Consumption	65 mA @ 5 VDC (Max.)

Environment

Operating Temperature	0 to 70°C (32 to 158°F), 5 to 95%RH
Storage Temperature	-20 to 85°C (-4 to 185°F), 5 to 95%RH

Regulatory Approvals

EMC	FCC Class B, CE Class B
WARRANTY	5 years

2

Panel Layout and Pin Assignments

In this chapter, we show the panel layouts and pin assignments for the NE-4000T Embedded Network Enabler module and NE-4000T-ST Starter Kit. You can use the Starter Kit to test the NE-4000T module to determine if it's the right product for your application, and then use it to develop programs for your applications.

This chapter covers the following topics:

- ❑ **NE-4000T Module**
 - Panel Layout
 - Pin Assignments
 - Block Diagram
- ❑ **NE-4000T-ST Starter Kit**
 - Ethernet Port Pinouts (RJ45)
 - Serial Port Pinouts (Male DB9)
 - DIO Pin Headers
 - LED Indicators

NE-4000T Module

The NE-4000T module is a serial (TTL) to Ethernet embedded enabler that is small enough to fit inside most serial devices. Serial device manufacturers use the module to upgrade existing serial devices into products that can be connected directly to an Ethernet port.

Panel Layout

Top panel of NE-4000T

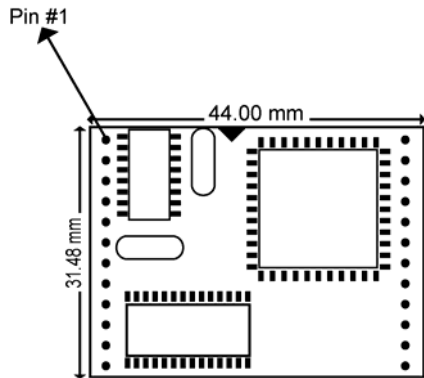

Side panel of NE-4000T

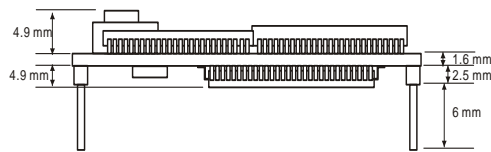

Back panel of NE-4000T

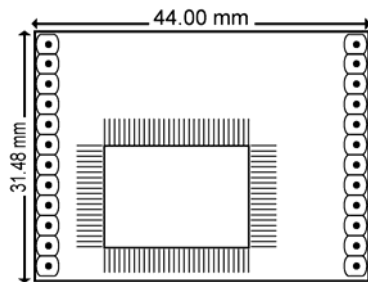

Pin Assignments

Pin	Signal
1	ETx+
2	ETx-
3	ERx+
4	ERx-
5	Link/Active LED
6	TXD
7	RXD
8	RTS
9	CTS
10	Reserved
11	GND
12	GND

Pin	Signal
13	DIO0
14	DIO1
15	DIO2
16	DIO3
17	DIO4
18	DIO5
19	DIO6
20	DIO7
21	Reserved
22	Ready LED
23	+5V
24	+5V

NOTE Ethernet Signals: ETx+, ETx-, ERx+, ERx-
 Serial Signals: TXD, RXD, RTS, CTS
 LED Names: Link/Active, Ready

Block Diagram

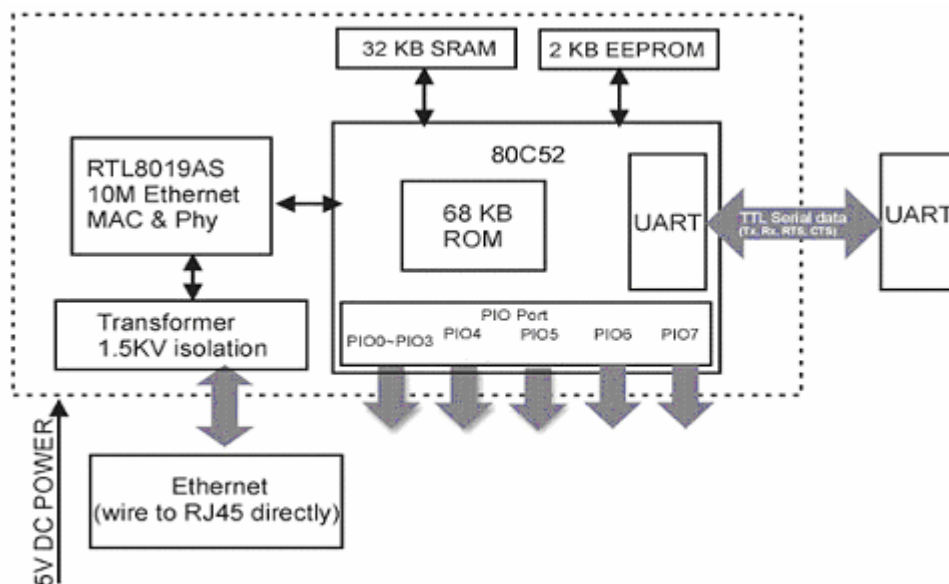

NE-4000T-ST Starter Kit

The NE-4000T-ST Starter Kit is used to evaluate the NE-4000T module and to develop applications. The Starter Kit has a serial port and Ethernet port that provide a direct connection between a PC and the NE-4000T module. The dimensions of the board are 130 × 50 mm (W × D), with a thickness of 1.6 mm.

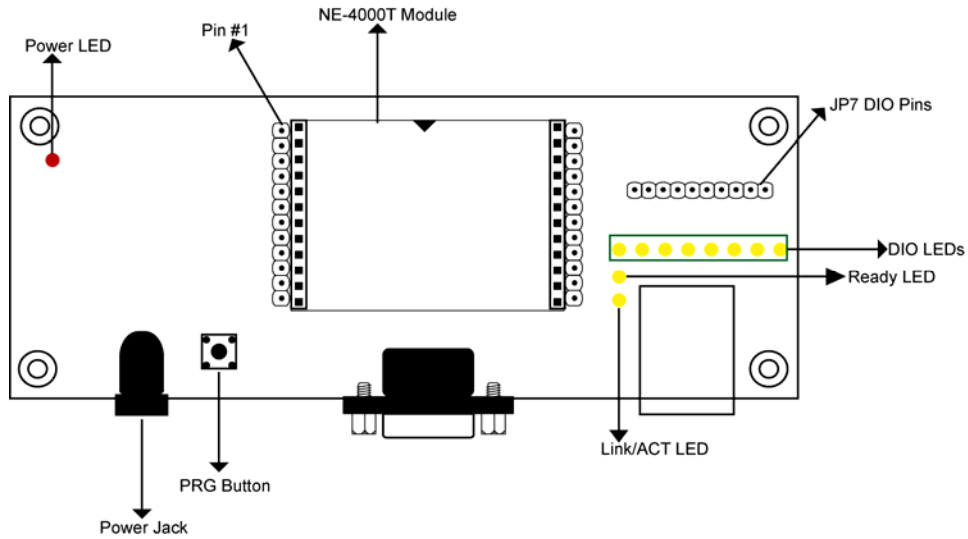

Ethernet Port Pinouts (RJ45)

Pin	Signal
1	Tx+
2	Tx-
3	Rx+
6	Rx-

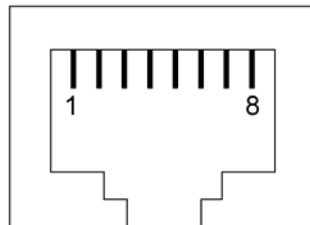

Serial Port Pinouts (Male DB9)

Pin	Signal
1	DCD
2	RXD
3	TXD
4	DTR
5	GND
6	DSR
7	RTS
8	CTS

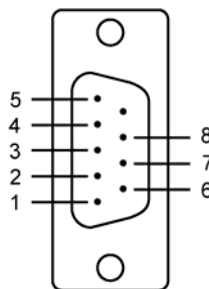

DIO Pin Headers

Pin	Signal	
1	VCC	• VCC
2	PIO0	• PIO0
3	PIO1	• PIO1
4	PIO2	• PIO2
5	PIO3	• PIO3
6	PIO4	• PIO4
7	PIO5	• PIO5
8	PIO6	• PIO6
9	PIO7	• PIO7
10	GND	• GND

LED Indicators

LED Name	LED Color	LED Function
Power	red	Indicates that the power is on.
Ready	green	Steady on: Power is on and NE-4000T-ST is functioning normally. Blinking: NE-4000T is in DHCP Client mode, but it cannot find the DHCP Server.
	off	Power is off, or power error condition exists.
Link	green	10 Mbps Ethernet connection.
	off	Ethernet cable is disconnected, or has a short.
DIO0	green	Indicates that DIO is in "low" (0) status.
DIO1	green	Indicates that DIO is in "low" (0) status.
DIO2	green	Indicates that DIO is in "low" (0) status.
DIO3	green	Indicates that DIO is in "low" (0) status.
DIO4	green	Indicates that DIO is in "low" (0) status.
DIO5	green	Indicates that DIO is in "low" (0) status.
DIO6	green	Indicates that DIO is in "low" (0) status.
DIO7	green	Indicates that DIO is in "low" (0) status.

3

Getting Started

In this chapter, we explain how to set up the NE-4000T module and NE-4000T-ST Start Kit, and briefly describe the operation modes for each of the four NE-4000T models.

This chapter covers the following topics:

- ❑ **Wiring Requirements**
- ❑ **Plugging NE-4000T into NE-4000T-ST**
- ❑ **Connecting the Power**
- ❑ **Connecting to the Network**
- ❑ **Connecting to a Serial Device**
- ❑ **DI/O Settings**
 - Digital Output
 - Digital Input
 - Digital Output LED Circuit Design
- ❑ **Operating Modes**
 - Real COM Mode (NE-4000T-RC)
 - TCP Server Mode (NE-4000T-TS)
 - TCP Client Mode (NE-4000T-TC)
 - UDP Mode (NE-4000T-UD)

Wiring Requirements

You should heed the following common safety precautions before proceeding with the installation of any electronic device:

- Use separate paths to route wiring for power and devices. If power wiring and device wiring paths must cross, make sure the wires are perpendicular at the intersection point.

NOTE: Do not run signal or communication wiring and power wiring in the same wire conduit. To avoid interference, wires with different signal characteristics should be routed separately.

- Use the type of signal transmitted through a wire to determine which wires should be kept separate. The rule of thumb is that wiring that shares similar electrical characteristics can be bundled together.
- Keep input wiring and output wiring separate.
- It is advisable to label the wiring to all devices in the system.



ATTENTION

Safety First!

Be sure to disconnect the power cord before installing and/or wiring your NE-4000T-ST.

Wiring Caution!

Calculate the maximum possible current in each power wire and common wire. Observe all electrical codes dictating the maximum current allowable for each wire size.

If the current goes above the maximum ratings, the wiring could overheat, causing serious damage to your equipment.

Temperature Caution!

Be careful when handling NE-4000T-ST. When plugged in, NE-4000T-ST's internal components generate heat, and consequently the board may feel hot to the touch.

Plugging NE-4000T into NE-4000T-ST

Before you connect NE-4000T-ST to the power supply, network, and serial device, you first need to plug the NE-4000T module into the NE-4000T-ST board. Both the module and board are clearly marked with white triangles that indicate how to position NE-4000T before plugging it in. In the center of NE-4000T-ST, there is a square with one white inverted triangle (shown as black in the figure) on one of its sides, and 2 rows of female sockets on the other two sides. The NE-4000T board also has a white inverted triangle (shown as black in the figure) on one of its sides. When plugging your NE-4000T into the NE-4000T-ST board, make sure these 2 white inverted triangles are facing the same direction, as shown in the figure.

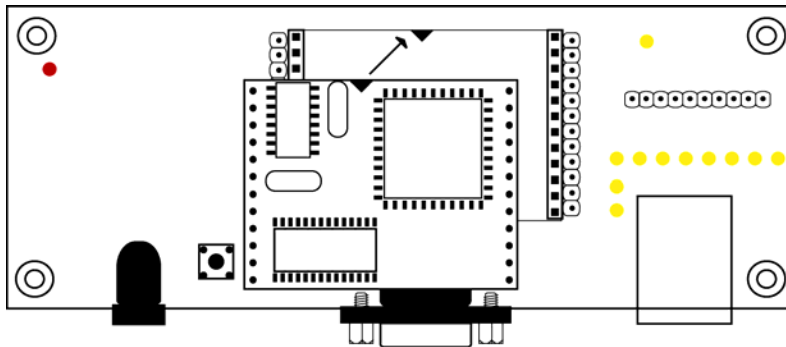

Connecting the Power

Connect the 12-30 VDC power line to NE-4000T-ST's terminal block. If the power cord is properly connected, the "POWER" LED will illuminate in red. When the system boots up and is ready to go, the "Ready" LED will illuminate in green.

Connecting to the Network

Connect one end of the Ethernet Cable to NE-4000T-ST's Ethernet port and the other end of the cable to the Ethernet network. If the cable is properly connected, NE-4000T-ST will indicate a valid connection to the Ethernet in the following ways:

- The Link LED will maintain a solid green color when connected to a 10 Mbps Ethernet network.
- The Link LED will flicker when Ethernet packets are being transmitted or received.

Connecting to a Serial Device

Use a serial data cable to connect a serial device to the NE-4000T-ST board when testing and developing applications. NE-4000T-ST's serial port also serves as a serial console port. You may find it convenient to use the serial console utility during the production stage to configure a large number of NE-4000T modules before installing the modules in the serial device.

D/I/O Settings

NE-4000T Embedded Network Enabler supports 8 Digital I/Os.

Digital Output

Each Digital Output uses 2 signals to control the devices connected to the terminal block on the evaluation board (NE-4000T-ST), such as relay devices. The 2 signals are formed by changes between high and low voltages. For example, you can program DO \emptyset to maintain a "high voltage" (in this case, the DO \emptyset 's LED will not light up), and change to "low voltage" (in this case, the DO \emptyset 's LED will light up) when you wish to trigger the relay device. By using these 2 output signals, you can control the on/off status of your devices.

Digital Input

Each Digital Input also uses the 2 signals mentioned above to recognize the messages coming from your device, such as a sensor. Unlike Digital Output mode, NE-4000T waits passively for incoming signals when set to Digital Input mode. For example, you can configure DIØ to be in the “On” state, meaning no signal is coming in, when in the “low voltage” state. With this type of setup, the state will change to “high voltage” when a signal is coming in. Use the Network Enabler Administrator, discussed in Chapter 4, to configure the DI/O and on/off status.

Digital Output LED Circuit Design

The figure shown below represents the digital output LED circuit. This type of design is called a “Sink.”



When you develop your own applications, you will need to follow the voltage limits shown below.

		Min.	Max.	Unit
Low-level Input Voltage	Maximum voltage when DI is set to “Low” status.	-----	0.3xVCC	V
High-level Input Voltage	Minimum voltage when DI is set to “High” status.	0.7xVCC	-----	V
Low-level Input Voltage	Maximum voltage when DO is set to “Low” status.	-----	0.4	V
High-level Input Voltage	Minimum voltage when DO is set to “High” status	2.4	-----	V

The Digital Output carries a current of only 1 mA.

Operating Modes

Each of the four NE-4000T models supports a different operation mode. NE-4000T-RC supports Real COM Mode, NE-4000T-TS supports TCP Server Mode, NE-4000T-TC supports TCP Client Mode, and NE-4000T-UD supports UDP Mode. The four operation modes are described separately in the following subsections. Note that the main difference between the TCP and UDP protocols is that TCP *guarantees* delivery of data by requiring the recipient to send an acknowledgement to the sender. UDP does not require this type of verification, making it possible to offer speedier delivery. UDP also allows multicasting of data to groups of IP addresses.

Please note that the module’s operating mode cannot be changed by updating the firmware. Please verify the desired operating mode for your NE-4000T when ordering.

Real COM Mode (NE-4000T-RC)

NE-4000T-RC comes equipped with COM drivers that work with Windows 95/98/ME/NT/2000/XP systems. The driver establishes a transparent connection between host and serial device by mapping the IP:Port of the NE-4000T-RC's serial port to a local COM port on the host computer.

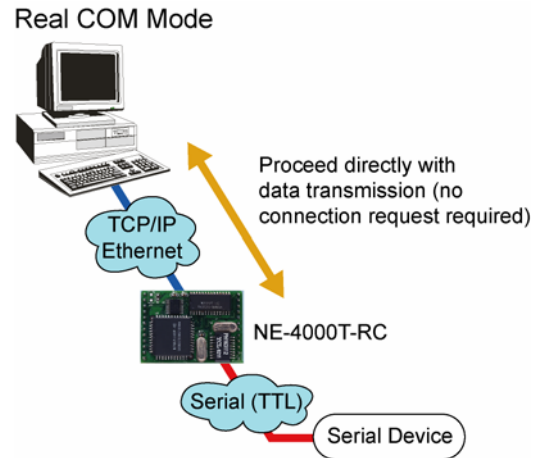

The important point about Real COM Mode is that it allows users to continue using RS-232 serial communications software that was written for pure serial communications applications. The driver intercepts data sent to the host's COM port, packs it into a TCP/IP packet, and then redirects it through the host's Ethernet card. At the other end of the connection, the NE-4000T-RC accepts the Ethernet frame, unpacks the TCP/IP packet, and then transparently sends it to the appropriate serial device.

TCP Server Mode (NE-4000T-TS)

NE-4000T-TS uses TCP Server mode to establish the Serial-to-Ethernet connection. NE-4000T-TS provides a unique IP:Port address on a TCP/IP network. NE-4000T-TS waits passively to be contacted by the host computer, allowing the host to establish a connection with the serial device. Data transmission proceeds as illustrated below.

1. The host requests a connection from the NE-4000T-TS configured for TCP Server Mode.
2. Once the connection is established, data can be transmitted in both directions— from the host to the NE-4000T-TS, and from the NE-4000T-TS to the host.

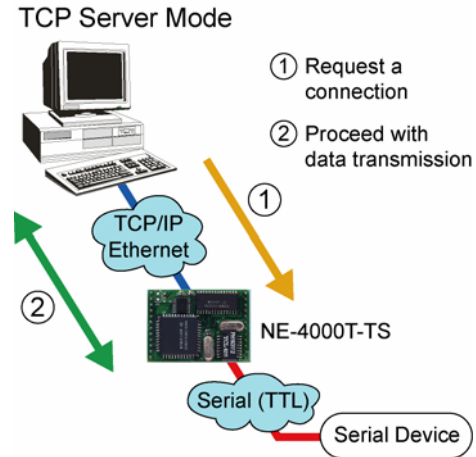

TCP Client Mode (NE-4000T-TC)

In TCP Client mode, NE-4000T-TC can actively establish a TCP connection to a pre-defined host computer when serial data arrives.

After the data has been transferred, NE-4000T-TC can disconnect automatically from the host computer by using the **TCP alive check time** or **Inactivity time** settings. Refer to Chapter 4 for more details

As illustrated in the figure, data transmission proceeds as follows:

1. The NE-4000T-TC requests a connection to the host.
2. Once the connection is established, data can be transmitted in both directions—from the host to the NE-4000T-TC, and from the NE-4000T-TC to the host.

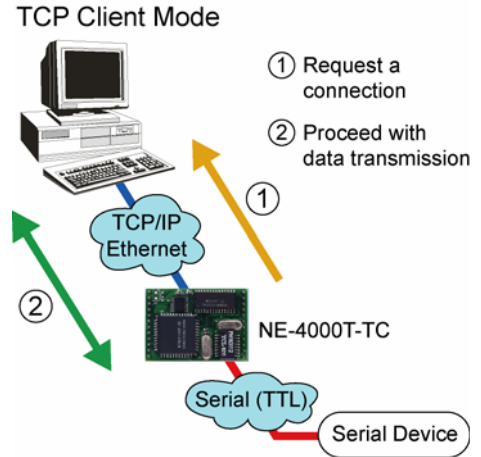

UDP Mode (NE-4000T-UD)

Compared to TCP communication, UDP is faster and more efficient. In UDP mode, you can unicast or multicast data from the serial device to one or more host computers. The serial device can also receive data from multiple host computers, making this mode ideal for message display applications.

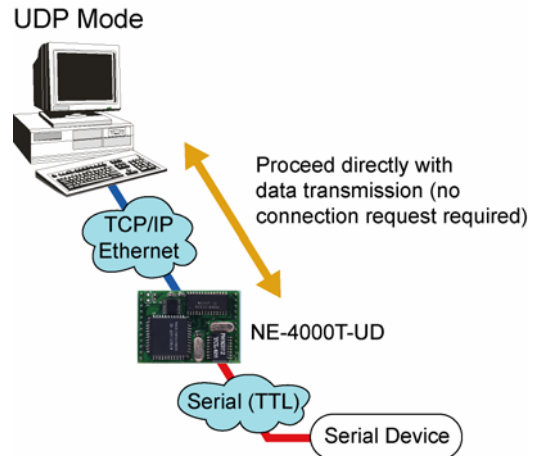

Network Enabler Administrator

In this chapter, we demonstrate how to use Network Enabler Administrator to configure your NE-4000T. Unless otherwise noted, the Real COM model (NE-4000T-RC) is used to illustrate how to install and configure NE-4000T.

This chapter covers the following topics:

- ❑ **Installing Network Enabler Administrator**
- ❑ **Configuration window**
- ❑ **Broadcast Search**
- ❑ **Specify by IP Address**
- ❑ **NE-4000T Configuration Information**
 - Status Settings
 - Unlock Password Protection
- ❑ **Configuring NE-4000T**
 - Basic
 - Network
 - Serial
 - Operating Mode
 - Accessible IPs
 - Password
 - Digital I/O
 - Export/Import Functions

Installing Network Enabler Administrator

In this section, we describe how to install Network Enabler Administrator.

1. Insert the CD that comes with NE-4000T into your computer's CD-ROM drive. If your computer is not set up to autorun, click on the utility_setup icon to start the installation.

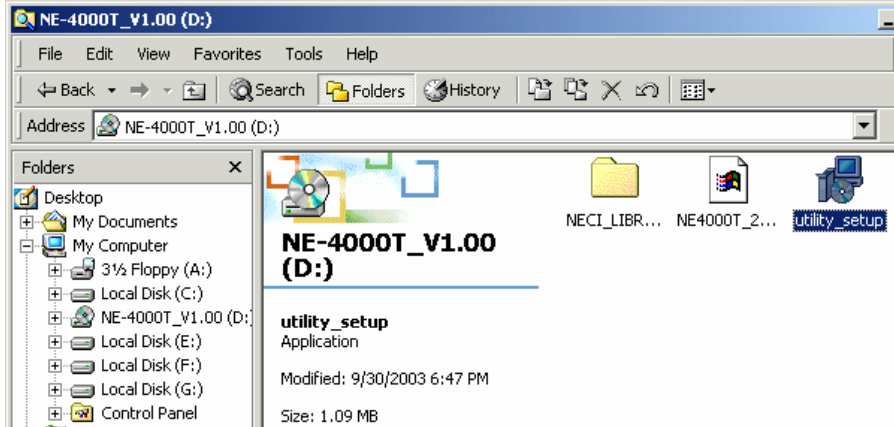

2. Click on **Yes** to continue.

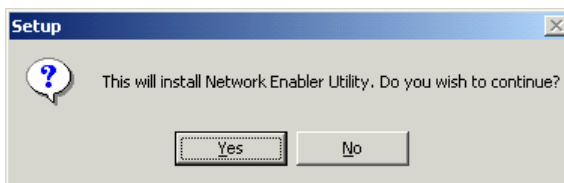

3. The **Welcome to the Network Enabler Administrator 2.6 Setup Wizard** window opens next. Click on **Next** to continue.

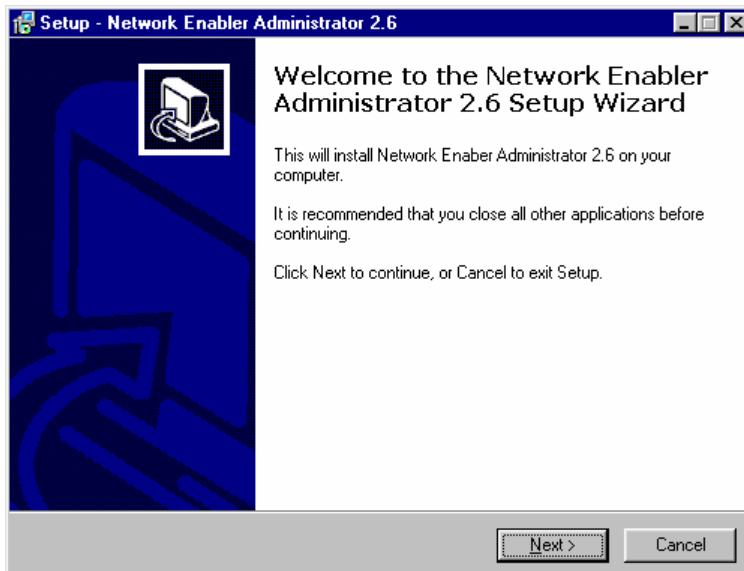

4. Accept the default destination folder, or select an alternative. Click on **Next** to continue.

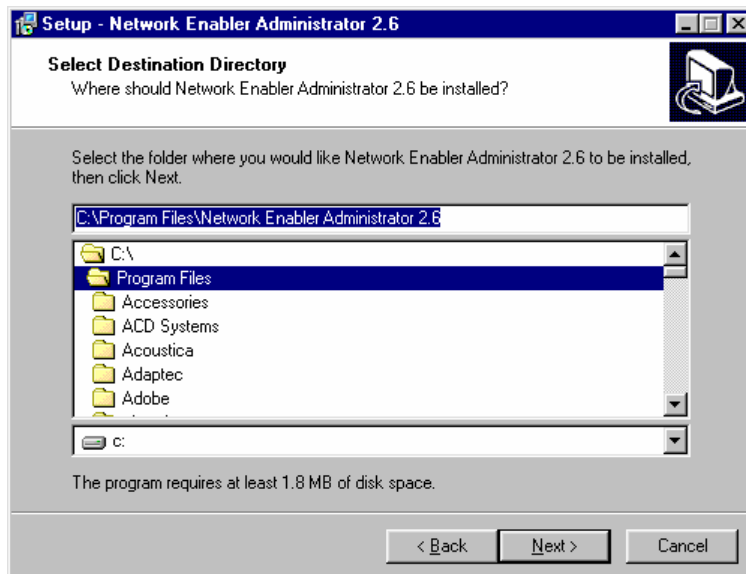

5. Check the **Create a desktop icon** box if you would like the Network Enabler Administrator icon to appear on your desktop. Click on **Next** to continue.

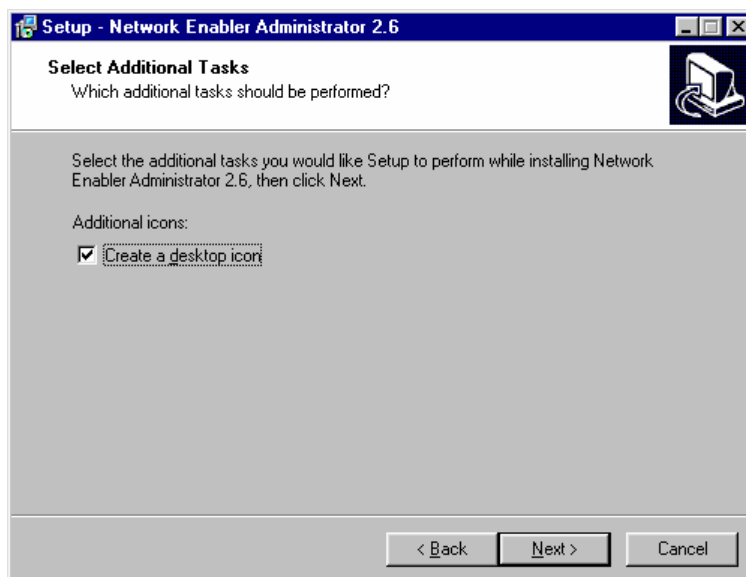

6. Confirm that the **Destination directory** and **Additional tasks** are correct, and then click on **Install** to continue. Click on **Back** to make modifications.

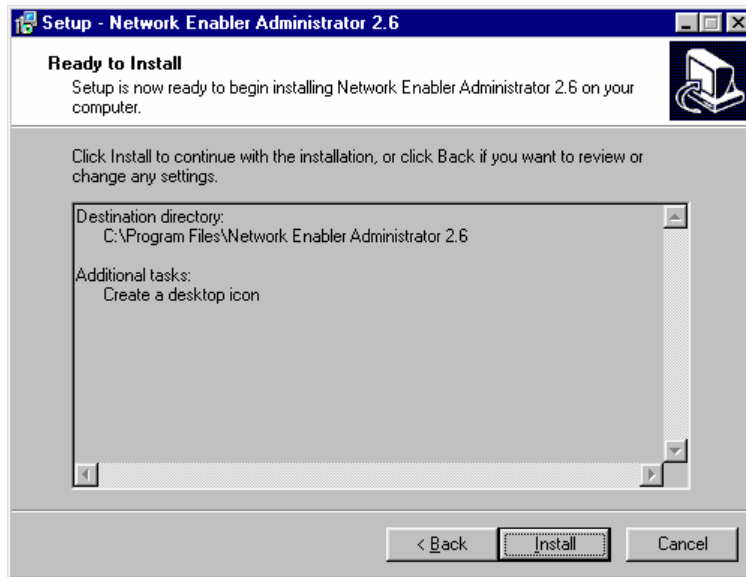

7. The **Installing** window shows that setup files are being copied to your computer.

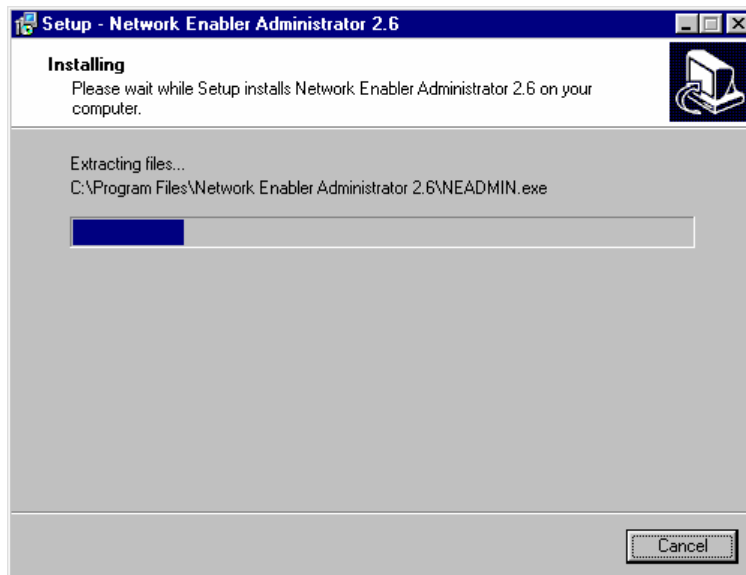

8. Check the **Launch Network Enabler Administrator** box if you would like to start Network Enabler Administrator right away, and then click on **Finish**.

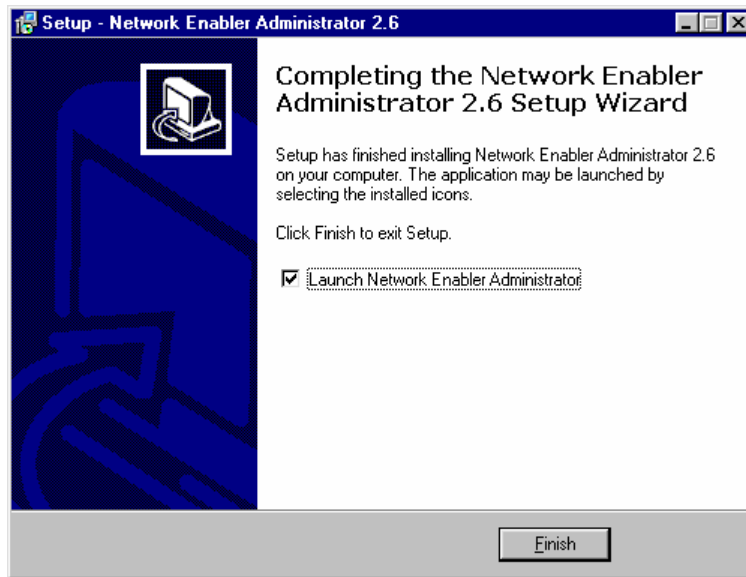

Configuration Window

To start Network Enabler Administrator, select **Start → Programs → Network Enabler Administrator 2.6 → Network Enabler Administrator**, or click on the **Network Enabler Administrator 2.6** icon on your desktop.



Network Enabler Administrator opens to the Configuration window, which is divided into four sections:

- The top section of the window includes the menu bar and function icons.
- The left-middle section of the window allows you to choose between **Configuration** mode and **COM Mapping** mode.
- The right-middle section of the window shows the NE-400T units with which Network Enabler Administrator has established contact. Use this list to select the units you would like to configure.
- The bottom section of the window is the **Message Log** section. Note that the log is erased each time Network Enabler Administrator is shut down.

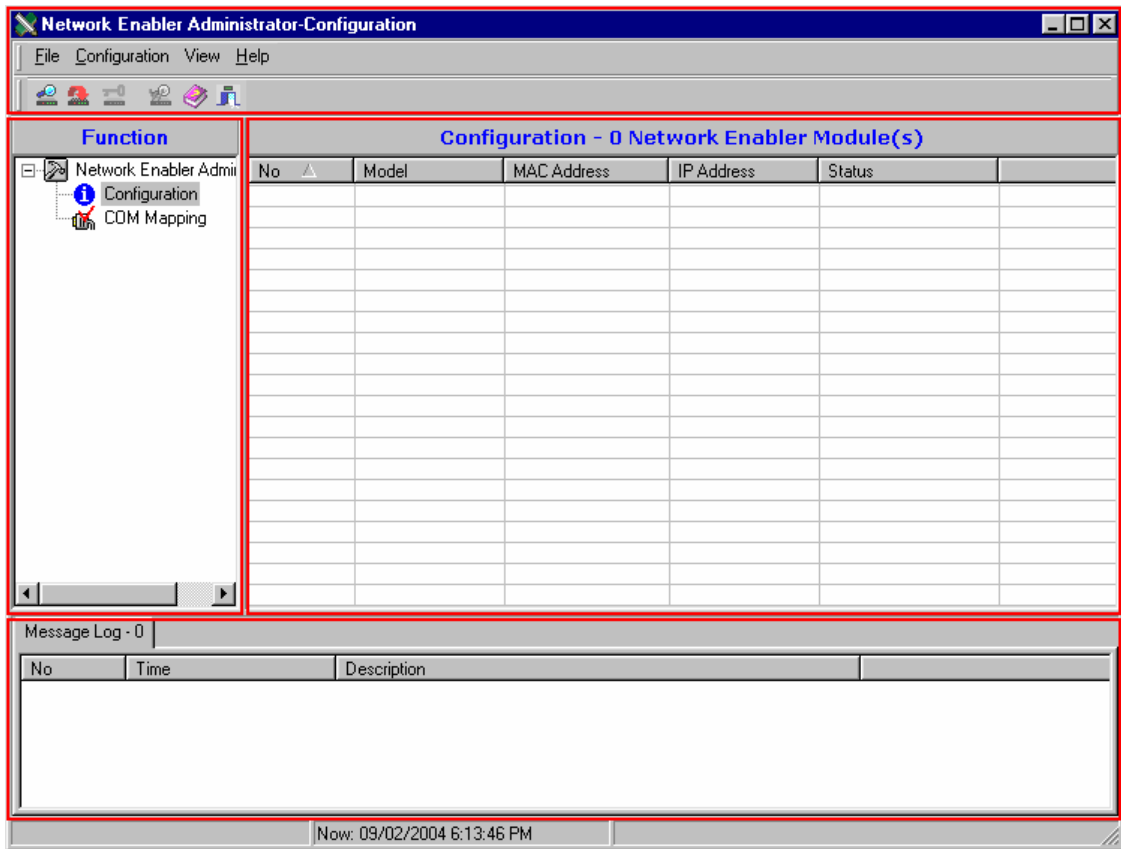

Broadcast Search

Broadcast Search searches by MAC address to locate all NE-4000T units connected to the same Ethernet LAN as your PC. This means that Broadcast Search locates all NE-4000T units connected to the same Ethernet LAN as your PC, regardless of whether or not the NE-4000T units are part of the same subnet as the PC.

1. To start searching, select **Broadcast Search** from the **Configuration** menu.

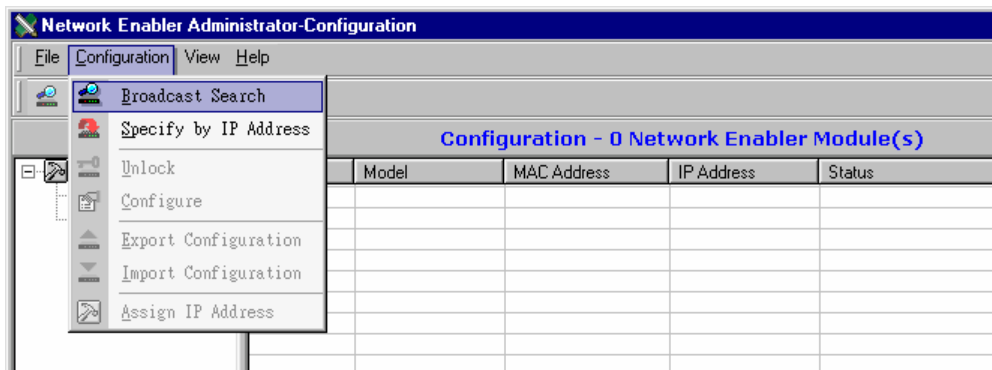

2. The **Searching** window shows the Model, MAC Address, and IP Address of the NE-4000T units that have been located. Click on **Stop** if the unit you are searching for is already listed.

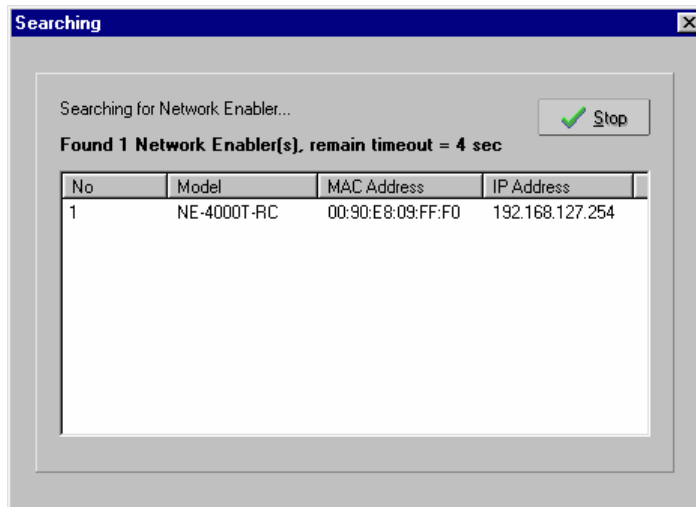

- The **Configurator** window lists all NE-4000T units that were located.

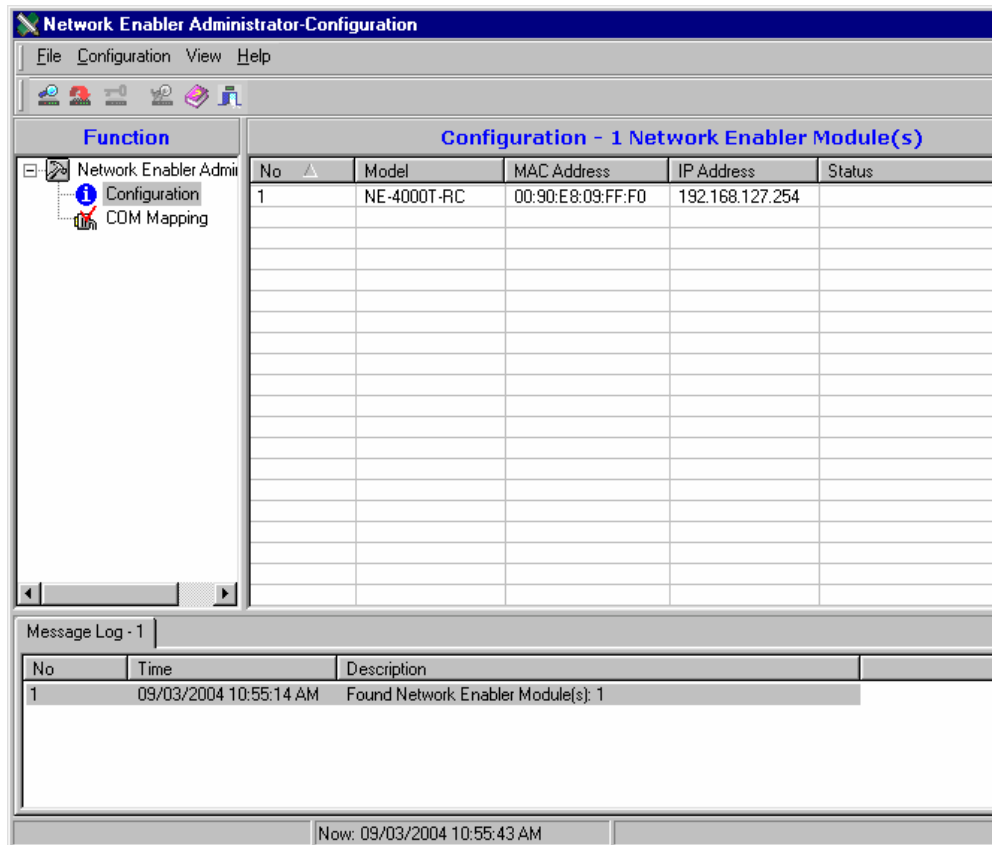

Specify by IP Address

- Select **Specify by IP address** under the **Configuration** menu to locate NE-4000T units by IP address. This function can be used to find NE-4000T units located anywhere in the world, provided the unit is accessible from the Internet.

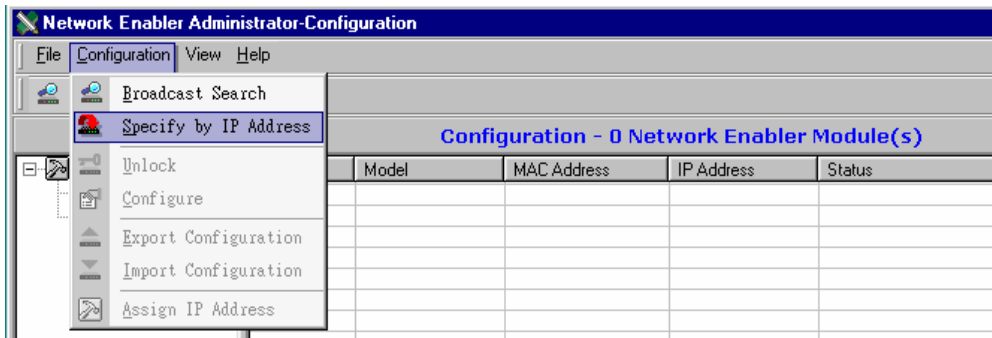

2. Type the IP address of the NE-4000T in the **Input a Network Enabler IP address** text field, and then click on **OK**.

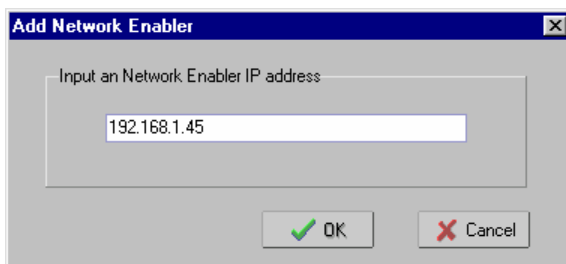

3. The NE-4000T will be listed in the **Configuration** window if Network Enabler Administrator was able to locate the unit by IP address.

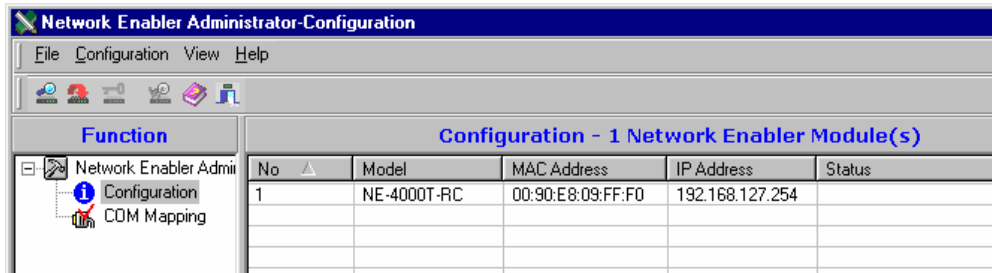

ATTENTION

Use **Broadcast Search** or **Specify by IP Address** to locate NE-4000T units.

- **Broadcast Search** uses MAC address to locate all NE-4000T units connected to the same Ethernet LAN as the PC used to conduct the search.
- **Specify by IP Address** can be used to locate any NE-4000T unit that is accessible from the PC used to conduct the search.

Note that in some circumstances, you will not be able to use Specify by IP Address to locate an NE-4000T unit connected to the same LAN as the PC used to conduct the search. For example, suppose your PC and NE-4000T are connected to the same Ethernet LAN, but are assigned to different subnets. If you do not configure a valid Gateway IP, then Specify by IP Address will report that the unit cannot be found. In this case, use Broadcast Search to find the NE-4000T unit.

NE-4000T Configuration Information

Configuration - 1 Network Enabler Module(s)				
No	Model	MAC Address	IP Address	Status
1	NE-4000T-RC	00:90:E8:09:FF:F0	192.168.127.254	

Five items are listed in the Configuration window:

No

The order in which the NE-4000T units were located.

Model

The model name—NE-4000T-RC, NE-4000T-TS, NE-4000T-TC, or NE-4000T-UD.

MAC Address

The unique MAC Address assigned by Moxa. The MAC address cannot be modified.

IP Address

The NE-4000T unit's current IP address.

Status

Lock, Unlock, *Blank*, Fixed, Lock Fixed, Unlock Fixed (see the following subsection for details).

Status Settings

There are six **Status** settings (note that the term Fixed is borrowed from the standard fixed IP address networking terminology):

Lock

The NE-4000T is password protected, "Broadcast Search" was used to locate it, and the password has not been entered during the current Administrator session.

Unlock

The NE-4000T is password protected, "Broadcast Search" was used to locate it, and the password was used to unlock the unit. During the current Administrator session, activating various utilities for this NE-4000T will not require re-entering the unit's password.

Blank

The NE-4000T is not password protected, and "Broadcast Search" was used to locate it.

Fixed

The NE-4000T is not password protected, and "Search by IP address" was used to locate it.

Lock Fixed

The NE-4000T is password protected, "Specify by IP address" was used to locate it, and the password has not been entered during the current Administrator session.

Unlock Fixed

The NE-4000T is password protected, "Specify by IP address" was used to locate it, and the password was used to unlock the unit. During the current Administrator session, activating various utilities for this NE-4000T will not require re-entering the unit's password.

Unlock Password Protection

NE-4000T units listed with **Status** of **Lock** or **Lock Fixed** are password protected. If you attempt to modify the NE-4000T unit's configuration by double clicking on the unit's name, the Error message **Target is password protected. You must [Unlock] first.** will appear.

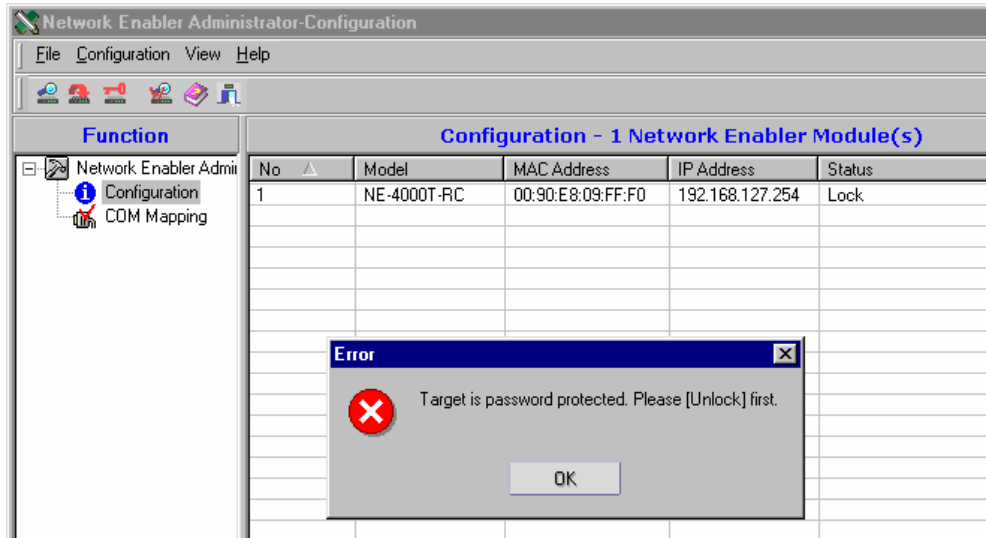

To unlock the NE-4000T unit:

1. Select the NE-4000T that you would like to unlock, and then click the right mouse button. Select **Unlock** from the drop down list.

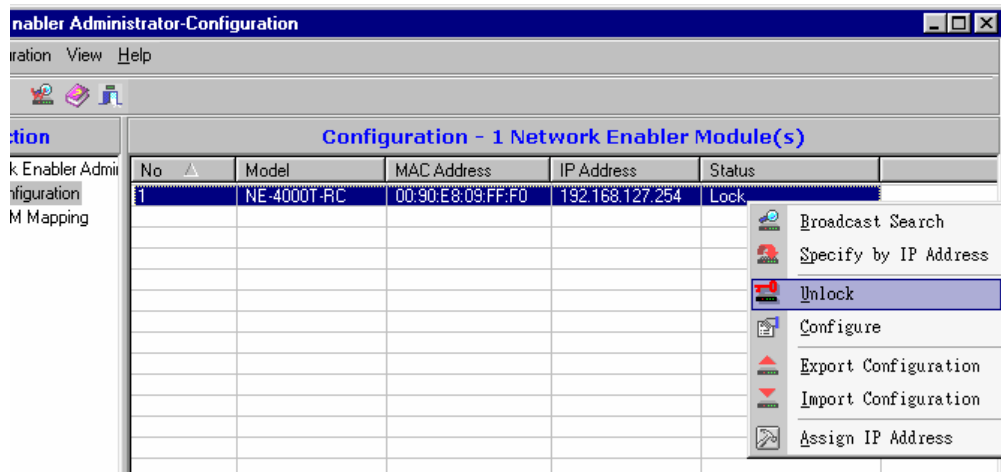

2. Type in the password and then click on **OK**.

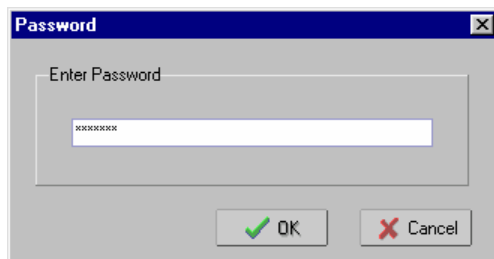

- If you entered the correct password, click on **OK** in the **Unlock ok** window.



- The NE-4000T unit will be listed as **Unlock** or **Unlock Fixed**, depending on whether you used “Broadcast Search” or “Search by IP address” to locate the unit.

Configuring NE-4000T

- Select the NE-4000T you wish to configure to highlight it, click the right mouse button, and then select **Configure** from the drop down list.

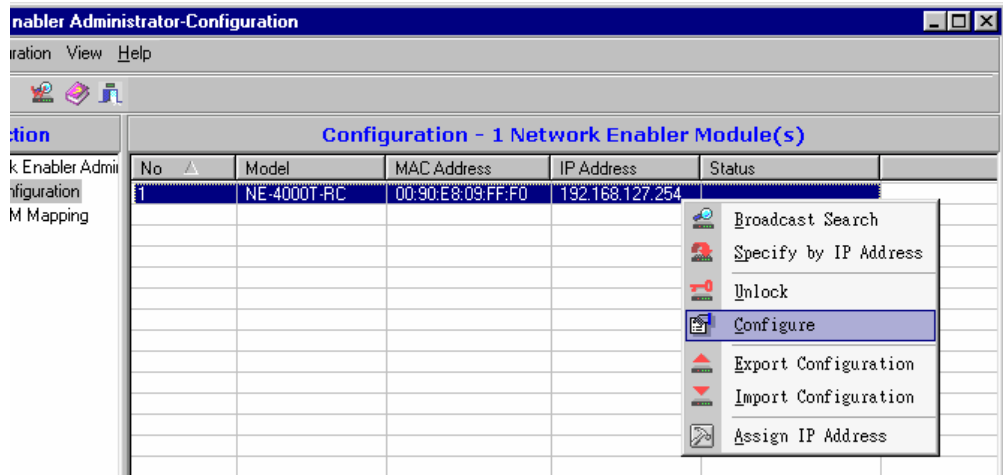

- The **Processing** window opens.

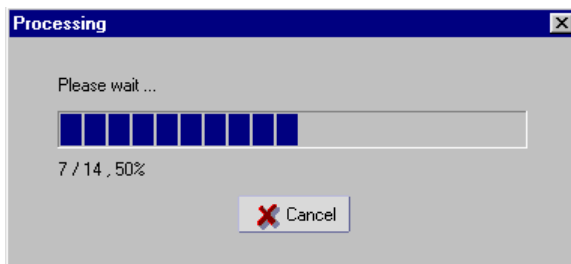

- 3. After all items have been processed, the **Configuration** window opens.

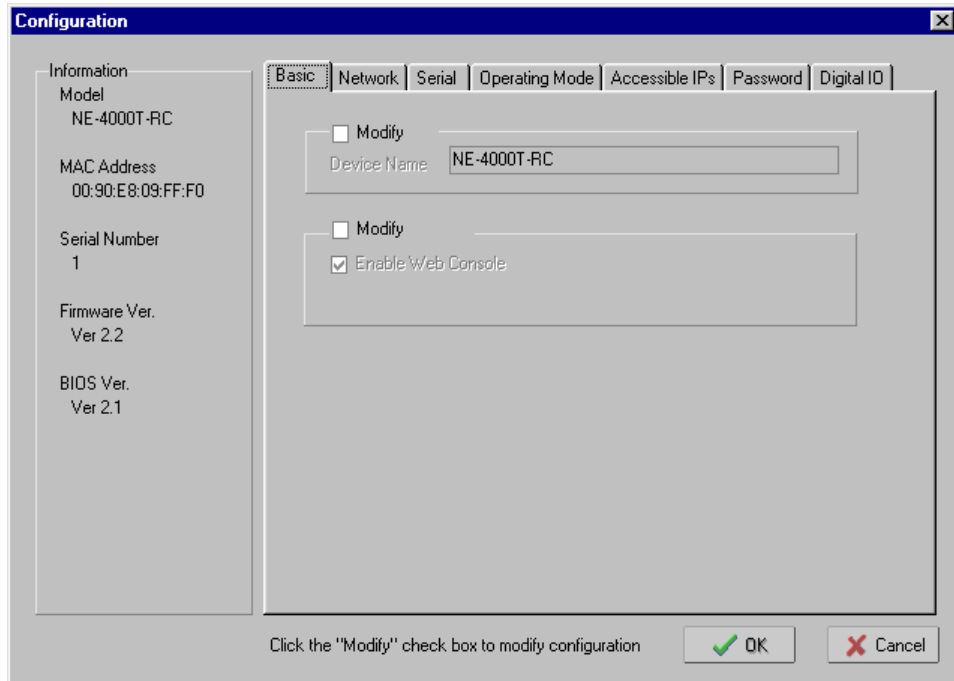

The Configurator window has seven tabs—**Basic**, **Network**, **Serial**, **Operating Mode**, **Accessible IPs**, **Password**, and **Digital I/O**—that allow the user to view and modify settings.

Basic

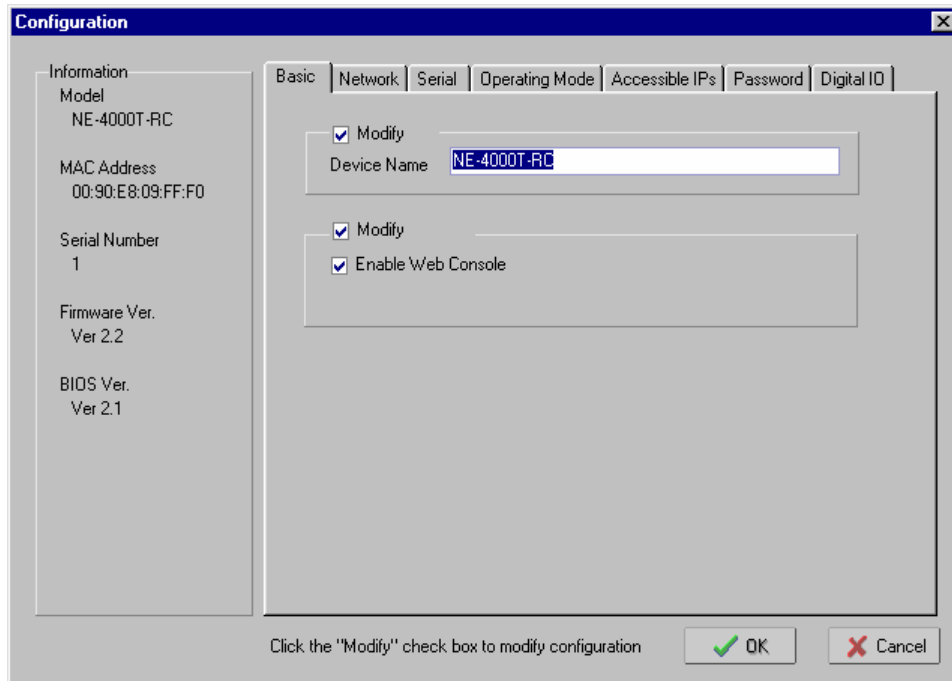

Device Name

Setting	Factory Default	Necessity
1 to 15 characters	NE-4000T-MN (MN = RC, TS, TC, or UD)	Optional

To change the **Device Name**, check the **Modify** box above Device Name, and then type the new name in the text input box. This option is useful for specifying the location or application of different NE-4000T units.

Enable Web Console

Setting	Factory Default	Necessity
Enable or Disable	Enable	N/A

To disable the Web Console, check the **Modify** box located above Enable Web Console, and then un-check the box to the left of **Enable Web Console**. If this option is *disabled*, you will not be able to open the NE-4000T unit's web page from a web browser. You may want to *disable* this feature as an extra precaution to prevent unauthorized users from accessing your NE-4000T.

Note that NE-4000T also has a **Serial Console**, which is always active. The Serial Console can only be accessed via the NE-4000T-ST Starter Kit.

Network

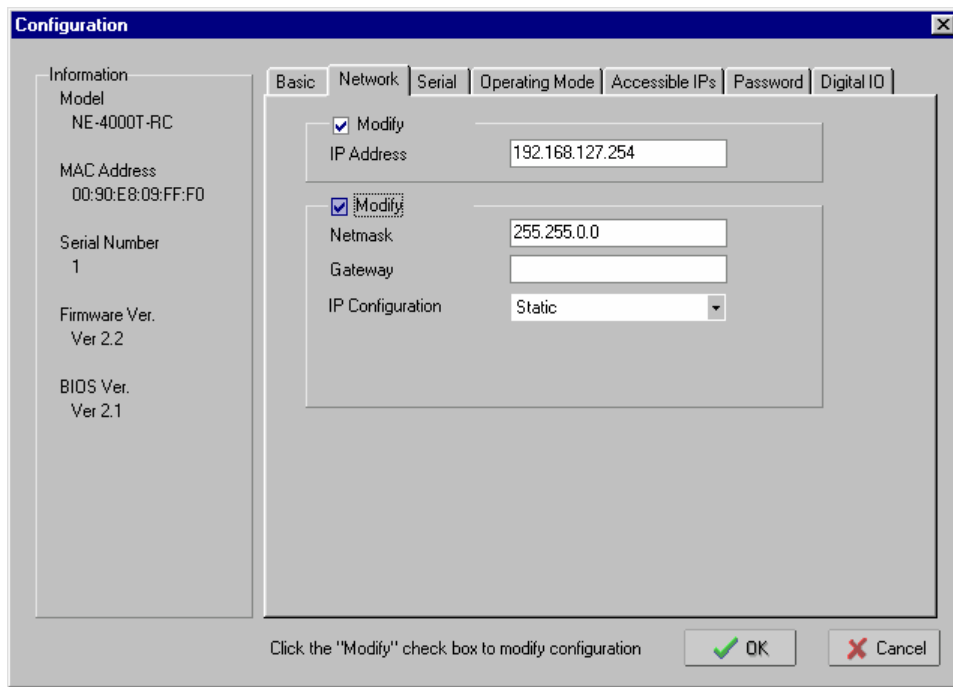

IP Address

Setting	Factory Default	Necessity
xxx.xxx.xxx.xxx (e.g., 192.168.1.1; IP addresses of the form x.x.x.0 and x.x.x.255 are invalid.)	192.168.127.254	Required

To change the **IP address**, check the **Modify** box located above **IP Address**, and then enter the assigned IP address. An IP address is a number assigned to a network device (such as a computer) as a permanent address on the network. Computers use the IP address to identify and talk to each other over the network. Choose a proper IP address that is unique and valid in your network environment.

Netmask

Setting	Factory Default	Necessity
xxx.xxx.xxx.xxx (e.g., 255.255.255.0)	255.255.0.0	Required

To change the **Netmask**, check the **Modify** box located above **Netmask**, and then enter the new setting. Note that by default, NE-4000T is assigned to a Class B subnet.

The netmask is used to group network hosts into a particular subnet. When a packet is sent out over the network, the NE-4000T will use the netmask to check whether the desired TCP/IP host specified in the packet is on the subnetwork. If the address is on the same subnet as the NE-4000T, a connection is established directly from the NE-4000T. Otherwise, the packet is sent to the Gateway address.

Gateway

Setting	Factory Default	Necessity
e.g., 192.168.1.1	None	Optional

To change the **Gateway**, check the **Modify** box located above **Netmask**, and then enter the new setting.

A gateway is usually a router that links the subnet to a larger network. Typically, the computers that control traffic within the network or at the local Internet service provider are gateway nodes. NE-4000T needs to know the IP address of the default gateway computer in order to communicate with the hosts outside the local network environment. Contact your network administrator to get the correct gateway IP address for your NE-4000T.

IP Configuration

Setting	Factory Default	Necessity
Static or DHCP	Static	N/A

To change the **IP Configuration**, check the **Modify** box located above **Netmask**, and then select the desired setting from the drop-down box.

When the DHCP option is selected, NE-4000T will search for a DHCP server by transmitting DHCP broadcast packets over the network. If a DHCP server is located, NE-4000T will automatically update IP Address, Netmask, and Gateway to the values provided by the DHCP server. If a DHCP server is not located within 1 minute, NE-4000T will configure the network settings to the default values. If the IP address changes, you will need to conduct a new Broadcast Search to locate the NE-4000T.

Serial

Select the NE-4000T that you would like to modify, check the **Modify** box, and then click on the **Settings** button in the lower right corner of the window.

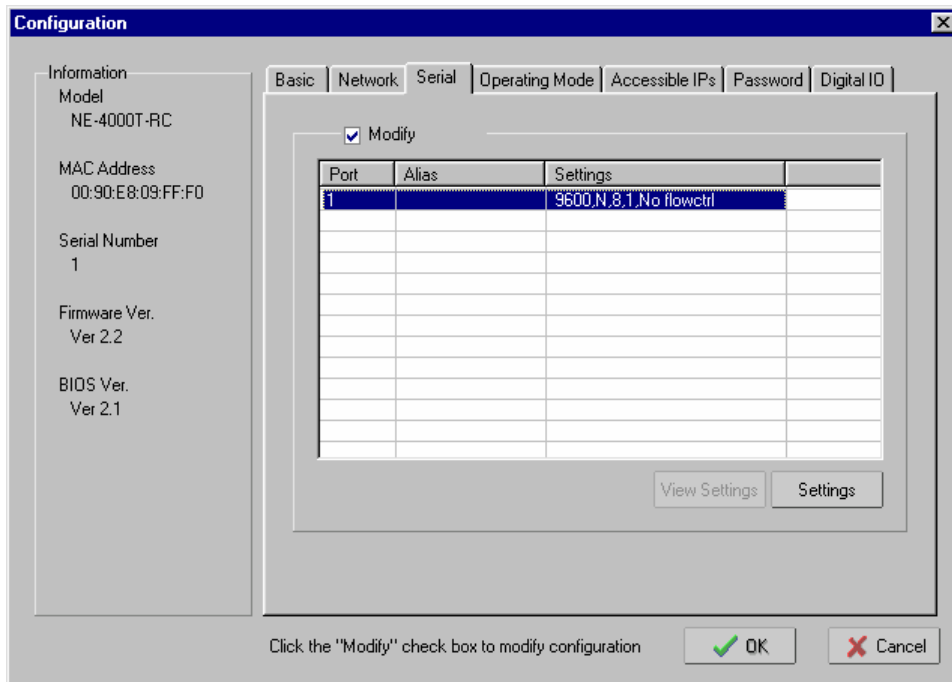

The **Serial Settings** window will open, allowing you to make changes to the serial parameters.

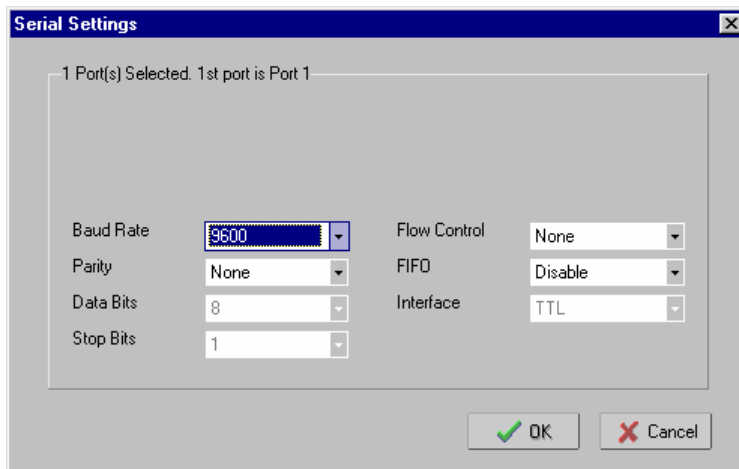

Baud Rate

Setting	Factory Default	Necessity
300 bps to 115.2 Kbps	9600 bps	N/A

Parity

Setting	Factory Default	Necessity
None, Odd, Even	None	N/A

Data Bits

Setting	Factory Default	Necessity
8	8	N/A

Stop Bits

Setting	Factory Default	Necessity
1	1	N/A

Flow Control

Setting	Factory Default	Necessity
None, RTS/CTS, XON/XOFF	None	N/A

FIFO

Setting	Factory Default	Necessity
Disable	Disable	N/A

Interface

Setting	Factory Default	Necessity
TTL	TTL	N/A

**ATTENTION**

Check the serial communication parameters in your Serial Device's user's manual, and then configure NE-4000T's serial parameters with the same communication parameters used by your serial devices.

Operating Mode

Since the configuration variables depend on the Operating Mode, we discuss each NE-4000T model separately.

Real Com Mode

Check the **Modify** box, select the NE-4000T-RC you would like to configure, and then click on the **Settings** button in the lower right corner of the window.

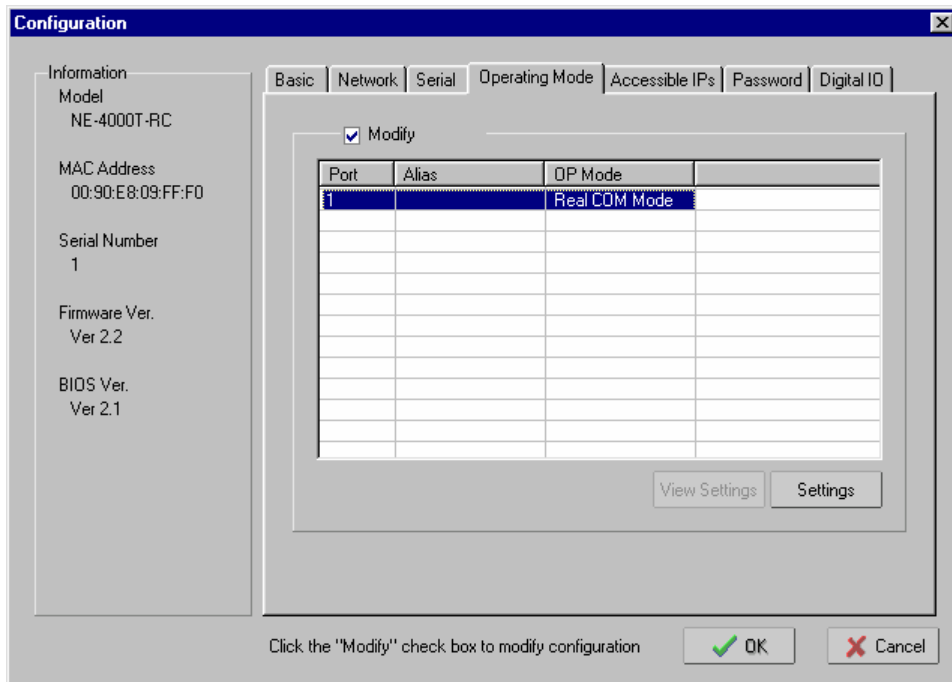

The Real COM configuration panel will open.

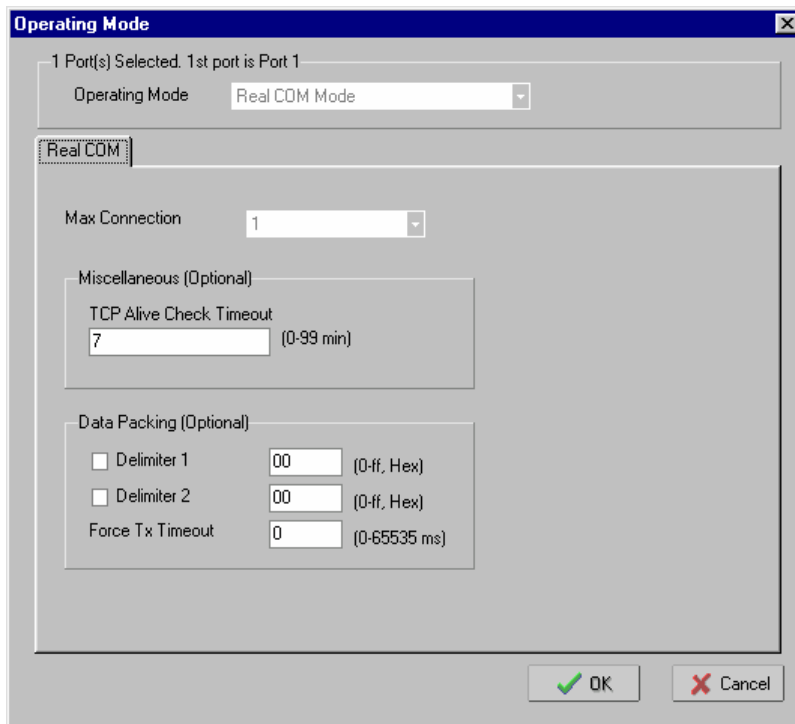

TCP Alive Check Timeout

Setting	Factory Default	Necessity
0 to 99 min	7 min	Optional

0 min: TCP connection is not closed due to an idle TCP connection.

1 to 99 min: NE-4000T-RC automatically closes the TCP connection if there is no TCP activity for the given time. After the connection is closed, NE-4000T-RC starts listening for another connection request.

Delimiter 1

Setting	Factory Default	Necessity
00 to FF	None	Optional

Delimiter 2

Setting	Factory Default	Necessity
00 to FF	None	Optional

Force Tx Timeout

Setting	Factory Default	Necessity
0 to 65535 ms	0	Optional

The **Data Packing** feature allows you to ensure that a string of data is not split up into more than one packet.

Delimiter 2 is optional. If left blank, then Delimiter 1 alone trips clearing of the buffer. If the size of the serial data received is greater than 1K, then NE-4000T-RC will automatically pack the data and send it to the Ethernet port. However, to use the delimiter function, you must at least enable Delimiter 1. If Delimiter 1 is left blank and Delimiter 2 is enabled, the delimiter function will not work properly.

The Force Tx Timeout parameter is used to force transmission if the time limit is reached. Set the parameter to 0 (zero) to deactivate this feature.

Note that the system obeys the *first* condition that it detects. That is, a packet is sent as soon as the Delimiter(s) are received, or as soon as the Force Tx Timeout is reached, whichever comes first.

TCP Server Mode

Check the **Modify** box, select the NE-4000T-TS you would like to configure, and then click on the **Settings** button in the lower right corner of the window.

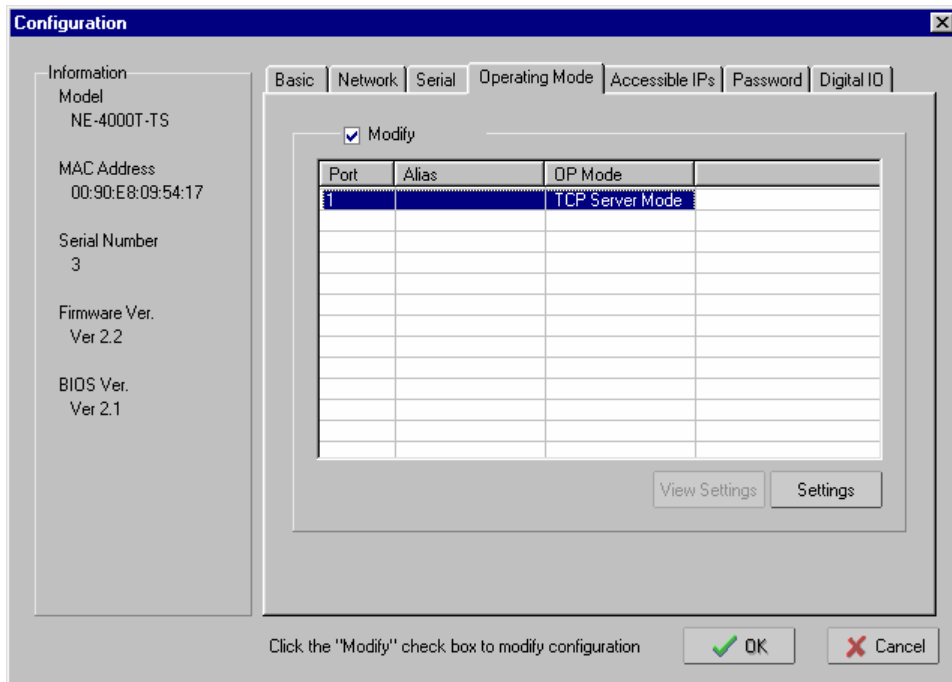

The TCP Server configuration panel will open.

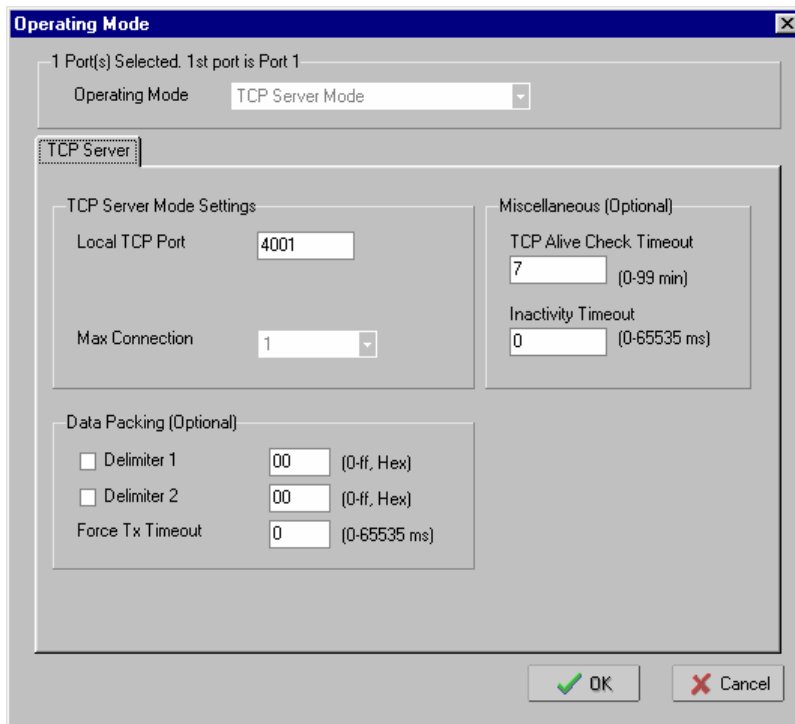

Local TCP Port

Setting	Factory Default	Necessity
xxxx (e.g., 4001)	4001	Required

The TCP port that NE-4000T-TS uses to listen to connections, and that other devices must use to contact the NE-4000T-TS. To avoid conflicts with well known TCP ports, the default is set to 4001.

TCP Alive Check Timeout

Setting	Factory Default	Necessity
0 to 99 min	7 min	Optional

0 min: TCP connection is not closed due to an idle TCP connection.

1 to 99 min: NE-4000T-TS automatically closes the TCP connection if there is no TCP activity for the given time. After the connection is closed, NE-4000T-TS starts listening for another host's TCP connection.

Inactivity Timeout

Setting	Factory Default	Necessity
0 to 65535 ms	0 ms	Optional

0 ms: TCP connection is not closed due to an idle serial line.

0-65535 ms: NE-4000T-TS automatically closes the TCP connection if there is no serial data activity for the given time. After the connection is closed, NE-4000T-TS starts listening for another host's TCP connection.

This parameter defines the maintenance status as Closed or Listen on the TCP connection. The connection is closed if there is no incoming or outgoing data through the serial port during the specific Inactivity time.

If the value of the inactivity time is set to 0, the current TCP connection is maintained until there is a connection close request. Although inactivity time is disabled, the NE-4000T-TS will check the connection status between the NE-4000T-TS and remote host by sending "keep alive" packets periodically. If the remote host does not respond to the packet, it assumes that the connection was closed down unintentionally. NE-4000T-TS will then force the existing TCP connection to close.

Delimiter 1

Setting	Factory Default	Necessity
00 to FF	None	Optional

Delimiter 2

Setting	Factory Default	Necessity
00 to FF	None	Optional

Force Tx Timeout

Setting	Factory Default	Necessity
0 to 65535 ms	0	Optional

The **Data Packing** feature allows you to ensure that a string of data is not split up into more than one packet.

Delimiter 2 is optional. If left blank, then Delimiter 1 alone trips clearing of the buffer. If the size of the serial data received is greater than 1K, then NE-4000T-TS will automatically pack the data and send it to the Ethernet port. However, to use the delimiter function, you must at least enable Delimiter 1. If Delimiter 1 is left blank and Delimiter 2 is enabled, the delimiter function will not work properly.

The Force Tx Timeout parameter is used to force transmission if the time limit is reached. Set the parameter to 0 (zero) to deactivate this feature.

Note that the system obeys the *first* condition that it detects. That is, a packet is sent as soon as the Delimiter(s) are received, or as soon as the Force Tx Timeout is reached, whichever comes first.

TCP Client Mode

Check the **Modify** box, select the NE-4000T-TC you would like to configure, and then click on the **Settings** button in the lower right corner of the window.

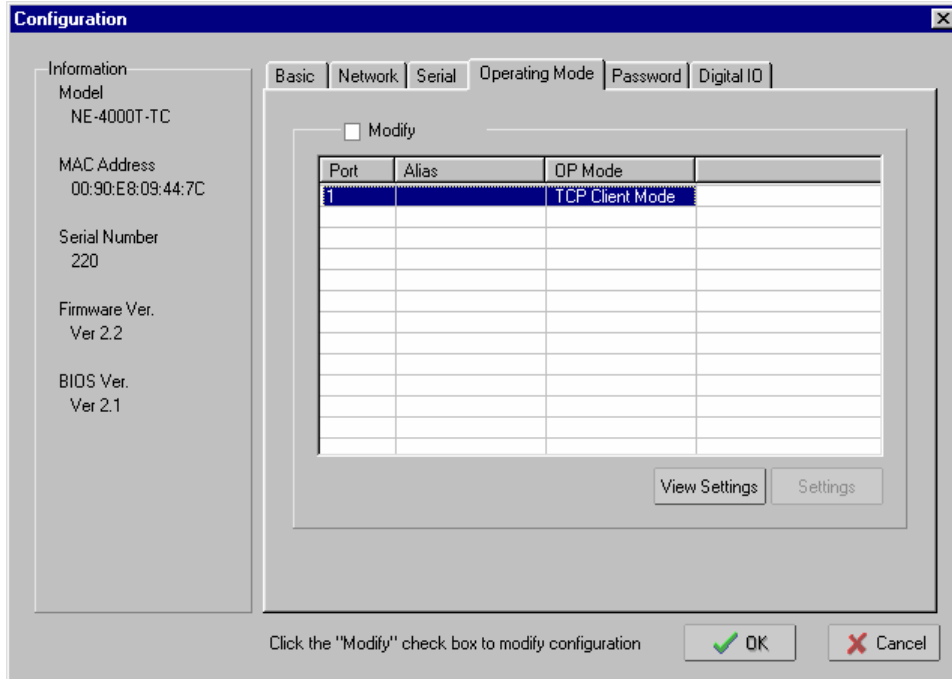

The TCP Client configuration panel will open.

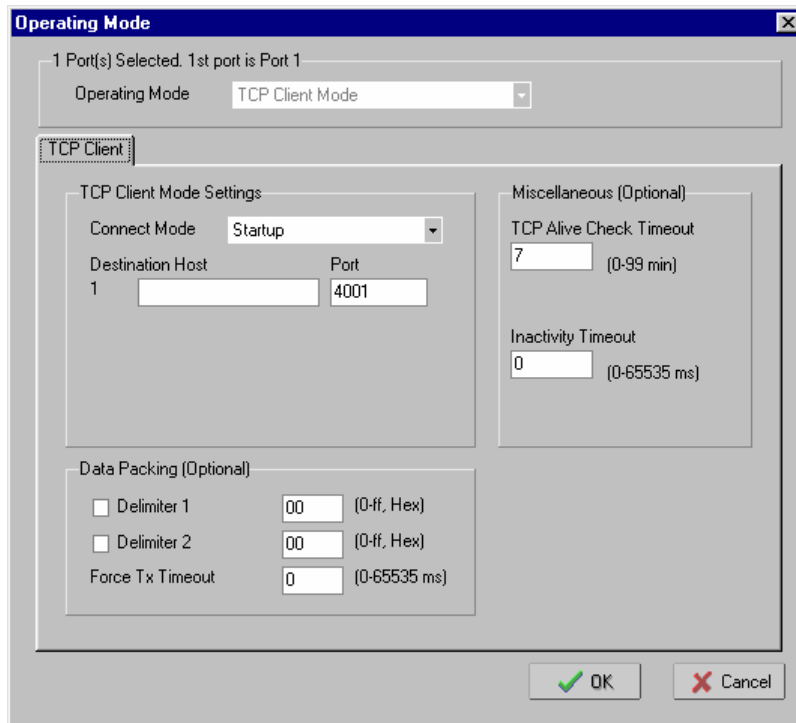

Connect Mode

Setting	Factory Default	Necessity
Startup or Any Character	Startup	N/A

If **Startup** is selected, the NE-4000T-TC will attempt to establish a connection with the Destination Host as soon as it receives power and boots up. If **Any Character** is selected, the NE-4000-TC will attempt to establish a connection with the Destination Host when it receives any character from the serial device.

Destination Host 1

Setting	Factory Default	Necessity
xxx.xxx.xxx.xxx (e.g., 192.168.127.16)	blank	Required

Port

Setting	Factory Default	Necessity
1 to 65535	4001	Required

The “IP address : Port” that NE-4000-TC will establish a connection with. To avoid conflicts with well known TCP ports, the default is set to 4001.

TCP Alive Check Timeout

Setting	Factory Default	Necessity
0 to 99 min	7 min	Optional

0 min: TCP connection is not closed due to an idle TCP connection.

1 to 99 min: NE-4000T-TC automatically closes the TCP connection if there is no TCP activity for the given time.

Inactivity Timeout

Setting	Factory Default	Necessity
0 to 65535 ms	0 ms	Optional

0 ms: TCP connection is not closed due to an idle serial line.

0-65535 ms: NE-4000T-TC automatically closes the TCP connection if there is no serial data activity for the given time.

This parameter defines the maintenance status as Closed or Listen on the TCP connection. The connection is closed if there is no incoming or outgoing data through the serial port during the specific Inactivity time.

If the value of the inactivity time is set to 0, the current TCP connection is maintained until there is a connection close request. Although inactivity time is disabled, the NE-4000T-TC will check the connection status between the NE-4000T-TC and remote host by sending "keep alive" packets periodically. If the remote host does not respond to the packet, it assumes that the connection was closed down unintentionally. NE-4000T-TC will then force the existing TCP connection to close.

Delimiter 1

Setting	Factory Default	Necessity
00 to FF	None	Optional

Delimiter 2

Setting	Factory Default	Necessity
00 to FF	None	Optional

Force Tx Timeout

Setting	Factory Default	Necessity
0 to 65535 ms	0	Optional

The **Data Packing** feature allows you to ensure that a string of data is not split up into more than one packet.

Delimiter 2 is optional. If left blank, then Delimiter 1 alone trips clearing of the buffer. If the size of the serial data received is greater than 1K, then NE-4000T-TC will automatically pack the data and send it to the Ethernet port. However, to use the delimiter function, you must at least enable Delimiter 1. If Delimiter 1 is left blank and Delimiter 2 is enabled, the delimiter function will not work properly.

The Force Tx Timeout parameter is used to force transmission if the time limit is reached. Set the parameter to 0 (zero) to deactivate this feature.

Note that the system obeys the *first* condition that it detects. That is, a packet is sent as soon as the Delimiter(s) are received, or as soon as the Force Tx Timeout is reached, whichever comes first.

UDP Mode

Check the **Modify** box, select the NE-4000T-UD you would like to configure, and then click on the **Settings** button in the lower right corner of the window.

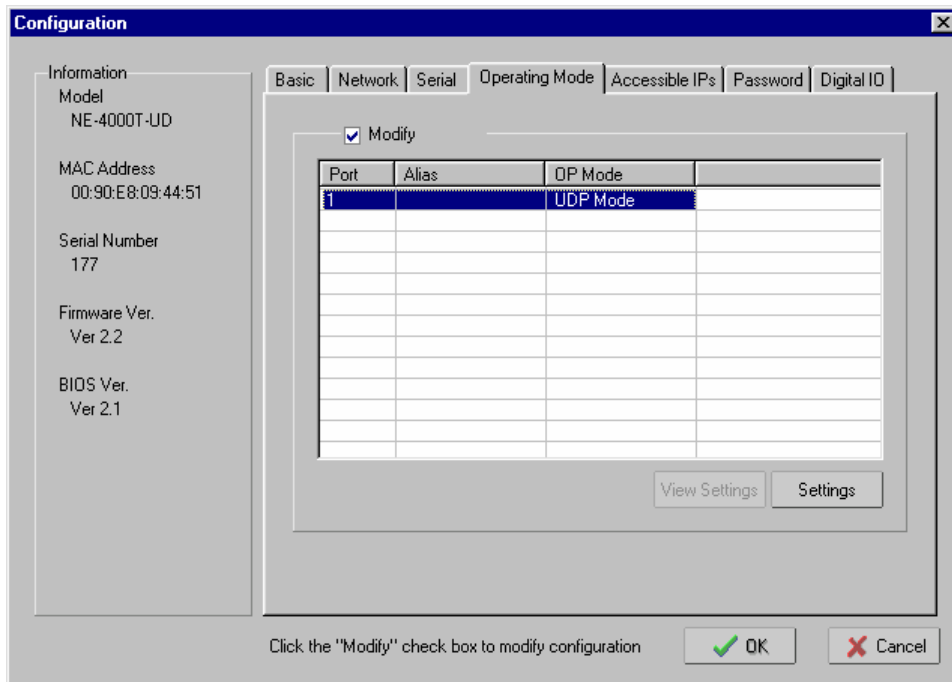

The UDP configuration panel will open.

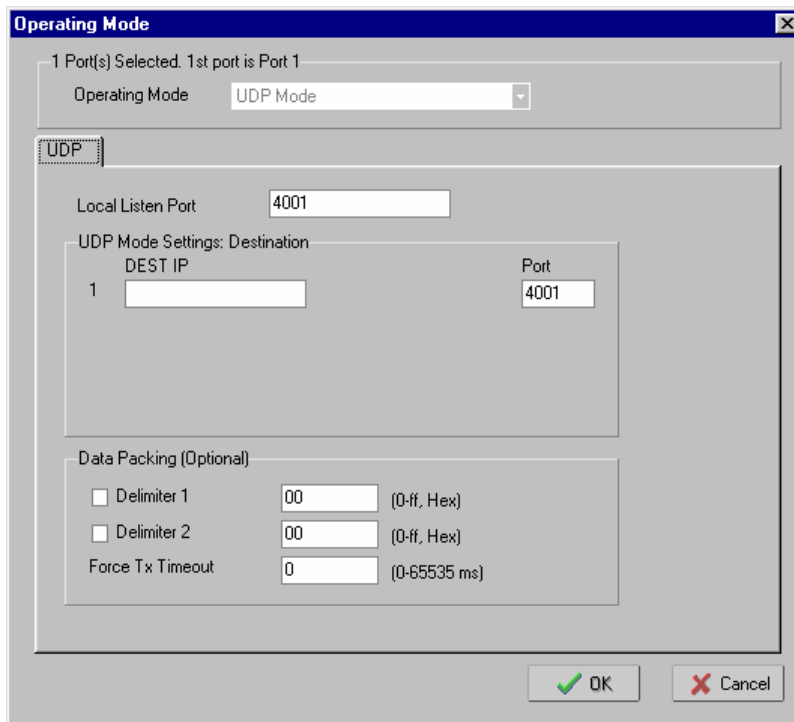

Local Listen Port

Setting	Factory Default	Necessity
xxx.xxx.xxx.xxx (e.g., 192.168.127.16)	blank	Required*

* Required for TCP Server applications. The "IP address : Port" that NE-4000-UD will establish a connection with. To avoid conflicts with well known TCP ports, the default is set to 4001.

DEST IP

Setting	Factory Default	Necessity
xxx.xxx.xxx.xxx (e.g., 192.168.127.16)	blank	Required*

Port

Setting	Factory Default	Necessity
1 to 65535	4001	Required*

* Required for TCP Client applications. The "IP address : Port" that NE-4000-UD will establish a connection with. To avoid conflicts with well known TCP ports, the default is set to 4001.

Port

Setting	Factory Default	Necessity
0 to 65535 ms	0 ms	Optional

0 ms: TCP connection is not closed due to an idle serial line.

0-65535 ms: NE-4000T-UD automatically closes the TCP connection if there is no serial data activity for the given time. After the connection is closed, NE-4000T-UD starts listening for another host's TCP connection.

This parameter defines the maintenance status as Closed or Listen on the TCP connection. The connection is closed if there is no incoming or outgoing data through the serial port during the specific Inactivity time.

If the value of the inactivity time is set to 0, the current TCP connection is maintained until there is a connection close request. Although inactivity time is disabled, the NE-4000T-UD will check the connection status between the NE-4000T-UD and remote host by sending "keep alive" packets periodically. If the remote host does not respond to the packet, it assumes that the connection was closed down unintentionally. NE-4000T-UD will then force the existing TCP connection to close.

Delimiter 1

Setting	Factory Default	Necessity
00 to FF	None	Optional

Delimiter 2

Setting	Factory Default	Necessity
00 to FF	None	Optional

Force Tx Timeout

Setting	Factory Default	Necessity
0 to 65535 ms	0	Optional

The **Data Packing** feature allows you to ensure that a string of data is not split up into more than one packet.

Delimiter 2 is optional. If left blank, then Delimiter 1 alone trips clearing of the buffer. If the size of the serial data received is greater than 1K, then NE-4000T-UD will automatically pack the data and send it to the Ethernet port. However, to use the delimiter function, you must at least enable Delimiter 1. If Delimiter 1 is left blank and Delimiter 2 is enabled, the delimiter function will not work properly.

The Force Tx Timeout parameter is used to force transmission if the time limit is reached. Set the parameter to 0 (zero) to deactivate this feature.

Note that the system obeys the *first* condition that it detects. That is, a packet is sent as soon as the Delimiter(s) are received, or as soon as the Force Tx Timeout is reached, whichever comes first.

Accessible IPs

The **Accessible IPs** tab applies to NE-4000T-RC (Real COM mode), NE-4000T-TS (TCP Server mode), and NE-4000T-UD (UDP mode). NE-4000T-TC does not have an Accessible IPs tab, since TCP Client network hosts must initiate communication. In fact, NE-4000T-TC will only communicate with hosts which have *IP Address : Port = Destination Host 1 : Port*.

If the **Enable** box is checked, the NE-4000T will only accept connection requests from network hosts with IP Address equal to one of the four active IP Addresses that appear in the Accessible IPs table. The host must also belong to the subnet defined by the corresponding **Netmask**. If the **Enable** box is not checked, the NE-4000T will accept connection requests from any network host.

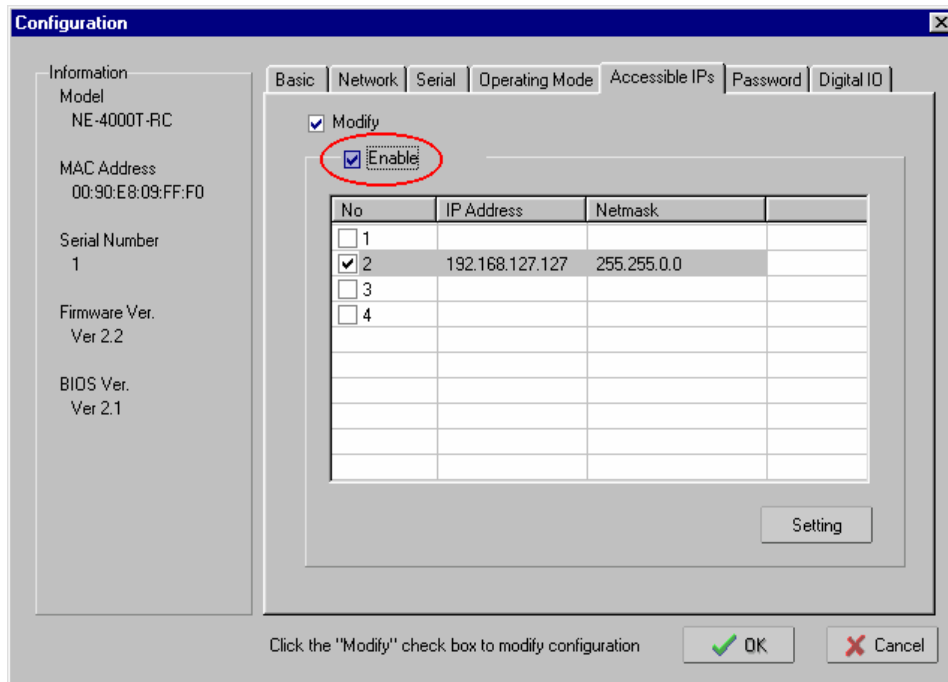

To add or modify Accessible IPs settings, check the **Modify** box, highlight the row whose IP Address / Netmask combination you wish to edit by clicking on the row, and then click on the **Setting** button located just below the table. Enter or modify **IP Address** and **Netmask**, and then click on **OK**.

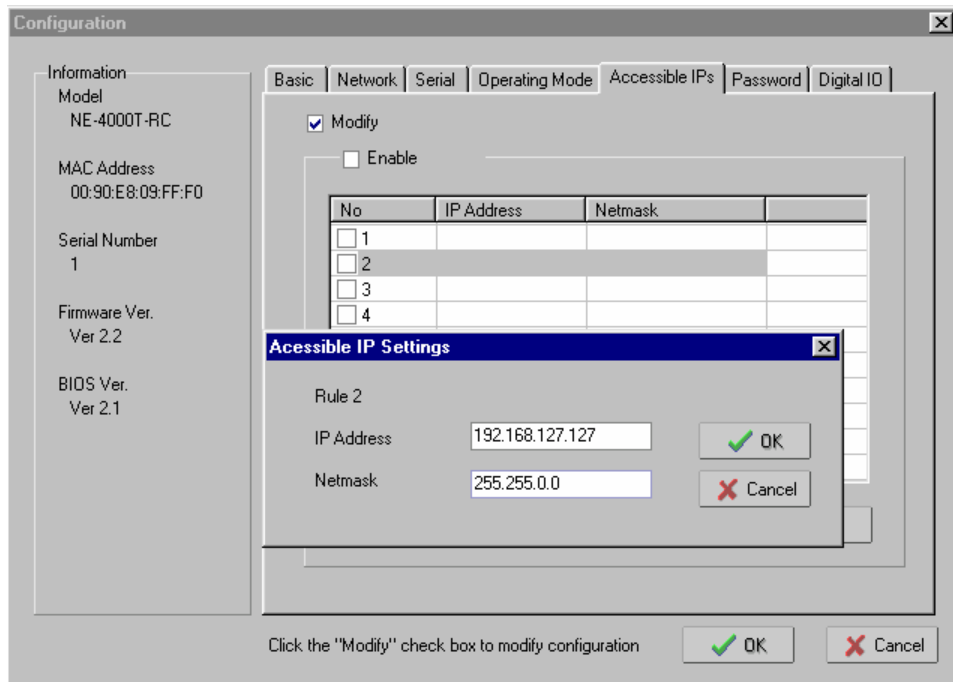

Check the box for that row to activate the IP Address / Netmask combination as an Accessible IP / Subnet combination.

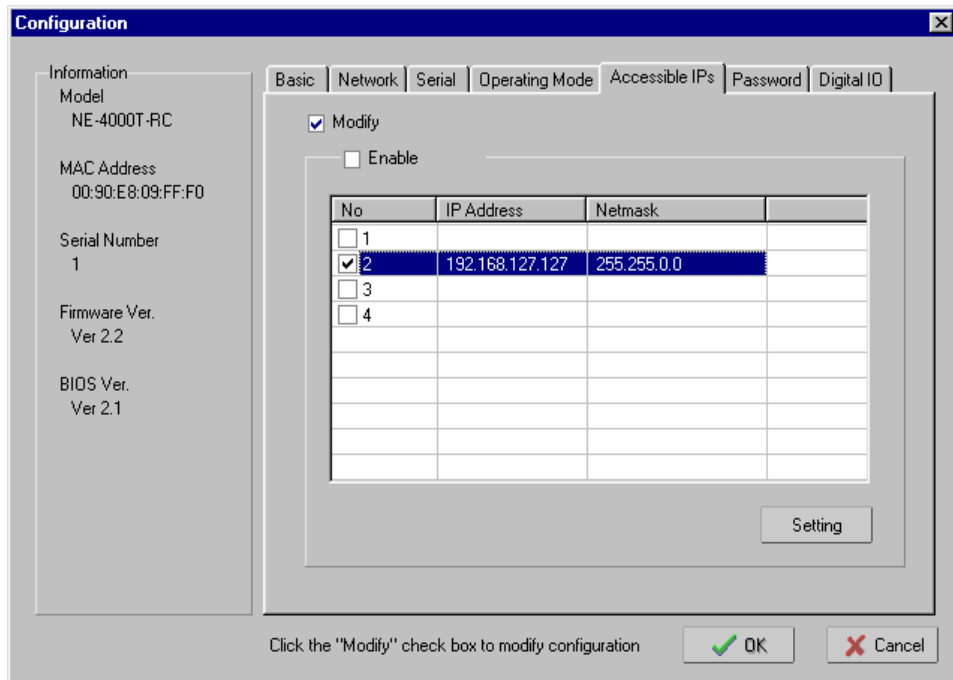

Accessible IP Settings allows you to add or remove “Legal” remote host IP addresses to prevent unauthorized access. Access to NE-4000Ts is controlled by IP address. That is, if a host’s IP address is in the accessible IP table, then the host will be allowed to access the NE-4000T.

You can allow one of the following cases by setting the parameters accordingly.

- **Only one host with a specific IP Address can access the NE-4000T**
Enter the specific IP address (e.g., 192.168.1.1) and enter 255.255.255.255 for Netmask.
- **Hosts on the specific subnet can access the NE-4000T**
Enter an IP address (e.g., 192.168.1.0) and enter 255.255.255.0 for Netmask. Note that type of setting will allow access to all network hosts on a particular subnet.
- **Any host can access the NE-4000T**
Disable this function by not entering any IP address or Netmask settings, or by removing the checkmark from the **Enable** box.

The following "Allowable Hosts" table gives five configuration examples.

Allowable Hosts	IP Address	Netmask
Any host	<i>blank</i>	<i>blank</i>
192.168.1.120	192.168.1.120	255.255.255.255
192.168.1.1 to 192.168.1.254	192.168.1.0	255.255.255.0
192.168.0.1 to 192.168.255.254	192.168.0.0	255.255.0.0
192.168.1.1 to 192.168.1.126	192.168.1.0	255.255.255.128

Password

To change the password, check the **Modify** box and then enter the new password. Leave the password boxes blank to erase the password. In this case, the NE-4000T will not have password protection.

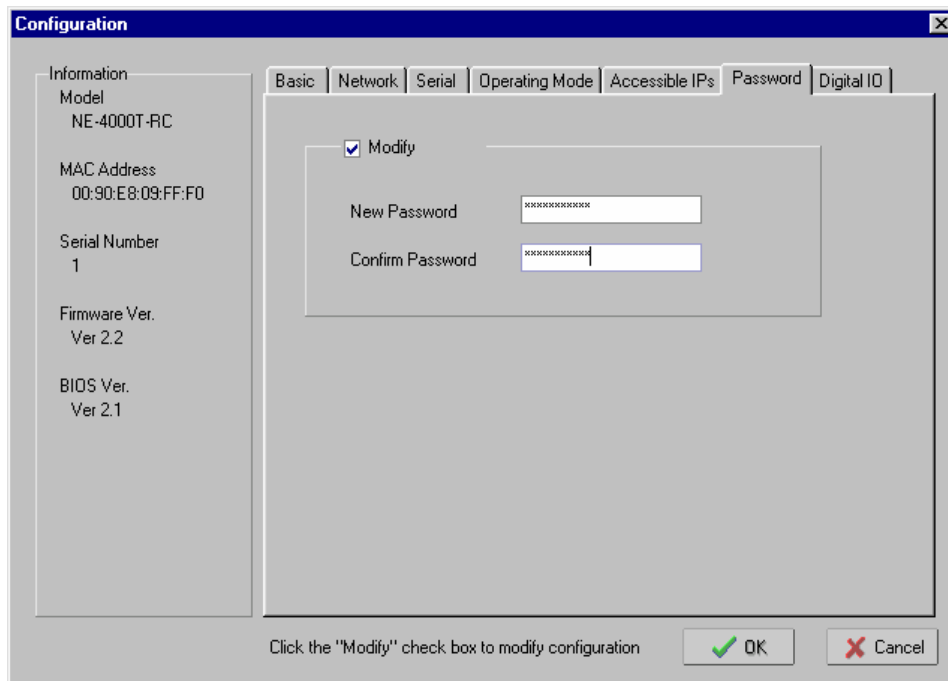

Digital I/O

NE-4000T's DI/O Settings were explained in detail in Chapter 3.

To change a DI/O setting, check the **Modify** box, click on the DI/O you wish to modify to highlight it, and then click on the **Setting** button.

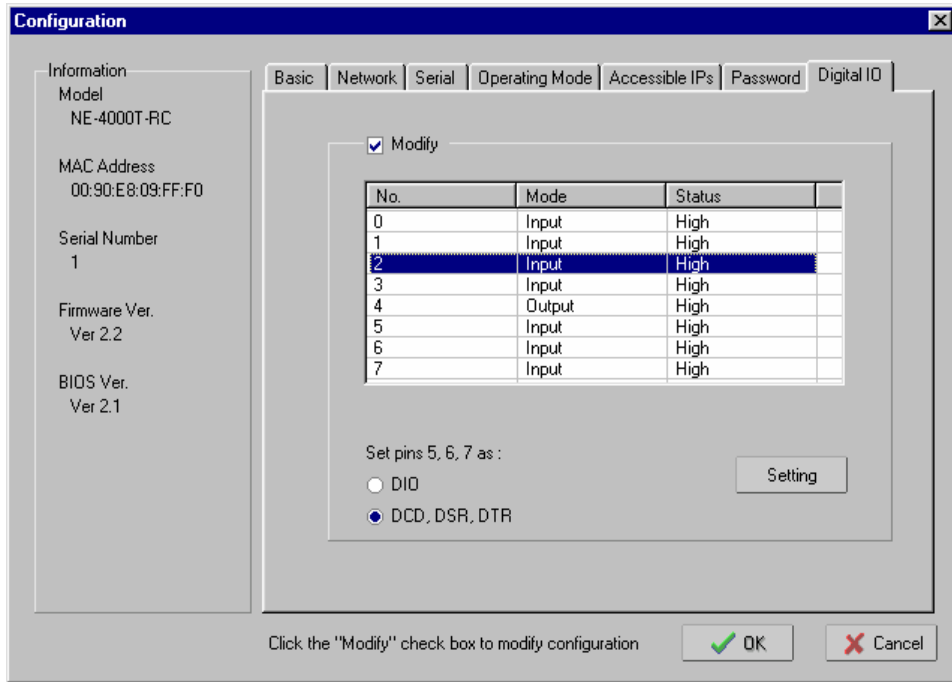

DI/O Set as Input

The **Status** of a DI/O set to **Input** mode is irrelevant, so when Mode is set to Input, the Status option is not active.

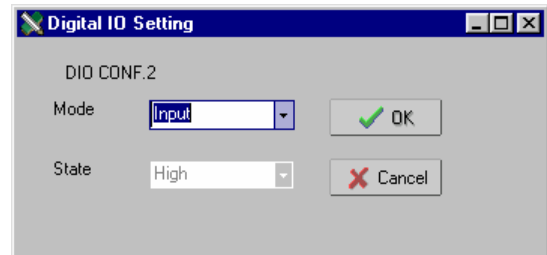

DI/O Set as Output

The **Status** of a DI/O set to **Output** mode can be set to **High** or **Low**.

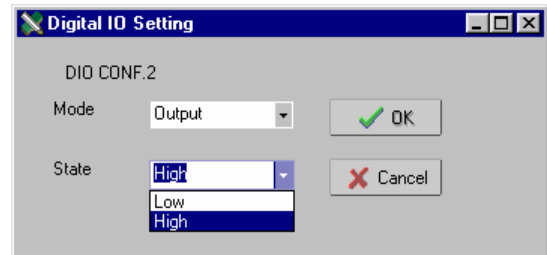

DI/O Pins 5, 6, 7

DI/O pins 5, 6, and 7 serve a dual purpose. By default, these three pins are set to transmit the DCD, DSR, DTR modem control signals. To set pins 5, 6, and 7 as DI/O pins, click the selection button to the left of “DIO” near the bottom of the window.

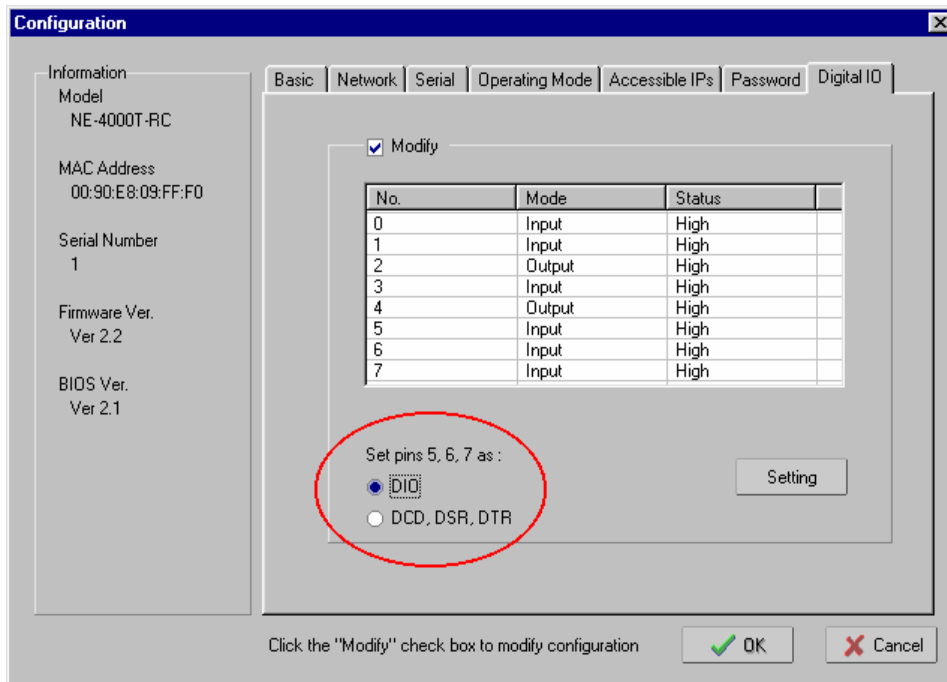

Applying modifications

1. After making changes to the configuration, click on **OK**.
2. Administrator will take a few seconds to process the modifications.

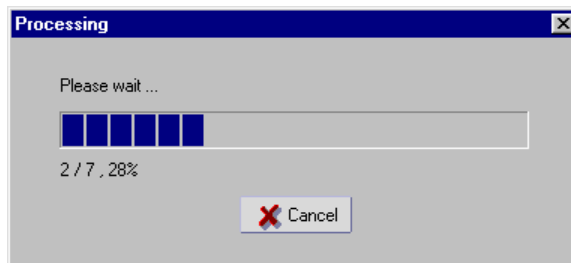

3. Click on **OK** to complete the configuration.

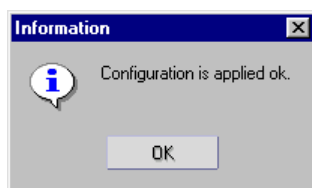

Export/Import Functions

- To export a configuration, select the NE-4000T whose configuration you would like to export, click the right mouse button, and then select **Export Configuration** from the drop down menu.

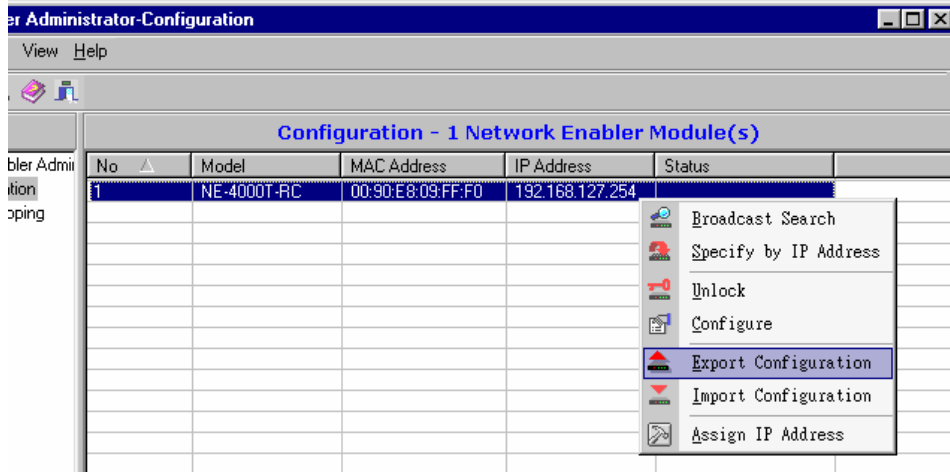

- A **Select File** window will open next. Enter the target directory for the configuration file, or click on **Browse** to search. Click on **OK** to return to the **Administrator** window.

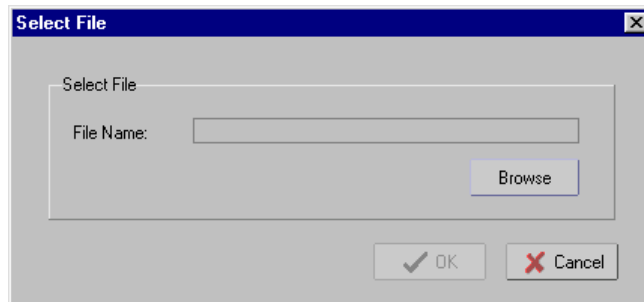

- To import a configuration, select the target NE-4000T, click the right mouse button, and then select **Import Configuration** from the drop down menu.

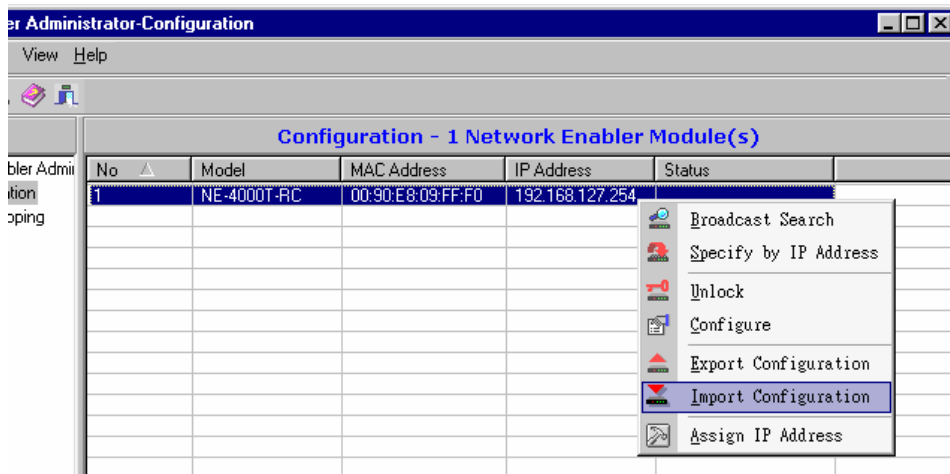

4. A **Select File** window will open next. Enter the source directory of the configuration file, or click on **Browse** to search. Click on **OK** to return to the **Administrator** window.

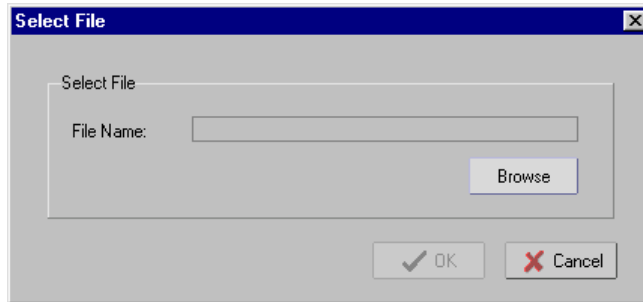

5

Web Console Configuration

The Web Console provides a convenient way to configure some of the most basic NE-4000T settings.

This chapter covers the following topics:

- ❑ **Opening Your Browser**
- ❑ **Network Settings**
- ❑ **Accessible IP Settings**
- ❑ **Change Password**
- ❑ **Restart/Logout**

Opening Your Browser

Before opening your browser, you need to enable cookies.

1. To enable your browser for cookies, right click on your desktop Internet Explorer icon, select **Properties**, and then click on the **Security** tab.

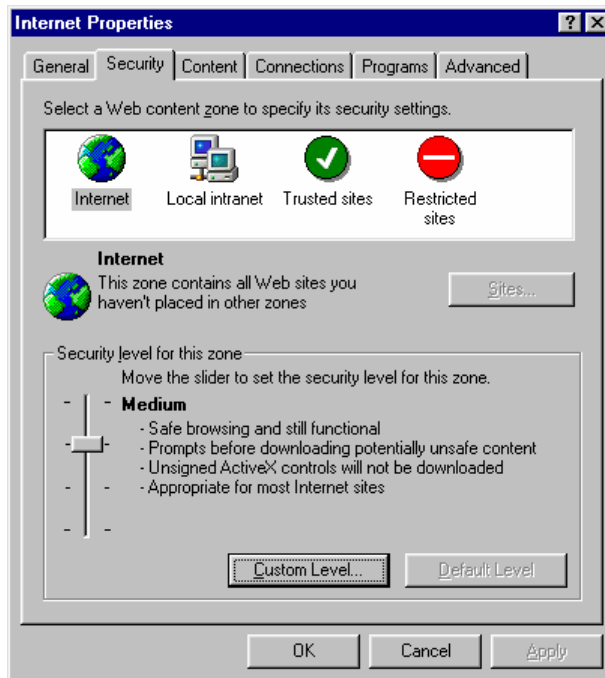

2. Enable the three options shown in the figure below, and then click on **OK**.

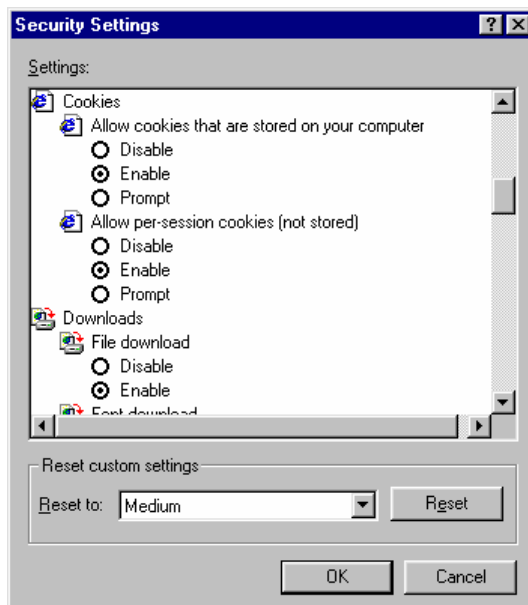

3. Enter the NE-4000T's IP address in your web browser's address box, and then press the **Enter** key on your keyboard. A screen will open, displaying detailed information about NE-4000T.

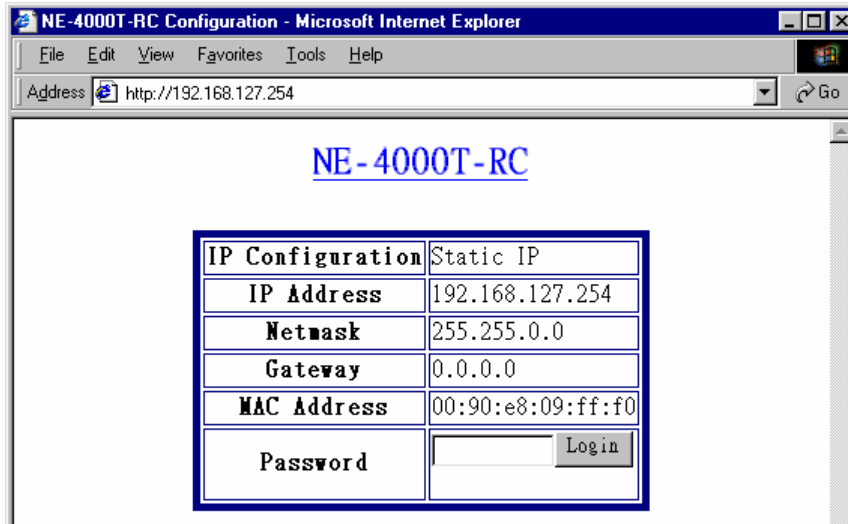

4. Input the password, if the NE-4000T is password protected, and then click on **Login**. The password is transmitted without MD5 encryption over the Ethernet. (Leave the password box empty if the device is NOT password protected.)

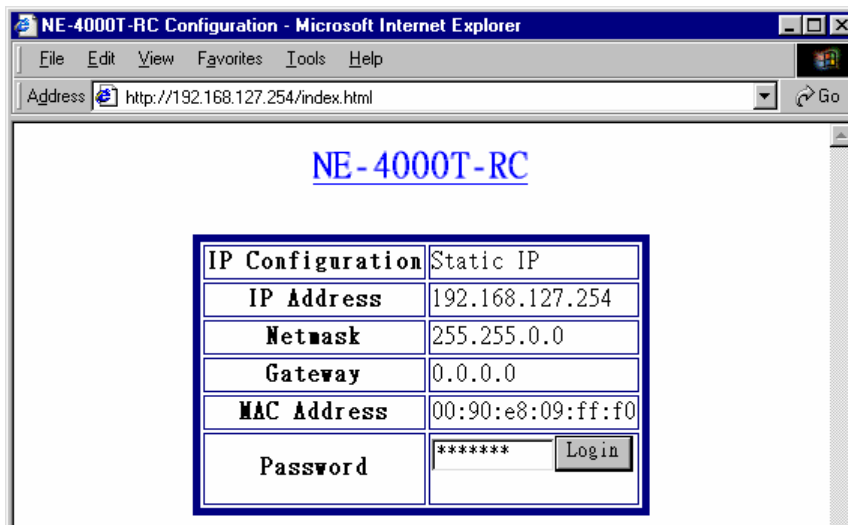

5. The NE-4000T **Networking Settings** screen will open.

The screenshot shows the 'Network Settings' page in a web browser. The browser title is 'NE-4000T-RC Web Console - Microsoft Internet Explorer' and the address bar shows 'http://192.168.127.254/cgi/login'. The page has a light blue background. On the left, there is a yellow sidebar with the following links: [Network Settings](#), [Accessible IP Settings](#), [Change Password](#), [Restart](#), and [Logout](#). The main content area is titled 'Network Settings' and contains a table of configuration fields:

Device Name	NE-4000T-RC
IP Configuration	Static IP
IP Address	192.168.127.254
Netmask	255.255.0.0
Gateway	
MAC Address	00:90:e8:09:ff:f0
Model	NE-4000T-RC

Below the table is a 'Save' button. At the bottom of the page, there is a note: '*Please press 'Restart' on the left to activate the settings. *In DHCP Mode, the IP address may dynamically change. Please use the windows utility to search and locate the device.'



ATTENTION

If you use other web browsers, remember to enable the functions to “allow cookies that are stored on your computer” or “allow per-session cookies.”

NE-4000T only uses cookies for the “password” transmission.

Network Settings

If necessary, click on the **Network Settings** link on the left side of the screen to open the **Networking Settings** screen. Make necessary changes to the settings and then click on **Apply** to validate the modifications.

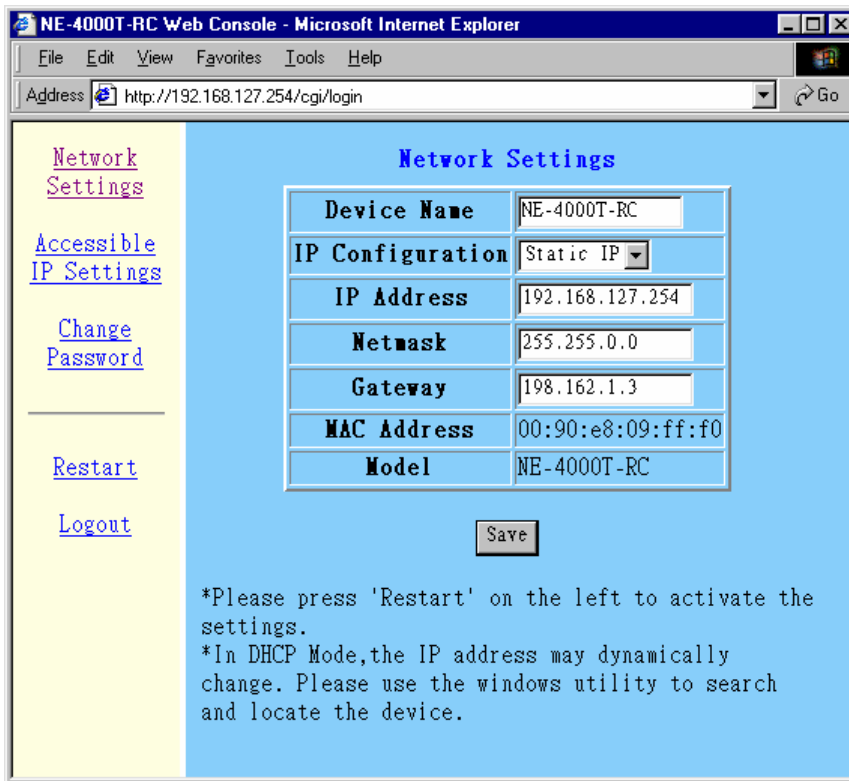

ATTENTION

If your NE-4000T application requires using password protection, you must enable the cookie function in your browser. If the cookie function is disabled, you will not be allowed to enter the Web Console Screen.

Device Name

Setting	Factory Default	Necessity
1 to 15 characters	NE-4000T-MN (MN = RC, TS, TC, or UD)	Optional

This option is useful for specifying the location or application of different NE-4000T units.

IP Configuration

Setting	Factory Default	Necessity
Static or DHCP	Static	Required

When the DHCP option is selected, NE-4000T will search for a DHCP server by transmitting DHCP broadcast packets over the network. If a DHCP server is located, NE-4000T will automatically update IP Address, Netmask, and Gateway to the values provided by the DHCP server. If a DHCP server is not located within 1 minute, NE-4000T will configure the network settings to the default values. If the IP address changes, you will need to conduct a new Broadcast Search to locate the NE-4000T.

IP Address

Setting	Factory Default	Necessity
x.x.x.x (E.g., 192.168.1.1. IP addresses of the form x.x.x.0 and x.x.x.255 are invalid.)	192.168.127.254	Required

An IP address is a number assigned to a network device (such as a computer) as a permanent address on the network. Computers use the IP address to identify and talk to each other over the network. Choose a proper IP address that is unique and valid in your network environment.

Netmask

Setting	Factory Default	Necessity
Ex. 255.255.255.0	255.255.0.0	Required

The netmask is used to group network hosts into a particular subnet. When a packet is sent out over the network, the NE-4000T will use the netmask to check whether the desired TCP/IP host specified in the packet is on the subnetwork. If the address is on the same subnet as the NE-4000T, a connection is established directly from the NE-4000T. Otherwise, the packet is sent to the Gateway address.

Gateway

Setting	Factory Default	Necessity
Ex. 192.168.1.1	None	Optional

A gateway is usually a router that links the subnet to a larger network. Typically, the computers that control traffic within the network or at the local Internet service provider are gateway nodes. NE-4000T needs to know the IP address of the default gateway computer in order to communicate with the hosts outside the local network environment. Contact your network administrator to get the correct gateway IP address for your NE-4000T.

Accessible IP Settings

Click on **Accessible IP Settings** link on the left side of the screen to open the **Accessible IP Settings** window. Make necessary changes to the settings and click on **Apply** to validate the modifications.

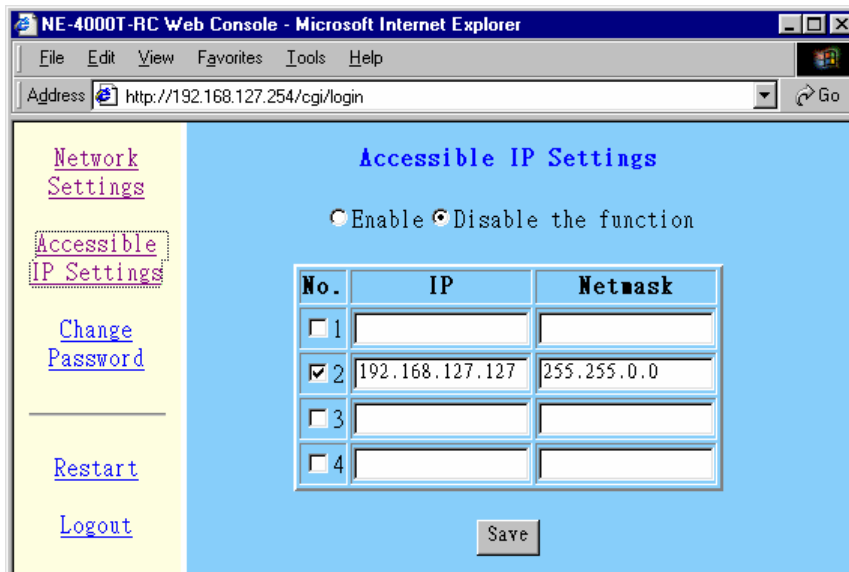

NE-4000T has an IP address-based filtering method to control access to the NE-4000T. Accessible IP Settings allows you to add or remove “Legal” remote host IP addresses to prevent unauthorized access. Access to NE-4000Ts is controlled by IP address. That is, if a host’s IP address is in the accessible IP table, then the host will be allowed to access the NE-4000T. You can allow one of the following cases by setting the parameters accordingly.

- **Only one host with a specific IP Address can access the NE-4000T**
Enter the specific IP address (e.g., 192.168.1.1) and enter 255.255.255.255 for Netmask.
- **Hosts on the specific subnet can access the NE-4000T**
Enter IP address (e.g., 192.168.1.0) and enter 255.255.255.0 for Netmask.
- **Any host can access the NE-4000T**
Disable this function by not entering any IP address or Netmask settings.

Refer to the following table for more details about the configuration example.

Allowable Hosts	IP Address	Netmask
Any host	<i>blank</i>	<i>blank</i>
192.168.1.120	192.168.1.120	255.255.255.255
192.168.1.1 to 192.168.1.254	192.168.1.0	255.255.255.0
192.168.0.1 to 192.168.255.254	192.168.0.0	255.255.0.0
192.168.1.1 to 192.168.1.126	192.168.1.0	255.255.255.128

Change Password

To change the password, enter the old password in the box next to **Old**, and enter a new one in the box next to **New**. Then reenter the new password in the box next to **Confirm**. Leave the password boxes blank to erase the password. In this case, the NE-4000T will not have password protection. Click on **Apply** to validate the modifications.

The screenshot shows a web browser window titled "NE-4000T-RC Web Console - Microsoft Internet Explorer". The address bar contains "http://192.168.127.254/cgi/login". The main content area has a light blue background and is titled "Change Password". It features three input fields: "Old" with "*****", "New" with "*****", and "Confirm" with "*****". Below these fields is a "Save" button. On the left side, there is a yellow sidebar with several links: "Network Settings", "Accessible IP Settings", "Change Password", "Restart", and "Logout".

Restart/Logout

Click on the **Restart** button on the left side of the screen if you would like to re-start the configuration. After all changes have been made and applied, click on **Logout** to exit the system.

6

Serial Console Configuration

This chapter introduces the procedure for using the serial console port on NE-4000T-ST to configure NE-4000T. Network Settings is used to illustrate the configuration procedure.

We suggest using MOXA PComm Terminal Emulator, which is available free of charge as part of the MOXA PComm Lite program suite, to carry out the configuration procedure. (Please go to www.moxa.com to download the PComm Lite installation program.)

Before you start to configure the NE-4000T via serial console, disconnect the power to NE-4000T-ST.

1. Use a serial cable to connect NE-4000T's serial port (the DB9 Male connector is located on NE-4000T-ST) directly to your computer's serial port.
2. From the Windows desktop, click on **Start** → **Programs** → **PComm Lite** → **Terminal Emulator**.
3. When the **PComm Terminal Emulator** window opens, first click on the **Port Manager** menu item and select **Open**, or simply click on the **Open** icon.

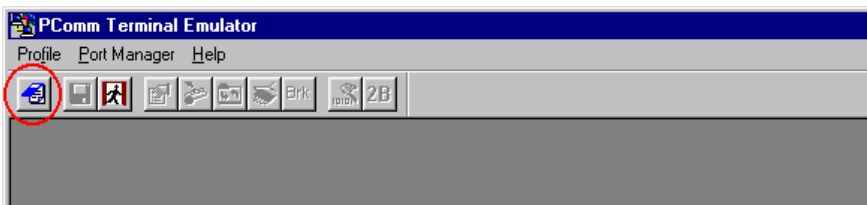

- The **Property** window opens automatically. From the **Communication Parameter** page, select the appropriate COM port for the connection, **COM1** in this example, and **19200** for **Baud Rate**, **8** for **Data Bits**, **None** for **Parity**, and **1** for **Stop Bits**.

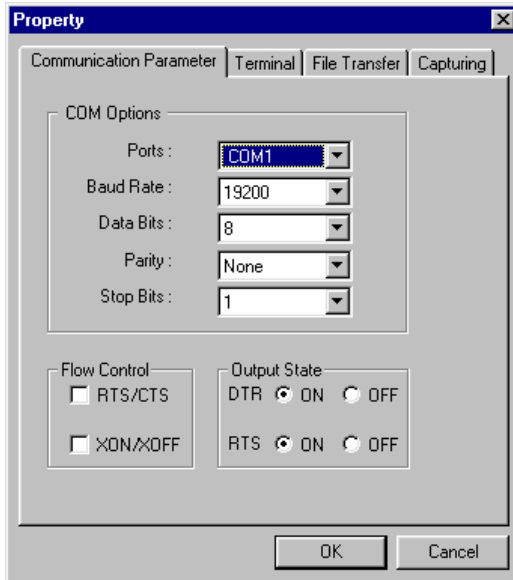

- From the **Property** window's **Terminal** page, select **ANSI** and then click on **OK**.

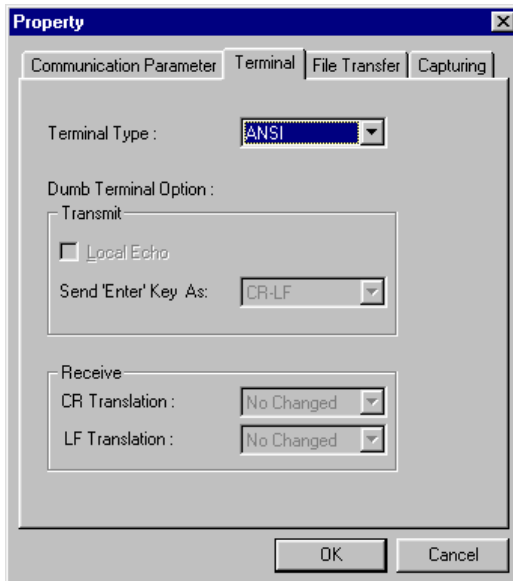

- Power on the NE-4000T and press "0" continuously until the serial console screen opens.

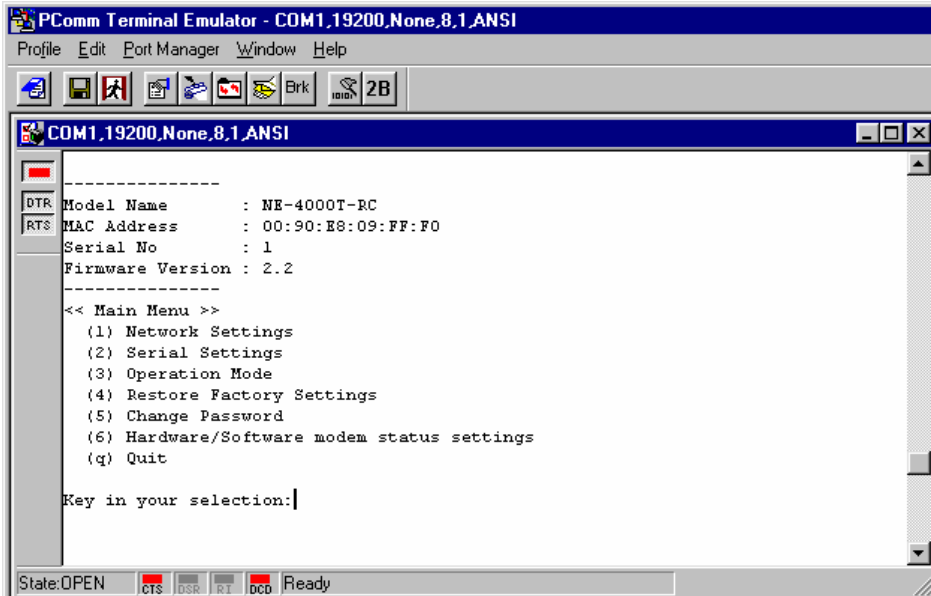

- Several options are displayed under **Main Menu**. To configure **Network Settings**, input **1** and then press the **Enter** key on your keyboard.

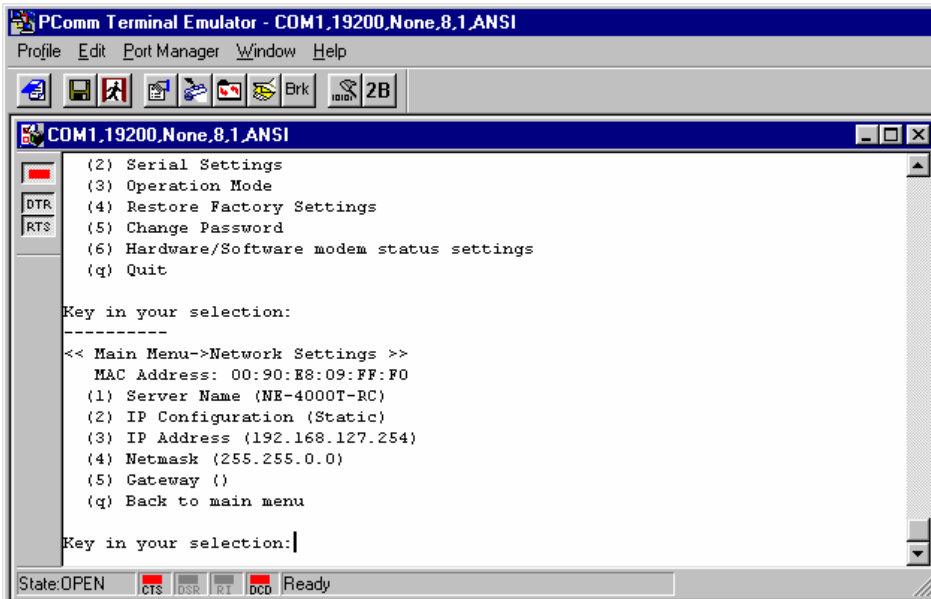

8. To change server name, input **1**. The **Server Name** will appear at the bottom of the screen. Type in the name for the NE-4000T. If you wish to continue making changes to other settings, just key in the number shown next to that item and configure the settings. Input **q** to return to the **Main Menu**.

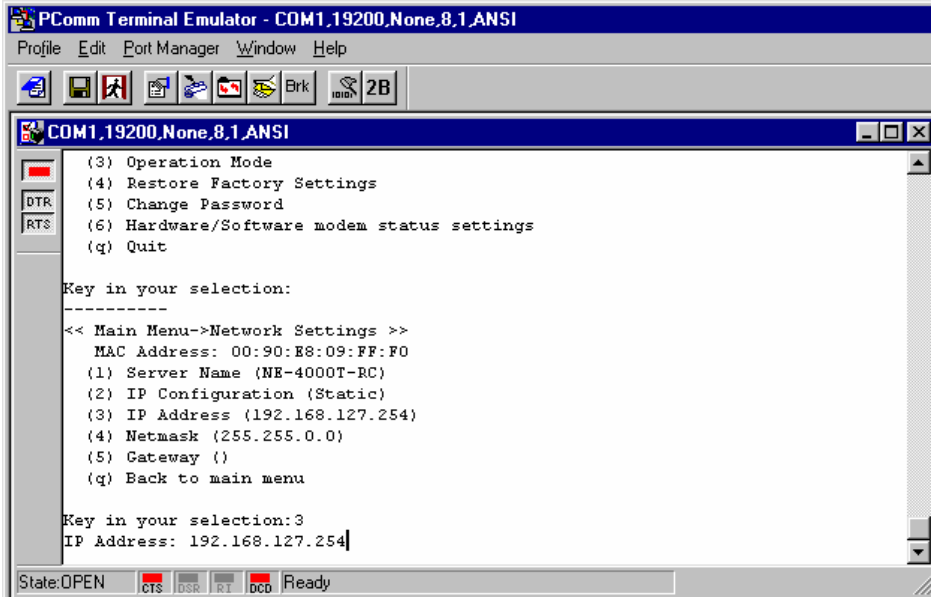

The screenshot shows a terminal window titled "PComm Terminal Emulator - COM1,19200,None,8,1,ANSI". The window contains a menu with the following options: (3) Operation Mode, (4) Restore Factory Settings, (5) Change Password, (6) Hardware/Software modem status settings, and (q) Quit. Below the menu, it prompts "Key in your selection:". The user has entered '3', and the screen displays "<< Main Menu->Network Settings >>", "MAC Address: 00:90:E8:09:FF:F0", and a sub-menu with options: (1) Server Name (NE-4000T-RC), (2) IP Configuration (Static), (3) IP Address (192.168.127.254), (4) Netmask (255.255.0.0), (5) Gateway {}, and (q) Back to main menu. The user has entered '3' again, and the screen displays "Key in your selection: 3" and "IP Address: 192.168.127.254". The status bar at the bottom shows "State:OPEN", "CTS", "DSR", "RT", "DCD", and "Ready".

9. Follow steps 7 and 8 to configure other settings, such as Serial Settings, DIO Settings, etc., until all necessary configuration is done.



ATTENTION

For more details about Network Settings, Serial Settings, Operation Mode, DIO Settings, Accessible IP Settings, and Restore Factory Settings, refer to Chapter 4.

Upgrading the Firmware

This chapter describes the procedure for upgrading the firmware. The latest version of the firmware can be downloaded free of charge from Moxa's website at www.moxa.com. You must use the serial console port on NE-4000T-ST to upgrade the firmware.

1. Click on **Start** → **Programs** → **PComm Lite** → **Terminal Emulator**.
2. When the **PComm Terminal Emulator** window opens, first click on the **Port Manager** menu item and select **Open**, or simply click on the **Open** icon.



3. The **Property** window opens automatically. From the **Communication Parameter** page, select the appropriate COM port for the connection, **COM1** in this example, and **19200** for **Baud Rate**, **8** for **Data Bits**, **None** for **Parity**, and **1** for **Stop Bits**.

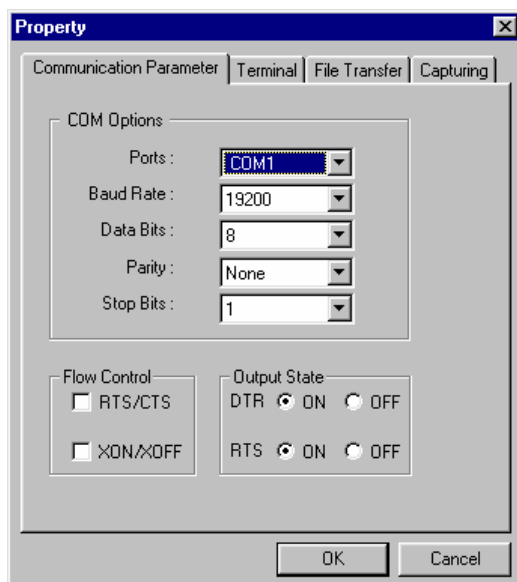

- From the **Property** window's **Terminal** page, select **ANSI** and then click on **OK**.

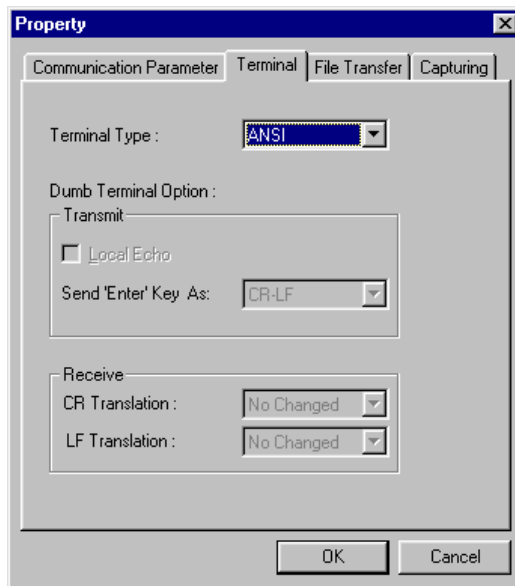

- Disconnect the power line from NE-400T-ST.
- Press the PRG button. While still pressing the PRG button, reconnect the power line to NE-400T-ST. Do not let go of the PRG button at this point.

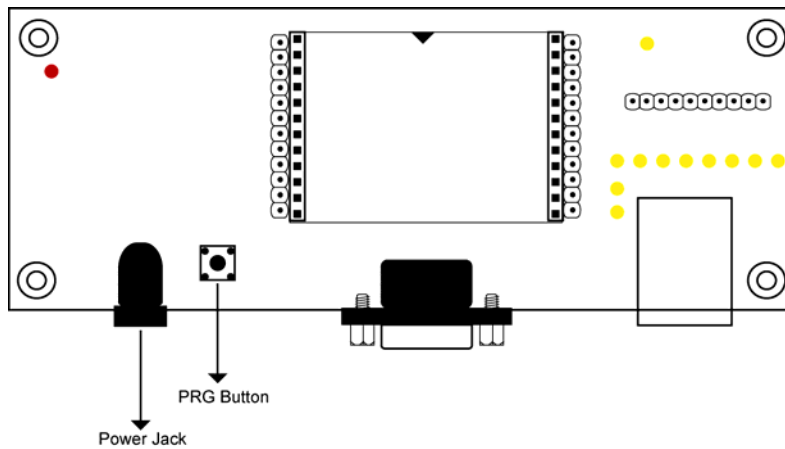

- Keep pressing the PRG button until the following screen appears. Type **U** (or click on the menu bar **File Transfer** icon) to start the Firmware Upgrade procedure.

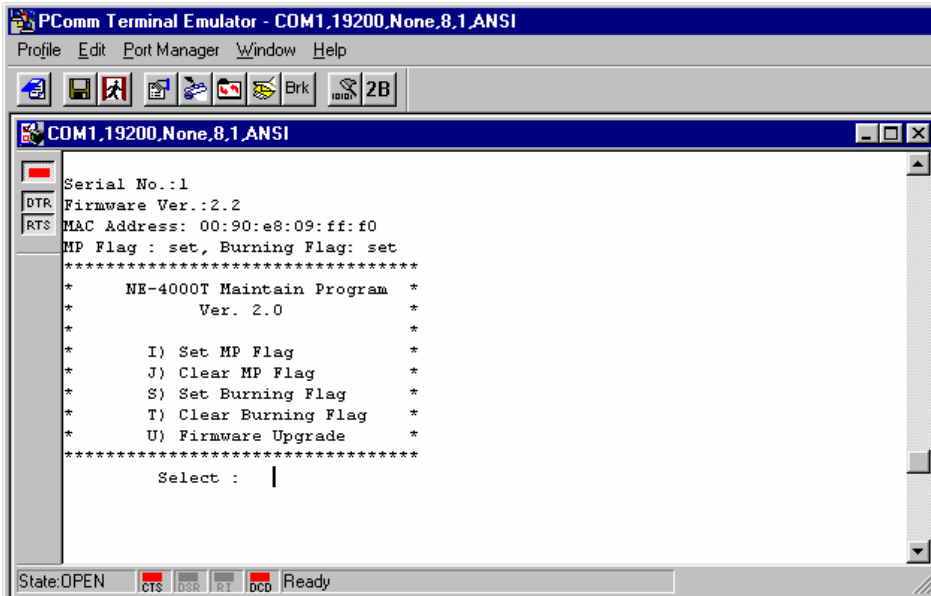

ATTENTION

Currently, the serial console is set up to allow end-users to upgrade NE-4000T's firmware. The additional functions shown in the above screen are not for general use.

DO NOT USE THE FOLLOWING FUNCTIONS

- I) Set MP Flag ← DO NOT USE
- J) Clear MP Flag ← DO NOT USE
- S) Set Burning Flag ← DO NOT USE
- T) Clear Burning Flag ← DO NOT USE

Using these functions could render your device unusable. Please contact the Moxa Service Center nearest you if you have questions about this restriction.

8. When the **File Transfer** window opens, select **Xmodem-Checksum** and then click on **OK**.

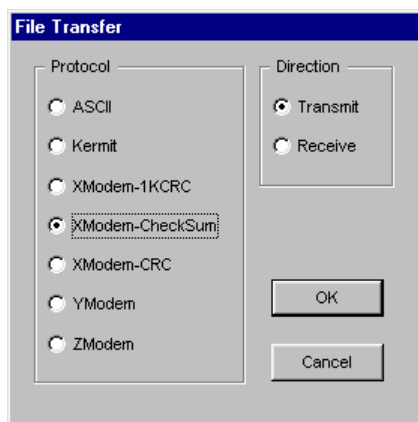

9. The **Transmit File** window opens next. Locate the *.ROM file that you downloaded from Moxa's website, and then click on **Open**.

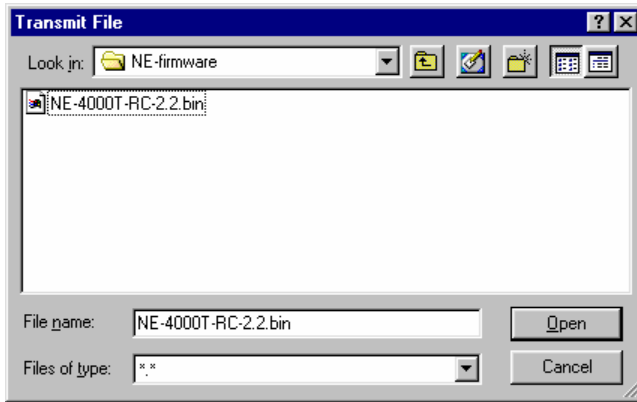

10. The next window to open shows that the program is upgrading the firmware.

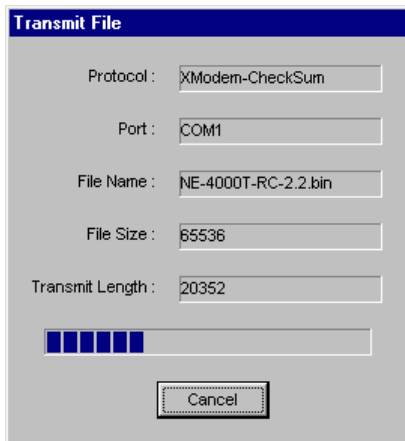

11. After the upgrading is finished, a window will open stating that the file has finished transmitting. Click on **OK** to continue.

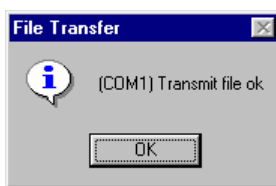

12. Press any key to return to the main menu.

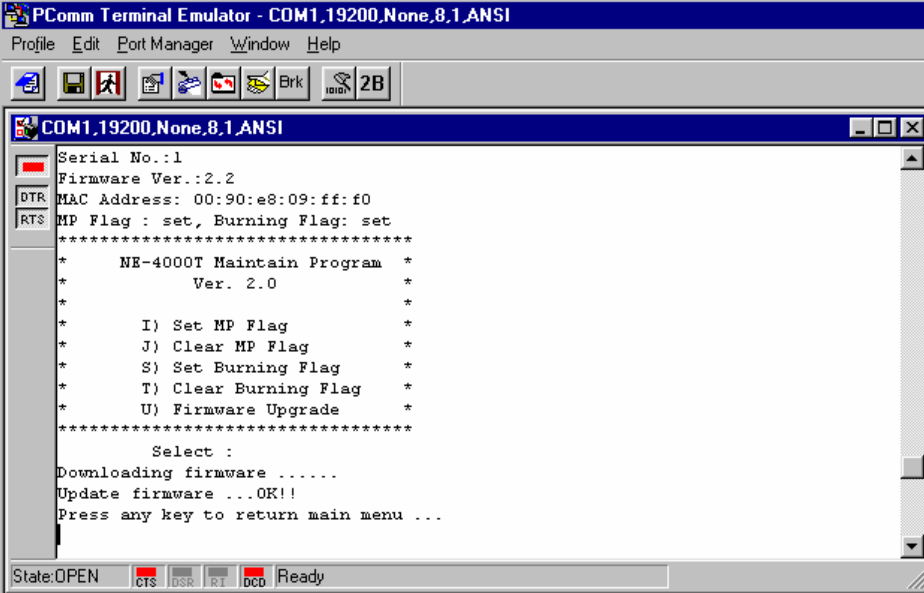

The screenshot shows a terminal window titled "PComm Terminal Emulator - COM1,19200,None,8.1,ANSI". The window contains the following text:

```
Serial No.:1
Firmware Ver.:2.2
MAC Address: 00:90:e8:09:ff:f0
MP Flag : set, Burning Flag: set
*****
*   NE-400T Maintain Program   *
*           Ver. 2.0           *
*                               *
*   I) Set MP Flag             *
*   J) Clear MP Flag           *
*   S) Set Burning Flag        *
*   T) Clear Burning Flag      *
*   U) Firmware Upgrade        *
*****
Select :
Downloading firmware .....
Update firmware ...OK!!
Press any key to return main menu ...
```

At the bottom of the terminal window, the status bar shows "State:OPEN" and "Ready" with indicators for CTS, DSR, RI, and DCD.

A

Well Known Port Numbers

This appendix is for your reference. Listed below are Well Known Port Numbers that may cause network problems if you configure NE-4000T for the same port. Refer to RFC 1700 for Well Known Port Numbers or refer to the following introduction from IANA.

The port numbers are divided into three ranges: the Well Known Ports, the Registered Ports, and the Dynamic and/or Private Ports.

- The Well Known Ports range from 0 through 1023.
- The Registered Ports range from 1024 through 49151.
- The Dynamic and/or Private Ports range from 49152 through 65535.

The Well Known Ports are assigned by IANA, and on most systems, can only be used by system processes or by programs executed by privileged users. The following table shows famous port numbers among the well-known port numbers. For more details, please visit the IANA website at <http://www.iana.org/assignments/port-numbers>

TCP Socket	Application Service
0	reserved
1	TCP Port Service Multiplexor
2	Management Utility
7	Echo
9	Discard
11	Active Users (systat)
13	Daytime
15	Netstat
20	FTP data port
21	FTP CONTROL port
23	Telnet
25	SMTP (Simple Mail Transfer Protocol)
37	Time (Time Server)
42	Host name server (names server)
43	Whois (nickname)

TCP Socket	Application Service
49	(Login Host Protocol) (Login)
53	Domain Name Server (domain)
79	Finger protocol (Finger)
80	World Wide Web HTTP
119	Network news Transfer Protocol (NNTP)
123	Network Time Protocol
213	IPX
160 – 223	Reserved for future use

UDP Socket	Application Service
0	reserved
2	Management Utility
7	Echo
9	Discard
11	Active Users (systat)
13	Daytime
35	Any private printer server
39	Resource Location Protocol
42	Host name server (names server)
43	Whois (nickname)
49	(Login Host Protocol) (Login)
53	Domain Name Server (domain)
69	Trivial Transfer Protocol (TFTP)
70	Gopher Protocol
79	Finger Protocol
80	World Wide Web HTTP
107	Remote Telnet Service
111	Sun Remote Procedure Call (Sunrpc)
119	Network news Transfer Protocol (NNTP)
123	Network Time protocol (ntp)
161	SNMP (Simple Network Mail Protocol)
162	SNMP Traps
213	IPX (Used for IP Tunneling)

B

NECI Library

NECI (Network Enabler Configuration Interface) is a set of APIs that run in the Windows 95/98/ME/NT/2000/XP system to search, locate, and configure the NE-4000T over the network. The NE-4000T library can be found in the folder **.\NECI_LIBRARY** on the CD enclosed with NE-4000T product. For more information, refer to svrctl.chm in that directory.

C

DIO Commands

In this appendix, we give the reference DIO commands used to access the Digital I/O status of the NE-4000T Network Enabler from an Ethernet network. The Digital I/O status can be accessed by a specific TCP port (default 5001) on the Network Enabler.

Command Packet Format:

Length (Bytes)	1	1	1	1 – 255
Format	Command	Version {must be 1 (hex)}	Length (of data)	Data

Send the Command packet to the Network Enabler. The “Data” field is command specific.

ACK Packet Format:

Length (Bytes)	1	1	1	1 -255
Format	Command	Command Status	Length (of data)	Data

The Network Enabler returns by ACK packet. You can get the Digital I/O status and input/output operation mode by checking the “Data” field of the packet.

Command: This field defines the command code. For example, 1 (hex) represents “read single DIO.” For more information, refer to following content.

Command Status: This field returns the status of the command.

- 1 – OK
- 0 – Command error; may be unknown

Data Structure Definition:

C code example:

```
//define header length of DIO Packet
#define HEADER_LEN 3 // 3 bytes
//define DIO Packet format
//Used for Command and ACK packet
typedef struct _DIO_Packet_Struct {
    char    command;
    char    version;
    char    length;
    char    data[255];
} DIOPacketStruct, *pDIOPacketStruct;
```

Command Code Usage

1. Reading Single DIO

Read the state (“high” or “low”) and the mode (“in” or “out”) of the single digital I/O point.

Parameters:

Command code: 1 (hex)

Version: 1 (hex)

Length of data: 1 (hex), represents one byte.

data[0]: Fill in the number for the DIO you wish to access. DIO numbers start from 0 (hex).

Return:

Command Status: Check the Command Status code on the previous page.

Length of data: 3 (hex). Must be 3 bytes of return code in this mode.

data[0]: The number for the DIO you wish to access.

data[1]: DIO mode (hex), 0 for IN, 1 for OUT

data[2]: DIO status (hex), 0 for LOW, 1 for HIGH

C code example:

```

BOOL ReadSingleDIO(int port, int *mode, int *status)
{
    DIOPacketStruct packet;

    packet.command = 1;    // read single DIO command
    packet.version = 1;    // DIO protocol version
    packet.length = 1;    // data length
    packet.data[0] = (char)port;    // DIO Number
    send(SocketFd, (char *)&packet, HEADER_LEN+packet.length, 0);
    //Send TCP Packet
    // Process the returned data here.
    return TRUE;
}

```

2. Writing Single DIO Mode

Set the operation mode of a single digital I/O point to “input” or “output.”

Parameters:

Command code: 2 (hex)

Version: 1 (hex)

Length of data: 2 (hex); represents three bytes.

data[0]: The number for the DIO you wish to access.

data[1]: DIO mode (hex), 0 for IN, 1 for OUT

Return:

Command Status: Check the Command Status code on the previous page.

Length of data: 3 (hex). Must be 3 bytes of return code in this mode.

data[0]: The number for the DIO you wish to access.

data[1]: DIO mode (hex), 0 for IN, 1 for OUT

data[2]: DIO status (hex), 0 for LOW, 1 for HIGH

C code example:

```
void WriteSingleDIOMode(int port, int mode)
{
    DIOPacketStruct packet;

    packet.command = 2;    // write single DIO mode command
    packet.version = 1;    // DIO protocol version
    packet.length = 2;    // data length
    packet.data[0] = (char)port;    // DIO number
    packet.data[1] = (char)mode;    // DIO mode
    send(SocketFd, (char *)&packet, HEADER_LEN+packet.lenght, 0);
    //Send TCP packet
    //Process the returned data here
}
```

3. Writing a Single DIO Status

Set the status of the single digital output point to “high” or “low” state.

Parameters:

Command code: 3 (hex)

Version: 1 (hex)

Length of data: 2 (hex); represents three bytes.

data[0]: The number for the DIO you wish to access.

data[1]: DIO status (hex), 0 for LOW, 1 for HIGH

Return:

Command Status: Check the Command Status code on the previous page.

Length of data: 3 (hex). Must be 3 bytes of return code in this mode.

data[0]: The number for the DIO you wish to access.

data[1]: DIO mode (hex), 0 for IN, 1 for OUT

data[2]: DIO status (hex), 0 for LOW, 1 for HIGH

C code example:

```
void WriteSingleDIOStatus(int port, int status)
{
    DIOPacketStruct packet;

    packet.command = 3;    // write single DIO status command
    packet.version = 1;    // DIO protocol version
    packet.length = 2;    // data length
    packet.data[0] = (char)port;    // DIO number
    packet.data[1] = (char)status;    // DIO status
    send(SocketFd, (char *)&packet, HEADER_LEN+packet.lenght, 0);
    //Send TCP packet
    //Process the returned data here
}
```

4. Reading Multiple DIOs

Read the state (“high” or “low”) and the mode (“in” or “out”) of all digital I/O points at the same time.

Parameter:

Command code: 4 (hex)

Version: 1 (hex)

Length of data: 1 (hex); represents two bytes.

data[0]: Number of the DIO port you wish to access.

Note:Port0 (DIO0, DIO1,...,DIO7), Port1 (DIO8,DIO9,...,DIO15), etc.

Return:

Command Status : Check the Command Status code on the previous page.

Length of data: 17

data[0]: no. of DIO Port

data[1]: mode of 1st DIO for specific DIO port

data[2]: status of 1st DIO for specific DIO port

data[3]: mode of 2nd DIO for specific DIO port

data[4]: status of 2nd DIO for specific DIO port

....

data[15]: mode of 8th DIO for specific DIO port

data[16]: status of 8th DIO for specific DIO port

C code example:

```

BOOL    ReadMultipleDIO(int port, int *mode, int *status)
{
    DIOPacketStruct packet;

    packet.command = 4;           // Read Byte DIO Commands
    packet.version = 1;          // DIO protocol command version
    packet.length = 1;           // data length
    packet.data[0] = port;       // DIO port
    send(SocketFd, (char *)&packet, HEAD_LEN+packet.length, 0);
    //Send TCP packet
    //Process the returned data here
    return TRUE;
}

```

Note: The NE-4000T Documentation & Software CD-ROM contains a utility that can be used to test the DIO access commands.