

# Universal PCI Board User's Manual

---

Multiport Serial Board for PCI and PCI-X Bus

Eighth Edition, July 2012

[www.moxa.com/product](http://www.moxa.com/product)

**MOXA**<sup>®</sup>

© 2012 Moxa Inc. All rights reserved.

# Universal PCI Board User's Manual

The software described in this manual is furnished under a license agreement and may be used only in accordance with the terms of that agreement.

## Copyright Notice

© 2012 Moxa Inc. All rights reserved.

## Trademarks

The MOXA logo is a registered trademark of Moxa Inc.  
All other trademarks or registered marks in this manual belong to their respective manufacturers.

## Disclaimer

Information in this document is subject to change without notice and does not represent a commitment on the part of Moxa.

Moxa provides this document as is, without warranty of any kind, either expressed or implied, including, but not limited to, its particular purpose. Moxa reserves the right to make improvements and/or changes to this manual, or to the products and/or the programs described in this manual, at any time.

Information provided in this manual is intended to be accurate and reliable. However, Moxa assumes no responsibility for its use, or for any infringements on the rights of third parties that may result from its use.

This product might include unintentional technical or typographical errors. Changes are periodically made to the information herein to correct such errors, and these changes are incorporated into new editions of the publication.

## Technical Support Contact Information

[www.moxa.com/support](http://www.moxa.com/support)

### **Moxa Americas**

Toll-free: 1-888-669-2872  
Tel: +1-714-528-6777  
Fax: +1-714-528-6778

### **Moxa Europe**

Tel: +49-89-3 70 03 99-0  
Fax: +49-89-3 70 03 99-99

### **Moxa India**

Tel: +91-80-4172-9088  
Fax: +91-80-4132-1045

### **Moxa China (Shanghai office)**

Toll-free: 800-820-5036  
Tel: +86-21-5258-9955  
Fax: +86-21-5258-5505

### **Moxa Asia-Pacific**

Tel: +886-2-8919-1230  
Fax: +886-2-8919-1231

# Table of Contents

<b>1. Introduction</b>	<b>1-1</b>
Overview	1-2
Applications	1-4
Package Checklist	1-4
Product Features	1-5
Product Specifications	1-5
Installation Guide	1-7
<b>2. Hardware Installation</b>	<b>2-1</b>
Overview	2-2
Configuring the Board and Dimension	2-2
CP-118U/CP-118U-I	2-2
CP-138U/CP-138U-I	2-3
CP-168U	2-5
CP-114UL/CP-114UL-I	2-5
CP-134U/CP-134U-I	2-7
CP-104UL	2-8
CP-104JU	2-9
POS-104UL	2-9
CP-112UL/CP-112UL-I	2-10
CP-132UL/CP-132UL-I	2-11
CP-102UL	2-12
CP-102U	2-12
CP-102UF	2-13
Plugging the Board into an Expansion Slot	2-14
<b>3. Driver Installation: Windows Vista/2008</b>	<b>3-1</b>
Overview	3-2
Installing the Driver	3-3
Installing the Ports	3-6
Verifying the Installation	3-9
Configuring the Ports	3-11
Disabling the Board	3-12
Uninstalling the Board	3-13
<b>4. Driver Installation: Windows XP/2003</b>	<b>4-1</b>
Overview	4-2
Installing the Driver	4-3
Installing the Ports	4-6
Verifying the Installation	4-9
Configuring the Ports	4-11
Using PComm	4-12
Using Event Log	4-12
Disabling the Board	4-13
Uninstalling the Board	4-14
<b>5. Driver Installation: Windows 2000</b>	<b>5-1</b>
Overview	5-2
Installing the Driver	5-3
Installing the Ports	5-6
Verifying the Installation	5-8
Configuring the Ports	5-10
Using PComm	5-11
Using Event Log	5-11
Disabling the Board	5-12
Uninstalling the Board	5-13
<b>6. Driver Installation: Windows NT</b>	<b>6-1</b>
Overview	6-2
Installing the Driver	6-3
Configuring the Ports	6-6
Removing the Board	6-8
Updating the Driver	6-8
Removing the Driver	6-9
<b>7. Driver Installation: Windows 95/98/ME</b>	<b>7-1</b>
Overview	7-2
Installing the Driver	7-3
Windows 95	7-3
Windows 98 and ME	7-4
Configuring the Ports	7-7
Updating the Driver	7-9

Removing the Driver .....	7-11
<b>8. Driver Installation: Windows CE.....</b>	<b>8-1</b>
Windows CE 5.0 .....	8-2
Installing the Driver.....	8-2
Windows CE 6.0 Installation.....	8-7
<b>9. Driver Installation: Non Windows .....</b>	<b>9-1</b>
Overview .....	9-2
DOS .....	9-2
Installing the Driver.....	9-2
Setting up the Driver .....	9-3
Loading the Driver.....	9-5
Unloading the Driver.....	9-5
Linux (32-bit/64-bit) .....	9-6
SCO.....	9-6
<b>10. Serial Programming Tools .....</b>	<b>10-1</b>
Overview .....	10-2
Serial Programming Library.....	10-2
PComm Utilities.....	10-2
Installation .....	10-2
PComm Diagnostic .....	10-3
PComm Monitor .....	10-3
PComm Terminal Emulator .....	10-4
<b>11. Pin Assignments.....</b>	<b>11-1</b>
Overview .....	11-2
CP-102U.....	11-3
DB9 (Male): RS-232 .....	11-3
CP-102UL .....	11-3
DB25 (Female): RS-232 .....	11-3
CP-104JU.....	11-4
8-pin RJ45: RS-232 .....	11-4
CP-104UL .....	11-5
DB44 (Female): RS-232 .....	11-5
CP-112UL .....	11-5
DB25 (Female): RS-232 .....	11-5
DB25 (Female): RS-422.....	11-6
DB25 (Female): RS-485 (4-wire).....	11-6
DB25 (Female): RS-485 (2-wire).....	11-6
CP-114UL .....	11-7
DB44 (Female): RS-232 .....	11-7
DB44 (Female): RS-422, RS-485 (4-wire) .....	11-7
DB44 (Female): RS-485 (2-wire).....	11-8
CP-118U.....	11-8
DB62 (Female): RS-232 .....	11-9
DB62 (Female): RS-422, RS-485 (4-wire) .....	11-9
DB62 (Female): RS-485 (2-wire).....	11-10
CP-118U-I .....	11-11
DB78 (Female): RS-232 .....	11-11
DB78 (Female): RS-422, RS-485 (4-wire) .....	11-12
DB78 (Female): RS-485 (2-wire).....	11-12
CP-132UL, CP-132UL-I .....	11-13
DB25 (Female): RS-422 .....	11-13
DB25 (Female): RS-485 (4-wire).....	11-13
DB25 (Female): RS-485 (2-wire).....	11-14
CP-134U, CP-134U-I .....	11-14
DB44 (Female): RS-232 (Ports 1 and 2 only) .....	11-14
DB44 (Female): RS-422.....	11-15
DB44 (Female): RS-485 (4-wire).....	11-15
DB44 (Female): RS-485 (2-wire).....	11-16
CP-138U.....	11-16
DB62 (Female): RS-422, RS-485 (4-wire) .....	11-17
DB62 (Female): RS-485 (2-wire).....	11-17
CP-138U-I .....	11-18
DB78 (Female): RS-422, RS-485 (4-wire) .....	11-18
DB78 (Female): RS-485 (2-wire).....	11-19
CP-168U.....	11-19
DB62 (Female): RS-232 .....	11-20
POS-104UL .....	11-20
DB44 (Female): RS-232 .....	11-20
CP-102UF .....	11-21
Serial Connectors .....	11-21

DB9 (Male) .....	11-21
DB25 (Male) .....	11-22
DB25 (Female).....	11-22
RJ45 .....	11-23

# Introduction

---

The following topics are covered in this chapter:

- ❑ **Overview**
  - Applications
- ❑ **Package Checklist**
- ❑ **Product Features**
- ❑ **Product Specifications**
- ❑ **Installation Guide**

## Overview

Moxa Universal PCI (UPCI) multiport serial boards can be installed in PCI or PCI-X slots, and support both 3.3V and 5V PCI/PCI-X. With a UPCI board, you can connect data acquisition equipment and other serial devices to your PC over RS-232, RS-422, or RS-485. Each board has on-chip hardware and software flow control, a built-in 128-byte Tx/Rx FIFO, and well-designed device drivers that have been fine-tuned. This allows Moxa UPCI boards to support data transmission speeds of up to 921.6 Kbps.

The following UPCI multiport serial boards are available from Moxa:

### 8 Ports

<b>CP-118U:</b>	8 ports, RS-232/422/485
<b>CP-118U-T:</b>	8 ports, RS-232/422/485, wide temperature
<b>CP-118U-I:</b>	8 ports, RS-232/422/485, 2KV optical isolation
<b>CP-118-U-I-T:</b>	8 ports, RS-232/422/485, 2KV optical isolation, wide temperature
<b>CP-138U:</b>	8 ports, RS-422/485
<b>CP-138-T:</b>	8 ports, RS-422/485, wide temperature
<b>CP-138-I:</b>	8 ports, RS-422/485, 2KV optical isolation, wide temperature
<b>CP-138-U-T-I:</b>	8 ports, RS-422/485, 2KV optical isolation
<b>CP-168U:</b>	8 ports, RS-232
<b>CP-168U-T:</b>	8 ports, RS-232, wide temperature

### 4 Ports

<b>CP-114UL:</b>	4 ports, RS-232/422/485, low profile
<b>CP-114UL-T:</b>	4 ports, RS-232/422/485, low profile, wide temperature
<b>CP-114UL-I:</b>	4 ports, RS-232/422/485, low profile, 2KV optical isolation
<b>CP-114UL-I-T:</b>	4 ports, RS-232/422/485, low profile, , 2KV optical isolation, wide temperature
<b>CP-134U:</b>	4 ports, RS-422/485
<b>CP-134U-T:</b>	4 ports, RS-422/485, wide temperature
<b>CP-134U-I:</b>	4 ports, RS-422/485, 2KV optical isolation
<b>CP-134U-I-T:</b>	4 ports, RS-422/485, 2KV optical isolation, wide temperature
<b>CP-104UL:</b>	4 ports, RS-232, low profile
<b>CP-104UL-T:</b>	4 ports, RS-232, low profile, wide temperature
<b>CP-104JU:</b>	4 ports, RS-232, 8-pin RJ45 connector on-board
<b>CP-104JU-T:</b>	4 ports, RS-232, 8-pin RJ45 connector on-board, wide temperature
<b>POS-104UL:</b>	4 ports, RS-232, low profile, serial port powered
<b>POS-104UL-T:</b>	4 ports, RS-232, low profile, serial port powered, wide temperature

### 2 Ports

<b>CP-112UL:</b>	2 ports, RS-232/422/485, low profile
<b>CP-112UL-T:</b>	2 ports, RS-232/422/485, low profile, wide temperature
<b>CP-112UL-I:</b>	2 ports, RS-232/422/485, low profile, 2KV optical isolation
<b>CP-112UL-I-T:</b>	2 ports, RS-232/422/485, low profile, 2KV optical isolation
<b>CP-132UL:</b>	2 ports, RS-422/485, low profile
<b>CP-132UL-T:</b>	2 ports, RS-422/485, low profile, wide temperature
<b>CP-132UL-I:</b>	2 ports, RS-422/485, low profile, 2KV optical isolation
<b>CP-132UL-I-T:</b>	2 ports, RS-422/485, low profile, 2KV optical isolation, wide temperature
<b>CP-102UL:</b>	2 ports, RS-232, low profile
<b>CP-102UL-T:</b>	2 ports, RS-232, low profile, wide temperature
<b>CP-102U:</b>	2 ports, RS-232
<b>CP-102U-T:</b>	2 ports, RS-232, wide temperature
<b>CP-102UF:</b>	2 ports, Serial-over-fiber board

## Smartio—The Smart Multiport Async Solution

The Smartio Series of multiport serial boards includes the CP-168U, CP-104UL, CP-104JU, POS-104UL, CP-102UL, and CP-102U. These boards provide RS-232 serial ports for connecting terminals, modems, printers, scanners, cash registers, bar code readers, keypads, numeric displays, electrical scales, data acquisition equipment, and many other serial devices to a PC. These boards are a reliable, high-performance solution for multiport serial communication.

## Industio—The Industrial Multiport Async Solution

The Industio Series of multiport serial boards includes the CP-118U-I, CP-118U, CP-138U-I, CP-138U, CP-114UL, CP134U, CP-134U-I, CP-132UL, and CP-132UL-I. These boards are designed for industrial use, with serial ports that can be configured independently for RS-232, RS-422, or RS-485 operation. Industio boards provide a reliable communication link over distances of up to 4000 ft and support point-to-point full-duplex or multi-drop half-duplex. With RS-485 operation, a single port can connect to 32 devices in a multi-drop environment.

## ADDC™ (Automatic Data Direction Control) for RS-485

ADDC™ (Automatic Data Direction Control) makes it easier to manage 2-wire RS-485 half-duplex connections, eliminating the need for software interference. This means that it is not necessary to write extra code for Windows applications to control the half-duplex protocol. ADDC intelligence is built into Industio boards.

## Serial-over-fiber Board

The CP-102UF is a serial-over-fiber board designed for industrial automation applications that require a long distance, multi-point, PC-based data acquisition solution. The single-mode model (CP-102UF-S) can transmit up to 40 km, and the multi-mode model (CP-102UF-M) can transmit up to 5 km. For many industrial applications, an even bigger benefit is that optical fiber isolates the data from dangerous increases in ground potential, ground loops, and electrical EMI/RFI electromagnetic radiation.

## Built-in Termination Resistors for RS-422 and RS-485

Industio boards have termination resistors built-in, eliminating the headaches involved in determining the proper impedance for the resistors. For additional information, please refer to Chapter 2.

## ESD and Isolation Protection

Certain models include TVSS (Transient Voltage Surge Suppressor) technology to help prevent damage due to lightning or high potential voltage. Optical isolation (2000V) and embedded protection (max. ESD of 16 KV, max. EFT of 2 KV) are also available with certain models. These features help provide protection in critical or harsh factory-type environments.

## PCI Solution

UPCI boards comply with PCI Spec. 2.1 and do not require switches or jumpers. IRQ and I/O address is automatically assigned by the PCI BIOS. This means that the board must be physically installed in the computer first before the driver software is installed.



## Universal PCI

For maximum compatibility with the PCI local bus specification, UPCI boards support both 3.3V and 5V PCI connector types. The 32/64-bit PCI local bus specification specifies both a 3.3V/5V and 32/64-bit slot.

## Operating System Support

Moxa UPCI boards are compatible with most major industrial platforms, including Windows, DOS, and Linux. Drivers are provided for smoother installation, configuration, and performance. This manual provides separate sections for the different operating systems that are supported.

## Moxa Serial Communication Tools

For application development, Moxa provides a serial communication library for Windows called PComm. This library can help you develop your own applications in Visual Basic, Visual C++, Borland Delphi, and more. Utilities are included for debugging, monitoring communication status, terminal emulation, and file transfer.

## Applications

UPCI boards are suitable for many industrial applications, including the following:

- Multipoint data acquisition
- Factory automation
- Critical industrial control
- Remote serial device control
- Internet/intranet connections
- Remote access applications
- Multi-user applications
- Industrial automation
- Office automation
- Telecommunications
- PC-based vending machines or kiosk systems
- POS (Point-of-Sale) systems

## Package Checklist

UPCI boards are shipped with the following items:

- 1 Moxa UPCI multipoint serial board
- Low profile bracket (low profile models only)
- Document & Software CD
- Quick Installation Guide
- 5-year Product Warranty statement

NOTE: Notify your sales representative if any of the above items is missing or damaged. For information on optional accessories for each model, please refer to Chapter 5.

## Product Features

Moxa UPCI boards enjoy the following features:

- Over 700 Kbps data throughput for top performance
- Serial communication speed up to 921.6 Kbps
- 128-byte FIFO and on-chip hardware and software flow control
- Universal PCI supporting 3.3V PCI, 5V PCI and PCI-X
- Driver support for Windows, Windows CE, Windows XP Embedded, DOS, Linux, FreeBSD, QNX SCO OpenServer, UnixWare7
- On-board 15 KV ESD protection
- Low profile for compact-sized PCs (on "L" models only)
- 2 KV optical isolation protection (on "I" models only)
- -40 to 85°C wide temperature (on "T" models only)

## Product Specifications

### Hardware

I/O Controller:	MU860 (compatible with 16C550C)	
Connector Type:	CP-118U-I:	Female DB78
	CP-118U:	Female DB62
	CP-138U-I:	Female DB78
	CP-138U:	Female DB62
	CP-168U :	Female DB62
	CP-114UL/ CP-114UL-I:	Female DB44
	CP-134U/CP-134U-I :	Female DB44
	CP-104UL :	Female DB44
	CP-104JU :	8-pin RJ45
	POS-104UL:	Female DB44
	CP-112UL/CP-112UL-I:	Female DB25
	CP-132UL/CP-112UL-I:	Female DB25
	CP-102UL:	Female DB25
	CP-102U:	Male DB9
	CP-114UL:	Female DB44
	CP-134U :	Female DB44
	CP-134U-I :	Female DB44
	CP-132UL :	Female DB25
	CP-132UL-I :	Female DB25
	CP-102UF:	ST type

**Interface**

Bus: 32-bit Universal PCI

No. of Ports: **8 Ports:**  
 CP-118U/CP-118U-I  
 CP-138U/CP-138U-I  
 CP-1168U

**4 Ports:**  
 CP-114UL/CP-114UL-I  
 CP-134U/CP-134U-I  
 CP-104UL/CP-104JU  
 POS-104UL:

**2 Ports:**  
 CP-112UL/CP-112UL-I  
 CP-132UL/CP-132UL-I  
 CP-102UL  
 CP-102U/CP-102UF

Max. No. of Boards: 4

**Signals**

RS-232: TxD, RxD, RTS, CTS, DTR, DSR, DCD, GND

RS-422: TxD+ (B), TxD- (A), RxD+ (B), RxD- (A), GND

4-wire RS-485: TxD+ (B), TxD- (A), RxD+ (B), RxD- (A), GND

2-wire RS-485: Data+ (B), Data- (A), GND

**Performance**

Baudrate: 50 bps to 921.6 Kbps

**Configuration**

Parity: None, Even, Odd, Space, Mark

Data Bits: 5, 6, 7, 8

Stop Bits: 1, 1.5, 2

I/O Address, IRQ: Assigned by BIOS

FIFO: 128 bytes

Flow Control: RTS/CTS, XON/XOFF

Driver Support: Windows 2000

Windows XP/2003/Vista/2008 (x86 & x64)

Linux 2.4

Linux 2.6 (x86 & x64)

Complete driver support information is available at [www.moxa.com](http://www.moxa.com) in the Download center.

Power Output: 5V/12V (POS-104UL only)

**Power and Environment**

Operating Temperature: 0 to 55°C (32 to 131°F)

Operating Humidity: 5 to 95% RH

Storage Temperature: -40 to 85°C (-40 to 185°F)

Protection: Embedded 15 KV ESD protection

**Certifications**

Approved: EN55022 Class B, EN55024, EN61000-3-2, EN61000-3-3, IEC61000-4-2, IEC61000-4-3, IEC61000-4-4, IEC61000-4-5, IEC61000-4-6, IEC61000-4-8, IEC61000-4-11, FCC Part 15 Class B

**Warranty**

5 years

# Installation Guide

UPCI board installation can be divided into six steps as follows:

- Step 1:** Select serial transmission mode.  
For certain models, you will need to set onboard DIP switches to select the serial transmission mode for each port. This applies to the CP-118U-I, CP-138U-I, CP-118U, CP-138U, CP-114UL, CP-114UL-I, CP-134U, CP-134U-I, CP-112UL, CP-112UL-I, CP-132UL, CP-132UL-I, POS-104UL, and CP-102UF. For details, please refer to Chapter 2.
- Step 2:** Install board.  
UPCI boards are installed in an open PCI or PCI-X expansion slot on the PC. For details, please refer to Chapter 2.
- Step 3:** Install drivers and configure board  
For details, please refer to Chapters 3 through 8.
- Step 4:** Connect your serial devices to the board's serial ports  
For details, please refer to Chapter 10.
- Step 5:** Restart system and verify driver initialization  
For details, please refer to Chapters 3 through 8.
- Step 6:** Develop and run your serial communication application  
For details, please refer to Chapter 9.

# Hardware Installation

---

The following topics are covered in this chapter:

▣ **Overview**

▣ **Configuring the Board and Dimension**

- CP-118U/CP-118U-I
- CP-138U/CP-138U-I
- CP-168U
- CP-114UL/CP-114UL-I
- CP-134U/CP-134U-I
- CP-104UL
- CP-104JU
- POS-104UL
- CP-112UL/CP-112UL-I
- CP-132UL/CP-132UL-I
- CP-102UL
- CP-102U
- CP-102UF

▣ **Plugging the Board into an Expansion Slot**

# Overview

This chapter explains the hardware installation procedure in detail. Since the BIOS automatically assigns the IRQ number and I/O addresses, you will need to install the board before you install the drivers. You can install up to 4 UPCI boards in one system, as long as sufficient I/O address and IRQ number resources are available.

## Configuring the Board and Dimension

### 8 Ports

### CP-118U/CP-118U-I

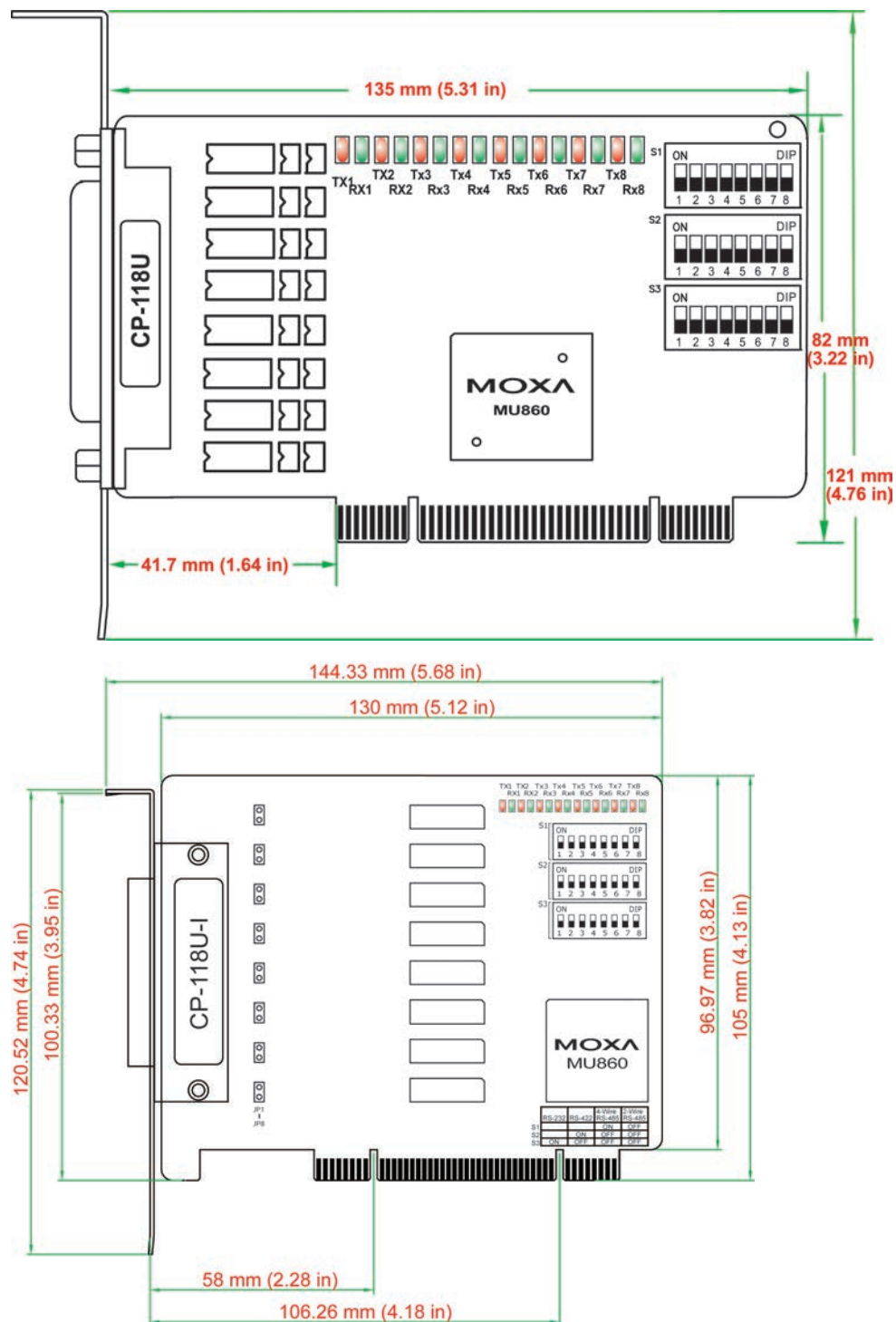

Onboard termination resistors can be activated individually for each serial port using jumpers JP1 through JP8. For CP-118U-I, JP1/2/3/4/5/6/7/8 corresponds to serial port 1/2/3/4/5/6/7/8, respectively. For CP-118U, JP1/2/3/4/5/6/7/8 corresponds to serial port 8/7/6/5/4/3/2/1, respectively. Short the jumper pins to activate the termination resistor; leave the jumper pins open to bypass the termination resistor.

The onboard DIP switches, S1, S2, and S3, are used to select RS-232, RS-422, or RS-485 mode for each serial port. There are 8 switches on each bank corresponding to the 8 serial ports. S3 selects between RS-232 and RS-422/485, S2 selects between RS-422 and RS-485, and S1 selects between 2-wire and 4-wire RS-485, as follows:

Mode	S1	S2	S3
RS-232	---	---	ON
RS-422	---	ON	OFF
4-wire RS-485	ON	OFF	OFF
2-wire RS-485	OFF	OFF	OFF

### CP-138U/CP-138U-I

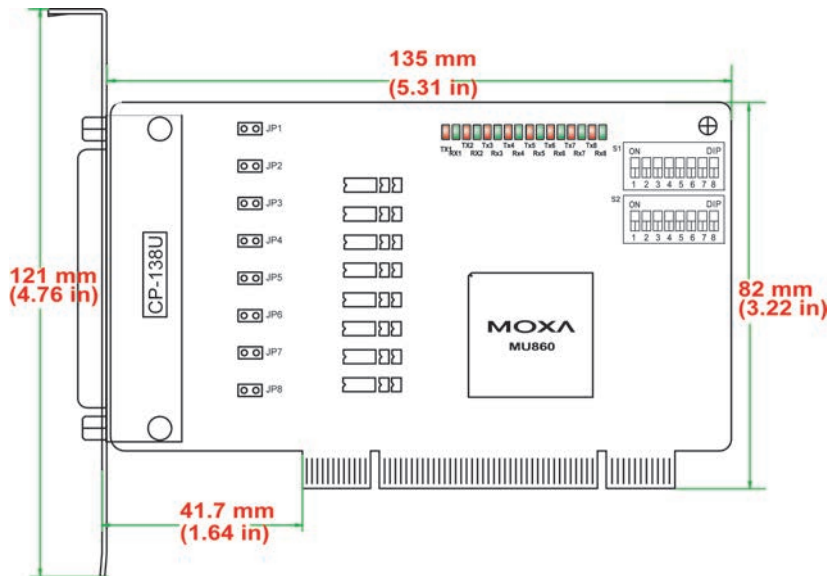

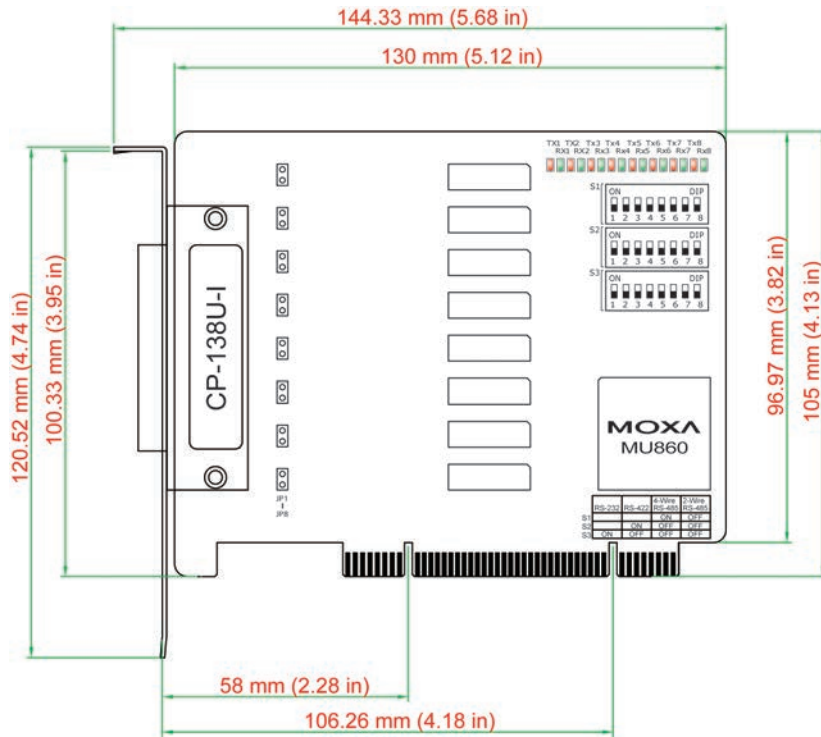

Onboard termination resistors can be activated individually for each serial port using jumpers JP1 through JP8. For CP-138U-I, JP1/2/3/4/5/6/7/8 corresponds to serial port 1/2/3/4/5/6/7/8, respectively. For CP-138U, JP1/2/3/4/5/6/7/8 corresponds to serial port 8/7/6/5/4/3/2/1, respectively. Short the jumper pins to activate the termination resistor; leave the jumper pins open to bypass the termination resistor.

The onboard DIP switches, S1 and S2, are used to select RS-422 or RS-485 mode for each serial port. There are 8 switches on each bank corresponding to the 8 serial ports. S2 selects between RS-422 and RS-485; S1 selects between 2-wire and 4-wire RS-485, as follows:

Mode	S1	S2
RS-422	---	ON
4-wire RS-485	ON	OFF
2-wire RS-485	OFF	OFF



### CP-168U

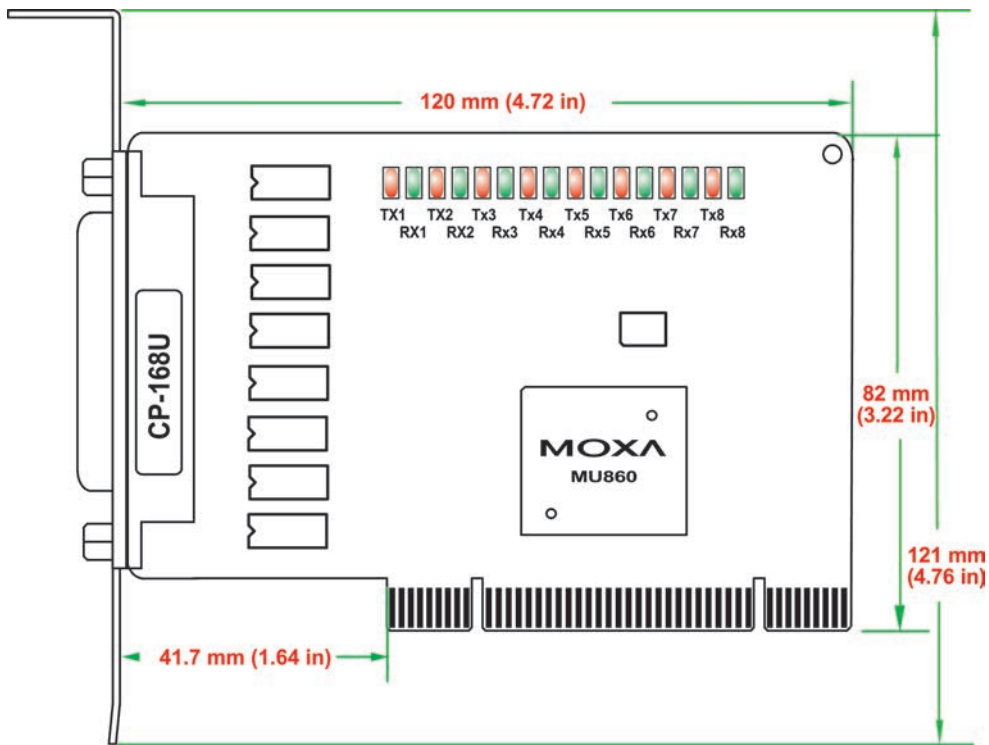

This board does not require configuration.

#### 4 Ports

### CP-114UL/CP-114UL-I

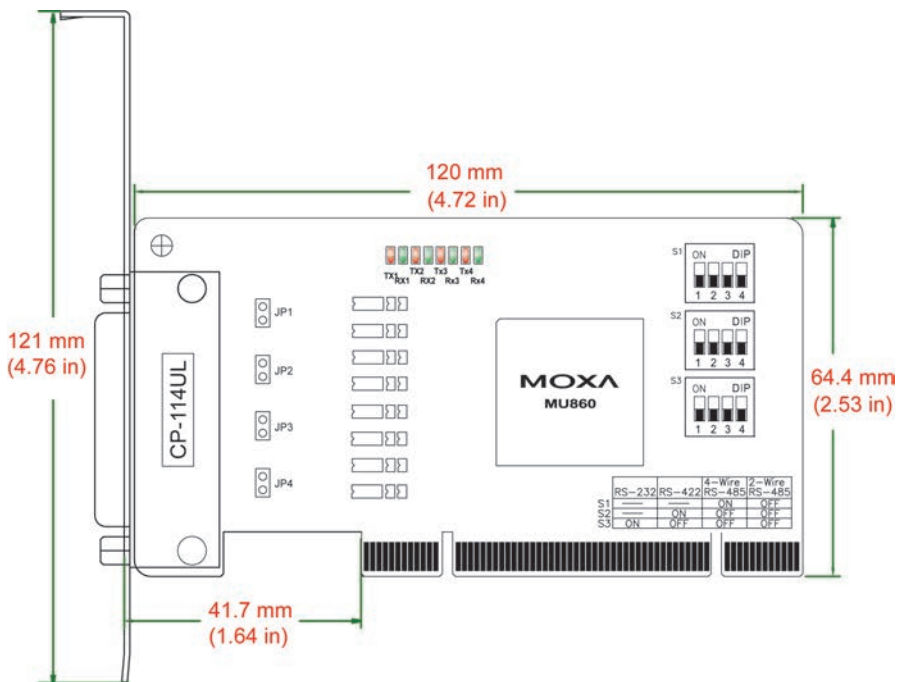

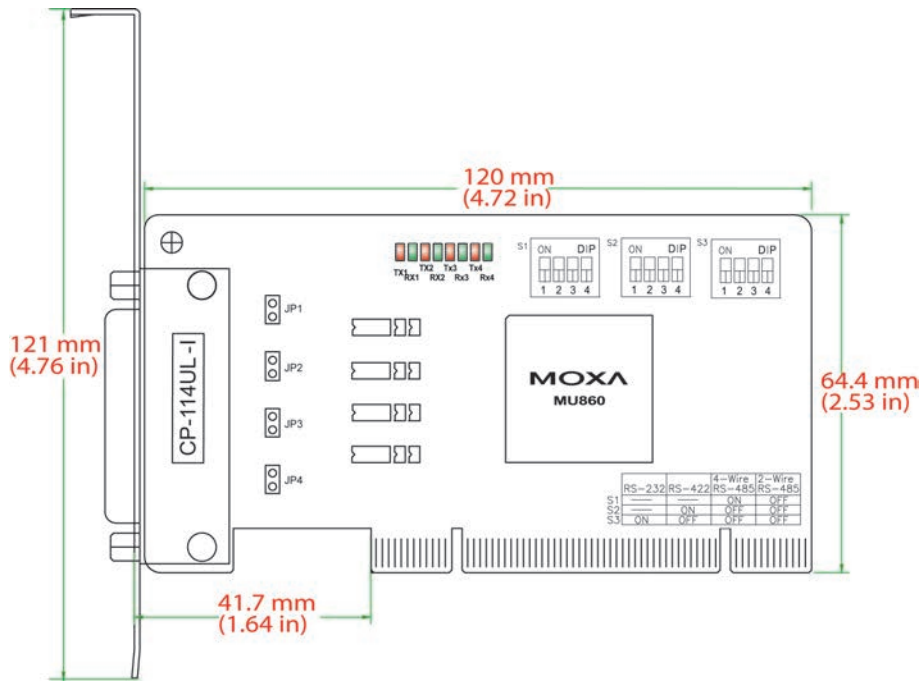

Onboard termination resistors can be activated individually for each serial port using jumpers JP1 through JP4. For CP-114UL, JP1/2/3/4 corresponds to serial port 1/2/3/4, respectively. For CP-114UL-I, JP1/2/3/4 corresponds to serial port 4/3/2/1, respectively. Short the jumper pins to activate the termination resistor; leave the jumper pins open to bypass the termination resistor.

The onboard DIP switches, S1, S2, and S3, are used to select RS-232, RS-422, or RS-485 mode for each serial port. Switches 1 through 4 on each bank correspond to the 4 serial ports. S3 selects between RS-232 and RS-422/485, S2 selects between RS-422 and RS-485, and S1 selects between 2-wire and 4-wire RS-485, as follows:

Mode	S1	S2	S3
RS-232	---	---	ON
RS-422	---	ON	OFF
4-wire RS-485	ON	OFF	OFF
2-wire RS-485	OFF	OFF	OFF

### CP-134U/CP-134U-I

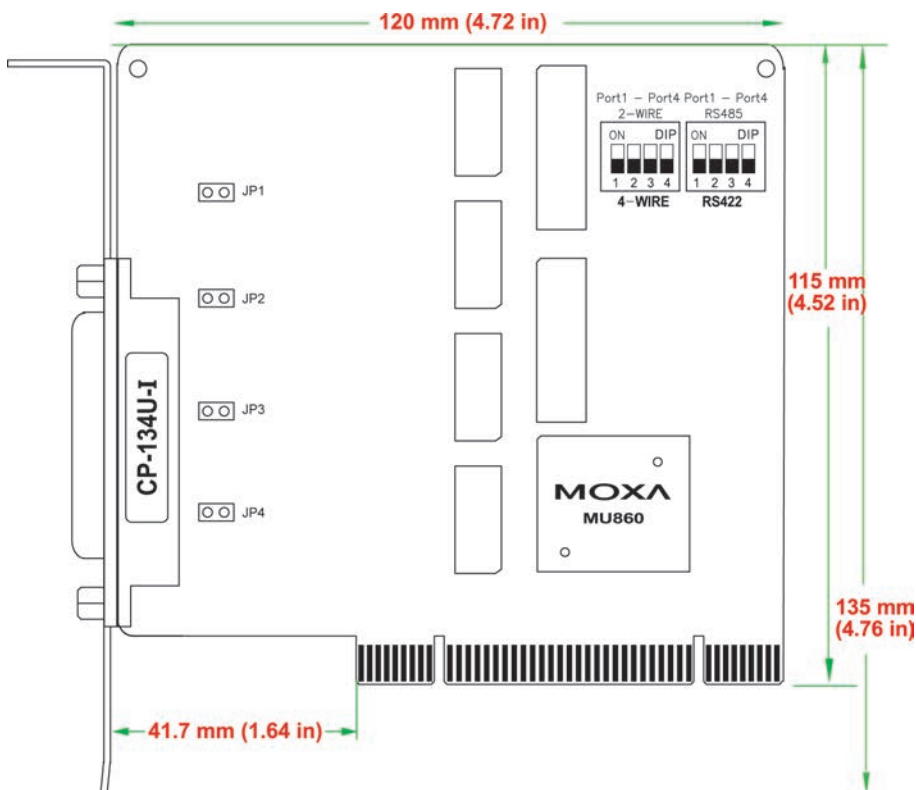
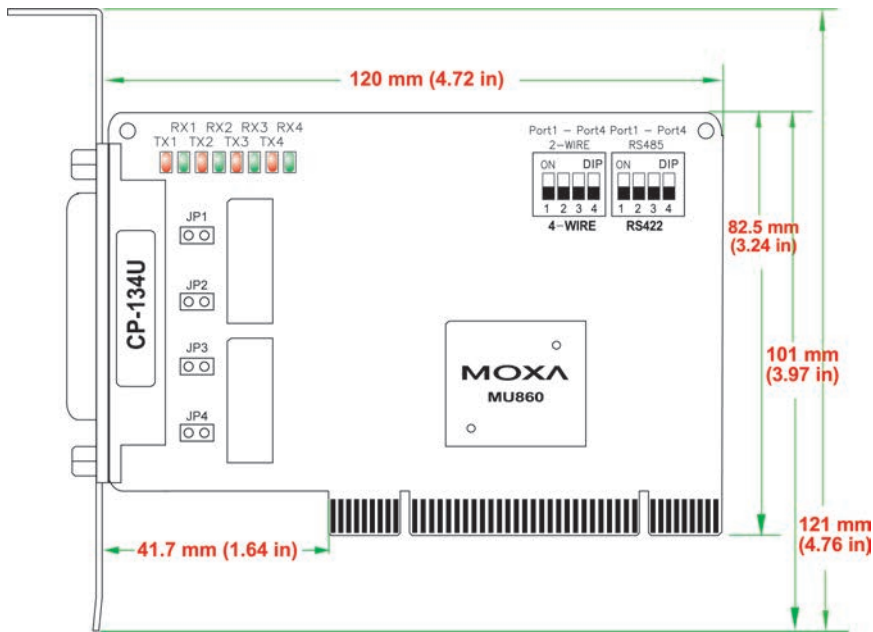

Onboard termination resistors can be activated individually for each serial port using jumpers JP1 through JP4. For CP-134U, JP1/2/3/4 corresponds to serial port 1/2/3/4, respectively. For CP-134U-I, JP1/2/3/4 corresponds to serial port 4/3/2/1, respectively. Short the jumper pins to activate the termination resistor; leave the jumper pins open to bypass the termination resistor.

The onboard DIP switches, S1 and S2, are used to select RS-422 or RS-485 mode for each serial port. Switches 1 through 4 on each bank correspond to the 4 serial ports. S2 selects between RS-422 and RS-485; S1 selects between 2-wire and 4-wire RS-485. In addition, ports 1 and 2 can be set individually to RS-232 mode using the on-board 30-pin jumpers, as follows:

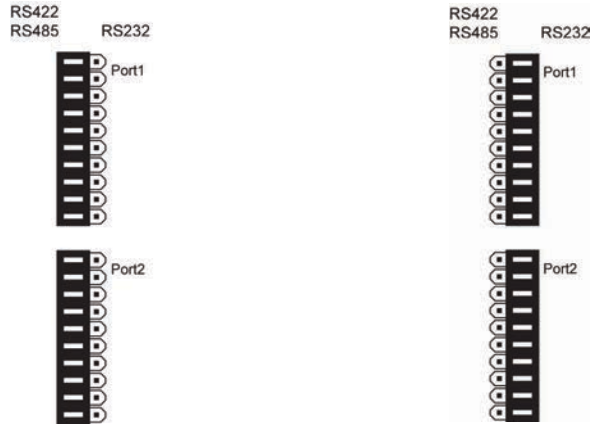

**RS-422 or RS-485 mode:**  
Use the jumper to cover the left two columns of jumper pins.

**RS-232 mode:**  
Use the jumper to cover the right two columns of jumper pins.

### CP-104UL

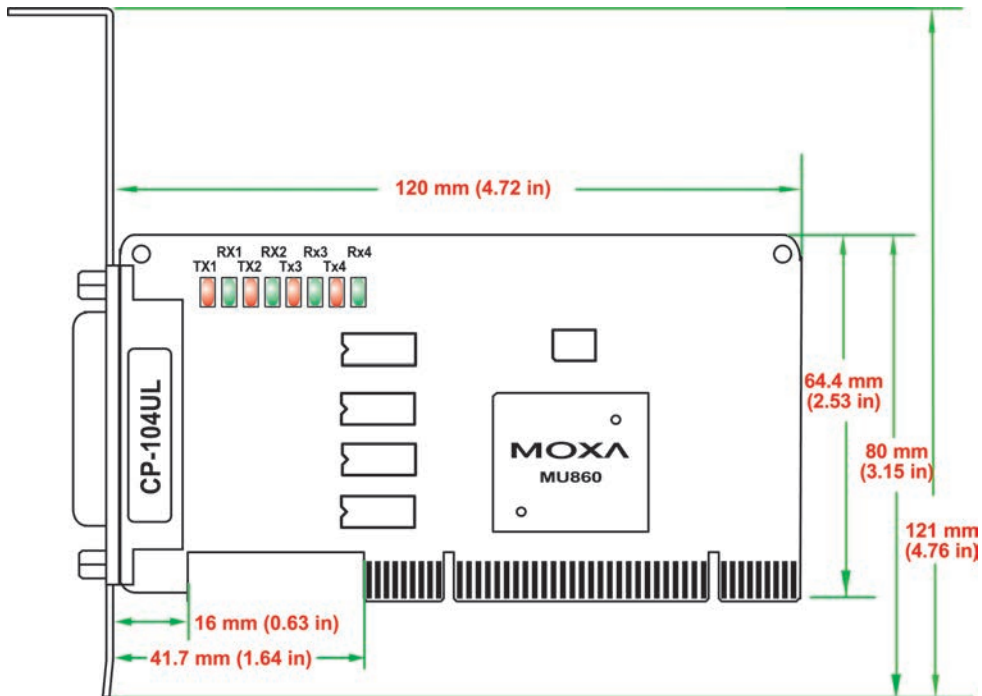

This board does not require configuration.

### CP-104JU

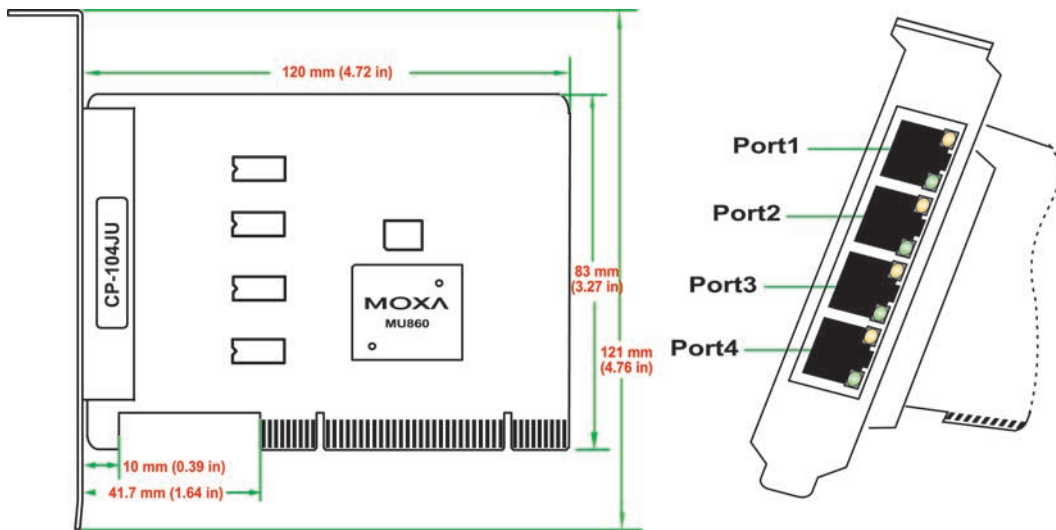

This board does not require configuration.

### POS-104UL

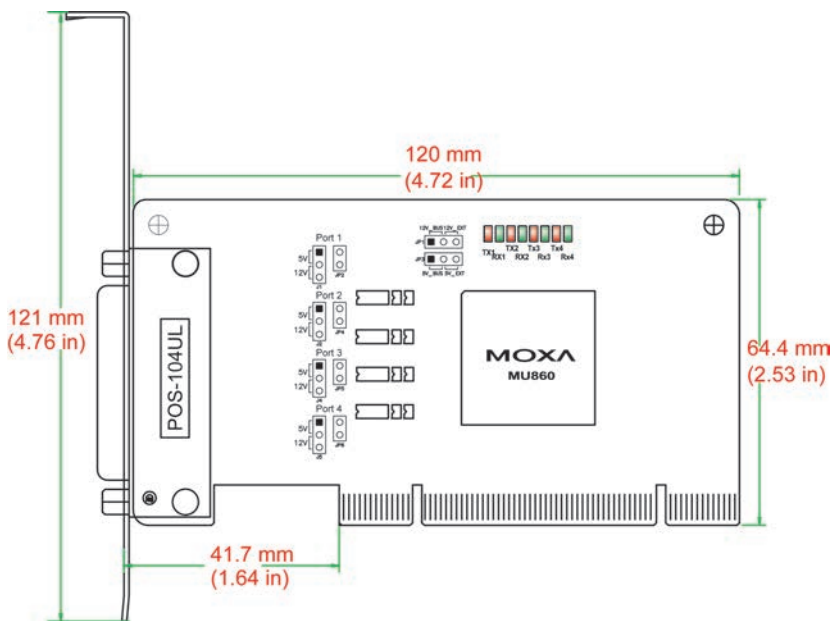

The onboard jumpers are used to specify the pin 9 power signal for each serial port.

**Step a**

The top row of jumper pins selects the source of 12V power; the bottom row of jumper pins selects the source of 5V power:

Bus power	External power

If 5V or 12V external power is enabled, you will need to connect the cable from the back of POS-104UL to the PC's power supply. Remove both jumpers to disable all power signals to all ports.

**Step b**

For each serial port, a set of 5 jumper pins is used select the power signal that is sent to pin 9.

5V	12V	RI signal (input)

To disable pin 9 power signals for a specific port, remove the jumper.

# CP-112UL/CP-112UL-I

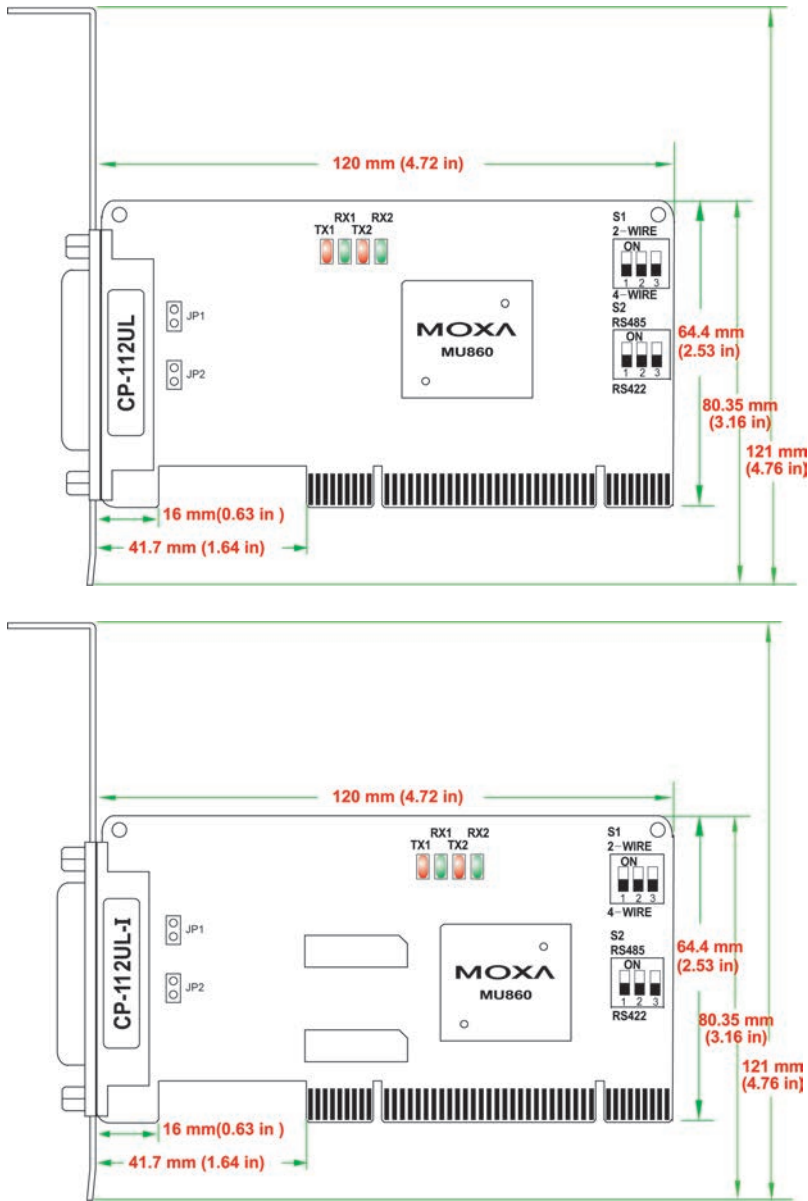

Onboard termination resistors can be activated individually for each serial port using jumpers JP1 and JP2. JP1 corresponds to serial port 1. Short the jumper pins to activate the termination resistor; leave the jumper pins open to bypass the termination resistor. The onboard DIP switches, S1, S2, and S3, are used to select RS-232, RS-422, or RS-485 mode for each serial port. Switch 1 corresponds to port 1 and switch 2 corresponds to port 2. S1 selects between RS-232, S2 selects between RS-422, and S3 selects between 2-wire and 4-wire RS-485, as follows:

Mode	S1	S2	S3
RS-232	ON	--	--
RS-422	OFF	ON	--
4-Wire RS-485	OFF	OFF	ON
2-Wire RS-485	OFF	OFF	OFF

# CP-132UL/CP-132UL-I

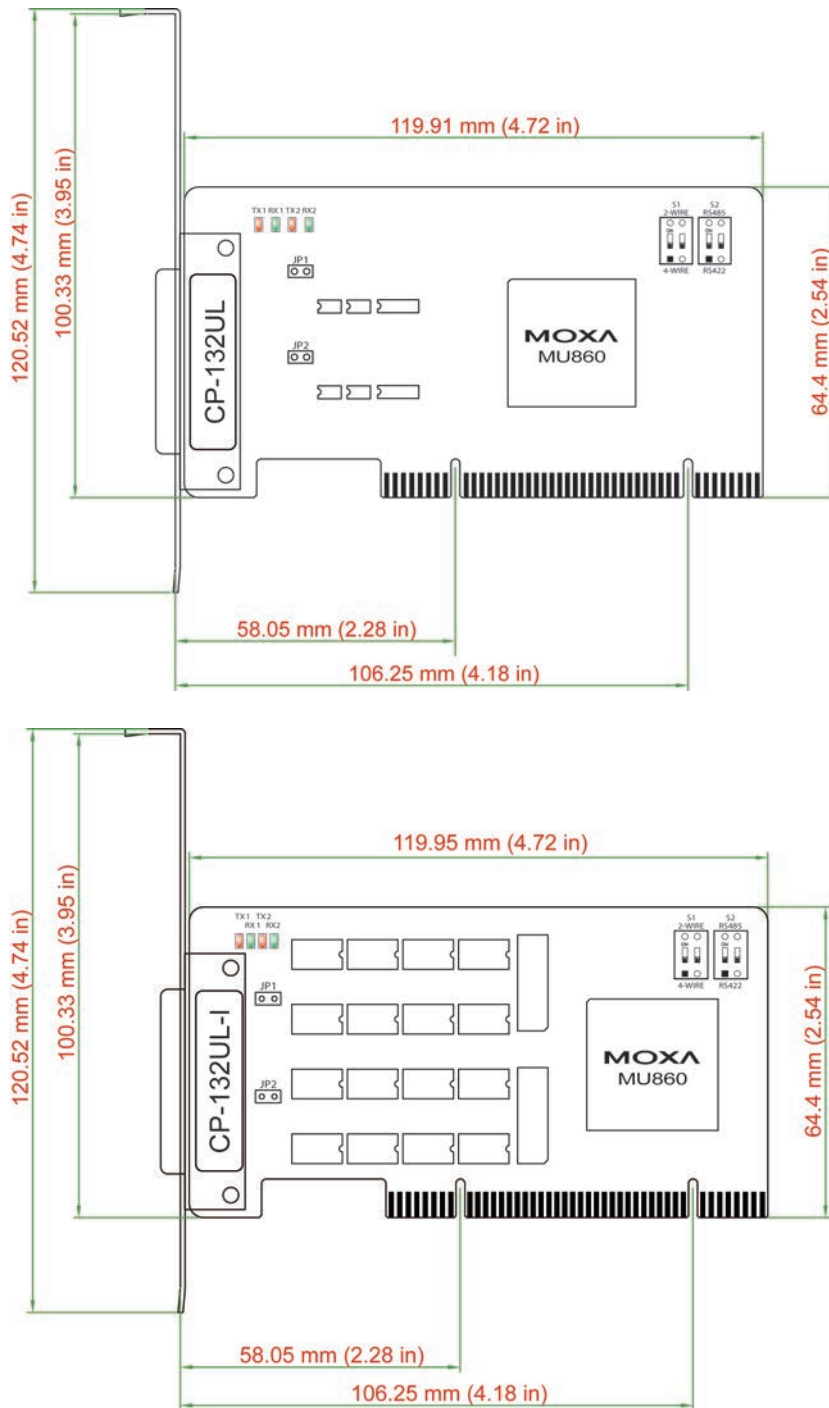

Onboard termination resistors can be activated individually for each serial port using jumpers JP1 and JP2. JP1 corresponds to serial port 1. Short the jumper pins to activate the termination resistor; leave the jumper pins open to bypass the termination resistor.

The onboard DIP switches, S1 and S2, are used to select RS-422 or RS-485 mode for each serial port. On each bank, switch 1 corresponds to port 1 and switch 2 corresponds to port 2. S2 selects between RS-422 and RS-485; S1 selects between 2-wire and 4-wire RS-485.

### CP-102UL

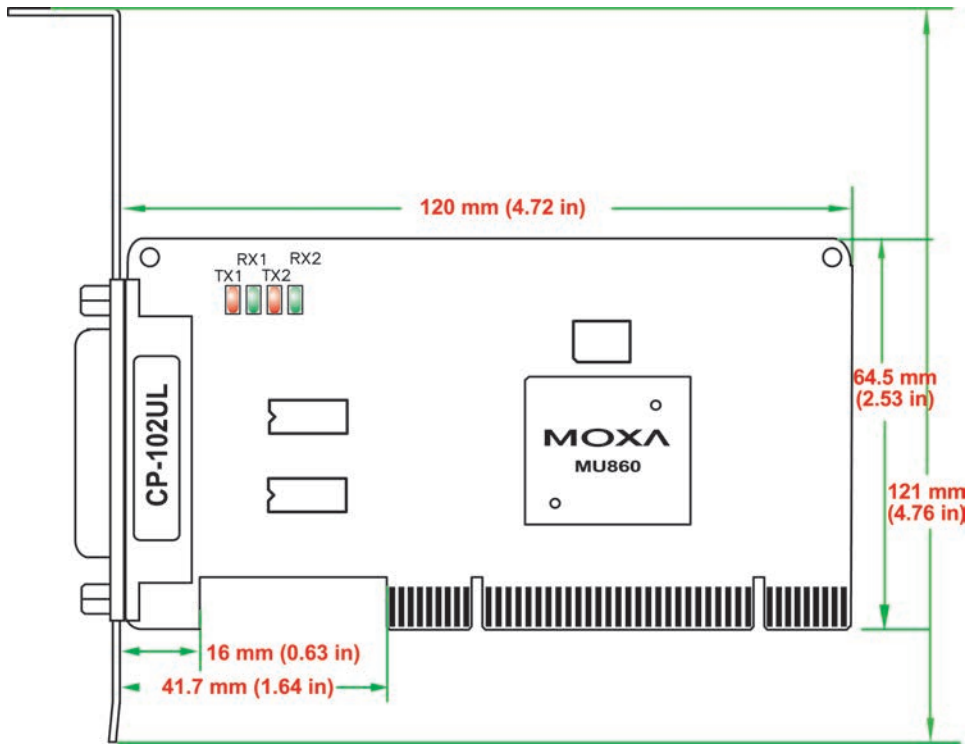

This board does not require configuration.

### CP-102U

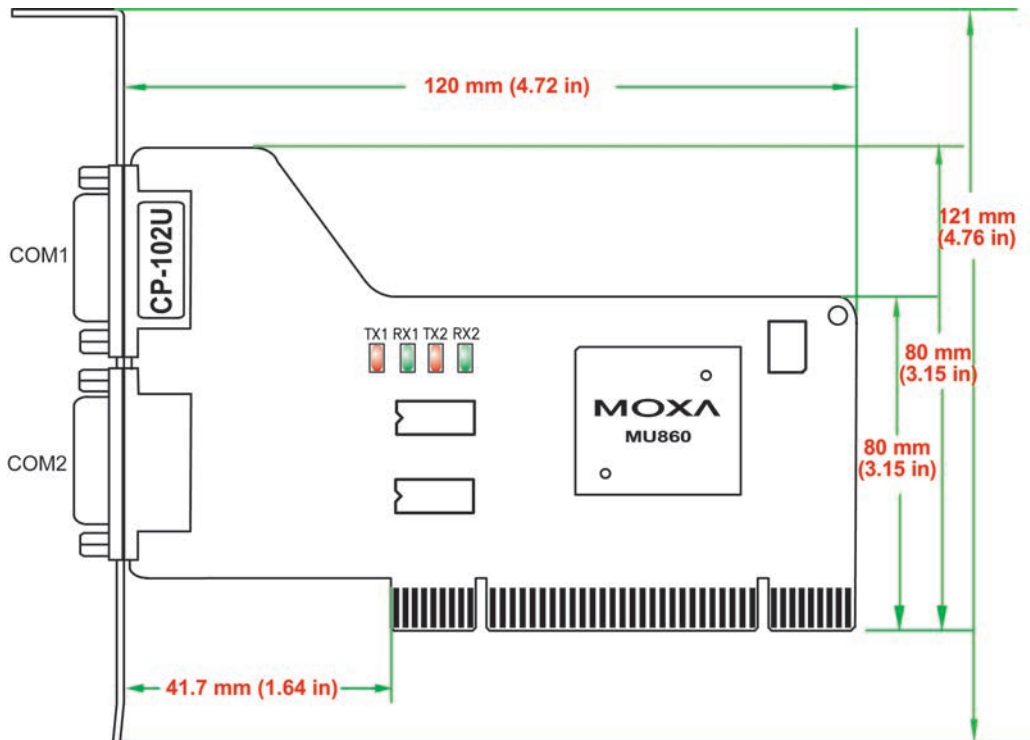

This board does not require configuration.



# CP-102UF

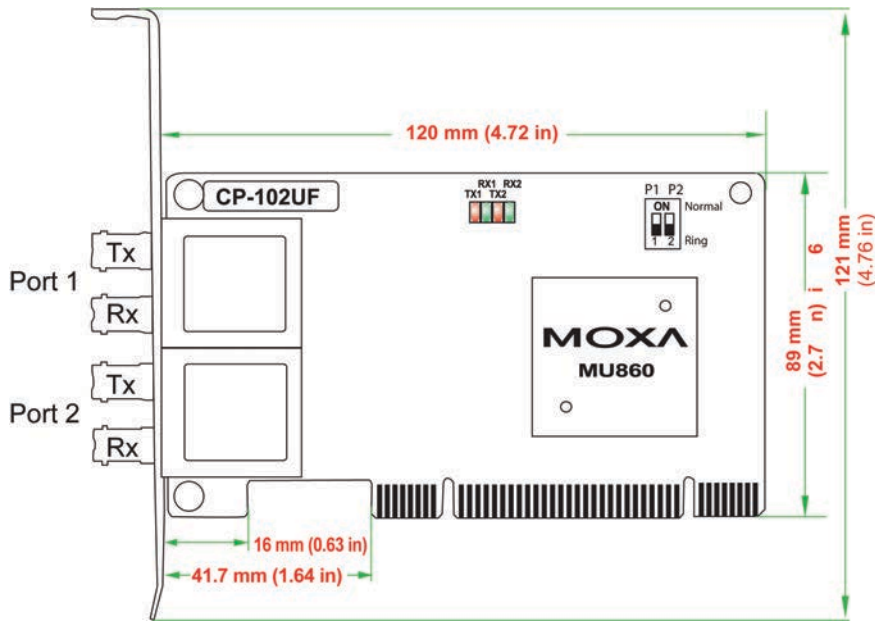

The onboard DIP switches are used to configure the CP-102UF for “Ring mode” or “Normal”. When using the CP-102UF board, your PC can be included as one node of a fiber ring formed using Moxa’s own TCF-142 serial-to-fiber converter. Since each TCF-142 has two fiber ports and one serial port, PCs that are part of the ring will be able to communicate with serial devices connected to the ring. Note that the Tx port of the CP-102UF connects to a neighboring converter’s Rx port to form the ring. When one node transmits a signal, the signal travels around the ring until it returns back to the transmitting unit, which then blocks the signals.

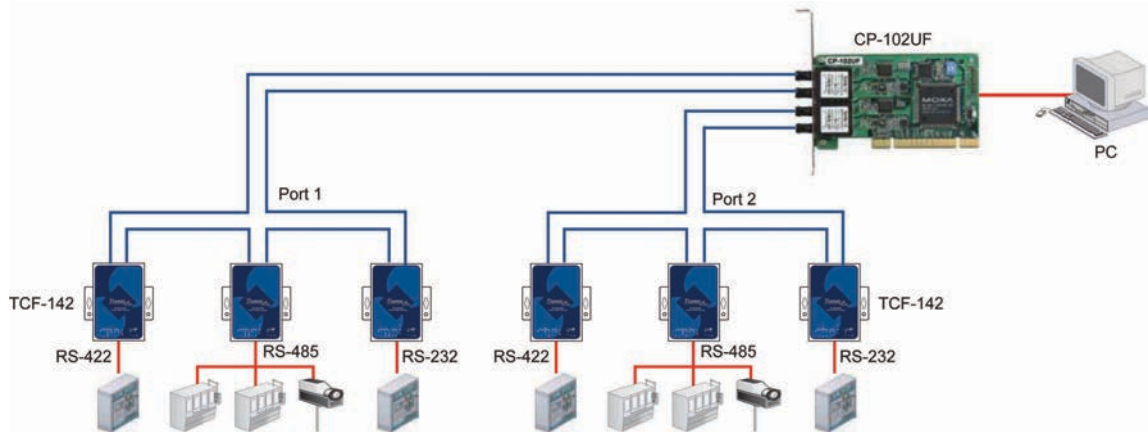

**NOTE** When configuring two or more CP-102UF boards installed in the same computer, please pay attention to the model names of the boards. The two models can be recognized by the type of connector on the board. Model CP-102UF-M uses plastic ST connectors, whereas model CP-102UF-S uses metal ST connectors.

# Plugging the Board into an Expansion Slot

**ATTENTION****Safety First!**

To avoid damaging your system and board, make sure your PC's power is turned off before installing your Universal PCI Board.

**Step 1:** Power off the PC.

**Step 2:** Shut off the power to any peripheral devices and remove the PC's cover.

**Step 3:** Configure the UPCI board's DIP switches and jumpers as necessary. This only applies to certain models. For additional information, please refer to your model in this chapter.

**Step 4:** Insert the board firmly into a free PCI or PCI-X slot on the PC.

**Step 6:** Use a screw to secure the board in place.

**Step 7:** Replace the PC's cover.

**Step 8:** Power on the PC. The BIOS will automatically set the IRQ and I/O address.

**Step 9:** Install the software. For details, please refer to the appropriate chapter for your operating system.

## **Driver Installation: Windows Vista/2008**

---

The following topics are covered in this chapter:

- Overview**
- Installing the Driver**
- Installing the Ports**
- Verifying the Installation**
- Configuring the Ports**
- Disabling the Board**
- Uninstalling the Board**

# Overview

This chapter explains how to install, configure, update, and remove the board drivers for Windows Vista. The following models are supported:

2 Ports	4 Ports	8 Ports
CP-112UL / CP-112UL-I	CP-114UL / CP-114UL-I	CP-118U / CP-118U-I
CP-132UL / CP-132UL-I	CP-134U / CP-134U-I	CP-138U / CP-138U-I
CP-102UL	CP-104UL	CP-168U
CP-102U	CP-104JU	
CP-102UF	POS-104UL	

Windows Vista supports up to 256 serial ports, from COM1 to COM256. Moxa developed pure 32 and 64-bit Windows device drivers in order to fully utilize the advanced multi-process and multi-thread features of Windows Vista. The drivers conform to the Win32 COMM API standard.

You can download the drivers from the Moxa website. For information on developing your own serial programming applications, please refer to Chapter 9.

Before installing the software, be sure to install the hardware first. For details on installing the hardware, please refer to Chapter 2.

The overall procedure for installing the drivers is shown on the right. A newly installed board will be automatically detected by the operating system.

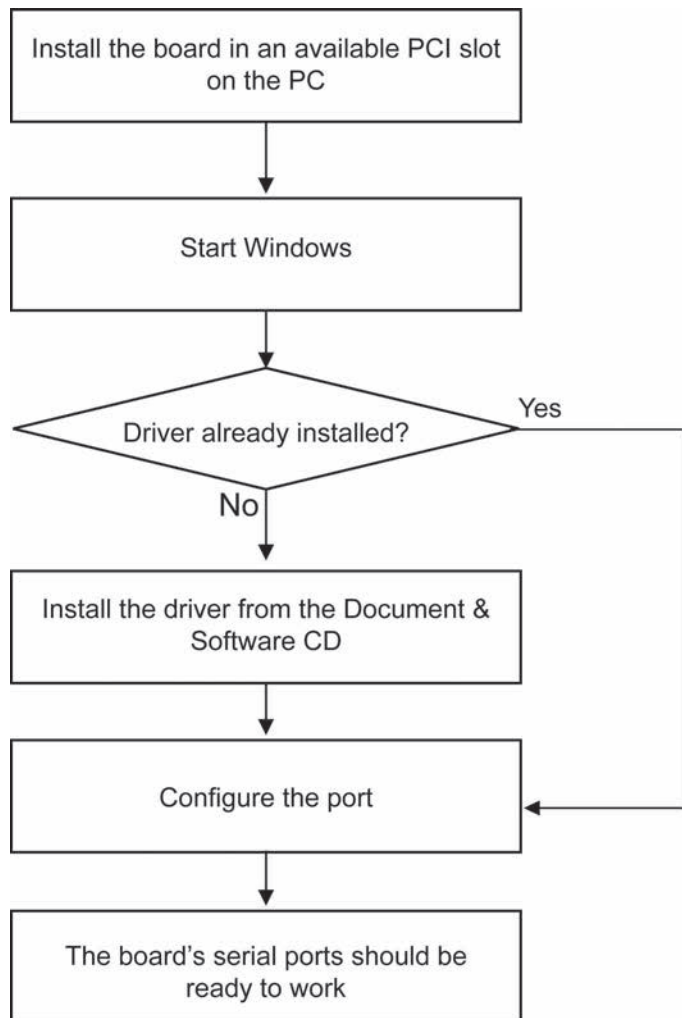

# Installing the Driver

The following instructions show how to install the driver for the first time under Windows Vista. You will need to plug the board in an available PCI or PCI-X slot first, before installing the driver. The installation procedure for Windows 2008 is similar.



## ATTENTION

The following steps will not be necessary if a Moxa UPCI board was already installed on your computer. Windows will automatically detect and install any additional board(s) at bootup. In this case, you may proceed directly to configuring the ports.

Note that these instructions use the CP-118U as an example. The procedure for installing all models is the same.

1. After the board is physically installed and the PC boots up, Windows will automatically detect the new board. The Found New Hardware Wizard window will open automatically. Select **Locate and install driver software (recommended)**.

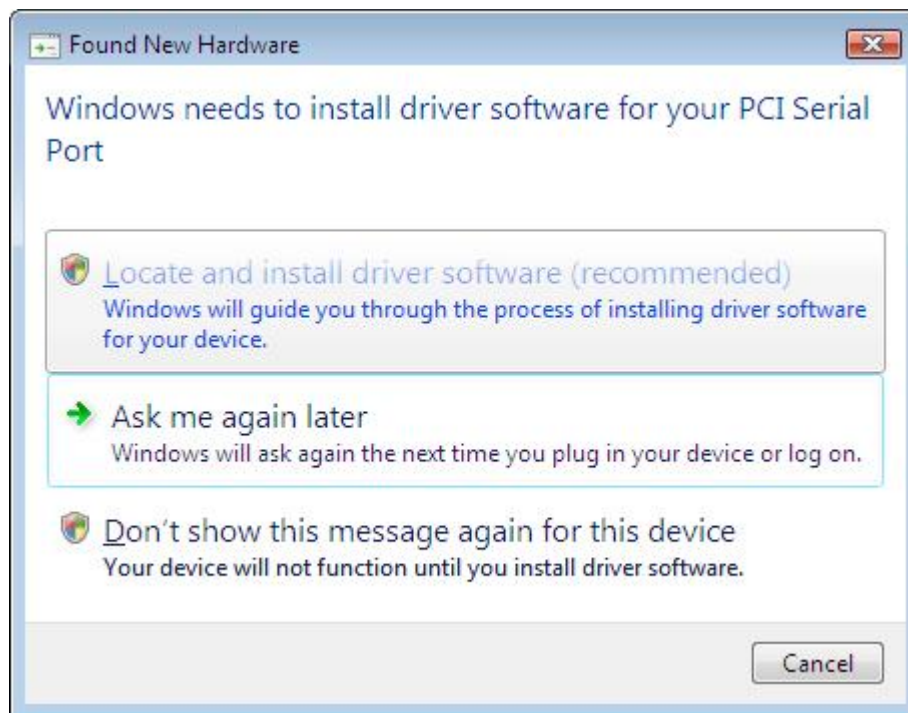

2. Select **I don't have the disc. Show me other options.**

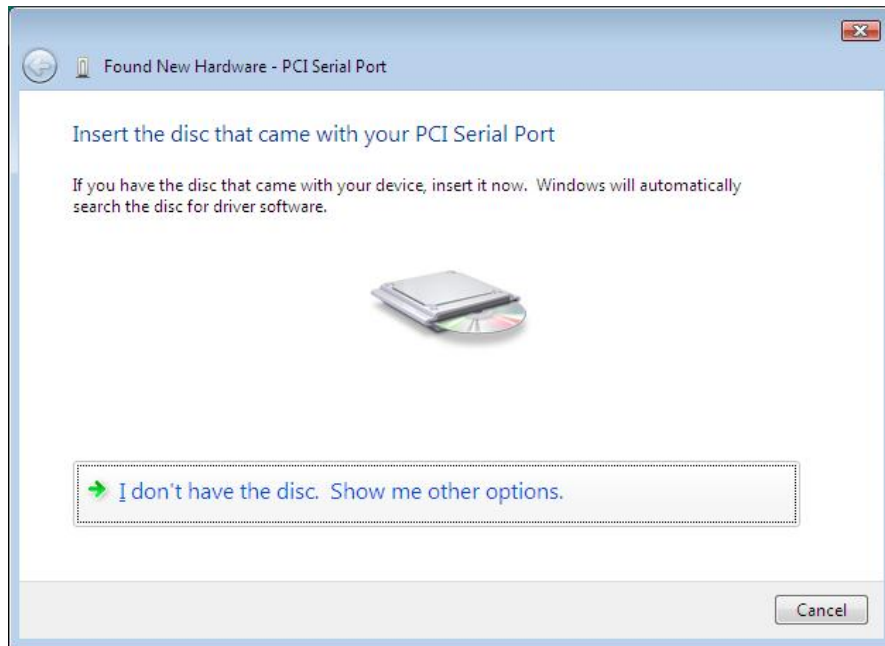

3. Select **Browse my computer for driver software (advanced).**

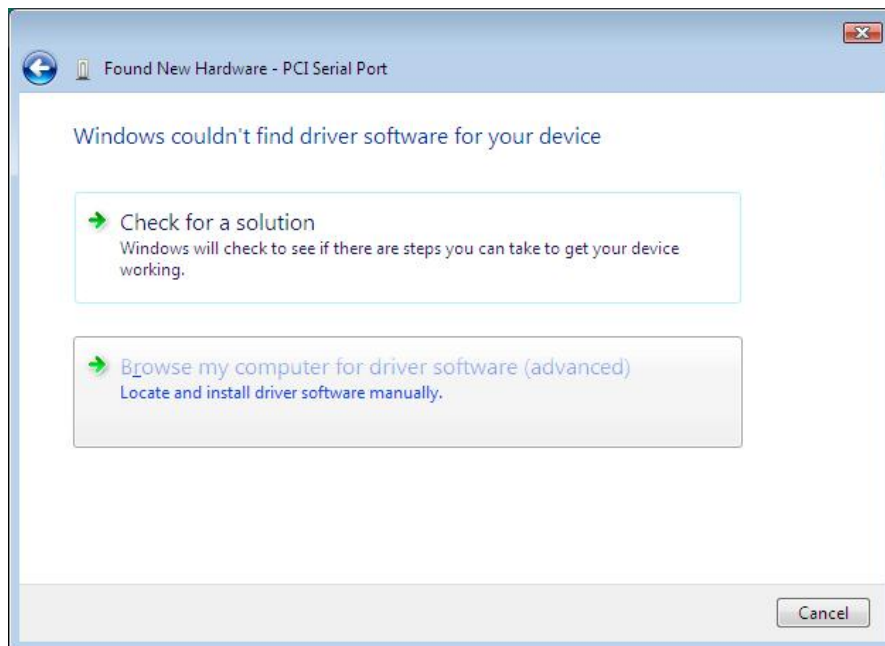

- Click **Browse** and select the appropriate directory on the Document & Software CD for the driver. Drivers for all operating systems are located under the product folder in the \Software directory (e.g., under \CP-118U Series\Software).

For 32-bit (x86) platforms, select the \Windows 2008\_Vista\x86 folder.

For 64-bit (x64) platforms, select the \Windows 2008\_Vista\x64 folder.

After selecting the folder, click **Next** to continue.

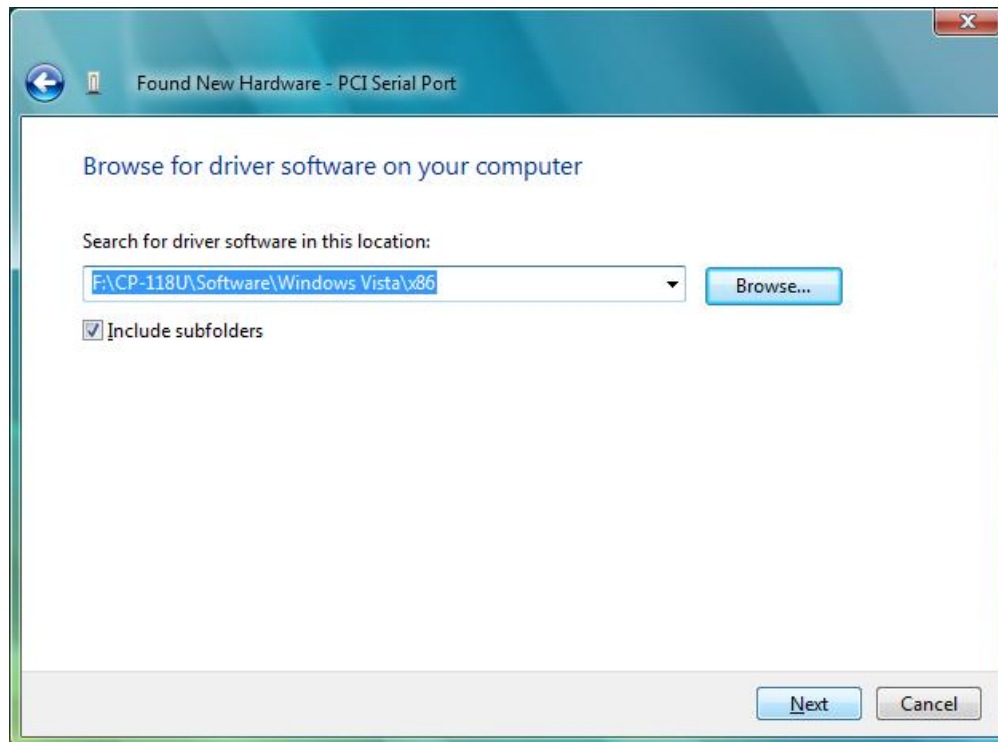

- If you receive a warning message stating that the Windows can't verify the publisher of the software, select **Install** this driver software anyway.

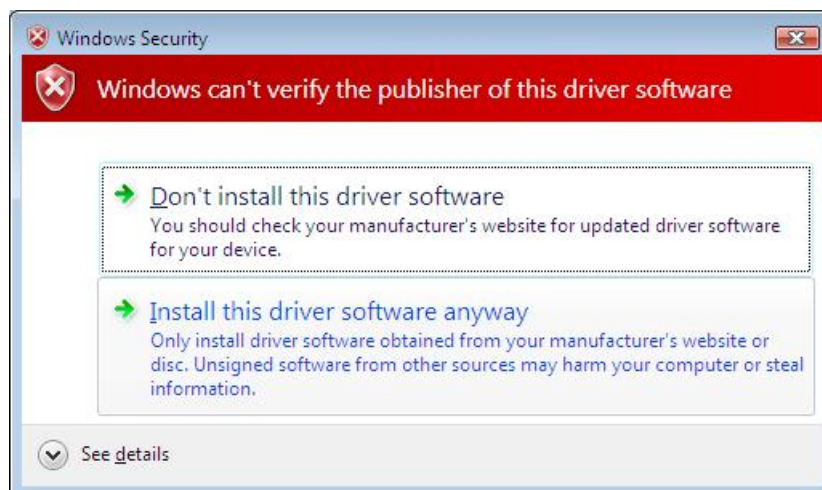

6. After the drivers have been installed, click **Close** to exit the wizard.

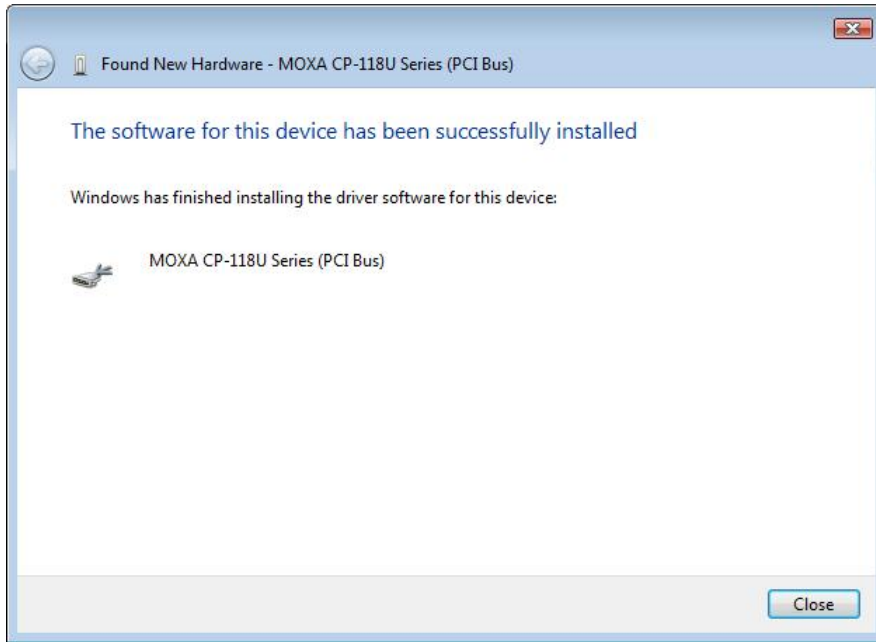

## Installing the Ports

After the board and drivers have been installed, an installation wizard will guide you through installation of the newly added serial ports, starting with port 0.

1. When prompted to insert a disc, select **I don't have the disc. Show me other options.**

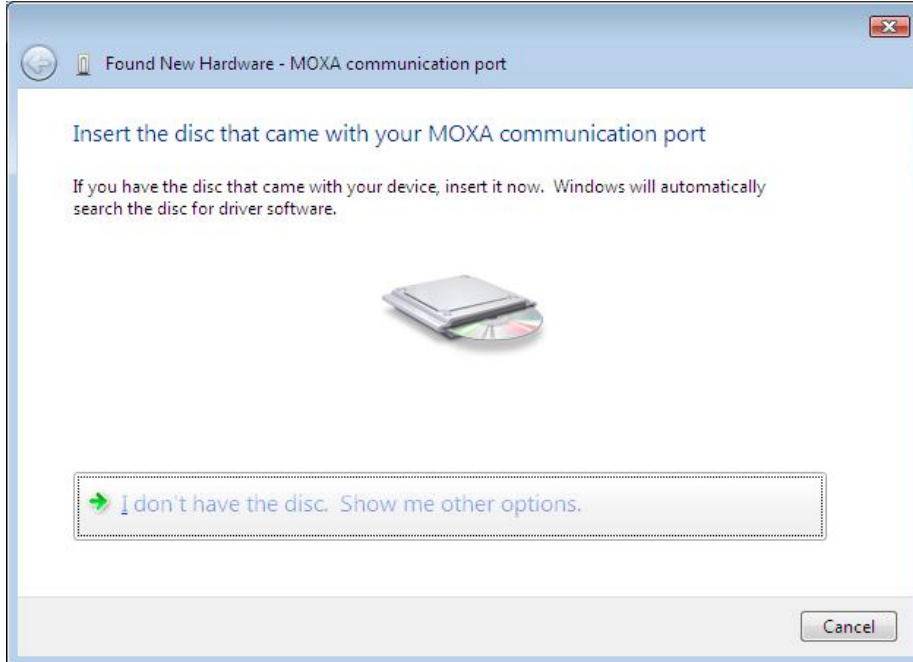



- 2. Select **Browse my computer for driver software (advanced)**.

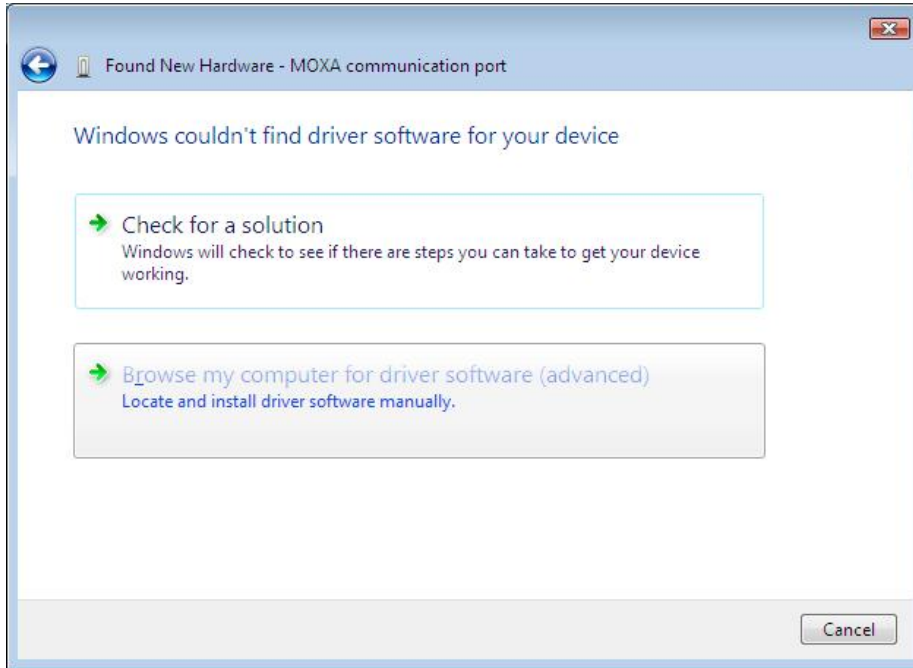

- 3. Click **Browse** and select the appropriate directory on the Document & Software CD for the driver. Drivers for all operating systems are located under the product folder in the \Software directory (e.g., under \CP-118U Series\Software). For 32-bit (x86) platforms, select the **\Windows 2008\_Vista\x86** folder. For 64-bit (x64) platforms, select the **\Windows 2008\_Vista\x64** folder. After selecting the folder, click **Next** to continue.

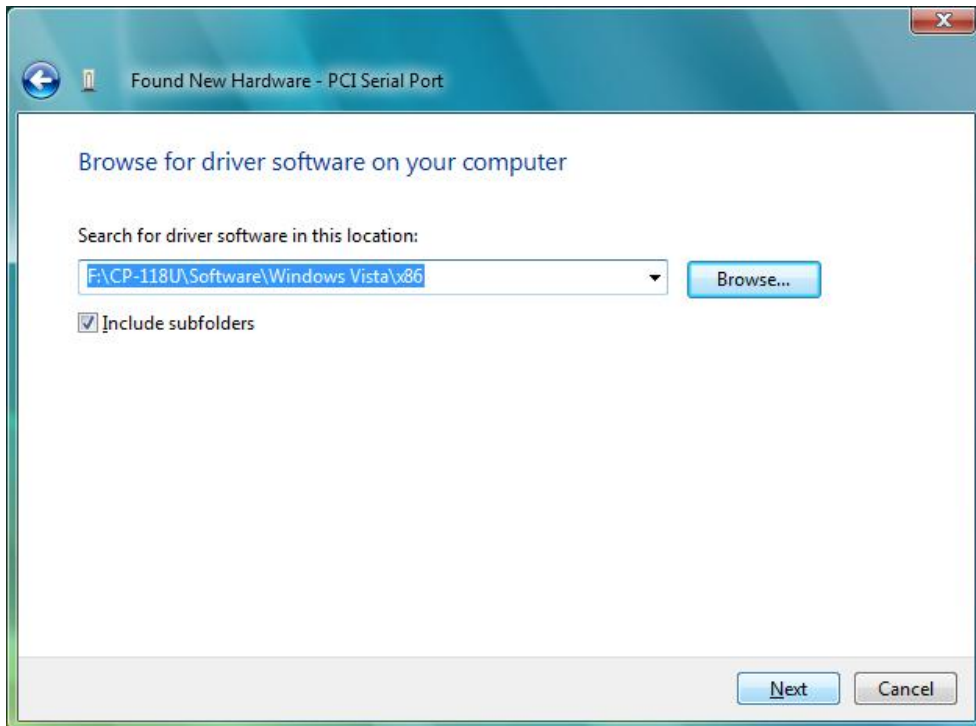

- If you receive a warning message stating that the Windows can't verify the publisher of the software, select **Install** this driver software anyway.

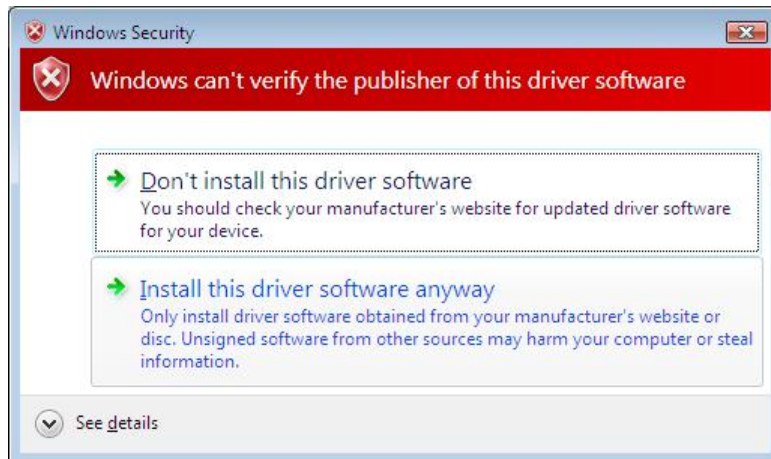

- After the drivers have been installed, click **Close to exit the wizard**. The other serial ports will automatically install in the background.

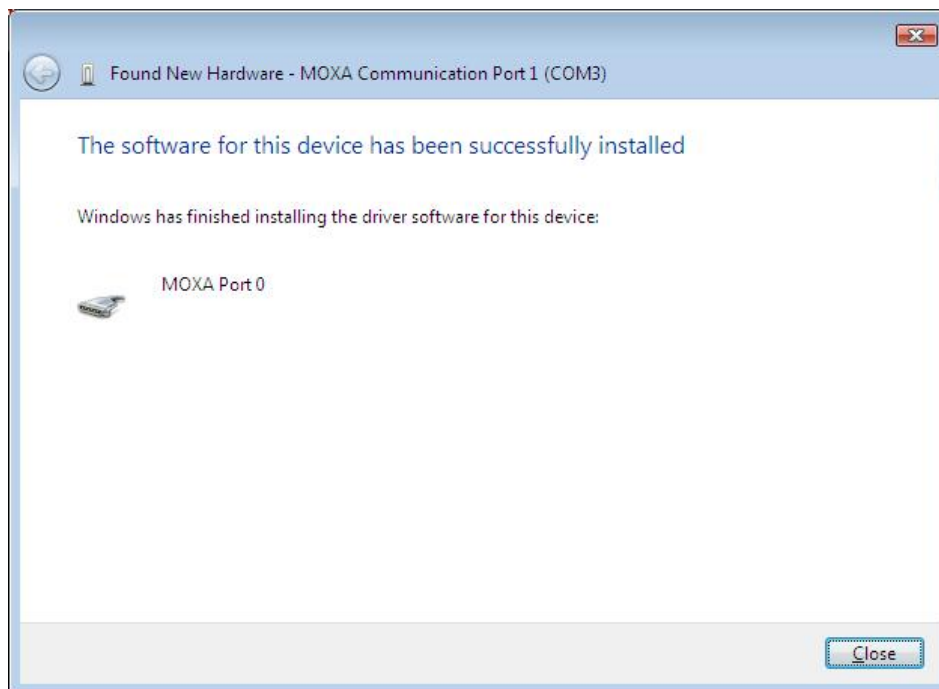

# Verifying the Installation

You can use Windows Device Manager to verify proper installation.

1. Under **My Computer**, click **System Properties**.

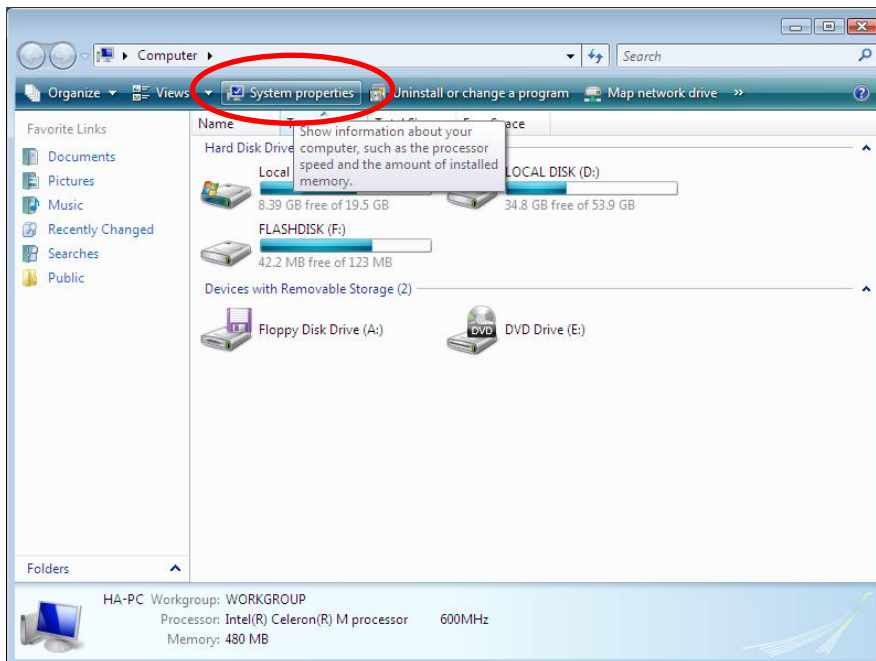

2. In the **System** window, click **Device Manager**.

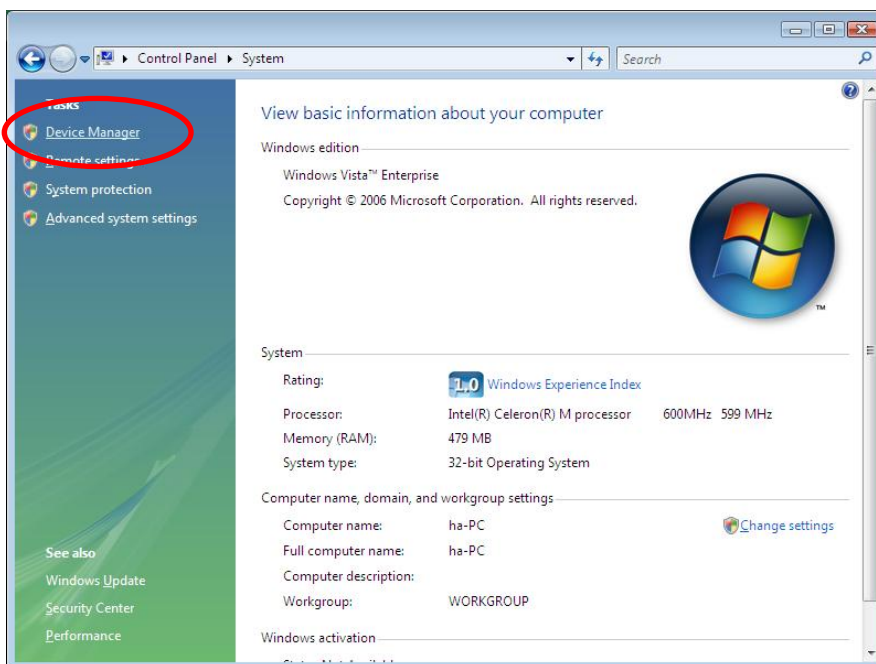

3. In the **Device Manager** window, you should see the UPCI board under **Multi-port serial adapters** (CP-118U in this example). You should also see Moxa communication ports under **Ports (COM & LPT)**.

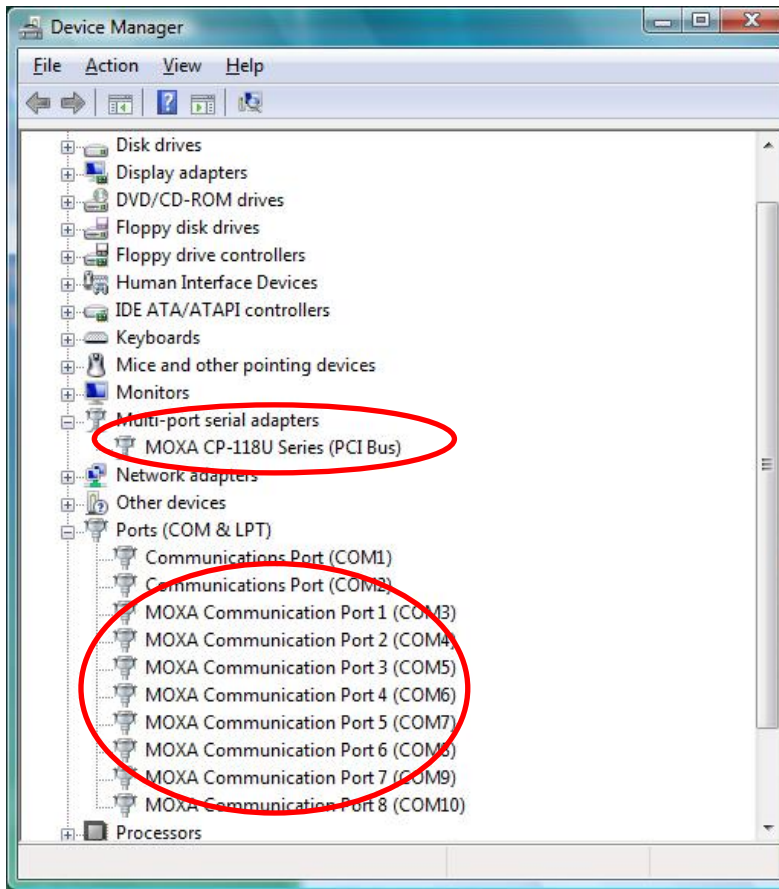

4. If you see any special marks, such as a question mark or an exclamation mark, next to the Moxa items, the installation of your module or serial ports was not successful. Examine the Windows event log for details.

# Configuring the Ports

After the board and serial port drivers are installed, the board's **Properties** window will appear. The system will map the ports automatically. You may be prompted to take care of port configuration if other Moxa boards have been installed.

1. On the **Ports Configuration** tab, select a port to configure and click **Port Setting**.

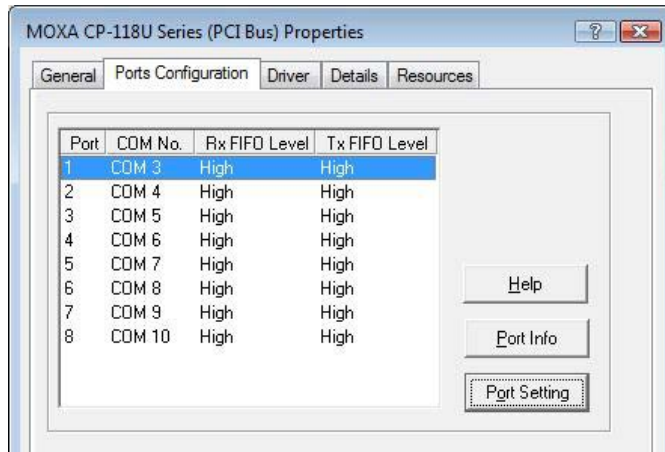

2. Under **Port Number**, select a COM number to assign to the serial port. Select **Auto Enumerating COM Number** to map subsequent ports in numerical order. For example, if COM 3 is assigned to Port 1, then COM 4 will be automatically assigned to Port 2.

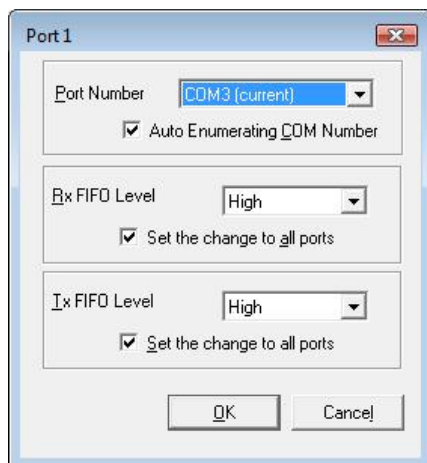

Select an **Rx FIFO Trigger** and **Tx FIFO Size**. The default Rx FIFO Trigger is 120 bytes (high level). The default Tx FIFO Size is 128 bytes (high level). Select **Set the change to all ports** to use this setting for all serial ports on the board.

	Tx FIFO	Rx FIFO
<b>High</b>	128	120
<b>Middle</b>	64	60
<b>Low</b>	1	1

3. Click **OK** to approve the settings for the selected port. Continue in the same way to configure the other ports. When you have finished setting up the ports, click **OK** to close the **Properties** window and apply the new port settings.

# Disabling the Board

1. Right-click **My Computer** and select **Properties** in the context menu.

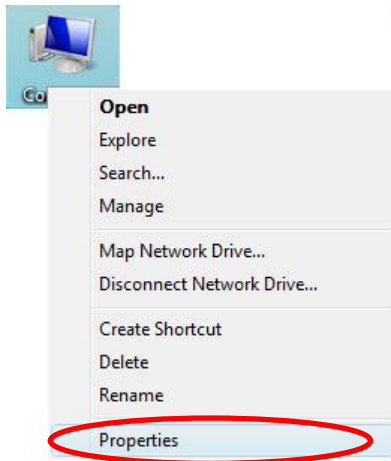

2. In the **System** window, click **Device Manager**.

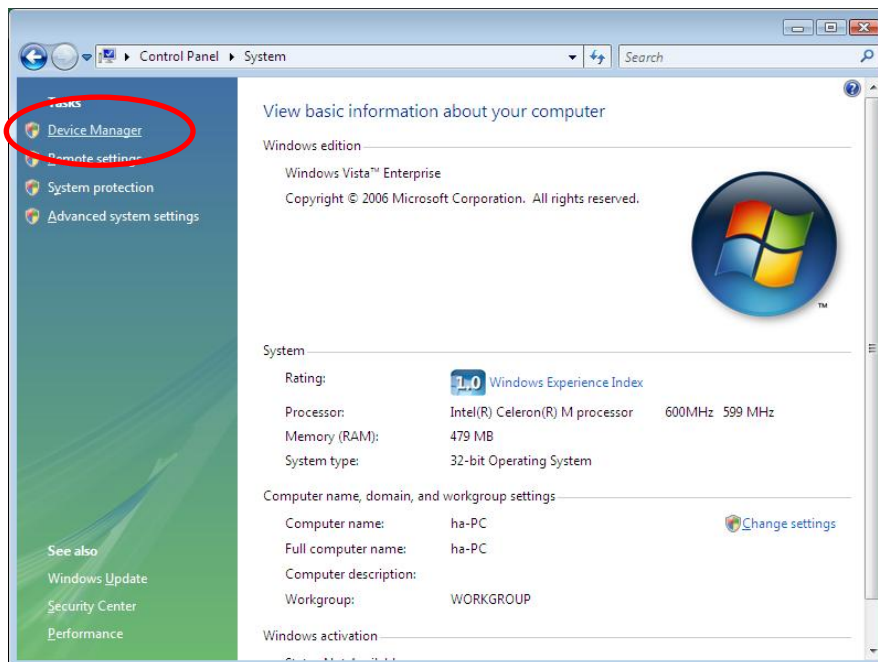

3. In **Device Manager**, right-click the UPCI board under **Multi-port serial adapters** and select **Disable** in the context menu. This will disable the board.

# Uninstalling the Board

1. Right-click **My Computer** and select **Properties** in the context menu.

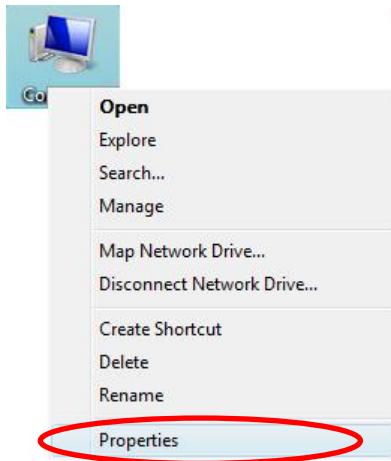

2. In the **System** window, click **Device Manager**.

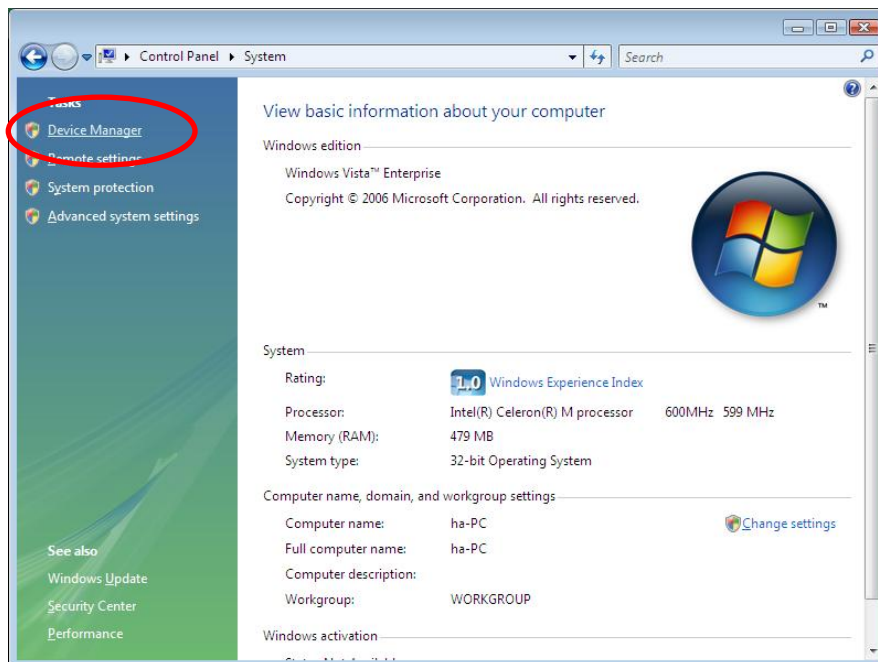

3. Right-click the UPCI board under **Multi-port serial adapters** (CP-118U in this example) and select **Uninstall** in the context menu.
4. A confirmation dialog will appear. Click **OK** to uninstall the device.

## Driver Installation: Windows XP/2003

---

The following topics are covered in this chapter:

- Overview
- Installing the Driver
- Installing the Ports
- Verifying the Installation
- Configuring the Ports
- Using PComm
- Using Event Log
- Disabling the Board
- Uninstalling the Board



# Overview

This chapter explains how to install, configure, update, and remove the board drivers for Windows XP/2003. The following models are supported:

2 Ports	4 Ports	8 Ports
CP-112UL/ CP-112UL-I	CP-114UL / CP-114UL-I	CP-118U / CP-118U-I
CP-132UL / CP-132UL-I	CP-134U / CP-134U-I	CP-138U / CP-138U-I
CP-102UL	CP-104UL	CP-168U
CP-102U	CP-104JU	
CP-102UF	POS-104UL	

Windows XP/2003 supports up to 256 serial ports, from COM1 to COM256. Moxa developed pure 32 and 64-bit Windows device drivers in order to fully utilize the advanced multi-process and multi-thread features of Windows XP/2003. The drivers conform to the Win32 COMM API standard.

You can download the drivers from the Moxa website. For information on developing your own serial programming applications, please refer to Chapter 9.

Before installing the software, be sure to install the hardware first. For details on installing the hardware, please refer to Chapter 2.

The overall procedure for installing the drivers is shown on the right. A newly installed board will be automatically detected by the operating system.

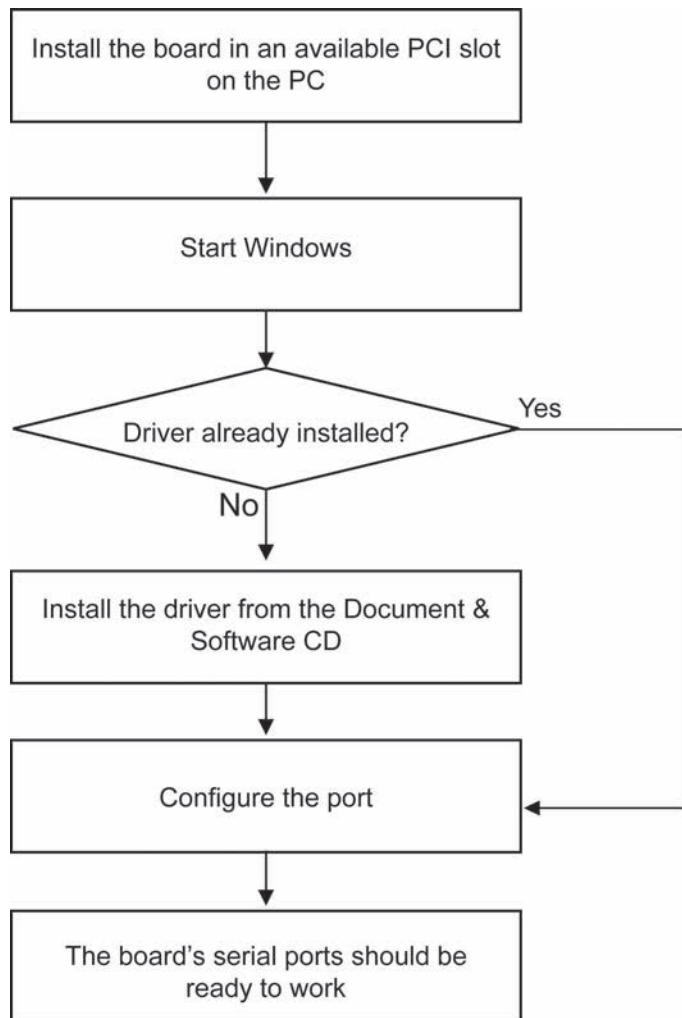

# Installing the Driver

The following instructions show how to install the driver for the first time under Windows XP. The same procedure is used for Windows 2003. You will need to plug the board in an available PCI or PCI-X slot first, before installing the driver.



## ATTENTION

The following steps will not be necessary if a Moxa UPCI board was already installed on your computer. Windows will automatically detect and install any additional board(s) at bootup. In this case, you may proceed directly to configuring the ports.

Note that these instructions use the CP-118U as an example. The procedure for installing all models is the same.

1. After the board is physically installed and the PC boots up, Windows will automatically detect the new board. The Found New Hardware Wizard window will open automatically. When prompted to connect to Windows Update, select **No, not this time** and click **Next** to continue.



2. Select **Install from a list or specific location (Advanced)** and click **Next** to continue.

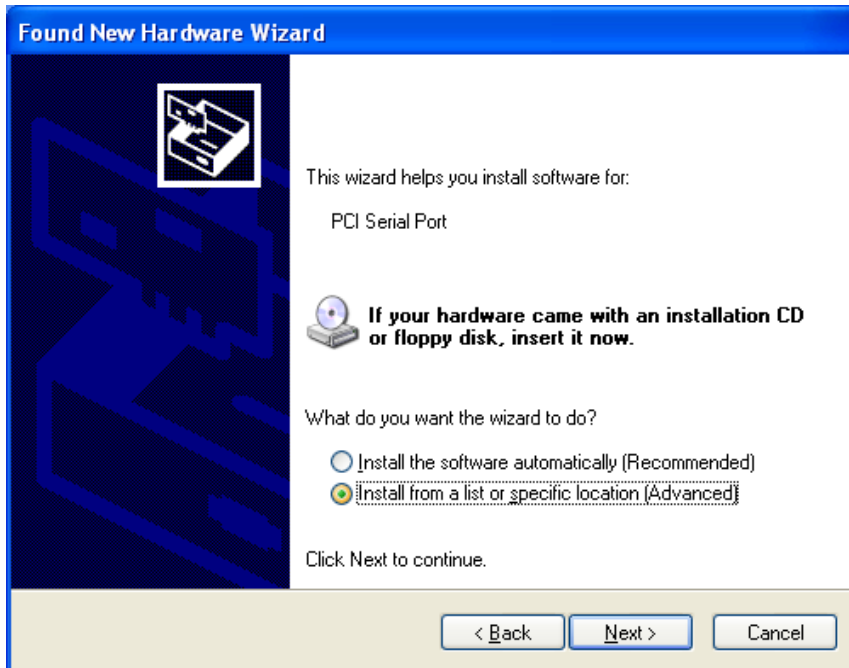

3. Select **Search for the best driver in these locations** and **Include this location in the search**. Click **Browse** and select the appropriate directory on the Document & Software CD for the driver. Drivers for all operating systems are located under the product folder in the \Software directory (e.g., under \CP-118U Series\Software). For 32-bit (x86) platforms, select the **\Windows XP\_2003\x86** folder. For 64-bit (x64) platforms, select the **\Windows XP\_2003\x64** folder. After selecting the folder, click **Next** to continue.

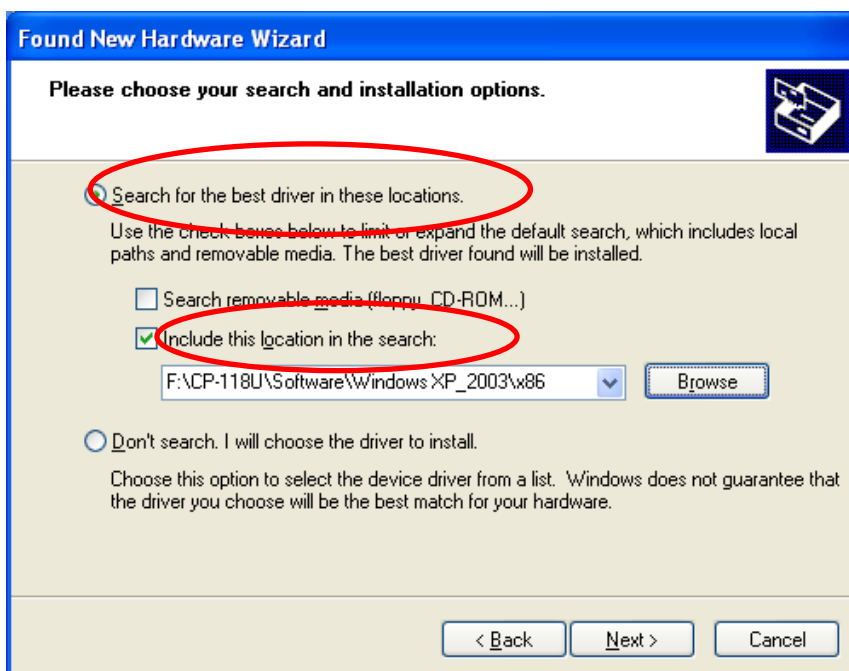

4. If you see a warning that the software has not passed Windows Logo testing, click **Continue Anyway**.



5. Windows will install the drivers. When the installation is complete, click **Finish**.

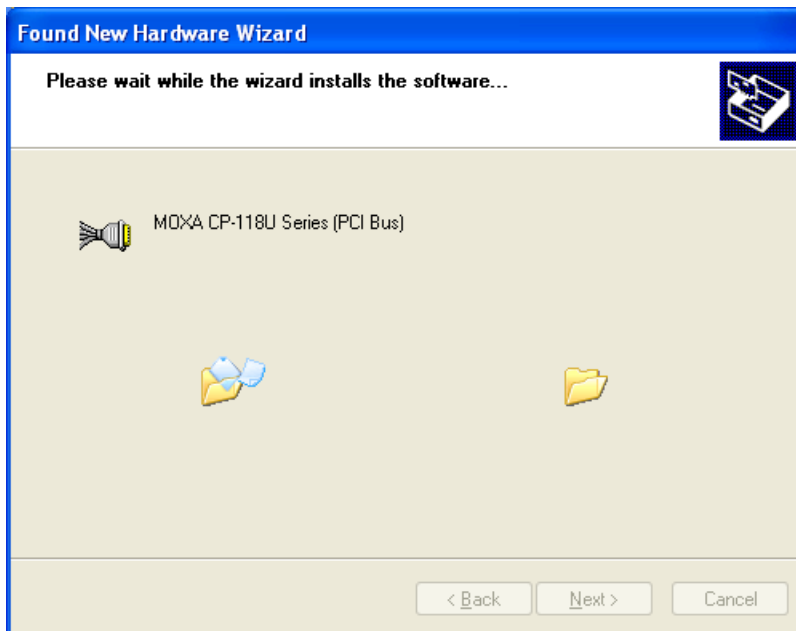

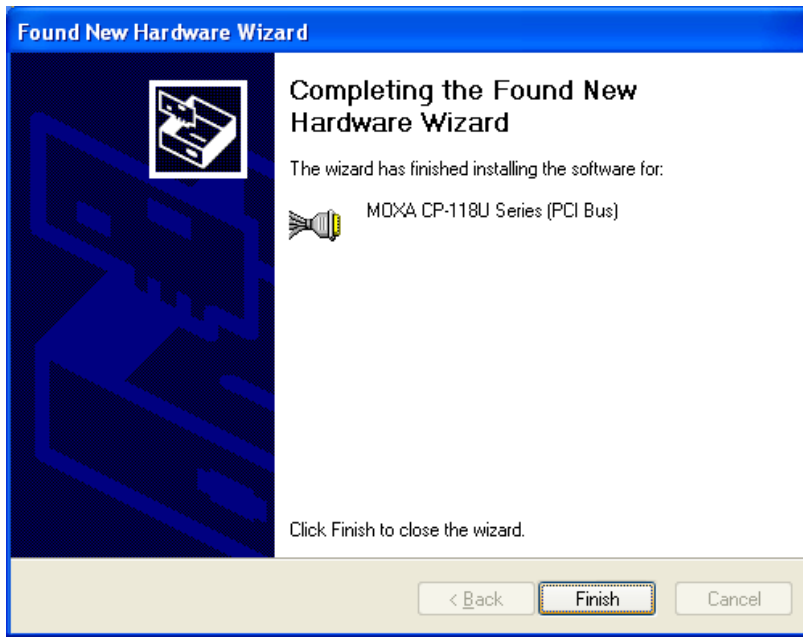

## Installing the Ports

After the board and drivers have been installed, an installation wizard will guide you through installation of the newly added serial ports, starting with port 0.

1. When prompted to connect to Windows Update, select **No, not this time** and click **Next** to continue.



2. Select **Install from a list or specific location (Advanced)** and click **Next** to continue.

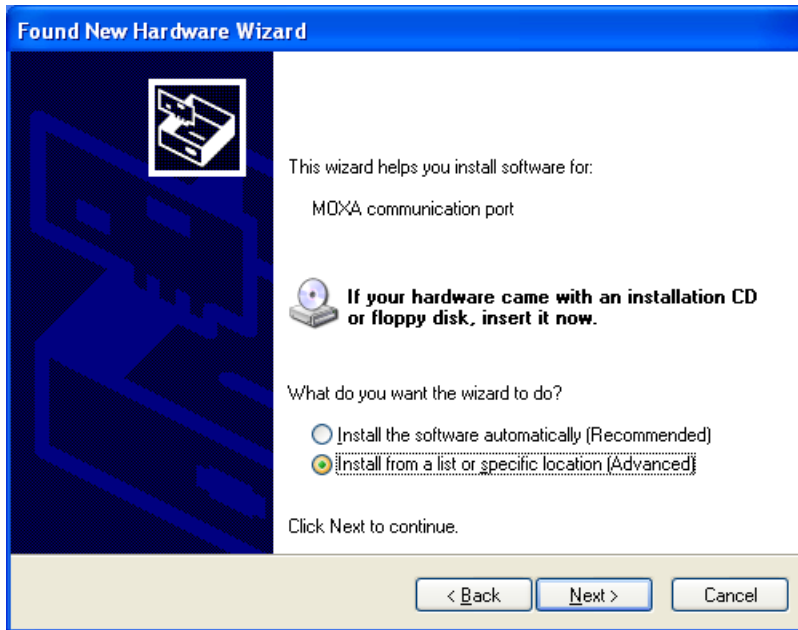

3. Select **Search for the best driver in these locations** and **Include this location in the search**. Click **Browse** and select the appropriate directory on the Document & Software CD for the driver. Drivers for all operating systems are located under the product folder in the \Software directory (e.g., under \CP-118U Series\Software).

For 32-bit (x86) platforms, select the **\Windows XP\_2003\x86** folder.

For 64-bit (x64) platforms, select the **\Windows XP\_2003\x64** folder.

After selecting the folder, click **Next** to continue.

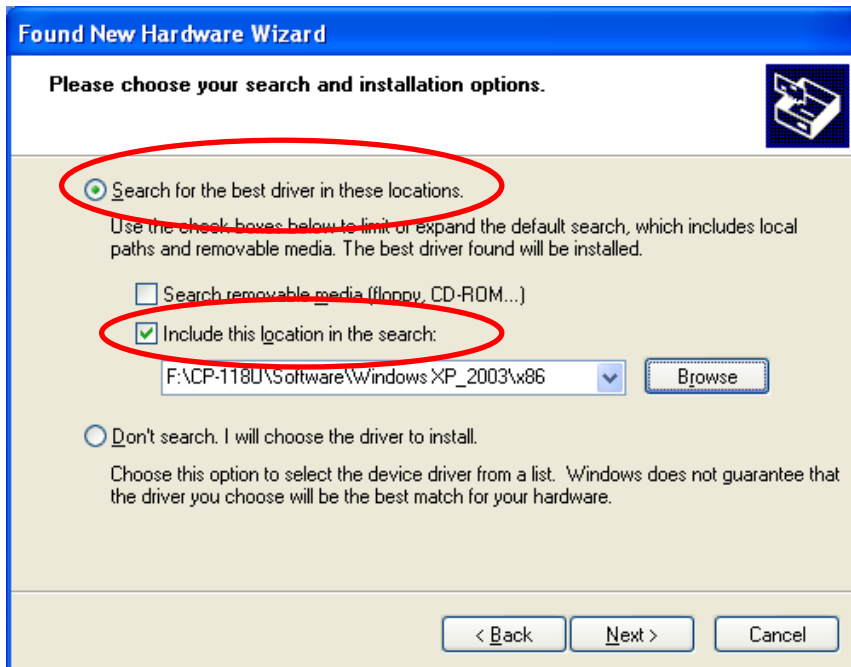

- 4. If you see a warning that the software has not passed Windows Logo testing, click **Continue Anyway**.



- 5. After the drivers for the serial port have been installed, click **Finish** to close the wizard. Repeat this process for the remaining serial ports.

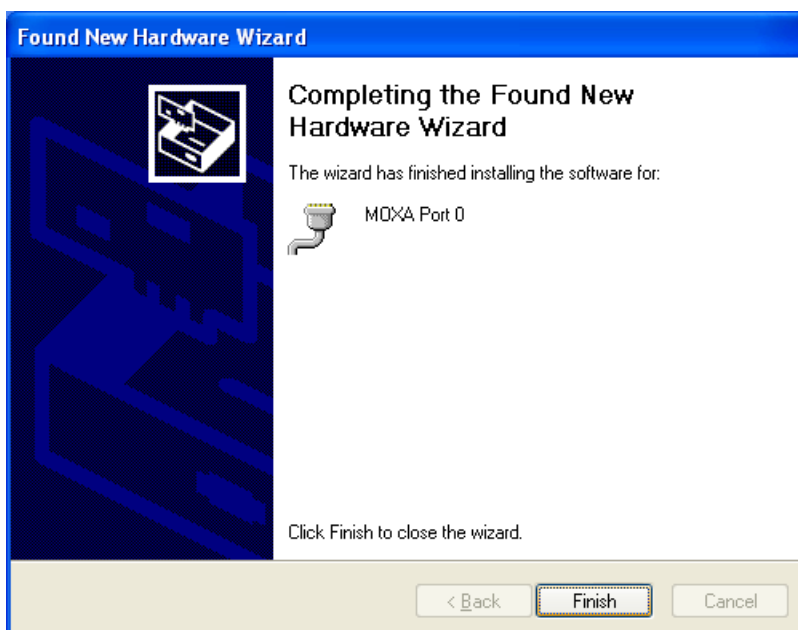
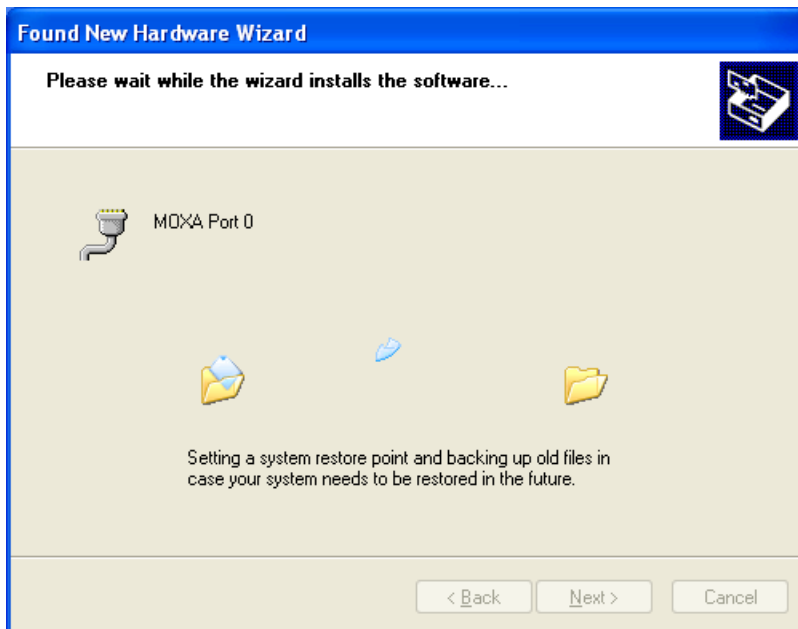

# Verifying the Installation

You can use Windows Device Manager to verify proper installation of the board.

1. Right-click **My Computer** and select **Properties** in the context menu.

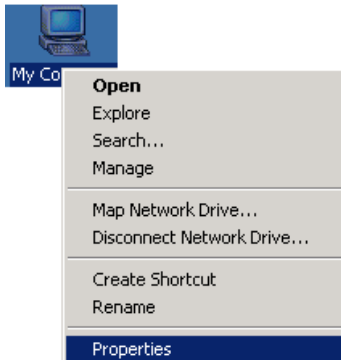

2. In the **Hardware** tab, click **Device Manager**.

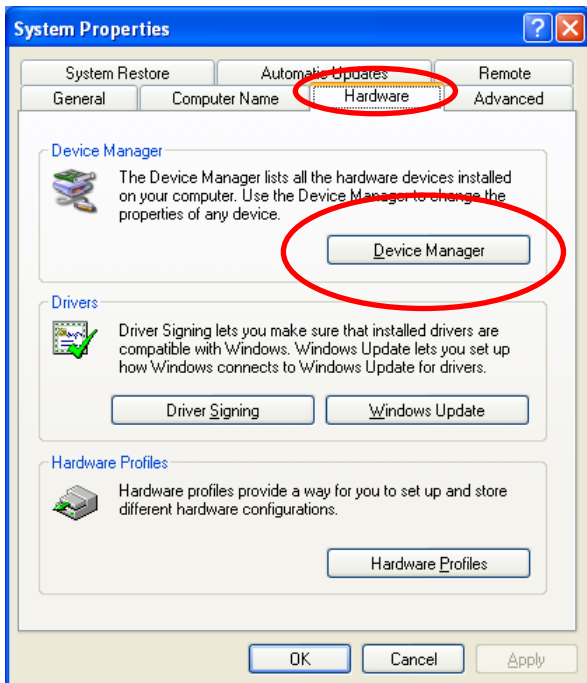



3. In the **Device Manager** window, you should see your UPCI board under **Multi-port serial adapters** (CP-118U in this example). You should also see Moxa communication ports under **Ports (COM & LPT)**.

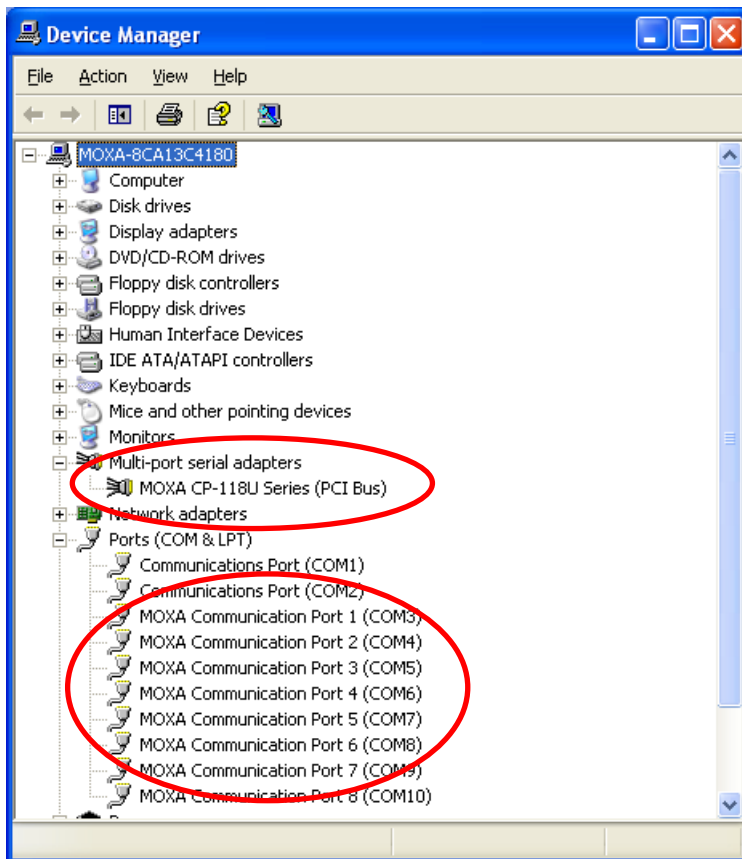

4. If you see any special marks, such as a question mark or an exclamation mark, next to the Moxa items, the installation of the board was not successful. Examine the Windows event log for details.

# Configuring the Ports

After the board and serial port drivers are installed, the board's **Properties** window will appear. The system will map the ports automatically. You may be prompted to take care of port configuration if other Moxa boards have been installed.

1. On the **Ports Configuration** tab, select a port to configure and click **Port Setting**.

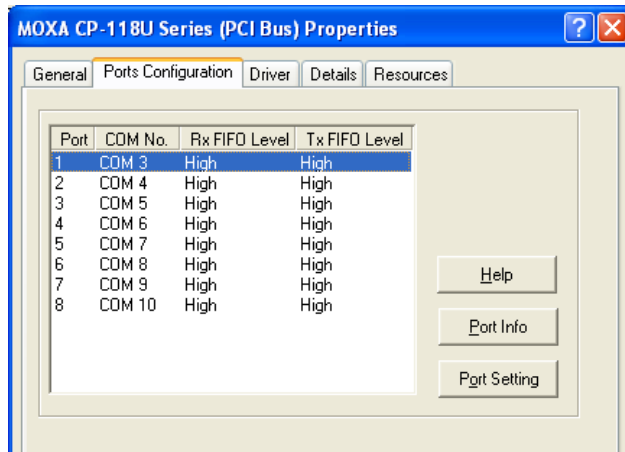

2. Under **Port Number**, select a COM number to assign to the serial port. Select **Auto Enumerating COM Number** to map subsequent ports in numerical order. For example, if COM 3 is assigned to Port 1, then COM 4 will be automatically assigned to Port 2.

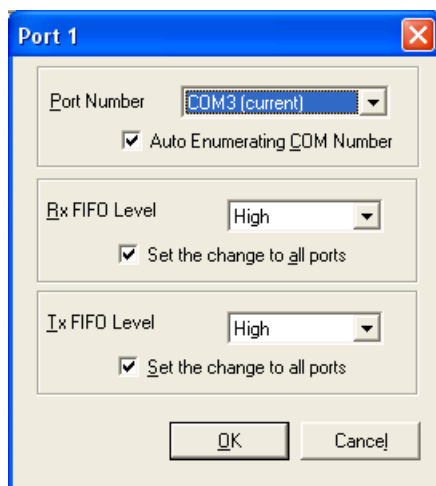

3. Select an **Rx FIFO Trigger** and **Tx FIFO Size**. The default Rx FIFO Trigger is 120 bytes (high level). The default Tx FIFO Size is 128 bytes (high level). Select **Set the change to all ports** to use this setting for all serial ports on the board.

	Tx FIFO	Rx FIFO
<b>High</b>	128	120
<b>Middle</b>	64	60
<b>Low</b>	1	1

4. Click **OK** to approve the settings for the selected port. Continue in the same way to configure the other ports. When you have finished setting up the ports, click **OK** to close the **Properties** window and apply the new port settings.

## Using PComm

PComm Diagnostic is a useful program for checking the board's status. It provides internal and external testing of IRQ, TxD/RxD, UART, CTS/RTS, DTR/DSR, and other items. You can use PComm Diagnostic to verify that the module and serial ports are working properly.

You may download PComm from the Moxa website.

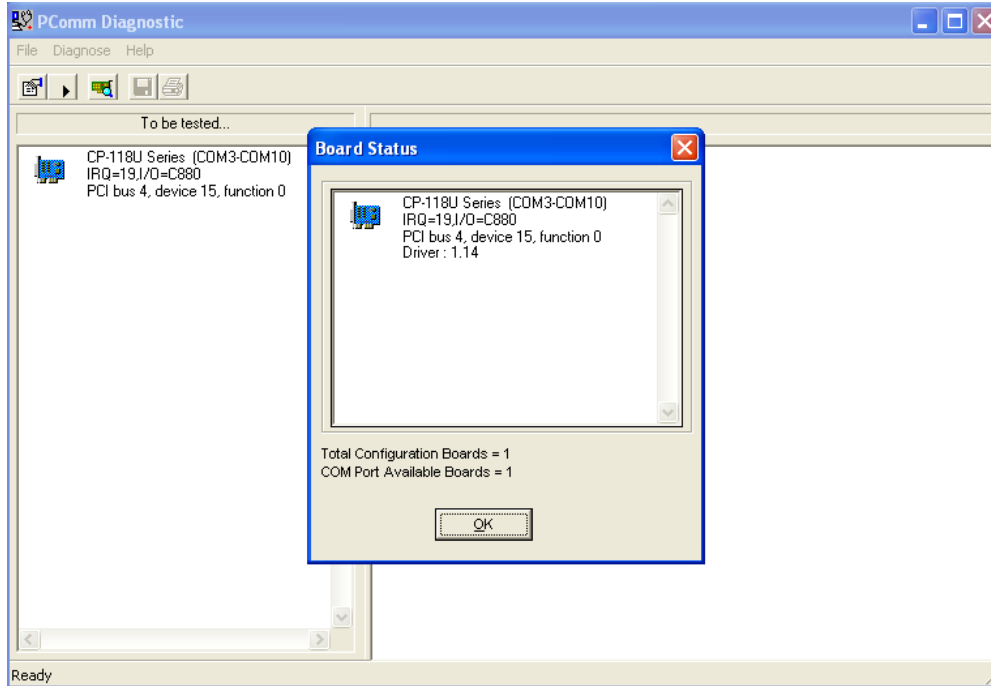

## Using Event Log

You may refer to the Windows event log to verify operation of the board. To view the event log, open Event Viewer, which is located under Administrative Tools in the Control Panel. Information about the board will be located under the System category.

# Disabling the Board

1. Right-click **My Computer** and select **Properties** in the context menu.

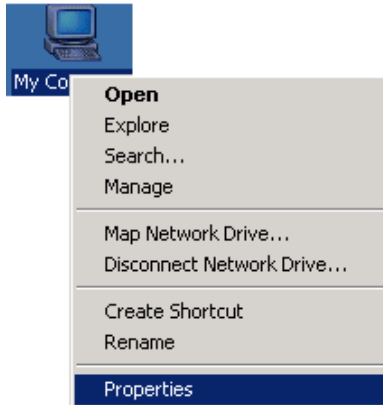

2. In the **Hardware** tab, click **Device Manager**.

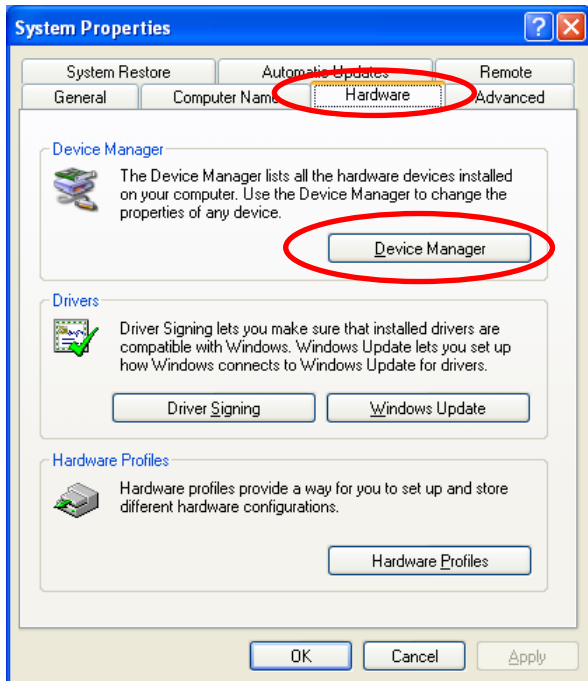

3. In **Device Manager**, right-click the UPCI board under **Multi-port serial adapters** and select **Disable** in the context menu. This will disable the board.

# Uninstalling the Board

1. Right-click **My Computer** and select **Properties** in the context menu.

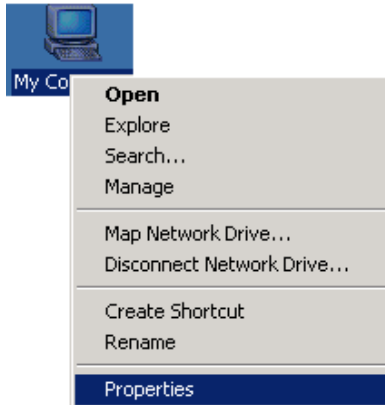

2. In the **Hardware** tab, click **Device Manager**.

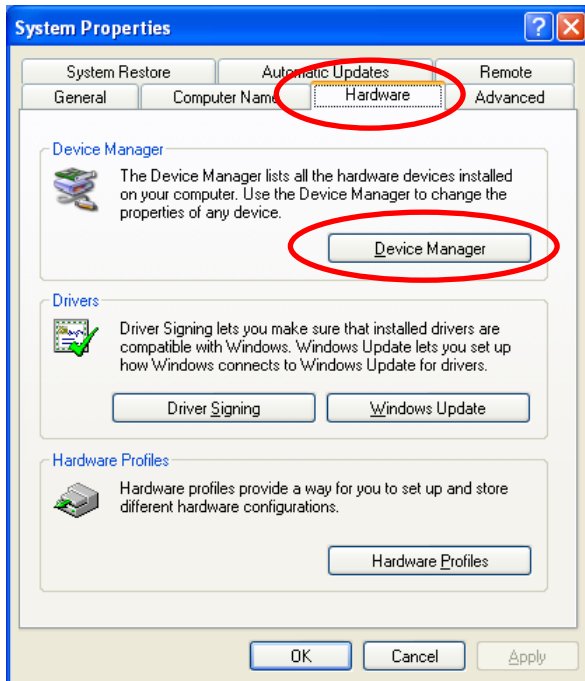

3. Right-click the UPCI board under **Multi-port serial adapters** (CP-118U in this example) and select **Uninstall** in the context menu.

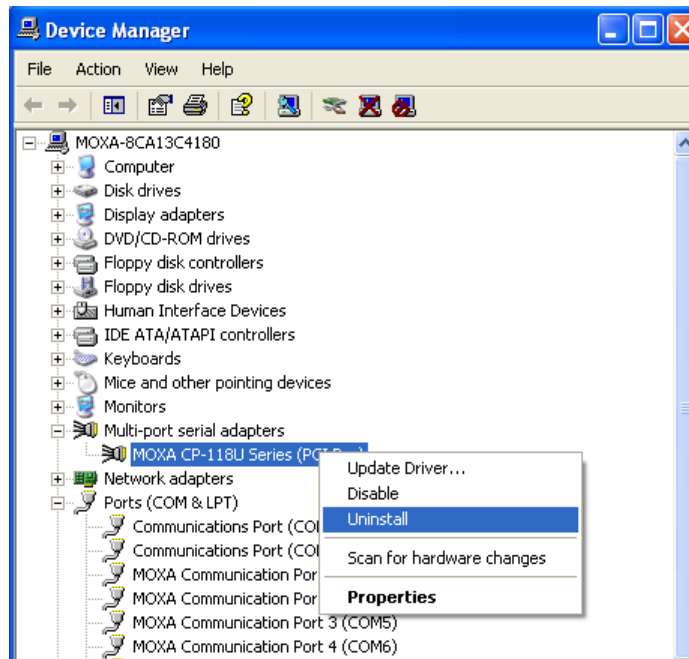

4. A confirmation dialog will appear. Click **OK** to uninstall the device.

## Driver Installation: Windows 2000

---

The following topics are covered in this chapter:

- **Overview**
- **Installing the Driver**
- **Installing the Ports**
- **Verifying the Installation**
- **Configuring the Ports**
- **Using PComm**
- **Using Event Log**
- **Disabling the Board**
- **Uninstalling the Board**

# Overview

This chapter explains how to install, configure, update, and remove the board drivers for Windows 2000. The following models are supported:

2 Ports	4 Ports	8 Ports
CP-112UL / CP-112UL-I	CP-114UL / CP-114UL-I	CP-118U / CP-118U-I
CP-132UL / CP-132UL-I	CP-134U / CP-134U-I	CP-138U / CP-138U-I
CP-102UL	CP-104UL	CP-168U
CP-102U	CP-104JU	
CP-102UF	POS-104UL	

Windows 2000 supports up to 256 serial ports, from COM1 to COM256. Moxa developed pure 32-bit Windows device drivers in order to fully utilize the advanced multi-process and multi-thread features of Windows 2000. The drivers conform to the Win32 COMM API standard.

You can download the drivers from the Moxa website. For information on developing your own serial programming applications, please refer to Chapter 9.

Before installing the software, be sure to install the hardware first. For details on installing the hardware, please refer to Chapter 2.

The overall procedure for installing the drivers is shown on the right. A newly installed board will be automatically detected by the operating system.

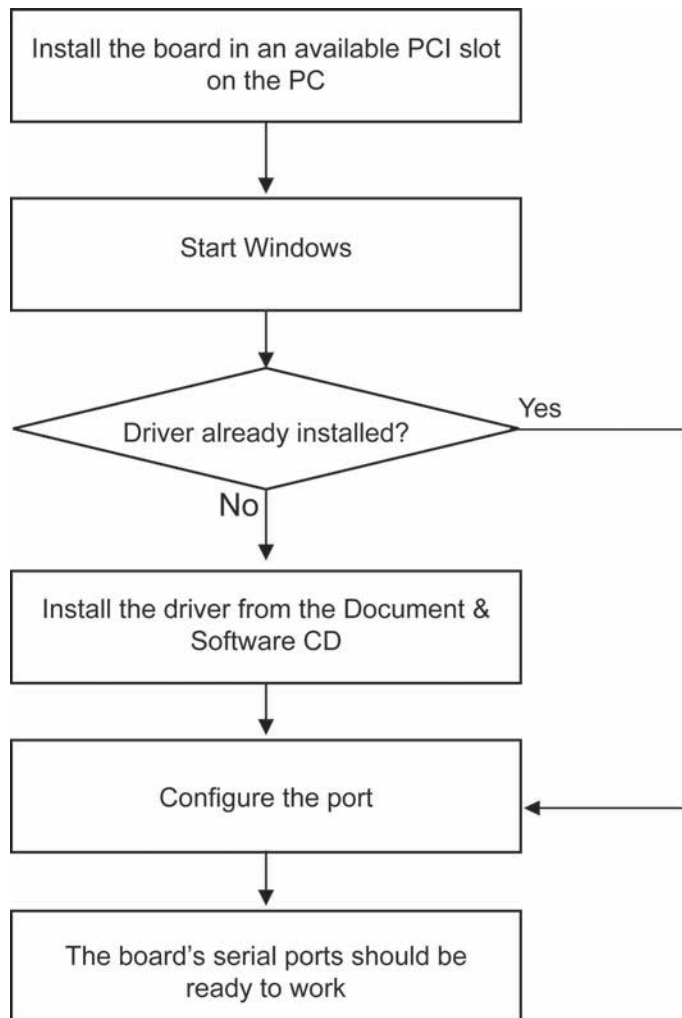



# Installing the Driver

The following instructions show how to install the driver for the first time under Windows 2000. You will need to plug the board in an available PCI or PCI-X slot first, before installing the driver.



## ATTENTION

The following steps will not be necessary if a Moxa UPCI board was already installed on your computer. Windows will automatically detect and install any additional board(s) at bootup. In this case, you may proceed directly to configuring the ports.

Note that these instructions use the CP-118U as an example. The procedure for installing all models is the same.

1. After the board is physically installed and the PC boots up, Windows will automatically detect the new board and the Found New Hardware Wizard window will open automatically. Click **Next** to continue.

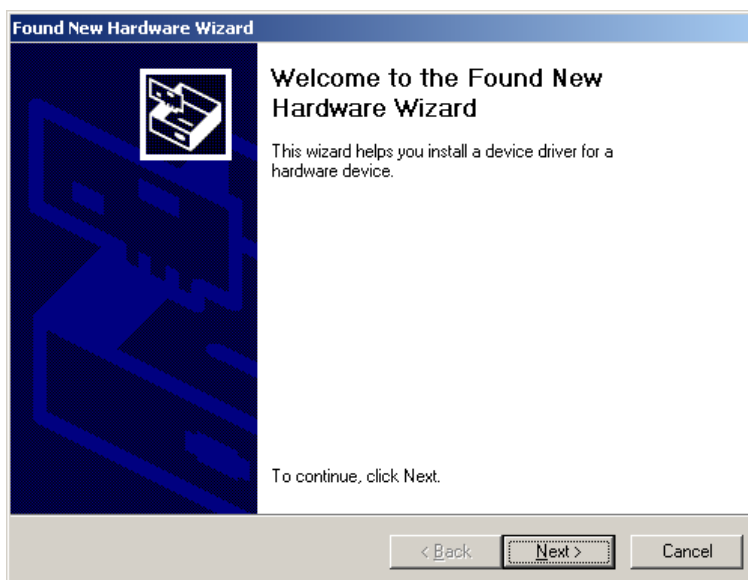
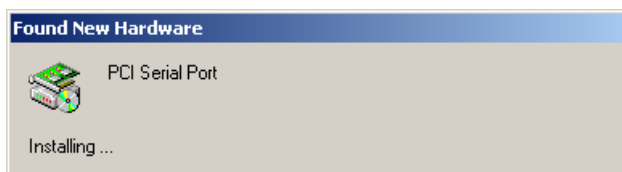

2. Select **Search for a suitable driver for my device (recommended)** and click **Next** to continue.



3. Select **Specify a location** and click **Next** to continue.

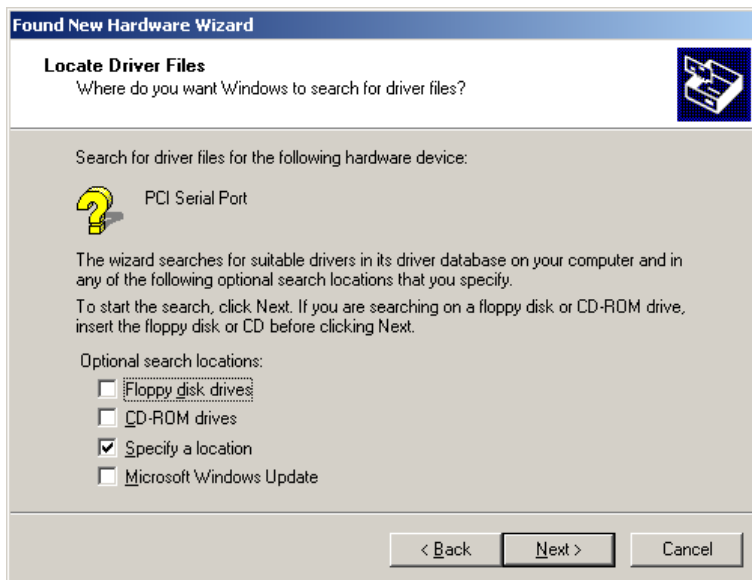

4. Click **Browse** and select the appropriate directory on the Document & Software CD for the driver. Drivers for all operating systems are located under the product folder in the **\Software** directory (e.g., under **\CP-118U Series\Software**). Select the **\Windows 2K** folder and click **Next** to continue.

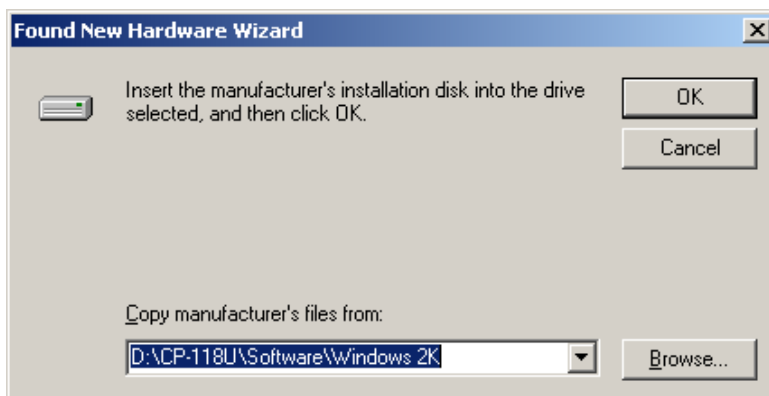

- 5. After the wizard has located the driver files, click **Next** to proceed.

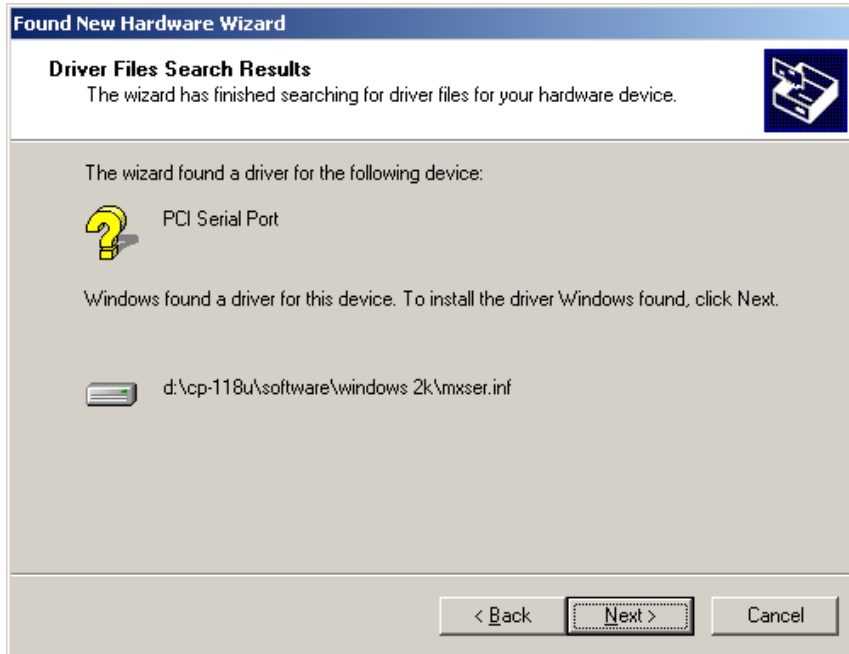

- 6. If you see a warning that the digital signature has not been found, click **Yes** to proceed.

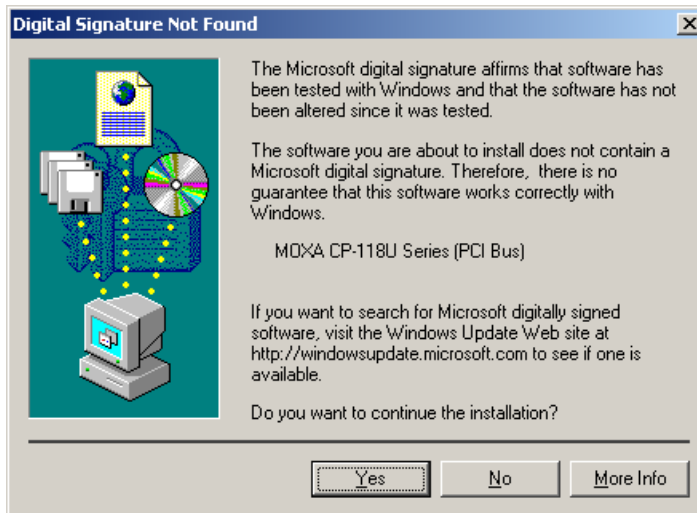

7. Windows will install the drivers. When the installation is complete, click **Finish**.

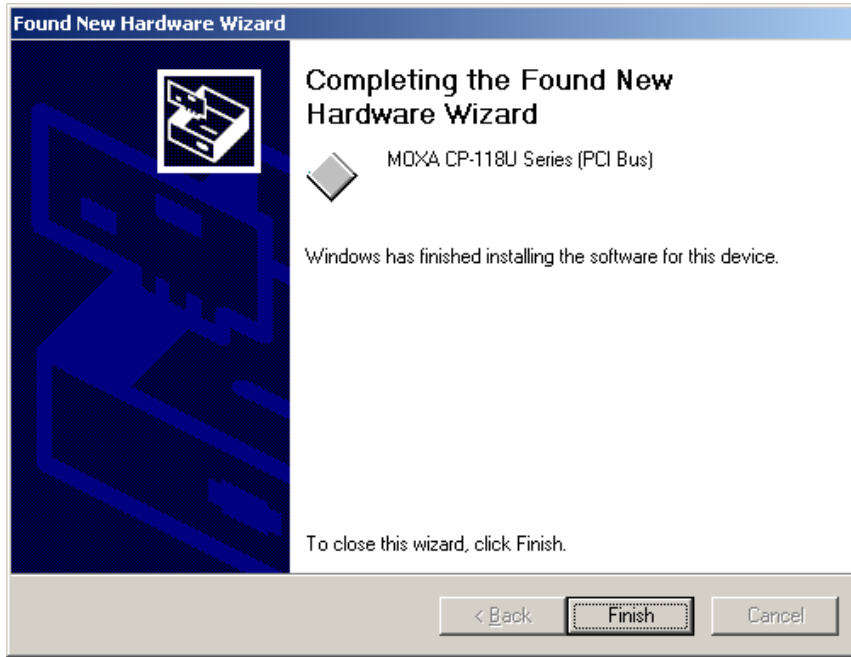

## Installing the Ports

After the board and drivers have been installed, an installation wizard will guide you through installation of the newly added serial ports, starting with port 0.

1. When the installation wizard opens, click **Next** to proceed.



2. Select **Search for a suitable driver for my device (recommended)** and click **Next** to continue.



3. Select **Specify a location** and click **Next** to continue.

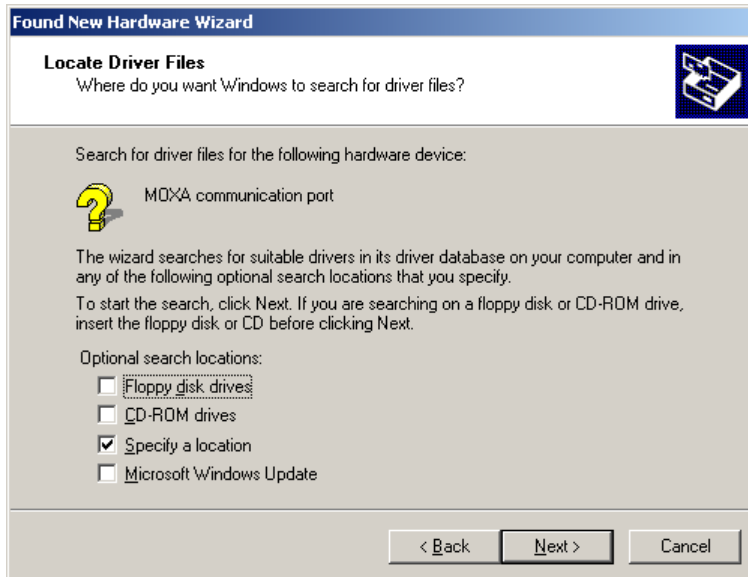

4. Click **Browse** and select the appropriate directory on the Document & Software CD for the driver. Drivers for all operating systems are located under the product folder in the **\Software** directory (e.g., under **\CP-118U Series\Software**). Select the **\Windows 2K** folder and click **Next** to continue.

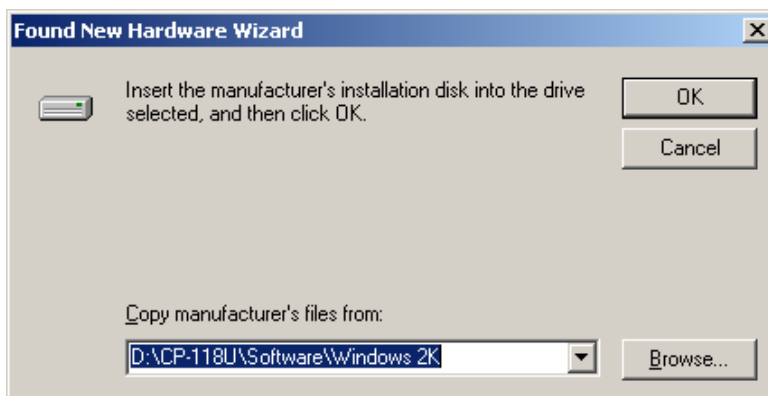

- After the wizard has located the driver files, click **Next** to proceed.

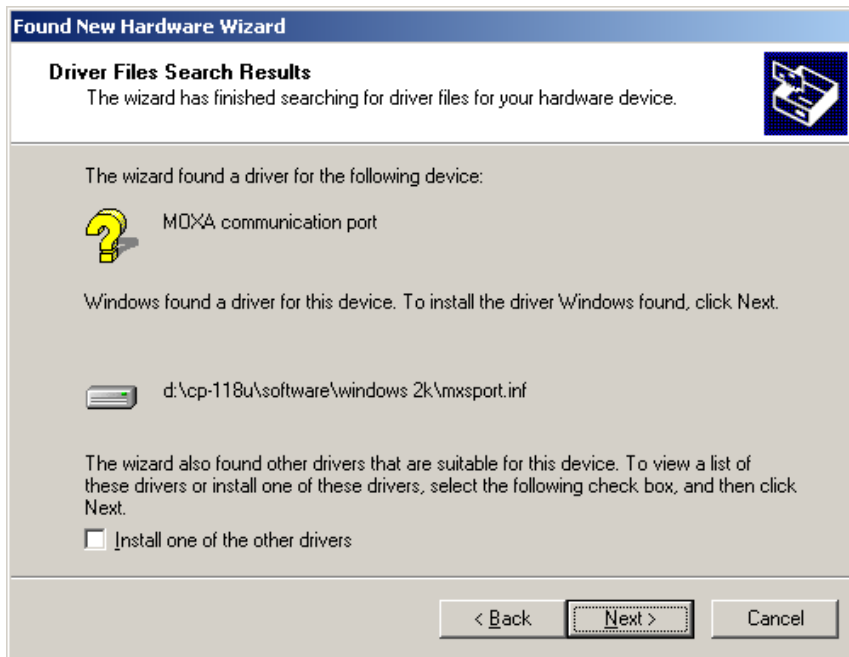

- After the drivers have been installed, click **Finish** to exit the wizard. The other serial ports will automatically install in the background.

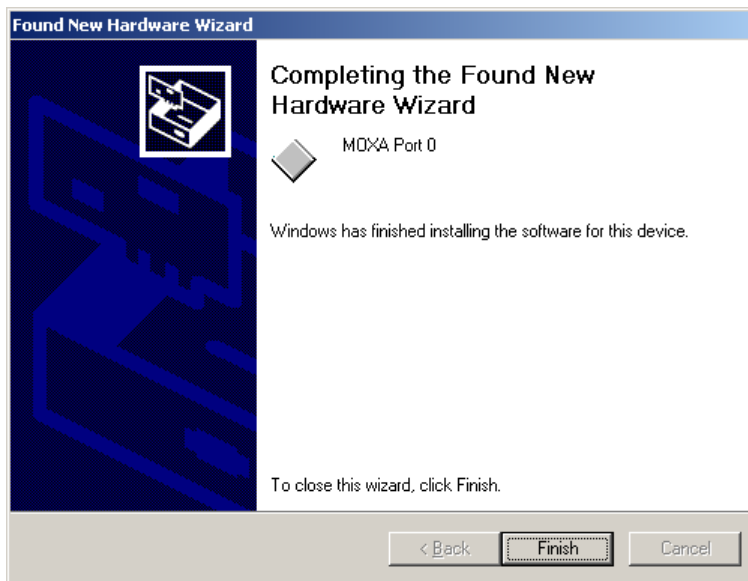

## Verifying the Installation

You can use Windows Device Manager to verify proper installation of the board.

- Right-click **My Computer** and select **Properties** in the context menu.

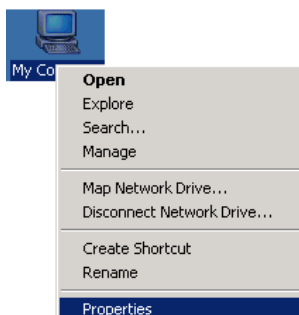

- In the Hardware tab, click **Device Manager**.

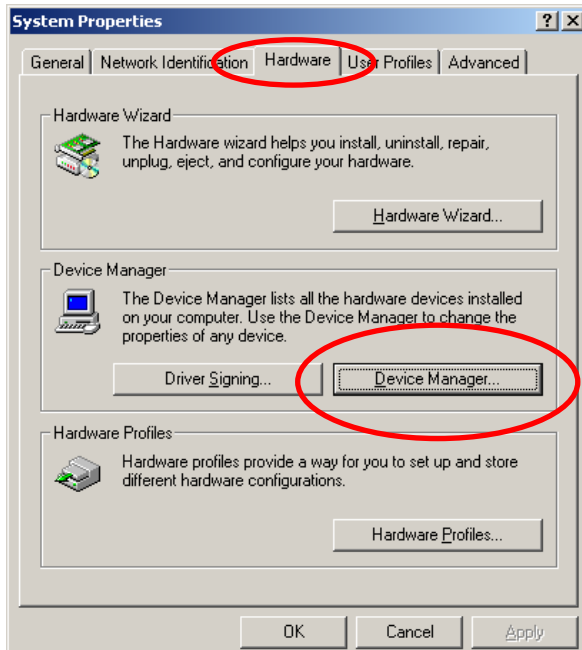

- In the **Device Manager** window, you should see your UPCI board under **Multi-port serial adapters** (CP-118U in this example). You should also see Moxa communication ports under **Ports (COM & LPT)**.

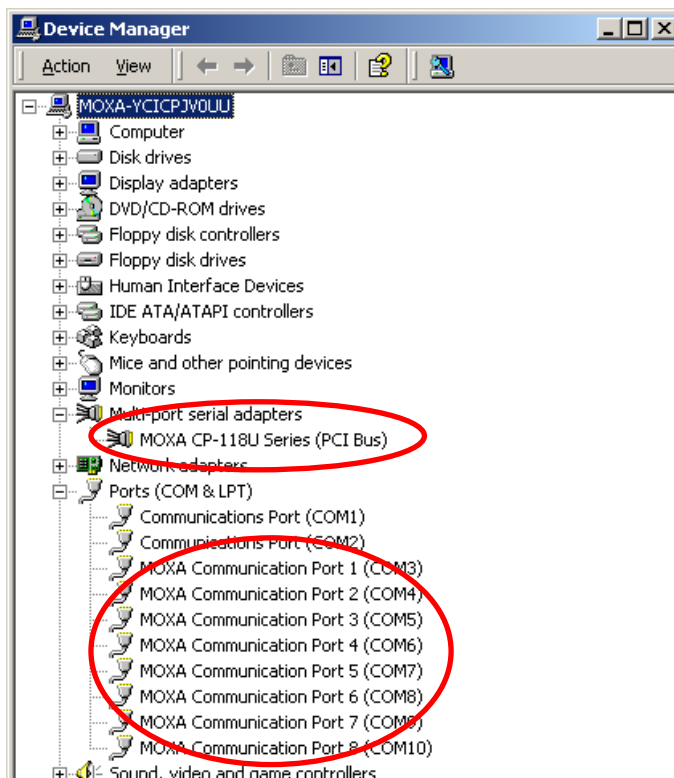

- If you see any special marks, such as a question mark or an exclamation mark, next to the Moxa items, the installation of the board was not successful. Examine the Windows event log for details.

# Configuring the Ports

After the board and serial port drivers are installed, the board's **Properties** window will appear. The system will map the ports automatically. You may be prompted to take care of port configuration if other Moxa boards have been installed.

1. On the **Ports Configuration** tab, select a port to configure and click **Port Setting**.

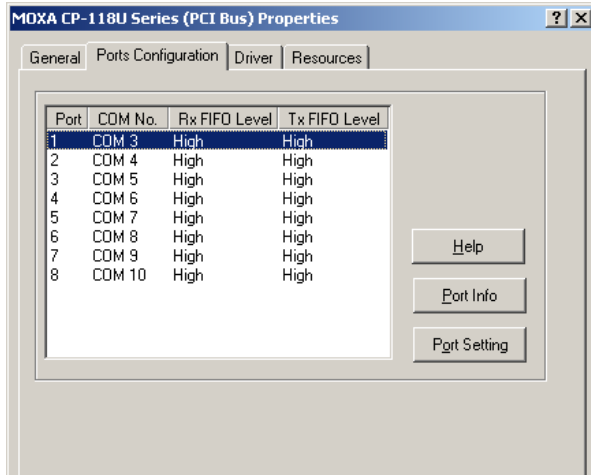

2. Under **Port Number**, select a COM number to assign to the serial port. Select **Auto Enumerating COM Number** to map subsequent ports in numerical order. For example, if COM 3 is assigned to Port 1, then COM 4 will be automatically assigned to Port 2.

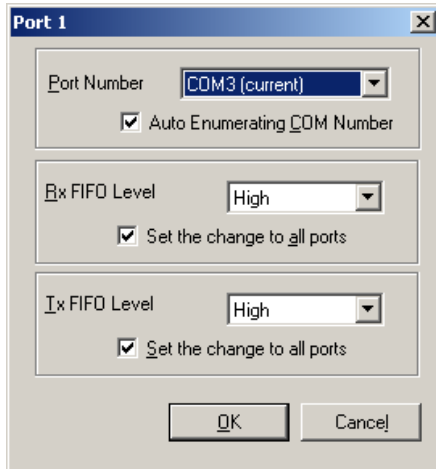

3. Select an **Rx FIFO Trigger** and **Tx FIFO Size**. The default Rx FIFO Trigger is 120 bytes (high level). The default Tx FIFO Size is 128 bytes (high level). Select **Set the change to all ports** to use this setting for all serial ports on the board.

	Tx FIFO	Rx FIFO
<b>High</b>	128	120
<b>Middle</b>	64	60
<b>Low</b>	1	1

4. Click **OK** to approve the settings for the selected port. Continue in the same way to configure the other ports. When you have finished setting up the ports, click **OK** to close the **Properties** window and apply the new port settings.



## Using PComm

PComm Diagnostic is a useful program for checking the board's status. It provides internal and external testing of IRQ, TxD/RxD, UART, CTS/RTS, DTR/DSR, and other items. You can use PComm Diagnostic to verify that the module and serial ports are working properly.

You may download PComm from the Moxa website.

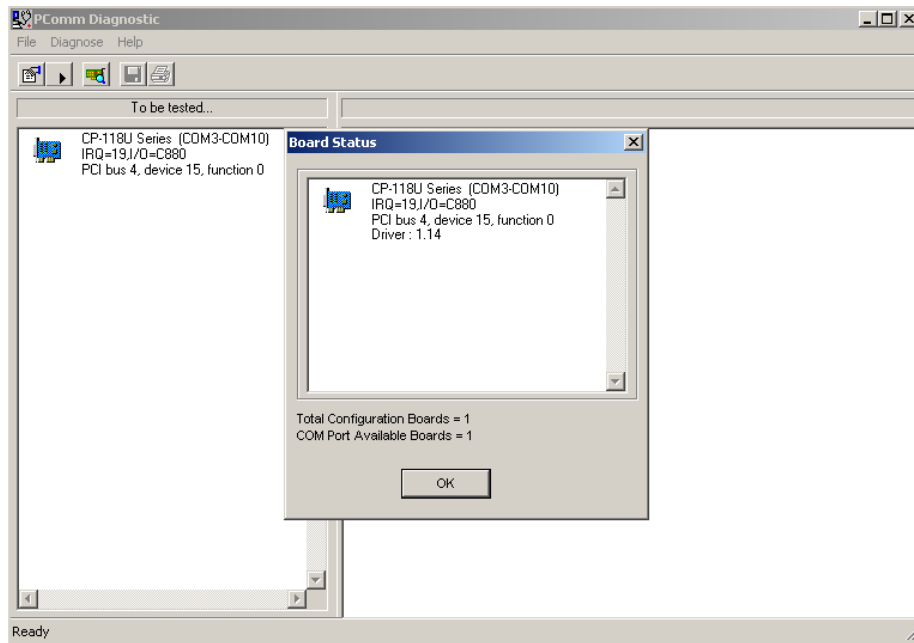

## Using Event Log

You may refer to the Windows event log to verify operation of the board. To view the event log, open Event Viewer, which is located under Administrative Tools in the Control Panel. Information about the board will be located under the System category.

# Disabling the Board

1. Right-click **My Computer** and select **Properties** in the context menu.

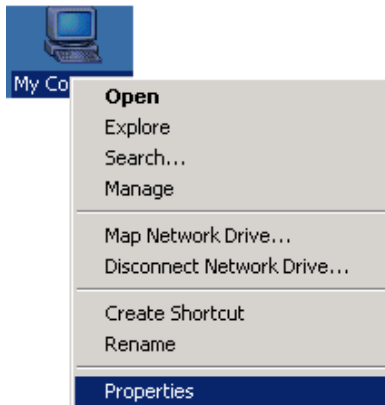

2. In the **Hardware** tab, click **Device Manager**.

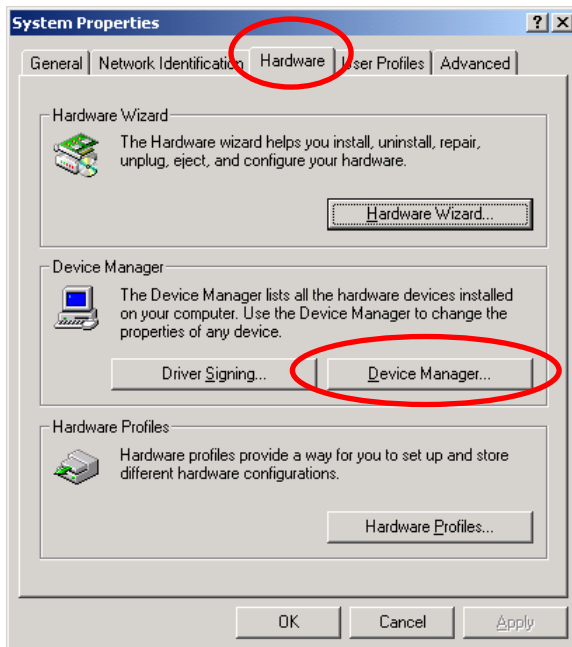

3. In **Device Manager**, right-click the UPCI board under **Multi-port serial adapters** and select **Disable** in the context menu. This will disable the board.

# Uninstalling the Board

1. Right-click **My Computer** and select **Properties** in the context menu.

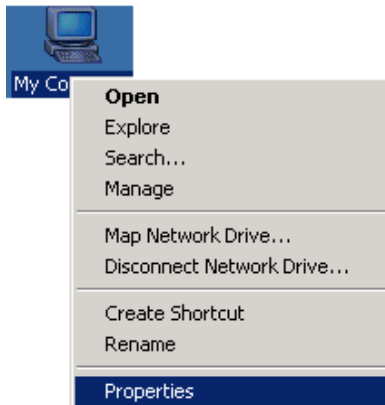

2. In the **Hardware** tab, click **Device Manager**.

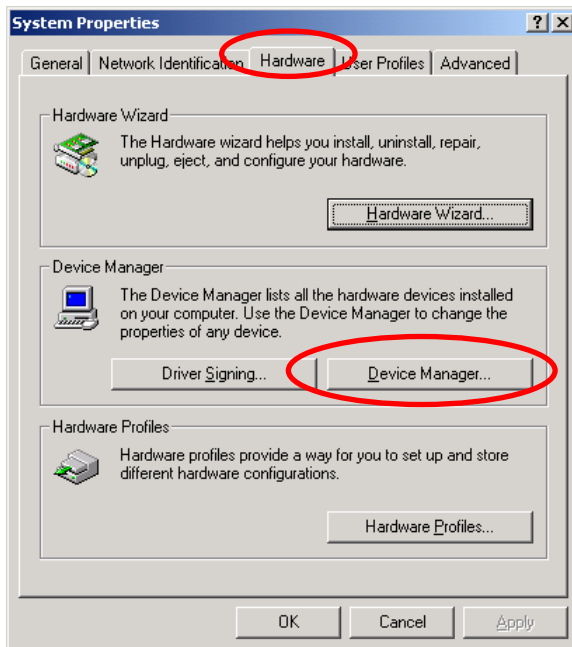

3. Right-click the UPCI board under **Multi-port serial adapters** (CP-118U in this example) and select **Uninstall** in the context menu.

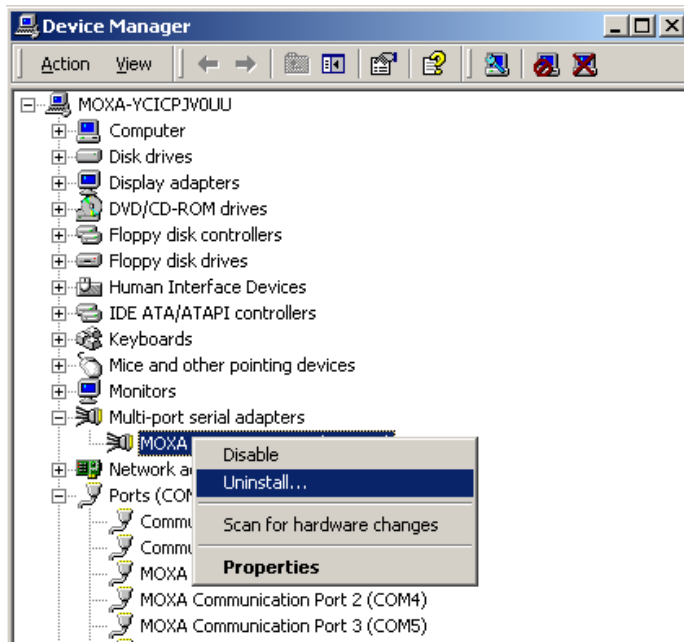

4. At the warning prompt, click **OK** to uninstall the device.

## Driver Installation: Windows NT

---

The following topics are covered in this chapter:

- **Overview**
- **Installing the Driver**
- **Configuring the Ports**
- **Removing the Board**
- **Updating the Driver**
- **Removing the Driver**

# Overview

This chapter explains how to install, configure, update, and remove the board drivers for Windows NT. The following models are supported:

2 Ports	4 Ports	8 Ports
CP-112UL / CP-112UL-I	CP-114UL / CP-114UL-I	CP-118U / CP-118U-I
CP-132UL / CP-132UL-I	CP-134U / CP-134U-I	CP-138U / CP-138U-I
CP-102UL	CP-104UL	CP-168U
CP-102U	CP-104JU	
CP-102UF	POS-104UL	

Windows NT supports up to 256 serial ports, from COM1 to COM256. Moxa developed pure 32-bit Windows device drivers in order to fully utilize the advanced multi-process and multi-thread features of Windows NT. The drivers conform to the Win32 COMM API standard.

You can download the drivers from the Moxa website. For information on developing your own serial programming applications, please refer to Chapter 9.

Before installing the software, be sure to install the hardware first. For details on installing the hardware, please refer to Chapter 2.

The overall procedure for installing the drivers is shown on the right. Windows NT will not automatically detect a newly installed board. You will need to manually add the board in the operating system.

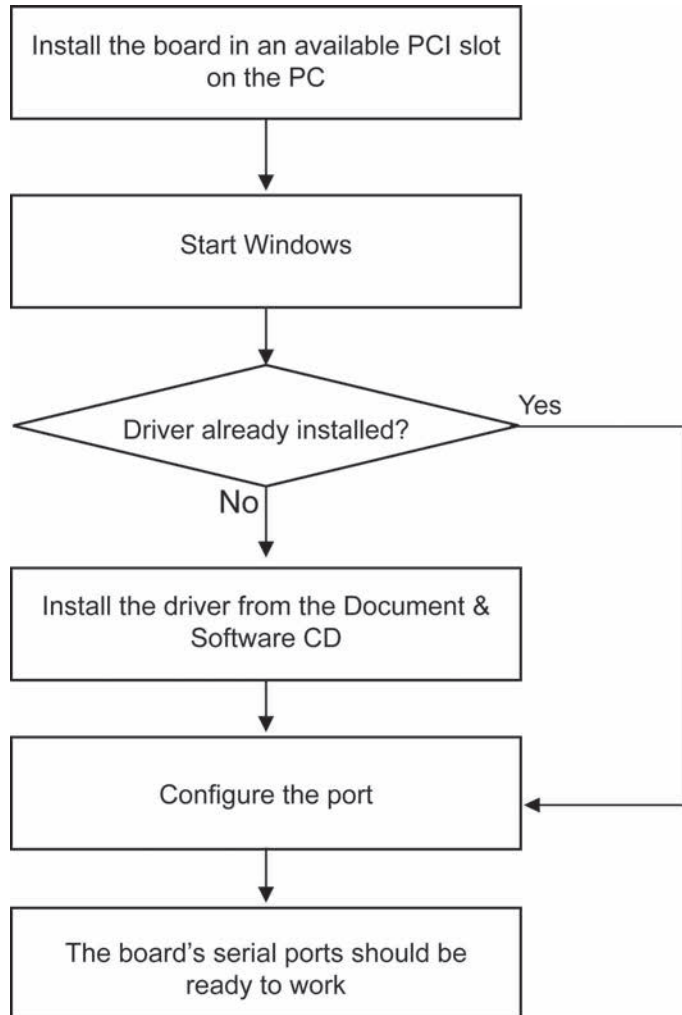

# Installing the Driver

You will need to plug the board in an available PCI or PCI-X slot first, before installing the driver. Note that these instructions use the CP-168U as an example. The procedure for installing all models is the same.

1. Log into Windows NT as Administrator.

Locate the appropriate folder for your board's drivers on the Document & Software CD. The NT drivers will be located under the product folder in the **\Software\WinNT** directory (e.g., under \CP-118U Series\Software). Copy this folder to the PC's hard disk and remember its location.

In the **Control Panel**, open **Network** applet. On the **Adapters** tab, click **Add**. When prompted to select a product, click **Have Disk...**

You will be prompted to enter the path to the driver. Enter the location of the drivers that you copied from the Document & Software CD (**C:\Windows.nt** in this example) and then click **OK**.

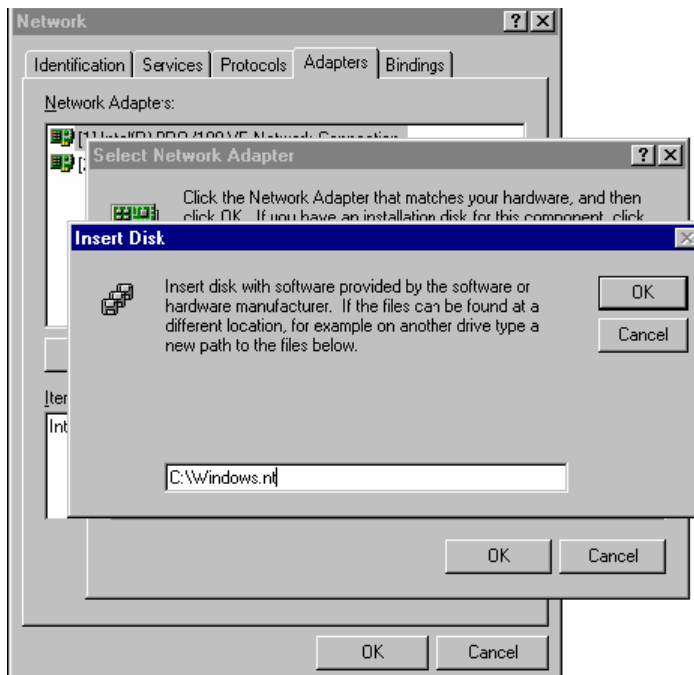

2. When prompted, select your board model (**Smartio/Industio Family multiport board** in this example) and click **OK**.

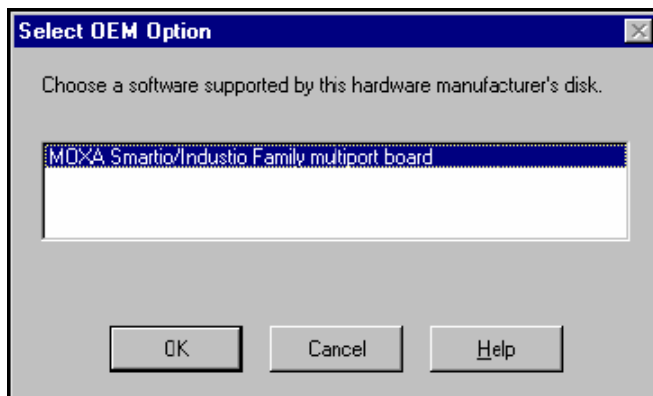

3. After the files have been installed, a configuration panel will open. This is where boards are installed, configured, and removed. If another board has already been installed on the system, it will already be listed. Windows NT does not automatically detect Moxa UPCI boards, so you will need to click **Add** for a newly installed board.

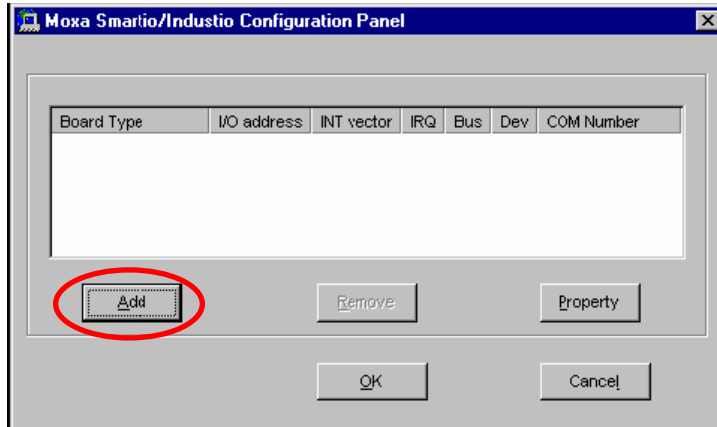

4. Under **Board Type**, select the UPCI board that is being installed. The window will show the COM settings for the serial ports on the board. You can modify the COM settings for any port at this time by selecting a port and clicking **Port Setting**. If you are satisfied with the COM settings, click **OK** to return to the configuration panel.

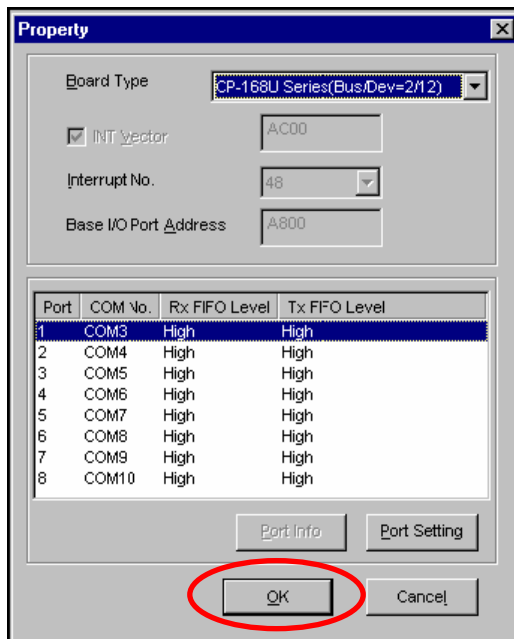



- The board will now appear in the configuration panel (**CP-168U Series in this example**). Click **OK** to return to the Network applet. After that, click **OK** again to exit the Network applet

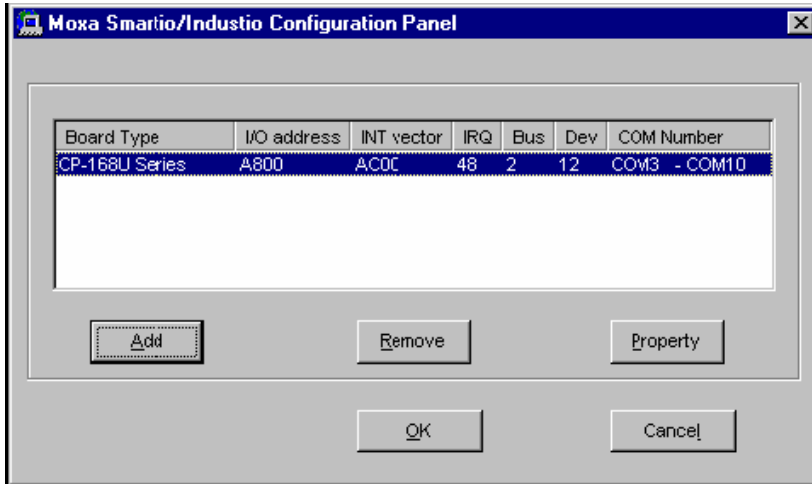

- Restart the PC. After you have logged back into Windows NT, you may check the event log issued by the Moxa driver to see if the board's ports have been initialized successfully. In the **Administrative** group, open **Event Viewer** and select **Log and System**. For each newly installed or configured Moxa UPCI board, check for a message stating that the board has been enabled (e.g., "Moxa CP-168U board, with first serial port COM3, has been enabled").



**ATTENTION**

The driver configuration will NOT take effect until you restart the PC. Double check that all CP-168U board components are connected and fastened tightly to ensure that the system and the driver can start up successfully.

# Configuring the Ports

1. In Windows **Control Panel**, open the **Network** applet. In the **Adapters** tab, UPCI boards will appear as a type of Moxa adapter (**Moxa Smartio/Industio Family Adapter** in this example). Select the Moxa adapter and click **Properties...**

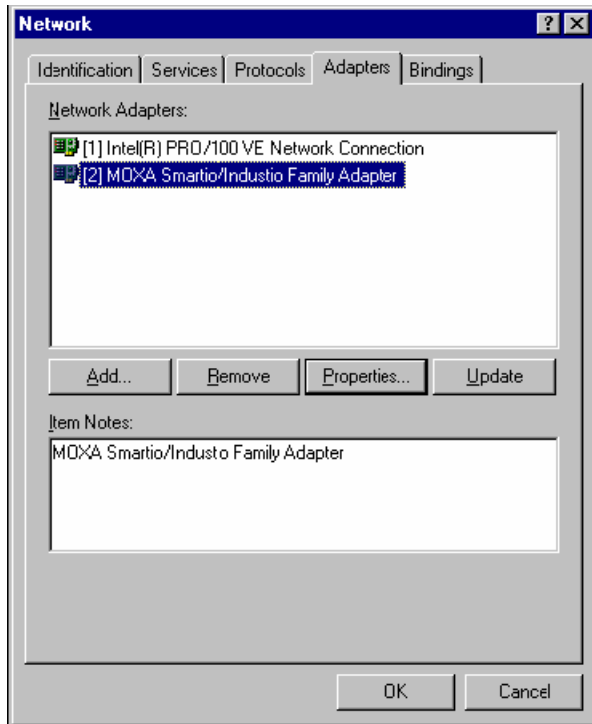

2. The configuration panel will open with a list of installed boards. Select your board and click **Property**. Up to 4 Moxa UPCI boards can be installed at a time.

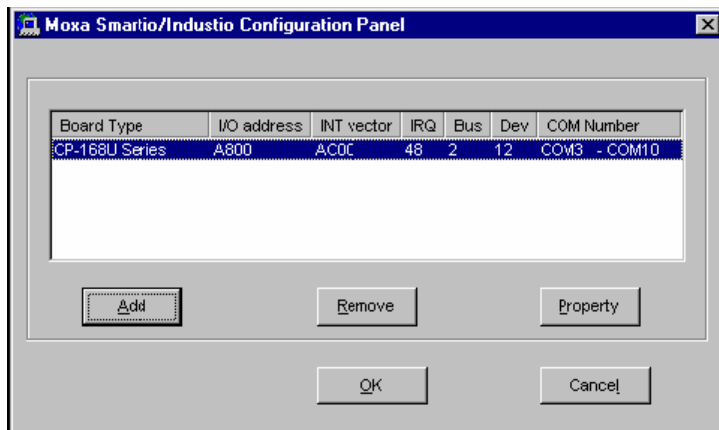

3. Select a port to configure and click **Port Setting**.

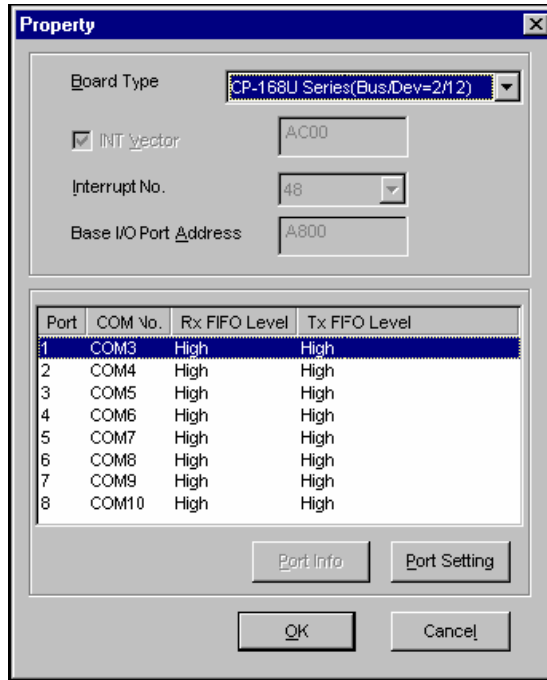

4. Under **Port Number**, select a COM number to assign to the serial port. Select **Auto Enumerating COM Number** to map subsequent ports in numerical order. For example, if COM 3 is assigned to Port 1, then COM 4 will be automatically assigned to Port 2.

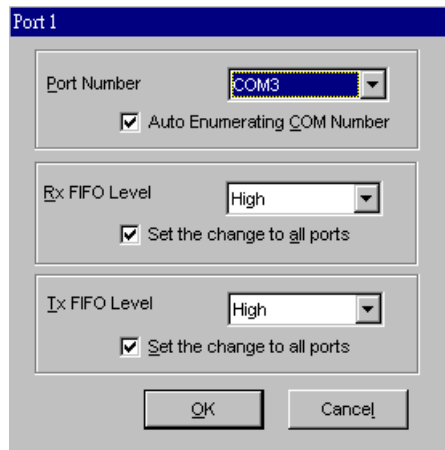

Select an **Rx FIFO Trigger** and **Tx FIFO Size**. The default Rx FIFO Trigger is 120 bytes (high level). The default Tx FIFO Size is 128 bytes (high level). Select **Set the change to all ports** to use this setting for all serial ports on the board.

	Tx FIFO	Rx FIFO
<b>High</b>	128	120
<b>Middle</b>	64	60
<b>Low</b>	1	1

- Click **OK** to approve the settings for the selected port. Continue in the same way to configure the other ports. When you have finished setting up the ports, click **OK** to close the **Properties** window and apply the new port settings. Click **OK** again to exit the Network applet.

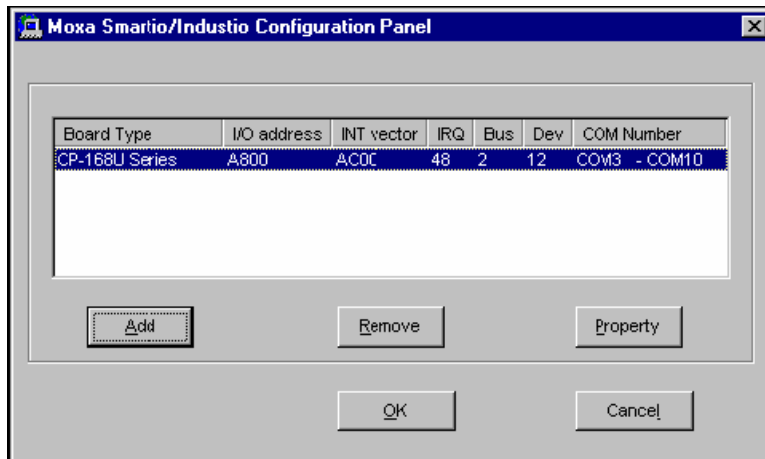

## Removing the Board

To remove a board, shut of your PC and physically remove the board from the PCI slot. The next time you start up the PC, Windows NT will automatically remove the configuration. You do not need to go through the Windows control panel.

## Updating the Driver

- In Windows **Control Panel**, open the **Network** applet. In the **Adapters** tab, UPCI boards will appear as a type of Moxa adapter (**Moxa Smartio/Industio Family Adapter** in this example). Select the Moxa adapter and click **Remove**.

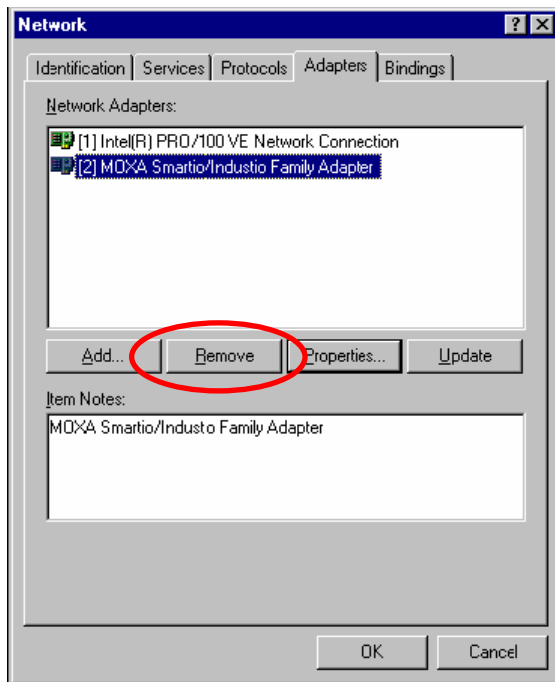

- Restart** the system. Go through the process of installing the drivers using the new drivers.

## Removing the Driver

1. In Windows **Control Panel**, open the **Network** applet. In the **Adapters** tab, UPCI boards will appear as a type of Moxa adapter (**Moxa Smartio/Industio Family Adapter** in this example). Select the Moxa adapter and click **Remove**.

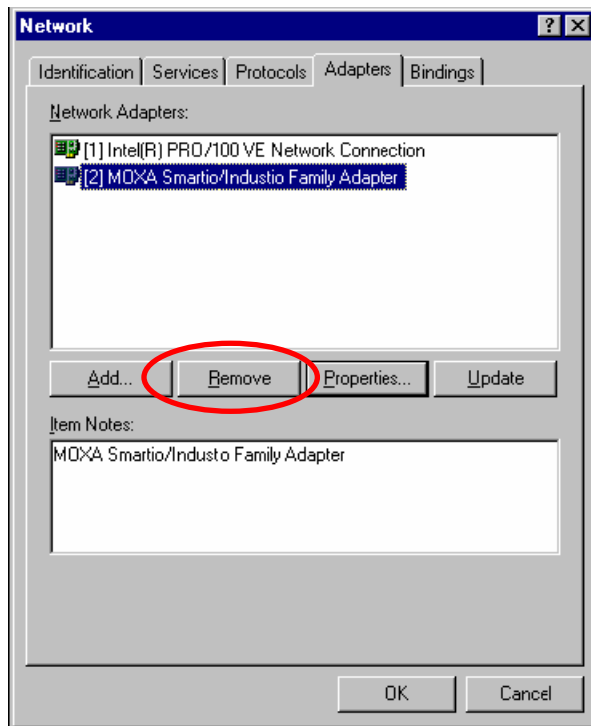

2. Click **OK** to exit the Network applet and restart the system.

# Driver Installation: Windows 95/98/ME

---

The following topics are covered in this chapter:

- **Overview**
- **Installing the Driver**
  - Windows 95
  - Windows 98 and ME
- **Configuring the Ports**
- **Updating the Driver**
- **Removing the Driver**

# Overview

This chapter explains how to install, configure, update, and remove the board drivers for Windows 95/98/ME. The following models are supported:

2 Ports	4 Ports	8 Ports
CP-112UL / CP-112UL-I	CP-114UL / CP-114UL-I	CP-118U / CP-118U-I
CP-132UL / CP-132UL-I	CP-134U / CP-134U-I	CP-138U / CP-138U-I
CP-102UL	CP-104UL	CP-168U
CP-102U	CP-104JU	
CP-102UF	POS-104UL	

Windows 95/98/ME supports up to 128 serial ports, from COM1 to COM128. In order to fully utilize the advanced multi-process and multi-thread features of Windows 95/98/ME, Moxa developed pure 32-bit virtual device port drivers (VxD) that are compliant with communication drivers (VCOMM). The drivers conform to the Win32 COMM API standard.

You can download the drivers from the Moxa website. For information on developing your own serial programming applications, please refer to Chapter 9.

Before installing the software, be sure to install the hardware first. For details on installing the hardware, please refer to Chapter 2.

The overall procedure for installing the drivers is shown on the right. A newly installed board will be automatically detected by the operating system.

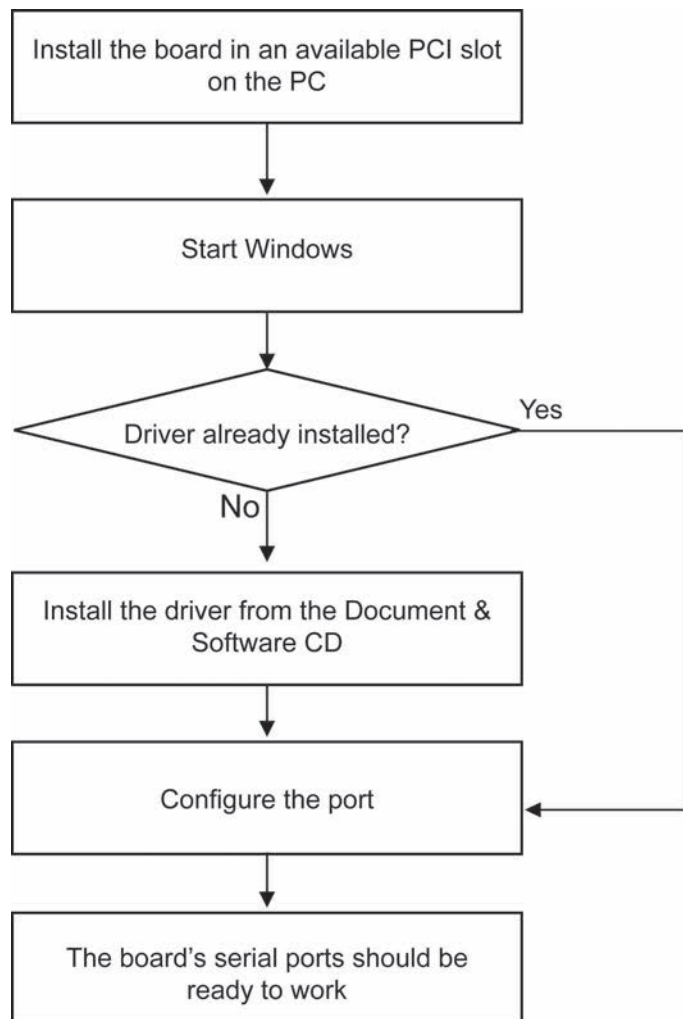

# Installing the Driver

The following instructions show how to install the driver for the first time under Windows 95/98/ME. You will need to plug the board in an available PCI or PCI-X slot first, before installing the driver.



## ATTENTION

The following steps will not be necessary if a Moxa UPCI board was already installed on your computer. Windows will automatically detect and install any additional board(s) at bootup. In this case, you may proceed directly to configuring the ports.

## Windows 95

1. After the board is physically installed and the PC boots up, Windows will automatically detect the new board and the Found New Hardware Wizard window will open. Click **Next** to continue.

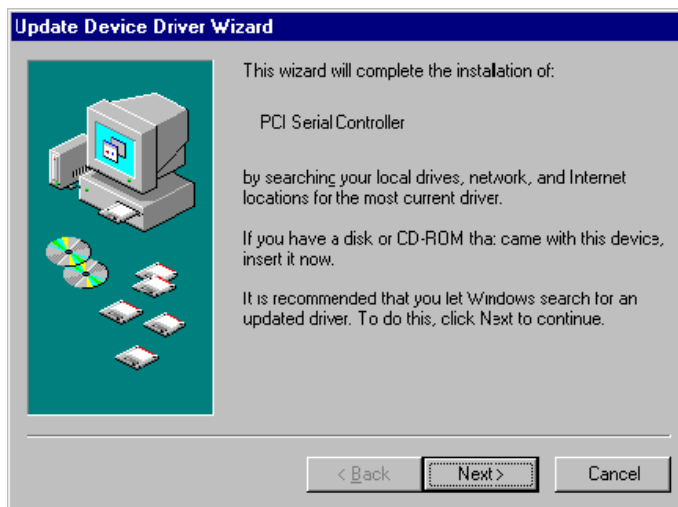

2. Select **Other Locations...**





3. Click **Browse** and select the appropriate directory on the Document & Software CD for the driver. Drivers for all operating systems are located under the product folder in the **\Software** directory (e.g., under **\CP-168U \Software**). Select the **\Win9x** folder and click **OK** to continue.

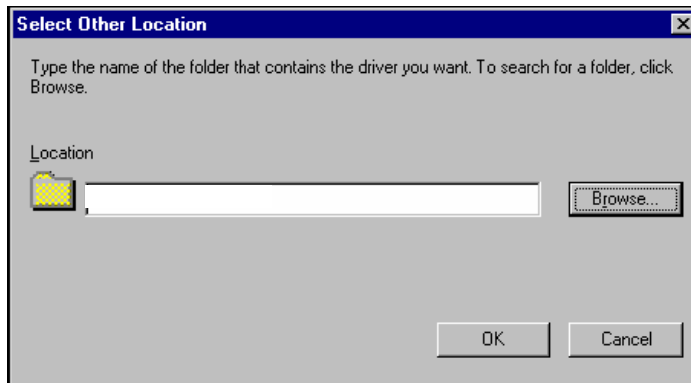

4. After Windows finds the drivers, click **Finish**.



5. You may begin configuring and using the new COM ports right away without restarting Windows.

## Windows 98 and ME

1. After the board is physically installed and the PC boots up, Windows will automatically detect the new board and the Found New Hardware Wizard window will open. Click **Next** to continue.

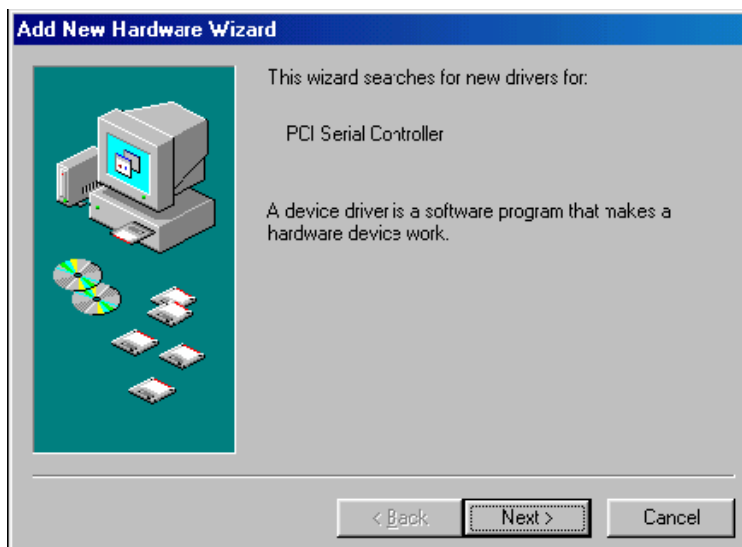

2. Select **Display a list...** and click **Next**.



3. Select **Other Devices** and click **Next**.

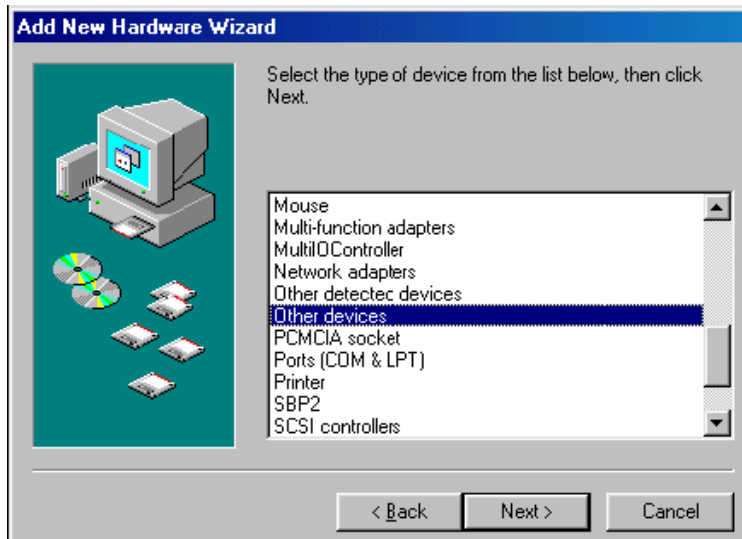

4. Select **Have Disk...**

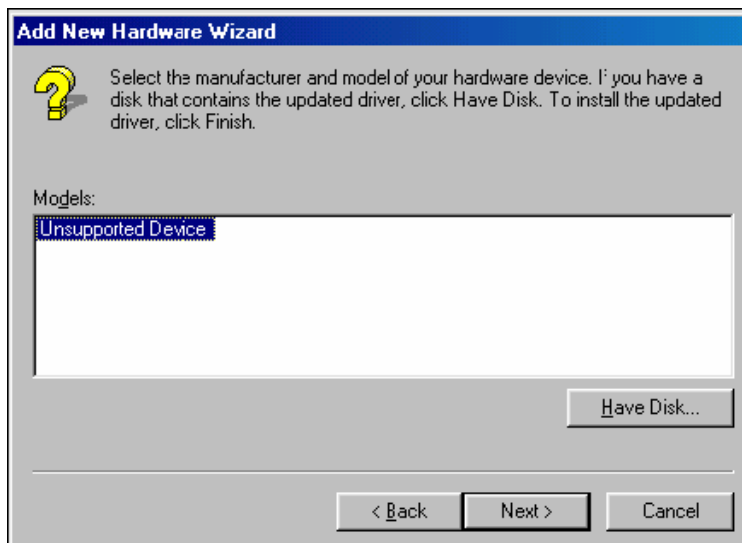

- Click **Browse** and select the appropriate directory on the Document & Software CD for the driver. Drivers for all operating systems are located under the product folder in the **\Software** directory (e.g., under \CP-168U \Software). Select the **\Win9x** folder and click **OK** to continue.

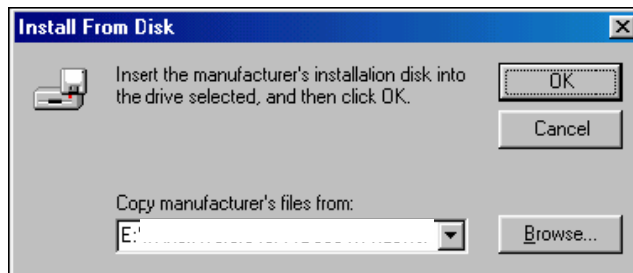

- After Windows installs the drivers, click **Finish**.

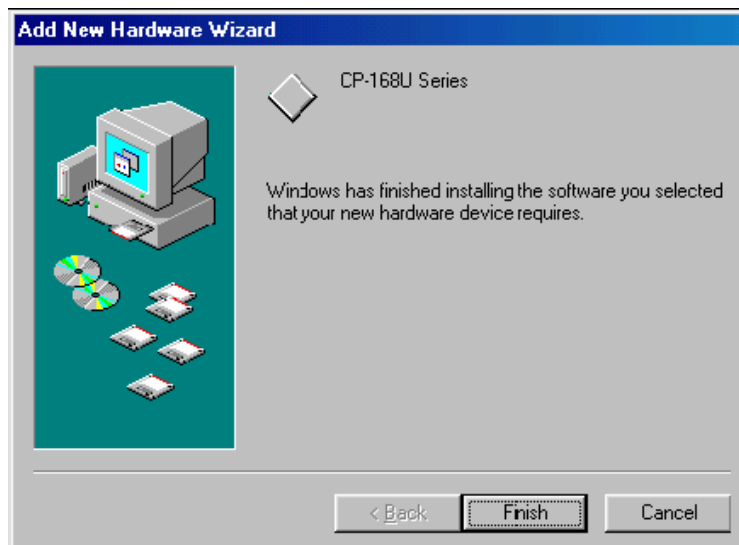

# Configuring the Ports

You may configure the COM ports after the board and drivers have been installed.

1. In the Windows **Control Panel**, open the **System** applet.

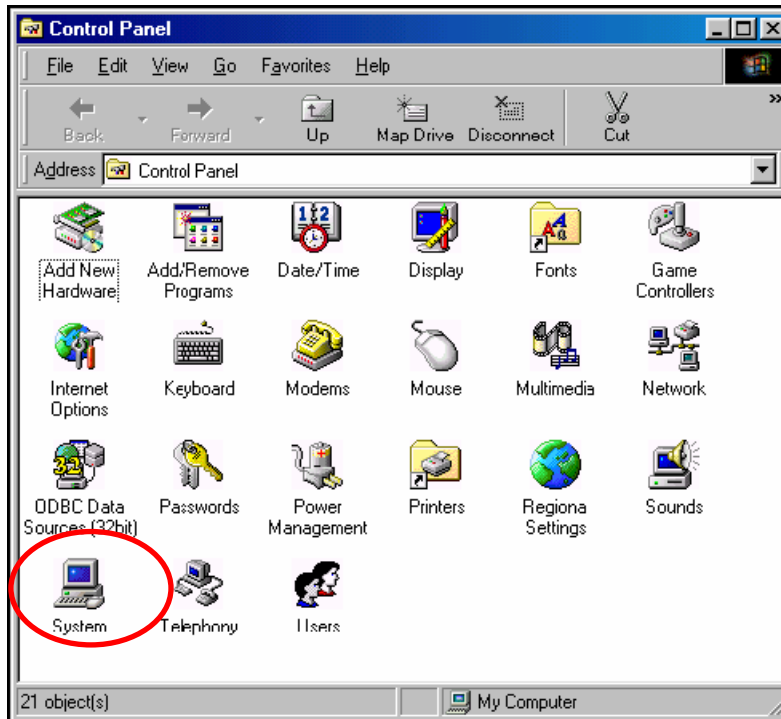

2. In the **Device Manager** tab, expand the **Moxa Smartio/Industio multiport board** category by clicking the "+" sign next to it. Select the desired board (CP-168U in this example) and click **Properties**.

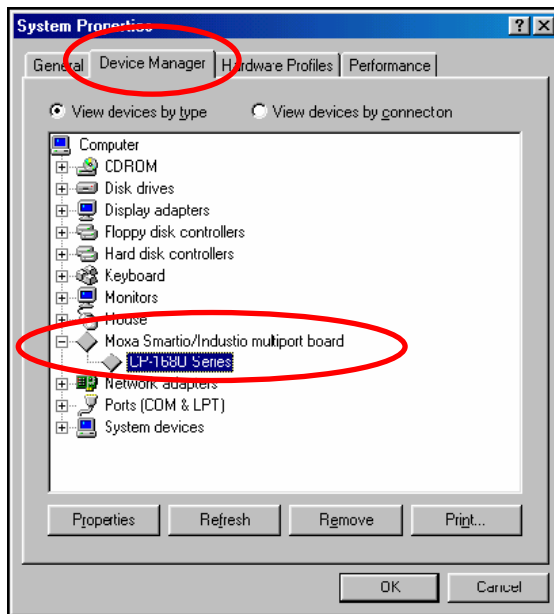

- On the **Ports Configuration** tab, select a port to configure and click **Port Setting**.

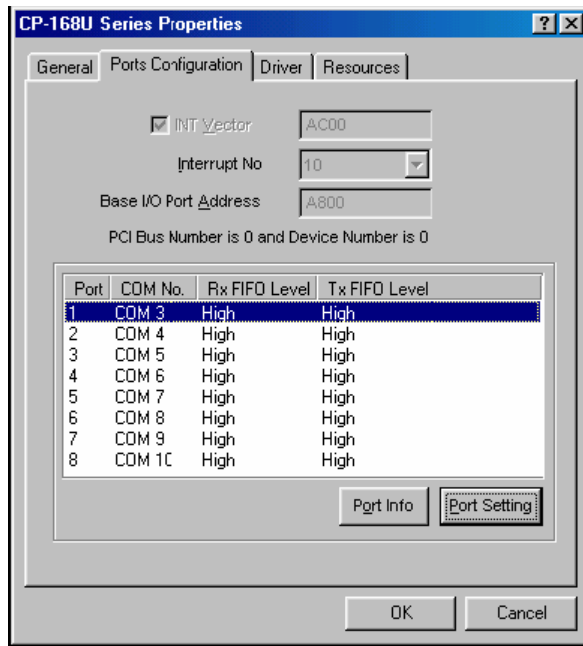

- Under **Port Number**, select a COM number to assign to the serial port. Select **Auto Enumerating COM Number** to map subsequent ports in numerical order. For example, if COM 3 is assigned to Port 1, then COM 4 will be automatically assigned to Port 2.

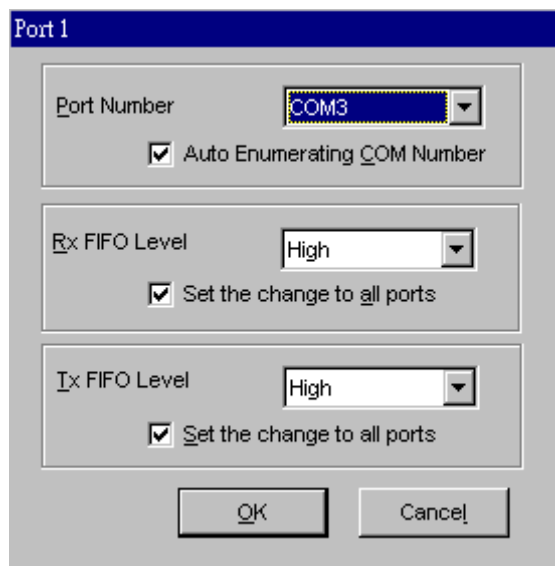

Select an **Rx FIFO Trigger** and **Tx FIFO Size**. The default Rx FIFO Trigger is 120 bytes (high level). The default Tx FIFO Size is 128 bytes (high level). Select **Set the change to all ports** to use this setting for all serial ports on the board.

	Tx FIFO	Rx FIFO
<b>High</b>	128	120
<b>Middle</b>	64	60
<b>Low</b>	1	1

- Click **OK** to approve the settings for the selected port. Continue in the same way to configure the other ports. When you have finished setting up the ports, click **OK** to close the **Properties** window and apply the new port settings. Click **OK** again to close the **Device Manager** and restart the system.

# Updating the Driver

You may configure the COM ports after the board and drivers have been installed.

1. In the Windows **Control Panel**, open the **System** applet.

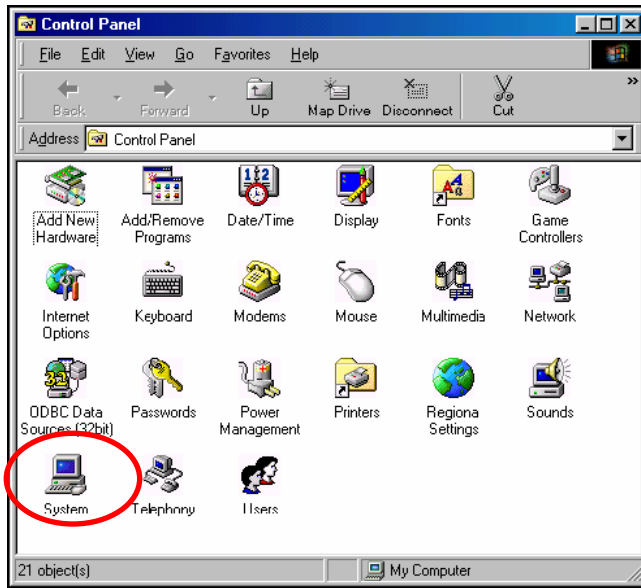

2. In the **Device Manager** tab, expand the **Moxa Smartio/Industio multiport board** category by clicking the "+" sign next to it. Select the desired board (CP-168U in this example) and click **Properties**.

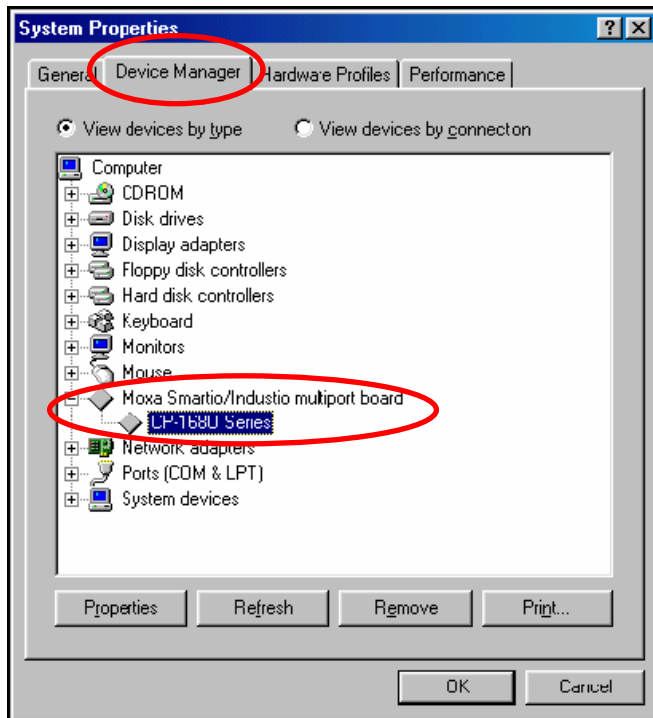

3. In the **Driver** tab, click **Update Driver....**

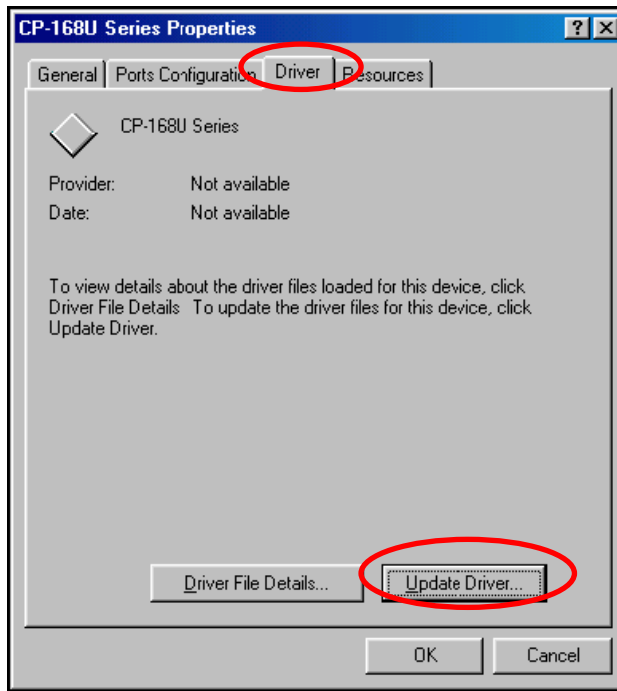

4. Select the appropriate model (CP-168U in this example) and click **Have Disk...**

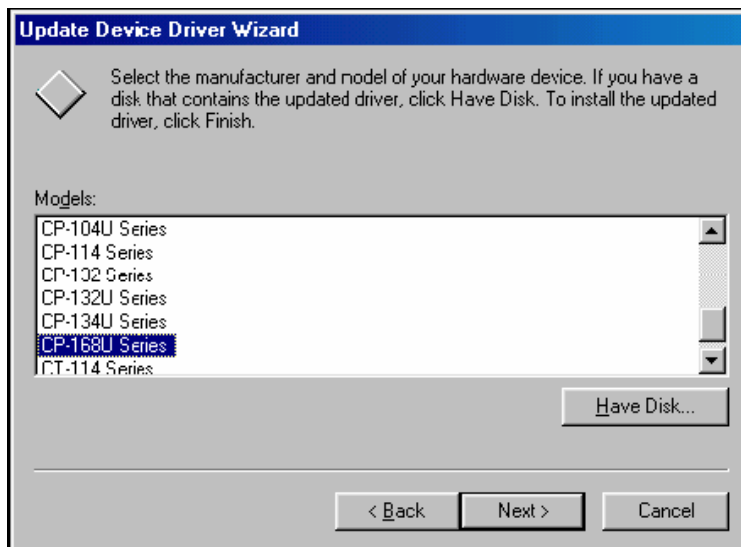

5. When prompted, select the appropriate directory on the Document & Software CD for the driver. Drivers for all operating systems are located under the product folder in the **\Software** directory (e.g., under **\CP-118U Series\Software**). Select the **\Win9x** folder and click **OK** to continue.
6. You will be prompted to restart the system. The new drivers will be in effect the next time you restart.

# Removing the Driver

1. In the Windows Control Panel, open the **Add/Remove Programs** applet. On the Install/Uninstall tab, select **Moxa Smartio/Industio Driver** and click **Add/Remove**.

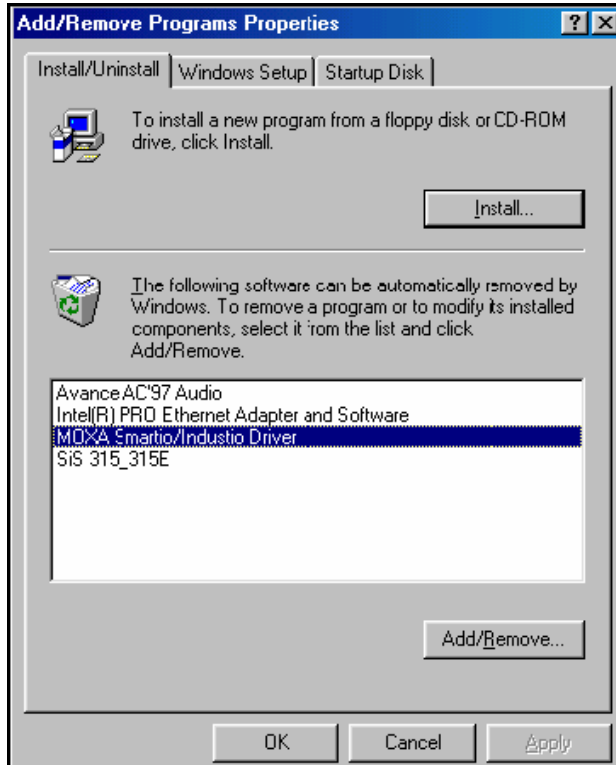

2. When prompted, click **Yes** to confirm that you want to remove the driver.

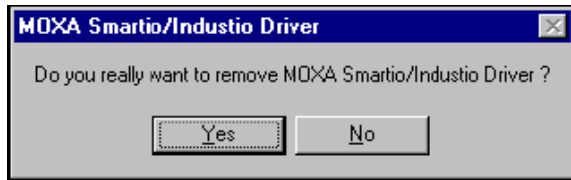

3. After the driver has been removed, click **OK** to return to the **Add/Remove Programs** applet.





## Driver Installation: Windows CE

---

The following topics are covered in this chapter:

- ❑ **Windows CE 5.0**
  - Installing the Driver
- ❑ **Windows CE 6.0 Installation**

# Windows CE 5.0

In this section, we explain how to install Moxa Universal PCI boards under WinCE 5.0. These instructions are intended for users who are familiar with the Windows CE Platform Builder 5.0 Toolkit, and would like to install one or more Moxa Tech products. Here, we only give the step-by-step installation instructions for the development environment. You will need to download the image file to the target host yourself.

The CP-104UL board is used to illustrate the installation procedure.

## Installing the Driver

The following procedure explains how to install the CP-104UL multiport serial module driver under WinCE.

Obtain a copy of Moxa Tech WinCE 5.0 driver package and extract it to your computer. Double click the Install package to copy the **Mxser** folder to %WINCEROOT%\PLATFORM\ automatically, and import the supported Moxa Tech products into the **Folder**.

1. Start WinCE Platform Builder, select **File**, and open **New Platform**.

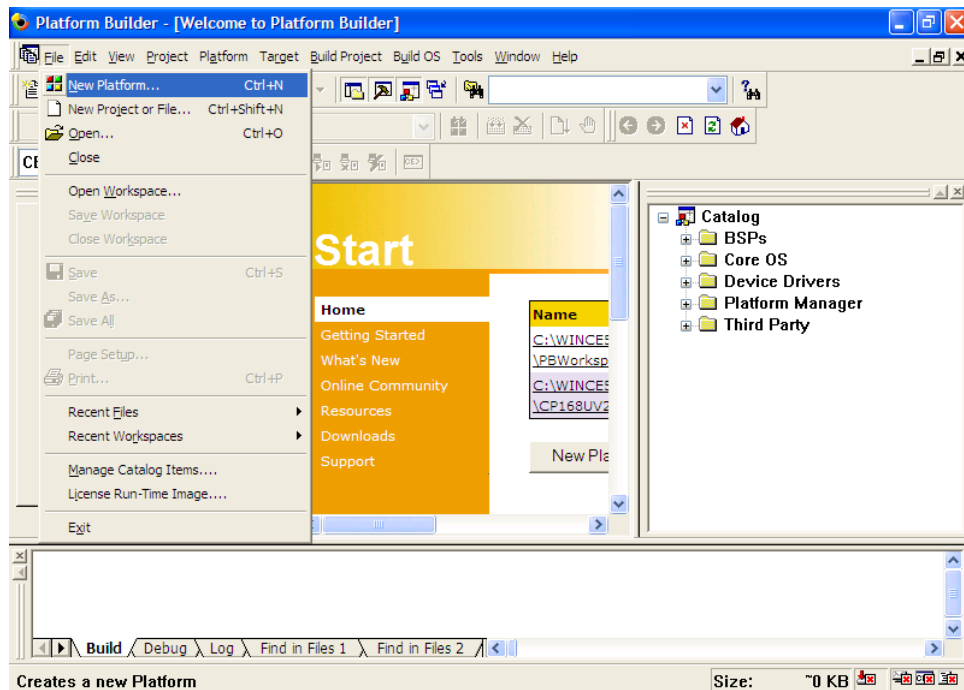

2. Enter a Name for Workspace and press **Next**.

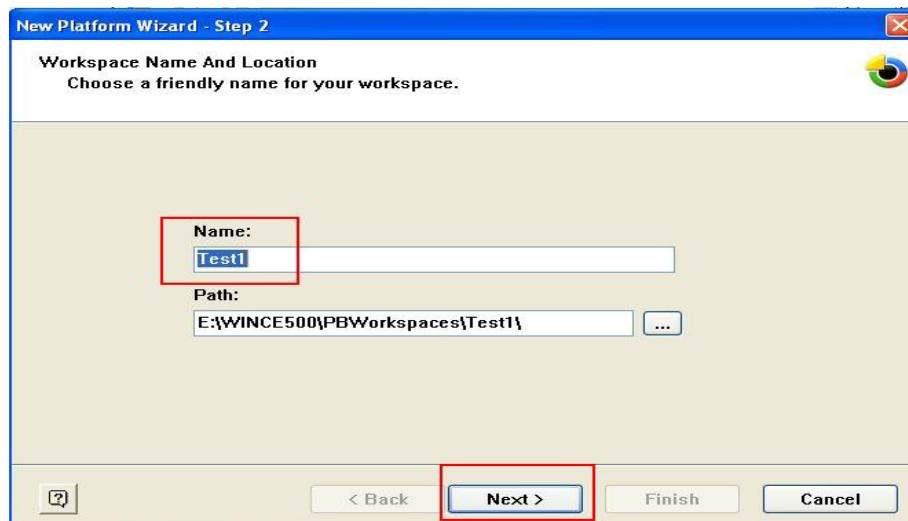

- When you see **Board Support Packages, Design Template, Applications & Media, Networking & Communications, OBEX Server**, select what you need to build your own environment. The **Completing the New Platform Wizard** window will open to indicate that it has finished creating a new platform. Click **Finish** to complete the setup.

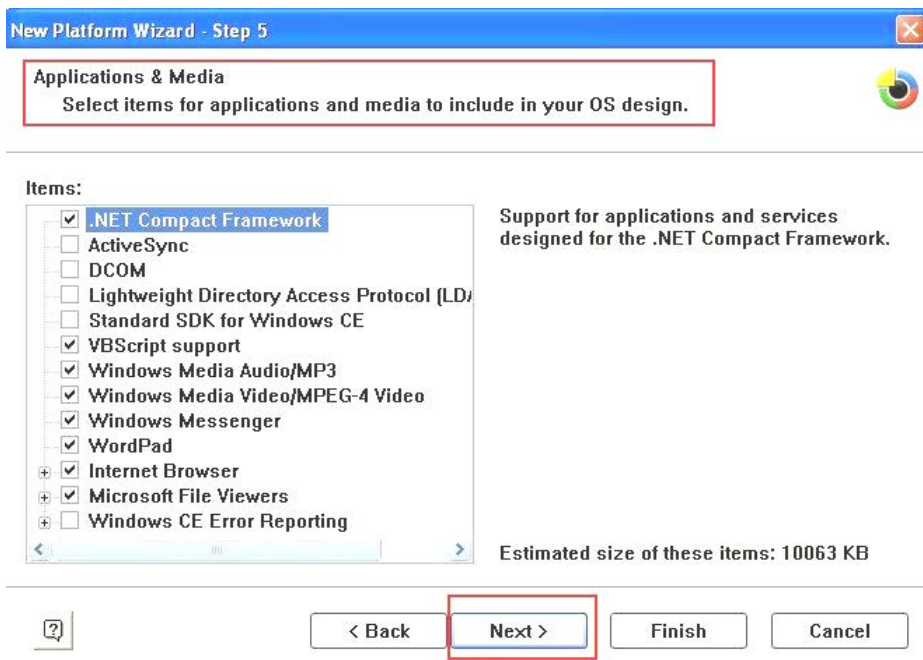
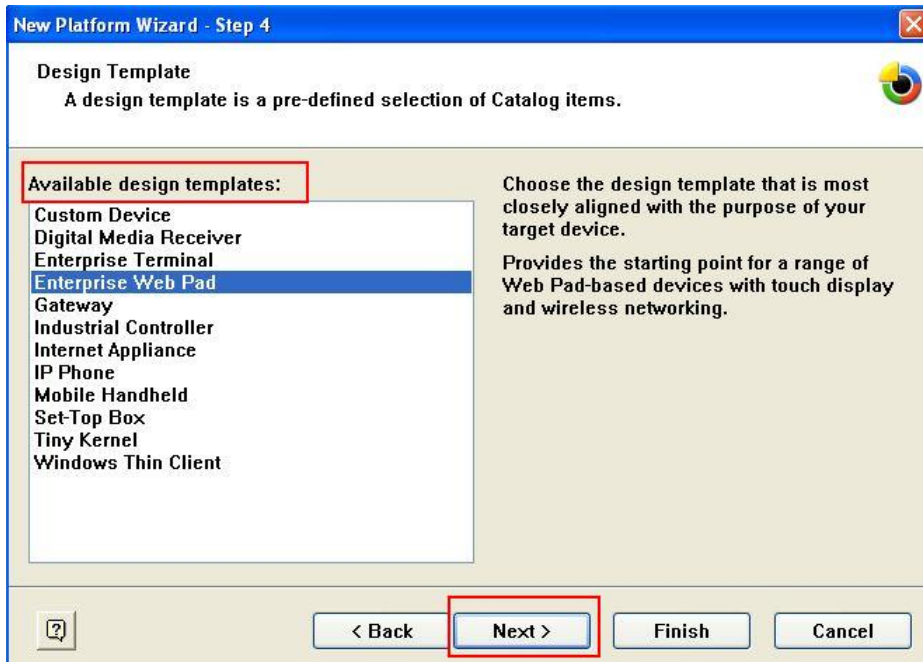

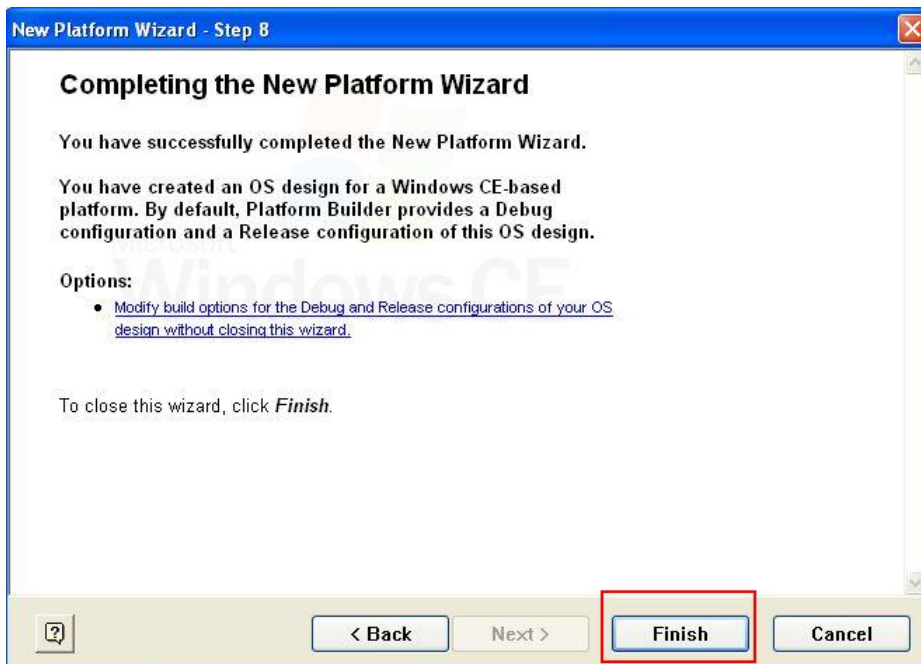
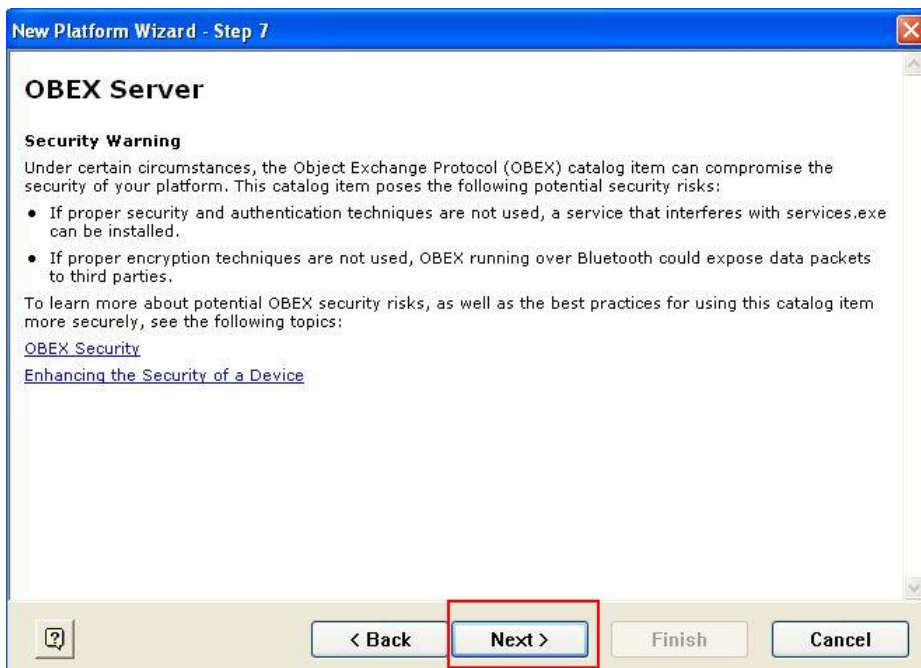
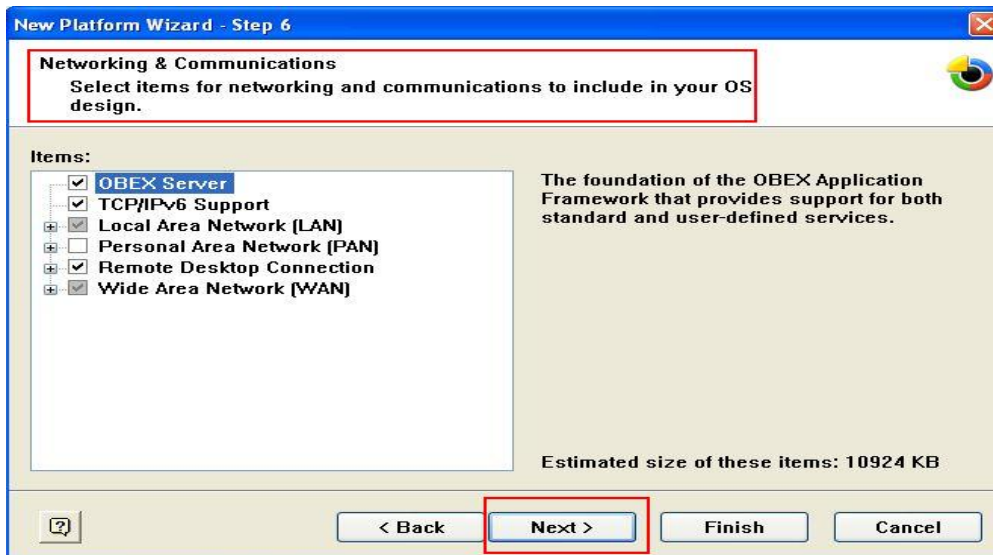

- Open Manage Catalog Items (**File → Manage Catalog Items**). In the **Catalog (View → Catalog)**, browse to **\Third Party\Device Drivers\ MOXA Smartio\Industio-PCI, PC\104-Plus**. Right-click on the driver **Prefix COM** or **Prefix MXU** you would like to include and choose **Add to OS Design**.

**NOTE** You can only select either **Prefix COM** or **Prefix MXU**, but not both.

- Prefix COM supports up to 10 ports, from COM0 to COM9. Prefix MXU supports more than 10 ports, so it is better for you to select Prefix MXU if you are not sure how many ports the device has. Otherwise, you will only be allowed to use one multiport serial board on the target host.

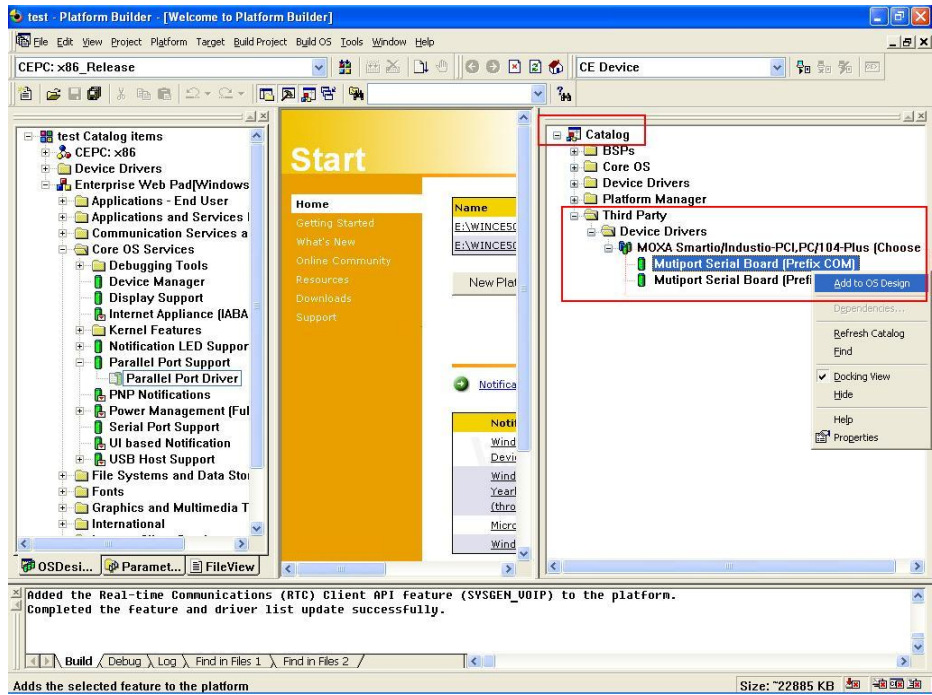

- After adding Moxa Tech drivers into your **OS Design**, a new project is automatically added to your workspace. The project name is **mxserce5**. The project can be accessed from File View (**View → File View**). The **mxserce5** project contains a number of files used to configure the drivers included in your **OS Design**.

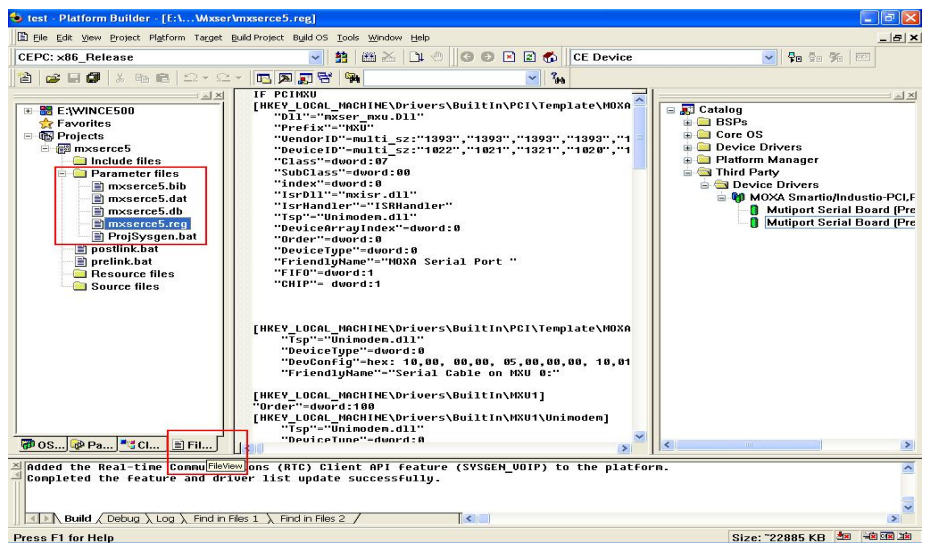

**NOTE** If you would like to use "Terminal Emulator" tool, please modify mxserce5.reg and keyboard like below (This is only just for "one" "COM" port). You have to notice number of ports, COM, MXU and enter the correct information.

```
[HKEY_LOCAL_MACHINE\ExtModems\HayesCompat1]
"Port"="COM2:"
"DeviceType"=dword:1
"FriendlyName"="Hayes Compatible on COM2:"
```

7. Finally, open **Build OS**, select **Build and Sysgen**, and be sure to click **Copy Files to Release Directory After Build** and **Make Run-Time Image After Build**.

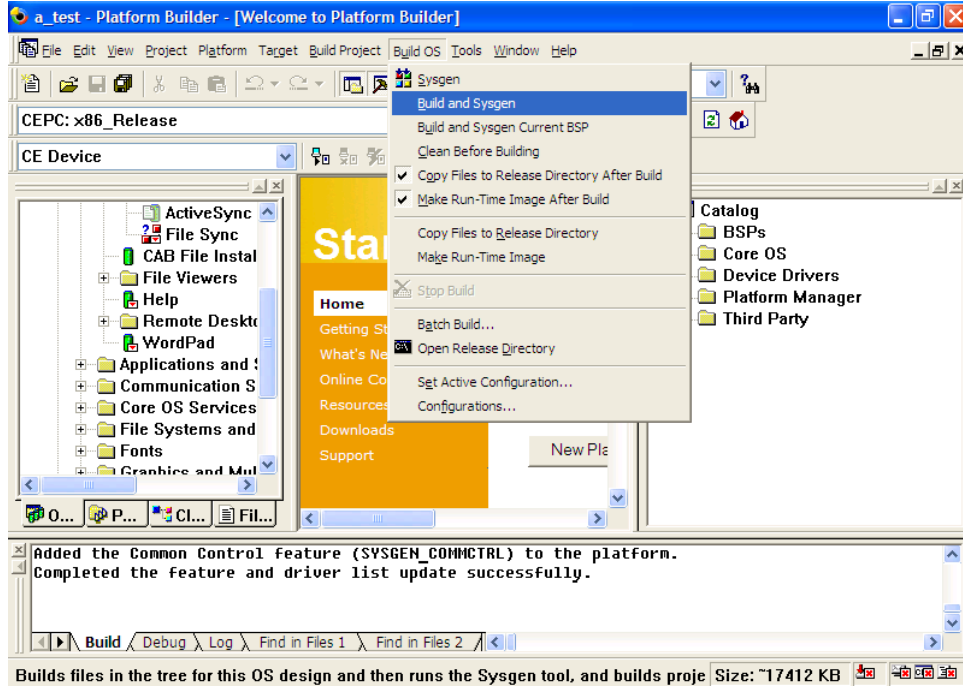

8. Finally, copy your image file to the target Host.

**NOTE** If you have created a Windows CE Platform Builder in the development environment, you can skip steps 2, 3, and 4.

# Windows CE 6.0 Installation

The following procedure explains how to install the CP-102U multiport serial board driver under WinCE 6.0.

1. Obtain a copy of Moxa’s WinCE 6.0 driver and extract it to your computer. Double click the install package to automatically install **Mxser**.
2. Create a new project in Visual Studio 2005.  
 In Visual Studio 2005, click **File → New → Project** and select **“Platform Builder for CE 6.0.”** Choose **“OS Design”** template and then click **OK**.

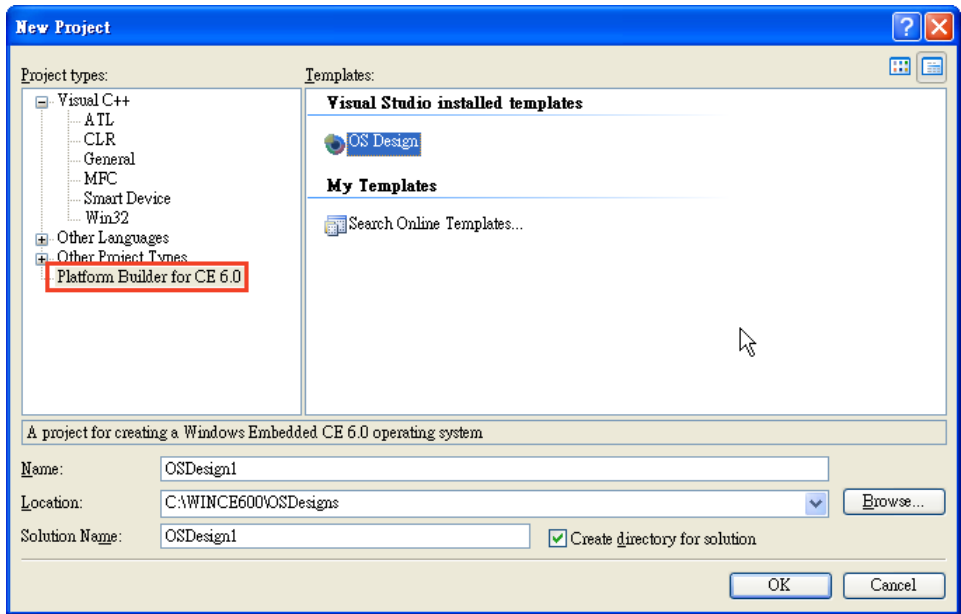
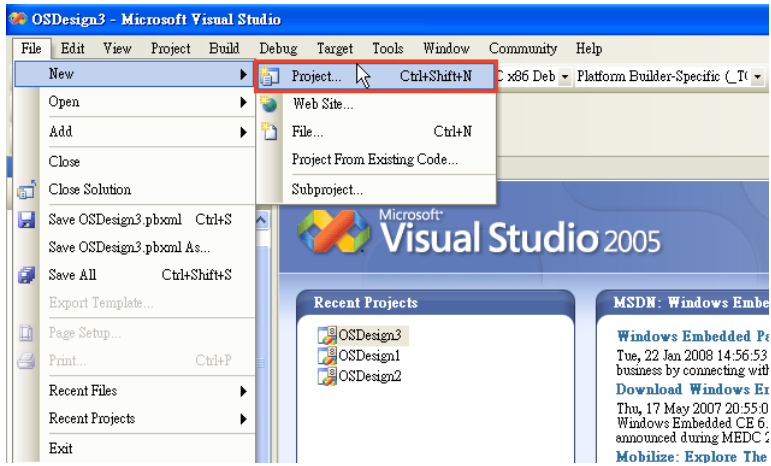



3. The CE 6.0 OS Design Wizard will start. Click "Next" to get the **Board Support Packages** page and select CEPC: **x86**. Click "Next" to continue.

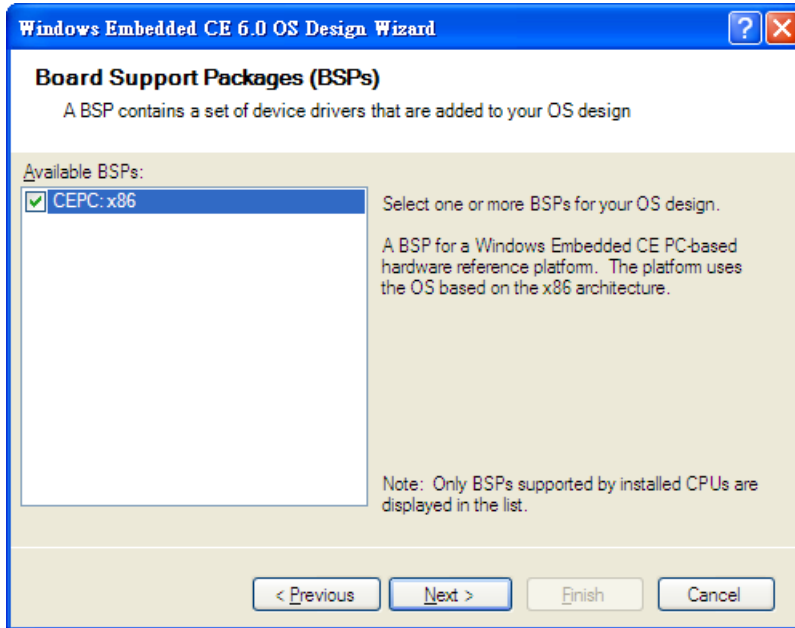



- 4. On the **Design Templates** page select your environment, PDA Device for example. Click **Next** to continue.

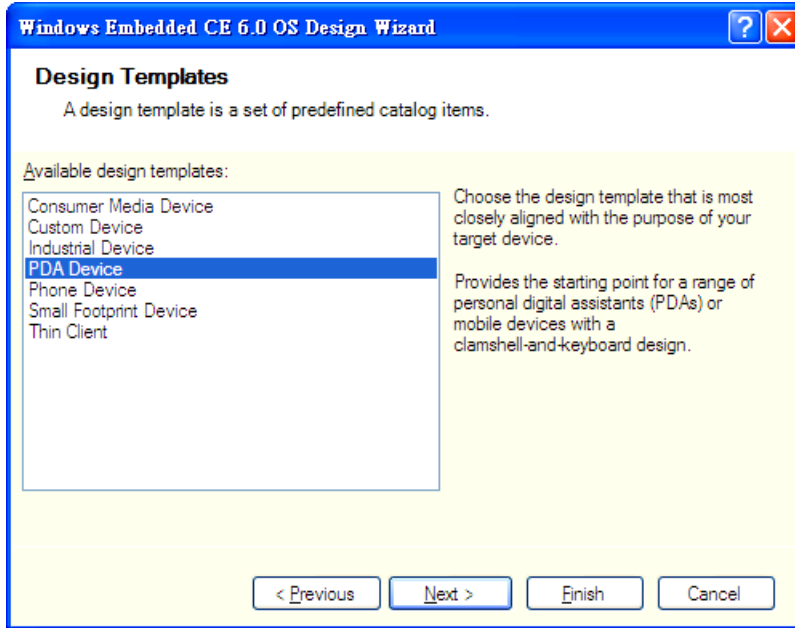

- 5. On the Design Template Variants page select your environment, Mobile Handheld for example. Click **Next** to continue.

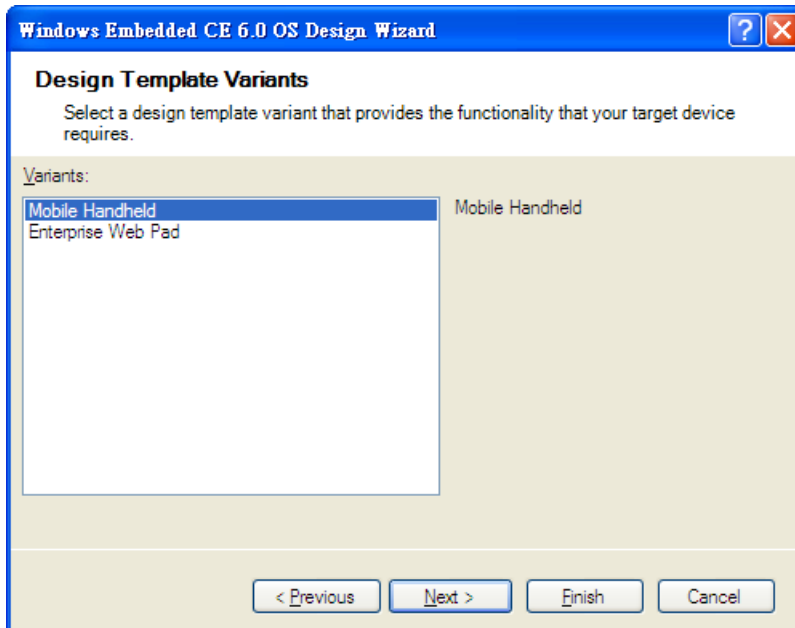

6. On the **Application & Media** page select your environment, .NET Compact Framework 2.0, ActiveSync, and Quarter VGA Resources-Portrait Mode for example. Click **Next** to continue.

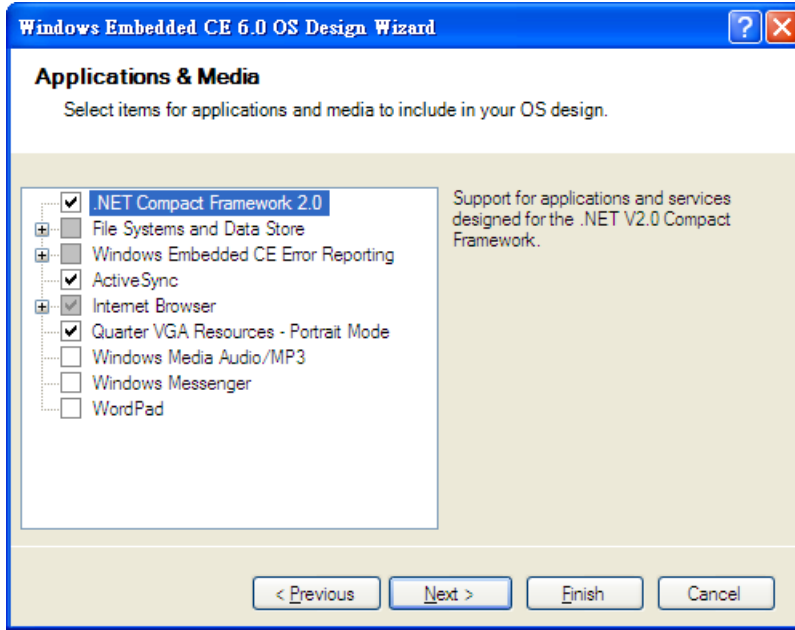

7. On the Networking & Communication page select your environment, TCP/IPv6 Support for example. Click **Next** to continue.

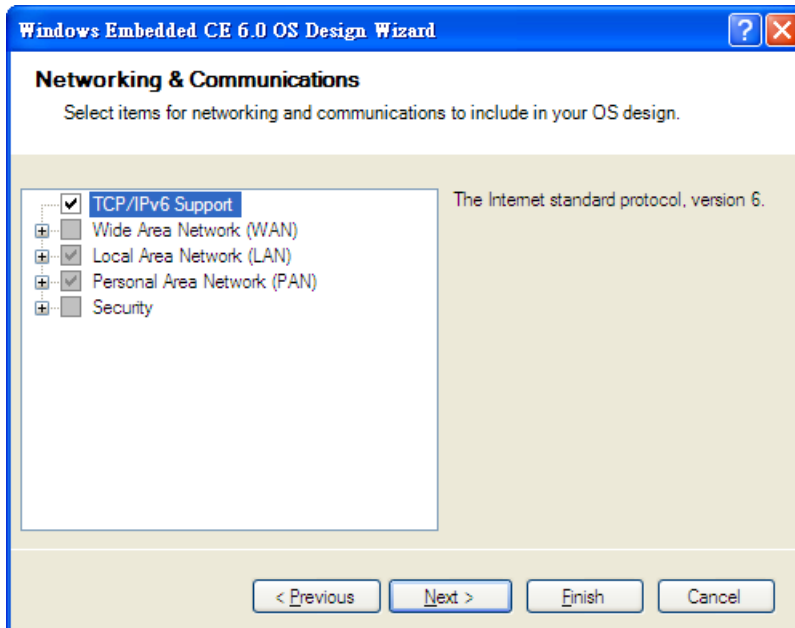

- When the **OS Design Project Wizard Complete** screen appears, click **Finish**. The catalog notification will pop up. Click **Acknowledge** to finish the project.

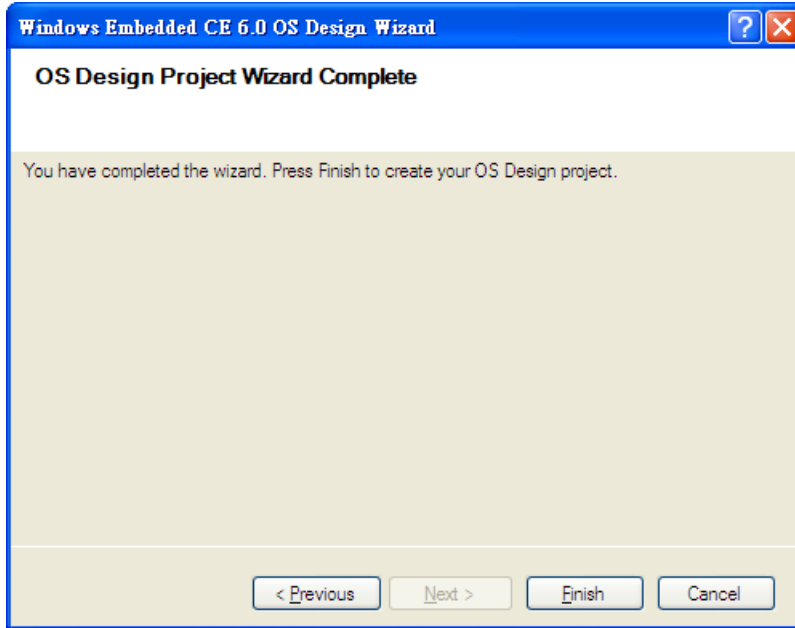

- Open the project you created. Click **Project** on top of the screen, and select **Add Existing Subproject**. Specify the PCI MSB **Mxser** driver location with the subproject file **"mxserce6.pbpxml"**.

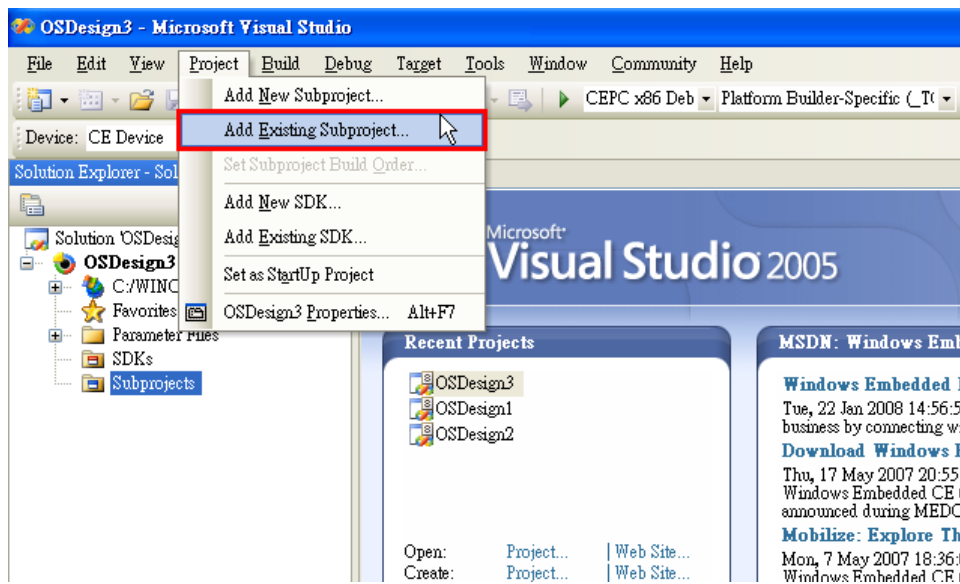

- After the subproject is added, you may configure the **"mxserce6.reg"** registry file with the location [HKEY\_LOCAL\_MACHINE\Drivers\BuiltIn\PCI\Template\MOXAPCI.COM].

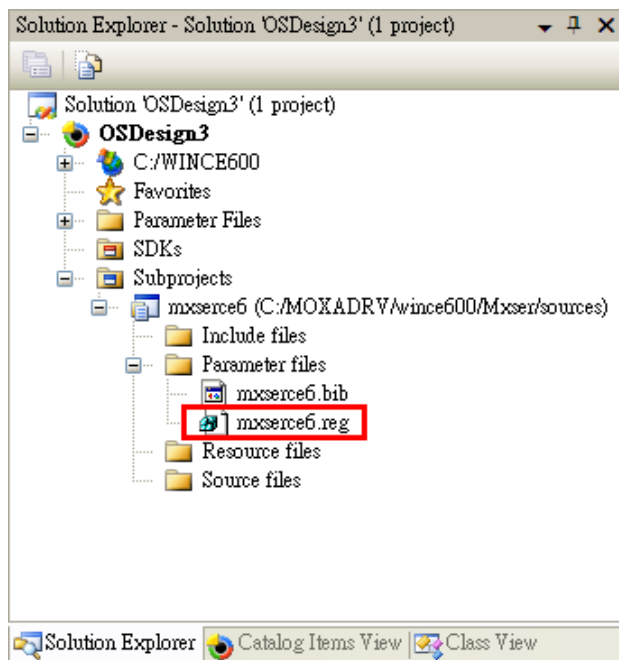

- Configuring FIFO and index: Setting the FIFO registry value to **1** enables the FIFO function and **0** disables it. The index allows you to define the initial COM port number in WinCE, but before using this function; make sure that the COM port numbers do not conflict.

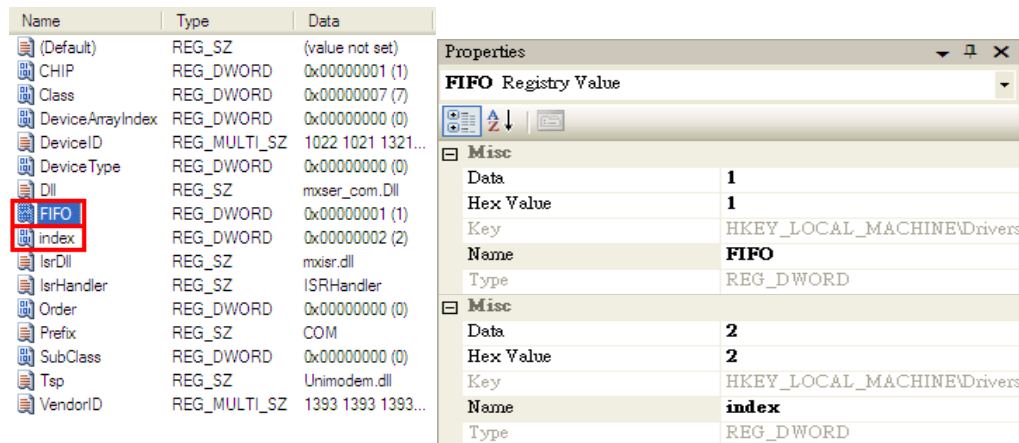

- Open **Build** and select **Advanced Build Commands** and choose **Build Sysgen**. This operation will take you a few minutes.

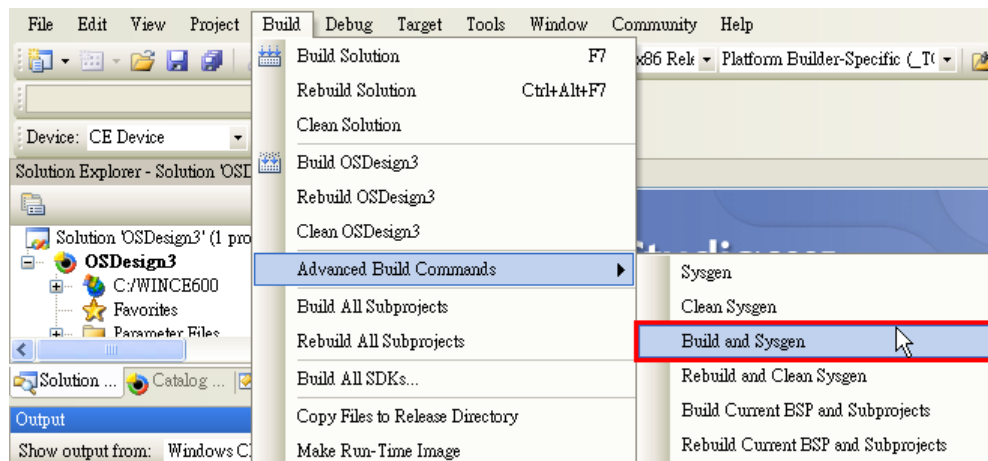

- After building sysgen, select **Build** and choose **Make Run-Time Image** to create the WinCE OS image. Finally, copy your image file to the target Host.

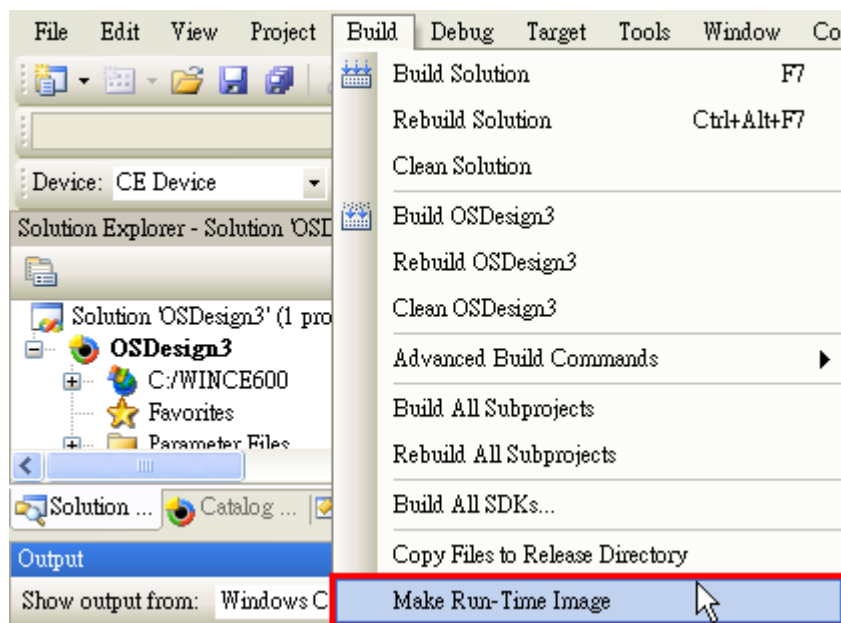

# Driver Installation: Non Windows

---

The following topics are covered in this chapter:

- **Overview**

- **DOS**

- Installing the Driver
- Setting up the Driver
- Loading the Driver
- Unloading the Driver

- **Linux (32-bit/64-bit)**

- **SCO**

# Overview

This chapter explains how to install, configure, update, and remove the board drivers for non Windows operating systems. Before installing the software, be sure to install the hardware first. For details on installing the hardware, please refer to Chapter 2.

You can download DOS, Linux, and SCO drivers from the Moxa website. For information on developing your own serial programming applications, please refer to the next chapter.

# DOS

Moxa DOS API-232 is a software package that can help you develop or debug serial communications programs. This section will show you how to install the package, how to set up the driver, and how to load or unload the driver. The following models are supported:

2 Ports	4 Ports	8 Ports
CP-112UL/ CP-112UL-I	CP-114UL / CP-114UL-I	CP-118U / CP-118U-I
CP-132UL / CP-132UL-I	CP-134U / CP-134U-I	CP-138U / CP-138U-I
CP-102UL	CP-104UL	CP-168U
CP-102U	CP-104JU	
CP-102UF	POS-104UL	

# Installing the Driver

1. Run the installation program, **DOSINST.EXE** under \Software\DOS on the Document & Software CD. Specify the target directory for the API-232 files (e.g., C:\MOXA). Press **F2** to start the installation.



- After installation is complete, you will be prompted to set up the board and driver initial values. It is strongly recommended that you set up the board and driver at this time by pressing **Y**.



## Setting up the Driver

The following instructions are not intended to illustrate every function of the setup program. For more detailed information, please refer to the help files by pressing **F1** in the setup program.

- Run the setup program, **BIN\SETUP.EXE**.  
Select your board model (CP-134U in this example) and press **Enter**.





- Press **PgDn** to view and modify the setup options for the selected board.



- The settings for each port will be displayed. Verify the settings and make any necessary changes.



- Port number:** This is the port ID of each port. Application software will refer to a port by its port number (ID). Port numbers must be unique; duplicate port numbers are not allowed. The port number can range from 0 to 255 as long as it does not overlap with another port. Generally, you should consider the convenience of programming when specifying the port number.
- TxD buffer size:** This is the transmission (output) buffer allocated in the system for each port.
- RxD buffer size:** This is the receiving (input) buffer allocated in the system for each port.
- F5: Group Edit:** This allows you to configure several ports simultaneously as a group.



4. Press **F10** to save the latest configuration and exit the setup program.

## Loading the Driver

After setting up the driver, you must load the driver in order to gain access to the serial ports on the serial board. Run **BIN\DP-DRV.EXE** at the DOS prompt. The driver will detect your multiport serial board automatically. You should see messages indicating successful detection of your module, such as the following:

```
Smartio/Industio Family DOS driver Version 1.9
Setup driver .
CP-134U series (Bus= x ,Dev=y) : OK!
Device driver setup O.K.
```

At this point, you can execute applications that support API-232 functions, or start developing applications using the API-232 library.

## Unloading the Driver

To unload or release the driver from memory, enter **DP-DRV /Q** at the DOS prompt.

# Linux (32-bit/64-bit)

The Linux drivers support the following models:

CP-102U	CP-114UL	CP-132UL-I	CP-138U-I
CP-102UL	CP-118U	CP-134U	CP-168U
CP-104JU	CP-118U-I	CP-134U-I	POS-104UL
CP-104UL	CP-132UL	CP-138U	CP-102UF

To install and load the Linux drivers, enter the following commands from the Linux prompt:

```
# mkdir moxa
# cd moxa
# tar -xzvf driv_linux_smart_vx.x_build_yymmddhh.tgz

# cd mxser
# make clean; make install

# cd /moxa/mxser/driver
# ./msmknod

# modprobe mxser
```

If the driver has loaded successfully, you should see a message such as the following:

```
MOXA Smartio/Industio family driver version 1.11
Found MOXA CP-168U series board(BusNo=2,DevNo=13)
ttyM0 - ttyM7 max. baudrate = 921600 bps
```

You can verify that the driver has loaded by entering the following:

```
# lsmod |grep mxser
```

You should see a message such as the following:

```
mxser 59484 0
```

The installation will include **msdiag**, a diagnostic utility, **mstern**, a terminal emulation program, and **msmon**, a monitoring utility. For additional information, please refer to **readme.txt** in the **/home/moxa/mxser** directory.

## SCO

- **SCO OpenServer 5**
- **SCO OpenServer 6**
- **SCO UnixWare 7**

Follow the steps given in this section to install the SCO OpenServer 5/6 & SCO UnixWare 7 driver. The installation procedures for SCO UnixWare 7 and SCO OpenServer 5/6 are similar.

1. Copy the driver file **.tar** to your host.
2. `#tar xvf <driver tar file>`  
`#/tmp/moxa/mxinstall`
3. The window shown below will open next. Press RETURN to continue.

```
=====
Copyright© 2008 Moxa Inc.
All Rights Reserved.

Moxa Smartio/Industio Family Device Driver Installation (Ver. 1.11)
=====

For SCO UnixWare 7
```

Tar files, please wait.....O.K.  
 Press RETURN to continue

- <Note: If your environment is SCO OpenServer 5/6, you can skip step 4 & 5>  
 When you see the screen below, select "Esc" to exit and reboot your computer.

MOXA Smartio/Industio Family Installation Utility (Ver 1.11)				
Smartio/Industio Family Basic Configuration				
Board No.	Board Type	I/O Address	Interrupt	Bus/Dev No.
1	None	-----	-----	-----
2	None	-----	-----	-----
3	None	-----	-----	-----
4	None	-----	-----	-----
PgDn: getty Setting                      Esc: Exit Enter: Confirm Input Value              Tab: Change Item				

- After rebooting computer, key in "moxaadm", you will see MAIN MENU, select **Basic Configuration**.

MAIN MENU Basic Configuration Advanced Configuration Interface Configuration Port Monitoring Terminal Emulation Driver Removal Exit
--

- When you see the following screen, press Enter to select the MOXA Multiport Serial Board you installed by port and by model. For example, if you installed the CP-104UL, you should select 4 ports and then CP-104UL.

MOXA Smartio/Industio Family Installation Utility (Ver 1.11)				
Smartio/Industio Family Basic Configuration				
Board No.	Board Type	I/O Address	Interrupt	Bus/Dev No.
1	None	-----	-----	-----
2	None	-----	-----	-----
3	None	-----	-----	-----
4	None	-----	-----	-----
PgDn: getty Setting                      Esc: Exit Enter: Confirm Input Value              Tab: Change Item				

- The board's basic information, such as I/O address, Bus No., and Device No., will be shown. The SCO system will assign the resources automatically to the Universal PCI board you selected.
- Next, press "Esc" to exit and reboot your computer.
- Note, whenever you change a MAIN MENU item, you have to reboot your computer.

# 10

## Serial Programming Tools

---

The following topics are covered in this chapter:

- **Overview**
- **Serial Programming Library**
- **PComm Utilities**
  - Installation
  - PComm Diagnostic
  - PComm Monitor
  - PComm Terminal Emulator

## Overview

Moxa provides Windows serial programming libraries and troubleshooting utilities that are easy to use and powerful. You can use these tools to reduce software development time.

The serial communication library is useful for developing applications for data communications, remote access, data acquisition, and industrial control. It provides a simpler solution compared to the more complex Windows Win32 COMM API.

PComm is a professional serial communication tool for Windows PCs. PComm includes the following features:

- Useful utilities for diagnostics, port monitoring, and terminal emulation
- Sample programs
- Comprehensive help files

## Serial Programming Library

The serial programming library assists you in developing serial communications programs for any COM port that complies with the Microsoft Win32 API. It facilitates the implementation of multi-process and multi-thread serial communication programs and can remarkably reduce development time.

The library provides a complete set of functions as well as various sample programs for Visual C++, Visual Basic, and Delphi. To view detailed descriptions of the available functions and sample programs, go to **Start → Program → PComm Lite** and select **PComm Lib Help**, **PComm Porting Notes**, or **PComm Programming Guide**. You may also refer to the sample programs in the PComm directory.

## PComm Utilities

This section provides brief descriptions of the PComm utilities. For more information about these utilities, please refer to the Windows help files or to the API-232.txt file for DOS.

## Installation

To install PComm, run **Setup.exe** from the Document and Software CD. Please note that the PComm diagnostic and monitor utilities are for Moxa boards only. These two utilities will not work with other serial boards.

## PComm Diagnostic

PComm Diagnostic is designed for Moxa boards only. It provides internal and external testing of IRQ, TxD/RxD, UART, CTS/RTS, DTR/DSR, DTR/DCD, and other items. You can use PComm Diagnostic to check the operation of both software and hardware.

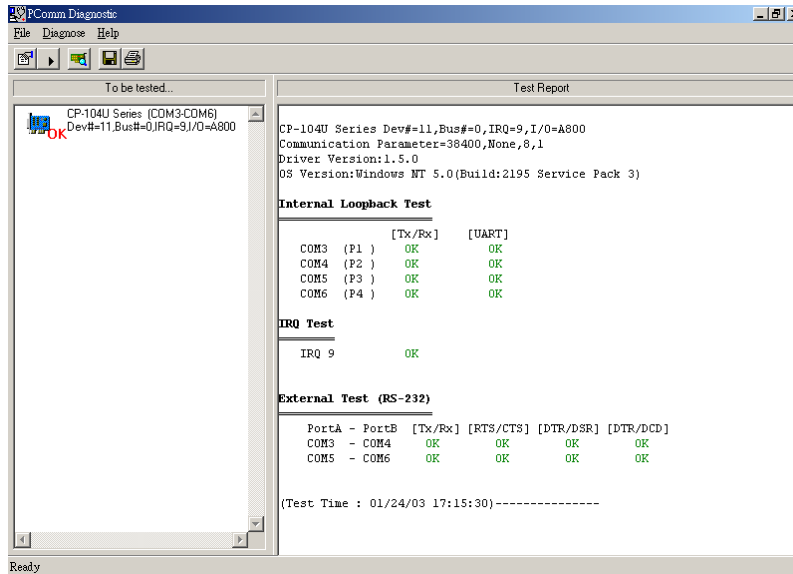

To run the Diagnostic program, go to **Start → Program → PComm Lite → Diagnostic**.

## PComm Monitor

PComm Monitor is designed for Moxa boards in Windows NT only. It allows you to monitor data transmission of selected Moxa COM ports. It monitors data transmission, throughput, and line status at regular intervals. Click on a specific port to view that port's communication parameters and status.

To run PComm Monitor, go to **Start → Program → PComm Lite → Monitor**.

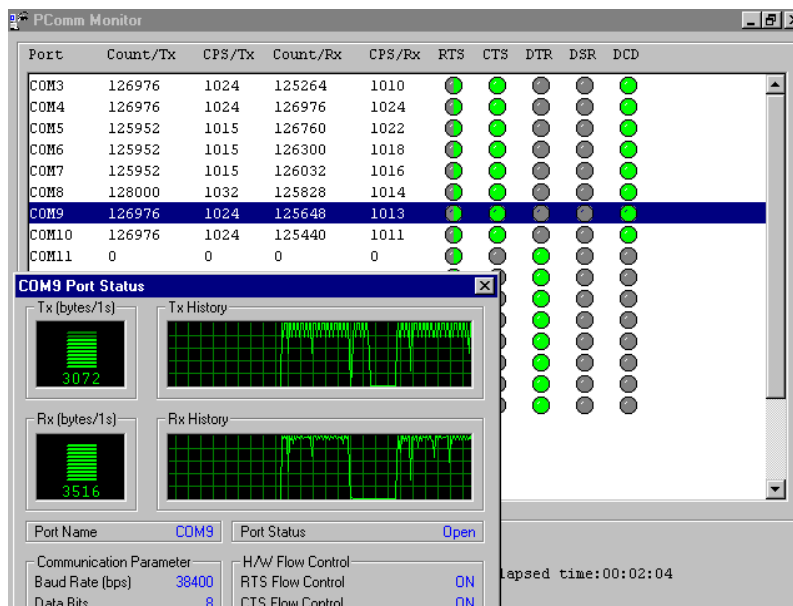

# PComm Terminal Emulator

PComm Terminal Emulator can be used to connect to a serial port to verify that data transmission is functioning correctly. It supports multiple windows and both VT100 and ANSI terminal types. You can interactively transfer data, periodically send patterns, and transfer files using ASCII, XMODEM, YMODEM, ZMODEM, and KERMIT protocols.

To run PComm Terminal Emulator, go to **Start → Program → PComm Lite → Terminal Emulator**.

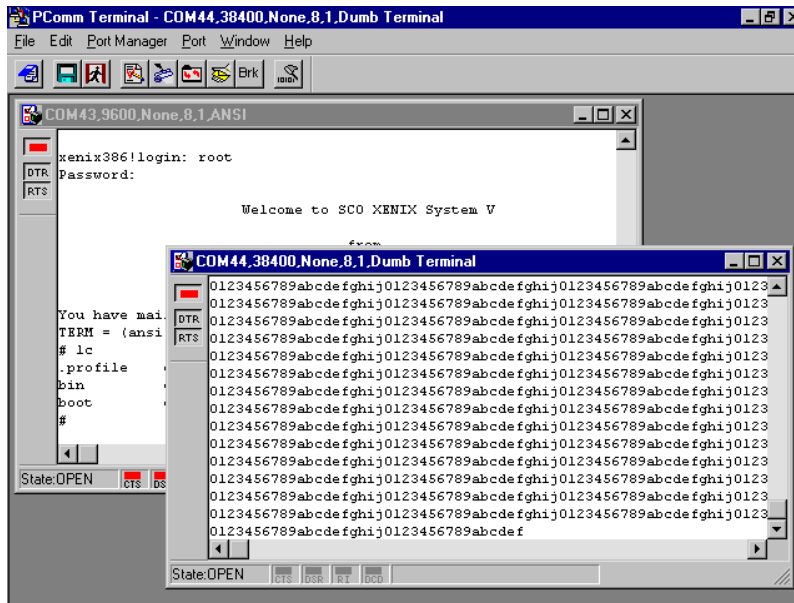



## Pin Assignments

---

The following topics are covered in this chapter:

### □ Overview

#### □ CP-102U

- DB9 (Male): RS-232

#### □ CP-102UL

- DB25 (Female): RS-232

#### □ CP-104JU

- 8-pin RJ45: RS-232

#### □ CP-104UL

- DB44 (Female): RS-232

#### □ CP-112UL

- DB25 (Female): RS-232
- DB25 (Female): RS-422
- DB25 (Female): RS-485 (4-wire)
- DB25 (Female): RS-485 (2-wire)

#### □ CP-114UL

- DB44 (Female): RS-232
- DB44 (Female): RS-422, RS-485 (4-wire)
- DB44 (Female): RS-485 (2-wire)

#### □ CP-118U

- DB62 (Female): RS-232
- DB62 (Female): RS-422, RS-485 (4-wire)
- DB62 (Female): RS-485 (2-wire)

#### □ CP-118U-I

- DB78 (Female): RS-232
- DB78 (Female): RS-422, RS-485 (4-wire)
- DB78 (Female): RS-485 (2-wire)

#### □ CP-132UL, CP-132UL-I

- DB25 (Female): RS-422
- DB25 (Female): RS-485 (4-wire)
- DB25 (Female): RS-485 (2-wire)

#### □ CP-134U, CP-134U-I

- DB44 (Female): RS-232 (Ports 1 and 2 only)
- DB44 (Female): RS-422
- DB44 (Female): RS-485 (4-wire)
- DB44 (Female): RS-485 (2-wire)

#### □ CP-138U

- DB62 (Female): RS-422, RS-485 (4-wire)
- DB62 (Female): RS-485 (2-wire)

#### □ CP-138U-I

- DB78 (Female): RS-422, RS-485 (4-wire)
- DB78 (Female): RS-485 (2-wire)

#### □ CP-168U

- DB62 (Female): RS-232

#### □ POS-104UL

- DB44 (Female): RS-232

#### □ CP-102UF

#### □ Serial Connectors

- DB9 (Male)
- DB25 (Male)
- DB25 (Female)
- RJ45

# Overview

This chapter provides the pin assignments for each Moxa UPCI multiport serial board, as well as the pin assignments for the optional accessories. Except for the CP-102U and CP-102UF, which have two built-in DB9 (male) serial connectors and an ST type fiber connector, respectively, Moxa's UPCI boards do not have built-in serial port connectors. For all other models, you will need a cable or other accessory with standard serial connectors in order to connect serial devices to the board. The following chart shows the available cables and accessories for each model.

Model	Board Connector	Supported Accessories	Serial Connectors
CP-102U	2×DB9 (male)	---	---
CP-102UL CP-112UL CP-112UL-I CP-132UL CP-132UL-I	DB25 (female)	CBL-M25M9x2-50	2×DB9 (male)
CP-104UL CP-114UL CP-114UL-I CP-134U CP-134U-I	DB44 (female)	CBL-M44M9x4-50 CBL-M44M25x4-50	4×DB9 (male) 4×DB25 (male)
CP-104JU	RJ45	CBL-RJ45M9-150 CBL-RJ45M25-150	4×DB9 (male) 4×DB25 (male)
CP-118U CP-138U CP-168U	DB62 (female)	OPT8-M9 CBL-M62M9x8-100 (OPT8D) OPT8B CBL-M62M25x8-100 (OPT8C) OPT8A, OPT8S, OPT8F, OPT8Z, OPT8K, OPT8I OPT8-RJ45*	8×DB9 (male) 8×DB25 (male) 8×DB25 (female) 8×RJ45
CP-118U-I CP-138U-I	DB78 (female)	CBL-M78M9x8-100 CBL-M78M25x8-100	8×DB9 (male) 8×DB25 (male)
POS-104UL	DB44 (female)	CBL-M44M9x4-50(POS)	4×DB9 (male)
CP-102UF	STx2	---	---

\* The OPT8-RJ45 is designed for RS-232 only. It should only be used with the CP-118U in RS-232 mode or with the CP-168U.

The serial connectors on each accessory use standard serial port pin assignments. Please refer to the Serial Connectors section for details.

## CP-102U

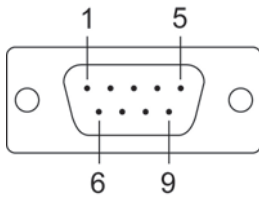

This board supports RS-232 only.

Model	Board Connector	Supported Accessories	Serial Connectors
CP-102U	2×DB9 (male)	---	---

### DB9 (Male): RS-232

Pin	Signal
1	DCD
2	RxD
3	TxD
4	DTR
5	GND
6	DSR
7	RTS
8	CTS

## CP-102UL

This board supports RS-232 only.

Model	Board Connector	Supported Accessories	Serial Connectors
CP-102UL	DB25 (female)	CBL-M25M9x2-50	2×DB9 (male)

### DB25 (Female): RS-232

Pin	Signal	Pin	Signal
1	---	14	---
2	DCD1	15	DTR1
3	GND	16	DSR1
4	CTS1	17	RTS1
5	RxD1	18	TxD1
6	---	19	---
7	---	20	---
8	---	21	DCD0
9	DTR0	22	GND
10	DSR0	23	CTS0
11	RTS0	24	RxD0
12	TxD0	25	---
13	---	---	---

# CP-104JU

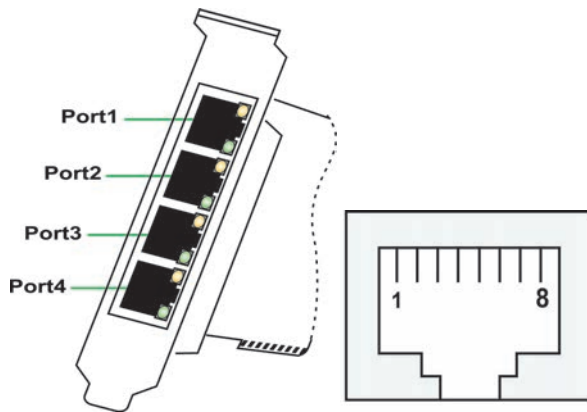

This board supports RS-232 only.

Model	Board Connector	Supported Accessories	Serial Connectors
CP-104JU	RJ45	CBL-RJ45M9-150	4×DB9 (male)
		CBL-RJ45M25-150	4×DB25 (male)

## 8-pin RJ45: RS-232

Pin	Signal
1	DSR
2	RTS
3	GND
4	TxD
5	RxD
6	DCD
7	CTS
8	DTR

# CP-104UL

This board supports RS-232 only.

Model	Board Connector	Supported Accessories	Serial Connectors
CP-104UL	DB44 (female)	CBL-M44M9x4-50	4×DB9 (male)
		CBL-M44M25x4-50	4×DB25 (male)

## DB44 (Female): RS-232

Pin	Signal	Pin	Signal	Pin	Signal
1	TxD3	16	CTS3	31	DCD3
2	RxD3	17	DTR3	32	---
3	RTS3	18	DSR3	33	GND
4	---	19	---	34	---
5	TxD2	20	CTS2	35	DCD2
6	RxD2	21	DTR2	36	---
7	RTS2	22	DSR2	37	GND
8	---	23	---	38	---
9	TxD1	24	CTS1	39	DCD1
10	RxD1	25	DTR1	40	---
11	RTS1	26	DSR1	41	GND
12	---	27	---	42	DCD0
13	TxD0	28	CTS0	43	---
14	RxD0	29	DTR0	44	GND
15	RTS0	30	DSR0	---	---

# CP-112UL

This board supports RS-232, RS-422, and RS-485 (both 2 and 4-wire).

Model	Board Connector	Supported Accessories	Serial Connectors
CP-112UL	DB25 (female)	CBL-M25M9x2-50	2×DB9 (male)

## DB25 (Female): RS-232

Pin	Signal	Pin	Signal
1	---	14	---
2	DCD1	15	DTR1
3	GND	16	DSR1
4	CTS1	17	RTS1
5	RxD1	18	TxD1
6	---	19	---
7	---	20	---
8	---	21	DCD0
9	DTR0	22	GND
10	DSR0	23	CTS0
11	RTS0	24	RxD0
12	TxD0	25	---
13	---	---	---

### DB25 (Female): RS-422

Pin	Signal	Pin	Signal
1	---	14	---
2	TxD1-(A)	15	RxD1-(A)
3	GND1	16	---
4	---	17	---
5	TxD1+(B)	18	RxD1+(B)
6	---	19	---
7	---	20	---
8	---	21	TxD0-(A)
9	RxD0-(A)	22	GND0
10	---	23	---
11	---	24	TxD0+(B)
12	RxD0+(B)	25	---
13	---	---	---

### DB25 (Female): RS-485 (4-wire)

Pin	Signal	Pin	Signal
1	---	14	---
2	TxD1-(A)	15	RxD1-(A)
3	GND1	16	---
4	---	17	---
5	TxD1+(B)	18	RxD1+(B)
6	---	19	---
7	---	20	---
8	---	21	TxD0-(A)
9	RxD0-(A)	22	GND0
10	---	23	---
11	---	24	TxD0+(B)
12	RxD0+(B)	25	---
13	---	---	---

### DB25 (Female): RS-485 (2-wire)

Pin	Signal	Pin	Signal
1	---	14	---
2	---	15	Data1-(A)
3	GND1	16	---
4	---	17	---
5	---	18	Data1+(B)
6	---	19	---
7	---	20	---
8	---	21	---
9	Data0-(A)	22	GND0
10	---	23	---
11	---	24	---
12	Data0+(B)	25	---
13	---	---	---

# CP-114UL

This board supports RS-232, RS-422, and RS-485 (both 2 and 4-wire).

Model	Board Connector	Supported Accessories	Serial Connectors
CP-114UL	DB44 (female)	CBL-M44M9x4-50	4×DB9 (male)
		CBL-M44M25x4-50	4×DB25 (male)

## DB44 (Female): RS-232

Pin	Signal	Pin	Signal	Pin	Signal
1	TxD3	16	CTS3	31	DCD3
2	RxD3	17	DTR3	32	---
3	RTS3	18	DSR3	33	GND
4	---	19	---	34	---
5	TxD2	20	CTS2	35	DCD2
6	RxD2	21	DTR2	36	---
7	RTS2	22	DSR2	37	GND
8	---	23	---	38	---
9	TxD1	24	CTS1	39	DCD1
10	RxD1	25	DTR1	40	---
11	RTS1	26	DSR1	41	GND
12	---	27	---	42	DCD0
13	TxD0	28	CTS0	43	---
14	RxD0	29	DTR0	44	GND
15	RTS0	30	DSR0	---	---

## DB44 (Female): RS-422, RS-485 (4-wire)

Pin	Signal	Pin	Signal	Pin	Signal
1	RxD3+(B)	16	---	31	TxD3-(A)
2	TxD3+(B)	17	RxD3-(A)	32	---
3	---	18	---	33	GND
4	---	19	---	34	---
5	RxD2+(B)	20	---	35	TxD2-(A)
6	TxD2+(B)	21	RxD2-(A)	36	---
7	---	22	---	37	GND
8	---	23	---	38	---
9	RxD1+(B)	24	---	39	TxD1-(A)
10	TxD1+(B)	25	RxD1-(A)	40	---
11	---	26	---	41	GND
12	---	27	---	42	TxD0-(A)
13	RxD0+(B)	28	---	43	---
14	RxD0-(A)	29	RxD0-(A)	44	GND
15	---	30	---	---	---

### DB44 (Female): RS-485 (2-wire)

Pin	Signal	Pin	Signal	Pin	Signal
1	Data3+(B)	16	---	31	---
2	---	17	Data3-(A)	32	---
3	---	18	---	33	GND
4	---	19	---	34	---
5	Data2+(B)	20	---	35	---
6	---	21	Data2-(A)	36	---
7	---	22	---	37	GND
8	---	23	---	38	---
9	Data1+(B)	24	---	39	---
10	---	25	Data1-(A)	40	---
11	---	26	---	41	GND
12	---	27	---	42	---
13	Data0+(B)	28	---	43	---
14	---	29	Data0-(A)	44	GND
15	---	30	---	---	---

### CP-118U

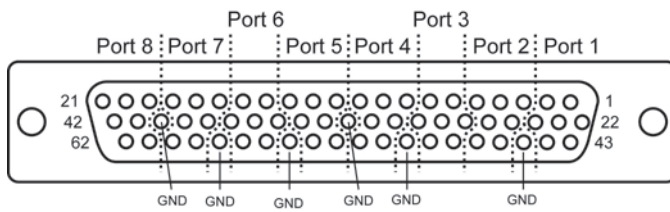

This board supports RS-232, RS-422, and RS-485 (both 2 and 4-wire).

Model	Board Connector	Supported Accessories	Serial Connectors
CP-118U	DB62 (female)	OPT8-M9 CBL-M62M9x8-100 (OPT8D)	8×DB9 (male)
		OPT8B CBL-M62M25x8-100 (OPT8C)	8×DB25 (male)
		OPT8A, OPT8S	8×DB25 (female)
		OPT8-RJ45*	8×RJ45

\* The OPT8-RJ45 is designed for RS-232 only. It should only be used with the CP-118U in RS-232 mode.



**DB62 (Female): RS-232**

Pin	Signal	Pin	Signal	Pin	Signal
1	TxD0	22	RxD0	43	CTS0
2	DTR0	23	DSR0	44	RTS0
3	RxD1	24	DCD0	45	GND
4	DSR1	25	TxD1	46	CTS1
5	DCD1	26	DTR1	47	RTS1
6	TxD2	27	RxD2	48	CTS2
7	DTR2	28	DSR2	49	RTS2
8	RxD3	29	DCD2	50	GND
9	DSR3	30	TxD3	51	CTS3
10	DCD3	31	DTR3	52	RTS3
11	RxD4	32	GND	53	CTS4
12	DSR4	33	TxD4	54	RTS4
13	DCD4	34	DTR4	55	GND
14	TxD5	35	RxD5	56	CTS5
15	DTR5	36	DSR5	57	RTS5
16	RxD6	37	DCD5	58	GND
17	DSR6	38	TxD6	59	CTS6
18	DCD6	39	DTR6	60	RTS6
19	RxD7	40	GND	61	CTS7
20	DSR7	41	TxD7	62	RTS7
21	DCD7	42	DTR7	---	---

**DB62 (Female): RS-422, RS-485 (4-wire)**

Pin	Signal	Pin	Signal	Pin	Signal
1	RxD0+(B)	22	TxD0+(B)	43	---
2	RxD0-(A)	23	---	44	---
3	TxD1+(B)	24	TxD0-(A)	45	GND
4	---	25	RxD1+(B)	46	---
5	TxD1-(A)	26	RxD1-(A)	47	---
6	RxD2+(B)	27	TxD2+(B)	48	---
7	RxD2-(A)	28	---	49	---
8	TxD3+(B)	29	TxD2-(A)	50	GND
9	---	30	RxD3+(B)	51	---
10	TxD3-(A)	31	RxD3-(A)	52	---
11	TxD4+(B)	32	GND	53	---
12	---	33	RxD4+(B)	54	---
13	TxD4-(A)	34	RxD4-(A)	55	GND
14	RxD5+(B)	35	TxD5+(B)	56	---
15	RxD5-(A)	36	---	57	---
16	TxD6+(B)	37	TxD5-(A)	58	GND
17	---	38	RxD6+(B)	59	---
18	TxD6-(A)	39	RxD6-(A)	60	---
19	TxD7+(B)	40	GND	61	---
20	---	41	RxD7+(B)	62	---
21	TxD7-(A)	42	RxD7-(A)	---	---

### DB62 (Female): RS-485 (2-wire)

Pin	Signal	Pin	Signal	Pin	Signal
1	Data0+(B)	22	---	43	---
2	Data0-(A)	23	---	44	---
3	---	24	---	45	GND
4	---	25	Data1+(B)	46	---
5	---	26	Data1-(A)	47	---
6	Data2+(B)	27	---	48	---
7	Data2-(A)	28	---	49	---
8	---	29	---	50	GND
9	---	30	Data3+(B)	51	---
10	---	31	Data3-(A)	52	---
11	---	32	GND	53	---
12	---	33	Data4+(B)	54	---
13	---	34	Data4-(A)	55	GND
14	Data5+(B)	35	---	56	---
15	Data5-(A)	36	---	57	---
16	---	37	---	58	GND
17	---	38	Data6+(B)	59	---
18	---	39	Data6-(A)	60	---
19	---	40	GND	61	---
20	---	41	Data7+(B)	62	---
21	---	42	Data7-(A)	---	---

## CP-118U-I

This board supports RS-232, RS-422, and RS-485 (both 2 and 4-wire).

Model	Board Connector	Supported Accessories	Serial Connectors
CP-118U-I	DB78 (female)	CBL-M78M9x8-100	8×DB9 (male)
		CBL-M78M25x8-100	8×DB25 (male)

### DB78 (Female): RS-232

Pin	Signal	Pin	Signal	Pin	Signal
1	GND7	27	DTR5	53	CTS2
2	TxD7	28	RTS4	54	DSR2
3	---	29	DTR4	55	CTS1
4	GND6	30	---	56	DSR1
5	TxD6	31	RTS3	57	---
6	GND5	32	DTR3	58	CTS0
7	TxD5	33	RTS2	59	DSR0
8	---	34	DTR2	60	DCD7
9	GND4	35	---	61	RxD7
10	TxD4	36	RTS1	62	DCD6
11	GND3	37	DTR1	63	RxD6
12	TxD3	38	RTS0	64	---
13	---	39	DTR0	65	DCD5
14	GND2	40	CTS7	66	RxD5
15	TxD2	41	DSR7	67	DCD4
16	GND1	42	---	68	RxD4
17	TxD1	43	CTS6	69	---
18	---	44	DSR6	70	DCD3
19	GND0	45	CTS5	71	RxD3
20	TxD0	46	DSR5	72	DCD2
21	RTS7	47	---	73	RxD2
22	DTR7	48	CTS4	74	---
23	RTS6	49	DSR4	75	DCD1
24	DTR6	50	CTS3	76	RxD1
25	---	51	DSR3	77	DCD0
26	RTS5	52	---	78	RxD0

### DB78 (Female): RS-422, RS-485 (4-wire)

Pin	Signal	Pin	Signal	Pin	Signal
1	GND7	27	RxD5-(A)	53	---
2	RxD7+(B)	28	---	54	---
3	---	29	RxD4-(A)	55	---
4	GND6	30	---	56	---
5	RxD6+(B)	31	---	57	---
6	GND5	32	RxD3-(A)	58	---
7	RxD5+(B)	33	---	59	---
8	---	34	RxD2-(A)	60	TxD7-(A)
9	GND4	35	---	61	TxD7+(B)
10	RxD4+(B)	36	---	62	TxD6-(A)
11	GND3	37	RxD1-(A)	63	TxD6+(B)
12	RxD3+(B)	38	---	64	---
13	---	39	RxD0-(A)	65	TxD5-(A)
14	GND2	40	---	66	TxD5+(B)
15	RxD2+(B)	41	---	67	TxD4-(A)
16	GND1	42	---	68	TxD4+(B)
17	RxD1+(B)	43	---	69	---
18	---	44	---	70	TxD3-(A)
19	GND0	45	---	71	TxD3+(B)
20	RxD0+(B)	46	---	72	TxD2-(A)
21	---	47	---	73	TxD2+(B)
22	RxD7-(A)	48	---	74	---
23	---	49	---	75	TxD1-(A)
24	RxD6-(A)	50	---	76	TxD1+(B)
25	---	51	---	77	TxD0-(A)
26	---	52	---	78	TxD0+(B)

### DB78 (Female): RS-485 (2-wire)

Pin	Signal	Pin	Signal	Pin	Signal
1	GND7	15	Data2+(B)	29	Data4-(A)
2	Data7+(B)	16	GND1	30	---
3	---	17	Data1+(B)	31	---
4	GND6	18	---	32	Data3-(A)
5	Data6+(B)	19	GND0	33	---
6	GND5	20	Data0+(B)	34	Data2-(A)
7	Data5+(B)	21	---	35	---
8	---	22	Data7-(A)	36	---
9	GND4	23	---	37	Data1-(A)
10	Data4+(B)	24	Data6-(A)	38	---
11	GND3	25	---	39	Data0-(A)
12	Data3+(B)	26	---	40	---
13	---	27	Data5-(A)	41	---
14	GND2	28	---	42	---

## CP-132UL, CP-132UL-I

These boards support RS-422 and RS-485 (both 2 and 4-wire).

Model	Board Connector	Supported Accessories	Serial Connectors
CP-132UL CP-132UL-I	DB25 (female)	CBL-M25M9x2-50	2×DB9 (male)

### DB25 (Female): RS-422

Pin	Signal	Pin	Signal
1	---	14	CTS1-(A)
2	TxD1-(A)	15	RxD1-(A)
3	GND1	16	RTS1-(A)
4	CTS1+(B)	17	RTS1+(B)
5	TxD1+(B)	18	RxD1+(B)
6	---	19	---
7	---	20	---
8	CTS0-(A)	21	TxD0-(A)
9	RxD0-(A)	22	GND0
10	RTS0-(A)	23	CTS0+(B)
11	RTS0+(B)	24	TxD0+(B)
12	RxD0+(B)	25	---
13	---	---	---

### DB25 (Female): RS-485 (4-wire)

Pin	Signal	Pin	Signal
1	---	14	---
2	TxD1-(A)	15	RxD1-(A)
3	GND1	16	---
4	---	17	---
5	TxD1+(B)	18	RxD1+(B)
6	---	19	---
7	---	20	---
8	---	21	TxD0-(A)
9	RxD0-(A)	22	GND0
10	---	23	---
11	---	24	TxD0+(B)
12	RxD0+(B)	25	---
13	---	---	---

### DB25 (Female): RS-485 (2-wire)

Pin	Signal	Pin	Signal
1	---	14	---
2	---	15	Data1-(A)
3	GND1	16	---
4	---	17	---
5	---	18	Data1+(B)
6	---	19	---
7	---	20	---
8	---	21	---
9	Data0-(A)	22	GND0
10	---	23	---
11	---	24	---
12	Data0+(B)	25	---
13	---	---	---

### CP-134U, CP-134U-I

These boards support RS-422 and RS-485 (both 2 and 4-wire). Ports 1 and 2 also support RS-232.

Model	Board Connector	Supported Accessories	Serial Connectors
CP-134U	DB44 (female)	CBL-M44M9x4-50	4×DB9 (male)
CP-134U-I		CBL-M44M25x4-50	4×DB25 (male)

### DB44 (Female): RS-232 (Ports 1 and 2 only)

Pin	Signal	Pin	Signal	Pin	Signal
1	---	16	---	31	---
2	---	17	---	32	---
3	---	18	---	33	---
4	---	19	---	34	---
5	---	20	---	35	---
6	---	21	---	36	---
7	---	22	---	37	---
8	---	23	---	38	---
9	TXD1	24	CTS1	39	DCD1
10	RXD1	25	DTR1	40	RI1
11	RTS1	26	DSR1	41	GND
12	---	27	---	42	DCD0
13	TXD0	28	CTS0	43	RI0
14	RXD0	29	DTR0	44	GND
15	RTS0	30	DSR0	---	---

### DB44 (Female): RS-422

Pin	Signal	Pin	Signal	Pin	Signal
1	RXD3+(B)	16	CTS3+(B)	31	TXD3-(A)
2	TXD3+(B)	17	RXD3-(A)	32	CTS3-(A)
3	RTS3+(B)	18	RTS3-(A)	33	GND3
4	---	19	---	34	---
5	RXD2+(B)	20	CTS2+(B)	35	TXD2-(A)
6	TXD2+(B)	21	RXD2-(A)	36	CTS2-(A)
7	RTS2+(B)	22	RTS2-(A)	37	GND2
8	---	23	---	38	---
9	RXD1+(B)	24	CTS1+(B)	39	TXD1-(A)
10	TXD1+(B)	25	RXD1-(A)	40	CTS1-(A)
11	RTS1+(B)	26	RTS1-(A)	41	GND1
12	---	27	---	42	TXD0-(A)
13	RXD0+(B)	28	CTS0+(B)	43	CTS0-(A)
14	TXD0+(B)	29	RXD0-(A)	44	GND0
15	RTS0+(B)	30	RTS0-(A)	---	---

### DB44 (Female): RS-485 (4-wire)

Pin	Signal	Pin	Signal	Pin	Signal
1	RXD3+(B)	16	---	31	TXD3-(A)
2	TXD3+(B)	17	RXD3-(A)	32	---
3	---	18	---	33	GND3
4	---	19	---	34	---
5	RXD2+(B)	20	---	35	TXD2-(A)
6	TXD2+(B)	21	RXD2-(A)	36	---
7	---	22	---	37	GND2
8	---	23	---	38	---
9	RXD1+(B)	24	---	39	TXD1-(A)
10	TXD1+(B)	25	RXD1-(A)	40	---
11	---	26	---	41	GND1
12	---	27	---	42	TXD0-(A)
13	RXD0+(B)	28	---	43	---
14	TXD0+(B)	29	RXD0-(A)	44	GND0
15	---	30	---	---	---

## DB44 (Female): RS-485 (2-wire)

Pin	Signal	Pin	Signal	Pin	Signal
1	Data3+(B)	16	---	31	---
2	---	17	Data3-(A)	32	---
3	---	18	---	33	GND3
4	---	19	---	34	---
5	Data2+(B)	20	---	35	---
6	---	21	Data2-(A)	36	---
7	---	22	---	37	GND2
8	---	23	---	38	---
9	Data1+(B)	24	---	39	---
10	---	25	Data1-(A)	40	---
11	---	26	---	41	GND1
12	---	27	---	42	---
13	Data0+(B)	28	---	43	---
14	---	29	Data0-(A)	44	GND0
15	---	30	---	---	---

## CP-138U

This board supports RS-422 and RS-485 (both 2 and 4-wire).

Model	Board Connector	Supported Accessories	Serial Connectors
CP-138U	DB62 (female)	OPT8-M9 CBL-M62M9x8-100 (OPT8D)	8×DB9 (male)
		OPT8B CBL-M62M25x8-100 (OPT8C)	8×DB25 (male)
		OPT8A, OPT8S, OPT8F, OPT8Z, OPT8K, OPT8I	8×DB25 (female)



### DB62 (Female): RS-422, RS-485 (4-wire)

Pin	Signal	Pin	Signal	Pin	Signal
1	RxD0+(B)	22	TxD0+(B)	43	---
2	RxD0-(A)	23	---	44	---
3	TxD1+(B)	24	TxD0-(A)	45	GND
4	---	25	RxD1+(B)	46	---
5	TxD1-(A)	26	RxD1-(A)	47	---
6	RxD2+(B)	27	TxD2+(B)	48	---
7	RxD2-(A)	28	---	49	---
8	TxD3+(B)	29	TxD2-(A)	50	GND
9	---	30	RxD3+(B)	51	---
10	TxD3-(A)	31	RxD3-(A)	52	---
11	TxD4+(B)	32	GND	53	---
12	---	33	RxD4+(B)	54	---
13	TxD4-(A)	34	RxD4-(A)	55	GND
14	RxD5+(B)	35	TxD5+(B)	56	---
15	RxD5-(A)	36	---	57	---
16	TxD6+(B)	37	TxD5-(A)	58	GND
17	---	38	RxD6+(B)	59	---
18	TxD6-(A)	39	RxD6-(A)	60	---
19	TxD7+(B)	40	GND	61	---
20	---	41	RxD7+(B)	62	---
21	TxD7-(A)	42	RxD7-(A)	---	---

### DB62 (Female): RS-485 (2-wire)

Pin	Signal	Pin	Signal	Pin	Signal
1	Data0+(B)	22	---	43	---
2	Data0-(A)	23	---	44	---
3	---	24	---	45	GND
4	---	25	Data1+(B)	46	---
5	---	26	Data1-(A)	47	---
6	Data2+(B)	27	---	48	---
7	Data2-(A)	28	---	49	---
8	---	29	---	50	GND
9	---	30	Data3+(B)	51	---
10	---	31	Data3-(A)	52	---
11	---	32	GND	53	---
12	---	33	Data4+(B)	54	---
13	---	34	Data4-(A)	55	GND
14	Data5+(B)	35	---	56	---
15	Data5-(A)	36	---	57	---
16	---	37	---	58	GND
17	---	38	Data6+(B)	59	---
18	---	39	Data6-(A)	60	---
19	---	40	GND	61	---
20	---	41	Data7+(B)	62	---
21	---	42	Data7-(A)	---	---

# CP-138U-I

This board supports RS-422 and RS-485 (both 2 and 4-wire).

Model	Board Connector	Supported Accessories	Serial Connectors
CP-138U-I	DB78 (female)	CBL-M78M9x8-100	8×DB9 (male)
		CBL-M78M25x8-100	8×DB25 (male)

## DB78 (Female): RS-422, RS-485 (4-wire)

Pin	Signal	Pin	Signal	Pin	Signal
1	GND7	27	RxD5-(A)	53	---
2	RxD7+(B)	28	---	54	---
3	---	29	RxD4-(A)	55	---
4	GND6	30	---	56	---
5	RxD6+(B)	31	---	57	---
6	GND5	32	RxD3-(A)	58	---
7	RxD5+(B)	33	---	59	---
8	---	34	RxD2-(A)	60	TxD7-(A)
9	GND4	35	---	61	TxD7+(B)
10	RxD4+(B)	36	---	62	TxD6-(A)
11	GND3	37	RxD1-(A)	63	TxD6+(B)
12	RxD3+(B)	38	---	64	---
13	---	39	RxD0-(A)	65	TxD5-(A)
14	GND2	40	---	66	TxD5+(B)
15	RxD2+(B)	41	---	67	TxD4-(A)
16	GND1	42	---	68	TxD4+(B)
17	RxD1+(B)	43	---	69	---
18	---	44	---	70	TxD3-(A)
19	GND0	45	---	71	TxD3+(B)
20	RxD0+(B)	46	---	72	TxD2-(A)
21	---	47	---	73	TxD2+(B)
22	RxD7-(A)	48	---	74	---
23	---	49	---	75	TxD1-(A)
24	RxD6-(A)	50	---	76	TxD1+(B)
25	---	51	---	77	TxD0-(A)
26	---	52	---	78	TxD0+(B)

**DB78 (Female): RS-485 (2-wire)**

Pin	Signal	Pin	Signal	Pin	Signal
1	GND7	15	Data2+(B)	29	Data4-(A)
2	Data7+(B)	16	GND1	30	---
3	---	17	Data1+(B)	31	---
4	GND6	18	---	32	Data3-(A)
5	Data6+(B)	19	GND0	33	---
6	GND5	20	Data0+(B)	34	Data2-(A)
7	Data5+(B)	21	---	35	---
8	---	22	Data7-(A)	36	---
9	GND4	23	---	37	Data1-(A)
10	Data4+(B)	24	Data6-(A)	38	---
11	GND3	25	---	39	Data0-(A)
12	Data3+(B)	26	---	40	---
13	---	27	Data5-(A)	41	---
14	GND2	28	---	42	---

**CP-168U**

This board supports RS-232. With the OPT8F or OPT8Z accessory, it can support RS-422. With the OPT8K or OPT8I accessory, it can support RS-422 and RS-485 (both 2 and 4-wire).

Model	Board Connector	Supported Accessories	Serial Connectors
CP-168U	DB62 (Female)	OPT8-M9 CBL-M62M9x8-100 (OPT8D)	8×DB9 (Male)
		OPT8B CBL-M62M25x8-100 (OPT8C)	8×DB25 (Male)
		OPT8A, OPT8S, OPT8F, OPT8Z, OPT8K, OPT8I	8×DB25 (Female)
		OPT8-RJ45	8×RJ45

## DB62 (Female): RS-232

Pin	Signal	Pin	Signal	Pin	Signal
1	TxD0	22	RxD0	43	CTS0
2	DTR0	23	DSR0	44	RTS0
3	RxD1	24	DCD0	45	GND
4	DSR1	25	TxD1	46	CTS1
5	DCD1	26	DTR1	47	RTS1
6	TxD2	27	RxD2	48	CTS2
7	DTR2	28	DSR2	49	RTS2
8	RxD3	29	DCD2	50	GND
9	DSR3	30	TxD3	51	CTS3
10	DCD3	31	DTR3	52	RTS3
11	RxD4	32	GND	53	CTS4
12	DSR4	33	TxD4	54	RTS4
13	DCD4	34	DTR4	55	GND
14	TxD5	35	RxD5	56	CTS5
15	DTR5	36	DSR5	57	RTS5
16	RxD6	37	DCD5	58	GND
17	DSR6	38	TxD6	59	CTS6
18	DCD6	39	DTR6	60	RTS6
19	RxD7	40	GND	61	CTS7
20	DSR7	41	TxD7	62	RTS7
21	DCD7	42	DTR7	---	---

## POS-104UL

This board supports RS-232 only.

Model	Board Connector	Supported Accessories	Serial Connectors
POS-104UL	DB44 (female)	CBL-M44M9x4-50(POS)	4×DB9 (male)

## DB44 (Female): RS-232

Pin	Signal	Pin	Signal	Pin	Signal
1	TxD3	16	CTS3	31	DCD3
2	RxD3	17	DTR3	32	---
3	RTS3	18	DSR3	33	GND
4	5V/12V/RI3	19	---	34	---
5	TxD2	20	CTS2	35	DCD2
6	RxD2	21	DTR2	36	---
7	RTS2	22	DSR2	37	GND
8	5V/12V/RI2	23	---	38	---
9	TxD1	24	CTS1	39	DCD1
10	RxD1	25	DTR1	40	---
11	RTS1	26	DSR1	41	GND
12	5V/12V/RI1	27	---	42	DCD0
13	TxD0	28	CTS0	43	5V/12V/RI0
14	RxD0	29	DTR0	44	GND
15	RTS0	30	DSR0	---	---

# CP-102UF

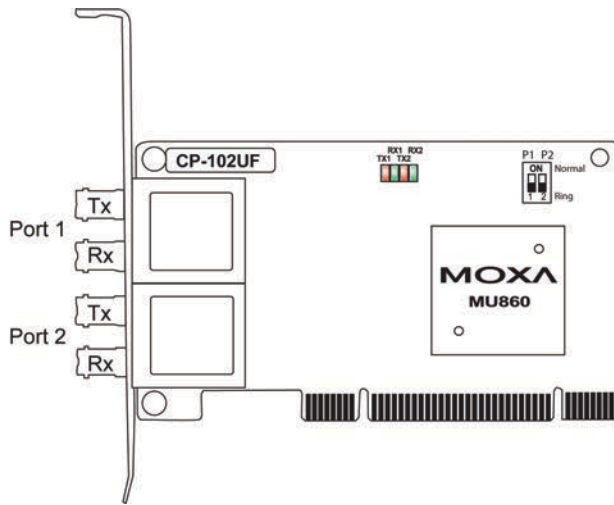

## Serial Connectors

### DB9 (Male)

The following accessories provide DB9 (male) serial connectors for your UPCI board:

Accessory	Board Connector	Serial Connectors
CBL-M25M9x2-50	DB25 (female)	2×DB9 (male)
CBL-M44M9x4-50	DB44 (female)	4×DB9 (male)
CBL-M44M9x4-50(POS)	DB44 (female)	4×DB9 (male)
CBL-RJ45M9-150	RJ45	4×DB9 (male)
OPT8-M9	DB62 (female)	8×DB9 (male)
CBL-M62M9x8-100 (OPT8D)	DB62 (female)	8×DB9 (male)
CBL-M78M9x8-100	DB78 (female)	8×DB9 (male)

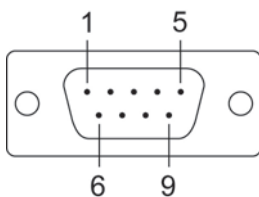

The pin assignments for the DB9 (male) serial connector are shown below. There are different pin assignments depending on the serial interface that your board is configured for.

Pin	RS-232	RS-422/RS-485 (4W)	RS-485 (2W)
1	DCD	TxD-(A)	---
2	RxD	TxD+(B)	---
3	TxD	RxD+(B)	Data+(B)
4	DTR	RxD-(A)	Data-(A)
5	GND	GND	GND
6	DSR	---	---
7	RTS	---	---
8	CTS	---	---
9	*5V/12V/RI	---	---

\* The 5V/12V/RI signal only applies to the POS-104UL

## DB25 (Male)

The following accessories provide DB25 (male) serial connectors for your UPCI board:

Accessory	Board Connector	Serial Connectors
CBL-M44M25x4-50	DB44 (female)	4×DB25 (male)
CBL-RJ45M25-150	RJ45	4×DB25 (male)
OPT8B CBL-M62M25x8-100 (OPT8C)	DB62 (female)	8×DB25 (male)
CBL-M78M25x8-100	DB78 (female)	8×DB25 (male)

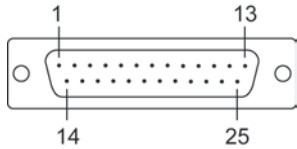

The pin assignments for the DB25 (male) serial connector are shown below. There are different pin assignments depending on the serial interface that your board is configured for.

Pin	RS-232	RS-422/RS-485 (4W)	RS-485 (2W)
2	TxD	RxD+ (B)	Data+ (B)
3	RxD	TxD+ (B)	---
4	RTS	---	---
5	CTS	---	---
6	DSR	---	---
7	GND	GND	GND
8	DCD	TxD- (A)	---
20	DTR	RxD- (A)	Data- (A)

## DB25 (Female)

The following accessories provide DB25 (female) serial connectors for your UPCI board:

Accessory	Board Connector	Serial Connectors
OPT8A, OPT8S, *OPT8F, *OPT8Z, *OPT8K, *OPT8I	DB62 (female)	8×DB25 (female)

\* The OPT8F, OPT8Z, OPT8K, and OPT8I are designed for use with the CP-168U only.

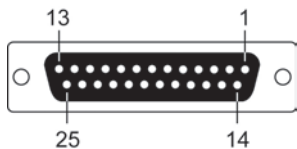

The pin assignments for the DB25 (female) serial connector are shown below. There are different pin assignments depending on the serial interface that your board is configured for.

**OPT8A, OPT8S**

Pin	RS-232	RS-422/RS-485 (4W)	RS-485 (2W)
2	RxD	TxD+ (B)	---
3	TxD	RxD+ (B)	Data+ (B)
4	CTS	---	---
5	RTS	---	---
6	DTR	RxD- (A)	Data- (A)
7	GND	GND	GND
8	DCD	TxD- (A)	---
20	DSR	---	---

**OPT8F, OPT8Z, OPT8K, OPT8I**

Pin	RS-422/RS-485 (4W)	RS-485 (2W)
2	RxD+ (B)	Data+ (B)
3	TxD+ (B)	---
7	GND	GND
14	RxD- (A)	Data- (A)
16	TxD- (A)	---

**RJ45**

The following accessories provide RJ45 serial connectors for your UPCI board:

Accessory	Board Connector	Serial Connectors
OPT8-RJ45	DB62 (female)	8×RJ45

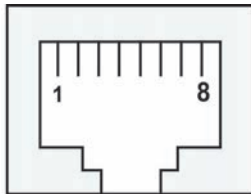

The pin assignments for the RJ45 serial connector are shown below. Only RS-232 is supported. The OPT8-RJ45 accessory should only be used with the CP-118U in RS-232 mode or with the CP-168U.

Pin	RS-232
1	DSR
2	RTS
3	GND
4	TxD
5	RxD
6	DCD
7	CTS
8	DTR