

Moxa VPort 2310 Video Server

User's Manual

Second Edition, June 2008



© 2008 Moxa Inc., all rights reserved.
Reproduction without permission is prohibited.

VPort 2310 User's Manual

The software described in this manual is furnished under a license agreement and may be used only in accordance with the terms of that agreement.

Copyright Notice

Copyright © 2005 Moxa Networking Co., Ltd.
All rights reserved.
Reproduction without permission is prohibited.

Trademarks

MOXA is a registered trademark of the Moxa Group.
All other trademarks or registered marks in this manual belong to their respective manufacturers.

Disclaimer

Information in this document is subject to change without notice and does not represent a commitment on the part of Moxa.

Moxa provides this document “as is,” without warranty of any kind, either expressed or implied, including, but not limited to, its particular purpose. Moxa reserves the right to make improvements and/or changes to this manual, or to the products and/or the programs described in this manual, at any time.

Information provided in this manual is intended to be accurate and reliable. However, Moxa Networking assumes no responsibility for its use, or for any infringements on the rights of third parties that may result from its use.

This product might include unintentional technical or typographical errors. Changes are periodically made to the information herein to correct such errors, and these changes are incorporated into new editions of the publication.

Technical Support Contact Information

www.moxa.com/support

Moxa Americas:

Toll-free: 1-888-669-2872

Tel: +1-714-528-6777

Fax: +1-714-528-6778

Moxa China (Shanghai office):

Toll-free: 800-820-5036

Tel: +86-21-5258-9955

Fax: +86-10-6872-3958

Moxa Europe:

Tel: +49-89-3 70 03 99-0

Fax: +49-89-3 70 03 99-99

Moxa Asia-Pacific:

Tel: +886-2-8919-1230

Fax: +886-2-8919-1231

Before getting started

Before using your VPort 2310, please pay close attention to the following items:

- ❑ After opening the VPort 2310 box, compare the contents of the box with the **Package Checklist in Chapter 1**. Notify your sales representative if any of the items is missing or damaged.
- ❑ To prevent damage or problems caused by improper usage, before assembling and operating the device and peripherals, read the **Quick Installation Guide** (the printed handbook included in the package). You may also refer to **Chapter 1**, under **Product Description**, and all of **Chapter 2**, of this manual.
- ❑ If you experience a system error, and the system does not recover easily, refer to the **Troubleshooting** section in **Chapter 7** to learn how to restore factory default settings and reinstall the system.
- ❑ The VPort 2310 Video Server has been designed for various environments and can be used to build various applications for general security or demonstration purposes. For standard applications, refer **Chapter 2, Getting Started**, and **Chapter 3, Accessing VPort 2310 Video Server for the First Time**.

Important Note

- ❑ Surveillance devices may be prohibited by law in your country. Since VPort is both a high performance surveillance system and networked video server, ensure that the operations of such devices are legal in your locality before installing this unit for surveillance purposes.

Table of Contents

Chapter 1	Introduction	1-1
	Overview.....	1-2
	Package Checklist	1-3
	Product Features	1-4
	Typical Application.....	1-4
	Product Description	1-5
	Front Panel.....	1-5
	Rear Panel.....	1-5
Chapter 2	Getting Started	2-1
	Before Getting Started	2-2
	Hardware Installation.....	2-2
	Assigning an IP Address	2-3
	DHCP Server Environment	2-3
	Non-DHCP Server Environment	2-4
	Assigning the IP Address Manually	2-5
	Mounting VPort 2310	2-5
	Panel Mounting.....	2-5
	DIN-Rail Mounting	2-5
Chapter 3	Accessing VPort 2310 for the First Time	3-1
	Accessing VPort 2310.....	3-2
	Opening Your Browser.....	3-2
	Authentication	3-2
	Installing the Plug-in Application.....	3-3
	Functions Featured on VPort's Homepage.....	3-4
	Logo and Host Name.....	3-4
	Camera Image View	3-4
	System Configuration.....	3-4
	Taking Snapshots.....	3-4
	Digital Zoom	3-4
	Relay Output Control.....	3-5
	Motorized (PTZ) Camera Control	3-5
	Custom PTZ Camera Commands	3-5
	Client Settings.....	3-5
Chapter 4	System Configuration	4-1
	System Configuration via Web Access	4-2
	System	4-2
	Security.....	4-4
	Network.....	4-5
	DDNS & UPnP.....	4-8
	Video	4-10
	Motion Detection.....	4-13
	Application	4-15
	Camera Control.....	4-19
	Homepage Layout.....	4-23
	View log file.....	4-24
	View parameters	4-24

	Factory default.....	4-25
	System Configuration via FTP.....	4-25
	CONFIG.INI.....	4-25
	System Configuration Via Telnet	4-32
	Telnet Commands.....	4-32
	System core debugging.....	4-32
	Monitoring changes to digital input status.....	4-32
	Stop information dumping.....	4-32
	Query status of digital inputs	4-32
	Set digital outputs	4-32
	Erase snapshots stored in Flash memory	4-32
	Skip installation at next boot	4-32
	Erase logo and graphic buttons.....	4-33
	Reset network	4-33
	Restore factory default settings.....	4-33
	Reset system	4-33
Chapter 5	Advanced Applications	5-1
	Capturing Up-to-date Still Images	5-2
	Getting snapshot via URL	5-2
	Getting snapshot via FTP.....	5-2
	Video Embedded in Customers' Homepage.....	5-2
	Download Event-triggered Snapshots.....	5-3
	Getting triggered snapshots via URL.....	5-3
	Getting triggered snapshots via FTP.....	5-3
	Customizing Homepage Graphics	5-3
	URL Commands for DI/DO & Camera's Actions Setting	5-4
	Query status of digital inputs	5-4
	Drive digital outputs	5-4
	Moving motorized camera in PTZ direction.....	5-4
	Recalling camera position.....	5-4
	Transparent Remote Serial Driver	5-4
	Sending commands to devices attached to the COM port	5-5
	URL Commands for System Maintenance.....	5-5
	Download System Log via FTP.....	5-5
	Restart System via URL	5-5
	Restore Factory Default Settings via URL	5-5
Chapter 6	Upgrading System Firmware	6-1
	Using Upgrade Wizard to Upgrade Firmware.....	6-2
	Using FTP to Upgrade Firmware.....	6-3
Chapter 7	Troubleshooting.....	7-1
	Power on Self Test (POST)	7-2
	Frequently Asked Questions	7-2
Appendix A	URL Commands of Video Server	A-1
	Page URL.....	A-1
	System Resource URL.....	A-2
	General Format of Command URL	A-2
	System Configuration URL	A-2
	Security configuration URL.....	A-2
	Network configuration URL	A-3

Video configuration URL	A-4
Image quality configuration URL	A-5
Camera configuration URL.....	A-5
Camera preset configuration URL	A-5
Camera custom command configuration URL	A-5
Custom camera configuration URL	A-6
Application configuration URL	A-6
Homepage layout configuration URL.....	A-7
DDNS & UPNP configuration URL	A-7
Appendix B Settings of Supported PTZ Cameras.....	B-1
Appendix C Camera Control Cable	C-1
Appendix D Time Zone Table.....	D-1
Appendix E Technical Specifications	E-1

1

Introduction

VPort 2310 is a high-performance networking video server. In addition to meeting the basic needs of video feed, many advanced features are included to help you set up surveillance or web attraction applications. VPort 2310 is designed to provide stability, robustness, ease-of-use, and flexibility.

The following topics are covered in this chapter:

- ❑ **Overview**
- ❑ **Package Checklist**
- ❑ **Product Features**
- ❑ **Typical Application**
- ❑ **Product Description**
 - Front Panel
 - Rear Panel

Overview

VPort 2310 is a 1-channel Video Server that adopts the high performance MPEG4 compression algorithm to enhance the efficiency of video transmission via the IP network. Equipped with BNC video input, image digitizer, image compressor (DSP) and 10/100 Mbps Ethernet connectivity, VPort 2310 can digitize any analog video source and distribute these digital images over an IP network, turning your CCTV system into a "Video over IP" Network System INSTANTLY. In addition, VPort 2310 also provides synchronized Video/Audio output due to the adoption of MPEG4 technology, giving the user a more realistic video/audio surveillance system.

High Performance MPEG4 compression

Video input can be efficiently compressed into packets of MPEG4 video stream without delay. This is all done without sacrificing remote monitoring capability or storage. Five levels of compression ratio and three different image resolutions are provided to provide more versatility.

Audio supported for a complete surveillance solution

The MPEGx series algorithm allows both voice and video to be compressed together to provide users with more versatile applications, such as VCD (MPEG1), DVD (MPEG2), Internet Multimedia Broadcast (MPEG4), etc. VPort 2310 introduces users to a brand new kind of synchronized video/audio surveillance over IP network.

Easy Web access via standard browsers

There is no need to install new software to access the Video Server, since the embedded Web Server allows users to use any popular web browser to access the Video Server from anywhere over the Internet. As long as you are connected to the network, you will be able to view the same images seen by your cameras.

User password protection

User password protection is provided to prevent malicious intruders from accessing your system. Once the administrator password is configured, all users will need a password to access the Video Server.

Built-in 3 area-selectable Video Motion Detection (VMD)

External sensors are not required, since the video channel can be configured to detect motion in 3 areas, making it easy to set up a security system in either your office or the field. And the customizable settings allow you to tune the system for both object size and sensitivity, making the Video Server adaptable to different environments.

Weekly schedule for automated surveillance

The user-defined time period will check security settings on a weekly basis, and send notifications or drive external devices, making VPort 2310 suitable for more versatile applications.

Flexible I/O control for external devices

One opto-isolated sensor input and one relay output are provided to control external devices, giving system integrators the option of turning an analog system into an advanced security system.

Moxa SoftDVR Lite IP Surveillance Software

To extend the Video Server's capabilities, Moxa SoftDVR™ Lite IP Surveillance Software, which supports a maximum of 4 cameras in quad, is included free of charge, allowing users to turn their PC into a digital video recorder. Scheduling or one-click recording saves important images on your local hard disk, and the reliable motion detection and instant warning features make you ready for any situation. A quick and easy to use search and playback function lets you easily find the image you're looking for, so that you can inspect the images more carefully, and also save the output to an AVI file.

Remote system upgrade

Video Server users have round-the-clock access to the most up-to-date firmware on our website, with a free upgrade wizard included to facilitate firmware installation.

Technical support for developers

The high-performance Video Server can be integrated into many applications—without busting your budget—and the complete programming interface of Moxa ActiveX Control SDK makes the developer's job easy and straightforward. More ideas for Video Server applications can be found on our website.

Package Checklist

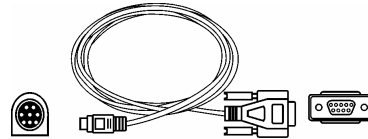
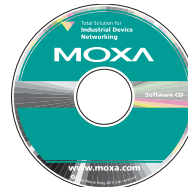
1 VPort 2310 Video Server**Power adaptor****GPIO terminal block****Camera control cable****Software CD****Wrench**

NOTE: Notify your sales representative if any of the above items is missing or damaged.

Product Features

VPort 2310 products have the following features:

- Compact size, 1-ch MPEG4 Video Server
- 1 BNC video input and 1 RCA Audio Input
- Video stream up to 30 frames/sec in CIF (352 x 240) resolution
- Remote access with built-in web server for viewing and configuring
- Optimal solution by adjustable frame rate, bandwidth, and quality
- 3 area selectable Video Motion Detection (VMD) with Pre/Event/Post images
- TCP, UDP and HTTP (No audio) client settings for network transmission
- Supports DDNS & UPnP protocols
- General I/O for external sensor and alarm
- Supports 1 RS-232/485 COM port for PTZ camera control
- Alarm with images transmitted via FTP or e-mail
- Password protection and administrator privilege
- Customized personal homepage
- Remotely upgrade the firmware to keep it up to date
- Moxa SoftDVR™ IP Surveillance Software for viewing and recording bundled free

NOTE: *ActiveX Control SDK supports a flexible interface and sample codes for third-party developers (contact a Moxa sales representatives for more information about this SDK).*

Typical Application

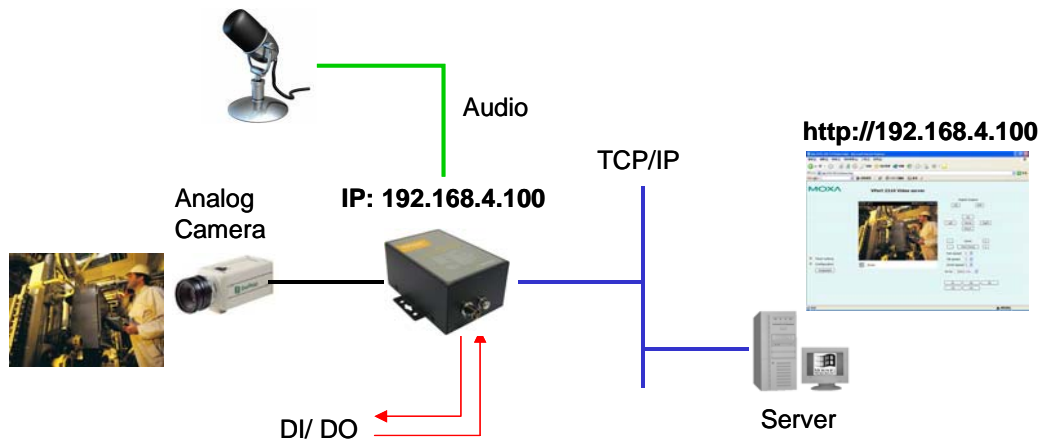

Product Description

Front Panel

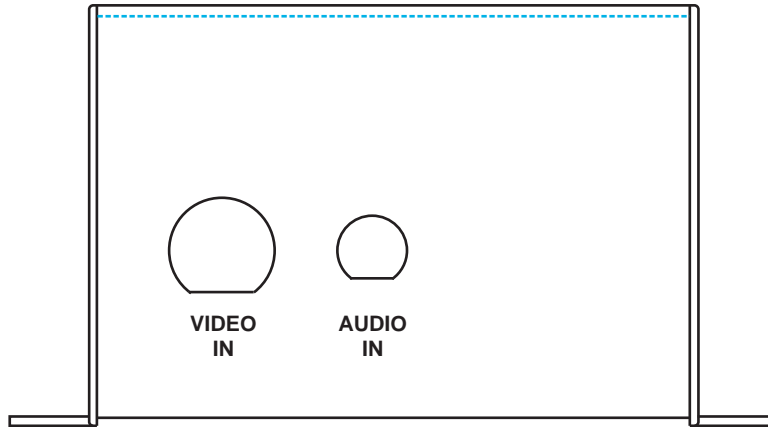

BNC video input

The BNC video input is a 75 Ohm video port for connecting an external camera. To ensure that the correct video modulation type is detected, cameras should be connected and powered on before the VPort is powered on.

RCA audio input

The audio input is connected by an RCA connector, mono-audio line-in signal.

Rear Panel

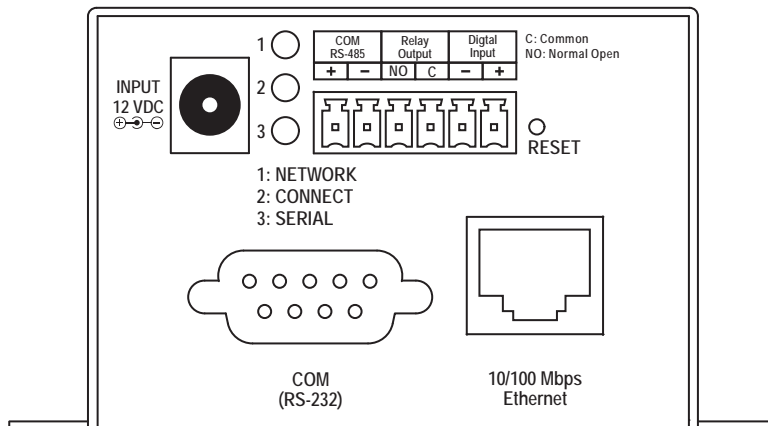

Network and Status LEDs

Each time the Video Server starts up, it performs a Power-On-Self-Test (POST) to examine each hardware module. VPort 2310 Video Server has 3 LEDs:

1. **NETWORK**: detects the network's Tx/Rx status
2. **CONNECT**: checks if the Video Server alive or not
3. **SERIAL**: checks if the RS-232/485 COM port alive or not

As soon as the administrator plugs in the power connector, both the CONNECT and SERIAL LED's will flash, one by one, until the diagnosis is finished. If the result is okay, these 2 LEDs will turn off momentarily, and then follow the pattern shown in the table below. If any of the modules fails, refer to **Chapter 7, Troubleshooting**, under **Power On Self Test** for the error pattern, and then follow the troubleshooting procedures. If the system still does not operate normally, contact your reseller for technical service.

Condition		LED1 (NETWORK)	LED2 (CONNECT)	LED3 (SERIAL)
Ethernet alive	VPort's IP is assigned	Flash	Flash	OFF
	VPort's IP is not assigned	Flash	OFF	OFF
Ethernet defunct		OFF	OFF	ON after 30 sec
During camera control		Flash	Flash	Flash

10/100 Mbps Ethernet port

Use a UTP category 5 cable shorter than 100 meters to connect to an Ethernet network. Once the Ethernet connection is established, the Video Server will use the Ethernet interface instead of the modem attached to the COM port.

RS-232 COM port

If the Video Server is connected to the network via the Ethernet interface, you can use the RS-232 serial port to control a PTZ camera.

General I/O terminal block

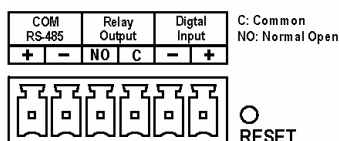

COM RS-485	+	Data+	
	-	Data-	
Relay Output	NO	Normal Open	Max. 1A, 24 VDC or 0.5A, 125 VAC
	C	COMMON	Short with Normal Close at the initial state
Digital Input	-	DI-	
	+	DI+	Max. 50 mA, 12 VDC

The Video Server provides a very flexible general I/O interface that can be used with security devices, such as sensors, alarms, lighting fixtures, or door locks. The general I/O terminal block has six pins for device control. These pins can be divided into two categories based on the interface being used (RS-485 or DI/DO).

RS-485 COM

If the device (such as a PTZ camera control) connected to COM has an RS-485 interface, wire the RS-485 Data+ and Data- control lines to COM RS-485's "+" pin and "-" pin.



ATTENTION

Since RS-485 COM and RS-232 COM share the same UART chip, either RS-485 or RS-232 (but not both) can be used.

Digital Input/Relay Output

VPort 2310 Video Server provides one digital input and one relay output. The Digital Input's "+" pin and "-" pin can be connected to an external sensor to monitor the voltage according to the programmed scripts in configuration (see the "Command Script for DI/DO & Camera's Actions Setting" in Chapter 5). The Relay Output's "NO" pin and "C" pin can be used to turn an external alarm on or off.

Reset Button



A recessed RESET button is provided for restoring the system to the factory default settings. When the system fails to install properly, or operates abnormally, use the wrench included in the package to reset the system back to its original status. The procedure is as follows:

- Step 1: Insert the wrench into the hole to press down on the reset button, which is located about 1.5 cm inside the surface of the casing.
- Step 2: While keeping the reset button pressed, restart the system by powering off and on.
- Step 3: The system will perform POST twice rather than the once. You can verify this by observing the flashing "CONNECT" and "SERIAL" LEDs.
- Step 4: After the system flashes the LEDs for the second time, withdraw the wrench to release the button. The system will now be restored to the factory default settings.

12 VDC Power Adaptor

Connect the power jack of the included power adaptor. Connecting the power adaptor should be the last step involved in the Video Server hardware installation.

2

Getting Started

This chapter includes information about how to install a VPort 2310 Video Server.

The following topics are covered:

- ❑ **Before Getting Started**
- ❑ **Hardware Installation**
- ❑ **Assigning an IP Address**
 - DHCP Server Environment
 - Non-DHCP Server Environment
 - Assigning the IP Address Manually
- ❑ **Mounting VPort 2310**
 - Panel Mounting
 - DIN-Rail Mounting

Before Getting Started

In what follows, “user” refers to those who can access the Video Server, and “administrator” refers to the person who knows the root password that allows changes to the Video Server’s configuration, in addition to providing general access. Administrators should read this part of the manual carefully, especially during installation.

Hardware Installation

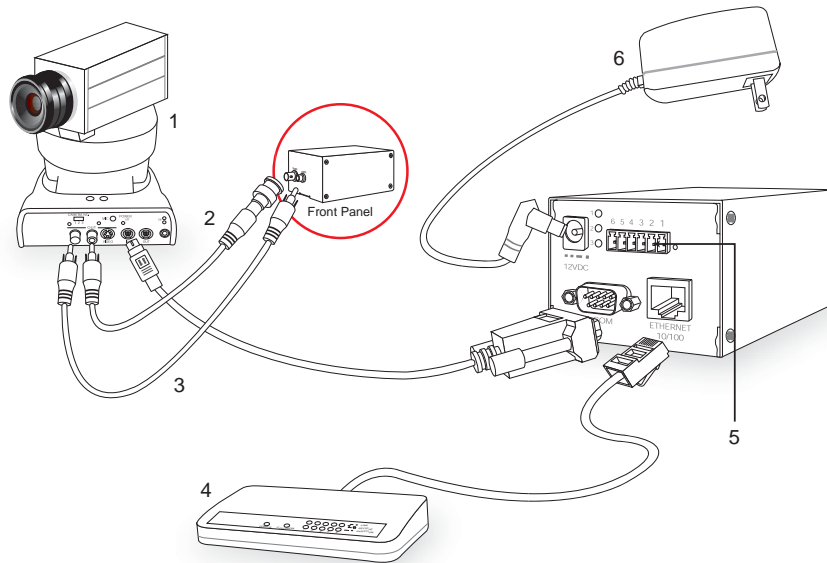

Before powering on the Video Server, you should:

1. Connect your camera’s video output to the BNC video input.
2. Connect your audio source to the RCA audio input.
3. Connect VPort’s COM port to your camera’s COM port if you are using a PTZ camera.
4. Connect the hub or switch on the LAN to the VPort’s 10/100 Mbps Ethernet port.
5. Connect I/O devices (such as sensors or alarms) to VPort’s GPIO Terminal Block.
6. Connect the power supply.

Assigning an IP Address

DHCP Server Environment

In this case, the IP address of VPort 2310 is assigned by a DHCP Server. Use the DHCP Server's IP address table, or use the Moxa IP Reporter utility to determine the IP address that was assigned by the DHCP Server.

NOTE After powering on the VPort 2310, wait a few seconds for the POST (Power On Self Test) to run. The IP address will be assigned when the CONNECT LED is lit.

Using IP Reporter

1. Run **IPReporter.exe** to search for the VPort. After the IP Reporter window opens, you may also click on the Search button to initiate a search.

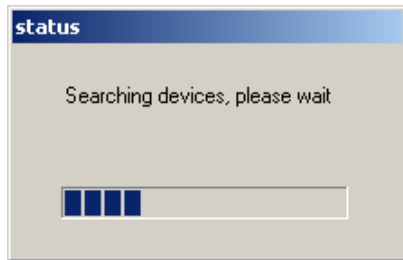

2. When the search has concluded, the MAC address and IP address of the VPort will be listed in the IP Reporter window.

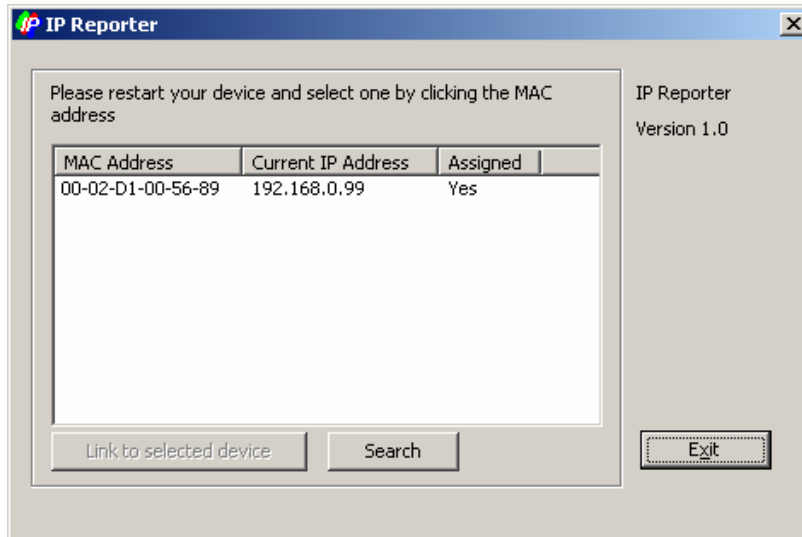

NOTE If the VPort has been assigned an IP address, the **Assigned** status will be listed as **Yes**. If the VPort has not been assigned an IP address, the Assigned status will not be listed as Yes. In this case, check to see if the VPort's firmware version supports the DHCP installation function, or if there is any problem with the network environment.

- Click on the VPort whose MAC address matches the one you just installed, and then click on **Link to the selected device** to access the VPort via your web browser. You will be able to modify VPort's IP address and other settings when the VPort's homepage opens.

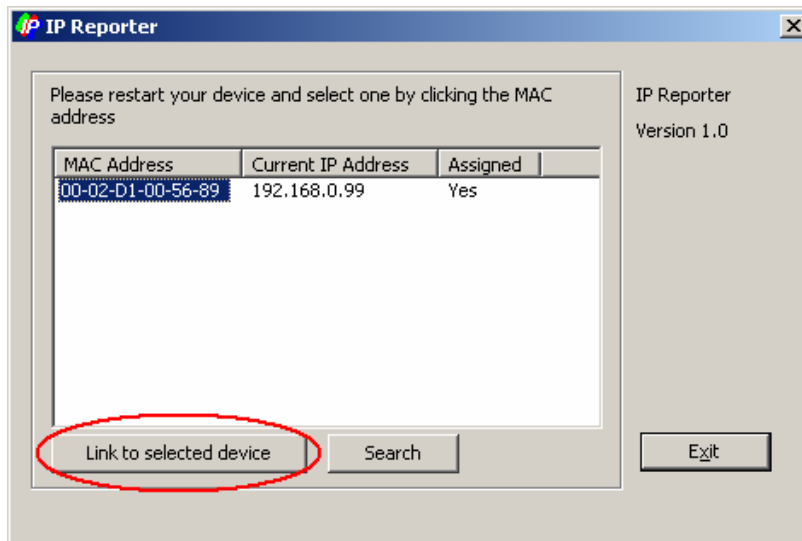

Non-DHCP Server Environment

If your VPort 2310 is connected to a network that does not have a DHCP server, then you will need to configure the IP address manually. There are two ways to access the server:

- If one VPort 2310 is connected to the network, open your web browser and type the default IP address in the browser's address box. In this case, the default IP address is 192.168.0.99 and the default subnet mask is 255.255.255.0. Note that you may need to change your computer's IP address and subnet mask so that the computer is on the same subnet as the VPort.
- If two or more VPort 2310s are connected to the network, default IP addresses of 192.168.0.99, 192.168.0.100, etc., will be assigned to the VPorts. In this case, you can use Moxa's IP Reporter utility to locate each VPort connected to the network. Since IP Reporter searches by MAC address, the VPort and computer just need to be connected to the same Ethernet LAN for IP Reporter to locate the VPort.

NOTE VPort's Network and Status LEDs can be used to determine if the VPort is transmitting and receiving data over the network. Refer to Chapter 1 to see how to interpret the Network and Status LEDs.

Assigning the IP Address Manually

To change the IP address of VPort manually, access VPort's web server, and then navigate to the **Configuration** → **Network** page to configure the IP address and other network settings. Uncheck the **Reset IP address at next boot** to ensure that the IP address you assign is not deleted each time the VPort is restarted.

The screenshot shows the 'MOXA VPort Video Server Configuration' page. The 'Network' tab is selected. Under the 'General' section, the 'Reset network at next boot' checkbox is unchecked. The IP address is 192.168.2.99, Subnet mask is 255.255.255.0, Default router is 192.168.2.254, Primary DNS is 192.168.1.46, and Secondary DNS is 54.4.192.168. Below this are sections for SMTP and FTP settings.

Annotations:

- Red arrow pointing to the unchecked 'Reset network at next boot' checkbox: "uncheck to keep VPort's IP fixed"
- Red arrow pointing to the IP address field: "Change IP and network setting manually"

Mounting VPort 2310

Panel Mounting

The VPort 2310 Video Server can be mounted directly to the wall using 2 screws with diameter larger than 7 mm.

DIN-Rail Mounting

A 35 mm DIN-Rail mounting option—the DK-35 DIN-Rail mounting kit—can be ordered from Moxa.



Accessing VPort 2310 for the First Time

This chapter includes information about how to access VPort 2310 Video Server for the first time. The following topics are covered:

- ❑ **Accessing VPort 2310**
 - Opening Your Browser
 - Authentication
 - Installing the Plug-in Application
- ❑ **Functions Featured NPort's Homepage**
 - Logo and Host Name
 - Camera Image View
 - System Configuration
 - Taking Snapshots
 - Digital Zoom
 - Relay Output Control
 - Motorized (PTZ) Camera Control
 - Custom PTZ Camera Commands
 - Client Settings

Accessing VPort 2310

Opening Your Browser

Open your browser, type the VPort's IP address in the **Address** box, and then press **Enter**.

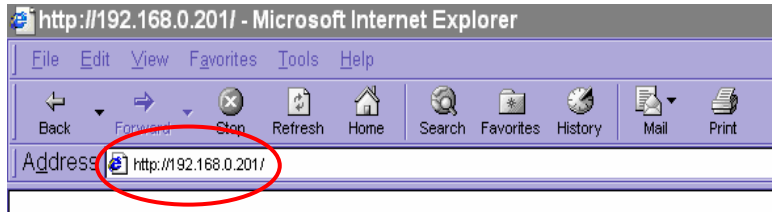

Authentication

After opening your browser and typing the VPort's IP address, you will be requested to enter the **User name** and the **Password**. When accessing the VPort for the first time, administrators must enter **root** as the username, and the **MAC address**, in capital letters, as the password. The MAC address is located on the VPort's back panel, or can be found by running IP Reporter. Primary users will be allowed to access the VPort when the administrator finishes adding user profiles. After entering a valid User name and Password, click on **OK** to open the VPort's homepage.

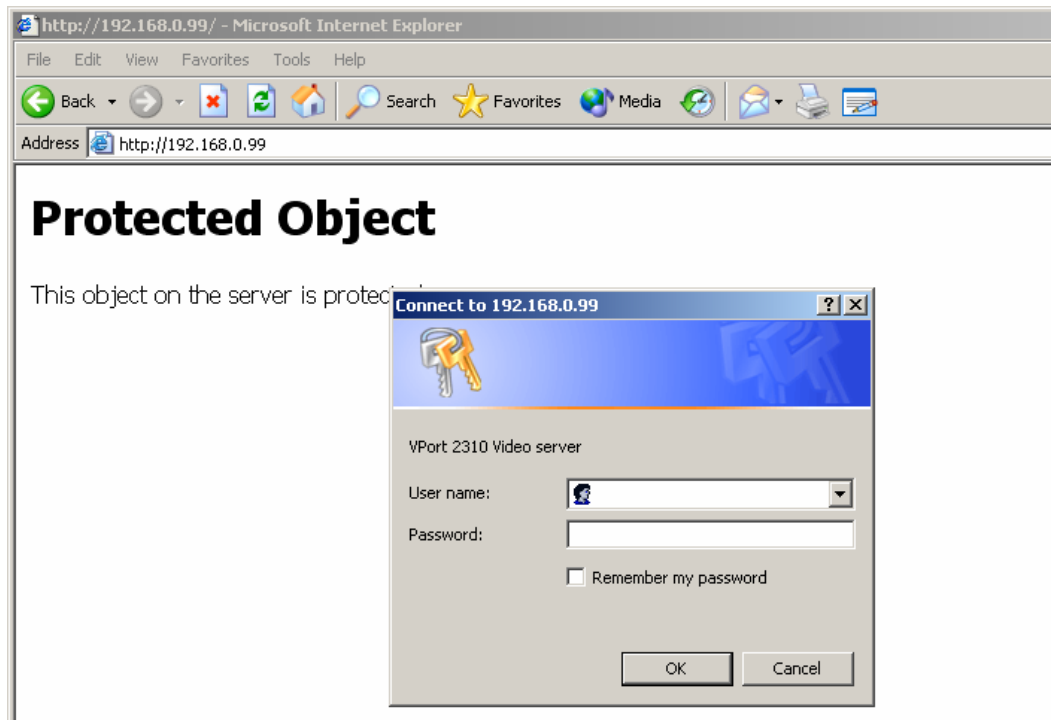

NOTE The MAC address is located on the VPort 2310's back panel. It is also shown in the IP Reporter window after the VPort has been located.

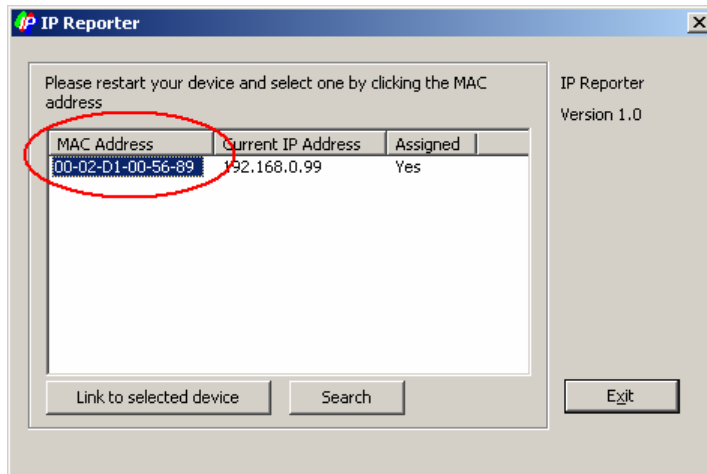

Installing the Plug-in Application

If you access the VPort for the first time via a browser that supports server push (e.g., Netscape), the video images will be displayed directly. If you are using Windows' Internet Explorer as your browser, you will be asked to install a new plug-in provided by the VPort. This plug-in has been registered for certification, and is used to display video images via Internet Explorer. Click on **Yes** to install the plug-in. If your browser does not allow the user to install the plug-in, change the security option to a lower level, or contact your network supervisor for assistance.

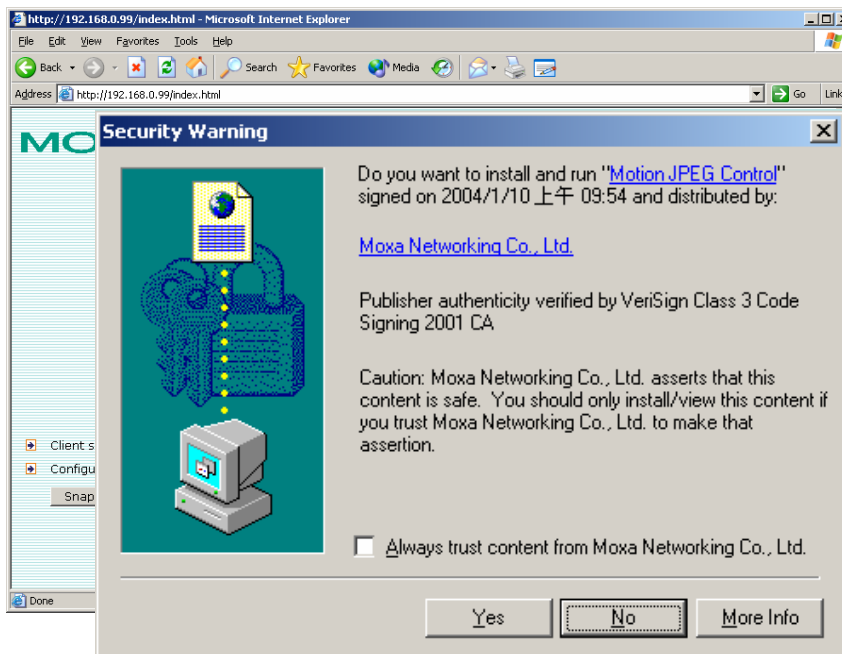

Functions Featured on VPort's Homepage

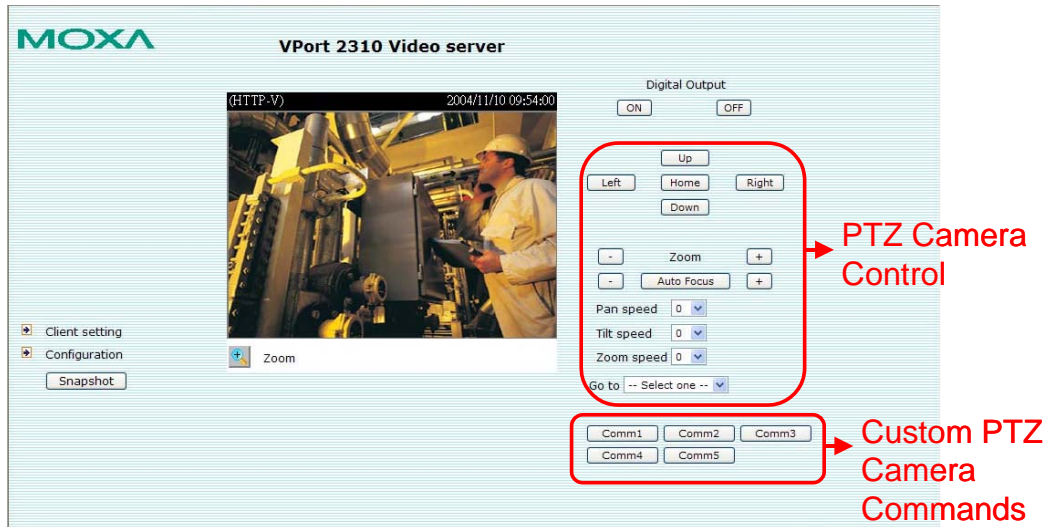

Logo and Host Name

The default logo is Moxa's logo, and the host name is VPort 2310 Video Server. For customized usage, the administrator can change the layout of the homepage from the Homepage Layout page.

Camera Image View

The assigned caption and system date/time will be displayed in the banner above the image window. Note that if VPort's motion detection function is active, you might see some windows framed in red in the video picture.

System Configuration

A button or text link on the left side of the system configuration window only appears on the administrators' main page. For detailed system configuration instructions, refer to Chapter 4, **System Configuration**.

Taking Snapshots

Users can take snapshot images for storing, printing, or editing by clicking the **Snapshot** button, and then saving the image by clicking the right mouse button.

Digital Zoom

Click the **Zoom** button to open the zoom tool in a pop-up window.



Relay Output Control

VPort 2310 Video Server has 1 DI/DO for external devices, such as sensors and alarms. If external devices are attached to the digital output, administrators or permitted users can click on **Open** to short the **Common** and **Normal Open** pins of the digital output, or click on **Close** to short the **Common** and **Normal Close** pins of the digital output.

Motorized (PTZ) Camera Control

If a serial device, such as a motorized camera, is attached to the COM port, the control panel will appear on the main page of user's who have permission to operate the camera. The active buttons will change color when the cursor is passed over the button. Users can control the pan, tilt, zoom, and focus functions of motorized cameras. The home button is used to return the camera to the center position if the camera supports this command. In addition to near and far control for focus, an AUTO button is provided for setting auto focus mode. To move the motorized camera more precisely, the speed control for pan and tilt allows users to fine tune the aiming of the camera. Users can also click directly on any point in the image to force the motorized camera to focus on that point, or select a preset location from the drop-down menu. The list of preset locations is pre-defined by administrators. The detailed configurations are described in the related section in Chapter 4, **System Configuration**.

NOTE	For some PTZ cameras, users can click on any position on the image to point the camera at that position. We currently support this functionality on Sony EVID30, Cannon VCC4, and Pelco-D PTZ cameras.
------	--

Custom PTZ Camera Commands

In addition to the default pan, tilt, zoom, and focus controls, an additional five buttons are available for custom commands to control the attached motorized (PTZ) cameras. Custom commands are set up by administrators, and are used for functions such as activating or deactivating the wiper of dome. Refer to the attached motorized device's User's Manual to see what kind of functions can be controlled with these additional buttons.

Client Settings

Users can set the following functions in **Client Settings**.

1. **Media option:** enable or disable the audio.
2. **Protocol option:** choose one of three protocols to optimize your usage—UDP, TCP, and HTTP.
 - The **UDP** protocol allows for more real-time audio and video streams. However, some packets may be lost due to network burst traffic, and images may become obscured.
 - The **TCP** protocol allows for less packet loss, and produces a more accurate video display. The downside of TCP is that the real-time effect is worse than with UDP protocol.
 - The **HTTP** protocol must be selected if the network is protected by a firewall and it only allows HTTP Port to be opened. In this mode, audio will not be sent. Only the video will be operational.

Most users choose protocols in the sequence **UDP → TCP → HTTP**. Once the Video Server is connected successfully, "Protocol Option" will indicate the selected protocol. The selected protocol will be recorded in the user's PC and will be used for the next connection. If the network environment is changed, or you want to refresh the web browser, manually select the UDP protocol, save, and then return HOME to re-connect.

Client setting

HOME

Media Option

Disable audio

Protocol Option

The auto-detection order of transmission protocol is UDP -> TCP -> HTTP

Please select one protocol as the default protocol.

UDP TCP HTTP (Video only)

Save

System Configuration

After installing the hardware, the next task required is to configure VPort 2310's settings. You may use one of three configuration methods: via web access, via FTP, and via Telnet.

This chapter includes the following sections:

❑ **System Configuration Via Web Access**

- System
- Security
- Network
- DDNS & UPnP
- Video
- Motion Detection
- Application
- Camera Control
- Homepage Layout
- View log file
- View parameters
- Factory default

❑ **System Configuration Via FTP**

- CONFIG ini

❑ **System Configuration Via Telnet**

- Telnet Commands
- System core debugging
- Monitor changes to the digital input status
- Stop information dumping
- Query status of digital inputs
- Set digital outputs
- Erase snapshots stored in Flash memory
- Erase logo and graphic buttons
- Reset network to new settings
- Restore factory default settings
- Reset system

System Configuration via Web Access

System configuration can be done remotely with Internet Explorer via the Web Server. Alternatively, administrators may type the system configuration URL, "http://<IP address of Video Server>/setup/config.html", to enter the configuration page directly. Administrators who wish to set up certain options by using the URL should refer to the relevant section in Chapter 6, "URL Commands," for advanced functions.

Five types of configuration are involved in configuring the system:

1. Since VPort 2310 Video Server is a networked video server, administrators should configure **Security, Network, Video, and DDNS & UPnP**.
2. To support PTZ camera control, administrators should configure **Camera Control**.
3. To utilize the built-in security and web attraction features, administrators should configure **Motion Detection and Application**.
4. Administrators can adjust the system date and time under **System**, or configure different homepage layouts by configuring **Homepage layout**.
5. Video Server also provides other system maintenance options, including **View log file, View parameters, and Factory default**.

System

Host name

The host name will appear as the homepage title of the main page and over the video window on the main page. The maximum string length is 40 characters or 20 characters in double-byte-character systems, such as Chinese or Japanese systems.

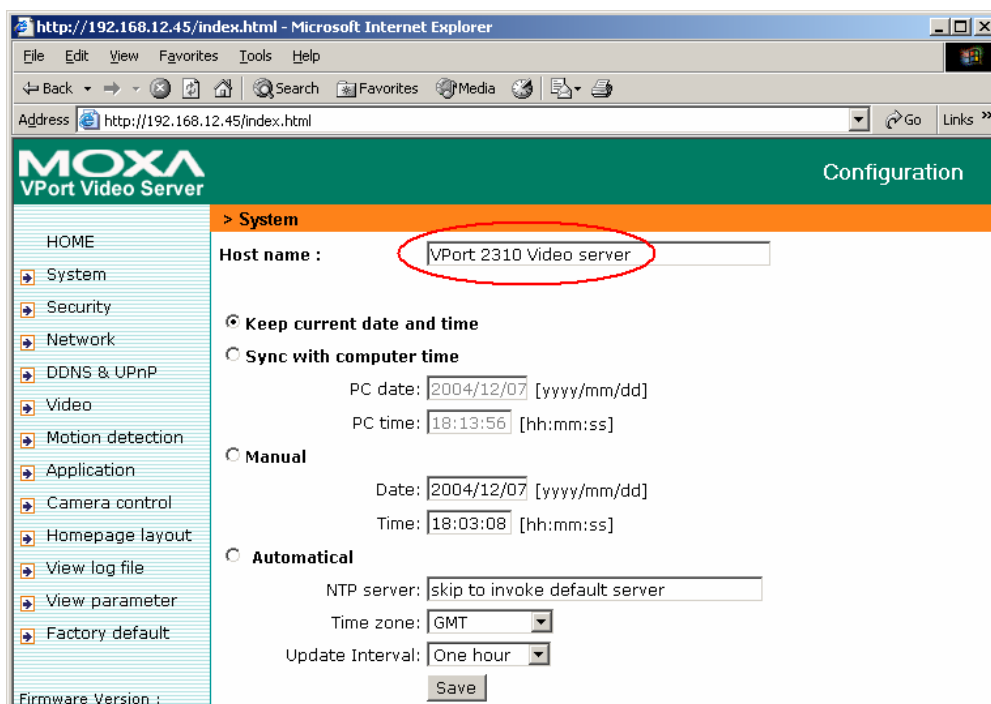

Date and Time

The default setting for Date and Time is **Keep current date and time**. You may also choose from one of the following date and time configuration options:

1. The easiest way to adjust the date and time is to make the VPort **Sync with computer time**.
2. Select the **Manual** option if you wish to set the date and time manually by entering new settings.
3. Select the **Automatical** [sic]option to make the VPort synchronize automatically with timeservers over the Internet every month. However, synchronization may fail if the assigned **NTP server** cannot be reached, or the VPort is connected to a local network. Leaving the **NTP server** blank will force the VPort to connect to default timeservers. Enter either the Domain name or IP address format of the timeserver as long as the DNS server is available. Do not forget to set the **Time zone** for local settings. Refer to Appendix G for your region's time zone.

Click on **Save** to validate changes.

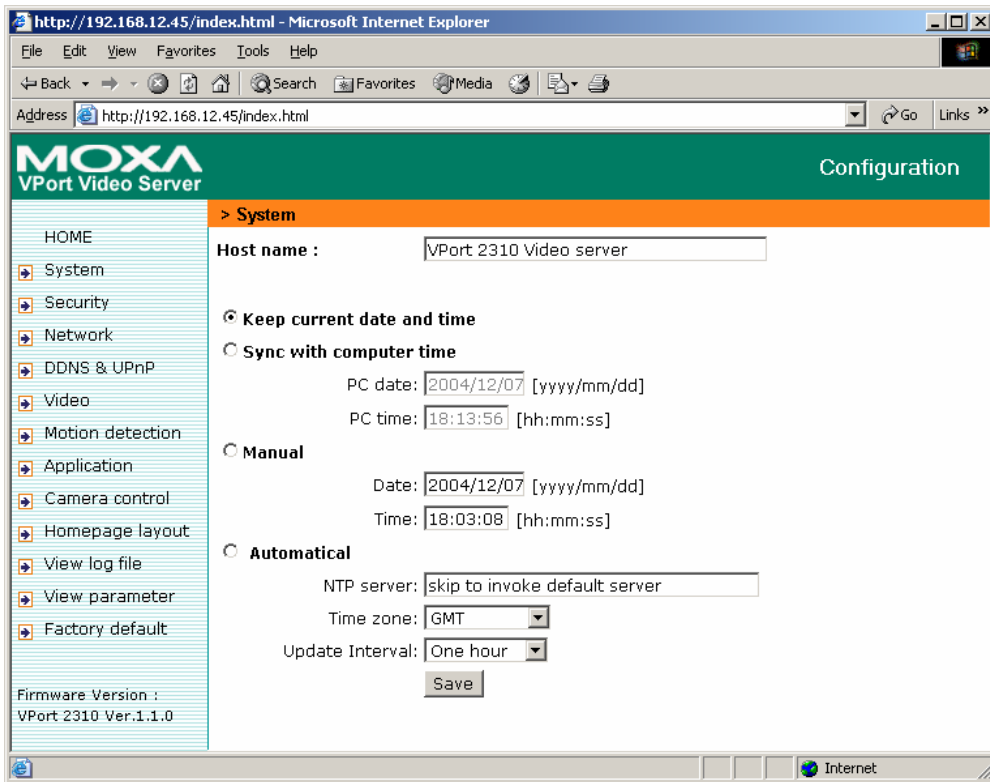

Security

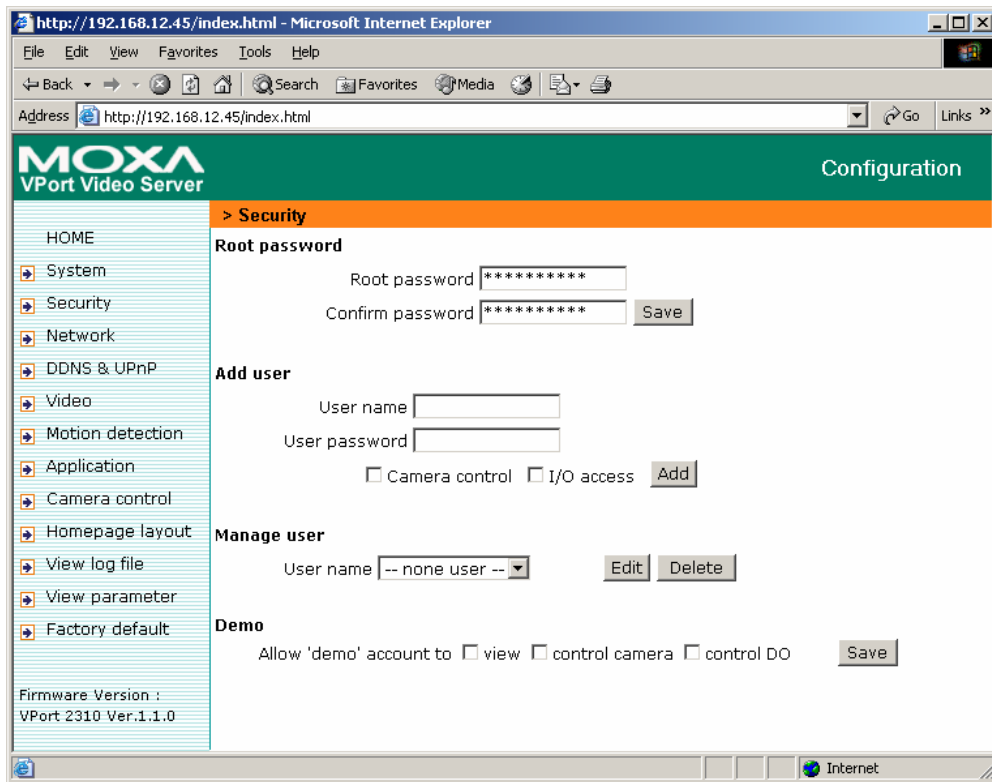

Root password

To change the administrator's password, type the new password in both the **Root password** box and **Confirm password** box. The passwords you enter will be displayed in asterisks for security reasons. The maximum string length for a password is 14 characters. After clicking on **Save** to validate the new password, a window will open to ask the administrator for the new password to access the VPort.

Add user

To add a new user, type the new user's name in the **Username** box, the password in the **User password** box, and select authorization level by checking **I/O access** or **Camera control**. Click on **Add** to insert the entry. The VPort 2310 Video Server has a total of 20 user accounts. Each user can be given an independent access right to the external I/O and camera control.

Manage user

If the access rights of some users need to be changed, find the user name from the drop down list and click on **Edit**. A new window will appear for the administrator to change the password and select a different authorization. Administrators can also delete the selected user by clicking on **Delete**. A message window will open next to confirm.

Demo

VPort 2310 Video Server provides a demonstration mode to allow general access for demonstration purposes. To set up the demonstration mode, administrators must choose the services to be permitted. If administrators select the **view** option, users may use **demo** as the username to access the VPort. In this case, leave the password field blank. Administrators can also select **control camera** or **control DO** options for the demo account. Separating the demo account from the primary users can prevent interference with normal operations.

Network

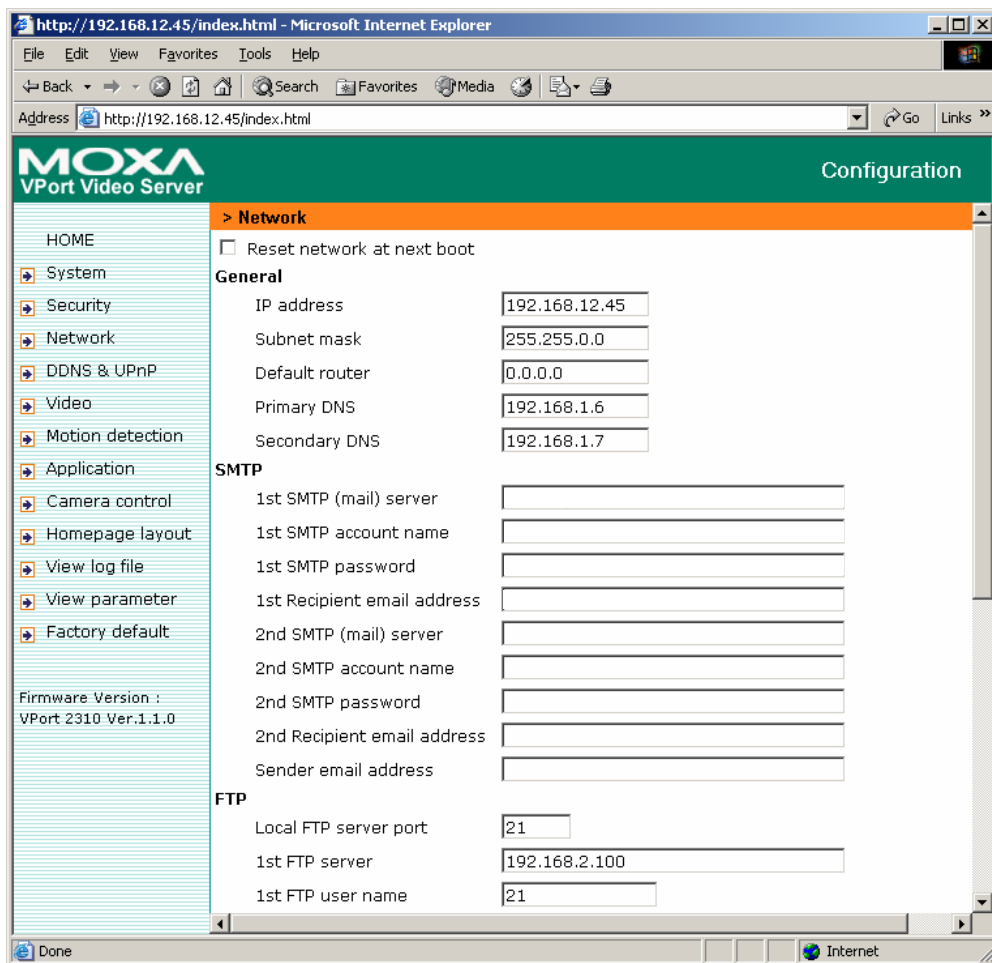

Reset network at next boot

1. **Reset network at next boot**

In this case, the installation process will be run again when the system reboots (i.e., when you save system configuration or re-power on the VPort). The IP address of VPort 2310 may be changed if the VPort is in a DHCP Server environment. This is the default setting of VPort 2310 Video Server.

2. **Reset network at next boot**

In this case, VPort 2310 Video Server will skip the installation process at the next system reboot, which means the IP address is fixed to VPort 2310 Video Server. The advantage of disabling the "Reset network at next boot" option is that the VPort will automatically operate normally after being restarted after a power loss.

NOTE VPort's Network and Status LEDs can be used to determine if the VPort is transmitting and receiving data over the network. Refer to Chapter 1 to see how to interpret the Network and Status LEDs.

General

Administrators may need to modify the network settings to connect to an existing network since the subnet mask for some broadband services may differ from the default value of 255.255.255.0, and service providers may assign more specific network settings. Administrators should change the configuration to the settings given by the service provider. The configuration may include **IP address, Subnet mask, Default router, Primary DNS server, and Secondary DNS server**. After changing network settings, make sure to uncheck the "Reset network at next boot option" to avoid the installation starting up again the next time the system restarts. Otherwise, existing network settings will be erased at the next startup.

SMTP

VPort 2310 Video Server not only plays the role of server, but also actively connects to outside servers to send alarm messages or snapshots. If the administrator has set up some applications in either event mode or sequential mode, the VPort will send out snapshots once these conditions occur.

1. To activate the e-mail function, enter correct settings for **1st SMTP (mail) server's domain name/IP address, account name/password, and 1st Recipient email address**.
2. **2nd SMTP (mail) server's domain name/IP address, account name/password, and 2nd Recipient email address** are provided for a backup connection when the 1st SMTP server fails.
3. **Sender email address** is for the address the email is returned to when the SMTP server rejects email due to a failure. Some ISPs may need the sender email address to determine if this email is valid or not, or reject the email if the address is invalid.

NOTE Note that if the **Sender email address** is not set, a warning message will pop up and the e-mail system will not be allowed to operate.

FTP

FTP is the other method available for VPort 2310 Video Server to send out alarm messages and snapshots. To send the system log files described in the above paragraph via FTP, the SMTP server should be erased.

1. **Local FTP server port** can also be changed to a setting different from the default setting of 21. Administrators should have enough network knowledge to change the default port.
2. Administrators must enter correct **Primary FTP Server**, **Primary FTP user name**, and **Primary FTP password**.
3. **Primary FTP remote folder** is the sub-folder in the remote FTP server.
4. If the remote FTP server's port is changed to a setting different from 21, make sure to set the real port to **Primary FTP server port**.
5. If the local network is protected by a firewall to prevent it from initiating an FTP connection from the remote FTP server, you may be able to connect to the FTP server, but be unable to place a file on the server due to data channel connection failure. Check **Primary FTP passive mode** for a passive transfer solution.
6. Another set of **Secondary** server settings is also provided for a backup connection.

NOTE Whenever the system reboots, a system log will be sent out via email or FTP to show the login status of VPort. The system log will be sent to the Sender email address if the SMTP server settings are correct. To send the system log via FTP, the SMTP server should be erased since the E-mail system is used by default to transmit the system log.

NOTE In either e-mail or FTP, the 1st server information should be entered first. If the 1st server is not set, the related FTP or email will be cancelled. Note that it may take time to connect to the 2nd server after the first one fails, and it may affect some applications when conditions occur too often.

HTTP

For security or network integration, administrators can hide the server from the general **HTTP port** by changing the default HTTP port of 80 to a different port number. These ports of **Control Channel Port**, **Audio Channel Port**, and **Video Channel Port** which are used in media transmission can also be changed. Administrators should have enough network knowledge to change the default port.

NOTE If the video server is behind NAT, port mapping is necessary for connections outside NAT. Totally, 4 port mappings need to be set in the NAT router to enable full video and audio streaming by video server: **HTTP port**, **control channel port**, **video channel port**, and **audio channel port**.

Audio Control

There are 2 settings for audio controlled by the administrator.

1. **Improve audio quality in a low bandwidth environment**

If the VPort works in a variable or low bandwidth (compared with video bandwidth) environment, the client side will receive poor media quality. To improve the situation, administrator can check the **Improve audio quality in low bandwidth environment** item to improve the audio quality, but the video delay will be longer, resulting in poor “real-time” quality. If the network performance is poor, users can select the **UDP protocol** as the communication protocol in **client settings**.

2. **Mute**

The administrator can disable audio streaming by checking the **Mute** box. Users connected to the VPort will only receive video. Once **Mute** is checked, LED2 for CONNECT status will blink once about every 2 seconds, which is obviously slower than the normal condition with both video and audio streaming.

Save the modification

After all necessary modifications are made, click on **Save** to store the modifications. A warning message will appear for confirmation. After clicking on **OK**, the VPort will automatically restart. If the **Reset network at next boot** option is checked, perform the software installation again. Otherwise, the VPort will boot up automatically using the new configuration settings.

<p>NOTE If you make any changes to the settings on this web page, the system will restart to validate those changes. Make sure that every field is correctly typed before clicking on Save. If the VPort fails to respond due to incorrect settings, perform the installation procedures again (as described in the beginning of Chapter 2).</p>

DDNS & UPnP

Two tools are available for administrators to link conveniently to VPort 2310. The first tool is **DDNS (Dynamic Domain Name System)**, a combination of DHCP, DNS, and client registration, all working together. DDNS allows administrators to alias VPort's dynamic IP address to a static hostname in any of the domains provided by the DDNS service providers listed in VPort's DDNS& UPnP configuration page. VPort will be easier to access from various locations on the Internet. The second tool is **UPnP (Universal Plug & Play)**, a networking architecture that provides compatibility among networking equipment, software, and peripherals of the 400+ vendors that are part of the Universal Plug and Play Forum. which means that they are listed in the network devices table for the operating system (such as Windows XP) supported by this function. Users can link to VPort directly by clicking the VPort listed in the network devices table.

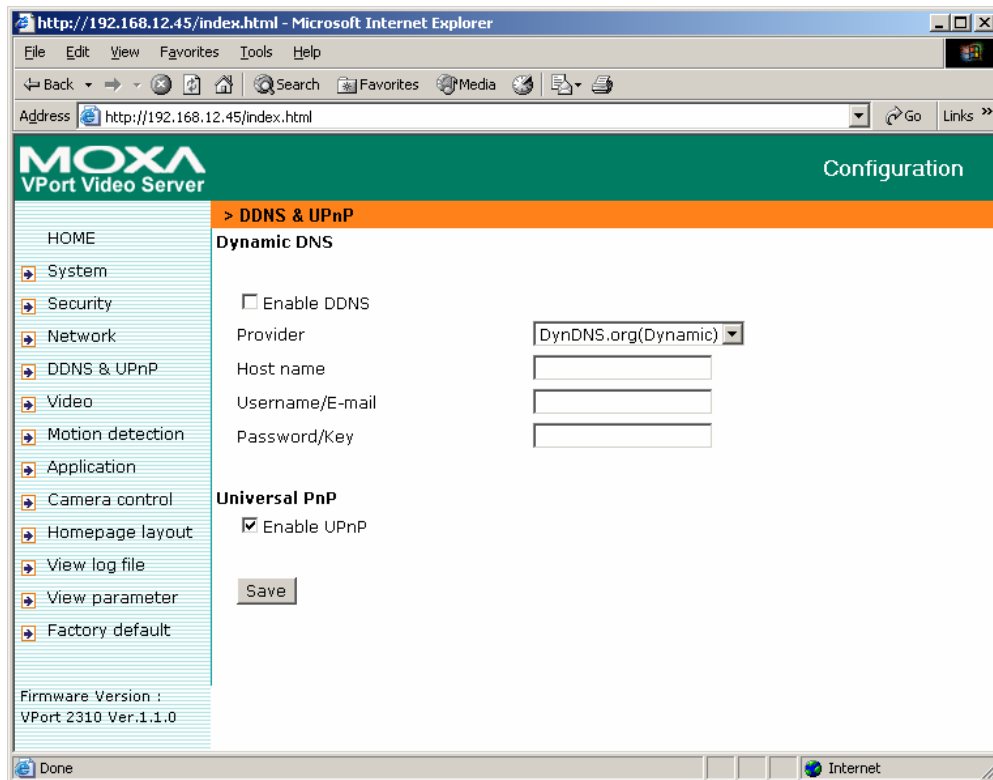

Dynamic DNS

To enable the DDNS function, the administrator should first apply for a Host Name from the DDNS service providers' website. There are 3 providers listed in VPort: DynDNS.org, TZO.com, and dhs.org. Refer to the providers' rules when enabling the function.

Step 1: Checkmark **Enable DDNS**.

Step 2: Select the DDNS service **Provider** you applied.

Step 3: Key in the **Host Name** you applied for linking to VPort.

Step 4: Key in the **Username/E-mail** and **Password/Key** to enable the service from the DDNS service provider (based on the rules of DDNS websites).

Step 5: Click save to enable the DDNS configuration of VPort

Universal PnP

Checkmark the **Enable UPnP** box, and click save to enable the UPnP function. Users will be able to find and connect to the VPort directly from the operating system's network device.

Video

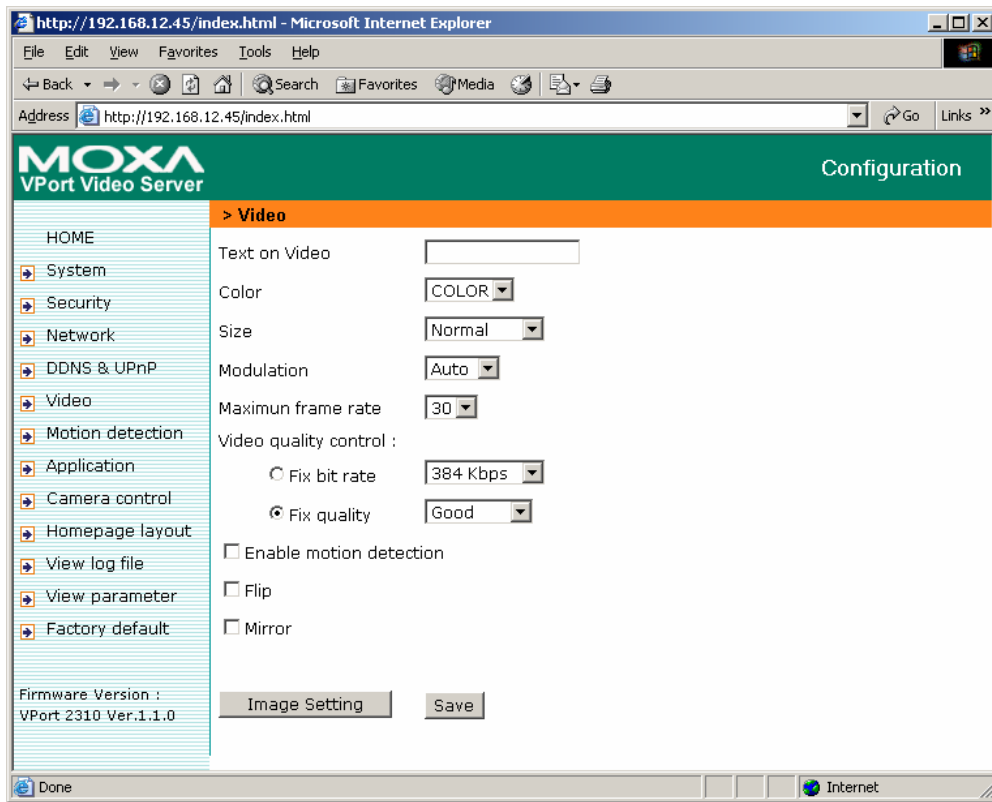

Text on Video

Administrators can specify camera information by typing text into the **Text on image** box. The text will appear on the frame above the image for reference.

Color

The **Color** setting depends on the connected camera. If the camera's image is captured in color, the administrator can decide that the image shown on VPort's webpage is in color or B/W. The "B/W" option can speed up the encoder. If the camera's image is captured in B/W, the image will only be shown in B/W.

Size

There are 5 options for selecting image sizes:

Video Size (unit: pixels)	NTSC	PAL
Half	176 × 112	176 × 112
Half × 2	352 × 240	352 × 288
Standard	352 × 240	352 × 288
Standard × 2	704 × 480	704 × 576
Double	704 × 480	704 × 576

NOTE **Half × 2** consumes the same file size and bandwidth as **Half**, but has the same resolution as **Standard**. For this reason, the visual effect of **Half × 2** is worse than **Standard**. Likewise, **Standard × 2** consumes the same file size and bandwidth as **Standard**, but has the same resolution as **Double**. For this reason, the visual effect of **Standard × 2** is worse than **Double**.

Modulation

There are 3 types of **Modulation**. Administrators can set the auto-detect condition during initialization by selecting **Auto**, but can still set it manually by selecting **NTSC** or **PAL**.

Maximum Frame Rate

Administrators can set up the maximum frame rate of the video stream manually to save bandwidth. You may choose from 8 frame rates: 1, 2, 3, 5, 10, 15, 20, 25, and 30. The maximum frame rate is determined by the **Video Size**. For example, once the video size is set to double, the maximum frame rate is only 10.

Video Size (unit: pixels)	Maximum Frame Rate
Half	30
Half × 2	30
Standard	30
Standard × 2	30
Double	10

Video Quality Control

Video Quality Control is used to optimize the bandwidth of the MPEG4 video stream. There are 2 modes for video quality control.

1. **Fixed bit rate**: the administrator can fix the bandwidth to tune the video quality and FPS (frames per second) to the optimum combination. You may choose from 7 bandwidths: **64K, 128K, 256K, 384K, 512K, 768K, 1000K, and 1200K bps**. The combination of image quality and FPS is determined by the bandwidth. For example, the FPS is slow and the quality is bad at 64 Kbps, and the quality is best at 1200 Kbps. But the FPS is about 10 due to the limitation of VPort's system resources.
2. **Fixed Quality**: the administrator can set the image quality to one of 5 standards: **Medium, Standard, Good, Detailed, and Excellent**. VPort will tune the bandwidth and FPS automatically to the optimum combination.

NOTE The default video quality control setting is **Fixed bit rate** at 384 Kbps. At this bandwidth, the image quality is good under most conditions if the FPS is near 30 and the video size is normal. But the image quality, FPS, and bandwidth are influenced significantly by the network throughput, system network bandwidth management, applications VPort runs (such as VMD), how complicated the image is, and the performance of your PC or notebook at displaying images. The administrator should take into consideration all of these variations when designing the video over IP system, and when specifying the requirements for the video system.

Enable Motion Detection

Checkmark the **Enable Motion Detection** box to enable the VMD (Video Motion Detection) function. To set up VMD, refer to the **Configuration/Motion Detection** page.

Flip and Mirror

Flip and **Mirror** are used to change what the image looks like on VPort's homepage. Checkmark the **Flip** box to flip the image about a vertical axis, and checkmark the **Mirror** box to flip the image about a horizontal axis.

Image Setting

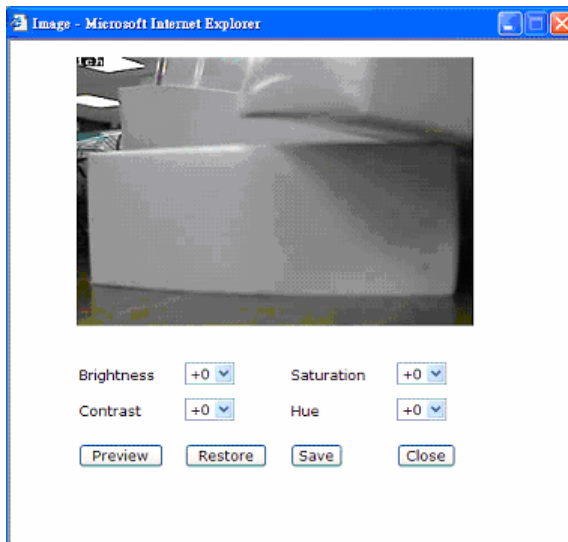

To adjust image settings for the best visual quality, click on Image Settings to open a motion picture window. Four fields need to be configured: **Brightness**, **Contrast**, **Hue**, and **Saturation**. Each field has eleven levels, ranging from -5 to +5. Click on **preview** at any time to see if the settings are appropriate before clicking on **Save**. If the adjustment is not satisfactory, click on **restore** to restore the original settings. When finished, click on **Close** to close the window. If the configuration is changed without saving, the settings will be deleted the next time the system starts up.

Save the settings

Click on the **Save** button to save the settings to the VPort. The message shown below will pop up, informing you that **If you change the modulation, the server will restart and you need to reconnect [to] the server by reloading the web page.** This means that the VPort will only restart its system if you change the camera's modulation manually. In addition, if are not using a fixed IP address, or you find that the previous IP address no longer connects to the VPort, you will need to run the installation process again to relocate the VPort's IP address.

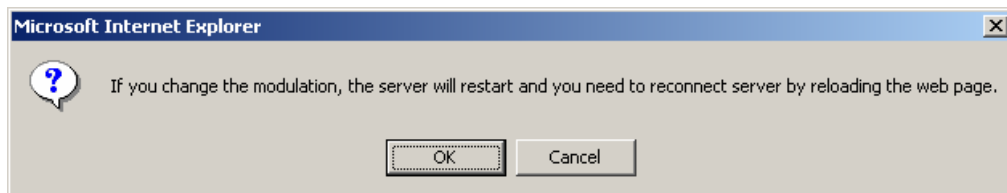

Motion Detection

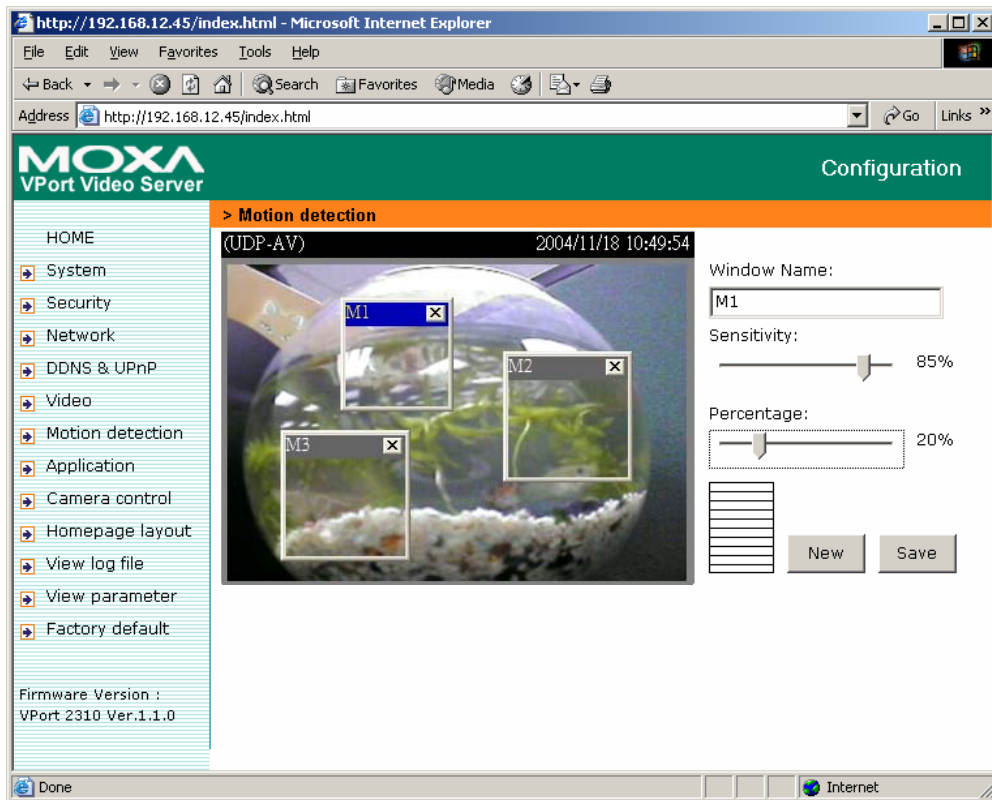

Three areas can be selected for configuring VPort 2310's VMD (video motion detection) function. The VMD alarm will only be triggered when the VMD conditions in these 3 specific areas are met. Each area can be fine tuned to fit the environment for different VMD conditions by setting **Sensitivity** and image change **Percentage**.

1. **Sensitivity** sets the measurable difference between two sequential images to indicate motion.
2. **Percentage** sets the minimum size of the image whose motion will be detected. (E.g., if Object size = 30%, then the system will only detect the motion of objects that occupy an area larger than 30% of the total monitored area; the motion of objects with size less than 30% of the monitored area will NOT be detected.)

How to Set up a VMD condition

- Step 1:** To enable VMD settings, go to the **Configuration/Video** page and checkmark the **Enable Motion Detection** box.
- Step 2:** Click the image. A VMD window will pop up. Right click the title bar of this window to move the location of the VMD window, or drag the boarder to change the window size so that it fits the desired VMD area.
- Step 3:** Use **Window Name** to assign a name to this VMD window (refer to the **Trigger Condition** in the **Configuration/Application** page).
- Step 4:** Set up the **Sensitivity** and **Percentage** parameters by moving the percentage cursor.
- Step 5:** Click on the **Save** button to save the settings.

Step 6: To test the VMD condition, check the action of the graphics bar on the left side of the save button. Wave your hand in front of the camera, in the VMD area, and then note which color shows up in the graphics bar. Green means VMD is not triggered, and Red means VMD is triggered.

Step 7: Users will see a red frame with the VMD window size in the homepage's image if the VMD is triggered.



NOTE Motion detection is provided as a reference because it is environment-dependent. When the settings are configured to be very sensitive to motion, some triggered events might actually be false alarms, since in fact there is only a tiny difference between sequential images. False alarms can be triggered by the flashing of florescent lights, shifting of shadows, etc.

Application

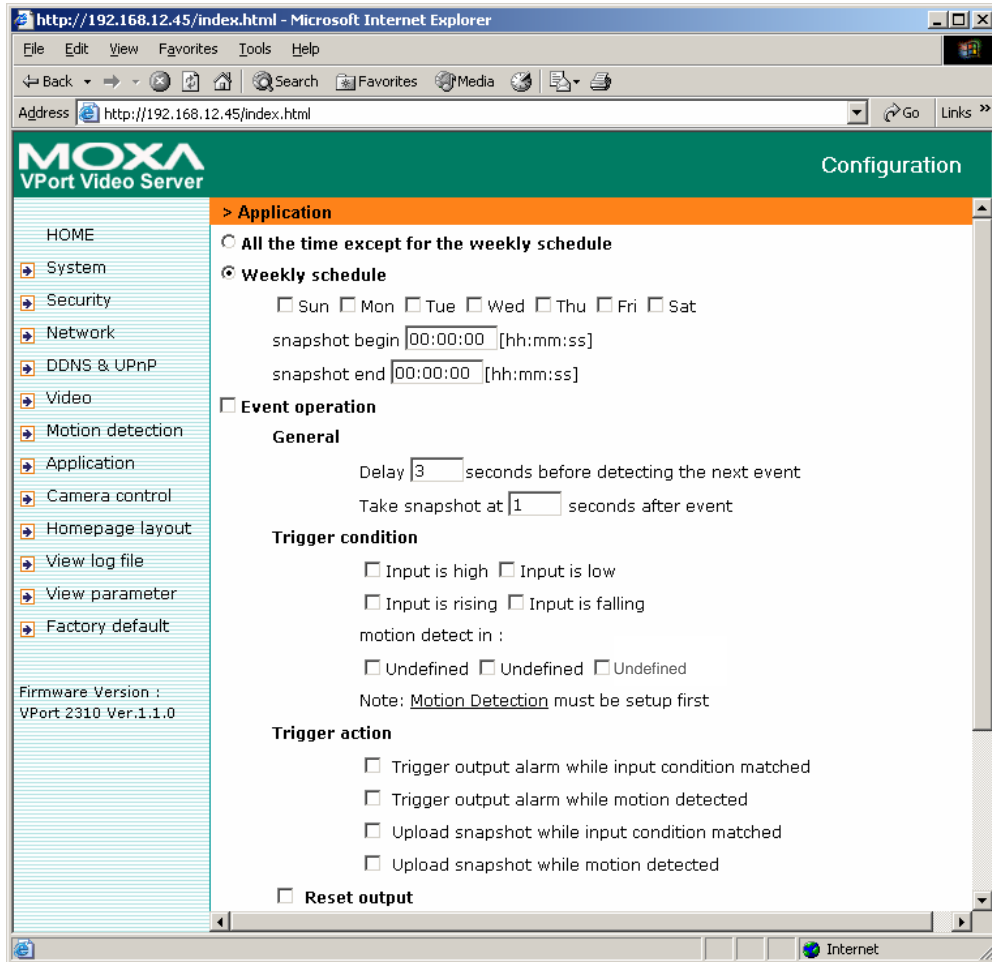

NOTE After you set up the motion detection window, the Window name will be changed from “Undefined” to the name you assigned it.

VPort 2310 Video Server provides 3 major applications.

1. **Weekly schedule:** Administrators can set up the Application schedule by weekly day and time.
2. **Event operation:** Administrators can set **Trigger Condition** by selecting DI actions or VMD options, and **Trigger Action** by selecting DO actions or Email/FTP options.
3. **Sequential Operation:** Administrators can set the sequential snapshot mode to send the snapshot by time interval.

Administrators can use combinations of options on the application web page to perform various useful security applications.

To set up the applications that VPort 2310 Video Server provides, take the following steps to setup the applications.

<p>Step 1: Choose the operation period</p>	<p><input type="radio"/> All the time except for the above schedule</p> <p><input type="radio"/> Weekly schedule</p> <p><input type="checkbox"/> Sun <input type="checkbox"/> Mon <input type="checkbox"/> Tue <input type="checkbox"/> Wed <input type="checkbox"/> Thu <input type="checkbox"/> Fri <input type="checkbox"/> Sat</p> <p>snapshot begin <input type="text" value="00:00:00"/> [hh:mm:ss]</p> <p>snapshot end <input type="text" value="00:00:00"/> [hh:mm:ss]</p>	
<p>Step 2: Choose the application</p>	<p><input type="checkbox"/> Event operation</p>	<p><input type="checkbox"/> Sequential mode</p>
<p>Step 3: Set up the application's actions</p>	<p>Step 3-1: setup the General</p> <p>Delay <input type="checkbox"/> seconds before detecting the next event</p> <p>Take snapshot at <input type="checkbox"/> seconds after event</p> <hr/> <p>Step 3-2: setup the Trigger Condition</p> <p><input type="checkbox"/> Input is high <input type="checkbox"/> Input is low</p> <p><input type="checkbox"/> Input is rising <input type="checkbox"/> Input is falling</p> <p>Motion detected in:</p> <p><input type="checkbox"/> Undefined <input type="checkbox"/> Undefined <input type="checkbox"/> Undefined</p>	

	<p>Step 3-3: setup the Trigger action</p> <p><input type="checkbox"/> Trigger output alarm while input condition matched</p> <p><input type="checkbox"/> Trigger output alarm while motion detected</p> <p><input type="checkbox"/> Upload snapshots while input condition matched</p> <p><input type="checkbox"/> Upload snapshots while motion detected</p>	
<p>Step 4:</p> <p>Choose the snapshot images sending method if you choose the upload snapshot trigger action or sequential mode</p>	<p><input type="radio"/> Send snapshot by email</p> <p><input type="radio"/> Send snapshot by FTP</p> <p><input type="checkbox"/> FTP put snapshots with date and time suffix</p>	
<p>Step 5:</p> <p>Click Save to enable the applications</p>		

Weekly schedule

The Weekly schedule is provided for daily security applications. Administrators can select any weekday from Monday to Friday with the daily schedule set from 9 am to 6 pm when no one is available to perform event checking. If the security system is installed in an office for which no one is present on nights or weekends, administrators can still set the time period as above, from 9 am to 6 pm. However, remember to select **All the time except for the above schedule** to let the program run during nights and weekends.

NOTE	Either "Weekly schedule" or "All the time except for the above schedule" must be selected, or the applications described in the following sections will not work properly.
------	--

Event operation

Event operation is for setting security applications.

1. General

- a. **Delay seconds before detecting the next event:**
The administrator can set up the time interval (in seconds, from 0 to 999) between each event's trigger action.
- b. **Take snapshot seconds after event:**
The alarm message transmitted via FTP or Email is accompanied by snapshot images. The administrator can set how much time (from 0 to 999 sec) to wait after an event is triggered to take the snapshot.

2. Trigger Condition

There are 2 trigger conditions: Video Motion Detection (VMD) and Digital Input (DI).

- a. **VMD:**
To set up the VMD trigger condition, the administrator should first configure the VMD condition on the **Configuration/Motion Detection** page (refer to the "How to set up a VMD condition" subsection earlier in this chapter), or click on the Motion Detection link to link to the **Motion Detection** page. You are allowed to set up 1, 2, or 3 motion detection windows. After you name a window, the name you selected will appear on the Application page, below "detect motion in:"

NOTE	VPort's Network and Status LEDs can be used to determine if the VPort is transmitting and receiving data over the network. Refer to Chapter 1 to see how to interpret the Network and Status LEDs.
------	--

- b. **DI:**
There are 4 Digit Input statuses, including **Input is High**, **Input is Low**, **Input is Rising**, and **Input is Falling**. An edge trigger (e.g., Rising or Falling) is generally used to detect the emerging signal from the external sensor.

3. Trigger Action

Once an event occurs, administrators can set up the trigger action after the event occurs and/or send snapshots that are taken right at the moment. There are 2 trigger actions: **Trigger output alarm** and **Upload snapshot**

- a. **Trigger output alarm.**
Administrators can set the trigger output alarm when the DI or Video Motion Detection conditions are met. Check the box of the listed action to enable the triggered output alarm.
- b. **Upload snapshot.** Administrators can set the upload snapshot action when the DI or Video Motion Detection conditions are met.

NOTE VPort 2310 Video Server will take 3 JPEG snapshot images: VPRE.JPG (pre-event), VTRG.JPG (the moment of event) and VPOS.JPG (post-event) for the video channel when the trigger condition is met. Three snapshots of the channel can also be downloaded via FTP or HTTP URL (refer to the "Download Event-triggered Snapshots" section from Chapter 5 for more details).

- c. **Reset output.** When the digital output alarm is triggered, administrators can check this **Reset output** option, and then click on **Save** to reset the digital output status.

Sequential Mode

With this feature, VPort 2310 Video Server can upload snapshots periodically to an external E-mail or FTP server as a live video source. The interval can be set to anywhere from a tenth of a second to several hours, with **Snapshot every** **seconds**. The external E-mail or FTP server must be set up in the Network configuration page.

Send Snapshot by Email or FTP

Snapshots taken by either event operation or sequential mode, which are set in the Network configuration page, can be sent by **E-mail** or **FTP**. If **E-mail** is chosen, the snapshots of the video channel will be attached to the emails. If **FTP** is chosen, administrators can choose to add date and time in the file name of the snapshots by checking **FTP put snapshots with date and time suffix**. If the snapshots are used as the live video source, the date and time suffix can be eliminated to update the same source file.

NOTE In Sequential mode, the VPort will send out snapshots according to time interval settings. If snapshot files are intended for quick updates, it is better to skip the date and time suffix, in which case the file name will be video.jpg. If the snapshots are used for occasional monitoring, suffixing with date and time can help administrators easily classify the snapshots.

NOTE Compared to the FTP method, email will induce more delay, although email can notify users more promptly.

Camera Control

VPort 2310 supports PTZ (PAN/TILT/ZOOM) motorized camera control via an RS-232 or RS-485 COM port. Before setting up camera control, the administrator should first connect the PTZ camera to the VPort.

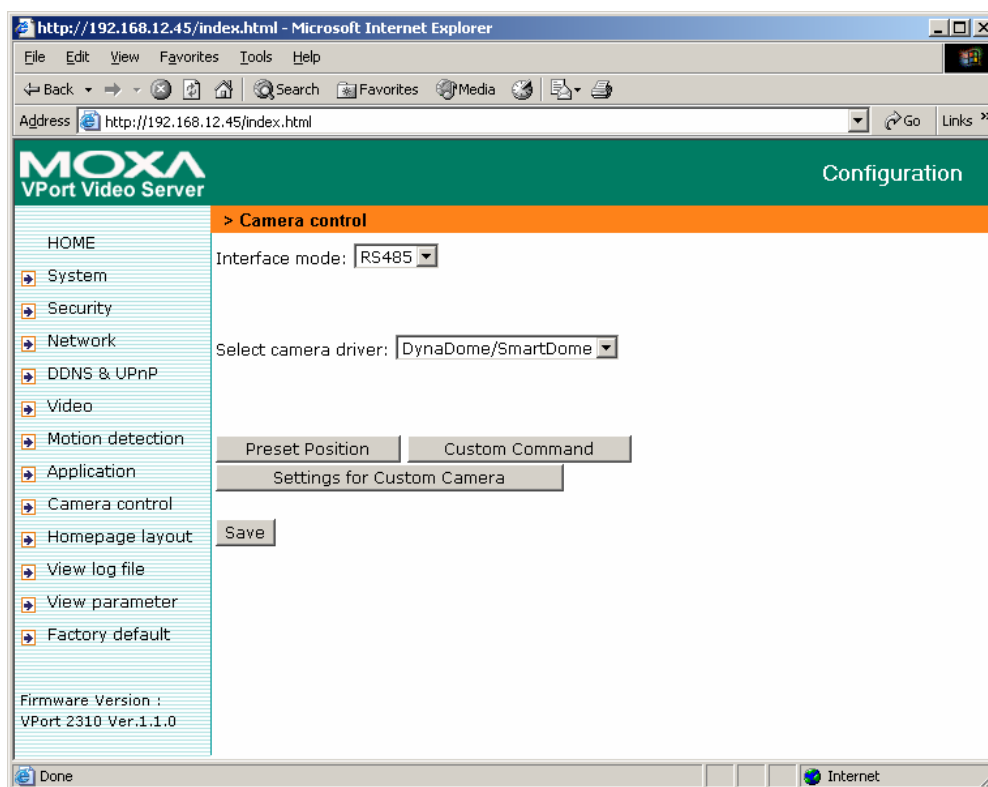

Interface mode

The COM port supports 2 serial interfaces, although only one interface can be used at a time. Depending on the interface used by the attached device, administrators must set the **Interface mode** to either RS-232 or RS-485.

NOTE The RS-232 interface is used via the DB9 COM port, and RS-485 interface is used via the GPIO. These 2 interfaces cannot be used at the same time.

Baud rate (bps)

The administrator should set the baud rate to the baud rate specified by the PTZ camera's serial communication specs.

Select Camera driver

Administrators must select the correct PTZ model under PTZ driver options, since each PTZ camera has its own protocols for the PTZ functions. Refer to Appendix B, **Settings for Supported PTZ Cameras**, to see the PTZ cameras that Moxa VPort 2310 Video Server supports. If the attached PTZ camera is not supported by the VPort, administrators can select Custom Camera to enter the proprietary commands for pan, tilt, zoom, and focus control.

Preset Position

Administrators can use the **Preset Position** function to set up the behavior of the PTZ camera in advance, and then users with the camera control privilege can directly move the camera's lens to the preset position without the need to control the pan, tilt, and zoom buttons on VPort 2310's homepage.

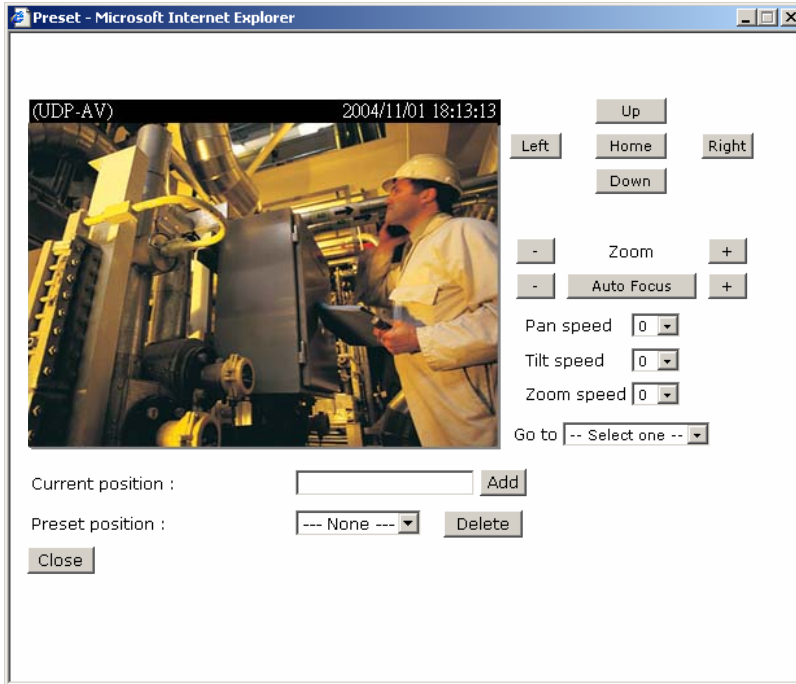

Custom commands

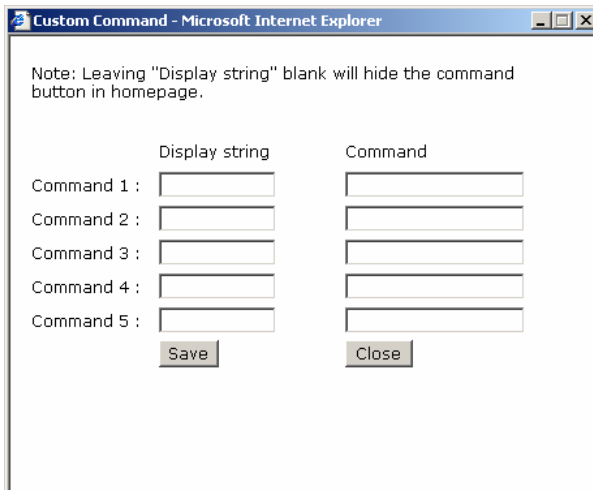

VPort 2310 Video Server provides 5 custom commands in addition to the general pan, tilt, zoom, and preset functions. Administrators can click on **Custom Command** to configure, and refer to the manual enclosed with the attached PTZ camera to set up frequently-used functions. The Command should be entered in ASCII format. The VPort will translate the commands into binary code and send them out through the serial port. For instance, a text string of **8101ABCDEF** will be translated into five bytes of hexadecimal **81**, **01**, **AB**, **CD**, and **EF**. The maximum length of a

command string is 60, which is equivalent to 30 hexadecimal bytes. The **Display string** is for the text on the command buttons and should be less than 8 characters. If **Custom Camera** is selected, there will be more commands for PTZF that relate to custom camera.

Custom Camera Settings

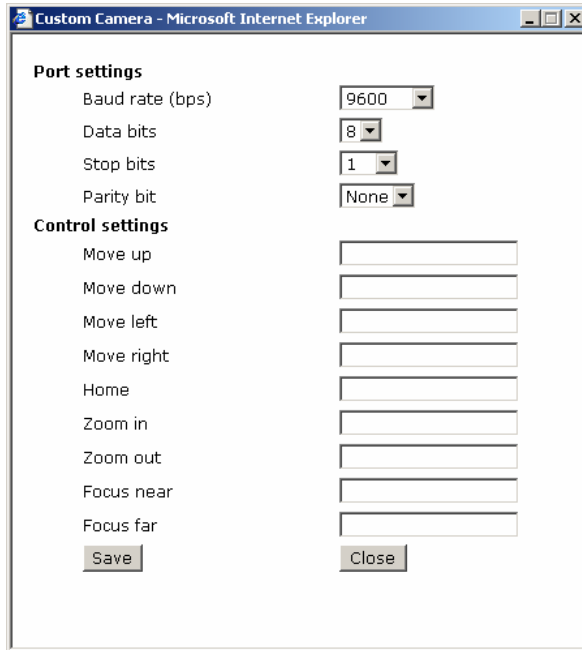

If the PTZ camera's driver is not in the list, the administrator can select the custom camera from the **Select Camera driver** menu to program the PTZ camera with ASCII code. A custom camera window will pop up when the **Setting for Custom Camera** button is clicked. Input the ASCII code into this window. **Port Settings (Data bits, Stop bits and Parity bits)** are for the serial communication parameters and **Control Settings** are for programming the **TILT (Move Up, Move Down)**, **PAN (Move Left, Move right)**, **HOME**, **ZOOM (Zoom in, Zoom out)** and **FOCUS (Focus near, Focus Far)** actions.

NOTE Get the control protocols from the PTZ camera's supplier before programming the PTZ camera.

Homepage Layout

VPort 2310 Video Server allows administrators to customize the layout of the Video Server's homepage.

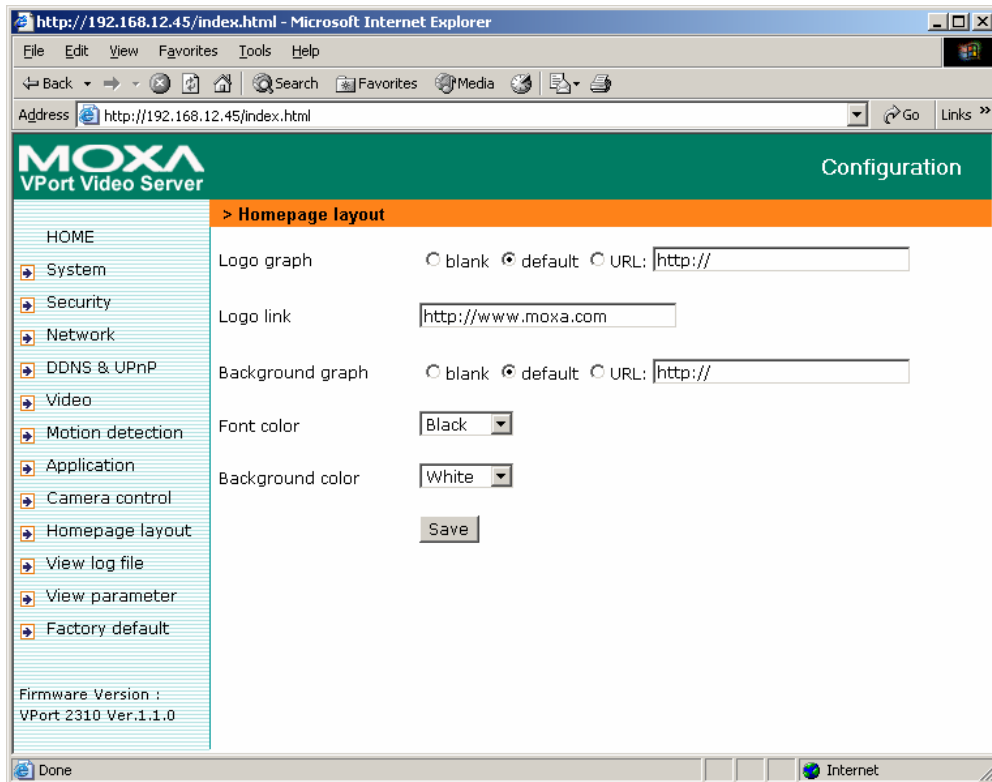

Logo figure

1. Select the blank option to hide the logo that appears in the upper-left corner of the homepage.
2. The “default” logo is the Moxa logo.
3. An external logo or image can be used by selecting the **URL** option, and typing the url for the image in the text input box.

Logo link

Administrators set up the Logo with a **Logo link**, so that visitors are directed to another web address when they click on the logo.

Background graph

As with **Logo graph**, **Background graph** gives administrators the ability to customize the background as **blank**, **default**, or an external image, by selecting the **URL** option, and then typing the url for the image in the text input box.

Font and Background color

The **Font color** and **Background color** can be chosen from sixteen custom colors.

NOTE The **Background color** option is active only when **Background graph** is set as **blank**.

View log file

The system log contains useful information, including current system configuration and activity history with timestamp for tracking.

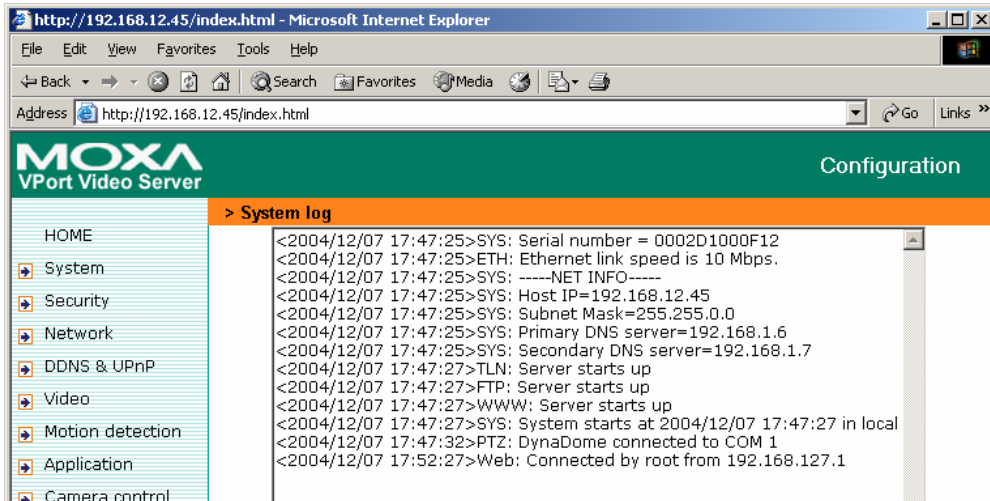

View parameters

Clicking on "View parameters" allows you to view all system parameters, which are listed by category. The content is the same as VPort 2310 Video Server's CONFIG.INI file.

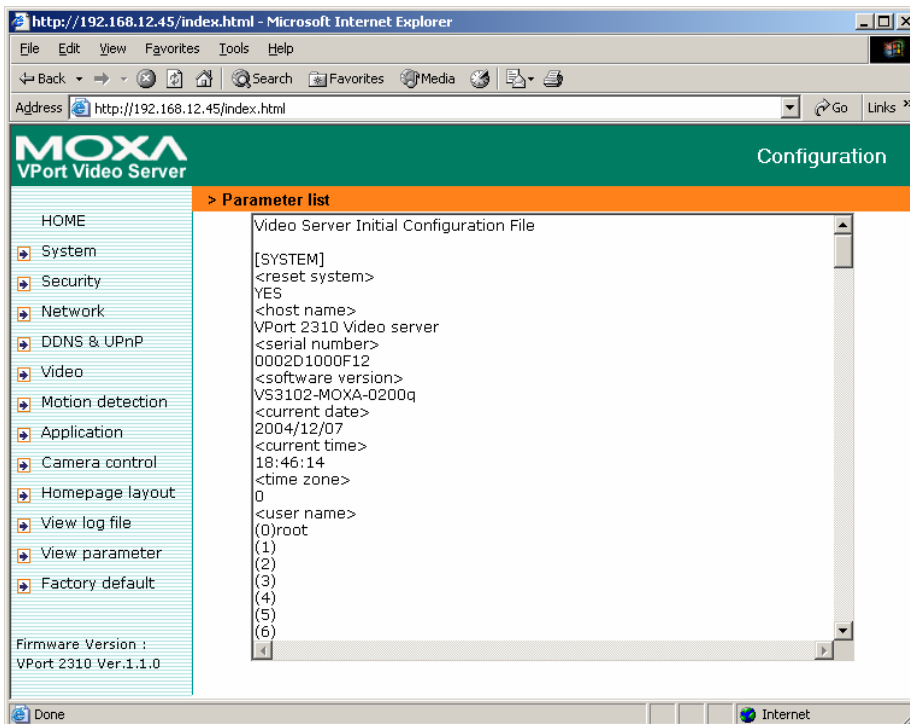

Factory default

This function is used to restore the Video Server to its factory default settings, so that any changes that were made previously will be lost. After clicking **OK**, the system will restart. Note that it will take some time for the restore action to finish. You will need to run the software installation program to set up the network.

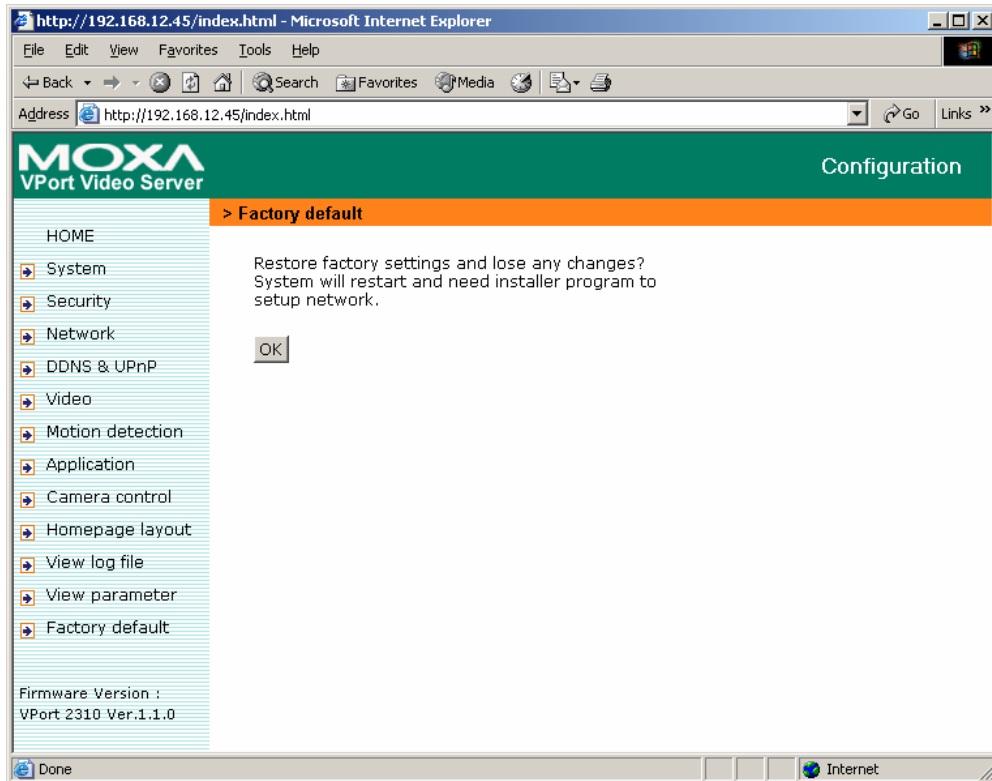

System Configuration via FTP

CONFIG.INI

FTP can be used to configure VPort 2310 Video Server much more quickly than configuring from web browser, particularly when configuring multiple Video Servers. To configure a Video Server via FTP, first download the parameter file, CONFIG.INI, customize each field, and then upload the file to the Video Server to install the new settings. To log into the FTP daemon, enter "root" as the user name, and use the same password used when connecting to the Web server. The MAC address (no dashes, all upper case) of FTP Server is the default password.

The CONFIG.INI file has eight categories: **[SYSTEM]**, **[LAYOUT]**, **[NETWORK]**, **[VIDEO]**, **[SERIAL]**, **[ALERT]**, and **[DEMO]**. The category names in square brackets should be in upper case. The item names in angle braces should be in lower case. Some items related to disable/enable should use the keywords "YES"/"NO". The number zero (0) entered in <user name> and <user password> is for administrators, i.e. "root". Video Server will restart automatically as soon as the file is uploaded and accepted. If administrators want to cancel the reboot procedure after transferring config.ini via FTP, then set the first item, <reset system>, to NO. But it will take effect only once, and show YES in the download config.ini file the next time.

A sample CONFIG.INI is shown in the table below. The text in *italics* describes the characteristics of the field, and the ***bold italic characters*** are the options for the field.

Video Server Initial Configuration file	
[SYSTEM]	
<reset system>	
YES	<i>or NO</i>
<host name>	
VPort 2310 Video Server	<i>string with maximum of 40 characters</i>
<serial number>	
0002D1005689	<i>read-only</i>
<software version>	
VS3102-Moxa-0200t	<i>read-only</i>
<current date>	
2004/11/01	<i>read-only</i>
<current time>	
12:34:56	<i>read-only</i>
<time zone>	
0	<i>from 12 to -12, GMT + Value</i>
<user name>	
(0)root	<i>read-only</i>
(1)	<i>string with maximum of 16 characters</i>
(2)	<i>the rest are the same as above</i>
(3)	
(4)	
(5)	
(6)	
(7)	
(8)	
(9)	
(10)	
(11)	
(12)	
(13)	
(14)	
(15)	
(16)	
(17)	
(18)	
(19)	
(20)	
(21) Demo	
<user password>	
(0)0002D1000972	<i>string with maximum of 16 characters</i>
(1)	<i>the rest are the same as above</i>
(2)	
(3)	
(4)	
(5)	
(6)	
(7)	
(8)	

(9)	
(10)	
(11)	
(12)	
(13)	
(14)	
(15)	
(16)	
(17)	
(18)	
(19)	
(20)	
(21)	
<language>	
en	<i>Current Language, read-only</i>
<ptzenabled>	
0	<i>read-only</i>
<NTP Update Interval>	
0	<i>0-Hourly, 1-daily, 2-weekly, 3-monthly</i>
[LAYOUT]	
	<i>0-black, 1-white, 2-green, 3-maroon, 4-olive, 5-navy, 6-purple, 7-gray, 8-yellow,</i>
1	<i>9-lime, 10-aqua, 11-fuchsia, 12-silver,</i>
<background color>	<i>13-red, 14-blue, 15-teal,</i>
0	
<logo type>	
1	<i>default image, or 0 for blank, or 2 from URL</i>
<background type>	
1	<i>default image, or 0 for blank, or 2 from URL</i>
<logo source>	
http://	<i>URL of logo type 2, maximum of 80 characters</i>
<background source>	
http://	<i>URL of logo type 2, maximum of 80 characters</i>
<logo link>	
http://	<i>reference link of logo, max. of 80 characters</i>
<com speedlink name>	<i>Name of custom PTZ commands</i>
(0)	<i>string with maximum of 8 characters</i>
(1)	<i>string with maximum of 8 characters</i>
(2)	<i>string with maximum of 8 characters</i>
(3)	<i>string with maximum of 8 characters</i>
(4)	<i>string with maximum of 8 characters</i>
[NETWORK]	
<install enabled>	
YES	<i>reset IP whenever system boots or NO</i>
<ppp enabled>	
YES	<i>obsolete</i>
<ethernet address>	
00-02-D1-00-56-89	<i>read-only</i>
<host ip>	

192.168.0.207	<i>standard IP format</i>
<subnet mask>	
255.255.255.0	<i>standard IP format</i>
<gateway ip>	
0.0.0.0	<i>standard IP format</i>
<primary name server>	
0.0.0.0	<i>standard IP format</i>
<secondary name server>	
0.0.0.0	<i>standard IP format</i>
<ntp enabled>	
NO	<i>or YES</i>
<network timing server>	
	<i>IP address or domain name</i>
<smtp mail server>	
	<i>IP address or domain name</i>
<SMTP account name 1>	
	<i>string of maximum 63 characters</i>
<SMTP password 1>	
	<i>string of maximum 15 characters</i>
<mail recipient address>	
	<i>string with maximum of 80 characters</i>
<mail return address>	
VPort 2310 Video Server	<i>string with maximum of 80 characters</i>
<backup smtp mail server>	
	<i>IP address or domain name</i>
<SMTP account name 2>	
	<i>string of maximum 63 characters</i>
<SMTP password 2>	
	<i>string of maximum 15 characters</i>
<backup mail recipient address>	
	<i>string with maximum of 80 characters</i>
<local ftp port>	
21	<i>or 1024 to 65535</i>
<ftp server>	
	<i>IP address or domain name</i>
<ftp port>	
21	<i>or 1024 to 65535</i>
<ftp username>	
	<i>string with maximum of 16 characters</i>
<ftp password>	
	<i>string with maximum of 16 characters</i>
<ftp init path>	
	<i>string with maximum of 40 characters</i>
<ftp passive>	
NO	<i>or YES</i>
<backup ftp server>	
	<i>IP address or domain name</i>
<backup ftp port>	
21	<i>or 1024 to 65535</i>
<backup ftp username>	
	<i>string with maximum of 14 characters</i>

<backup ftp password>	
	<i>string with maximum of 14 characters</i>
<backup ftp init path>	
	<i>string with maximum of 40 characters</i>
<backup ftp passive>	
NO	<i>or YES</i>
<http server port>	
80	<i>or 1024 to 65535</i>
<control channel port>	
5001	<i>1024 to 65535</i>
<audio channel port>	
5002	<i>1024 to 65535</i>
<video channel port>	
5003	<i>1024 to 65535</i>
<low bandwidth environment>	
0	<i>or YES, Improve audio quality in low bandwidth environment</i>
<mute>	
0	<i>or YES</i>
[DDNS]	
<enable>	
0	
<provider>	
0	<i>1-DynDNS.org(Dyanamic), 2-DynDNS.org(Custom) 3-TZO.com, 4-dhs.org</i>
<hostname>	
	<i>IP address or domain name</i>
<username/email>	
	<i>string of maximum 63 characters</i>
<password/key>	
	<i>string of maximum 21 characters</i>
[UPNP]	
<enable>	
Yes	<i>or NO</i>
[VIDEO]	
<camera modulation>	
AUTO	<i>or MANUAL. NTSC or PAL will be ignored when set to AUTO</i>
NTSC	<i>or PAL, ignored when set to AUTO but can be notification</i>
<caption text>	
	<i>string of maximum 16 characters</i>
<colored video>	
YES	<i>or NO for monochrome</i>
<video quality>	
8	<i>4-excellect, 6-good, 8-normal, 10-rough, 12-bad</i>

<brightness>	
0	<i>between 5 and -5</i>
<contrast>	
0	<i>between 5 and -5</i>
<hue>	
0	<i>between 5 and -5</i>
<saturation>	
0	<i>between 5 and -5</i>
<rate control>	
YES	<i>or NO</i>
<bit rate>	
384K	<i>values:64k, 128k, 256k, 384k, 512k, 768k, 1000k, 1200k</i>
<frame rate>	
30	<i>values:1, 2, 3, 5, 10, 15, 20, 25, 30</i>
<video size>	
1	<i>Half, 2-Halfx2, 3-Normal, 4-Normalx2, 5-Double</i>
<motion detect enabled>	
YES	<i>or NO</i>
<flip>	
NO	<i>or YES</i>
<mirror>	
NO	<i>or YES</i>
[SERIAL]	
<auto detect camera>	
NO	<i>or YES</i>
<data bits>	
0	
<stop bits>	
0	
<parity bits>	
0	<i>None, 1 for Odd, 2 for Even</i>
<baud rate>	
0	
<ccd model>	
0	<i>None, 1 for Custom Camera, 2 for Sony VISCA, 3 for Canon VC-C1, 4 for Canon VC-C3, 5 for Canon VC-C4, 6 for DynaDome, 7 for Pelco D, 8 for LiLin</i>
<uart mode>	
RS232	<i>or RS485</i>
<speedlink commands>	
(0)	<i>string of maximum 60 characters</i>
(1)	<i>string of maximum 60 characters</i>
(2)	<i>string of maximum 60 characters</i>
(3)	<i>string of maximum 60 characters</i>
(4)	<i>string of maximum 60characters</i>
<custom ccd commands>	
HOME	
	<i>string with maximum of 60 characters</i>

UP	
	<i>string with maximum of 60 characters</i>
DOWN	
	<i>string with maximum of 60 characters</i>
LEFT	
	<i>string with maximum of 60 characters</i>
RIGHT	
	<i>string with maximum of 60 characters</i>
TELESCOPE	
	<i>string with maximum of 60 characters</i>
WIDE	
	<i>string with maximum of 60 characters</i>
NEAR	
	<i>string with maximum of 60 characters</i>
FAR	
	<i>string with maximum of 60 characters</i>
[ALERT]	
<application mode >	
0	<i>disabled, 1 for Sequential, 10 for motion detection event, 12 for DI event</i>
<upload method>	
0	<i>FTP, 1 for email</i>
<file with time suffix>	
YES	<i>or NO</i>
<seconds to snapshot after event>	
0	0 ~ 999
<seconds delay before next event>	
0	0 ~ 999
<seconds to snapshot periodically>	
0	0 ~ 999
<time to start snapshot>	
00:00:00	<i>24 hours format</i>
<time to stop snapshot>	
00:00:00	<i>24 hours format</i>
[FEATURE]	
<event>	
1	

System Configuration Via Telnet

Telnet Commands

Video Server has a Telnet daemon that allows administrators to access some seldom used functions. Using any general terminal program to connect to Video Server will prompt the user for a password. The Username is not requested since only administrators can access the Telnet daemon. The password is the same as that used for web access. After logging in, type "help" for the command list. If "debug" or "dinote" is not executed, Telnet will disconnect automatically after being idle for 1 minute.

System core debugging

General activities are recorded into SYSTEM.LOG continuously, but information about abnormal status is not recorded. Administrators can type the "debug" command to examine in-depth core debugging information. This causes Video Server to start dumping the detailed debugging information while the system is running. This is useful for examining if any errors have occurred when the system operates abnormally. The stored information will be cleared automatically after the dump. Video Server will continue to dump new messages unless the connection is broken. If Telnet is not connected, messages will be stored until administrators re-login.

Monitoring changes to digital input status

Typing "dinote" will make Video Server send the current status of all digital inputs. After that, Video Server will continuously monitor DI status and send messages only when the state has changed. For example, after typing "dinote" the terminal will display

```
DI=L
```

and after DI1 changes to H, the terminal will display

```
DI=H
```

Stop information dumping

Typing "stop" will halt the dumping of debug information and the digital input status.

Query status of digital inputs

Typing "diquery" will display the status of all digital inputs once.

Set digital outputs

To set digital output to connect NO with COMMON, type "DO=L".

To set digital output to connect NC with COMMON, type "DO=H".

Erase snapshots stored in Flash memory

Typing "erase image" will clear all snapshots saved in Flash memory.

Skip installation at next boot

Typing "lock" will inform Video Server to lock the current network settings. You won't need to go through the installation procedure the next time the Video Server boots up.

Erase logo and graphic buttons

Typing “erase graph” will clear all images used on the homepage. If no new images are uploaded, the system will switch to text mode and use default images instead.

Reset network

Typing “unlock” will cause Video Server to wait for the installation procedure the next time it boots up.

Restore factory default settings

Typing “clear” will make Video Server restore factory settings but not restart. To validate new settings, type “reset” to make the system restart.

Reset system

Typing “reset” will make Video Server perform a software reset.

Advanced Applications

This chapter will introduce more advanced applications.

The following topics are covered in this chapter:

- ❑ **Capturing Up-to-date Still Images**
 - Getting snapshot via URL
 - Getting snapshot via FTP
- ❑ **Video Embedded in Customers' Homepage**
- ❑ **Download Event-triggered Snapshots**
 - Getting triggered snapshots via URL
 - Getting triggered snapshots via FTP
- ❑ **Customizing Homepage Graphics**
- ❑ **URL Commands for DI/DO & Camera's Actions Setting**
 - Query status of digital inputs
 - Drive digital outputs
 - Moving motorized camera in PTZ direction
 - Recalling camera position
 - Transparent Remote Serial Driver
 - Sending commands to devices attached to the COM port
- ❑ **URL Commands for System Maintenance**
 - Download System Log via FTP
 - Restart System via URL
 - Restore Factory Default Settings via URL

Capturing Up-to-date Still Images

Getting snapshot via URL

Administrators and users can use a specific URL to capture the current still image.

URL
<code>http://<IP of Video Server>/cgi-bin/video.jpg</code>

Getting snapshot via FTP

Administrators and users can log in to the Video Server FTP daemon to download the refreshed JPEG image named **video.jpg**. The user name and password are the same as for web access. The zero file size in the file directory means it is captured by request.

Video Embedded in Customers' Homepage

In addition to the URL, some scripts should be added to download a plug-in for video images. The following example simply displays title text and a real-time video window in Internet Explorer or Netscape. The user name and password should be configured in advance. Those who are familiar with HTML can easily add more components or rewrite the code to create a more vivid and useful homepage.

```

<tr><td height=5>&nbsp;&nbsp;&nbsp;</td></tr>
<tr><td align=center>
<script language="JavaScript">
<!--
if ((navigator.appName == "Microsoft Internet
Explorer")&&(navigator.platform != "MacPPC"))
{
document.write("<OBJECT ID=\"VAMCtrl\" WIDTH=362 HEIGHT=306");
document.write("
CLASSID=CLSID:A93B47FD-9BF6-4DA8-97FC-9270B9D64A6C");
document.write("
CODEBASE=\"/plugin/h263ctrl.cab#version=1,8,0,5\">");
document.write("<PARAM NAME=\"DigitalZoomEdit\" VALUE=\"true\">");
document.write("<PARAM NAME=\"EnableVolumeControl\"
VALUE=\"false\">");
document.write("<PARAM NAME=\"Deblocking\" VALUE=\"true\">");
document.write("<PARAM NAME=\"Url\"
VALUE=\"http://username:password@192.168.0.100/cgi-bin/video.vam\">");
document.write("<PARAM NAME=\"VSize\" VALUE=\"SIF\">");
document.write("<PARAM NAME=\"Language\" VALUE=\"EN\">");
document.write("</OBJECT>");
}
//-->
</script>
</td></tr>

```

NOTE	The camera's image will not be visible when using IE6.0 Security Package Update (MS04-004), since it will block VPort's username and password on a customized homepage. You may need to disable VPort password protection, or check the patch description of IE (No. 832894) to solve this problem.
-------------	---

Download Event-triggered Snapshots

There are three video image files for the video channel of three stages: pre-alarm, the moment when triggered, and post-alarm. Only the snapshots captured by the last event are preserved. Administrator and users can use FTP or URL to get the saved snapshots. They can also be browsed from the application page under system configuration.

Getting triggered snapshots via URL

/cgi-bin/snapshot.jpg?file=<value>

Video channel \ Snapshot stage	Value
snapshot before event	Pre
snapshot upon event	trg
snapshot after event	pos

Getting triggered snapshots via FTP

File name	Pre-alarm	Upon alarm	Post-alarm
Video	vpre.jpg	vtrg.jpg	vpos.jpg

Customizing Homepage Graphics

The small icon before each link can be changed by the Administrator. There are three types of logos and backgrounds: blank, default, and other URL. The default method will use the image stored in the Flash memory. The administrator may change the default logo, background image, and button images by uploading customized ones. The following table shows the referenced file names and size limitations.

Object	File name	Maximal size
Logo	logo.gif	Logo and background share 8000 bytes
Background	back.gif	Logo and background share 8000 bytes
Link icon	btn_text.gif	2000 bytes

Usage via FTP is illustrated below.

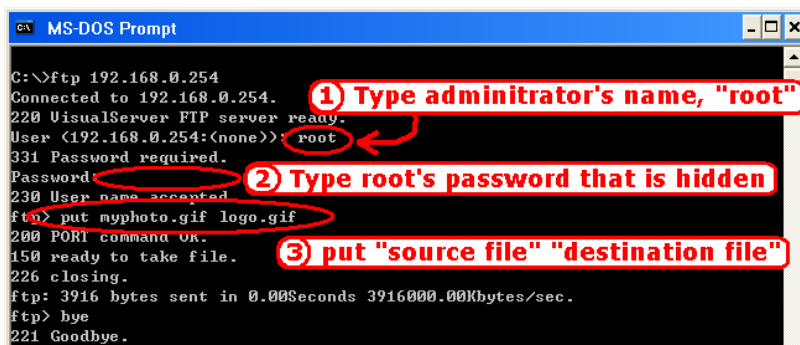

URL Commands for DI/DO & Camera's Actions Setting

Query status of digital inputs

```
/setup/getdi.cgi
```

Video Server will return status of four digital inputs in one line.

Drive digital outputs

```
/setup/setdo.cgi?do=<state>
```

Where state is H, L. H means NC connected with COMMON and L means NO connected with COMMON.

For example, <http://192.168.0.201/setup/setdo.cgi?do=h> will command the Video Server, with IP address of 192.168.0.201, to set digital output to connect to NC with COMMON.

Moving motorized camera in PTZ direction

<Direction>: up, left, right, down, home

<Vision>: wide, tele, near, far, auto

<Command>: 1, 2, 3, 4, 5

```
/cgi-bin/camctrl.cgi?Move=<direction>&zoom=<vision>&cust=<command>
```

Param	Value	Description
move	up	Tilt up
	down	Tilt down
	left	Pan left
	right	Pan right
	home	Return to home position
zoom	wide	Zoom in
	tele	Zoom out
	auto	Automatic focus
focus	near	Focus near
	far	Focus far
	auto	Automatic focus
panspeed	-5 to 5	
tiltspeed	-5 to 5	

Recalling camera position

```
/cgi-bin/recall.cgi?recall=<position>
```

<position>: the text string of a location that is preset in system configuration.

Refer to Camera preset configuration URL for preset function.

Transparent Remote Serial Driver

Video Server provides highly customized control support for third-party serial interface devices (other than PTZ cameras). This means that in addition to setting up a custom camera with PAN/TILT/ZOOM/FOCUS commands, users may utilize this mode and introduce a customized homepage to transmit arbitrary user-defined commands from user-side to Video Server. The third-party device connected to the serial port of Video Server will receive the same command sent

by the originator. The user only needs to attach the command in ASCII format after the special URL. The Video Server will parse the commands and translate into binary code to send out.

Sending commands to devices attached to the COM port

This URL applies to the attached serial port device including supported PTZ cameras or non-supported custom camera. Note that the serial port settings of custom cameras must be correctly defined in advance.

`/cgi-bin/senddata.cgi?data=123456,ABCDEF&flush=yes&wait=1000&read=6`

This hyperlink will inform Video Server to send out binary format commands to the COM with "0x12, 0x34, 0x56" followed by "0xAB, 0xCD, 0xEF". Each comma separates the commands by 200 milliseconds. "Flush=yes" means the receive data buffer of the COM port must be cleared before read. Then read 6 bytes after waiting for 1000 milliseconds. The read data can be up to 128 bytes and will return as ASCII coded hexadecimal value, e.g., 0x41, 0x42, 0x43 read from COM port will show in returned homepage as 414243 instead of ABC.

URL Commands for System Maintenance

Download System Log via FTP

Besides viewing the system log from the web page, administrators can download the system log file, SYSTEM.LOG, via FTP. To log into the FTP daemon, enter "root" as the user name and the same administrator's password used in Web access.

Restart System via URL

`/setup/reset.cgi`

Restart Video Server without warning.

Restore Factory Default Settings via URL

`/setup/restore.cgi`

Video Server will automatically restart after restoring factory default configurations.

6

Upgrading System Firmware

Customers can check the appropriate product page on Moxa's website to download the latest firmware. Only administrators can upgrade the system firmware of Video Server.

The following topics are covered in this chapter:

- ❑ **Using Upgrade Wizard to Upgrade Firmware**
- ❑ **Using FTP to Upgrade Firmware**

Using Upgrade Wizard to Upgrade Firmware

Step 1: Run the Upgrade Wizard (.exe) included in the product CD.

Step 2: Type the web address of the Video Server whose firmware you want to upgrade, and then type the administrator password. Click on **Next** to proceed.



Step 3: The program will detect the Video Server.



If the password is incorrect, a window will appear asking you to recheck the FTP port and password.

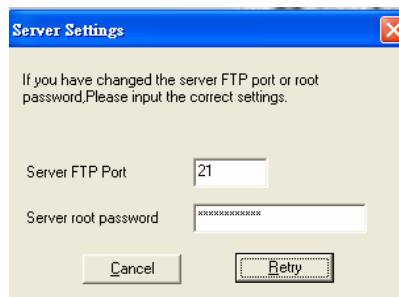

Step 4: After the Video Server has been detected, select the firmware (Flash.bin) to process the upgrade.

Step 5: Wait a few seconds for the upgrade process to finish.

Step 6: The following message appears once the firmware has been upgraded successfully.



NOTE The power supply of VPort 2310 Video Server should not be turned off when the Upgrade Wizard is upgrading the firmware. Otherwise, the firmware upgrade will fail, and you will need to return the video server to Moxa for repair.

Using FTP to Upgrade Firmware

Step 1: Use the FTP program and change the working directory to the local folder where FLASH.BIN resides.

Step 2: Connect to Video Server with user name “root” and password.

Step 3: Use the PUT command to upload FLASH.BIN to the Video Server. The file size is almost 1.5 MB. It will take approximately 2 seconds over a local network, but the actual time will depend on the status of the user's network.

Step 4: After the upload is complete, close the connection.

If the received FLASH.BIN is checked without error, the Video Server will update the software to the Flash memory and restart automatically. When the Video Server starts writing the firmware, both status LED indicators will remain lit until the system restarts (this takes about 30 to 40 seconds). You must keep the power stable during the update process. After the system restarts, the Video Server may need to be re-installed, depending on whether the **Reset network at next boot** option is enabled or not. After the Video Server boots up, reload the web page in the browser.

NOTE We strongly recommend that you use the upgrade wizard to upgrade the firmware for a Microsoft Operating System, since if the power fails during the software upgrade, the program in the memory of Video Server may be destroyed permanently. If Video Server cannot restart properly, ask the dealer for technical service.

NOTE For customizing your VPort's settings, we strongly recommend that you download config.ini via FTP before you upgrade the firmware. The risk is that once the firmware has been upgraded, the settings in config.ini might be restored to the initial settings. For this reason, after the firmware is upgraded, you need to upload the config.ini and overwrite the one existing in your VPort. By doing this, you won't need to re-configure your VPort's.

7

Troubleshooting

This chapter describes some problems that might occur during installation or operation, and provides the basic solutions to those problems.

The following topics are covered in this chapter:

- ❑ **Power On Self Test (POST)**
- ❑ **Frequently Asked Questions**

Power on Self Test (POST)

After the power has been turned on, Video Server will perform a self-diagnostic to detect any possible hardware defects. The status LEDs will blink during the POST, and will keep blinking until the POST has finished, or a fatal error is detected. If either status LED indicator is dim to start off with, the LED may be broken.

When certain fatal errors occur, LED2 and LED3 blink in a particular way to indicate the type of failure, as described in the following table.

LED pattern after POST	Failed function	Troubleshooting
LED2 and LED3 blink at same time	U32(SAA7113)	Video decoder
LED2 ON and LED3 OFF	U1(TM1300)	PCI bridge of TM1300
LED2 OFF and LED3 ON	U6(RTL8139C)	Ethernet controller
LED2 ON and LED3 ON	U6(RTL8139C), U7, U8	Ethernet interface*
LED2 blink and LED3 ON	U22(M5823)	Real-time clock
LED2 ON and LED3 blink	U19(16C1550CJ), P2	COM interface

NOTE Ethernet interface failure includes not only on-board components, but also the Ethernet cable and the devices at the opposite end.

NOTE To reduce the chance of system failures caused by Administrator error, always read the related sections in this user's manual to prevent unexpected errors caused by "wild-guess configuration."

Frequently Asked Questions

Q: What if I forget my password?

A: Every access to Video Server needs authentication. If you are one of the managed users, you need to ask the administrator for the password. If you are the administrator, there is no way to recover the root password. The only way to regain access to Video Server is to utilize the default setting button on the rear panel to restore the factory settings and reinstall it (see p. 1-7 for details).

Q: Why can't I see video from the Video Server after it has been authenticated?

A: There are many possible scenarios:

1. If you have just installed the Video Server and are unable to see the video, check the video modulation on the Configuration page.
2. If the Video Server is installed correctly and you are accessing the Video Server for the first time using Internet Explorer, adjust the security level of Internet Explorer to allow installation of plug-ins.
3. If the problem still exists, the number of users accessing the Video Server at the same time may exceed the maximum that the system allows.

Q: What is the plug-in for?

A: The plug-in provided by Video Server is used to display motion pictures on versions of Internet Explorer that do not support server push technology. If your system does not allow installation of any plug-in software, the security level of the web browser may need to be lowered. It is recommended that you consult the network supervisor in your office before adjusting the security level.

Q: Why is the timestamp different from the system time of my PC or notebook?

A: The timestamp is based on the system time of Video Server. It is maintained by an internal real-time clock, and automatically synchronizes with the time server if Video Server is connected to the Internet and the function is enabled. Differences of several hours may result from the time zone setting.

Q: Why doesn't the image refresh regularly?

A: This may be due to the time taken for storing snapshots into memory when events occur.

Q. How does the Video Server detect the supported PTZ cameras automatically?

A. If a camera is not detected, the Video Server will monitor the CTS of the camera control cable continuously. As long as the CTS is detected, the Video Server will try to handshake with supported cameras until a supported camera is found. Camera detection will cease once a PTZ camera is recognized.

Q: How many users are allowed to access Video Server at the same time?

A: Basically, there is no limitation. However the video quality also depends on the network bandwidth. To achieve the best effect, the Video Server will allow 20 users to be connected. It is recommended to build another web server to host a large quantity of users by retrieving images from the Video Server periodically.

Q: What is Video Server's video rate?

A: The MPEG4 codec can process 30 frames per second internally. However the total performance is subject to many coefficients as follows:

1. Network throughput.
2. Bandwidth share.
3. Number of users.
4. The complicated objects in view results in larger image file.
5. The level of your PC or notebook which is responsible for displaying images.

In general, the transfer rate for a general local network environment can achieve over 200 kilobytes per second and approximately 10 to 20 pictures of a normal environment per second.

Q: How can I keep the Video Server as private as possible?

A: The Video Server is designed for surveillance purposes and has many flexible interfaces. The user authentication and special confirmation in installation can keep the Video Server from unauthorized access. You may also change the HTTP port to a non-public number. You can check the system log to examine any abnormal activities and trace the origins.

Q: I have a PTZ camera that is not on the support list. How can I control it?

A: Video Server provides a custom camera command interface to control cameras that are not supported. The details are described in this manual. Be sure that the COM port settings are applied to the camera specifications. The camera control cable included is shown in the package contents. Prepare your own cable if necessary. The general PTZ command is composed of one start command and one stop command. When editing both commands in the edit box of the configuration page, use comma(s) to separate commands. Each comma represents 200 milliseconds. If the user has some serial control device other than the PTZ camera, the special URL is provided to send the desired commands. For quick access, integrate the URL to another homepage on your own web server.

Q: How fast will Video Server check the status of digital inputs?

A: The Video Server will check input status in less than half a second. However, to avoid repeatedly checking conditions too often and to allow the devices connected to digital outputs to function properly, the Video Server will delay 3 seconds by default after each condition matches. Users may change it according to specific applications. During this period, any condition will be ignored.

Q: Why can I not access the Video Server when I set up some options in the application?

A: When the Video Server is triggered by events; snapshots will take more time to write to memory. If the events occur too often, the system will always be busy storing images. It is recommended to use sequential mode or an external recorder program to record motion pictures if the event is frequent. If you prefer to retrieve images via FTP, the value could be smaller since FTP responds quicker than the Web does. Once the system is too busy to configure, use the restore factory default and reset button to save the system.

Q: I tried connecting my black-and-white and color cameras with the Video Server but the image is not good.

A: Although the Video Server allows users to choose color or black-and-white images for each camera, hybrid camera types may increase video processing time and reduce system performance.

Q: The image is not clear enough. Is anything broken?

A: The lens can be focused by rotating the outer ring. Rotate it clockwise or counter-clockwise to focus near or far.

A

URL Commands of Video Server

Video Server can be easily integrated with existing websites or web control applications using convenient URLs. This section lists the commands in URL format corresponding to the basic functions of Video Server. Some RFC standards related to HTML may be a good reference for implementation of the customized homepage.

Page URL

The configuration page has a frame layout that includes an option list frame and an option page frame. Except for the configuration page, the Reference URLs shown below link just to the option page frame. Some pages, such as image quality settings and preset settings, open in a new browser window. These URLs can be accessed only by administrators.

Homepage name	Referenced URL
Client setting page	/client.html
configuration page	/setup/config.html
system option	/setup/system.html
security option	/setup/security.html
network option	/setup/network.html
video option	/setup/video.html
image quality option	/setup/image.html
camera control	/setup/camera.html
preset PTZ camera	/setup/preset.html
custom command setting	/setup/command.html
custom camera setting	/setup/custom.html
application option	/setup/app.html
homepage layout option	/setup/layout.html
system log	/setup/logfile.html
system parameters	/setup/parafile.html
set factory default	/setup/factory.html

System Resource URL

Some images are used on the homepage when the homepage layout is in image mode. Administrators may use the following links to show the images saved on Video Server on another page. To change the logo or the background images referenced by the URL, refer to the homepage layout section under configuration.

Resource name	Reference URL
system logo image	/pic/logo.gif
background image	/pic /back.gif
icon image for link indicator	/pic /btn_text.gif

General Format of Command URL

Every configuration can be set through URL with POST method by Administrator only.

<General format>
 URL [? [Name=value][&name=value],.....]
 <Method>
 POST
 <Authorized user>
 Root

System Configuration URL

URL: /setup/system.cgi

Name	Value	Description
host	<text string shorter than 15 characters>	system name
method	keep	keep date and time unchanged
	auto	use NTP server to synchronize
	manu	directly adjust date and time
date	<yy/mm/dd>	year, month and date separated by slash
time	<hh:mm:ss>	hour, minute and second separated by colon
ntp	<domain name or IP address>	NTP server
zone	-12 ~ 12	time zone, 8 means GMT +8:00

Security configuration URL

URL: /setup/security.cgi

Name	Value	Description
rootpass	<text string shorter than 15 characters>	change root password
username	<text string shorter than 15 characters>	add new user
userpass	<text string shorter than 15 characters>	new user's password
deluser	<text string shorter than 15 characters>	existing user name

Network configuration URL

URL: /setup/network.cgi

Name	Value	Description
reset	YES	enable installation at next boot
	NO	disable installation at next boot
ip	<IP address>	Video Server's IP address
subnet	<IP address>	subnet mask
router	<IP address>w	default gateway
domain	<text string shorter than 40 characters>	domain name of Video Server
dns1	<IP address>	primary DNS server
dns2	<IP address>	secondary DNS server
smtp1	<domain name or IP address>	primary SMTP server
mailto1	<text string shorter than 80 characters>	mail recipient address
smtp1Usr	<text string shorter than 39 characters>	Account name of SMTP1
smtp1pass	<text string shorter than 39 characters>	Password of account in SMTP1
smtp2	<domain name or IP address>	secondary SMTP server
Smt2Usr	<text string shorter than 39 characters>	Account name of SMTP2
Smt2pass	<text string shorter than 39 characters>	Password of account in SMTP2
mailto2	<text string shorter than 80 characters>	mail recipient address
return	<text string shorter than 80 characters>	return address
http	<number less than 65535>	HTTP port
controlport	<number less than 65535>	Control Channel port
videoport	<number less than 65535>	Video Channel port
audioport	<number less than 65535>	Audio Channel port
lowband	yes	enable the low bandwidth environment
	no	disable the low bandwidth environment
mute	yes	Enable audio streaming
	no	disable audio streaming
ftp1	<domain name or IP address>	primary FTP server
ftpuser1	<text string shorter than 15 characters>	user name for primary FTP server
ftppass1	<text string shorter than 15 characters>	password for primary FTP server
ftpfolder1	<text string shorter than 40 characters>	upload folder in primary FTP server
ftp2	<domain name or IP address>	secondary FTP server
ftpuser2	<text string shorter than 15 characters>	user name for secondary FTP server
ftppass2	<text string shorter than 15 characters>	password for secondary FTP server
ftpfolder2	<text string shorter than 40 characters>	upload folder in secondary FTP server

Video configuration URL

URL: /setup/video.cgi

Name	Value	Description
text	<text string shorter than 15 characters>	enclose caption
color	B/W	set encoder to monochrome
	<other than B/W>	set encoder to color
size	1	half
	2	half x 2
	3	normal
	4	Normal x 2
	5	double
quality	fixb	fix bit rate
	<other than fixb>	fix quantization
quan	1	lowest quality of video
	2	lower quality of video
	3	normal quality of video
	4	higher quality of video
	5	highest quality of video
bitrate	64000	set bit rate to 64K bps
	128000	set bit rate to 128K bps
	256000	set bit rate to 256K bps
	384000	set bit rate to 384K bps
	512000	set bit rate to 512K bps
	768000	set bit rate to 768K bps
	1000000	set bit rate to 1000K bps
	1200000	set bit rate to 1200K bps
mode	Auto	let Video Server detect video modulation
	NTSC	set directly to NTSC type
	<other than above>	set directly to PAL type
frame	1	set maximum frame rate to 1 fps
	2	set maximum frame rate to 2 fps
	3	set maximum frame rate to 3 fps
	5	set maximum frame rate to 5 fps
	10	set maximum frame rate to 10 fps
	15	set maximum frame rate to 15 fps
	20	set maximum frame rate to 20 fps
	25	set maximum frame rate to 25 fps
	30	set maximum frame rate to 30 fps(NTSC only)
	enablemd	yes
<other than yes>		disable motion detection
flip	yes	flip image
	<other than yes>	normal image
mirror	yes	mirror image
	<other than yes>	normal image

Image quality configuration URL

URL: /setup/image.cgi

Name	Value	Description
brightness	<-5 ~ 5>	adjust brightness of image
contrast	<-5 ~ 5>	adjust contrast of image
hue	<-5 ~ 5>	adjust hue of image
saturation	<-5 ~ 5>	adjust saturation of image
preview	<not required>	not save the parameters
restore	<not required>	recall the original settings
save	<not required>	save the parameters

Camera configuration URL

URL: /setup/camera.cgi

Name	Value	Description
interface	RS232	switch COM to RS232
	<other than RS232>	switch COM to RS485
driver	0	non-PTZ camera device
	1	Custom PTZ camera
	2	Sony EVI-D30/31
	3	Canon VCC1
	4	Canon VCC3
	5	Canon VCC4
	6	DynaDome/SmartDOME
	7	Pelco D protocol

Camera preset configuration URL

URL: /setup/preset.cgi

Name	Value	Description
addpos	<text string shorter than 40 characters>	add preset position
delpos	<existing position name>	delete preset position

Camera custom command configuration URL

URL: /setup/command.cgi

Name	Value	Description
str1	<text string shorter than 8 characters>	button name of custom command 1 of COM
str2	<text string shorter than 8 characters>	button name of custom command 2 of COM
str3	<text string shorter than 8 characters>	button name of custom command 3 of COM
str4	<text string shorter than 8 characters>	button name of custom command 4 of COM
str5	<text string shorter than 8 characters>	button name of custom command 5 of COM
com1	<text string shorter than 80 characters>	custom command 1 of COM
com2	<text string shorter than 80 characters>	custom command 2 of COM

com3	<text string shorter than 80 characters>	custom command 3 of COM
com4	<text string shorter than 80 characters>	custom command 4 of COM
com5	<text string shorter than 80 characters>	custom command 5 of COM

Custom camera configuration URL

URL: /setup/custom.cgi

Name	Value	Description
baud	<integer>	set baud rate of COM
data	<integer>	set data bits of COM
stop	1	set 1 stop bit of COM
	2 <other than 1>	set 2 stop bits of COM
parity	None	set parity check of COM to none
	Odd	set parity check of COM to odd
	Even	set parity check of COM to even
up	<text string shorter than 80 characters>	tilt up command string of COM
down	<text string shorter than 80 characters>	tilt down command string of COM
left	<text string shorter than 80 characters>	pan left command string of COM
right	<text string shorter than 80 characters>	pan right command string of COM
home	<text string shorter than 80 characters>	home command string of COM
tele	<text string shorter than 80 characters>	zoom in command string of COM
wide	<text string shorter than 80 characters>	zoom out command string of COM

Application configuration URL

URL: /setup/app.cgi

Name	Value	Description
emode	<not required>	event mode application
smode	<not required>	sequential mode application
smethod	mail	upload snapshots by email
	ftp	upload snapshots by FTP
suffix	<not required>	FTP file with date and time suffix
delay	<integer>	seconds delay to detect next event
inter	<integer>	seconds delay to capture post-event
dihigh	< not required >	set DI high as trigger condition
dilow	< not required >	set DI low as trigger condition
dirise	< not required >	set DI rising as trigger condition
difall	< not required >	set DI falling as trigger condition
motion1	< not required >	set motion window1 as trigger condition
motion2	< not required >	set motion window2 as trigger condition
motion3	< not required >	set motion window3 as trigger condition
ioalarm	< not required >	trigger DO when DI condition matched
mdalarm	< not required >	trigger DO when motion detected
ioupload	< not required >	upload snapshot when DI condition matched
mdupload	< not required >	upload snapshot when motion detected
sinter	<integer>	seconds interval for sequential mode
sbegin	<hh:mm:ss>	time to start sequential mode

send	<hh:mm:ss>	time to stop sequential mode
------	------------	------------------------------

Homepage layout configuration URL

URL: /setup/layout.cgi

Name	Value	Description
cuslogo	blank	hide logo
	def	use default logo
	url	use image from URL
logourl	<text string shorter than 80 characters>	URL of image for logo
linkurl	<text string shorter than 80 characters>	URL to link when clicking on logo
cusback	blank	hide background image
	def	use default background
	url	use image from URL
backurl	<text string shorter than 80 characters>	URL of image for background
fcolor	<0 ~ 15>	color index for font
bcolor	<0 ~ 15>	color index for background

DDNS & UPNP configuration URL

URL: /setup/ddns.cgi

Name	Value	Description
enddns	<not required>	Enable DDNS
provider	1 or 2	dyndns
	3	TZO
	4	DHS
host	<text string shorter than 38 characters>	Host name
usermail	<text string shorter than 38 characters>	Account name of DDNS
passkey	<text string shorter than 38 characters>	password of DDNS
enupnp	<not required>	Enable UPnP

B

Settings of Supported PTZ Cameras

Since the COM port settings can be adjusted to other than the default settings, check the correct default settings for the attached camera.

Camera model	Baud rate	Data bits	Stop bit	Parity bit
Sony VISCA	9600	8	1	None
Canon VC-C1	9600	8	2	None
Canon VC-C3	9600	8	2	None
Canon VC-C4	9600	8	1	None
Pelco D protocol	2400	8	1	None
DynaDome/SmartDome	9600	8	1	None

C

Camera Control Cable

The included cable can be used to control motorized cameras of desktop types from Sony and Canon. The pin assignment is illustrated in the following chart. To control cameras of another brand, check the user's manual of the motorized camera to see if the pin assignment of the control cable is appropriate.

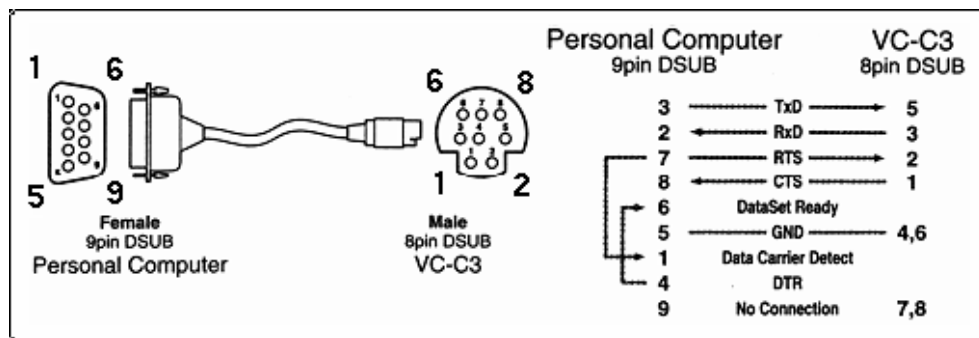

D

Time Zone Table

The hour offsets for different time zones are shown below. You will need this information when setting the time zone in automatic date/time synchronization. GMT stands for Greenwich Mean Time, which is the global time that all time zones are measured from.

(GMT-12:00)	International Date Line West
(GMT-11:00)	Midway Island, Samoa
(GMT-10:00)	Hawaii
(GMT-09:00)	Alaska
(GMT-08:00)	Pacific Time (US & Canada), Tijuana
(GMT-07:00)	Arizona
(GMT-07:00)	Chihuahua, La Paz, Mazatlan
(GMT-07:00)	Mountain Time (US & Canada)
(GMT-06:00)	Central America
(GMT-06:00)	Central Time (US & Canada)
(GMT-06:00)	Guadalajara, Mexico City, Monterrey
(GMT-06:00)	Saskatchewan
(GMT-05:00)	Bogota, Lima, Quito
(GMT-05:00)	Eastern Time (US & Canada)
(GMT-05:00)	Indiana (East)
(GMT-04:00)	Atlantic Time (Canada)
(GMT-04:00)	Caracas, La Paz
(GMT-04:00)	Santiago
(GMT-03:30)	Newfoundland
(GMT-03:00)	Brasilia
(GMT-03:00)	Buenos Aires, Georgetown
(GMT-03:00)	Greenland
(GMT-02:00)	Mid-Atlantic
(GMT-01:00)	Azores
(GMT-01:00)	Cape Verde Is.
(GMT)	Casablanca, Monrovia
(GMT)	Greenwich Mean Time: Dublin, Edinburgh, Lisbon, London
(GMT+01:00)	Amsterdam, Berlin, Bern, Stockholm, Vienna
(GMT+01:00)	Belgrade, Bratislava, Budapest, Ljubljana, Prague
(GMT+01:00)	Brussels, Copenhagen, Madrid, Paris
(GMT+01:00)	Sarajevo, Skopje, Warsaw, Zagreb
(GMT+01:00)	West Central Africa
(GMT+02:00)	Athens, Istanbul, Minsk
(GMT+02:00)	Bucharest
(GMT+02:00)	Cairo

(GMT+02:00) Harare, Pretoria
(GMT+02:00) Helsinki, Kyiv, Riga, Sofia, Tallinn, Vilnius
(GMT+02:00) Jerusalem
(GMT+03:00) Baghdad
(GMT+03:00) Kuwait, Riyadh
(GMT+03:00) Moscow, St. Petersburg, Volgograd
(GMT+03:00) Nairobi
(GMT+03:30) Tehran
(GMT+04:00) Abu Dhabi, Muscat
(GMT+04:00) Baku, Tbilisi, Yerevan
(GMT+04:30) Kabul
(GMT+05:00) Ekaterinburg
(GMT+05:00) Islamabad, Karachi, Tashkent
(GMT+05:30) Chennai, Kolkata, Mumbai, New Delhi
(GMT+05:45) Kathmandu
(GMT+06:00) Almaty, Novosibirsk
(GMT+06:00) Astana, Dhaka
(GMT+06:00) Sri Jayawardenepura
(GMT+06:30) Rangoon
(GMT+07:00) Bangkok, Hanoi, Jakarta
(GMT+07:00) Krasnoyarsk
(GMT+08:00) Beijing, Chongqing, Hongkong, Urumqi
(GMT+08:00) Taipei
(GMT+08:00) Irkutsk, Ulaan Bataar
(GMT+08:00) Kuala Lumpur, Singapore
(GMT+08:00) Perth
(GMT+09:00) Osaka, Sapporo, Tokyo
(GMT+09:00) Seoul
(GMT+09:00) Yakutsk
(GMT+09:30) Adelaide
(GMT+09:30) Darwin
(GMT+10:00) Brisbane
(GMT+10:00) Canberra, Melbourne, Sydney
(GMT+10:00) Guam, Port Moresby
(GMT+10:00) Hobart
(GMT+10:00) Vladivostok
(GMT+11:00) Magadan, Solomon Is., New Caledonia
(GMT+12:00) Auckland, Wellington
(GMT+12:00) Fiji, Kamchatka, Marshall Is..
(GMT+13:00) Nuku'alofa



Technical Specifications

Technology

Video Inputs (BNC)	1
Audio Inputs (RCA)	1 mono (24 Kbps wideband audio coding)
NTSC/PAL	Auto-sensing

Network

Protocols	TCP, UDP, HTTP, SMTP, FTP, Telnet, NTP, DNS, DDNS, DHCP, UPnP
Ethernet	Auto-sensing 10/100 Mbps

Video

Video Compression	MPEG4
Video Resolution	<u>NTSC:</u> Up to 30 frames at 176 × 120 Up to 30 frames at 352 × 240 Up to 10 frames at 704 × 480 <u>PAL:</u> Up to 25 frames at 176 × 144 Up to 25 frames at 352 × 288 Up to 8 frames at 704 × 576
Video Viewing	<ul style="list-style-type: none">• Adjustable image size and quality• B/W or Color control• Timestamp and text overlay

Serial Port

COM	DB9 Male RS-232, Max. 115.2 Kbps
RS-485	Terminal Block for Data +, Data - Max. 115.2 Kbps

GPIO

Digital Input	1 (max. 12 VDC @ 50 mA)
Relay Output	1 (max. 24 VDC @ 1A, 125 VAC @ 0.5A)
LED Indicators	NETWORK: network links CONNECT: system active SERIAL: serial status

Mechanical	
Dimensions (W x D x H)	72.25 x 106 x 50 mm
Weight	420 g
Installation	DIN-Rail Mounting, Wall Mounting
Power Requirements	
Input	6-15 VDC min.15W
Consumption	near 4.2W
Environmental	
Operating Temperature	0 to 60°C (32 to 140°F)
Storage Temperature	-30 to 70°C (-40 to 158°F)
Humidity	5% to 95% (non-condensing)
Regulatory Approvals	CE, FCC
Warranty	5 years
Alarm Features	<ul style="list-style-type: none"> • Video Motion detection with percentage and sensitivity • Daily repeat timing schedule • 3 color JPEG images for pre/post alarm image storage • Automatic transfer of stored images via email or FTP with event-triggered actions
PAN/TILT/ZOOM	<ul style="list-style-type: none"> • PTZ camera control through RS-232/485 • Automatic PTZ camera model detection • Supported devices and protocol: Sony VISCA, Canon VC-C1/VC-C3, Dynacolor SmartDOME, Pelco D-protocol, Liling PIH-7x00, CCTV, Coho, Custom Camera
Remote Firmware Upgrade	System firmware upgradeable via bundled Upgrade Wizard or FTP
Security	User level password protection
Viewing System requirement	<ul style="list-style-type: none"> • Internet Explorer 4.x or above • Netscape Navigator 4.x or above
Software Bundled Free	Moxa SoftDVR Lite: 1- to 4-ch IP Surveillance Software for viewing & recording