

Moxa VPort D361 Industrial Video Decoder User's Manual

First Edition, June 2011

www.moxa.com/product

MOXA®

© 2011 Moxa Inc. All rights reserved.

Moxa VPort D361 Industrial Video Decoder User's Manual

The software described in this manual is furnished under a license agreement and may be used only in accordance with the terms of that agreement.

Copyright Notice

© 2011 Moxa Inc. All rights reserved.

Trademarks

The MOXA logo is a registered trademark of Moxa Inc.
All other trademarks or registered marks in this manual belong to their respective manufacturers.

Disclaimer

Information in this document is subject to change without notice and does not represent a commitment on the part of Moxa.

Moxa provides this document as is, without warranty of any kind, either expressed or implied, including, but not limited to, its particular purpose. Moxa reserves the right to make improvements and/or changes to this manual, or to the products and/or the programs described in this manual, at any time.

Information provided in this manual is intended to be accurate and reliable. However, Moxa assumes no responsibility for its use, or for any infringements on the rights of third parties that may result from its use.

This product might include unintentional technical or typographical errors. Changes are periodically made to the information herein to correct such errors, and these changes are incorporated into new editions of the publication.

Technical Support Contact Information

www.moxa.com/support

Moxa Americas

Toll-free: 1-888-669-2872
Tel: +1-714-528-6777
Fax: +1-714-528-6778

Moxa Europe

Tel: +49-89-3 70 03 99-0
Fax: +49-89-3 70 03 99-99

Moxa China (Shanghai office)

Toll-free: 800-820-5036
Tel: +86-21-5258-9955
Fax: +86-21-5258-5505

Moxa Asia-Pacific

Tel: +886-2-8919-1230
Fax: +886-2-8919-1231

Table of Contents

1. Introduction	1-1
Overview	1-2
Package Checklist	1-3
Product Features	1-3
Typical Application	1-4
Panel Layout of the VPort D361	1-5
Product Description	1-5
BNC Video Output	1-5
Mini Stereo Jacks for Audio Input/Output	1-6
LED Indicators	1-6
10/100 Mbps Ethernet Port	1-6
RS-232/RS-422/RS-485 PTZ COM Port	1-6
12/24 VDC and 24 VAC Power Inputs	1-7
General I/O Terminal Blocks	1-7
RS-232 Console Port	1-7
Reset Button	1-8
2. Getting Started	2-1
The Meaning of "User" and "Administrator"	2-2
First-Time Installation and Configuration	2-2
RS-232 Console Configuration (115200, None, 8, 1, VT100)	2-6
Mounting the VPort D361	2-10
Mounting Dimensions (unit= mm)	2-10
DIN-Rail Mounting	2-10
Wall Mounting (Optional)	2-11
Wiring Requirements	2-11
Grounding the VPort D361	2-12
Wiring the Relay Output	2-12
Wiring the Power Input	2-12
Wiring the Digital Inputs	2-13
Communication Connections	2-13
10/100BaseT(X) Ethernet Port Connection	2-13
Auto MDI/MDI-X	2-14
3. Accessing VPort D361's Web-based Manager	3-1
Functions Featured on the VPort's Web Homepage	3-2
VPort's Information	3-2
Current Video Source Information	3-2
Video Source Selection	3-2
Video Source List	3-2
System Configuration	3-3
Relay Control	3-3
4. System Configuration	4-1
Using the Web-based Manager for System Configuration	4-2
System	4-3
General Settings	4-3
Account Privileges	4-4
System Diagnosis	4-5
System Log History	4-5
System Parameters	4-5
Firmware Upgrade	4-6
Reset to Factory Default	4-7
Reboot	4-7
Network	4-7
General Network Settings	4-7
SMTP Server and Email Account Settings	4-9
Universal PnP	4-9
Accessible IP List	4-10
SNMP	4-11
Configuring SNMP Settings	4-11
SNMP Read/Write Settings	4-12
Private MIB Information	4-13
Modbus/TCP	4-13
Video Source	4-14
Video Source List	4-14
Video Source Log	4-16
Video	4-17
OSD Settings	4-17
Video Output	4-18

Audio	4-18
Audio Settings	4-18
Transparent PTZ	4-19
Alarm	4-20
Relay Settings	4-20
System Alarm	4-20
DI Event Alarm	4-21
A. How to Set Up the Alarm Trigger Function	A-1
B. Modus Address Table	B-1
C. Time Zone Table	C-1
D. Technical Specifications	D-1

1

Introduction

The VPort D361 is a high-performance networked video decoder used to convert digital video streams to analog video signals.

The following topics are covered in this chapter:

- **Overview**
- **Package Checklist**
- **Product Features**
- **Typical Application**
- **Panel Layout of the VPort D361**
- **Product Description**

Overview

The VPort D361 is a 1-channel video decoder for decoding H.264/MJPEG video streams from VPort series video encoders and VPort IP cameras back to analog video signals. The analog video signal can be sent to legacy CCTV devices, such as monitors, multiplexers, and matrix switches, which can be used as originally intended as part of CCTV systems. In addition, bi-directional audio enables ready-to-use voice-over-IP communications between the video encoder and decoder.

Monitoring your cameras as part of a large CCTV system is easy with the VPort D361, which can be set up to switch between different video sources manually or automatically within a given time interval. Up to 64 video sources can be included in the list. In addition, the two DIs located on the top panel of the VPort D361 can be used to create two control buttons for up and down video source selection.

Decodes the VPort's MJPEG/H.264 video streams automatically

The VPort D361 can decode digital video streams that are generated from some VPort series video encoders and IP cameras back to analog video signals for use with legacy CCTV equipment, such as CCTV monitors, making the VPort D361 an important tool for protecting your investment in CCTV equipment.

2-way audio support for a complete surveillance solution

The VPort D361 supports both audio input and audio output for voice over IP communication between field sites and a central site. The 2-way audio function not only saves time, but also saves the cost of needing to add additional communication devices, such as a telephone.

Up to 64 video source channels supported for manual or auto-scan selection

The VPort D361 supports up to 64 video source channels in one unit, providing users with the convenience of conducting wide-scale video surveillance with just one monitor. Users can manually select the video sources from the web browser or 2 DIs (DI1 is up and DI2 is down). An auto-scan mode is also provided for changing the video source automatically in a given time interval.

Automatically switch to the video source upon alarm activation

The VPort D361 can be configured to switch the active video source automatically to the source of the alarm. This function allows users to check the cause of the alarm immediately without missing any video. Once the alarm passes, you can manually switch the video source and resume normal operation.

Transparent PTZ control through the PTZ COM port

A "Transparent PTZ Control" is available to control cameras with a legacy PTZ control panel or keyboard, which means that many brands and models of PTZ camera can be controlled without the need to install PTZ drivers. Just connect your legacy PTZ control panel or keyboard to the PTZ port of the VPort D361 to control the PTZ camera connected to the VPort video decoder directly.

Convenient OSD (on-screen display) setup for customized information

Since analog video systems are not very convenient for bundling or checking more detailed information, an OSD (on-screen display) is an important tool that can be used to keep track of which video source is active. The VPort D361 provides convenient OSD functions, including a video source index, video source IP, and customized information defined by the users. In addition, users can also set up the coordinates of the OSD information for good display.

Easy web access with standard browsers

There is no need to install new software to access the video decoder, since the embedded web server allows users to use any popular web browser to access the video decoder from anywhere over the Internet. As long as you are connected to the network, you will be able to set up the video encoder easily.

Flexible I/O control for switching the video source, or connecting the external I/O devices

Two opto-isolated sensor inputs (DI) and 2 relay outputs (Relay or DO) are provided to control external devices, giving system integrators the option of turning an analog system into an advanced security system. In addition,

the 2 DIs also can be used for selecting the video source. DI1 can function as a UP selection (for example, from video source 1 to 2), and DI2 can function as a DOWN selection (for example, from video source 2 to 1).

Support for SNMP V1, V2c, and V3 for easy network management

More and more IP devices are networked for use on one TCP/IP network. To make management and maintenance easier, SNMP (Simple Network Management Protocol) can be used to monitor all of these IP devices.

CGI command support for 3rd -party developers

The VPort D361 also supports CGI commands for 3rd party developers who would like to integrate the control of a video decoder into their system. The CGI commands can be downloaded from Moxa's website free of charge.

Package Checklist

Moxa's VPort D361 is shipped with the items listed below. If any of these items is missing or damaged, please contact your customer service representative for assistance.

- 1 × VPort D361
- 1 × 4-pin terminal block for 2 DIs
- 1 × 8-pin terminal block for a power input and 2 relay outputs
- 1 × 5-pin terminal block for the RS-232/422/485 PTZ control port
- Quick Installation Guide
- Document & Software CD (includes User's Manual, Quick Installation Guide, and VPort Utility)
- Warranty statement

NOTE: Notify your sales representative if any of the above items are missing or damaged.

Product Features

High performance video/audio networking solution

- channel video output for analog NTSC/ PAL video signals
- 1 audio input and 1 audio output for 2-way voice communication
- 1 auto-sensing 10/100BaseT(X) Ethernet port
- TCP, UDP, HTTP, and multicast network transmission modes
- 1 RS-232/422/485 PTZ port with serial-to-Ethernet Real COM mode for remote PTZ control with existing legacy PTZ control devices (PTZ control driver NOT required)
- Capability to decode different video stream resolutions from video encoder with a maximum of 540 TVL lines
- Maximum of 64 video sources can be set up as the decode video source
- Supports for manually selecting the video sources, or automatically scanning for video sources
- Supports 2 digital inputs to switch the video sources
- Supports SNMP (V1/V2C/V3) for network system integration and management
- Built-in web server and RS-232 console for remote access and configuration
- Supports OSD (On-Screen Display)
- Supports UPnP and IP filtering

Industrial Rugged Design

- 1 12/24 VDC and 24 VAC power inputs with LED indicator
- 35 mm DIN-rail mounting or panel mounting installation (with optional accessories)
- Optional model with -40 to 75° C operating temperature range

- IP30 protection form factor
- CE, FCC, and UL508 industrial certifications

Intelligent Alarm Trigger

- Equipped with 2 DIs and 2 relays (DOs) for external sensors and alarms
- Supports automatically switching to a specific video source in response to an event triggered by the VPort video encoder
- Supports SMTP for system or alarm message transmission

NOTE Please link to Moxa's website to download the VPort D361's CGI commands if you need the commands for your system integration.

Typical Application

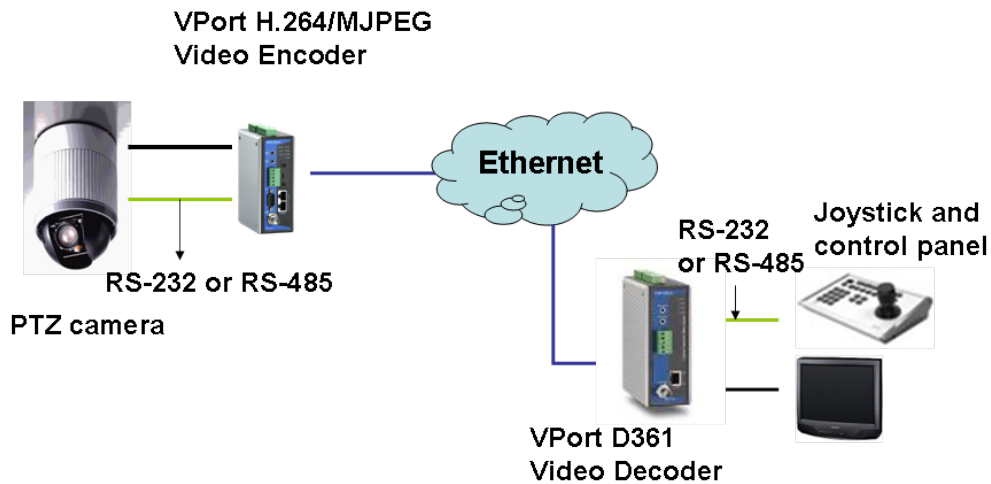

Panel Layout of the VPort D361

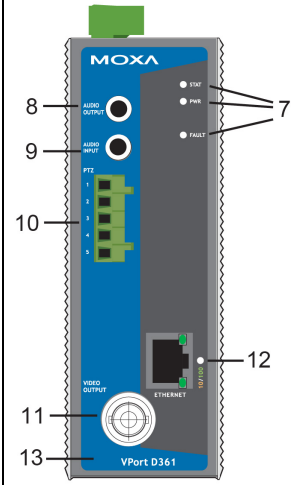
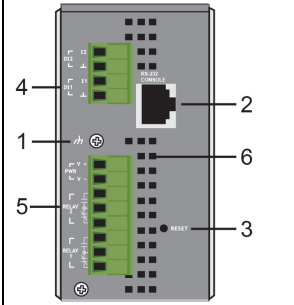
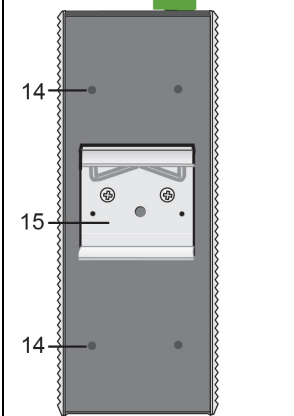
<p style="text-align: center;">VPort D361 Front Panel View</p>  <p style="text-align: center;">Top Panel View</p>  <p style="text-align: center;">Rear Panel View</p> 	<ol style="list-style-type: none"> 1. Grounding screw 2. RS-232 console port 3. Hardware reset button 4. 4-pin terminal block for DI 1 and DI 2 5. 8-pin terminal block for Relay 1, Relay2, power input (PWR) 6. Heat dissipation orifices 7. LEDs for STAT, PWR1, PWR2, FAULT 8. AUDIO OUTPUT port for external speaker 9. AUDIO INPUT port for mic-in and line-in connection 10. 5-pin terminal block for RS-232/422/485 connection 11. BNC port for analog video output 12. RJ45 10/100BaseTX Ethernet port with 10 Mbps, 100 Mbps LEDs 13. Model name 14. Screw hole for wall mounting kit 15. DIN-Rail mounting kit
--	--

Product Description

BNC Video Output

The BNC video output is a 75 Ohm, 1 Vpp video port for connecting an external CCTV device, such as monitor.

Mini Stereo Jacks for Audio Input/Output

The VPort 351 has 2 mini stereo jacks on the front panel for audio input and output. One jack is for a MIC-in/Line-in audio input connection, which can be directly connected with a microphone or an audio source from an amplifier. The other jack is a Line-out audio output connection, which can be used to connect earphones or an amplifier.

LED Indicators

The front panel of the VPort D361 contains several LED indicators. The function of each LED is described in the table below.

LED	Color	State	Description
STAT	GREEN/RED	RED ON	Hardware initialization
		RED FLASH	Software initialization
		GREEN ON	System boot-up
		GREEN FLASH	Firmware upgrade underway
PWR	AMBER	On	Power is being supplied to power input
		Off	Power is not being supplied to power input
FAULT	RED	On	Three conditions could cause the LED to light up: One of the 2 power inputs is disconnected. Network disconnected Settings can be modified on the System Configuration → Alarm → System Alarm page.
		Off	Both power inputs are connected and working, or there is no video loss, or the network disconnected alarm is silent (if it has been activated).
10/100	AMBER	On	10 Mbps link is active
		Blinking	Data is being transmitted at 10 Mbps
		Off	10 Mbps link is inactive
	GREEN	On	100 Mbps link is active
		Blinking	Data is being transmitted at 10 Mbps
		Off	100 Mbps link is inactive

NOTE After powering on the VPort D361, wait a few minutes for the POST (Power On Self Test) to run. When the POST is running, the STAT LED will first be lit in RED during the hardware initialization. It will then blink in RED during software initialization. After the POST finishes, the LED will be lit in GREEN to show that it is working properly.

10/100 Mbps Ethernet Port

The VPort D361 provides one RJ45 Ethernet port for a 10/100 Mbps Ethernet connection. Two LED indicators are located on the corner of the RJ45 Ethernet port to indicate if the link speed is 10 Mbps or 100 Mbps.

RS-232/RS-422/RS-485 PTZ COM Port

The VPort D361 provides 1 RS-232/422/485 COM port for PTZ control. The port uses a 5-pin terminal block connector with the following pin assignments.

PIN	RS-422/485		RS-232	
1	GND	Ground	GND	Ground

2	R-	Rx-	---	N/A
3	R+	Rx+	RxD	RxD
4	T-\D-	Tx-/ Data-	---	N/A
5	T+\D+	Tx+/ Data+	TxD	TxD

NOTE The VPort series video encoders support "Transparent PTZ Control," which is listed in the camera driver list. This function is used to transmit the PTZ control signal through a TCP/IP network to the VPort D361 video decoder or PC (additional Real COM driver required), and the PTZ control panel or keyboard can directly control the PTZ camera or device. In this way, there is no need for PTZ camera driver, and there are no protocol limitations for using a PTZ camera with a VPort encoder.

12/24 VDC and 24 VAC Power Inputs



The VPort D361's power input supports both 12/24 VDC and 24 VAC power for greater versatility.

NOTE The supported power input specifications for the VPort D361 series are 12 to 32 VDC for a 12/24 VDC power input, or 18 to 30 VAC for a 24 VAC power input. This differs from the Moxa EDS switch's 12 to 45 VDC power input.

General I/O Terminal Blocks

One 6-pin terminal block and one 8-pin terminal block are located on the VPort D361's top panel. The terminal blocks provide 2 digital inputs (DIs), 2 relay outputs (DOs), and 2 power inputs. These digital inputs and relay outputs are for linking to peripheral devices, such as sensors and alarms, and can be employed when using the VPort D361 to create an intelligent alarm system for system operation (power failure, disconnected network).

In addition, the VPort D361's DI 1 and DI 2 can also be used for controlling the selection of the video source. The Administrator can set up this function by checking the **Enable DI Change** checkbox under **System Configuration** → **Video Source** → **Video Source List**. DI 1 can then do backward video source selection (e.g., from video source 2 to video source 1), and DI 2 can do forward video source selection (e.g., from video source 1 to video source 2).

Relay Output		Normal Open	Max. 1A, 24 VDC Initial status is Normal Open
		Common	
		Normal Close	
Digital Input		DI-	"High": +13V to +30V
		I1, I2 DI+	"Low": -30V to +3V

NOTE Please refer to the VPort D361 Quick Installation Guide to see how to wire the digital inputs and relay outputs.

RS-232 Console Port

The VPort D361 has one RS-232 (10-pin RJ45) console port located on the top panel. Use either an RJ45-to-DB9 cable or RJ45-to-DB25 cable to connect the VPort D361's console port to your PC's COM port. You may then use a console terminal program, such as Moxa PComm Terminal Emulator, to access the VPort 351's console configuration utility.

Reset Button

A recessed RESET button is provided for restoring the system to the factory default settings. When the system fails to install properly, or operates abnormally, push the RESET button located on the top panel of the VPort D361 to restore the factory defaults. To do this, use a pointed object such as a straightened paper clip or toothpick, to depress the reset button continuously. Release the reset button when the STAT LED stops flashing in red. At this point, the POST process will run, and the VPort will reboot. The STAT LED will light in green when the VPort has finished rebooting.

This chapter includes information about how to install a VPort D361 Video Decoder.

The following topics are covered in this chapter:

- ❑ **The Meaning of “User” and “Administrator”**
- ❑ **First-Time Installation and Configuration**
- ❑ **RS-232 Console Configuration (115200, None, 8, 1, VT100)**
- ❑ **Mounting the VPort D361**
 - Mounting Dimensions (unit= mm)
 - DIN-Rail Mounting
 - Wall Mounting (Optional)
- ❑ **Wiring Requirements**
 - Grounding the Moxa VPort D361
 - Wiring the Relay Output
 - Wiring the Redundant Power Input
 - Wiring the Digital Inputs
- ❑ **Communication Connections**
 - 10/100BaseT(X) Ethernet Port Connection
 - Auto MDI/MDI-X

The Meaning of “User” and “Administrator”

In what follows, “user” refers to those who can access the Video Server, and “Administrator” refers to the person who knows the root password that allows changes to the Video Encoder’s configuration. The Administrator also has general access. The Administrator should read this part of the manual carefully, especially during installation.

First-Time Installation and Configuration

Before installing the VPort D361, check to make sure that all items in the Package Checklist are present. In addition, you will need access to a notebook computer or PC equipped with an Ethernet port.

Step 1: Select the Power Source

The VPort D361 can be powered by a 12 to 32 VDC power input, or an 18 to 30 VAC power input. Users can check the LED status located on the front panel to see if the power input is connected appropriately.

NOTE The VPort D361 supports 12 to 32 VDC for a 12/24 VDC power input, or 18 to 30 VAC for a 24 VAC power input. This differs from the 12 to 45 VDC power input supported by Moxa’s EDS series of Ethernet switches.

Step 2: Connect the VPort D361 to a Network

The VPort D361 has an auto-sensing 10/100 Mbps RJ45 Ethernet port for network connectivity. The RJ45 port has LEDs for indicating 10 Mbps or 100 Mbps data transmission.

Step 3: Connect the VPort D361 to an audio source (if required)

The VPort D361 supports 1 **AUDIO INPUT** and 1 **AUDIO OUTPUT**. A microphone or an amplifier can be plugged directly into the **AUDIO INPUT** port; a speaker can be plugged into the **AUDIO OUTPUT** port.

Step 4: Connect the VPort D361 to a video output source

The VPort D361 supports 1 **VIDEO OUTPUT** for transmitting analog videos. Connect the video output source, such as CCTV monitor or switch, to the BNC connector to use the analog video signal.

Step 5: Connect the VPort D361 to a control panel or keyboard to control the motorized PTZ camera or device (if required)

If a motorized PTZ camera or device is used at the VPort encoder site, users can connect the PTZ control panel or keyboard to the VPort D361’s PTZ port to control the motorized PTZ camera or device directly once the connection between the VPort D361 and the VPort encoder is ready. The PTZ port uses a 5-pin terminal block for the RS-232/422/485 serial connection. The pin assignments are shown in the following table.

PIN	RS-422/485		RS-232	
1	GND	Ground	GND	Ground
2	R-	Rx-	---	N/A
3	R+	Rx+	RxD	RxD
4	T-\D-	Tx-/Data-	---	N/A
5	T+\D+	Tx+/Data+	TxD	TxD

NOTE The VPort D361 supports Transparent PTZ control, which means that the VPort D361 can connect directly to the PTZ control panel or keyboard to control the remote PTZ camera connected to the VPort series video encoders. Since the PTZ control protocol is not standardized, the PTZ control panel and keyboard must support the control of PTZ cameras.

NOTE Currently, VPort series video encoders support PTZ control protocol drivers for:

1. Pelco D
2. Pelco P
3. DynaColor DynaDome
4. Cohu

In addition, the camera driver list has an item named "Transparent PTZ Control." This is used to transmit the PTZ control signal over the TCP/IP network to the VPort D361 video decoder, so that the PTZ control panel or keyboard can directly control the PTZ camera or device. Using this method eliminates the need for a PTZ camera driver. In addition, you will be able to use any PTZ camera with your VPort series video encoders.

Step 6: Configure the VPort D361's IP address

After powering on the VPort D361, wait a few seconds for the POST (Power On Self Test) to run. The POST process is complete once the STAT LED turns green. The IP address will be assigned when the 10 or 100 Mbps NETWORK LED blinks. The value of the IP address that is assigned is based on the network environment.

Network Environment with DHCP Server

When a DHCP server is present, the IP address of the VPort D361 is assigned by the DHCP server. Use the DHCP server's IP address table, or use the Moxa VPort and EtherDevice Configurator utility to determine the IP address that was assigned by the DHCP server.

NOTE After powering on the VPort D361, wait a few seconds for the POST (Power On Self Test) to run. The IP address will be assigned when the 10 or 100 Mbps NETWORK LED blinks.

Using the Moxa VPort and EtherDevice Configurator Utility (edscfgui.exe)

1. Run the edscfgui.exe program to search for VPorts and EDS switches. After the Utility window opens, select or click Broadcast Search under the List Server menu, or click on the Broadcast Search icon  to initiate a search.

NOTE You may download the VPort and EtherDevice Configurator software from Moxa's website at www.moxa.com.

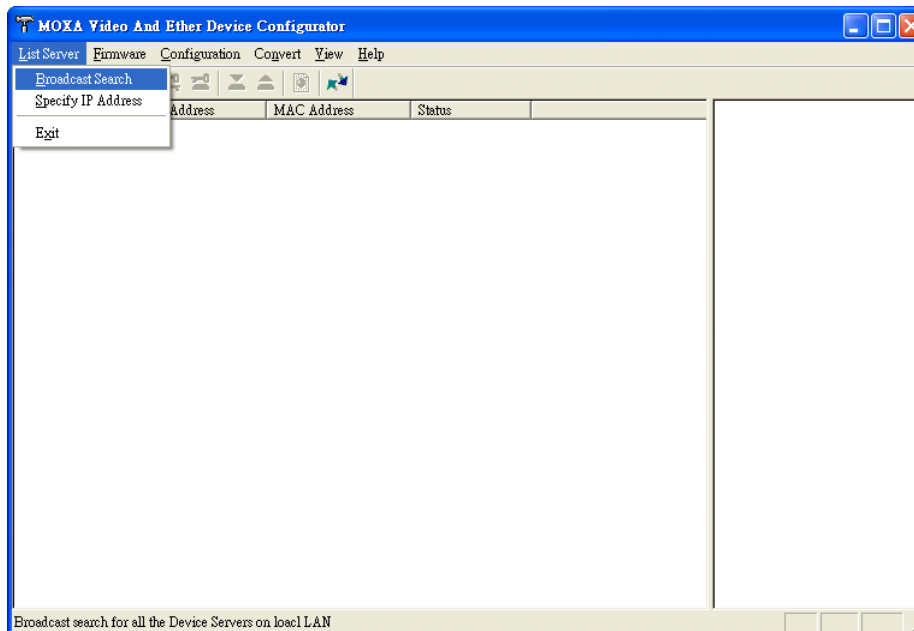

- The **Broadcast Search** window will display a list of all switches and VPorts products located on the network. The progress of the search will also be indicated.

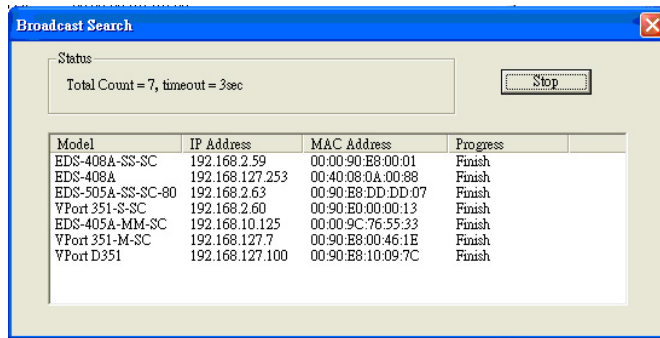

- When the search has ended, the Model Name, MAC address, and IP address of the EDS switches and the VPorts will be listed in the **Utility** window.

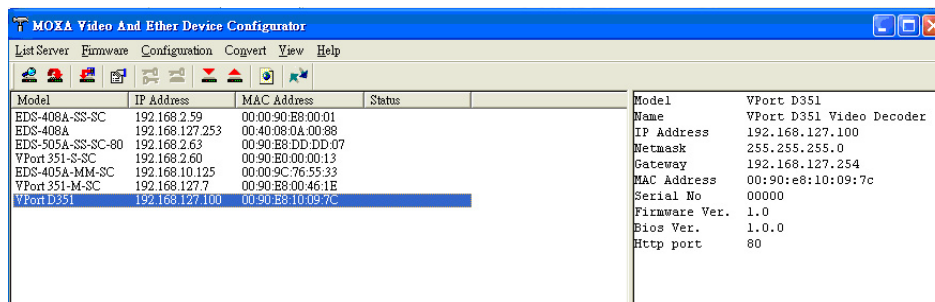

NOTE Broadcast Search can only search for devices connected to the same LAN domain as the VPort. If your devices are located on a different LAN domain, use the Specify IP Address function to search for the device by keying in the IP address.

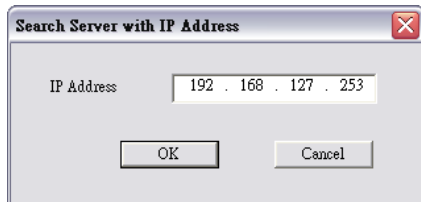

- Double click the selected VPort, or use the IE web browser to access the VPort’s web-based manager (web console).

Network Environment without DHCP Server

If your VPort D361 is connected to a network that does not have a DHCP server, you will need to configure the IP address manually. The default IP address of the VPort D361 is **192.168.127.100** and the default subnet mask is 255.255.255.0. Note that you may need to change your computer’s IP address and subnet mask so that the computer is on the same subnet as the VPort.

To change the IP address of the VPort manually, access the VPort’s web server, and then navigate to the **System Configuration → Network → General page** to configure the IP address and other network settings. Check the **Use fixed IP address** checkbox to ensure that the IP address you assign is not deleted each time the VPort is restarted.

Step 7: Accessing the VPort D361 Web-based Manager

1. Type the IP address in the web browser’s address input box and then press enter to connect to the homepage of the VPort D361’s web-based manager.

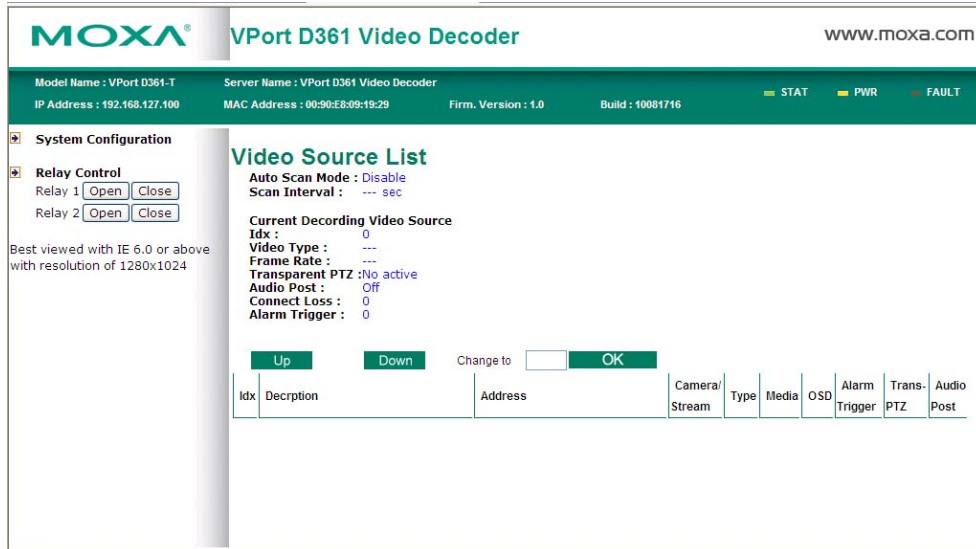

NOTE Once the VPort D361’s homepage opens, The Administrator can go to **System Configuration → System → Account** to set up the Administrator’s password. After that, an authentication window will open to request that the Administrator input the account name, admin, and the new password.

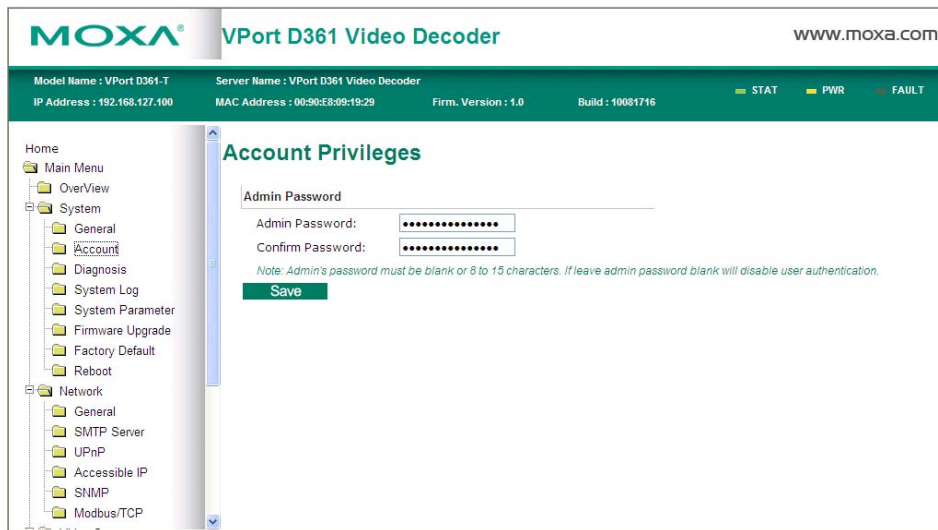

Step 8: Accessing the VPort’s System Configuration

Click on **System Configuration** to access the overview of the system configuration to change the configuration. **Model Name, Server Name, IP Address, MAC Address, Firmware Version, and LED Status** appear in the green bar near the top of the page. Use this information to check the system information

and installation. For details of each configuration, refer to Chapter 4, **System Configuration**.

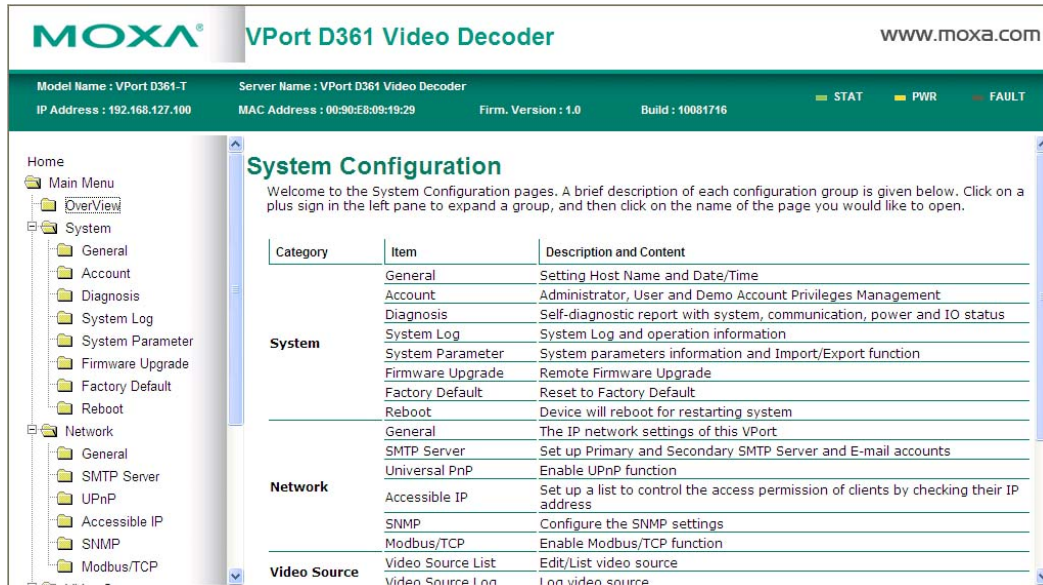

The screenshot shows the Moxa VPort D361 Video Decoder web interface. The top header displays the Moxa logo, the device name 'VPort D361 Video Decoder', and the website 'www.moxa.com'. Below the header, a status bar shows the Model Name (VPort D361-T), Server Name (VPort D361 Video Decoder), IP Address (192.168.127.100), MAC Address (00:90:E8:09:19:29), Firm. Version (1.0), and Build (10081716). There are also indicators for STAT, PWR, and FAULT.

The main content area is titled 'System Configuration' and includes a welcome message: 'Welcome to the System Configuration pages. A brief description of each configuration group is given below. Click on a plus sign in the left pane to expand a group, and then click on the name of the page you would like to open.'

Category	Item	Description and Content
System	General	Setting Host Name and Date/Time
	Account	Administrator, User and Demo Account Privileges Management
	Diagnosis	Self-diagnostic report with system, communication, power and IO status
	System Log	System Log and operation information
	System Parameter	System parameters information and Import/Export function
	Firmware Upgrade	Remote Firmware Upgrade
	Factory Default	Reset to Factory Default
	Reboot	Device will reboot for restarting system
Network	General	The IP network settings of this VPort
	SMTP Server	Set up Primary and Secondary SMTP Server and E-mail accounts
	Universal PnP	Enable UPnP function
	Accessible IP	Set up a list to control the access permission of clients by checking their IP address
	SNMP	Configure the SNMP settings
Video Source	Modbus/TCP	Enable Modbus/TCP function
	Video Source List	Edit/List video source
	Video Source Log	Log video source

RS-232 Console Configuration (115200, None, 8, 1, VT100)

NOTE Connection Caution!

1. You **cannot** connect to the VPort D361 simultaneously by serial console and Telnet.
2. You **can** connect to VPort D361 simultaneously by web browser and serial console, or by web browser and Telnet.

We strongly recommend that you do NOT use more than one connection method at the same time.

Following this advice will allow you to maintain better control over the configuration of your VPort D361.

NOTE We recommend using Moxa PComm Terminal Emulator, which can be downloaded free of charge from Moxa's website.

Before running PComm Terminal Emulator, use an RJ45-to-DB9-F (or RJ45-to-DB25-F) cable to connect the VPort D361's RS-232 console port to your PC's COM port (generally COM1 or COM2, depending on how your system is set up).

After installing PComm Terminal Emulator, perform the following steps to access the RS-232 console utility.

1. From the Windows desktop, click **Start → Programs → PCommLite2.5 → Terminal Emulator**.

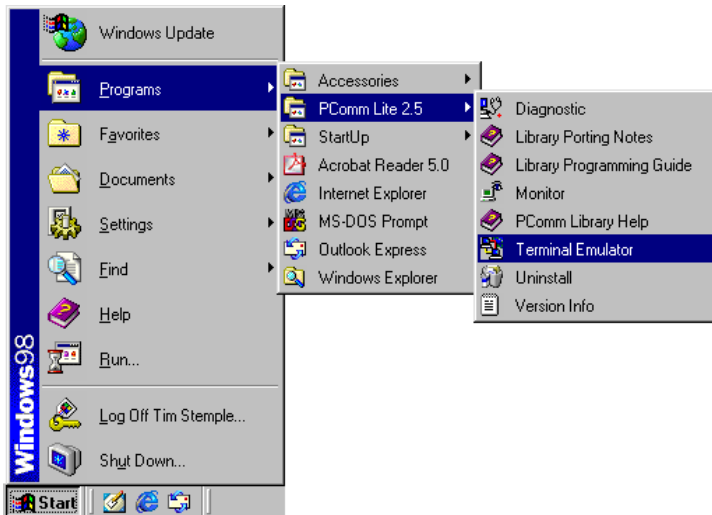

2. Select **Open** under **Port Manager** to open a new connection.

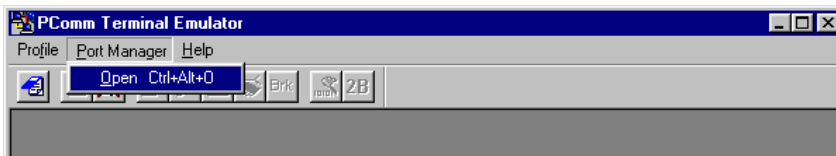

3. The **Communication Parameter** page of the **Property** window opens. Select the appropriate COM port for Console Connection, **115200** for **Baud Rate**, **8** for **Data Bits**, **None** for **Parity**, and **1** for **Stop Bits**.

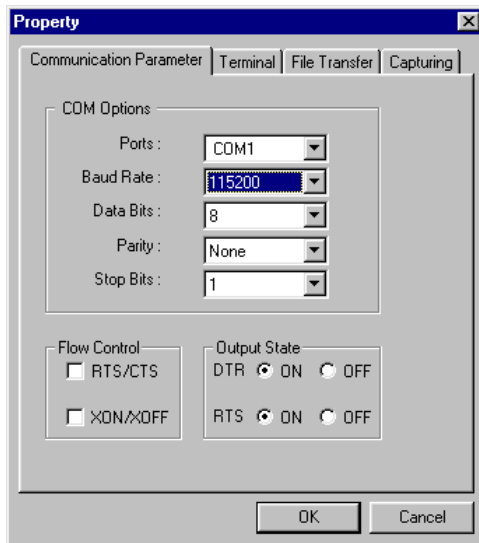

- Click the **Terminal** tab, and select **VT100** for **Terminal Type**. Click **OK** to continue.

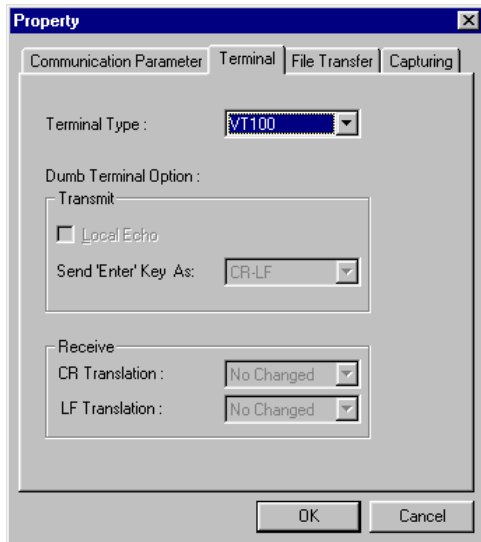

- A blank screen will appear. Press **Enter** to display a login message for authentication. Only the Administrator is allowed to use this console configuration. For this reason, use **admin** as the username and **admin's password** as the password, and then press **Enter**.

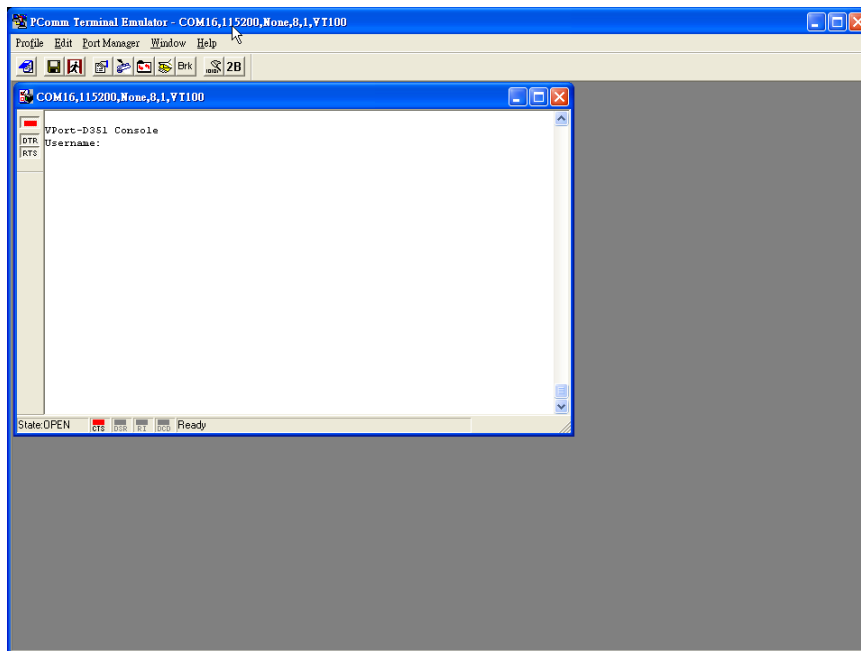

- The VPort D361's console **Main Menu** will appear. (NOTE: To modify the appearance of the PComm Terminal Emulator window, select **Font...** under the **Edit** menu, and then choose the desired formatting options.)

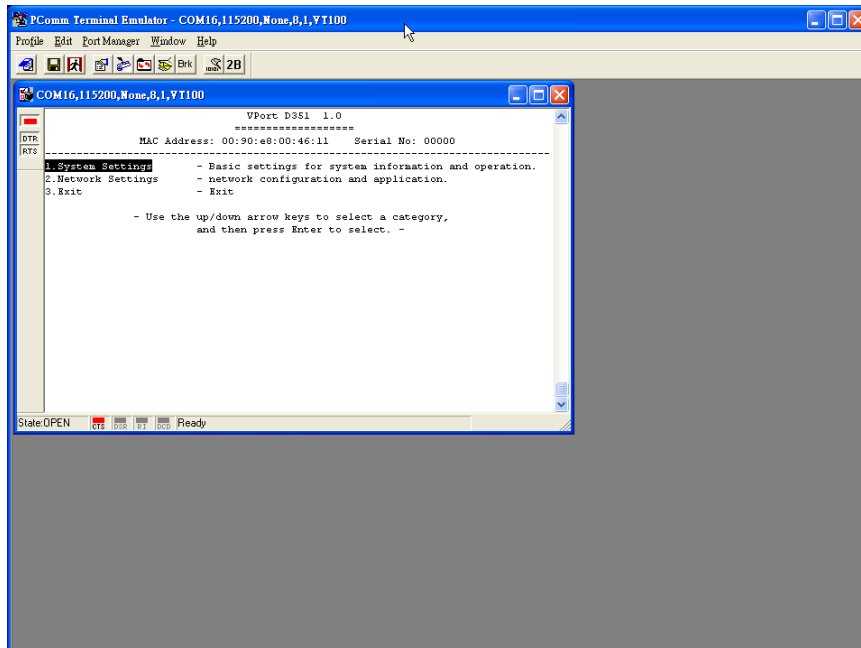

- After entering the **Main Menu**, use the following keys to move the cursor, and to select options.

Key	Function
Up/Down/Left/Right arrows, or Tab	Move the onscreen cursor
Enter	Display & select options
Space	Toggle options
Esc	Previous Menu

Mounting the VPort D361

Mounting Dimensions (unit= mm)

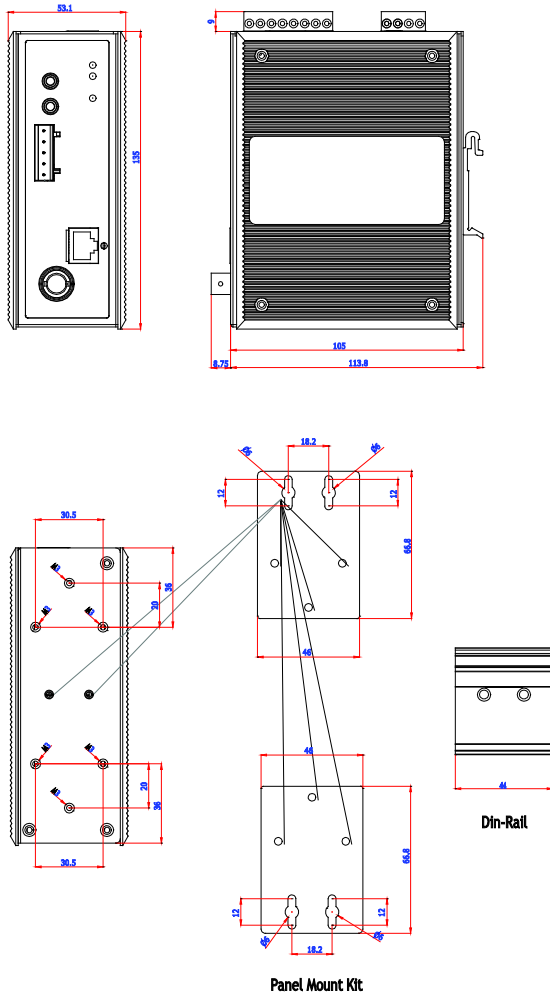

DIN-Rail Mounting

The aluminum DIN-Rail attachment plate should already be attached to the rear panel of the VPort D361 when you take it out of the box. If you need to reattach the DIN-Rail attachment plate to the VPort D361, make sure the stiff metal spring is situated towards the top, as shown in the figures below.

STEP 1:

Insert the top of the DIN-Rail into the slot just below the stiff metal spring.

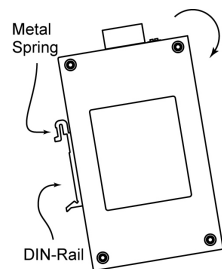

STEP 2:

The DIN-Rail attachment unit will snap into place as shown below.

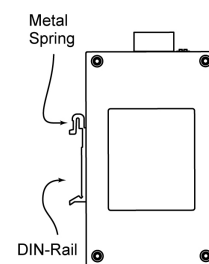

To remove the VPort D361 from the DIN-Rail, simply reverse Steps 1 and 2 above.

Wall Mounting (Optional)

For some applications, you will find it convenient to mount the VPort D361 on the wall, as shown in the diagrams below.

STEP 1:

Remove the aluminum DIN-Rail attachment plate from the VPort 351, and then attach the wall mounting plates, as shown in the diagrams below.

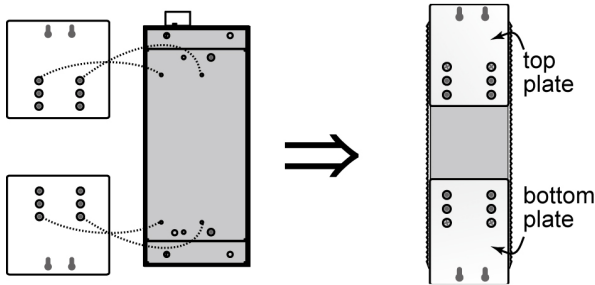

STEP 2:

Mounting the VPort D361 on the wall requires 4 screws. Use the VPort D361, with wall mount plates attached, as a guide to mark the correct locations of the 4 screws. The heads of the screws should be less than 6.0 mm in diameter, and the shafts should be less than 3.5 mm in diameter, as shown in the figure at the right. Do not screw the screws in all the way—leave a space of about 2 mm to allow room for sliding the wall mount panel between the wall and the screws.

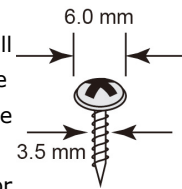

NOTE Test the screw head and shank size by inserting the screw into one of the keyhole shaped apertures of the wall mounting plates before it is screwed into the wall.

STEP 3:

Once the screws are fixed in the wall, insert the four screw heads through the large parts of the keyhole-shaped apertures, and then slide the VPort D361 downwards, as indicated in the figure. Tighten the four screws for added stability.

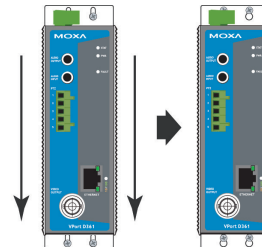

Wiring Requirements



ATTENTION

Safety First!

Be sure to disconnect the power cord before installing and/or wiring your Moxa VPort D361. Calculate the maximum possible current in each power wire and common wire. Observe all electrical codes dictating the maximum current allowable for each wire size. If the current goes above the maximum ratings, the wiring could overheat, causing serious damage to your equipment.

You should also pay attention to the following:

- Use separate paths to route wiring for power and devices. If power wiring and device wiring paths must cross, make sure the wires are perpendicular at the intersection point.

NOTE: Do not run signal or communications wiring and power wiring in the same wire conduit. To avoid interference, wires with different signal characteristics should be routed separately.

- You can use the type of signal transmitted through a wire to determine which wires should be kept separate. The rule of thumb is that wiring that shares similar electrical characteristics can be bundled together.
- Keep input wiring and output wiring separated.
- We strongly advised that you label the wires to all devices in the system when necessary.

Grounding the VPort D361

Grounding and wire routing help limit the effects of noise caused by electromagnetic interference (EMI). Run the ground connection from the ground screw to the grounding surface prior to connecting devices.



ATTENTION

This product is intended to be mounted to a well-grounded mounting surface such as a metal panel.

Wiring the Relay Output

The VPort D361 has two sets of relay output—relay 1 and relay 2—located on the 8-pin terminal block connector. Each relay output consists of the 3 contacts of the terminal block on the VPort D361's top panel.

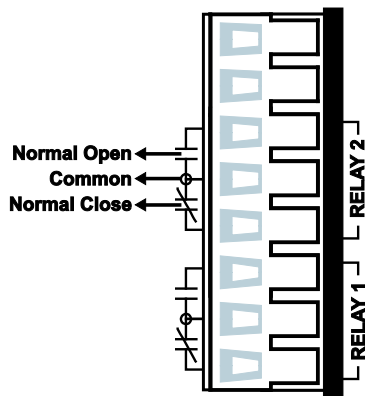

The Relay Output can be set up for:
 System alarm: In this case, network disconnected.
 Event alarm: Digital inputs.



ATTENTION

The current and power capacity of the relay output is a maximum of 24 VDC @ 1A. You should be careful not to exceed this power specification.



ATTENTION

Before connecting the VPort to the DC/AC power inputs, make sure the voltage from the DC power source is stable.

Wiring the Power Input

The VPort D361 has one power input located on the 8-pin terminal block connector. The top and the front views of the terminal block connectors are shown here.

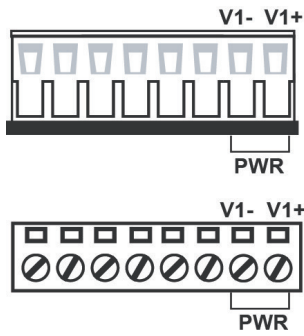

- STEP 1:** Insert the negative/positive DC or AC wires into the V-/V+ terminals.
- STEP 2:** To keep the DC or AC wires from pulling loose, use a small flat-blade screwdriver to tighten the wire-clamp screws on the front of the terminal block connector.
- STEP 3:** Insert the plastic terminal block connector prongs into the terminal block receptor, which is located on VPort D361's top panel.



ATTENTION

The power for this product is intended to be supplied by a Listed Power Unit, with output marked LPS, and rated to deliver 12 to 32 VDC at a maximum of 540 mA, or 18 to 30 VAC at a maximum of 360 mA.

Wiring the Digital Inputs

The VPort D361 has two sets of digital inputs—DI 1 and DI 2. Each DI consists of two contacts of the 6-pin terminal block connector on the VPort's top panel. Top and front views of one of the terminal block connectors are shown here.

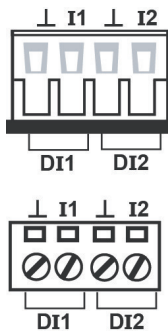

- STEP 1:** Insert the negative (ground)/positive DI wires into the -I/I1 terminals.
- STEP 2:** To keep the DI wires from pulling loose, use a small flat-blade screwdriver to tighten the wire-clamp screws on the front of the terminal block connector.
- STEP 3:** Insert the plastic terminal block connector prongs into the terminal block receptor, which is located on the VPort D361's top panel.

The VPort D361's DI 1 and DI 2 can also be used for controlling the selection of the video source. The Administrator can set up this function by checking the **Enable DI Change** checkbox under **System Configuration/Video Source/Video Source List**. The DI 1 can then do backward video source selection (e.g., from video source 2 to video source 1), and DI 2 can do forward video source selection (e.g., from video source 1 to video source 2).

Communication Connections

10/100BaseT(X) Ethernet Port Connection

The 10/100BaseT(X) port located on the VPort D361's front panel is used to connect to Ethernet-enabled devices.

Below we show pinouts for both the MDI (NIC-type) port and MDI-X (HUB/Switch-type) port, and we also show cable wiring diagrams for straight-through and cross-over Ethernet cables.

Auto MDI/MDI-X

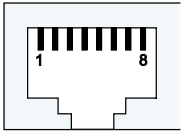
(MDI) Port Pinouts		(MDI-X) Port Pinouts		8-pin RJ45
Pin	Signal	Pin	Signal	
1	Tx+	1	Rx+	
2	Tx-	2	Rx-	
3	Rx+	3	Tx+	
6	Rx-	6	Tx-	

RJ45 (8-pin) to RJ45 (8-pin) Straight-through Cable Wiring

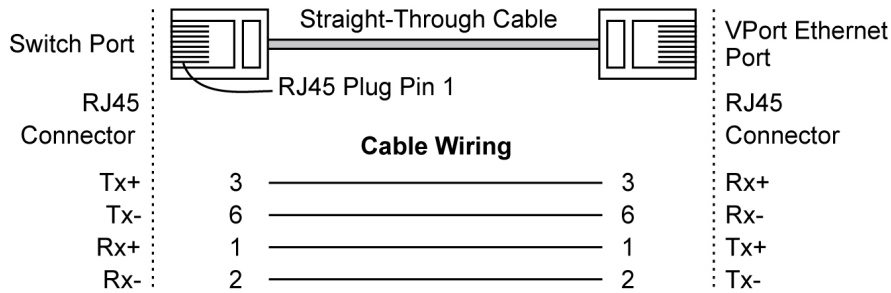

RJ45 (8-pin) to RJ45 (8-pin) Cross-over Cable Wiring

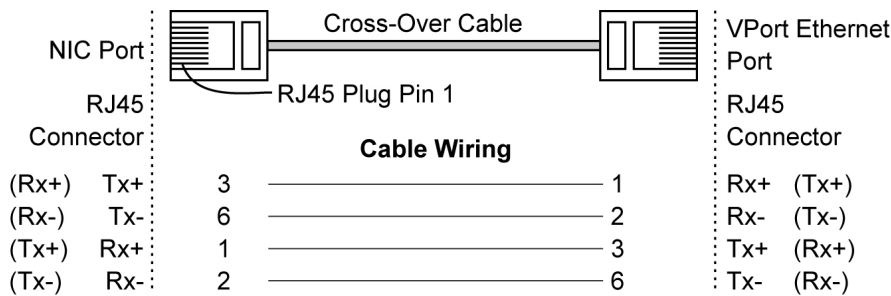

3

Accessing VPort D361's Web-based Manager

This chapter includes information about how to access VPort D361 Video Decoder for the first time.

The following topics are covered in this chapter:

▣ **Functions Featured on the VPort's Web Homepage**

- Basic VPort's Information
- Current Video Source information
- Video Source Selection
- Video Source List
- System Configuration
- Relay Control

Functions Featured on the VPort's Web Homepage

The homepage of the VPort's Web-based Manager shows basic information about the VPort, camera image view, and configurations for client and server.

NOTE For best viewing, use 1280 x 1024 resolution when viewing the VPort's web homepage.

VPort's Information

This section shows the VPort's model name, server name, IP address, MAC address, firmware version, and the display status of the LEDs located on the VPort's front panel.

NOTE The VPort LEDs shown on the VPort's web homepage are updated every 10 seconds.

Current Video Source Information

This section presents the video sources' display modes, and information related to the video source currently being displayed. The Administrator can access **System Configuration/video source** to modify the configurations.

Video Source Selection

For convenience, buttons are available for manually selecting the specified video source. The Administrator can use the **UP** and **DOWN** buttons to change the video source one by one, or directly input the Idx (index) number of the video source.

Video Source List

A maximum of 64 video sources can be added to the VPort D361's video source list. The following parameters can be modified:

1. **Idx**: video source index.
2. **Source Description**: customized video source description.
3. **Address**: IP address or domain name of the video source; the Administrator can click on the address to link to the video source's web-based manager page.
4. **Camera Idx**: camera index of the video source.

5. **Media:** decode video and audio, video only, or audio only.
6. **OSD:** enable or disable the OSD (on-screen display).
7. **Alarm trigger:** enable or disable the function that automatically switches the video source upon alarm activation.
8. **Transparent PTZ Control:** enable or disable transparent PTZ function control.
9. **Audio post:** when enabled, users can both view the video source and hear the audio; when disabled, only the video is available.

System Configuration

A button or text link on the left side of the system configuration window only appears on the Administrator's main page. For detailed system configuration instructions, refer to Chapter 4, **System Configuration**.

Relay Control

The VPort D361 has 2 relay outputs for external devices, such as alarms. The Administrator and users who have been given access can click on **Open** to short the **Common** and **Normal Open** digital output pins, or click on **Close** to short the **Common** and **Normal Close** digital output pins.

System Configuration

After installing the hardware, the next step is to configure the VPort D361's settings. The web-based manager can be used to access configuration options.

The following topics are covered in this chapter:

▣ Using the Web-based Manager for System Configuration

- System
- Network
- Video Source
- Video
- Audio
- Transparent PTZ
- Alarm

Using the Web-based Manager for System Configuration

System configuration can be done remotely with Internet Explorer through the web server. Alternatively, the Administrator may type the system configuration URL, **http://<IP address of Video Server>/setup/config.html**, to enter the configuration page directly. Five categories of configuration are involved in configuring the system: **System, Network, Video, Audio, and Alarm**. A description of each configuration item is shown in the table below:

Category	Item	Description and Contents	
System	General	Set Host Name and Date/Time	
	Accounts	Administrator Account Privileges Management	
	Diagnosis	Self-diagnostic report with system, communication, power, and IO status	
	System Log	System Log and operation information	
	System Parameter	System parameters information and Import and Export functions	
	Firmware Upgrade	Remote Firmware Upgrade	
	Factory Default	Reset to Factory Default	
	Reboot	Reboot the VPort	
Network	General	The IP network settings of this VPort	
	SMTP Server	Set up Primary and Secondary SMTP Server and e-mail accounts	
	Universal PnP	Enable UPnP function	
	Multicast	Set up Multicast (IGMP) streaming	
	Accessible IP	Set up a list to control the access permission of clients by checking their IP address	
	SNMP	Configure the settings of SNMP	
Video Source	Video Source List	Edit and list video sources	
	Video Source Log	Log video sources	
Video	OSD Settings	Configure the OSD strings of the video images	
	Video Output	Select the video's modulation (NTSC, PAL)	
Audio	Audio Setting	Configure the Audio Input/Output settings	
Transparent PTZ	Transparent PTZ Setting	Configure the Transparent PTZ	
Alarm	Relay Setting	Setup the relay output status	
	System Alarm	Configure Power Failure and Network Connection Broken alarms	
	Event Alarm	Basic	General settings of event alarm
		Schedule	Set up the Alarm schedule
	Digital Input	Configure the Digital Input alarm	

This table also appears on the **System Configuration** → **Overview** webpage.

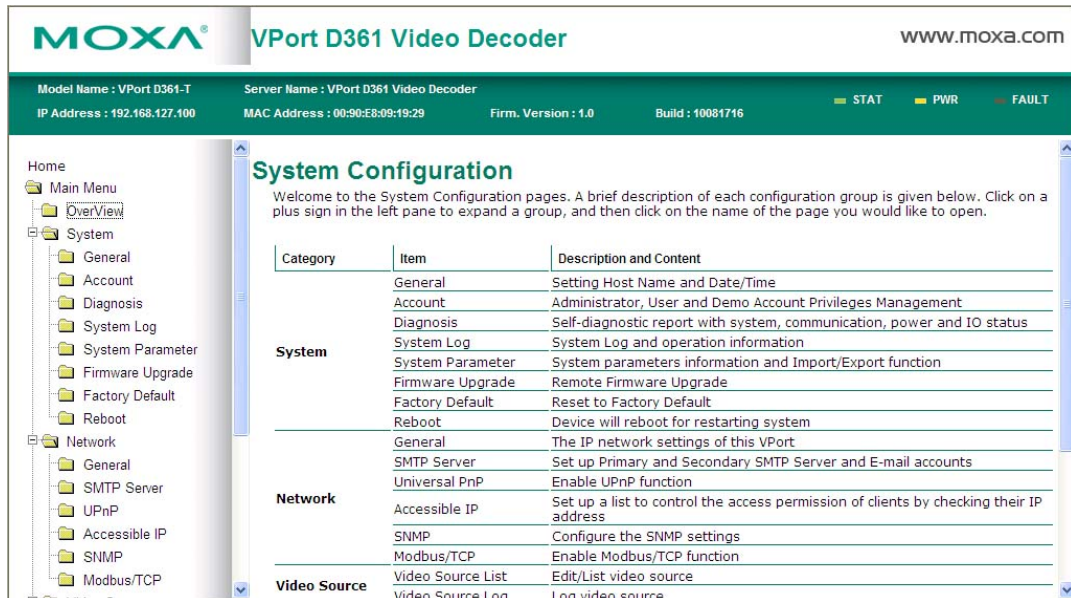

System

General Settings

On the **General Settings** page, the Administrator can set up the video **Server name** and the **Date and Time**, which appear in caption for the image.

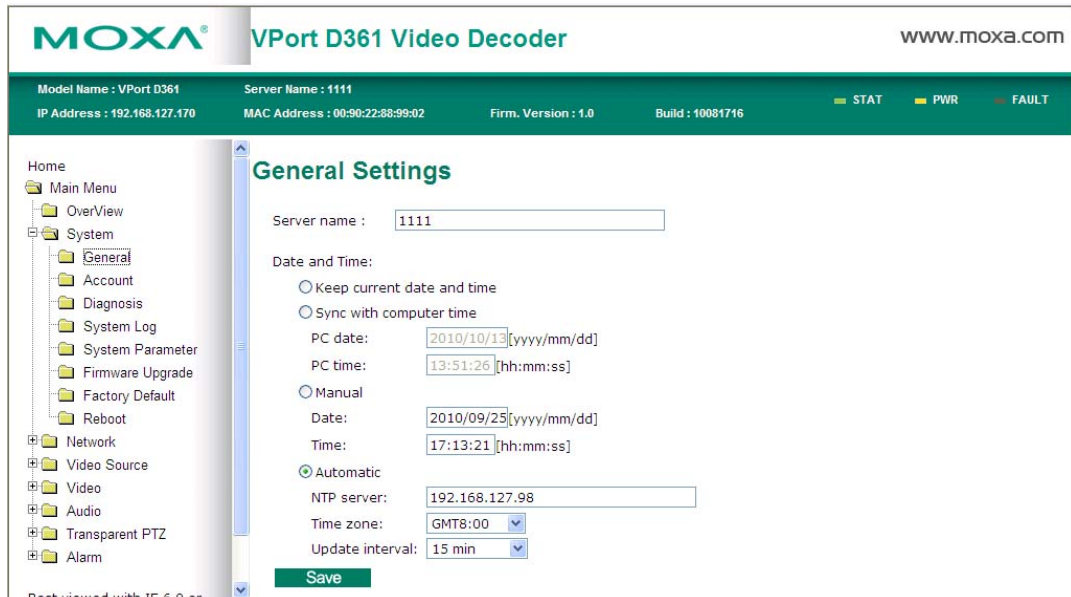

Server name

Setting	Description	Default
Max. 40 characters	Give a different server name for each server to help identify the different servers. The name appears on the web homepage.	VPort D361 Video Decoder

Date and Time

Setting	Description	Default
Keep current date and time	Use the current date and time as the VPort's time settings.	Keep current date and time
Sync with computer time	Synchronize the VPort's date and time settings with the local computer time.	

Manual	Manually change the VPort's date and time settings.	
Automatic	Use the NTP server to change the VPort's date and time settings in a given period.	

NOTE Select the Automatic option to force the VPort to synchronize automatically with timeservers over the Internet. However, synchronization may fail if the assigned NTP server cannot be reached, or the VPort is connected to a local network. Leaving the NTP server blank will force the VPort to connect to default timeservers. Enter either the Domain name or IP address format of the timeserver if the DNS server is available.

Don't forget to set the Time zone for local settings. Refer to Appendix G, **Time Zone Table**.

Account Privileges

The VPort D361 only allows the Administrator to access the web-based manager.

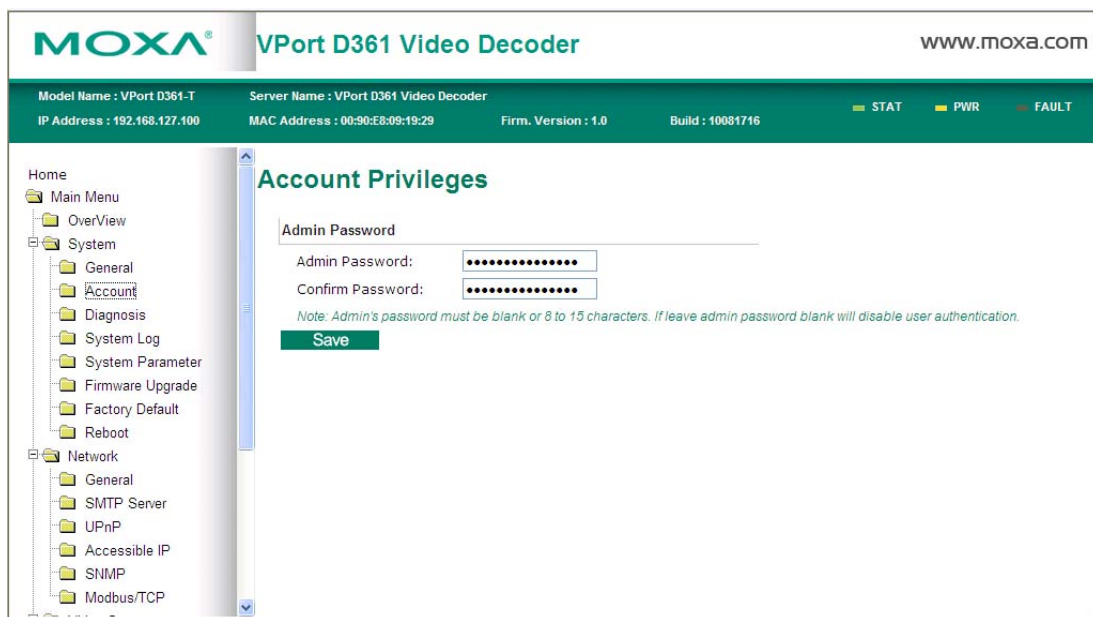

Admin password

Setting	Description	Default
Admin Password (max. 14 characters)	The Administrator can type the new password in this box.	None
Confirm Password (max. 14 characters)	If a new password is typed in the Admin Password box, you will need to retype the password in the Confirm Password box before updating the new password.	

NOTE The default account name for the Administrator is admin; the Administrator account name cannot be changed.

System Diagnosis

The VPort products have a self-diagnosis function to let the Administrator get a quick view of the system and connection status. The Administrator can save this diagnosis information in a file (diagnosis.log) by clicking the **Export to a File** button, or sending the file by e-mail by clicking the **Send a Report via Email** button.

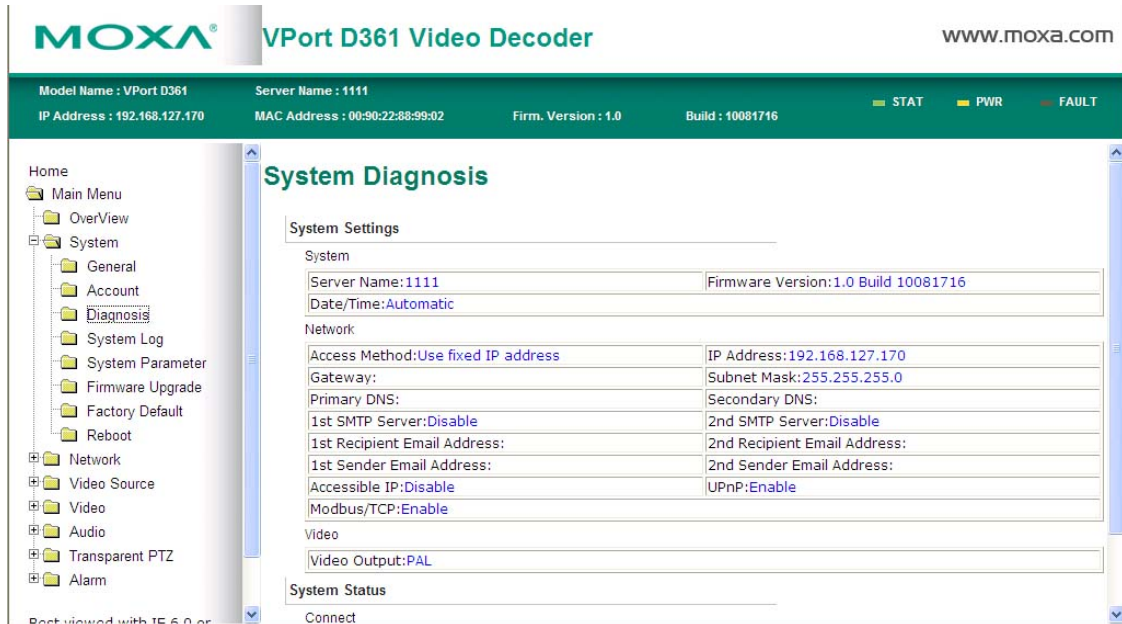

System Log History

The system log contains useful information, including current system configuration and activity history with timestamp for tracking. The Administrator can save this information in a file (system.log) by clicking **Export to a File** button, or send the file by email by clicking the **Send a Report via Email** button, or clear the log by clicking the **Clear** button.

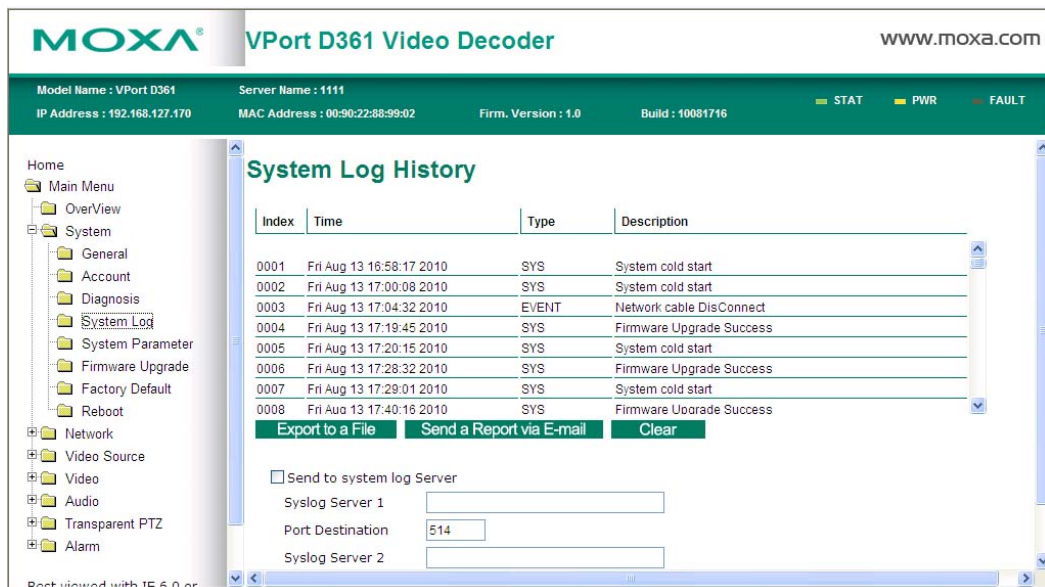

System Parameters

The **System Parameters** page allows you to view all system parameters, which are listed by category. The Administrator can save this information in a file (sys_config.ini) by clicking the **Export to a File** button, or

import a file by clicking the **Browse** button to search a sys_config.ini file, and then click the **Import a System Parameter File** button to update all the system configurations quickly.

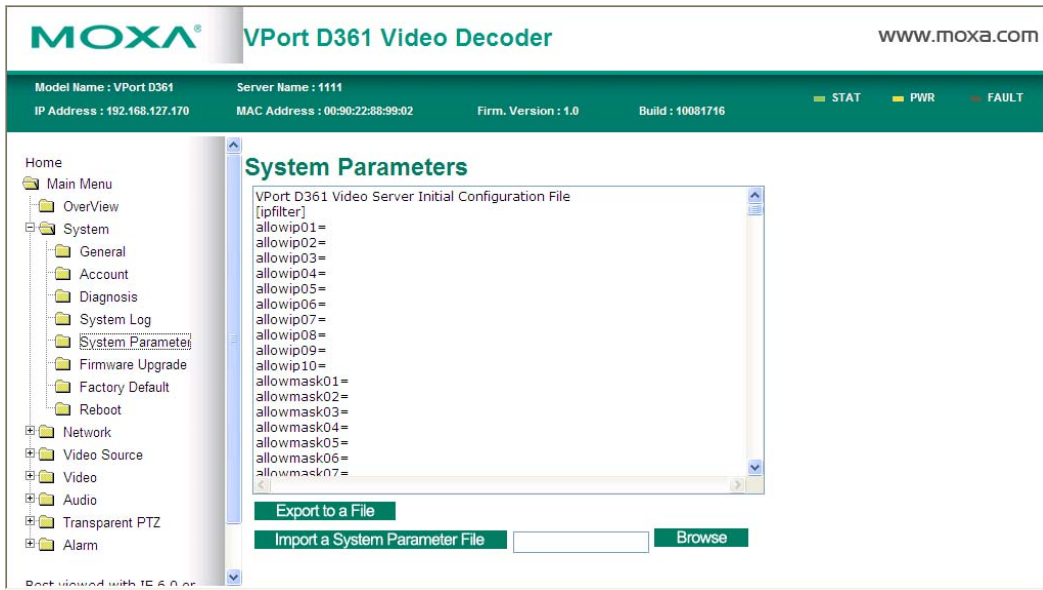

NOTE The system parameter import/export functions allow the Administrator to back up and restore system configurations. The Administrator can export this sys_config.ini file (in a special binary format) for backup, and import the sys_config.ini file to restore the system configurations of the VPort. System configurations will be changed immediately after the VPort is rebooted.

Firmware Upgrade

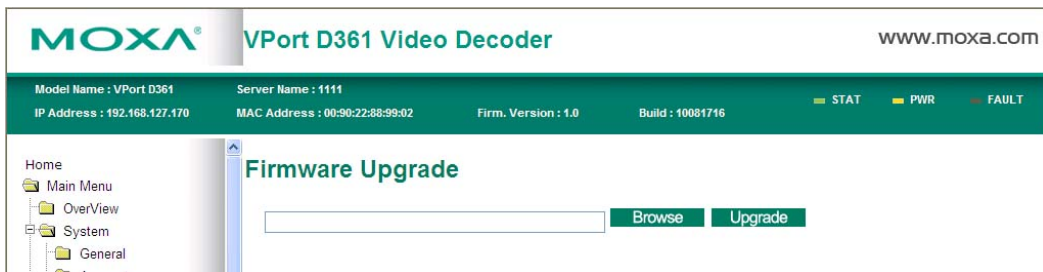

Take the following steps to upgrade the firmware:

Step 1: Press the **Browse** button to select the firmware file.

NOTE For the VPort D361, the firmware file extension should be .rom.

Step 2: Click on the **Upgrade** button to upload the firmware to the VPort.

Step 3: The system will start the firmware upgrade process.

Step 4: Once **Firmware Update Success.....Reboot....** is shown, wait a few seconds for the VPort to reboot. The reboot process is finished once the **STAT** LED is lit continuously in green.

NOTE Firmware upgrade will not change the original settings.

Reset to Factory Default

Reset to the factory default by clicking on the **OK** button (as shown in the following figure).

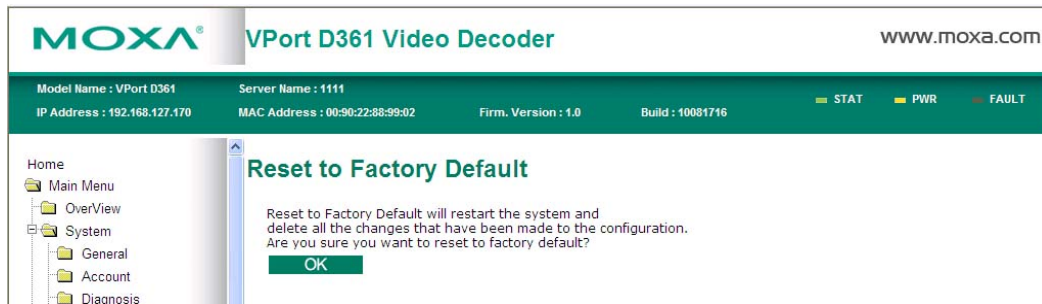

NOTE All parameters will be reset to factory defaults when you use the Factory Default function. For this reason, if you want to keep a digital copy of the current configuration, remember to export the sys_config.ini file before using the Factory Default function.

Reboot

From the "Device Reboot" page, click **OK** (as shown in the following figure) to restart the VPort's operating system.

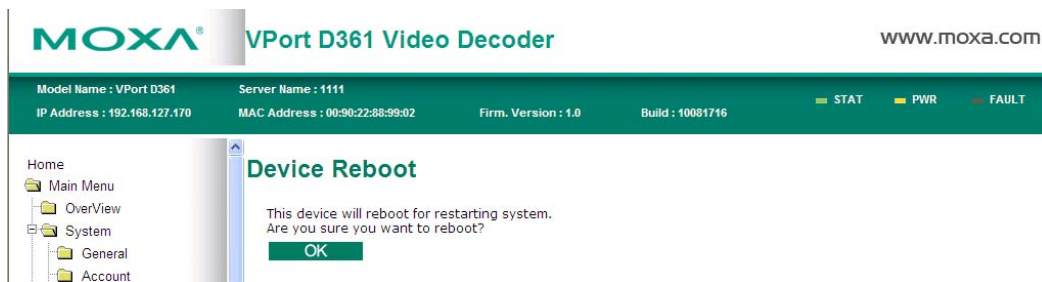

Network

General Network Settings

The **General Network Settings** page includes some basic but important network configurations that enable the VPort to be connected to a TCP/IP network.

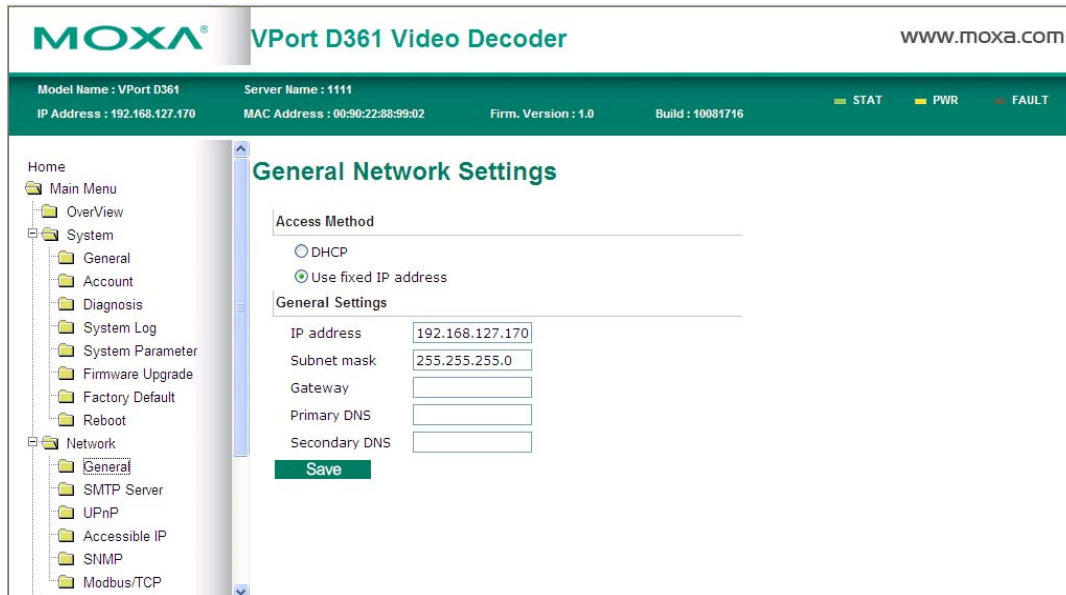

Access Method

The VPort products support the DHCP protocol, which means that the VPort can get its IP address from a DHCP server automatically when it is connected to the TCP/IP network. The Administrator should determine if it is more appropriate to use DHCP, or assign a fixed IP.

Setting	Description	Default
DHCP	The VPort gets the IP address automatically from the DHCP server.	Get IP address automatically
Use fixed IP address	Uses the IP address assigned by the Administrator.	

NOTE We strongly recommend that the Administrator assign a fixed IP address to the VPort, since all of the functions and applications provided by the VPort are active when the VPort is connected to the network. Use DHCP to determine if the VPort’s IP address may change when then network environment changes, or the IP address is occupied by other clients.

General Settings

Setting	Description	Default
IP address	Variable IP assigned automatically by the DHCP server, or fixed IP assigned by the Administrator.	192.168.127.100
Subnet mask	Variable subnet mask assigned automatically by the DHCP server, or a fixed subnet mask assigned by the Administrator.	255.255.255.0
Gateway	Assigned automatically by the DHCP server, or assigned by the Administrator.	blank
Primary DNS	Enter the IP address of the DNS Server used by your network. After entering the DNS Server’s IP address, you can input the VPort’s url (e.g., www.VPort.company.com) in your browser’s address field, instead of entering the IP address.	Gotten automatically from the DHCP server, or blank in non-DHCP environment
Secondary DNS	Enter the IP address of the DNS Server used by your network. The VPort will try to locate the secondary DNS Server if the primary DNS Server fails to connect.	Gotten automatically get from the DHCP server, or left blank in a non-DHCP environment

SMTP Server and Email Account Settings

The VPort not only plays the role of server, but can also connect to outside servers to send system or alarm messages. If the Administrator has set up some applications in either system information or alarm, the VPort will send out messages or snapshots once these conditions occur.

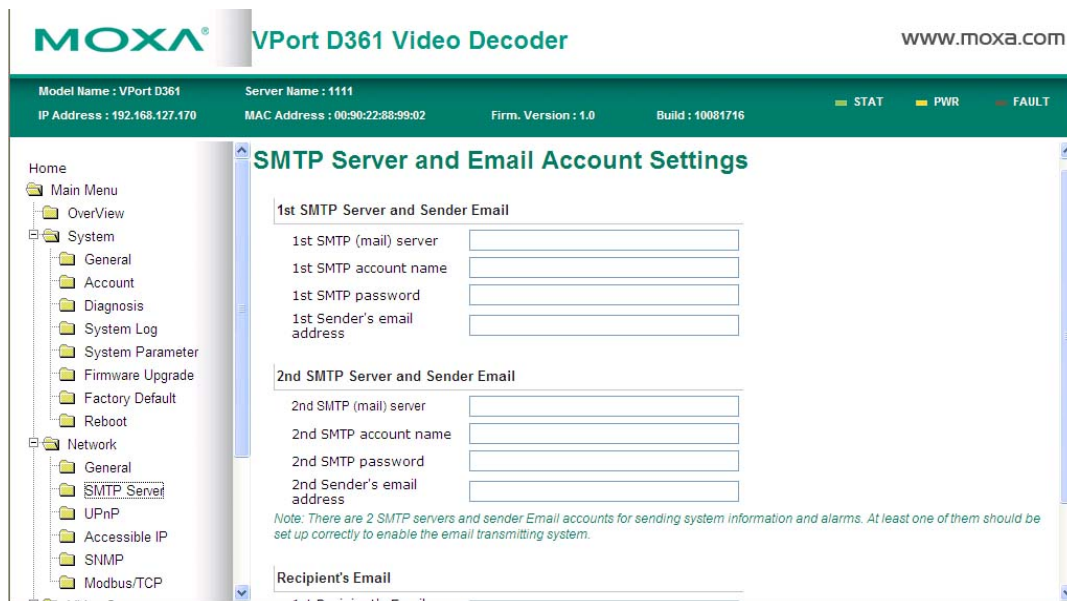

1st SMTP Server and Sender Email

Setting	Description	Default
1st SMTP (mail) server	SMTP Server's IP address or URL address.	None
1st SMTP account name	For security reasons, most SMTP servers require the account name and password to be authenticated.	None
1st SMTP password		None
1st Sender's email address	For security reasons, SMTP servers require the exact sender's e-mail address.	None

NOTE Note that if the Sender's e-mail address is not set, a warning message will pop up and the e-mail system will not be allowed to operate.

NOTE The 2nd SMTP Server and Sender Email are backups that are used if the 1st SMTP Server and Sender Email fail when connecting or sending e-mails.

Two recipient's e-mail accounts are available for receiving emails sent by the VPort. For redundancy, both addresses receive the messages and alarm snapshots simultaneously.

Setting	Description	Default
1st Recipient's Email Address	Email address of the 1st recipient.	None
2nd Recipient's Email Address	Email address of the 2nd recipient.	None

Universal PnP

UPnP (Universal Plug & Play) is a networking architecture that provides compatibility between networking equipment, software, and peripherals of the 400+ vendors that are part of the Universal Plug and Play Forum. The UPnP devices are listed in the network devices table from the operating system (such as Windows XP). Users can link to the VPort directly by clicking on the VPort listed in the network devices table.

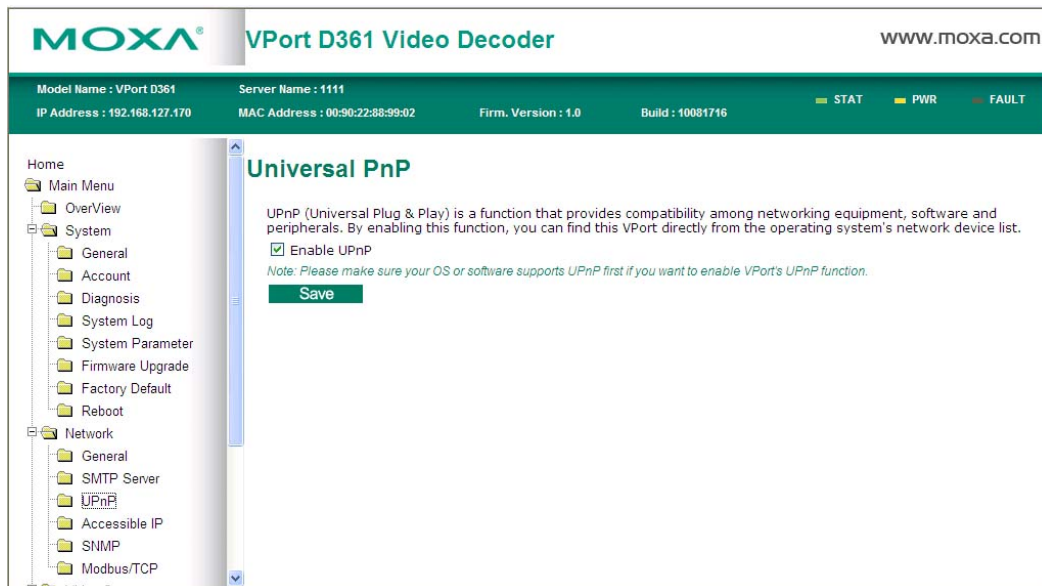

Setting	Description	Default
Enable UPnP	Enable or disable the UPnP function.	Enable

Accessible IP List

The VPort D361 uses an IP address-based filtering method to control access to the VPort.

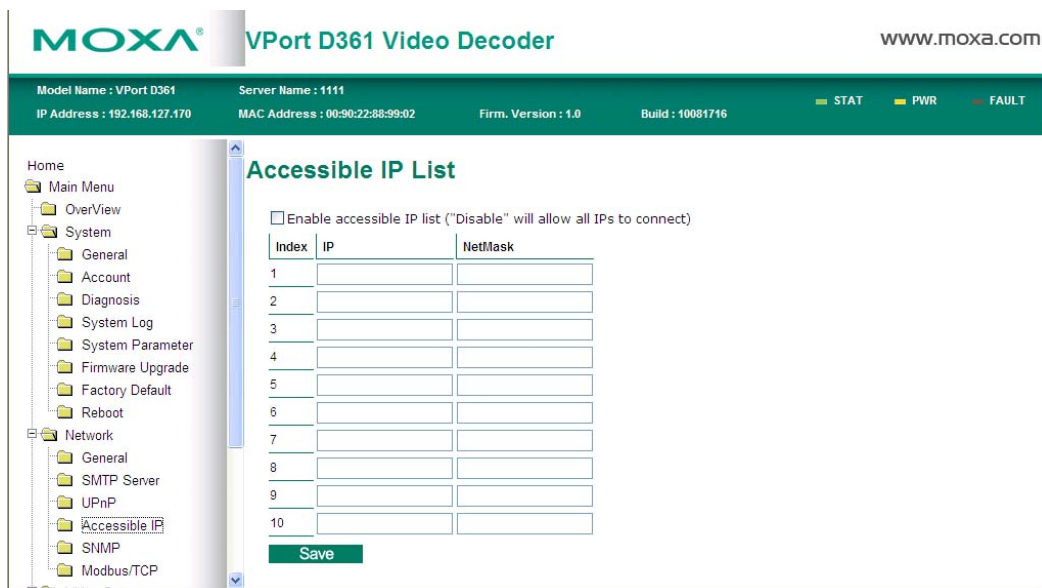

Accessible IP Settings allows you to add or remove “Legal” remote host IP addresses to prevent unauthorized access. Access to the VPort is controlled by IP address. That is, if a host’s IP address is in the accessible IP table, then the host will be allowed access to the VPort. The Administrator can allow one of the following cases by setting this parameter:

- Only one host with a specific IP address can access the VPort.
Enter “IP address/255.255.255.255” (e.g., 192.168.1.1/255.255.255.255)
- Hosts on a specific subnet can access the VPort.
Enter “IP address/255.255.255.0” (e.g., “192.168.1.0/255.255.255.0”)
- Any host can access the VPort.
Disable this function.

Refer to the following table for more configuration examples.

Allowable Hosts	Input Formats
Any host	Disable
192.168.1.120	192.168.1.120/255.255.255.255
192.168.1.1 to 192.168.1.254	192.168.1.0/255.255.255.0
192.168.0.1 to 192.168.255.254	192.168.0.0/255.255.0.0
192.168.1.1 to 192.168.1.126	192.168.1.0/255.255.255.128
192.168.1.129 to 192.168.1.254	192.168.1.128/255.255.255.128

SNMP

The VPort supports three SNMP protocols. The available protocols are SNMP V1, SNMP V2c, and SNMP V3. The SNMP V1 and SNMP V2c protocols use a community string match for authentication, which means that SNMP servers access all objects with read-only or read/write permissions using the community string public/private (default value). The SNMP V3 protocol, which requires you to select an authentication level of MD5 or SHA, is the most secure protocol. You can also enable data encryption to enhance data security. SNMP security modes and security levels supported by the VPort are shown in the following table. Select one of these options to communicate between the SNMP agent and manager.

Protocol Version	Security Mode	Authentication Type	Data Encryption	Method
SNMP V1, V2c	V1, V2c Read Community	Community string	No	Use a community string match for authentication
	V1, V2c Write/Read Community	Community string	No	Use a community string match for authentication
SNMP V3	No-Auth	No	No	Use the Administrator account or user account to access objects
	MD5 or SHA	MD5 or SHA	No	Provides authentication based on HMAC-MD5, or HMAC-SHA algorithms. 8-character passwords are the minimum requirement for authentication.
	MD5 or SHA	MD5 or SHA	Data encryption key	Provides authentication based on HMAC-MD5 or HMAC-SHA algorithms, and data encryption key. 8-character passwords and a data encryption key are the minimum requirements for authentication and encryption.

Configuring SNMP Settings

The following figures indicate which SNMP parameters can be configured. A more detailed explanation of each parameter is given below the figure.

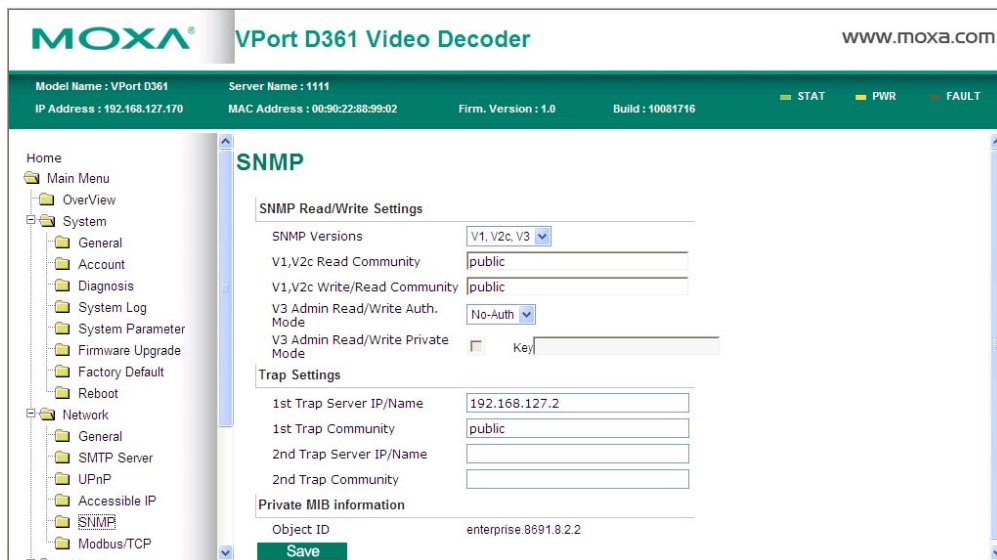

SNMP Read/Write Settings

SNMP Versions

Setting	Description	Default
V1, V2c, V3	Select SNMP Versions V1, V2c, V3 protocol to manage the switch	V1, V2c
V1, V2c	Select SNMP Versions V1, V2c protocol to manage the switch	
V3 only	Select SNMP Versions V3 protocol only to manage the switch	

V1, V2c Read Community

Setting	Description	Default
V1, V2c Read Community	Use a community string match for authentication, which means that the SNMP agent accesses all objects with read-only permissions using the community string public.	public (max. 30 characters)

V1, V2c Read/Write Community

Setting	Description	Default
V1, V2c Read/Write Community	Use a community string match for authentication, which means that the SNMP agent accesses all objects with read-only permissions using the community string public.	public (max. 30 characters)

For SNMP V3, there are two levels of privilege for different accounts to access the VPort. Admin privilege allows access and authorization to read and write MIB files. User privilege only assigns read-access of MIB files, but does not assign write-access.

Root Auth. Type (For SNMP V1, V2c, V3, and V3 only)

Setting	Description	Default
No-Auth	Use admin account to access objects. No authentication	No
MD5-Auth	Provide authentication based on the HMAC-MD5 algorithms. 8-character passwords are the minimum requirement for authentication.	No
SHA- Auth	Provide authentication based on the MAC-SHA algorithms. 8-character passwords are the minimum requirement for authentication.	No

Root Data Encryption Key (For SNMP V1, V2c, V3, and V3 only)

Setting	Description	Default
Enable	The data encryption key must be between 8 and 30 characters	No
Disable	No data encryption	No

User Auth. Type (For SNMP V1, V2c, V3, and V3 only)

Setting	Description	Default
No-Auth	Use admin or user account to access objects; authentication not required	No
MD5-Auth	Provides authentication based on the HMAC-MD5 algorithms; 8-character passwords are the minimum requirement for authentication.	No
SHA- Auth	Provides authentication based on the HMAC-SHA algorithms; 8-character passwords are the minimum requirement for authentication.	No

User Data Encryption Key (For SNMP V1, V2c, V3, and V3 only)

Setting	Description	Default
Enable	8-character data encryption key is the minimum requirement for data encryption. Maximum 30-character encryption key	No
Disable	No data encryption	No

Trap Settings

Setting	Description	Default
Trap Server IP/Name	Enter the IP address or name of the Trap Server used by your network.	No
Trap Community	Use a community string match for authentication; maximum of 30 characters.	No

Private MIB Information

The private SNMP Object ID of the VPort is the enterprise value: 8691.8.2.2. This number cannot be changed.

Modbus/TCP

Modbus is a serial communications protocol which is often used to connect a supervisory computer with a remote terminal unit (RTU) in supervisory control and data acquisition (SCADA) systems. To transmit Modbus over a TCP/IP network, a standard Modbus/TCP protocol is provided. With the support of the Modbus/TCP protocol, the SCADA/HMI system can directly communicate with the VPort to acquire its operational status.

ModBus/TCP

Modbus is a serial communications protocol for the industrial devices' communications with the SCADA/HMI system. With the Modbus/TCP protocol, the SCADA/ HMI system can directly communicate with VPort for acquiring the working status.

Enable ModBus/TCP

Save

Video Source

Video Source List

The screenshot shows the Moxa VPort D361 Video Decoder web interface. The top navigation bar includes the Moxa logo, the product name 'VPort D361 Video Decoder', and the website 'www.moxa.com'. Below this, a status bar displays system information: Model Name: VPort D361, Server Name: 1111, IP Address: 192.168.127.170, MAC Address: 00:90:22:88:99:02, Firm. Version: 1.0, Build: 10081716, and status indicators for STAT, PWR, and FAULT.

The main content area is titled 'Video Source List'. It features a 'Video Source Switch Mode' section with the following settings:

- Enable DI Change
- Auto Scan Interval: 5 sec (5-999)
- Alarm Trigger Interval: 3 sec (3-999)

Below these settings are buttons for 'Add to List', 'Search', 'Remove Select', and 'Modify'. A table lists the current video sources:

Idx	Description	Address	Camera/Stream	Type	Media	OSD	Alarm Trigger	Trans-PTZ	Audio Post
<input type="checkbox"/> 1		192.168.127.101	1/2	MJPEG	Video&Audio	Enable	Enable	Enable	Enable
<input type="checkbox"/> 2		192.168.127.101	1/1	H.264	Video&Audio	Enable	Enable	Enable	Enable

A maximum of 64 video sources can be added to the VPort D361's video source list. The Administrator can configure the video source operation settings on this page.

Video Source Switch Mode

Setting	Description	Default
Enable DI change	Enable the video source change via the DIs. DI 1 selects UP (from 1 to 2) DI 2 selects DOWN (from 2 to 1)	Disabled
Auto Scan	Enable the video source change by automatically scanning all the video sources in the list	Disabled
Interval	Time interval for switching the current video source to the next video source in auto scan mode	30 sec (10-999)
Alarm Trigger Interval	Time interval for doing the video source switch once the next alarm is triggered.	3 sec (3-999)

NOTE The Alarm Trigger Interval is used for the alarm buffer, and is used to prevent several alarms from being triggered at the same time. Otherwise, there could be a conflict in the operation of the video source switch. For this reason, you must set up a time interval between the 2 alarms. The alarms triggered during this time interval will be ignored.

The following description shows how to set up the video source list.

a. Add Video Source

Add Video Source

Idx:

Address:

Description:

Camera Idx:

Stream Idx:

HTTP Port:

Password:

Video Type: H.264 MJPEG

Protocol: Multicast UDP TCP HTTP Continuous Multicast Push

Media: Video & Audio Video Only Audio Only

OSD:

Alarm Trigger:

Transparent PTZ:

Audio Post:

Setting	Description	Default
Idx	The video source index for video source information and selection.	1 (1 to 64)
Address	The domain name or IP address of the video source	Blank (max. 64 bytes)
Description	Customized video source information to give users more information about the video source.	Blank (max. 40 bytes)
Camera Idx	Camera index of the video source. For example, if you are using 4-channel video encoders, the camera idx can help identify which channel is for the video source.	1
HTTP port	The port number of the video source	80
Password	The password of the Administrator's account used to access the video source	Blank (max. 14 bytes)
Video type	The video modulation to be decoded	Auto detect
Protocol (H.264)	The transmission protocol for H.264 video streams	TCP
Media	To select the decode mode as video & audio, video only, or audio only	Video & audio
OSD	To enable or disable the OSD (on-screen display) function	Enable
Alarm Trigger	To enable or disable the alarm trigger function, which is for immediately changing the video source to the alarm-triggered video source	Enable
Transparent PTZ	Enable or disable the transparent PTZ control function	disable
Audio post	Enable or disable the function for posting audio with video	disable

NOTE To enable the Alarm trigger function, the video source must be set up to send alarm messages via the sendalarm.cgi command. Please refer to the Appendix A, **How to Set Up the Alarm Trigger Function**.

b. Search

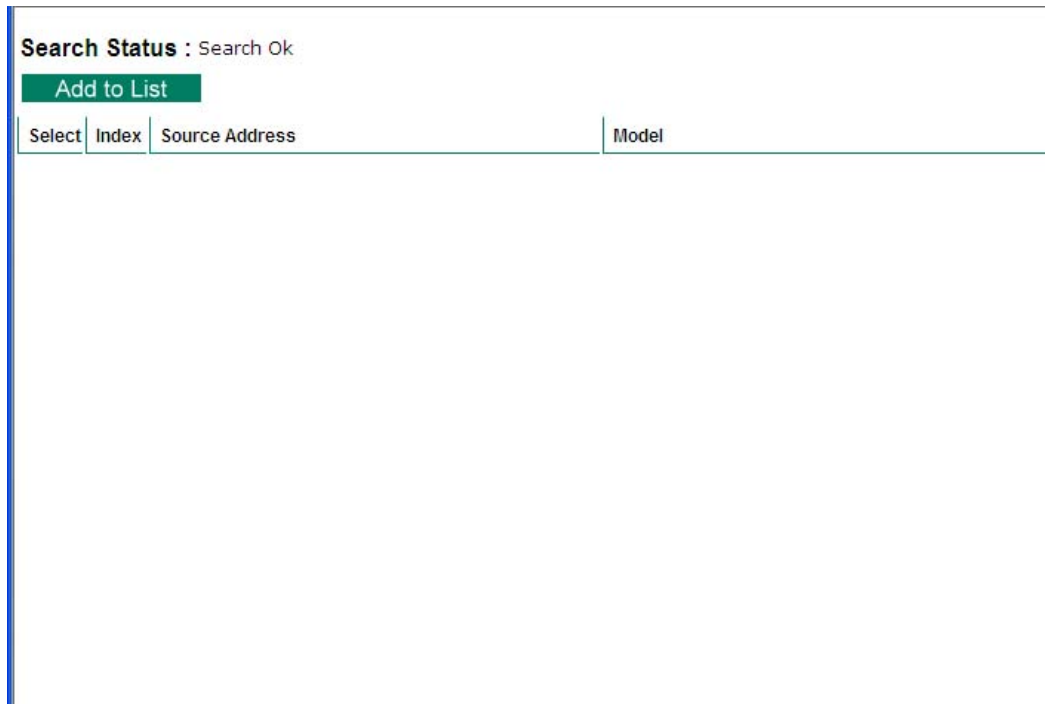

The **Search** function is used to search for video source devices on the network that are on the same domain network as the computer that you are searching from. After the search, the Administrator can select the video source device and then click **Add to List** to add this video source to the video source list. After that, the Administrator can use the **Modify** function to edit the video source configurations.

c. Remove Select

This button is for deleting the video source being selected (check the check box).

d. Modify

This button can edit the configurations of the selected video source.

Video Source Log

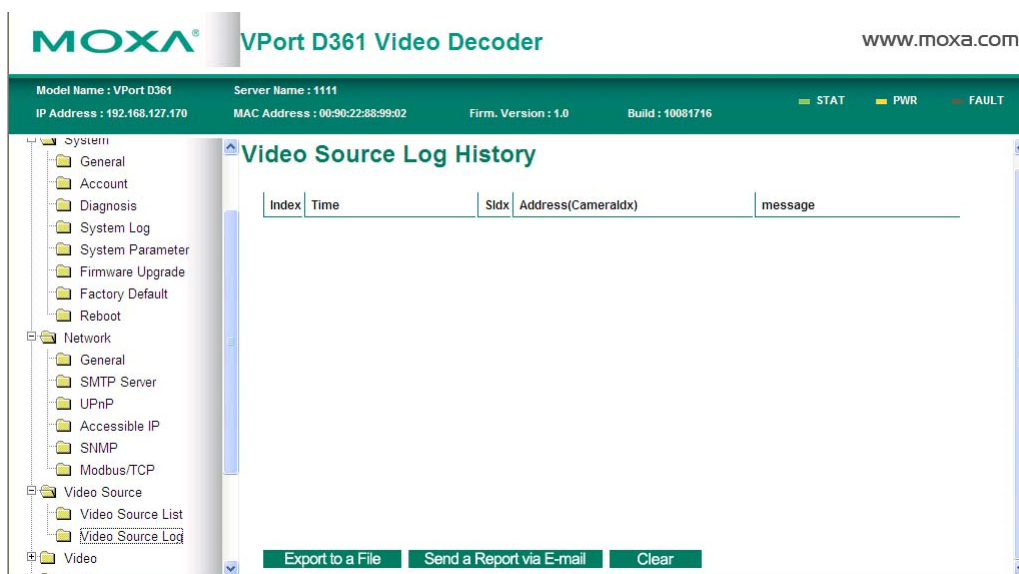

The **Video Source Log** shows the history of the video source alarm trigger, which can be a good reference for the Administrator. A maximum of 1000 records can be listed. In addition, the Administrator can also export the log history to a file, or send it by email.

Video

OSD Settings

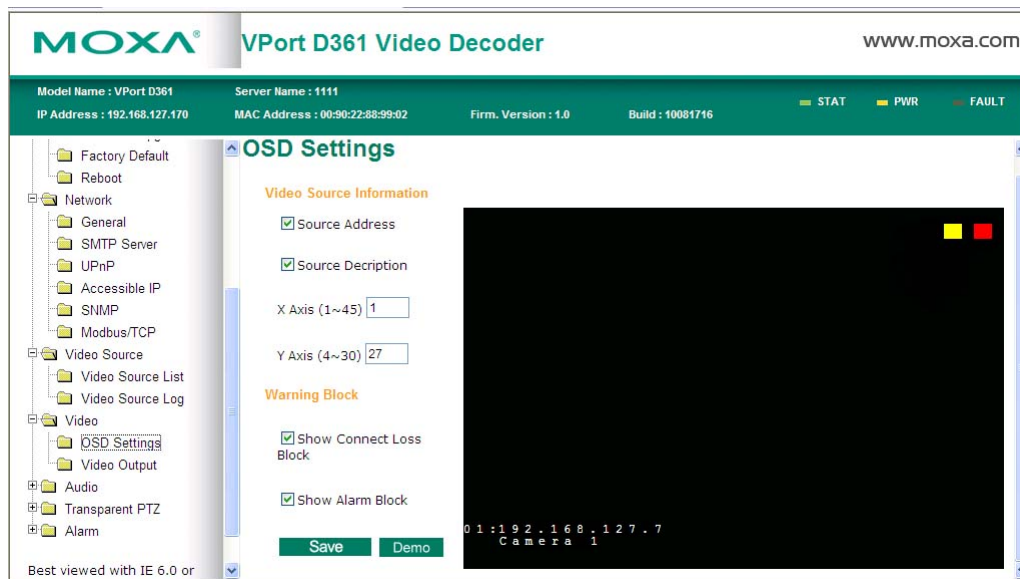

On this page, the Administrator can customize the OSD (on-screen display) information and location of the video image. Two color blocks are located in the top-right corner of the video image.

- a. Connect loss block:** The connect loss block is shown in yellow to indicate the status of the video source.
 - Stable yellow: video source is connected.
 - Blinking yellow: the video source is disconnected or has trouble sending video streams.
- b. Alarm block:** The alarm block is shown in red to indicate the status of the alarm being triggered from the video source site.
 - Stable red: no alarm is detected.
 - Blinking red: an alarm is being triggered.

In addition to these 2 color blocks, 2 additional pieces of video source information can be shown on the video image.

- a. Source Address:** The domain name or IP address of the video source
- b. Source Description:** The customized information of the video source

Both pieces of information can be set up to be located on the video images by setting the locations of the **X Axis** and **Y Axis**.

Setting	Description	Default
Source Address	Enable or disable the source address being displayed on the video image	enable
Source Description	Enable or disable the source description being displayed on the video image	enable
X Axis	Set up the X axis of the video source information display location	3 (1-45)
Y Axis	Set up the Y axis of the video source information display location	27 (4-30)
Show Connect Loss block	Enable or disable the display of the connect loss block	enable
Show Alarm block	Enable or disable the display of the alarm block	enable

NOTE The OSD (on-screen display) can be used to give users the video source status and information from the analog video display. The Administrator should set up the location of the video source information properly for easy viewing.

Video Output

The VPort supports both NTSC and PAL video output. The Administrator can manually select **NTSC** or **PAL** video signals.

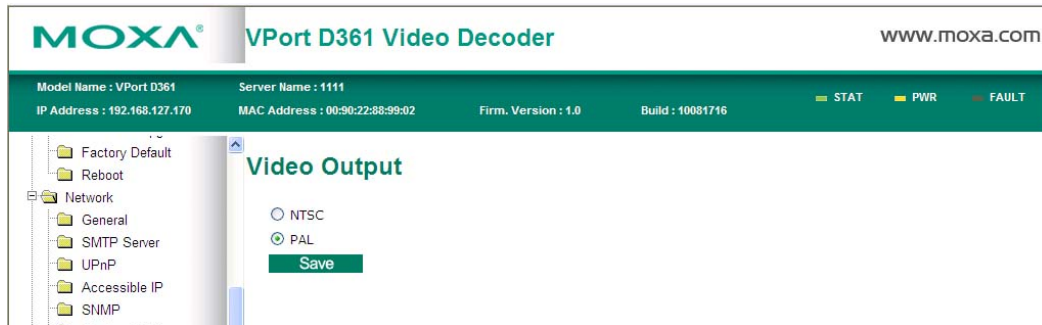

NOTE The video frame rate, video quality, and video resolution of the VPort D361 outputs are determined by the configurations of the video streams being generated by the video source.

Audio

Audio Settings

The VPort D361 can decode the audio being generated from the video source and can also send the audio to the video source, allowing users to enable voice communication between the video source and the VPort D361.

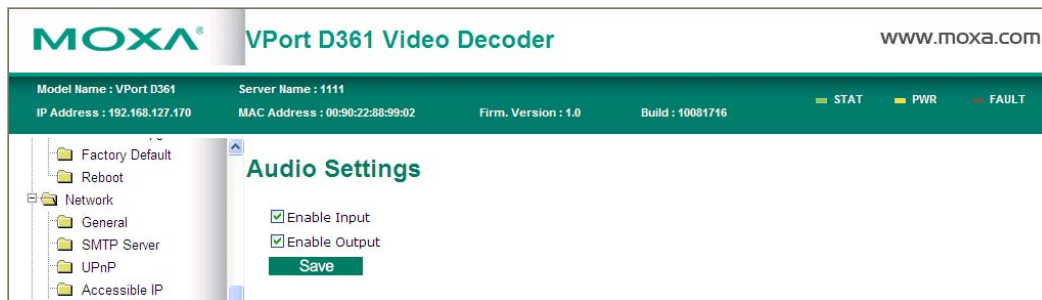

Setting	Description	Default
Enable input	Enable or disable the audio input	Enable
Enable output	Enable or disable the audio output	Enable

Transparent PTZ

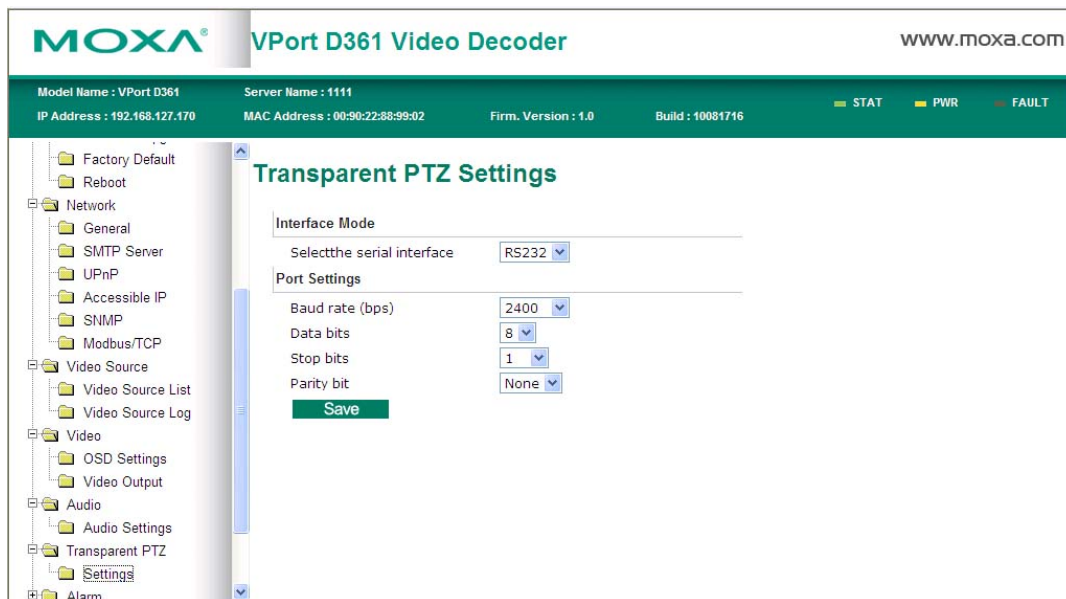

The VPort D361 supports the transparent PTZ control function, which means the user can connect a legacy PTZ control panel to the VPort D361's PTZ port to control the PTZ camera connected to the VPort video encoder. It is not necessary to install PTZs.

NOTE To enable the transparent PTZ control function, the PTZ driver in the VPort series video encoders should be set to Transparent PTZ Control.

Interface Mode

Setting	Description	Default
Selecting serial interface	Select the serial interface as RS-232 or RS-485TX/ RS-422	RS-485TX/ RS-422

Port Settings

Setting	Description	Default
Baud Rate (bps)	the baud rate setting of the PTZ port	2400
Data bits	the data bits of the PTZ port	8
Stop bits	the stop bits of the PTZ port	1
Parity bit	the parity bit of the PTZ port	None

Alarm

Relay Settings

This relay settings section allows the Administrator to restore the status of the relay outputs to the default settings.

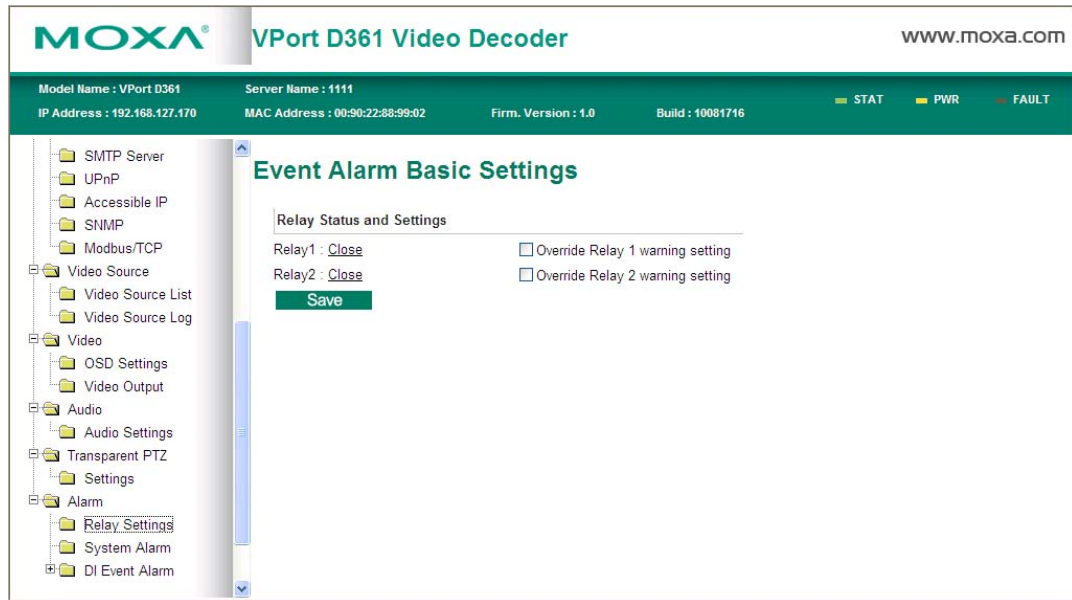

NOTE The relays will not be triggered when the Override Relay 1 warning setting and Override Relay 2 warning setting boxes are checked. Un-check these 2 boxes to allow the relays to be triggered.

System Alarm

In addition to the LED indicators, two kinds of system alarm are provided by the VPort D361 for notifying the Administrator.

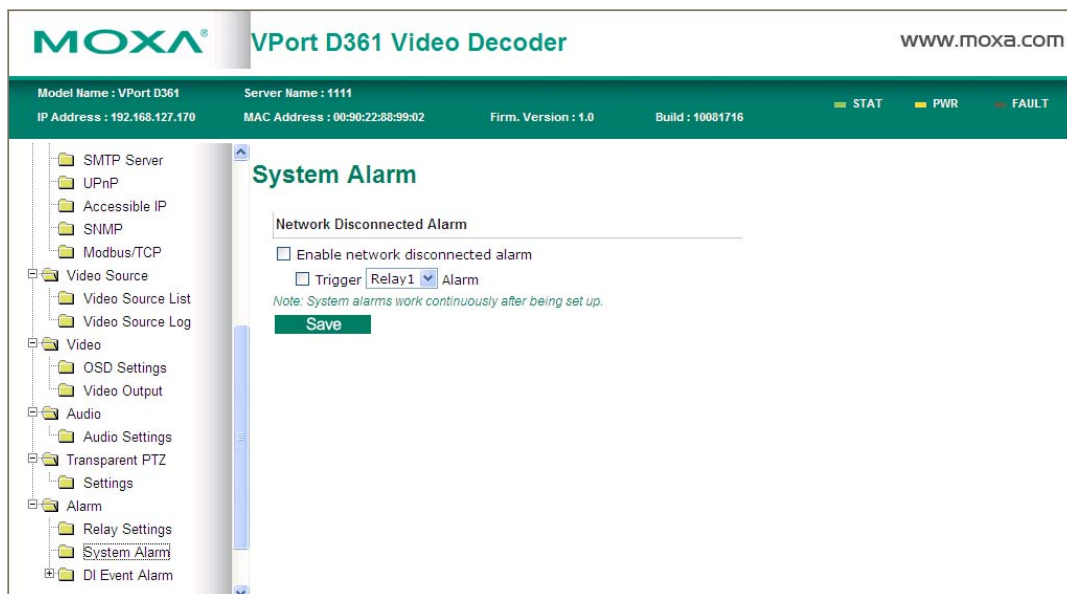

Network Disconnected Alarm

Setting	Description	Default
Enable network disconnected alarm	Enable or disable network disconnected alarm.	Disabled
Trigger Relay alarm	Enable or disable the action in triggering Relay 1 or Relay 2 alarms.	Disabled

NOTE Since several alarms can be set up to trigger the VPort’s relays, the Administrator should configure these alarms carefully in case a relay message is read incorrectly.

DI Event Alarm

Basic

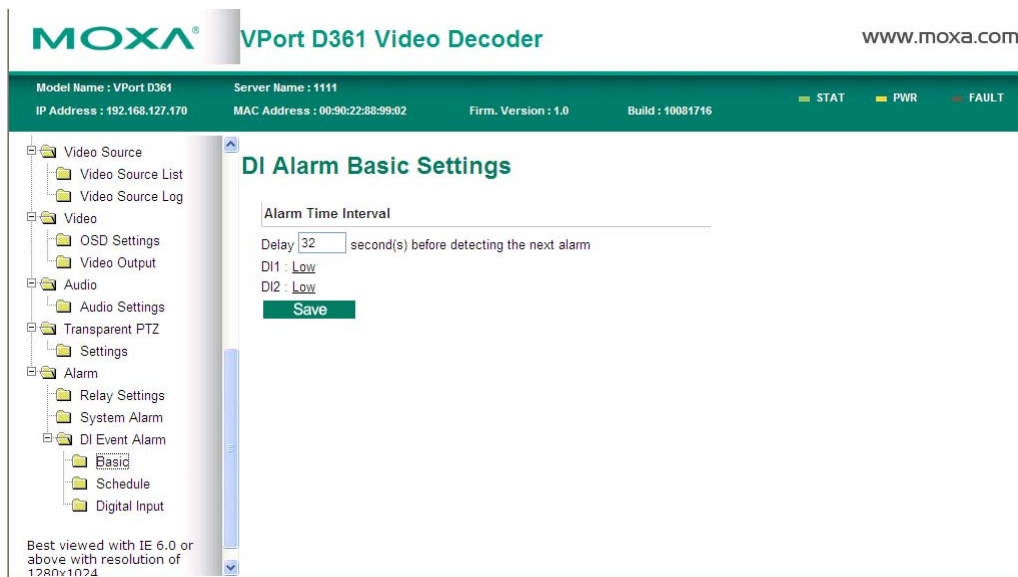

Alarm Time Interval

Setting	Description	Default
Delay second(s) before detecting the next alarm	Set up the time interval for each event alarm triggered.	32 seconds (1 to 999 seconds)

DI Status

The Administrator can check the current DI status here.

Schedule

A schedule is provided to set event alarms for daily security applications.

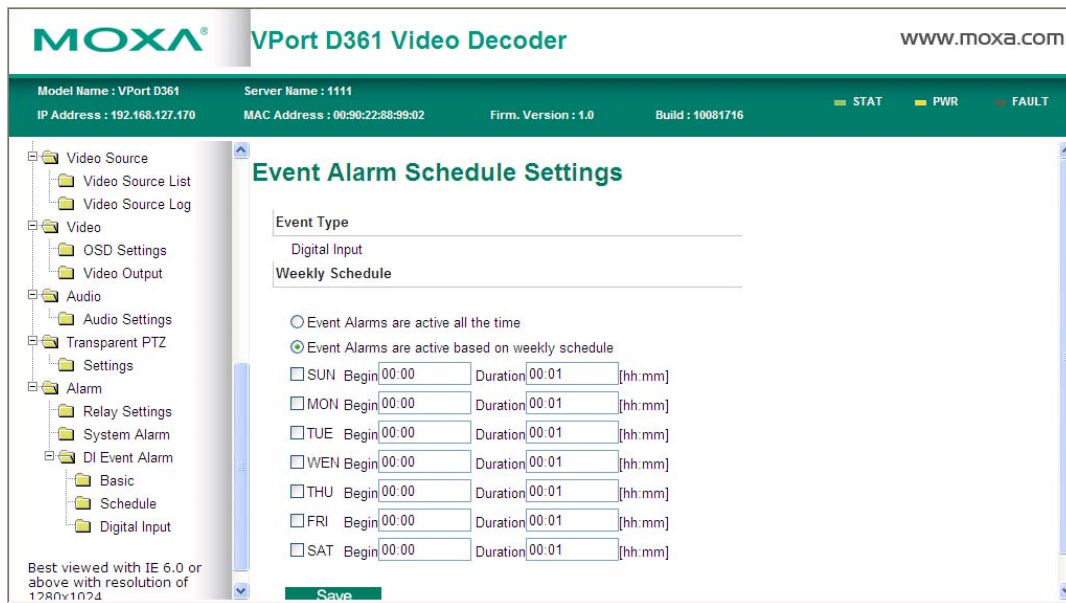

Weekly Schedule

Setting	Description	Default
Event Alarms are active all the time	Select the option "Event Alarms are active all the time"	Event Alarms are active all the time
Event Alarms are on a weekly schedule	Select to operate event alarms on a weekly schedule.	

NOTE Either **Event Alarms are active all the time** or **Event Alarms are active based on weekly schedule** must be selected, or the applications described in the following sections will not work properly.

Setting	Description	Default
<input type="checkbox"/> Sun <input type="checkbox"/> Mon <input type="checkbox"/> Tue <input type="checkbox"/> Wed <input type="checkbox"/> Thu <input type="checkbox"/> Fri <input type="checkbox"/> Sat	Select the days of the week for the event alarms' schedule.	None
Begin 00:00	Set the beginning time of event alarm.	00:00
Duration 00:00	Setup the time period of event alarm being activated.	00:00

Digital Input

Two digital inputs are provided by the VPort D361 for linking with alarm detection devices, such as sensors.

Setting	Description	Default
Enable digit input alarm	Enable or disable the digit input alarm.	Disable

Trigger Conditions

Setting	Description	Default
High	The DI is always in the "High" state after an alarm is detected.	Disabled
Low	The DI is always in the "Low" state after an alarm is detected.	Enabled
Rising	The DI goes from state "Low" to state "High" and then back to state "Low" when an alarm is detected.	Disabled
Falling	The DI goes from state "High" to state "Low" and then back to state "High" when an alarm is detected.	Disabled

NOTE DI specifications are given in Chapter 1.

Trigger Actions

The Administrator can set up trigger actions for each DI, including Trigger Relay1 alarm, Trigger Relay2 alarm, Send warning message via E-mail.

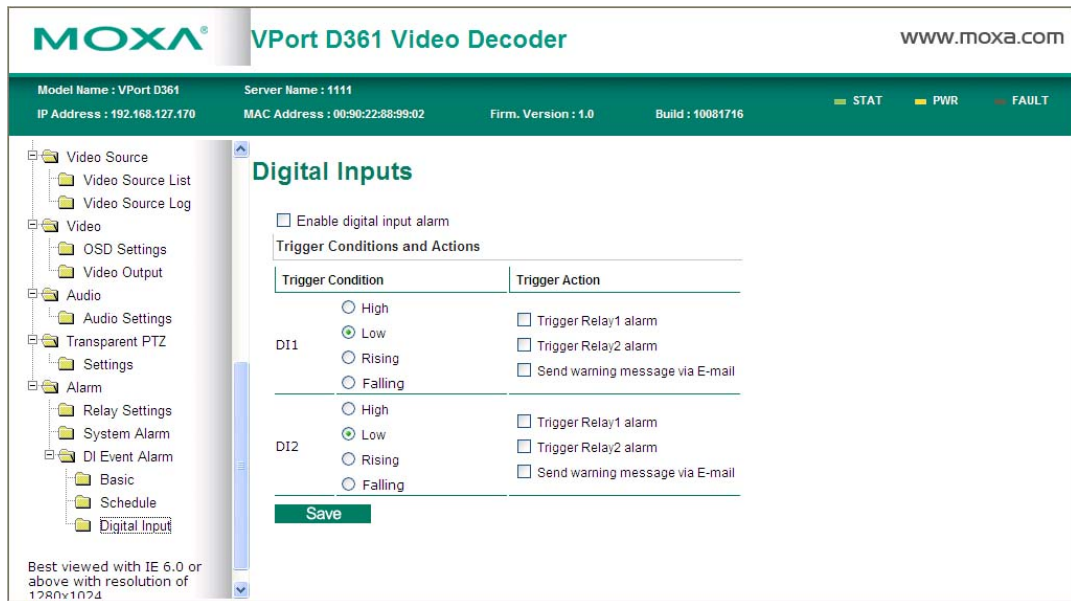

A

How to Set Up the Alarm Trigger Function

The VPort D361 supports an alarm trigger function that allows the video source to be switched to a video source, based on an alarm trigger condition. For this function to work, the video source must be set up to send alarm messages to the VPort D361 with the `sendalarm.cgi` command. Users can implement the `sendalarm.cgi` command with the HTTP Event function supported by the VPort series products, or customized software.

HTTP Event Function

The following example uses the VPort 461.

Step 1: Set up the HTTP Event Server.

HTTP Event Servers

VPort can send the customized alarm actions and messages to the HTTP Event Server capability for the users designing the customized alarm system.

Hostname	<input type="text"/>
Server 1	<input type="text"/>
User name:	<input type="text"/>
Password:	<input type="text"/>
Server 2	<input type="text"/>
User name:	<input type="text"/>
Password:	<input type="text"/>
Server 3	<input type="text"/>
User name:	<input type="text"/>
Password:	<input type="text"/>
Server 4	<input type="text"/>
User name:	<input type="text"/>
Password:	<input type="text"/>
<input type="button" value="Save"/>	

Hostname

If the VPort D361 uses a domain name instead of an IP address, then type the domain name in the **Hostname** input box. If a domain name is not being used, then leave the Hostname field blank.

Server 1, 2, 3, 4

Input the `sendalarm.cgi` command, video source's user name, and password.

The `sendalarm.cgi` command should have the form `http://IP address or domain name/moxa-cgi/sendalarm.cgi`.

Step 2: Set up the alarm to **Send message via HTTP Event Servers**.

Digital Inputs

Enable digital input alarm

Trigger Conditions and Actions

Trigger Condition	Trigger Action	HTTP Action Setting
DI1	<input type="radio"/> High	<input type="checkbox"/> Trigger Relay1 alarm
	<input type="radio"/> Low	<input type="checkbox"/> Trigger Relay2 alarm
	<input checked="" type="radio"/> Rising	<input type="checkbox"/> Send snapshot image via E-mail
	<input type="radio"/> Falling	<input checked="" type="checkbox"/> Send snapshot image via FTP
		<input type="checkbox"/> Send message via HTTP Event Servers
DI2	<input type="radio"/> High	<input type="checkbox"/> Trigger Relay1 alarm
	<input type="radio"/> Low	<input type="checkbox"/> Trigger Relay2 alarm
	<input checked="" type="radio"/> Rising	<input type="checkbox"/> Send snapshot image via E-mail
	<input type="radio"/> Falling	<input checked="" type="checkbox"/> Send snapshot image via FTP
		<input type="checkbox"/> Send message via HTTP Event Servers

Note: HTTP Action Setting allows the VPort sending the customized alarm messages to the HTTP Event Server when the event is triggered. Please refer to URL syntax being defined in RFC 1738 and the customer-defined commands for writing this setting with 100 characters.

Save

Enable the Alarm Condition

The VPort 461 supports video motion detection, digital input, and video loss alarm conditions.

Trigger Condition

Select the condition for triggering the alarm.

Trigger Action

Choose **Send message via HTTP Event Servers** for sending the alarm message to the VPort D361.

HTTP Action Settings

In this section, select Server 1, 2, 3, or 4 for the target HTTP Event Server, and then input the alarm message being sent. Two messages should be listed.

- Cameraidx=xxxx** or **Idx=xxxx** is for identifying the video source.
 - Cameraidx is the camera channel number of the video source. Since the VPort 351 is a 1-channel video encoder, **Cameraidx = 1**.
 - Idx is the channel index of this video source in the VPort D361's video source list. For example, if this VPort 461 is indexed in number 5 of the VPort D361's video source list, then **Idx = 5**.
- Message=xxxx** is for the description of this alarm. Users can customize some information to describe this alarm. For example, if the DI1 alarm is triggered in low status, the user can use **Message=DI1Low** to get the **DI1Low** information from the video source log.

Customized software

Users also can program customized software to send the alarm message to the VPort D361 for the alarm trigger function. Users will need to program the sendalarm.cgi command into the software.

Syntax:

http://<server>/moxa-cgi/sendalarm.cgi?address=xxxx&cameraidx=xxxx&message=xxxx

Example:

<http://192.168.127.100/moxa-cgi/sendalarm.cgi>

address=192.168.127.100&cameraidx=1&message=DI1low

B

Modus Address Table

Address	Unit (4 Bytes)	Item name	
0x0000	1	Vender ID	0x1393
0x0001	1	Unit ID	0x01
0x0002	1	Product Code	0x8802
0x0010	20	Vender Name	moxa
0x0030	20	Product Name	VPortD361
0x0050	1	Serial Number	
0x0051	2	Firmware Version	
0x0053	2	Release Date	
0x0055	2	MAC Address	
0x005A	1	Fault Led Status	
0x0080	1	DI 1 Status	
0x0081	1	DI 2 Status	
0x0084	1	DO 1 Status	
0x0085	1	DO 2 Status	

C

Time Zone Table

The hour offsets for different time zones are shown below. You will need this information when setting the time zone in automatic date/time synchronization. GMT stands for Greenwich Mean Time, which is the global time that all time zones are measured from.

(GMT-11:00)	Midway Island, Samoa
(GMT-10:00)	Hawaii
(GMT-09:00)	Alaska
(GMT-08:00)	Pacific Time (US & Canada), Tijuana
(GMT-07:00)	Arizona
(GMT-07:00)	Chihuahua, La Paz, Mazatlan
(GMT-07:00)	Mountain Time (US & Canada)
(GMT-06:00)	Central America
(GMT-06:00)	Central Time (US & Canada)
(GMT-06:00)	Guadalajara, Mexico City, Monterrey
(GMT-06:00)	Saskatchewan
(GMT-05:00)	Bogota, Lima, Quito
(GMT-05:00)	Eastern Time (US & Canada)
(GMT-05:00)	Indiana (East)
(GMT-04:00)	Atlantic Time (Canada)
(GMT-04:00)	Caracas, La Paz
(GMT-04:00)	Santiago
(GMT-03:30)	Newfoundland
(GMT-03:00)	Brasilia
(GMT-03:00)	Buenos Aires, Georgetown
(GMT-03:00)	Greenland
(GMT-02:00)	Mid-Atlantic
(GMT-01:00)	Azores
(GMT-01:00)	Cape Verde Is.
(GMT)	Casablanca, Monrovia
(GMT)	Greenwich Mean Time: Dublin, Edinburgh, Lisbon, London
(GMT+01:00)	Amsterdam, Berlin, Bern, Stockholm, Vienna
(GMT+01:00)	Belgrade, Bratislava, Budapest, Ljubljana, Prague
(GMT+01:00)	Brussels, Copenhagen, Madrid, Paris
(GMT+01:00)	Sarajevo, Skopje, Warsaw, Zagreb
(GMT+01:00)	West Central Africa
(GMT+02:00)	Athens, Istanbul, Minsk
(GMT+02:00)	Bucharest
(GMT+02:00)	Cairo
(GMT+02:00)	Harare, Pretoria
(GMT+02:00)	Helsinki, Kyiv, Riga, Sofia, Tallinn, Vilnius
(GMT+02:00)	Jerusalem
(GMT+03:00)	Baghdad
(GMT+03:00)	Kuwait, Riyadh
(GMT+03:00)	Moscow, St. Petersburg, Volgograd
(GMT+03:00)	Nairobi

(GMT+03:30) Tehran
(GMT+04:00) Abu Dhabi, Muscat
(GMT+04:00) Baku, Tbilisi, Yerevan
(GMT+04:30) Kabul
(GMT+05:00) Ekaterinburg
(GMT+05:00) Islamabad, Karachi, Tashkent
(GMT+05:30) Chennai, Kolkata, Mumbai, New Delhi
(GMT+05:45) Kathmandu
(GMT+06:00) Almaty, Novosibirsk
(GMT+06:00) Astana, Dhaka
(GMT+06:00) Sri Jayawardenepura
(GMT+06:30) Rangoon
(GMT+07:00) Bangkok, Hanoi, Jakarta
(GMT+07:00) Krasnoyarsk
(GMT+08:00) Beijing, Chongqing, Hongkong, Urumqi
(GMT+08:00) Taipei
(GMT+08:00) Irkutsk, Ulaan Bataar
(GMT+08:00) Kuala Lumpur, Singapore
(GMT+08:00) Perth
(GMT+09:00) Osaka, Sapporo, Tokyo
(GMT+09:00) Seoul
(GMT+09:00) Yakutsk
(GMT+09:30) Adelaide
(GMT+09:30) Darwin
(GMT+10:00) Brisbane
(GMT+10:00) Canberra, Melbourne, Sydney
(GMT+10:00) Guam, Port Moresby
(GMT+10:00) Hobart
(GMT+10:00) Vladivostok
(GMT+11:00) Magadan, Solomon Is., New Caledonia
(GMT+12:00) Auckland, Wellington
(GMT+12:00) Fiji, Kamchatka, Marshall Is..
(GMT+13:00) Nuku'alofa

Technical Specifications

Video	
Video Decoding	H.264, MJPEG (Auto detecting) video stream
Video Input	Video streams from the VPort series Video Encoder or IP Camera via TCP/IP network
Video Output	1 BNC connector, NTSC, or PAL
Resolution	Max. 540 TVL Lines
Video Source	Max. 64, manually selected (by web server or digital inputs) or automatic scan with time interval
Video Viewing	<ul style="list-style-type: none"> • Max. 30/25 FPS (NTSC/PAL) being decoded • OSD (on-screen display) with video source, encoder IP, date/time, and customized information
Audio	
Audio Input	1 Line-in or MIC-in, 3.5 mm phone jack
Audio Output	1 Line-out, 3.5 mm phone jack
Audio encoding	PCM
Audio decoding	Mono
Network	
Protocols	TCP, UDP, HTTP, SMTP, Telnet, NTP, DNS, DHCP, UPnP, RTP, RTSP, SNMPv3
Ethernet	1 10/100BaseT(X) auto negotiation speed RJ45 port
Serial Port	
PTZ port	1, RS-232 or RS-422/485 Terminal Block connector, Max. 115.2 Kbps
Console port	1 RS-232 RJ45 port
GPIO	
Digital Input	2, max. 8 mA per input "Low": +13V to +30V "High": -30V to +3V
Relay Output	2 (max. 24 VDC @ 1A)
LED Indicators	
PWR	Power
FAULT	Can be set up to correspond to system alarm, or network down
STAT	System boots properly or not
Power	
Input	1 12/24 VDC or 24 VAC input
Consumption	Approximately 6 W
Physical Propertires	

Casing	IP30 protection, metal case
Dimensions (W x D x H)	52.98 x 135 x 105 mm (2.09 x 5.31 x 4.13 in.)
Weight	890 g
Installation	DIN-Rail or wall mounting (with optional WK-46 kit)

Environmental Limits

Operating Temperature	0 to 60°C (32 to 140°F) -40 to 75°C (-40 to 167°F) for -T model
Storage Temperature	-40 to 85°C (-40 to 185°F)
Ambient Relative Humidity	5 to 95% (non-condensing)

Regulatory Approvals

Safety	UL 508 (Pending)
EMI	FCC Part 15, CISPR (EN55022) class A EN61000-4-2 (ESD), Level 3
EMS	EN61000-4-3 (RS), Level 3 EN61000-4-4 (EFT), Level 3 EN61000-4-5 (Surge), Level 3 EN61000-4-6 (CS), Level 3 EN61000-4-8, EN61000-4-11
Shock	IEC60068-2-27
Freefall	IEC60068-2-32
Vibration	IEC60068-2-6
MTBF	370,000 hours
WARRANTY	5 years

Alarm Features

- Automatically switch to the video source once an event is triggered at video source site
- Daily repeat timing schedule for DI sensors
- JPEG snapshots for pre/trigger/post alarm images

Automatic transfer of stored images by email with event-triggered actions

Security

- The Administrator's password protection
- Accessible IP address filtering