



▶ Linear & Rotary Positioning Stages



▶ Servo Motors & Drives



▶ Gearmotors & Gearheads



GM Series
Stealth Planetary
Gearmotor Product Manual





GM Series Stealth Planetary Gearmotor

Product Manual

Rev: 7.0 / 0305
P/N: 12197002

Please check www.baysidemotion.com for latest revisions.

Product Manual

GM Series

Gearmotor Manual

Table Of Contents

I. Introduction	1
II. Packaging	2
III. Electrical Specification	3
Motor	
Encoder	
Resolver	
Brake	
IV. Wiring	12
V. Mechanical Specifications	14
VI. Maintenance & Lubrication	16



I. Introduction

Thank you for purchasing the GM Series, Servo Gearmotor. The GM Series gearmotor is a combination of a brushless dc servo motor and a helical planetary gearhead. This unique design provides a single piece construction of the rotor assembly and input gear, eliminating any mechanical joining between a motor shaft and input gear. This increases reliability, and provides smoother and quieter performance in a smaller footprint than mechanically coupled devices.

This manual provides installation and maintenance information for the:

GM60 Series

GM90 Series

GM115 Series

If there are any questions regarding the installation of your product, please contact Bayside Motion Group, Technical Services at (516)484-5482 for additional support.

II. Packaging

Standard Gearmotors are wrapped in plastic and packaged in a cardboard box, with environmentally safe, foam-in-place padding. The cardboard box may be recycled and the packing material can be disposed of normally. In some cases, quantity shipments may be provided in wooden crates.

Standard Gearmotors will arrive with a key pressed into the output shaft. If the key must be removed, do not apply shock loading to the output shaft. The gearmotor can also be ordered without the key.

Your Gearmotor is prefilled with an oil lubricant. The lubricant type and maintenance requirements are defined in Section VI. Maintenance and Lubrication. Removal and reinstallation of oil should be done through the fittings provided in the front flange.

III. Electrical Specifications

Motor

Standard Gearmotors are provided with a single or double stack motor winding, for 160 vdc or 300 Vdc operation. To identify the specific winding please refer to the following model number definition.

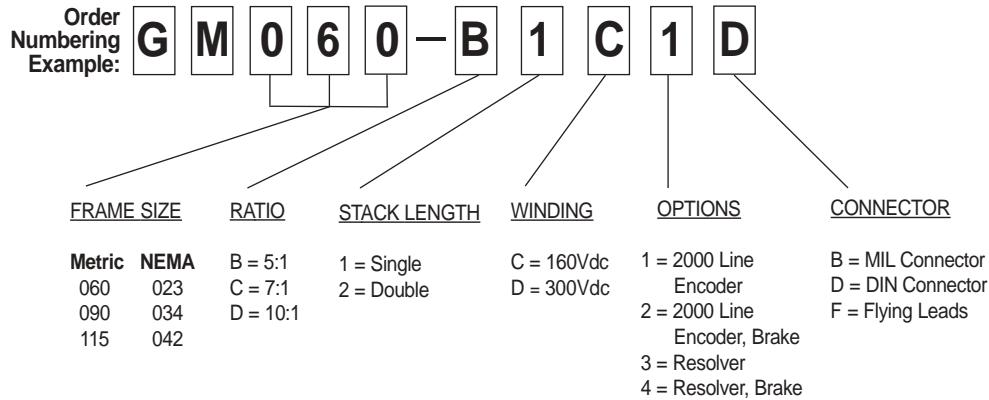

Gearmotors are supported by a worldwide network of offices and local distributors. Call 1-800-305-4555 for application engineering assistance or for the name of your local distributor. Information can also be obtained at www.baysidemotion.com.

Motor Specifications

Performance Specifications

Mechanical Specifications

Frame Size	Stack Length	Weight without Brake		Maximum Radial Load		Torsional Stiffness		Standard Backlash (arc min)	Low Backlash (arc min)
		(kg)	(lb)	(N)	(lb)	(Nm/arc min)	(in lb/arc min)		
GM060	Single	2.1	4.7	1300	292	6	53	15	10
GM060	Double	2.8	6.2	1300	292	6	53	15	10

Single Stack Specifications

Frame Size	Ratio	Max. Speed ⁽¹⁾ (RPM)	Cont. Stall Torque ⁽¹⁾ T _C		Peak Torque ⁽¹⁾ T _P		Winding C:160 Vdc D:300 Vdc	Voltage Constant ⁽¹⁾ K _E (V/kRPM)	Torque Constant ⁽¹⁾ K _T		Induct L (mH)	Cold Resistance R (ohms)	Cont. Current I _C (amps)	Peak Current I _P (amps)	Inertia	
			(Nm)	(in lb)	(Nm)	(in lb)			(Nm/amp)	(in lb/amp)					(gm cm sec ²)	(lb in sec ²)
GM060	5:1	1,100	3.1	27.5	9.3	82.5	C	146.5	1.40	12.5	12.5	11.8	2	7	0.23	0.00019
GM060	5:1	1,000	3.1	27.5	9.3	82.5	D	296.5	2.85	25.0	51.2	48.3	1	3	0.23	0.00019
GM060	7:1	780	4.3	38.5	13.0	115.5	C	205.1	1.96	17.5	12.5	11.8	2	7	0.19	0.00016
GM060	7:1	720	4.3	38.5	13.0	115.5	D	415.1	3.99	35.0	51.2	48.3	1	3	0.19	0.00016
GM060	10:1	540	6.2	55.0	18.6	165.0	C	293.0	2.80	25.0	12.5	11.8	2	7	0.19	0.00016
GM060	10:1	500	6.2	55.0	18.6	165.0	D	593.0	5.70	50.0	51.2	48.3	1	3	0.19	0.00016

Double Stack Specifications

Frame Size	Ratio	Max. Speed ⁽¹⁾ (RPM)	Cont. Stall Torque ⁽¹⁾ T _C		Peak Torque ⁽¹⁾ T _P		Winding C:160 Vdc D:300 Vdc	Voltage Constant ⁽¹⁾ K _E (V/kRPM)	Torque Constant ⁽¹⁾ K _T		Induct L (mH)	Cold Resistance R (ohms)	Cont. Current I _C (amps)	Peak Current I _P (amps)	Inertia	
			(Nm)	(in lb)	(Nm)	(in lb)			(Nm/amp)	(in lb/amp)					(gm cm sec ²)	(lb in sec ²)
GM060	5:1	1100	5.1	45.0	15.2	135.0	C	146.5	1.40	12.5	6.2	4.8	4	11	0.29	0.00025
GM060	5:1	1000	5.1	45.0	15.2	135.0	D	293.0	2.80	25.0	25	19	2	5	0.29	0.00025
GM060	7:1	780	7.1	63.0	21.3	189.0	C	205.6	1.96	17.5	6.2	4.8	4	11	0.25	0.00022
GM060	7:1	720	7.1	63.0	21.3	189.0	D	410.2	3.92	35.0	25	19	2	5	0.25	0.00022
GM060	10:1	540	10.1	90.0	30.4	270.0	C	293.0	2.80	25.0	6.2	4.8	4	11	0.25	0.00022
GM060	10:1	500	10.1	90.0	30.4	270.0	D	586.0	5.60	50.0	25	19	2	5	0.25	0.00022

Note: Pole Count for GM060 is 6

Thermal Resistance for GM060 is 1.5 °C/W

Stator winding thermal resistance (winding to ambient) is for the unit, mounted to a 254mm x 254mm x 12.7mm (10in x 10in x 0.5in) aluminum plate.

(1) These specifications refer to the output of the GM assembly.

When programming a digital amplifier for use with a GM assembly, these specifications must be adjusted by the ratio to create actual motor performance

Specification are subject to change without notice

Single Stack - 160 volt

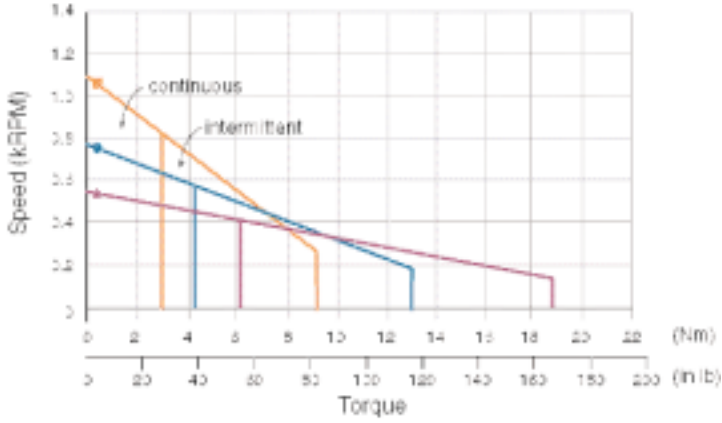

Single Stack - 300 volt

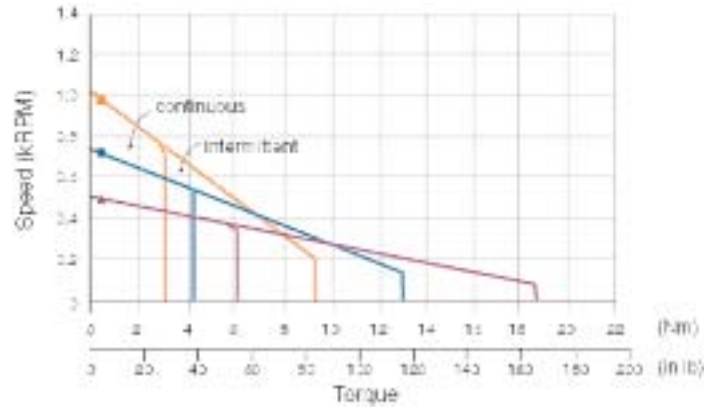

5:1  7:1  10:1 

Double Stack - 160 volt

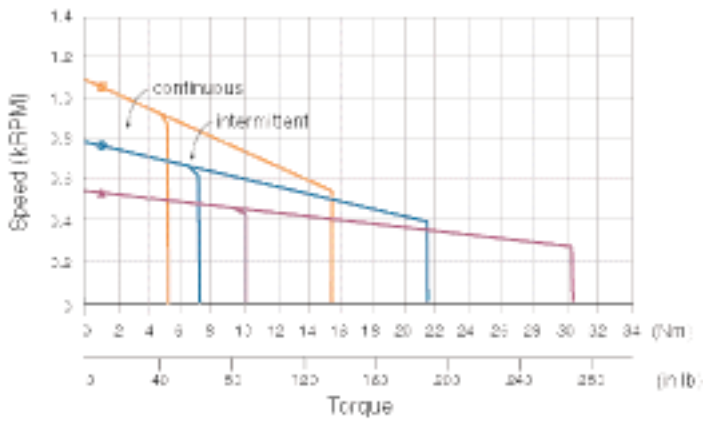

Double Stack - 300 volt

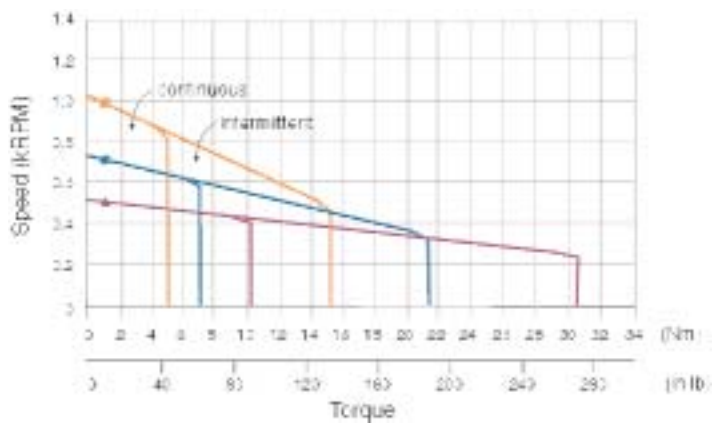

Performance Specifications

Mechanical Specifications

Frame Size	Stack Length	Weight without Brake		Maximum Radial Load		Torsional Stiffness		Standard Backlash (arc min)	Low Backlash (arc min)
		(kg)	(lb)	(N)	(lb)	(Nm/arc min)	(in lb/arc min)		
GM090	Single	6.0	13.2	2600	584	11	87	15	10
GM090	Double	7.4	16.3	2600	584	11	87	15	10

Single Stack Specifications

Frame Size	Ratio	Max. Speed ⁽¹⁾ (RPM)	Cont. Stall Torque ⁽¹⁾ T _C		Peak Torque ⁽¹⁾ T _P		Winding C:160 Vdc D:300 Vdc	Voltage Constant ⁽¹⁾ K _E (V/kRPM)	Torque Constant ⁽¹⁾ K _T		Induct L (mH)	Cold Resistance R (ohms)	Cont. Current I _C (amps)	Peak Current I _P (amps)	Inertia	
			(Nm)	(in lb)	(Nm)	(in lb)			(Nm/amp)	(in lb/amp)					(gm cm sec ²)	(lb in sec ²)
GM090	5:1	900	8.7	77.0	26.0	231.0	C	170.5	1.65	14.5	4.5	2.5	5	16	1.16	0.00100
GM090	5:1	870	8.7	77.0	26.0	231.0	D	341.0	3.25	29.0	18.1	10.1	3	8	1.16	0.00100
GM090	7:1	670	12.0	107.0	36.1	321.0	C	238.7	2.31	20.3	4.5	2.5	5	16	0.94	0.00081
GM090	7:1	620	12.0	107.0	36.1	321.0	D	477.9	4.55	40.6	18.1	10.1	3	8	0.94	0.00081
GM090	10:1	450	17.2	153.0	51.7	459.0	C	341.0	3.30	29.0	4.5	2.5	5	16	0.94	0.00081
GM090	10:1	430	17.2	153.0	51.7	459.0	D	682.0	6.50	58.0	18.1	10.1	3	8	0.94	0.00081

Double Stack Specifications

Frame Size	Ratio	Max. Speed ⁽¹⁾ (RPM)	Cont. Stall Torque ⁽¹⁾ T _C		Peak Torque ⁽¹⁾ T _P		Winding C:160 Vdc D:300 Vdc	Voltage Constant ⁽¹⁾ K _E (V/kRPM)	Torque Constant ⁽¹⁾ K _T		Induct L (mH)	Cold Resistance R (ohms)	Cont. Current I _C (amps)	Peak Current I _P (amps)	Inertia	
			(Nm)	(in lb)	(Nm)	(in lb)			(Nm/amp)	(in lb/amp)					(gm cm sec ²)	(lb in sec ²)
GM090	5:1	720	14.0	124.0	41.9	372.0	C	221.5	2.10	18.5	3.8	1.6	8	7	20	0.00113
GM090	5:1	700	14.0	124.0	41.9	372.0	D	426.0	4.05	36.0	14.1	6.3	8	3	10	0.00113
GM090	7:1	500	19.5	173.0	58.4	519.0	C	310.1	2.94	25.9	3.8	1.6	8	7	20	0.00094
GM090	7:1	500	19.5	173.0	58.4	519.0	D	596.4	5.67	50.4	14.1	6.3	8	3	10	0.00094
GM090	10:1	360	27.8	247.0	83.4	741.0	C	443.0	4.20	37.0	3.8	1.6	8	7	20	0.00094
GM090	10:1	350	27.8	247.0	83.4	741.0	D	852.0	8.10	72.0	14.1	6.3	8	3	10	0.00094

Note: Pole Count for GM090 is 8

Thermal Resistance for GM090 is 1.2 °C/W

Stator winding thermal resistance (winding to ambient) is for the unit, mounted to a 254mm x 254mm x 12.7mm (10in x 10in x 0.5in) aluminum plate.

(1) These specifications refer to the output of the GM assembly.

When programming a digital amplifier for use with a GM assembly, these specifications must be adjusted by the ratio to create actual motor performance

Specification are subject to change without notice

Single Stack - 160 volt

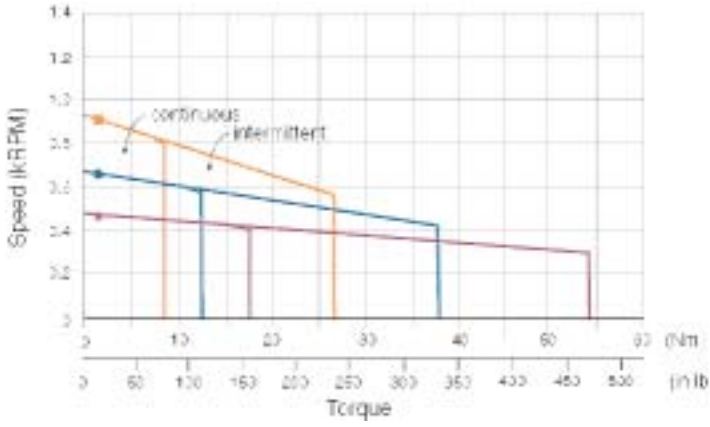

Single Stack - 300 volt

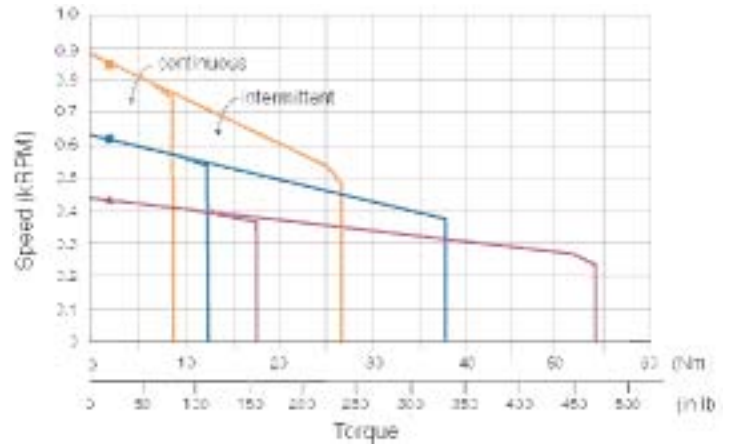

5:1 ———●——— 7:1 ———●——— 10:1 ———▲———

Double Stack - 160 volt

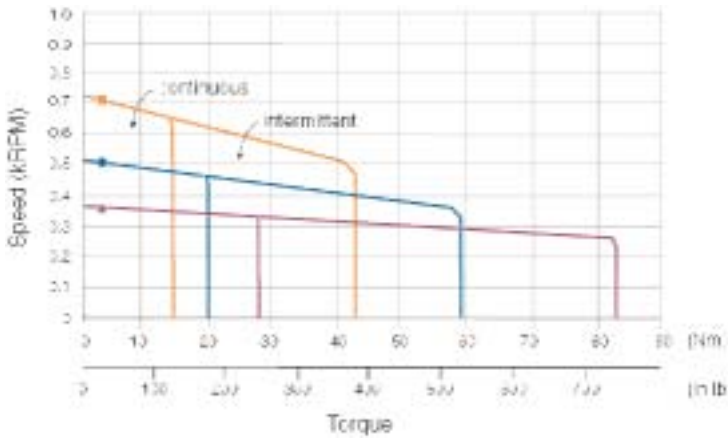

Double Stack - 300 volt

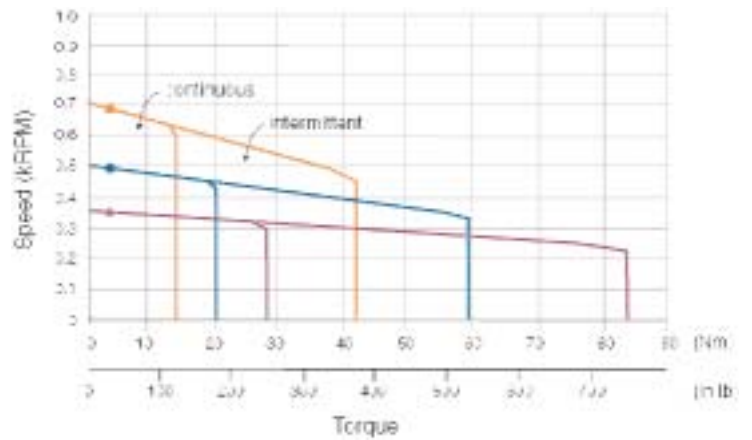

Performance Specifications

Mechanical Specifications

Frame Size	Stack Length	Weight without Brake		Maximum Radial Load		Torsional Stiffness		Standard Backlash (arc min)	Low Backlash (arc min)
		(kg)	(lb)	(N)	(lb)	(Nm/arc min)	(in lb/arc min)		
GM115	Single	8.4	18.5	3900	876	20	177	15	10
GM115	Double	10.6	23.4	3900	876	20	177	15	10

Single Stack Specifications

Frame Size	Ratio	Max. Speed ⁽¹⁾ (RPM)	Cont. Stall Torque ⁽¹⁾ T _C		Peak Torque ⁽¹⁾ T _P		Winding C:160 Vdc D:300 Vdc	Voltage Constant ⁽¹⁾ K _E (V/kRPM)	Torque Constant ⁽¹⁾ K _T		Induct L (mH)	Cold Resistance R (ohms)	Cont. Current I _C (amps)	Peak Current I _P (amps)	Inertia	
			(Nm)	(in lb)	(Nm)	(in lb)			(Nm/amp)	(in lb/amp)					(gm cm sec ²)	(lb in sec ²)
GM115	5:1	700	18.2	162.0	54.7	486.0	C	228.0	2.15	19.5	2.9	1.2	12	8	25	0.00375
GM115	5:1	680	18.2	162.0	54.7	486.0	D	438.0	4.15	37.0	10.7	4.7	12	4	13	0.00375
GM115	7:1	500	25.4	227.0	76.6	681.0	C	319.2	3.01	27.3	2.9	1.2	12	8	25	0.00306
GM115	7:1	480	25.4	227.0	76.6	681.0	D	613.2	5.81	51.8	10.7	4.7	12	4	13	0.00306
GM115	10:1	350	36.5	324.0	109.4	972.0	C	456.0	4.30	39.0	2.9	1.2	12	8	25	0.00306
GM115	10:1	340	36.5	324.0	109.4	972.0	D	876.0	8.30	74.0	10.7	4.7	12	4	13	0.00306

Double Stack Specifications

Frame Size	Ratio	Max. Speed ⁽¹⁾ (RPM)	Cont. Stall Torque ⁽¹⁾ T _C		Peak Torque ⁽¹⁾ T _P		Winding C:160 Vdc D:300 Vdc	Voltage Constant ⁽¹⁾ K _E (V/kRPM)	Torque Constant ⁽¹⁾ K _T		Induct L (mH)	Cold Resistance R (ohms)	Cont. Current I _C (amps)	Peak Current I _P (amps)	Inertia	
			(Nm)	(in lb)	(Nm)	(in lb)			(Nm/amp)	(in lb/amp)					(gm cm sec ²)	(lb in sec ²)
GM115	5:1	570	30.1	267.0	90.2	801.0	C	280.5	2.70	23.5	2.2	0.73	12	11	33	0.00544
GM115	5:1	650	30.1	267.0	90.2	801.0	D	455.5	4.35	38.5	5.8	1.9	12	7	21	0.00544
GM115	7:1	400	42.0	373.0	125.9	1119.0	C	392.7	3.78	32.9	2.2	0.73	12	11	33	0.00475
GM115	7:1	470	42.0	373.0	125.9	1119.0	D	637.7	6.09	53.9	5.8	1.9	12	7	21	0.00475
GM115	10:1	280	60.0	533.0	179.9	1599.0	C	561.0	5.40	47.0	2.2	0.73	12	11	33	0.00475
GM115	10:1	320	60.0	533.0	179.9	1599.0	D	911.0	8.70	77.0	5.8	1.9	12	7	21	0.00475

Note: Pole Count for GM115 is 12

Thermal Resistance for GM115 is 0.95 °C/W

Stator winding thermal resistance (winding to ambient) is for the unit, mounted to a 254mm x 254mm x 12.7mm (10in x 10in x 0.5in) aluminum plate.

(1) These specifications refer to the output of the GM assembly.

When programming a digital amplifier for use with a GM assembly, these specifications must be adjusted by the ratio to create actual motor performance

Specification are subject to change without notice

Single Stack - 160 volt

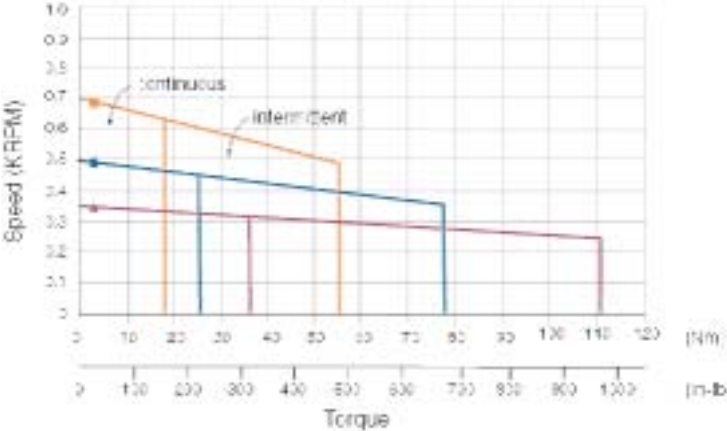

Single Stack - 300 volt

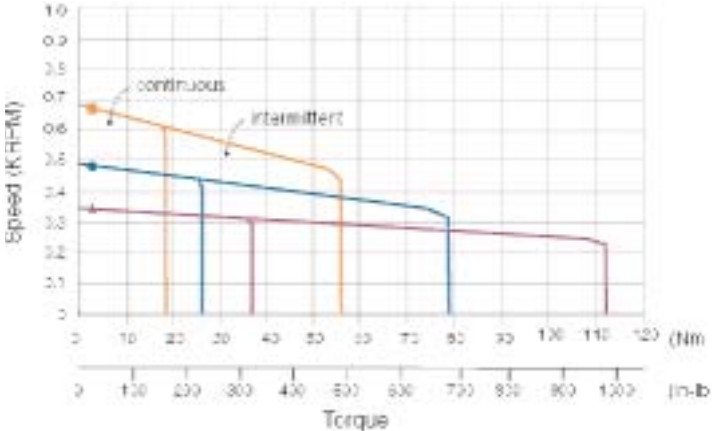

5:1 ———■——— 7:1 ———●——— 10:1 ———▲———

Double Stack - 160 volt

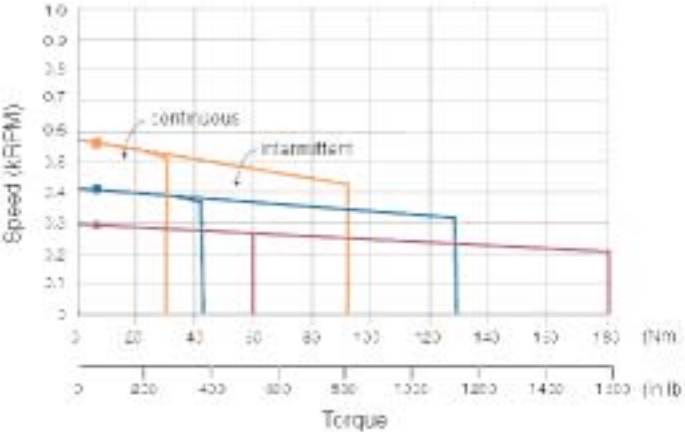

Double Stack - 300 volt

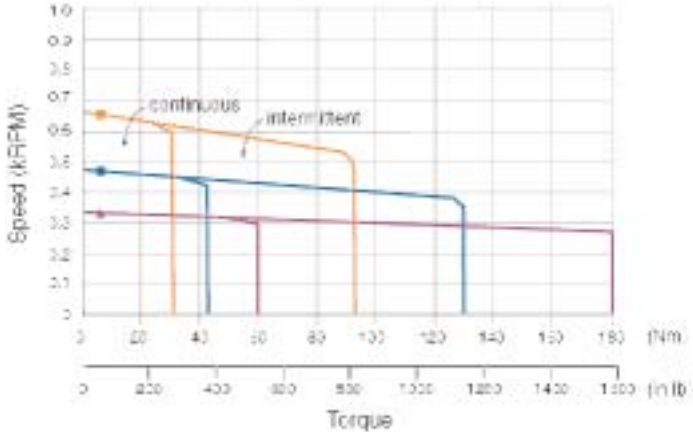

Maximum case temperature: the case temperature must not exceed 100 deg C for any combination of ambient temperature and RMS dissipation.

All motor speed/torque curves are based on 25 deg C ambient with a winding temperature of 155 deg C, at stall. Ambient temperatures above 25 deg C will require derating. Consult Bayside Motion Group, Technical Services at (516) 484-5482, ext. 130 for application assistance.

Encoder

Starting with Serial Number 01499 the encoder line count is 2000 providing 8000 pulses per revolution, post quadrature and commutation signals. For Serial Number prior to 01499 the encoder line count is 1000 providing 4000 pulses per revolution, post quadrature and commutation signals.

Rotary Encoder Specifications (All Frame Sizes)

Resolution	2,000 Line (8,000 LPR)
Electrical Input:	5 Vdc, 125 ma maximum (plus interface loads)
Encoder Output:	A, B, I, \bar{A} , \bar{B} , \bar{I} Differential, TTL compatible Frequency Response 125 KHz

Environmental Conditions

Operating Temperature -40 to 100 deg C
 Storage Temperature -40 to 100 deg C

Signal Timing

The following chart shows the timing of the commutation and encoder signals in relation to the motor bmf. See section IV, Wiring, for signal pin designations.

Motor Signal Timing (C/D winding)
at motor cable lead end

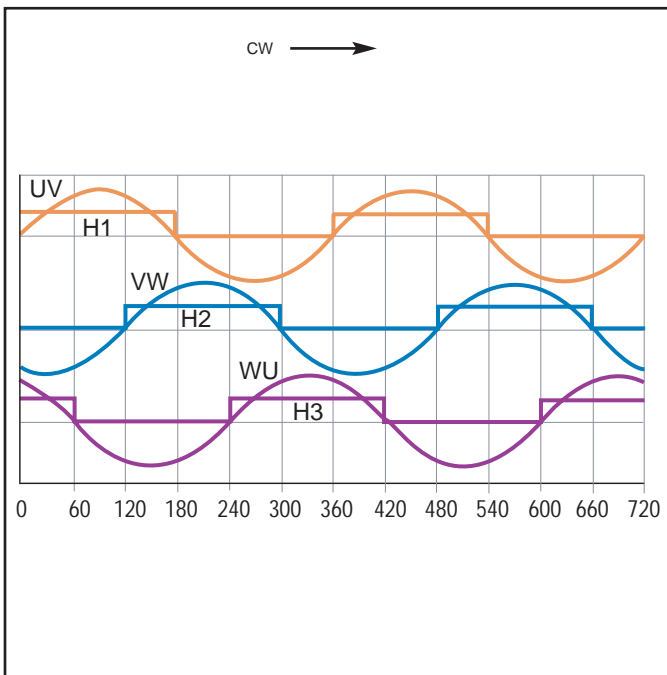

Encoder Timing

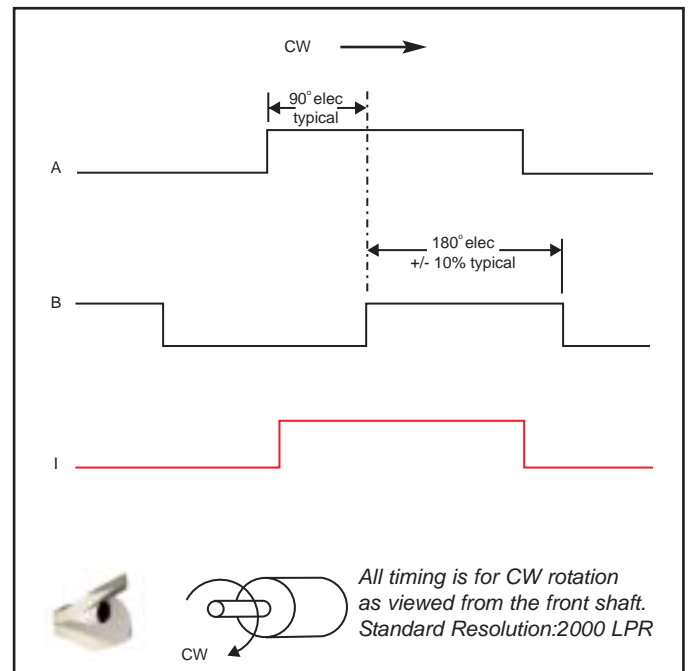

Resolver

The standard brushless resolver is for use with typical R/D (resolver to digital) converters. The resolver is a single cycle type, having 1 resolver cycle per revolution of the motor shaft. This results in “R” resolver cycles per revolutions of the output shaft, where “R” is the gearmotor ratio.

Resolver Specification (All Frame Sizes)

Frequency	Hz	5,000
Input Voltage	Vrms	4.0
Input Current	ma max.	23
Input Power	Watts nom.	0.045
Transformation Ratio	± 10%	0.50
Output voltage	Vrms	2.0
Sensitivity	mv / Deg	35

Environmental Conditions

Operating Temperature -55 to 155 deg C

Signal Timing

The start of the S1-S3 resolver signal is coincident with the start of the X-Y bemb motor signal.

Brake

The brake is fail safe type, i.e. braking action occurs when power is removed. Therefore, for gearmotor rotation, the brake must be electrically energized.

Brake Specification

Frame Size	Static Holding Torque		Voltage (V)	Current (amps)	Res (ohms)
	(Nm)	(in lb)			
GM060	0.33	3.0	24 Vdc	0.19	131
GM090	5.64	50	24 Vdc	0.30	65
GM115	5.64	50	24 Vdc	0.30	65

IV. Wiring

Motor Power Connector (DIN Connector)

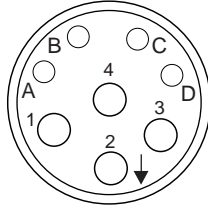

Power Connector Details

Pin Number	Function	Mating Cable Color Code
1	U	Black #1
4	V	Black #2
3	W	Black #3
2	Chassis Gnd.	Yellow / Green
A	Thermistor +	Black #5
B	Thermistor -	Black #6
C	Brake +	Black #7
D	Brake -	Black #8
-	Shield	Drain

Motor Power Mating Connector

Manufacturer	Part Number	Description
Hypertac	LPNA08BFRKB170	Body
	020.232.2000	4 Pins Female 18-26 AWG
	020.090.1020	4 Pins Female 16-20 AWG

Cables



Mating Power Cable

Part Number	Length	Used With
10963093	3 meter	Flying Leads
10963117	8 meter	Flying Leads

Motor Sensor Connector (DIN Connector)



Pin Number	Function		Mating Cable	
	Encoder	Resolver	Flying Lead Color Code	i-Drive Conn. Pin Number
1	A +	S1 (SIN+)	Black	1
2	B +	S4 (COS+)	Red	2
7	+5V	R2 (Ref+)	Brown/Green	7
8	Shield	Shield	Shield	8
9	A -	S3 (SIN-)	Violet	9
10	B -	S2 (COS-)	Blue	10
15	Gnd	R1 (REF-)	White/Green	15
12	Spare	Spare	Gray/Pink	—
5	I +	—	Brown	5
13	I -	—	White	13
3	Hall 1 (S1)	—	Yellow	—
11	Hall 2 (S2)	—	Green	—
4	Hall 3 (S3)	—	Red/Blue	—
16	Thermistor +	Thermistor +	White/Yellow	—
17	Thermistor -	Thermistor -	Yellow/Brown	—
6 & 14	No Connection			

Motor Sensor Mating Connector

Manufacturer	Part Number	Description
Hypertac	SPNA17HFRON	Body
	020.256.1020	17 Pins Female

Cables

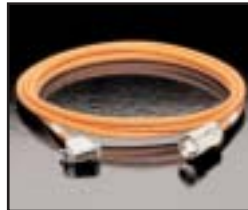

Mating Sensor Cable

Part Number	Length	Used With
10963094	3 meter	Flying Leads
10963096	3 meter	i-Drive
10963123	8 meter	Flying Leads
10963118	8 meter	i-Drive
10963136 ⁽¹⁾	N / A	i-Drive / Controller

(1) NOTE: When an external controller is used in a closed loop mode an additional sensor cable, part number 10963136, is required.

IV. Wiring

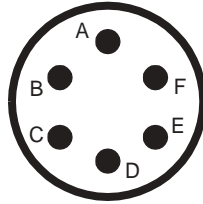

060 Serial Motor Power connector (MIL Connector)

090/115/142 Serial Motor Power connector (MIL Connector)

Power Connector Details

Pin Number	Function	Mating Cable Color Code
A	U	Red
B	V	Black
C	W	White
D	Chassis Gnd.	Green
E	Brake +	Orange
F	Brake -	Blue
--	Shield	Drain

Power Connector Details

Pin Number	Function	Mating Cable Color Code
A	U	Black #1
B	V	Black #2
C	W	Black #3
D	Chassis Gnd.	GRN/YLW
E	Brake +	Black #4
F	Brake -	Black #5
G	Spare	--
--	Spare	Black #6
--	Shield	Drain

Motor Power Mating Connector

Manufacturer	Part Number	Description
Connon/ITT Industries	KPT06J106S	North America Circular MIL - C - 26482 Series I KPT / KPSE

Motor Power Mating Connector

Manufacturer	Part Number	Description
Connon/ITT Industries	CA3106E20-15S-B	Euro Circular CA-Bayonet/VG95234 Circular Signal and Power Connectors

Cables



Mating Power Cable

Part Number	Length	Used With
10963012_3000	3 meter	Flying Leads
10963013_8000	8 meter	Flying Leads

Cables



Mating Power Cable

Part Number	Length	Used With
10963021_3000	3 meter	Flying Leads
10963021_8000	8 meter	Flying Leads

060/090/115/142 Motor Sensor Connector (MIL Connector)

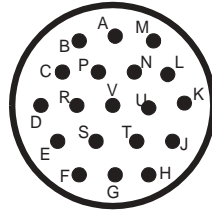

Pin Number	Function	Mating Cable	
		Flying Lead Color Code	i-Drive Conn. Pin Number
E	A +	Orange	1
A	A-	Black w/Org	9
F	B+	Yellow	2
J	B-	Black w/Ylw	10
H	I+	Blue	5
K	I-	Black w/Blue	13
B	Hall 1	White	-
C	Hall 2	Green	-
D	Hall3	Brown	-
L	+5V	Red	7
N	GND	Black w/Red	15
M	T1	Black w/White	-
P	T2	Black w/Grn	-
S	Spare	Black w/Brn	-
SHIELD	Shield	Drain	8

Pin Number	Function	Mating Cable for Resolver
		Flying Lead Color Code
A	R1 (Ref+)	Black w/Red
E	R2 (Ref-)	Red
J	S1 (Cos+)	Black w/Wht
K	S3 (Cos-)	White
F	S2 (Sin+)	Black w/Grn
H	S4 (Sin-)	Green
M	T1	Black w/Blue
P	T2	Blue
Shield	Shield	Drain

Motor Sensor Mating Connector

Manufacturer	Part Number	Description
Connon/ITT Industries	KPT06J1419S	North America Circular MIL-C-26482 Series I KPT/KPSE

Cables



Mating Sensor Cable

Part Number	Length	Used With
10963011_3000	3 meter	Flying Leads/Encoder
10963119_3000	3 meter	i-Drive/Encoder
10963011_8000	8 meter	Flying Leads/Encoder
10963119_8000	8 meter	i-Drive/Encoder
10963073_3000	3 meter	Flying Leads/Resolver
10963073_8000	8 meter	Flying Leads/Resolver
10963136(1)	0.3+0.3 meter	i-Drive / Controller

(1) NOTE: When an external controller is used in a closed loop mode an additional sensor cable, part number 10963136, is required.

Motor Power/Sensor Connections (Flying Lead option)

Sensor Wiring Details

Function		Wire Color
Encoder	Resolver	
A +	S1 (SIN+)	Brown
B +	S4 (COS+)	Blue
+5V	R2 (Ref+)	Red
Shield	Shield	Shield
A -	S3 (SIN-)	White
B -	S2 (COS-)	Green
Gnd	R1 (REF-)	Black
Spare	Spare	-
I +	—	Orange
I -	—	Yellow
Hall 1 (S1)	—	White/Brown
Hall 2 (S2)	—	White/Orange
Hall 3 (S3)	—	Violet
Thermistor +	Thermistor +	White/Red
Thermistor -	Thermistor -	White/Black
No Connection		

Power Wiring Details

Function	Color
U	White
V	Black
W	Red

V. Mechanical Specifications (DIN Connector Series)

Dimensions

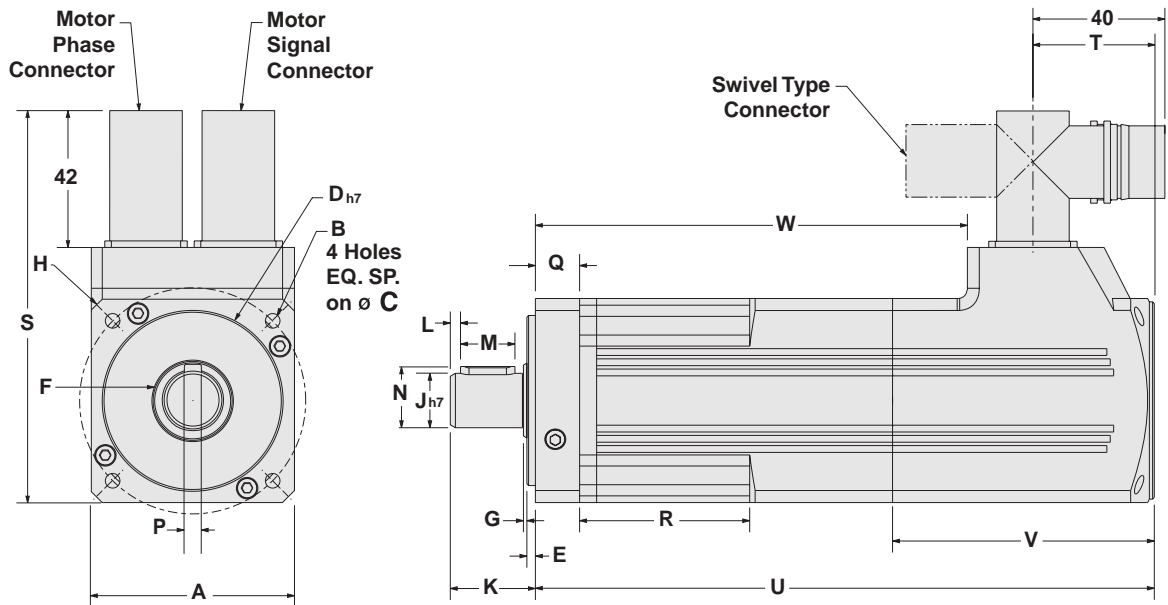

METRIC SIZES

Frame Size	A		B		C		D		E		F		G		H		J	
	mm	in	mm	in	mm	in	mm	in	mm	in	mm	in	mm	in	mm	in	mm	in
GM060	60	2.36	5.5	0.22	70	2.756	50	1.969	2.5	0.1	23	0.91	1.0	0.04	80	3.15	16	0.63
GM090	90	3.54	6.5	0.26	100	3.94	80	3.15	3.0	0.12	36	1.42	1.0	0.04	116	4.57	20	0.79
GM115	115	4.53	8.5	0.33	130	5.12	110	4.33	3.5	0.14	36	1.42	1.5	0.6	152	5.95	24	0.94

Frame Size	K		L		M		N		P		Q		R		S		T	
	mm	in	mm	in	mm	in	mm	in	mm	in	mm	in	mm	in	mm	in	mm	in
GM060	25.0	0.98	3	0.118	16	0.630	18.0	0.709	5	0.20	13	0.51	50.0	1.969	117	4.60	37	1.457
GM090	40.0	1.57	5	0.20	28	1.10	22.5	0.886	6	0.24	17	0.67	54.5	2.15	147	5.79	39	1.535
GM115	50.0	1.97	7	0.28	32	1.26	27.0	1.063	8	0.32	20	0.79	55.5	2.18	175	6.89	46	1.811

NEMA SIZES

Frame Size	B		C		D		J		K		M		N		P	
	Bolt Hole		Bolt Circle		Pilot Diameter		Output Shaft Diameter		Output Shaft Length		Keyway Length		Keyway Height		Keyway Width	
	(in)	(mm)	(in)	(mm)	(in)	(mm)	(in)	(mm)	(in)	(mm)	(in)	(mm)	(in)	(mm)	(in)	(mm)
GM023	0.195	5.0	2.625	66.7	1.500	38.1	0.375	9.5	1.000	25.4	0.750 flat	19.1 flat	0.015 flat	0.4 flat	—	—
GM034	0.218	5.5	3.875	98.4	2.875	73.0	0.500	12.7	1.250	31.8	1.063	27.0	0.072	1.8	0.125	3.2
GM042	0.281	7.1	4.950	125.7	2.187	55.5	0.625	15.9	1.500	38.1	1.130	28.7	0.108	2.7	0.188	4.8

Options

	U		V		W	
	Length		Rear Cover Length		Flange Offset	
	(mm)	(in)	(mm)	(in)	(mm)	(in)
GM060 Single Stack – Encoder or Resolver	178	7.01	70	2.76	121	4.76

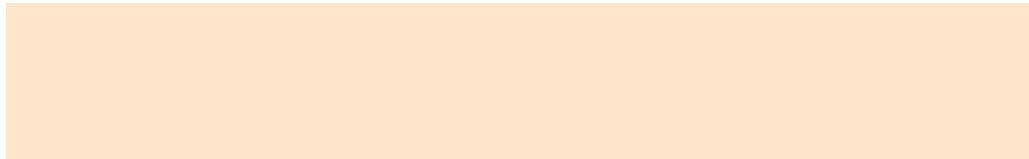

VI. Maintenance & Lubrication

Your Gearmotor is pre-filled with an oil lubricant. To assure the proper operational life of the gearhead, oil should be changed after every 10,000 hours of operation or annually, whichever comes first.

The oil is a synthetic gear oil and can be replaced with either:

Nye Lubricants	SGO 345 or
Mobil	SHC 630

To properly change the oil in the gearmotor:

1. Drain the existing oil through the fitting on the mounting flange.
2. Refill the gearmotor with one of the approved lubricants above
3. Run the unit slowly to free up any particles and drain the unit a second time
4. Refill the gearmotor with one of the approved lubricants above

Fill Quantities

GM60	25 ml
GM90	55 ml
GM115	125 ml