

ACR1500 INTERCONNECT BLOCK AND EXAMPLES

ENCODER INPUT

Encoder Inputs to the ACR1500 are capable of handling various types of open-collector and line driver encoders
DO NOT USE WITH CMOS DRIVERS

TYPICAL ENCODER

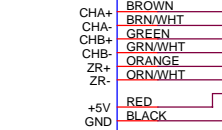

CAUTION: Before hook-up consult manual for jumper settings required on ACR1500
Improper settings may cause PERMANENT DAMAGE to encoder

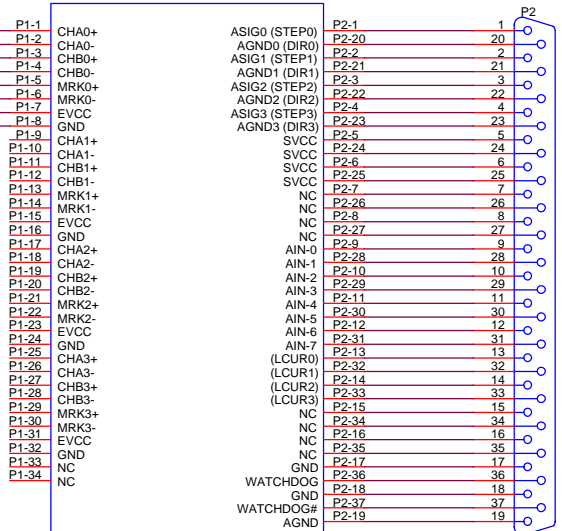

CONNECTOR DB37

TTL DIGITAL INPUT/OUTPUTS

The P3 and P4 50-pin connectors are compatible with Opto-22 input and output racks for opto-isolation of all TTL inputs and outputs.

TTL DIGITAL INPUT/OUTPUTS

The P3 and P4 50-pin connectors are compatible with Opto-22 input and output racks for opto-isolation of all TTL inputs and outputs.

WATCHDOG CIRCUIT

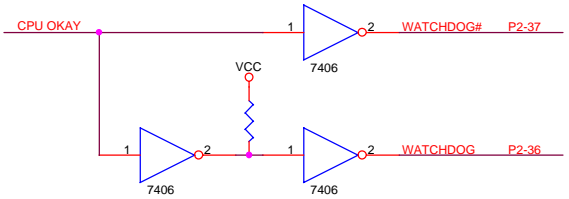

Watchdog Open-Collector Signal Drive Rating:
30milliamps, maximum

See sheet 2 for DAC/Stepper interface information.
See sheet 3 for P2 DAC/Stepper connector wiring examples.
See sheet 4 and 5 for Watchdog user-implementation wiring examples.
See sheet 4 and 5 for P2 Analog Input connector wiring examples.
Connections made to high density male 37-pin D-plug supplied.

Analog/Stepper Wiring

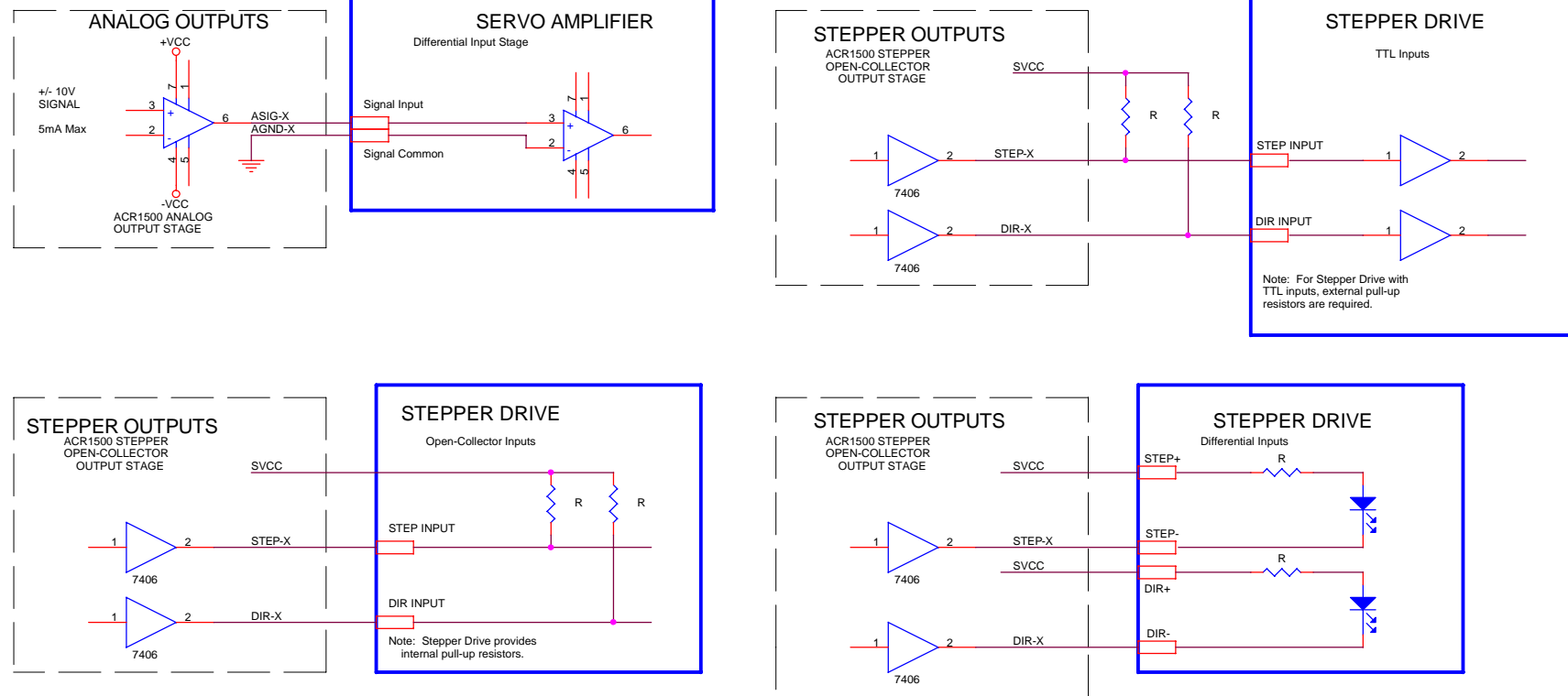

Encoder Wiring

Differential Input

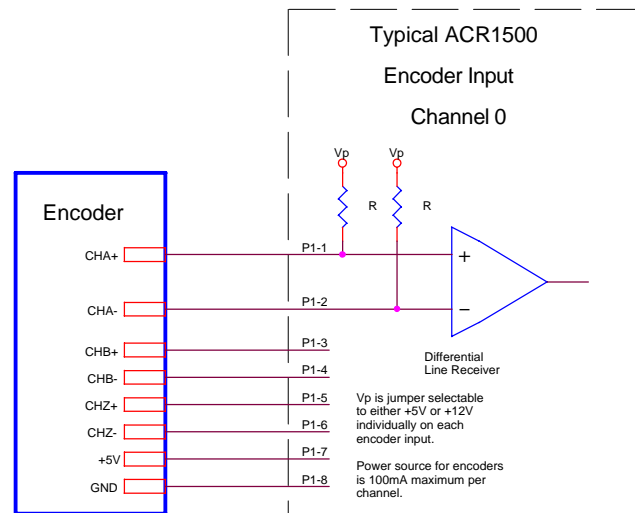

Single-Ended Input

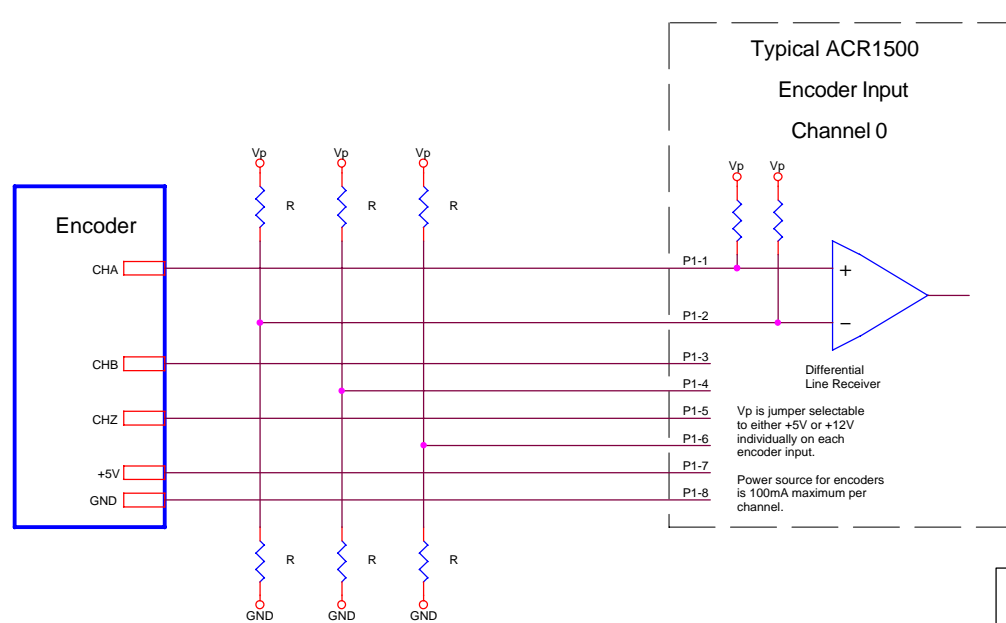

NOTE: External resistor (R) value is:
Vp @ 5V, R = 1K ohm
Vp @ 12V, R = 2K ohm

ANALOG P2 CONNECTOR OUTPUT WIRING EXAMPLE

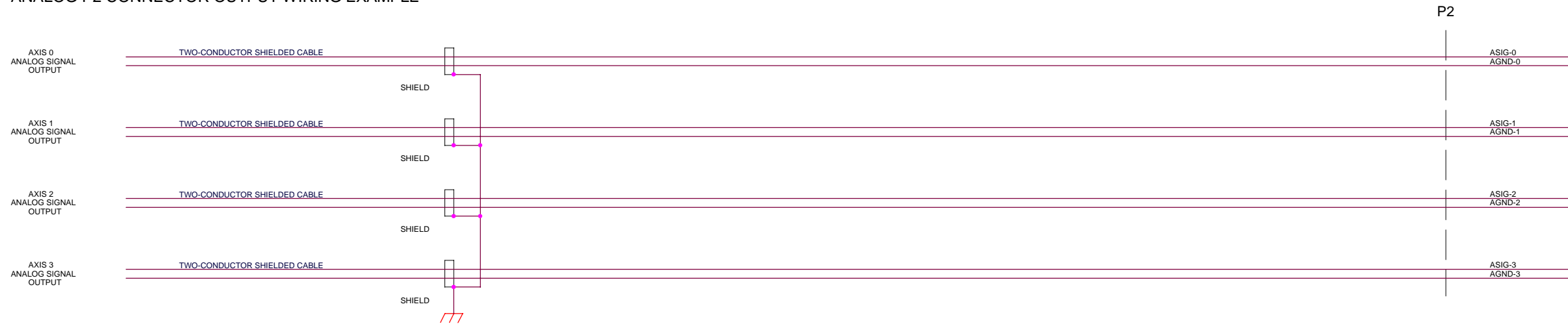

STEPPER P2 CONNECTOR DIFFERENTIAL OUTPUT WIRING EXAMPLE (OPEN-COLLECTOR OUTPUTS PULLED-UP THRU STEPPER DRIVE INPUTS)



STEPPER P2 CONNECTOR SINGLE-ENDED OUTPUT WIRING EXAMPLE (OPEN-COLLECTOR OUTPUTS PULLED-UP TO +5V THRU EXTERNAL RESISTORS)

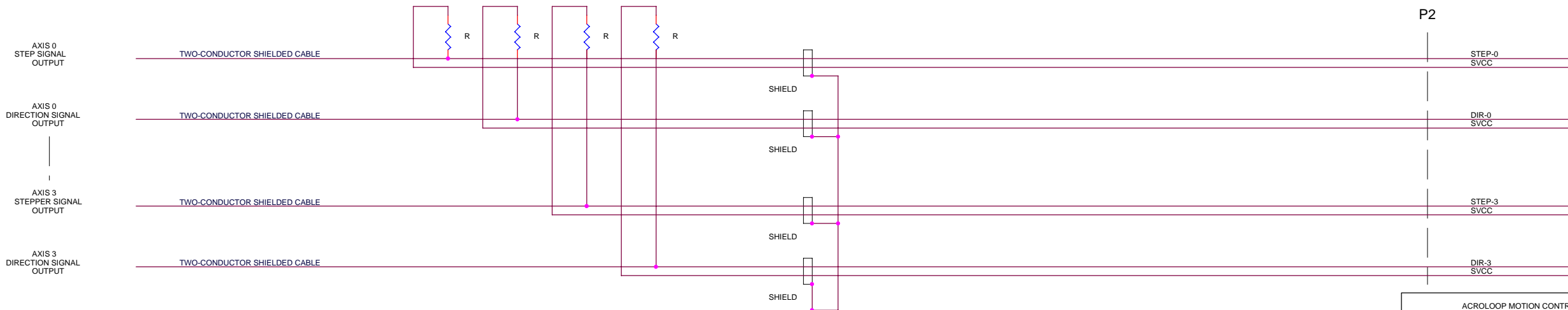

NOTE: EXTERNAL RESISTORS, R, ARE PROVIDED BY THE USER.
 THE VALUE OF R IS DETERMINED BY THE CURRENT SPECIFIED FOR THE STEPPER DRIVE INPUTS. RESISTOR R SHOULD BE SELECTED SO THAT THE MAXIMUM OUTPUT CURRENT OF THE ACR2000 STEPPER BOARD DOES NOT EXCEED 30mA PER OUTPUT.

ACROLOOP MOTION CONTROL SYSTEMS INC. 3650 Chestnut Street, North Chaska, MN USA 55318	
Title ACR1500 WIRING EXAMPLE	
Size C	Document Number ACR15KID3.SCH
Date: Wednesday, September 15, 1999	Sheet 3 of 5
	Rev B

ANALOG P2 CONNECTOR INPUT WIRING

DIFFERENTIAL WIRING EXAMPLE

ANALOG TO DIGITAL INPUTS (ADC)

ANALOG TO DIGITAL INPUTS (AIN0 - AIN7) CAN BE USED AS DIFFERENTIAL OR SINGLE-ENDED INPUTS. ANY COMBINATION MAY BE USED.

IF USED AS DIFFERENTIAL INPUTS, TWO INPUTS ARE USED AS SHOWN USING AIN0-AIN1 & AIN2-AIN3. FOUR DIFFERENTIAL INPUT SIGNALS MAY BE USED WITH AN ACR1500.

IF USED AS SINGLE-ENDED INPUTS, ONE INPUT IS USED IN CONJUNCTION WITH AIN-COM. EIGHT SINGLE-ENDED INPUT SIGNALS MAY BE USED WITH AN ACR1500. SEE SHEET 4 FOR SINGLE ENDED WIRING EXAMPLE.

DIFFERENTIAL INPUT PAIRS

+	-
AIN0 - AIN1	
AIN2 - AIN3	
AIN4 - AIN5	
AIN6 - AIN7	

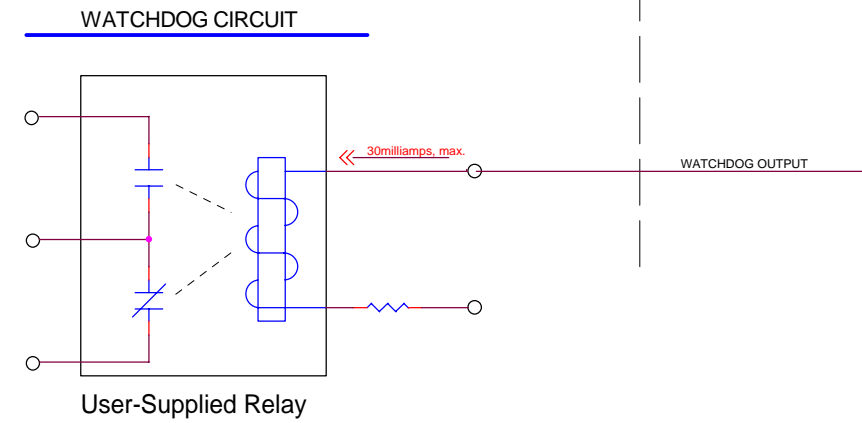

WATCHDOG OUTPUT USED TO DISABLE SERVO DRIVE UNTIL ACR1500 CONTROLLER HAS FULL CONTROL OF ALL DIGITAL AND ANALOG SIGNALS TO PREVENT POSSIBLE MOTOR SURGE ON INITIAL START-UP

ACROLOOP MOTION CONTROL SYSTEMS INC. 3650 Chestnut Street, North Chaska, MN USA 55318		
Title ACR1500 WIRING EXAMPLE		
Size C	Document Number ACR15KID4.SCH	Rev B
Date: Monday, October 04, 1999	Sheet 4	of 5

ANALOG P2 CONNECTOR INPUT WIRING

SINGLE-ENDED WIRING EXAMPLE

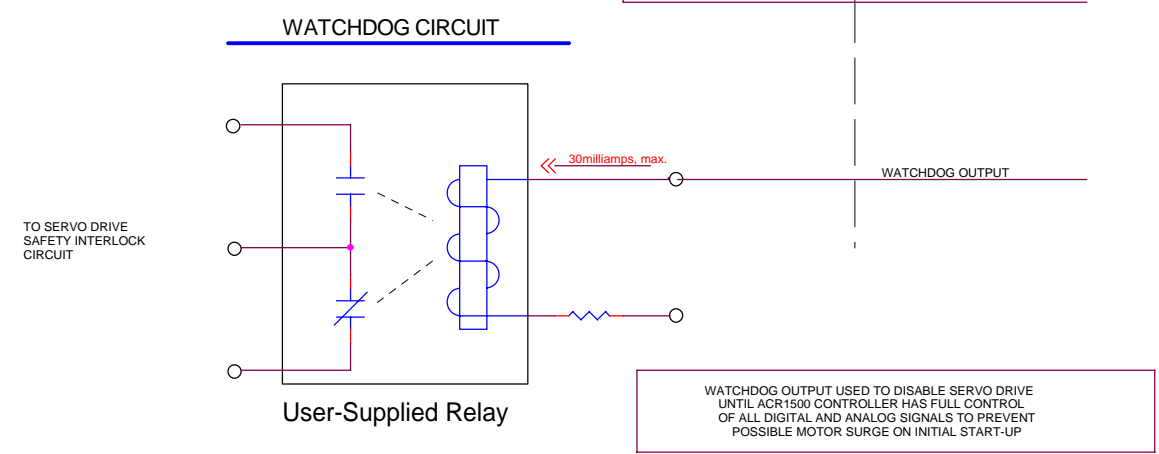
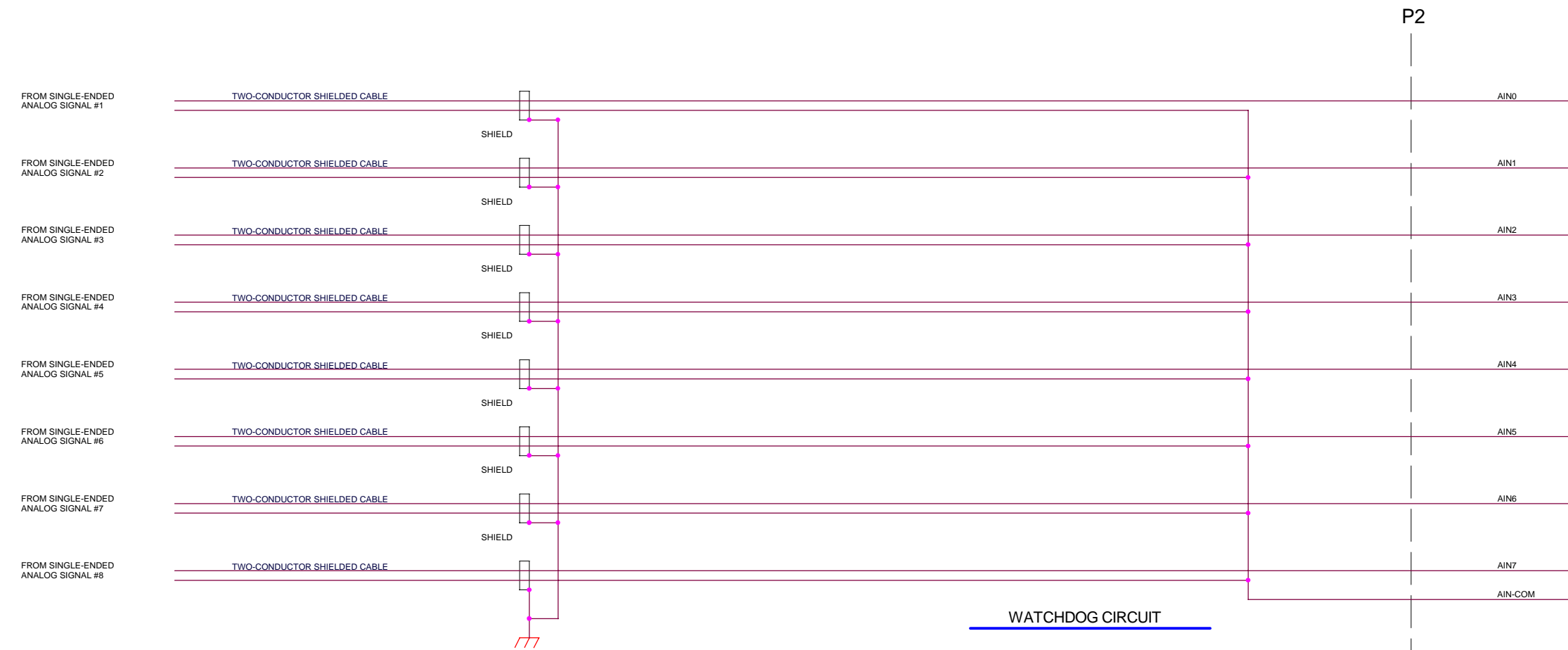

ACROLOOP MOTION CONTROL SYSTEMS INC. 3650 Chestnut Street, North Chaska, MN USA 55318			
Title ACR1500 WIRING EXAMPLE			
Size C	Document Number ACR15KID5.SCH	Rev B	
Date: Monday, October 04, 1999	Sheet 5	of 5	