



Product Type Aries AR-01xR, 02xR, 04xR, 08xR, and AR-13xR

The above product complies with the requirements of directives

- EMC Directive 89/336/EEC
- Low Voltage Directive 73/23/EEC
- CE Marking Directive 93/68/EEC

Provided the installation requirements described in the *Aries User Guide* are met, and there are no special requirements of the installation and operating environment so that the application may be considered typical.

The above equipment conforms with the protection requirements of Council Directive 89/336/EEC as amended by Directive 92/31/EEC on the approximation of the laws of the Member States relating to Electromagnetic Compatibility when installed, operated and maintained as intended. Also: -The above equipment conforms with the requirements of Council Directive 73/23/EEC (Low Voltage Directive) as amended by Directive 93/68/EEC (CE Marking Directive), when installed, operated, and maintained as intended.

In accordance with IEC 61800-3:1997 (Adjustable speed electrical power drive systems) this product is of the restricted sales distribution class which meets the needs of an industrial environment when installed as directed. However, further measures may need to be taken for use of the product in a domestic environment.

The installation requirements are detailed in the Information supplied with the equipment. The equipment is sold only to competent system builders.

Aries

Quick Reference Guide

AR-01xR, 02xR, 04xR, 08xR, and 13xR

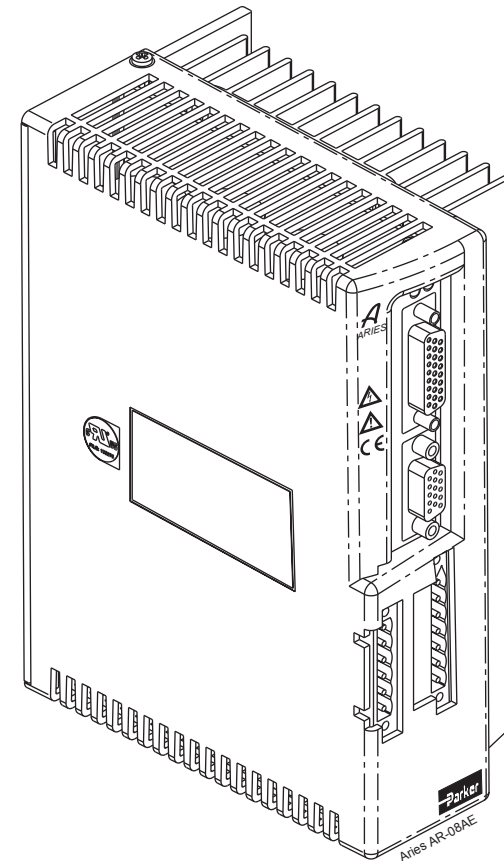

Safety Warning!



High-performance motion control equipment is capable of producing rapid movement and very high forces. Unexpected motion may occur especially during the development of controller programs. KEEP WELL CLEAR of any machinery driven by stepper or servo motors. Never touch any part of the equipment while it is in operation.

This product is sold as a motion control component to be installed in a complete system using good engineering practice. Care must be taken to ensure that the product is installed and used in a safe manner according to local safety laws and regulations. In particular, the product must be positioned such that no part is accessible while power may be applied.

This and other information from Parker Hannifin Corporation, its subsidiaries, and authorized distributors provides product or system options for further investigation by users having technical expertise. Before you select or use any product or system, it is important that you analyze all aspects of your application and review the information concerning the product in the current product catalog. The user, through its own analysis and testing, is solely responsible for making the final selection of the system and components and assuring that all performance, safety, and warning requirements of the application are met.

If the equipment is used in any manner that does not conform to the instructions given in this user guide, then the protection provided by the equipment may be impaired.

Electromechanical Division
Parker Hannifin Corporation
p/n 88-027033-01A
Effective: June 2006



RS-232/485 Configuration

The 26-pin DRIVE I/O connector (female D-subminiature) also functions as the communications (COM) port.

Drive I/O Connector configuration for RS-232

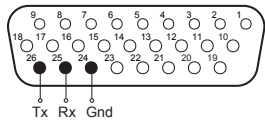

Drive I/O Connector configuration for RS-485

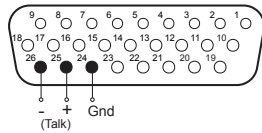

Aries

AR-01xR to AR-13xR Servo Drives w/ Step and Direction

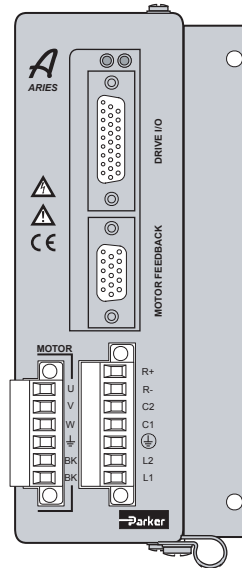

Website

<http://www.parkermotion.com>

Drive LED Status Indicators

LED-Left

Off
Green
Yellow
Off
Yellow
Off
Yellow (flash)
Yellow
Yellow & 1 Green (flash)
Yellow & 2 Green (flash)
Yellow & 3 Green (flash)
Yellow & 4 Green (flash)

LED-Right

Green
Yellow/Green (alternating)
Green
Red
Off
Red (flash)
Red (flash)
Red
Red
Red
Red
Red

Drive Status-What it means

Power on, enabled
Autorun mode
Power on, regeneration active
Power on, disabled-No Fault
Power on, boot process
Waiting for OS download
OS download in process
Control power mode active
Bridge Fault
Feedback Fault
Thermal Fault
Other Fault

Drive I/O Connector

Motor Feedback Connector

NOTE: A box surrounding the pins indicates a requirement for twisted pair wiring.

Signal	Pin
ENABLE+	1
ENABLE-	21
DGND	2
ENC A+	3
ENC A-	4
ENC B+	5
ENC B-	6
ENC Z+	7
ENC Z-	8
FAULT+	9
FAULT-	16
STEP+	10
STEP-	11
DIRECTION+	12
DIRECTION-	13
AIN+	14
AIN-	15
DGND	17
RESET+	18
RESET-	23
DGND	19
DGND	20
DGND	22
DGND	24
RS-232Rx/RS-485+	25
RS-232Tx/RS-485-	26

Signal	Pin
No Connection	1
No Connection	2
Thermal-	3
Reference+	4
Reference-	15
No Connection	5
Thermal-	6
Thermal+	10
SIN-	7
SIN+	8
No Connection	9
COS-	11
COS+	12
No Connection	13
No Connection	14

* When using the SinCos protocol, pins 9 and 13 require twisted pair wiring.

Output Power Connector

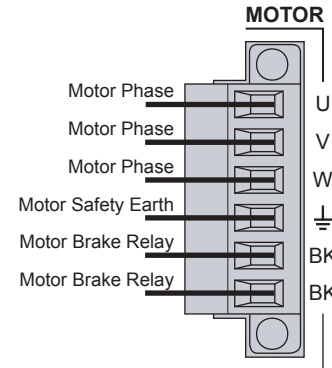

Motor Input Power

120/240 VAC, 50/60 Hz, Single phase

Mains Power Connector

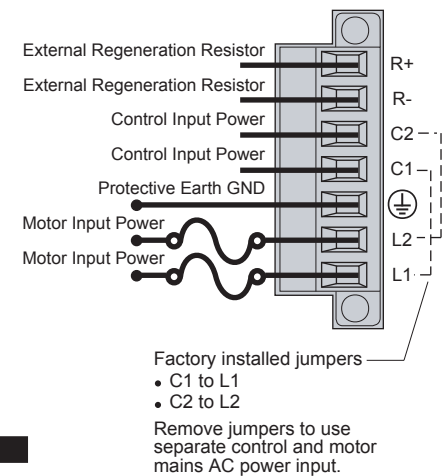

Factory installed jumpers
 • C1 to L1
 • C2 to L2
 Remove jumpers to use separate control and motor mains AC power input.



Warning!



- You must connect the drive's protective conductor terminal, marked with the earth symbol \oplus , to a reliable system Protective Earth.
 - The drive's connector strip terminals are at hazardous voltages when power is applied to the drive, and up to several minutes after power is removed. Lower voltages may still be present for several minutes after power is removed.
- During normal operation, these high voltage terminals must not be accessible to the user.

UL Standard of Compliance

508c

Fuse Information

Aries has no internal fuses. For safety, you must provide a fuse in each of the AC input lines. See Fuse Information in the Aries Hardware Installation Guide (included on the Aries CD).