

CHAPTER 5

Hardware Reference

The information in this chapter will enable you to:

- ❑ Find system specifications (dimensions and performance) quickly
- ❑ Find system settings (DIP switches) and configuration data (wiring) quickly

General Specifications

DR Series

Parameter	Value	
Performance		
Repeatability	±5 arc-sec (0.00139°)	
Accuracy	±30 arc-sec (0.0083°) DRA Series ±45 arc-sec (0.0125°) DRB, DRE Series	
Max stepping rate	1,600,000 steps/sec	
Power		
Volts	115VAC 1-phase, or 230 VAC 1-phase	
Range	+10% to -15%	
	50/60 Hz	
Current	20 amps max	
Inputs		
Command Interface		
Step input	Low going, low pulse, 150 nanoseconds minimum pulse width	
Direction	Logic high = CW rotation Logic low = CCW rotation	
Analog input	±10V command signal	
Outputs		
Encoder output	A/B encoder output 750 kHz max	
Environmental		
	Driver	Motor
Weight	13.2 lb (6 kg)	See Table
Operating	32° to 122°F (0° to 50°C)	32° to 113°F (0° to 45°C)
Storage	-4° to 185° F (-20° to 85°C)	-4° to 185° F (-20° to 85°C)
Humidity	20 to 90% noncondensing	20 to 85% noncondensing

No corrosive gasses. Dust free atmosphere. The Dynaserv is not waterproof, oil proof, or dust proof.

DR5000 Series

Parameter	Value	
Performance		
	DR5000 "A" (10")	DR5000 "B" (6")
Repeatability	±5 arc-sec (0.00139°)	±10 arc-sec
Accuracy	±45 arc-sec (0.0125°)	±90 arc-sec
Max stepping rate	1,600,000 steps/sec	1,400,000 steps/sec
Power		
Volts	200VAC 3-phase	230 VAC 1-phase
Range	+10% to -15%	+5 to -15%
	50/60 Hz	50/60 Hz
Current	20 amps max	20 amps
Inputs (All Models)		
Command Interface	Step and direction—Position control ±10V DC—Velocity control	
Step input	low going pulse, 150 nanosecond minimum pulse width	
Direction	Logic high = CW rotation Logic low = CCW rotation	
Analog input	±10V DC max	
Other inputs (gain selection, servo on, etc.)	5 to 25 volts pullup	
Outputs (all Models)		
Encoder output	A, B Quadrature signal (400 KHz max) Z Channel—"A": 104 pulses/rev—"B": 68 pulses/rev	
Other outputs (in position, alarm, etc.)	TTL	
Environmental		
	Driver	Motor
Weight	24 lb (11 kg)	See Table
Operating	32° to 122°F (0° to 50°C)	32° to 113°F (0° to 45°C)
Storage	-4° to 185° F (-20° to 85°C)	-4° to 185° F (-20° to 85°C)
Humidity	20 to 90% noncondensing	20 to 85% noncondensing
No corrosive gasses. Dust free atmosphere. The Dynaserv is not waterproof, oil proof, or dust proof.		

DM Series

Parameter	Value	
Performance		
Repeatability	±2 arc-sec (0.00056°)	
Accuracy	±25 arc-sec (0.0069°)	
Max stepping rate	1,600,000 steps/sec	
Power		
Volts	115VAC 1-phase, or 230 VAC 1-phase	
Range	+10% to -15%	
	50/60 Hz	
Current	20 amps max	
Inputs		
Command Interface	Low going, low pulse, 150 nanoseconds minimum pulse width	
Step input	Logic high = CW rotation	
Direction	Logic low = CCW rotation	
Analog input	±10V command signal	
Outputs		
Encoder output	A/B encoder output 393 kHz max	
Environmental		
	Driver	Motor
Weight	13.2 lb (6 kg)	See Table
Operating	32° to 122°F (0° to 50°C)	32° to 113°F (0° to 45°C)
Storage	-4° to 185° F (-20° to 85°C)	-4° to 185° F (-20° to 85°C)
Humidity	20 to 90% noncondensing	20 to 85% noncondensing
No corrosive gasses. Dust free atmosphere. The Dynaserv is not waterproof, oil proof, or dust proof.		

DR5000 Motor Performance

The torque/speed curves represent the available peak torque. Continuous torques are approximately 2/3 of the peak value.

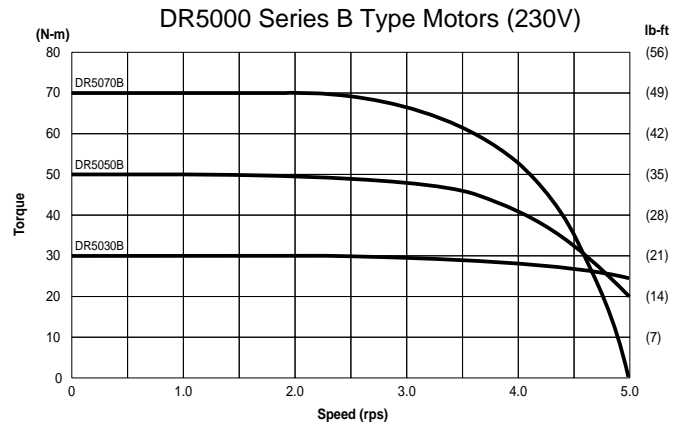
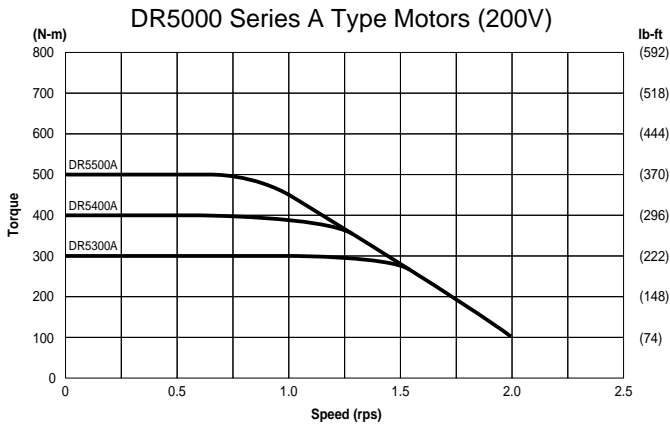
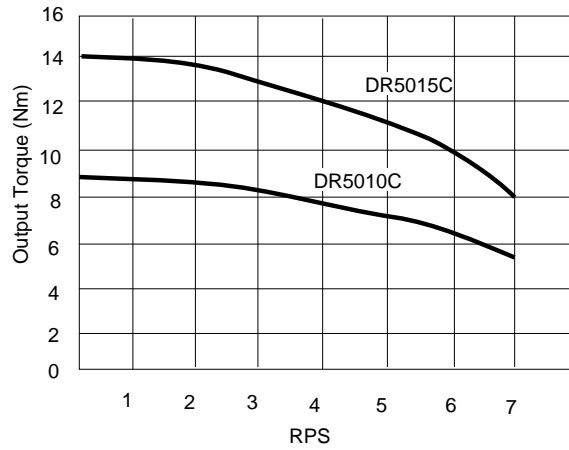

DR Motor Performance

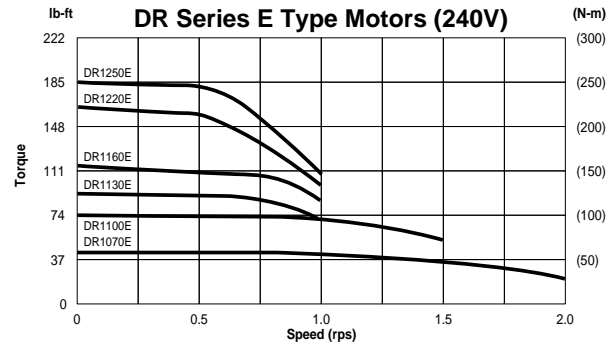
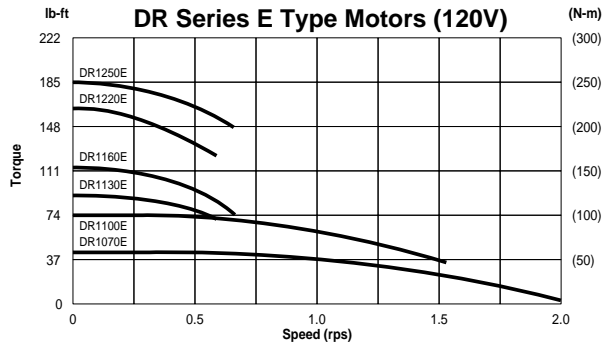
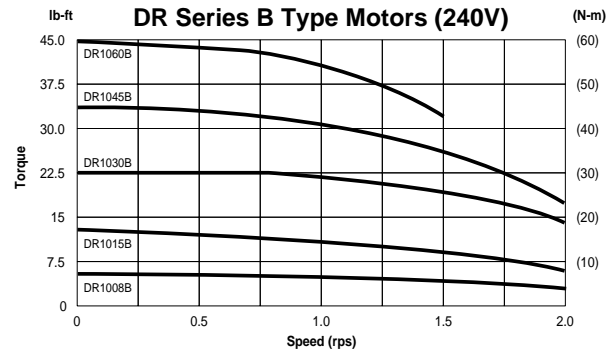
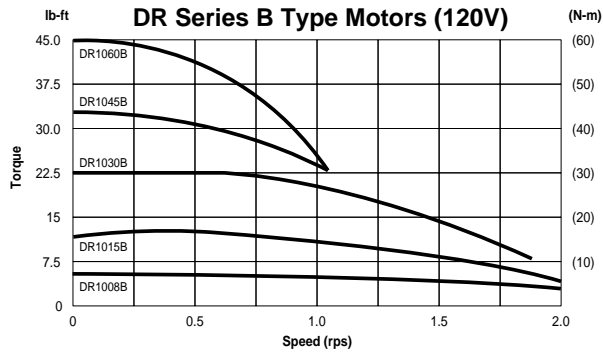
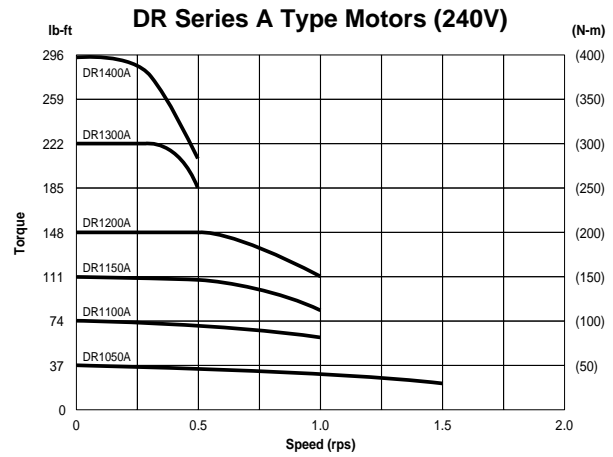
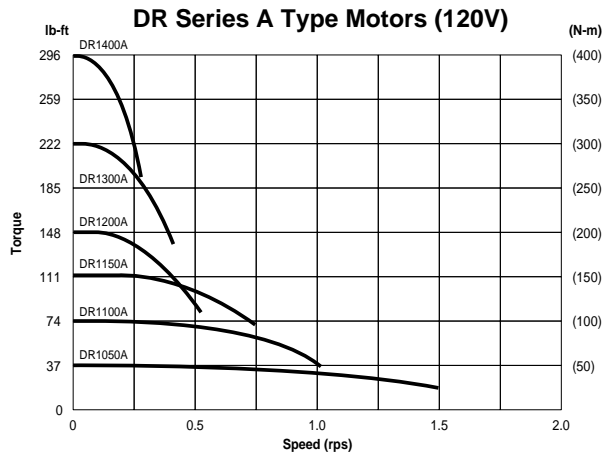

DR Series—Motor Data

		Model 1008B	Model 1015B	Model 1030B	Model 1045B	Model 1060B	Model 1070E	Model 1100E	Model 1130E	Model 1160E
Peak torque	ft-lbs	6	11	22	33	44	52	74	96	118
	(Nm)	(8)	(15)	(30)	(45)	(60)	(70)	(100)	(130)	(160)
Rated speed 115/230VAC	rps	2.0/2.0	2.0/2.0	1.5/2.0	1.0/2.0	1.0/1.5	1.5/2.0	1.0/1.5	0.5/1.0	0.5/1.0
Maximum power consumption	KVA	0.4/0.8	0.6/1.2	1.0/2.0	1.0/2.0	1.0/2.0	1.2/2.4	1.3/2.6	1.4/2.8	1.6/3.2
Rotor inertia										
	oz-in ² x 10 ² (kgm ² x 10 ⁻³)	7.9 (15)	11 (21)	13 (24)	14 (26)	18 (33)	46 (85)	55 (100)	68 (125)	77 (140)
Max resolution		507,904	507,904	507,904	507,904	507,904	614,400	614,400	614,400	614,400
Motor weight*	lbs	13	20	24	29	35	49	57	70	79
	(kg)	(6)	(9)	(11)	(13)	(16)	(22)	(26)	(32)	(36)
Maximum axial load**										
	Compression	lbs	6,744	6,744	6,744	6,744	6,744	8,992	8,992	8,992
Tension	lbs	2,248	2,248	2,248	2,248	2,248	4,496	4,496	4,496	4,496
Maximum overhung load **	ft-lb	148	148	148	148	148	295	295	295	295
*Drive weight is 13.2 lbs (6 kgs)										
** For alternating loads, multiply these values by 0.3										
		Model 1100A	Model 1200A	Model 1300A	Model 1400A	Model 5015C	Model 5030B	Model 5070B	Model 5300A	Model 5500A
Peak torque	ft-lbs	74	148	221	295	10.3	22	51	221	370
	(Nm)	(500)	(100)	(300)	(400)	(14)	(14)	(70)	(300)	(500)
Rated speed	rps	1.0/1.0	0.5/1.0	0.25/0.5	0.25/0.5	4	4	4	1.5	1.5
Rotor inertia										
	oz-in ² x 10 ² (kgm ² x 10 ⁻³)	109 (200)	156 (285)	186 (340)	219 (400)	4.38 (8)	14.2 (8)	19.7 (36)	186.0 (340)	251.6 (460)
Resolution	Steps/rev	819,200	819,200	819,200	819,200	212,992	278,528	278,528	425,984	425,984
Motor weight*	lbs	68	101	125	15	15.4	28.9	38.9	122.2	166.7
	(kg)	(31)	(46)	(57)	(68)	(7)	(7)	(17.5)	(55)	(75)
Maximum axial load**										
	Compression	lbs	8,992	8,992	8,992	8,992	1,100	6,600	6,600	8,800
Tension	lbs	4,496	4,496	4,496	4,496	660	2,200	2,200	4,400	4,400
Maximum overhung load**	ft-lb	295	295	295	295	15	148	148	296	296
Maximum power consumption	KVA	1.4/2.9	1.7/3.5	1.8/3.7	1.8/3.7	—	3.6	3.6	5.5	7.5
*Drive weight is 24lbs (11kgs)						*Drive weight is 13.2 lbs (6 kgs)				
**For alternating loads, multiply these values by 0.3						** For alternating loads, multiply these values by 0.3				

DM Series Motor Performance

		Model 1015B	Model 1030B	Model 1045B	Model 1050A	Model 1100A	Model 1150A	Model 1200A
Peak torque (Nm)	ft-lbs (8)	11 (15)	22 (30)	33 (45)	37 (50)	74 (100)	111 (150)	148 (200)
Rated speed rps	115VAC 230VAC	2.0 2.0	2.0 2.0	1.0 2.0	1.0 1.0	1.0 1.0	0.5 1.0	0.5 1.0
Power Consumption load Max 115/230VAC	KVA	0.9/1.8	1.2/2.3	1.2/2.3	1.4/2.8	1.6/3.1	1.7/3.5	1.7/3.5
Rotor inertia	oz-in ² x 10 ² (kgm ² x 10 ⁻³)	6.6 (12)	8.2 (15)	10.4 (19)	52.5 (96)	65.1 (119)	77.6 (142)	91.3 (167)
Max resolution	lbs	655,360	655,360	655,360	1,024,000	1,024,000	1,024,000	
Motor weight*	lbs (kg)	12 (5.5)	17 (7.5)	21 (9.5)	32 (14.5)	42 (19)	53 (24)	64 (29)
Maximum axial load**								
Compression	lbs	6,600	6,600	6,600	8,800	8,800	8,800	8,800
Tension	lbs	2,200	2,200	2,200	4,400	4,400	4,400	4,400
Maximum overhung load**	ft-lb	148	148	148	296	296	296	296

*Drive weight is 13.2

**For alternating loads, multiply these values by 0.3

DM Series Motor Performance

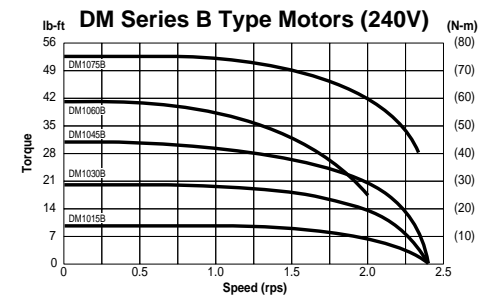
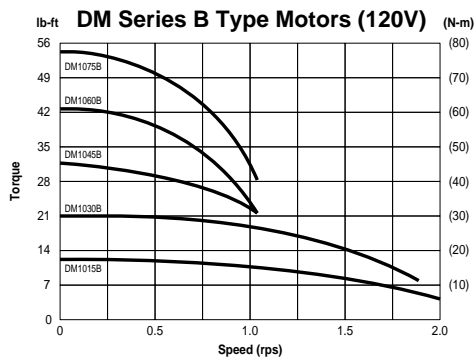
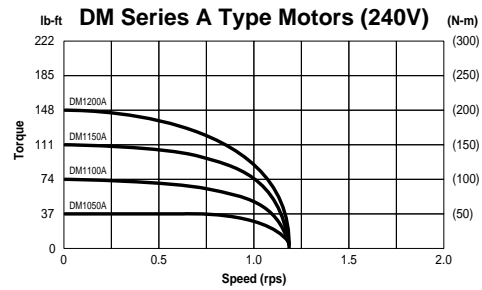
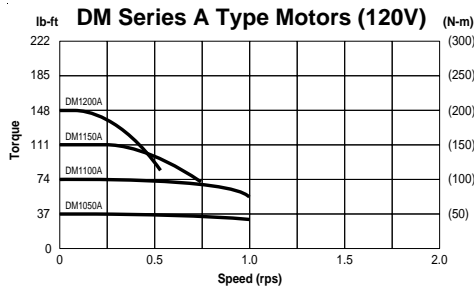

Dimensional Specifications

This section contains dimensional specifications of Dynaserv motors. The dimensions are presented in millimeters (mm).

Motor Dimensions (Types A and E)

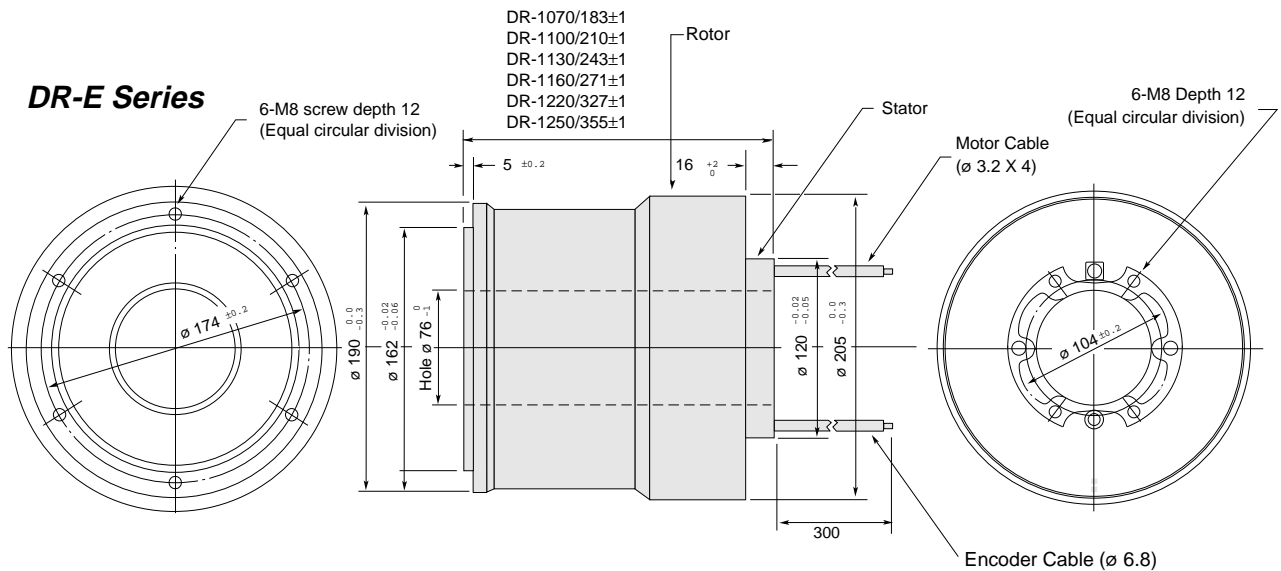
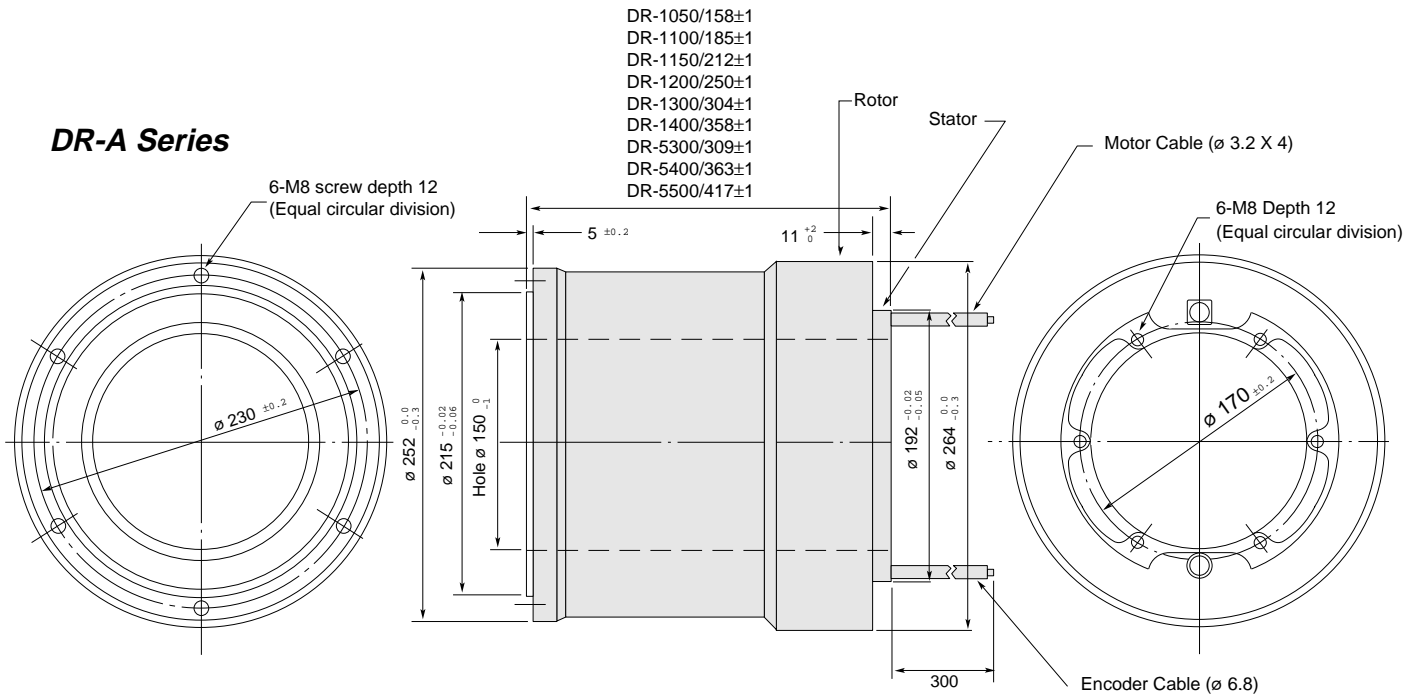

DR-B Series

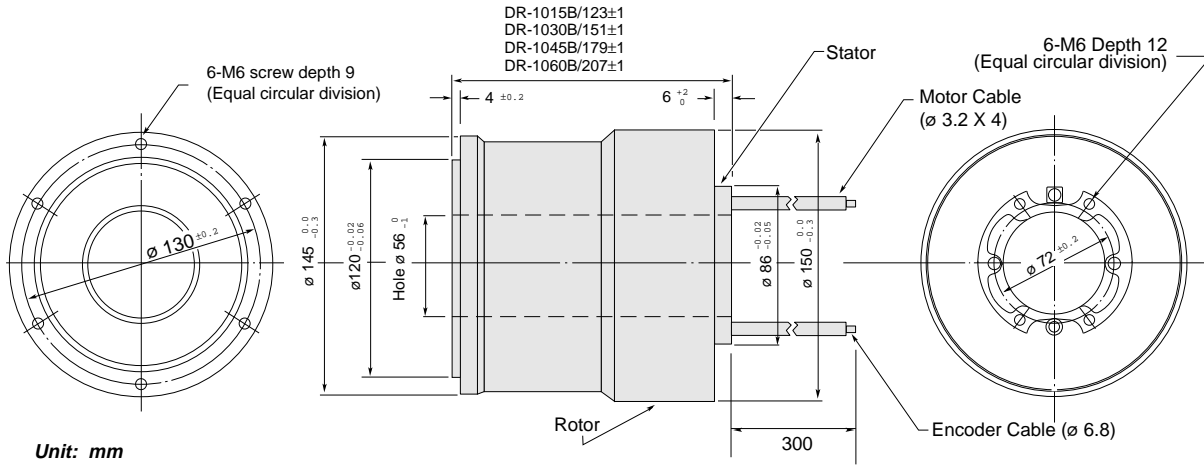

DR-B Series (for the DR1008B only)

DR-B Series (for the DR1008B only)

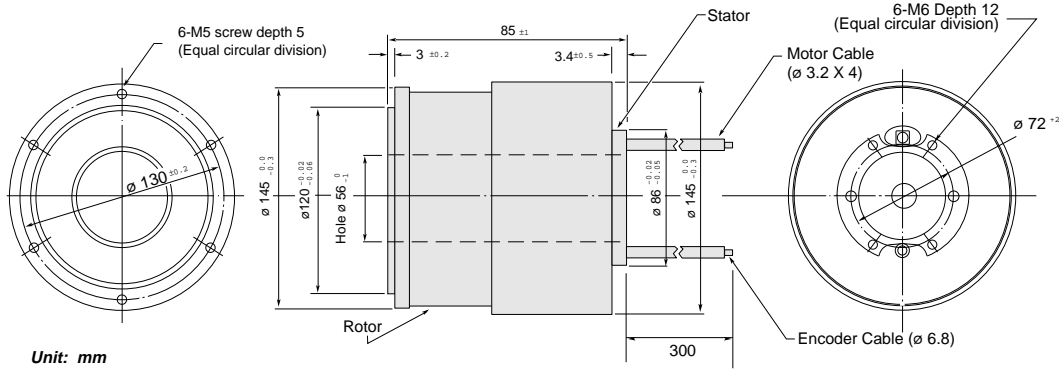

DRC Series

DRC Series

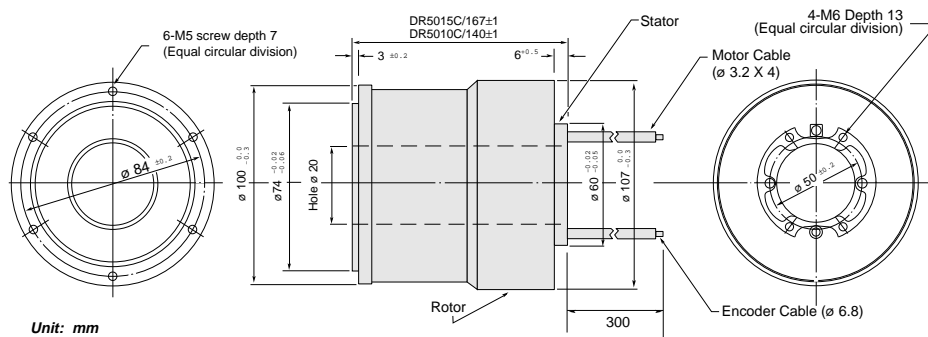

DM Series: Type A Motor

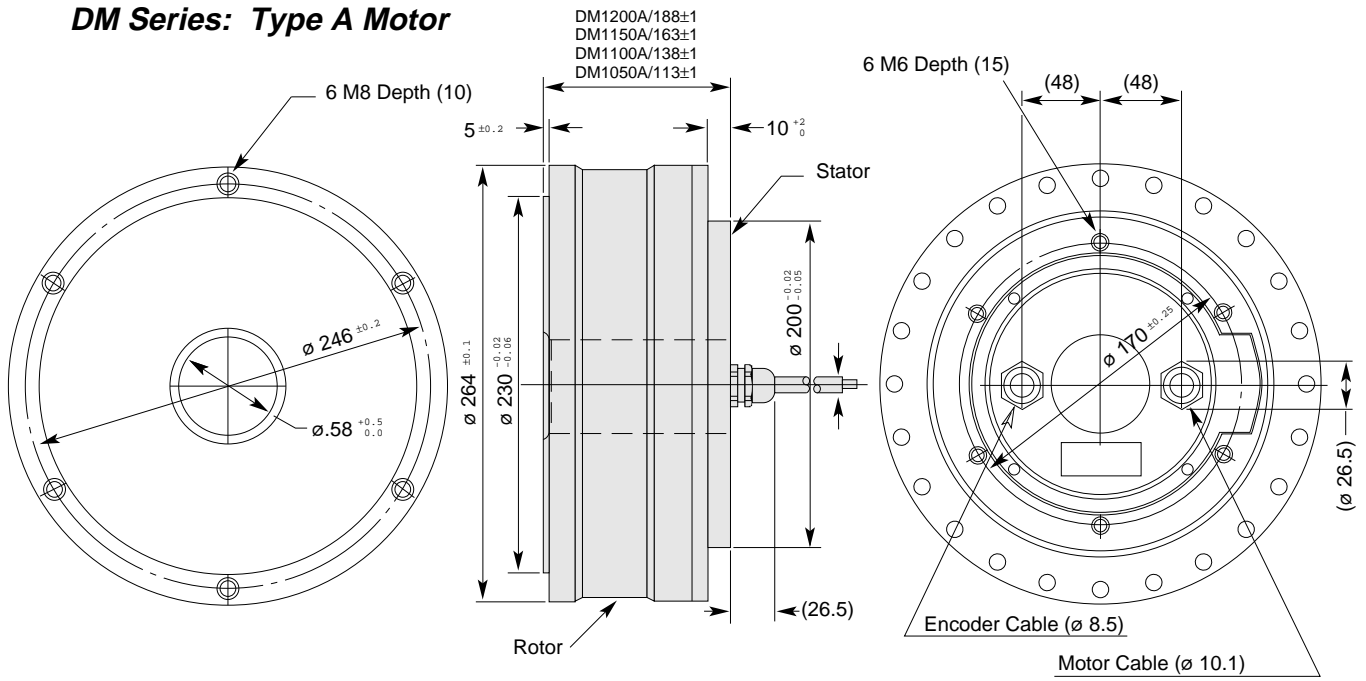

DM Series: Type B Motor

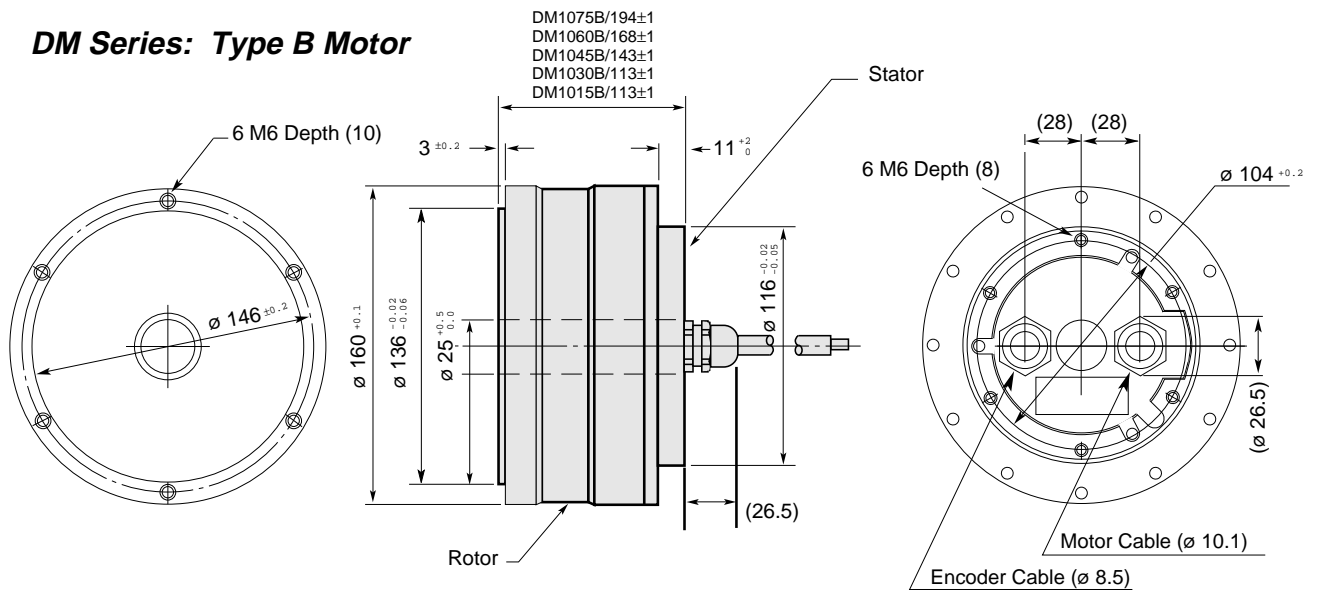

Unit: mm

I/O Signals Between Motor and Driver

TB1 Connection Signal

Signal Name	Meaning
LINE (MN)	AC input for motor/drive power
115VAC or 230VAC	AC input for motor/drive power
LINE (CONT)	AC input for control circuit power
115VAC or 230VAC	AC input for control circuit power
GND	Frame ground

TB2 Connection Signal

Signal Name	Meaning
LINE (MN)	AC input for motor/drive power
115VAC or 230VAC	AC input for motor/drive power
LINE (CONT)	AC input for control circuit power
115VAC or 230VAC	AC input for control circuit power
GND	Frame ground

CN2 Connection Signal (DR Series)

Signal Name	Connector Pin #	Meaning
+S0	1	Excitation Signal Output (Sine phase)
+S180	1	
-S0	2	Detection Signal Input (Sine 0°)
-S180	3	Detection Signal Input (Sine 180°)
SHIELD	4	Shield
FG	5	Frame ground
+C0	6	Excitation Signal Output (Cosine phase)
+C180	6	
-C0	7	Detection Signal Input (Cosine 0°)
-C180	8	Detection Signal Input (Cosine 180°)

CN2 Connection Signal (DM Series)

Signal Name	Connector Pin #	Meaning
+V	1	Encoder Power Supply
GND	2	Above Signal Ground
O Signal	3	Encoder Phase 1 Signal
GND	4	Above Signal Ground
O Signal	5	Encoder Phase 1 Signal
GND	6	Above Signal Ground
ZERO	7	Detection Signal Input (Cosine 0°)
GND	8	Above Signal Ground
CLK+	9	Encoder Sample Clock
CLK-	10	Above Signal Ground
FG	11	Frame ground
	12 - 16	No Connection