

Compumotor

**Dynaserv
DM & DR
Direct Drive Servos
User Guide**

**Compumotor Division
Parker Hannifin Corporation
p/n 88-013940-01 B March 1995**



Important User Information

To ensure that the equipment described in this user guide, as well as all the equipment connected to and used with it, operates satisfactorily and safely, all applicable local and national codes that apply to installing and operating the equipment must be followed. Since codes can vary geographically and can change with time, it is the user's responsibility to identify and comply with the applicable standards and codes. **WARNING:** *Failure to comply with applicable codes and standards can result in damage to equipment and/or serious injury to personnel.*

Personnel who are to install and operate the equipment should study this user guide and all referenced documentation prior to installation and/or operation of the equipment.

In no event will the provider of the equipment be liable for any incidental, consequential, or special damages of any kind or nature whatsoever, including but not limited to lost profits arising from or in any way connected with the use of this user guide or the equipment.

**© Compumotor Division of Parker Hannifin Corporation, 1993, 1994
— All Rights Reserved —**

The information in this user guide, including any apparatus, methods, techniques, and concepts described herein, are the proprietary property of Parker Compumotor or its licensors, and may not be copied, disclosed, or used for any purpose not expressly authorized by the owner thereof.

Since Parker Compumotor constantly strives to improve all of its products, we reserve the right to change this user guide and equipment mentioned therein at any time without notice.

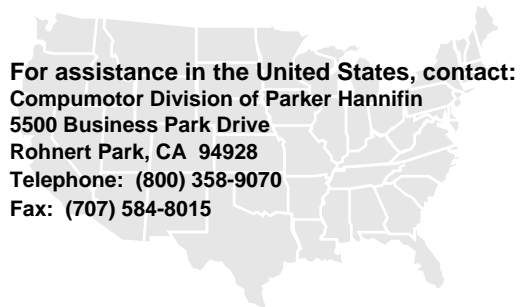

Motion & Control

CHANGE SUMMARY

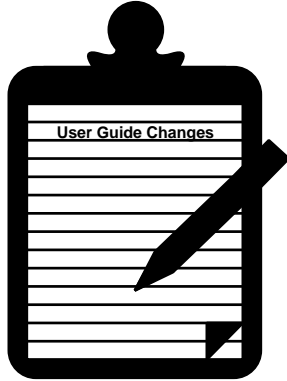

The original version of this user guide was designed by Yokogawa Precision Corporation in Japan. ***This user guide has been completely revised.*** This user guide, version 88-013940-01B, supersedes version 88-013940-01A.

Much of the information from the original user guide has been incorporated in this document. All instructions, procedures, graphics, and technical tables have been written, drawn and tested by Parker Hannifin Corporation's Compumotor Division in Rohnert Park, CA (USA). The text has been reorganized, and edited for clarity and all graphics have been redrawn to better support steps and procedures provided in the user guide.

Installation and Operation Precautions

1. Never install the motor with the rotor fixed and the stator set free for rotation.
2. Ensure that the power is switched off when removing the side panel of the driver for jumper setting, etc. Dangerously high voltage is present inside the unit.
3. The motor rotates at high speed with high torque. Beware of the rotating radius of the load when operating the motor with the load installed.
4. When installing a load to the rotor of the motor, allow a space of 1, or more between the top surface of the motor and the surface of the load in order to maintain the proper alignment of the surfaces. Never apply any force or press fit any materials into the center hole. (See the figure below.)
5. Because a magnetic resolver is incorporated in the motor part shown in figure on the right, avoid shock, mechanical pressure, or strong magnetic field.

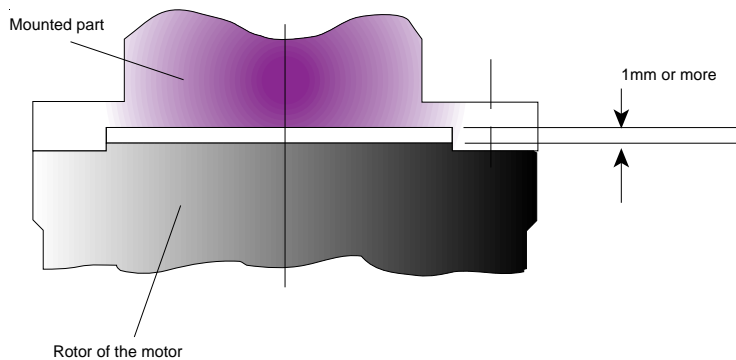

6. Use only such screws which shall not exceed the effective screw depth of the motor part in order to fix the load. The use of long screws may cause damage to the motor.
7. If the motor is used with oscillating rotation movements with a small angle (59° or less), carry out a running-in operation with back-and-forth movement about 10 times, each move exceeding an angle of 90° at least. The running-in operation must be carried out every 10,000 times of back and forth oscillation movement in order to ensure proper lubrication of the bearings.

8. Materials easily affected by magnetism must never be brought close to the motor as the surface of the motor is magnetized.
9. Install the motor in an appropriate location as the motor is not dust proof, watertight, or oil proof.
10. Compatibility of the motor with the driver or vice versa of same model is possible only when they are of the same type. (i.e., When the motor code is DR1□□□60*1 and the driver code is SR1□□□60, the □□□□ of the motor and driver shall be the same.)
11. Never disassemble or modify the motor or the driver. When such disassembling or modification is required, consult Compumotor. Compumotor accepts no responsibility for disassembled or modified motor and driver.

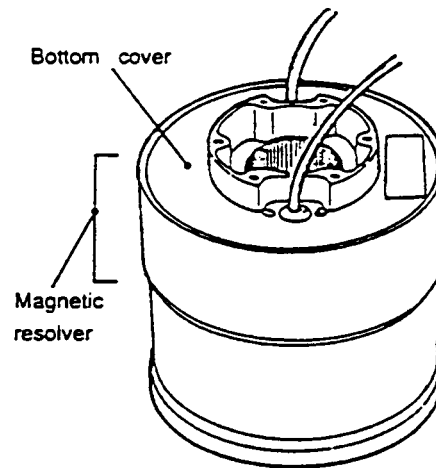

12. With the motors of the Dynaserv DR series, rust prevention coatings are applied to the loadmount part at the top and also to the fixed part at the bottom of the motor. Before assembling the motor, completely remove this coating using a cloth or paper dipped in petroleum solvent or chlorine solvent. The presence of the coating may lead to severe mechanical inaccuracies of the assembled system.

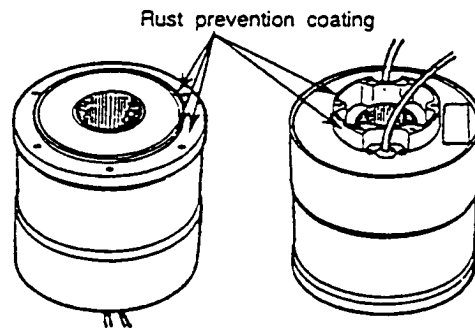

13. If the motor is placed on the floor or a table as shown below when carrying or installing the Dynaserv, the cable is bent by the weight of the motor and this bending may cut the conductor wire. When placing the motor, be sure to use the supporting base which protects the cable from being bent.

The minimum bending radius shall be 50mm or more when installing the motor with the cable being bent. Do not apply bending force repeatedly to the cable when it is used. The cable specifications do not include application with a robot.

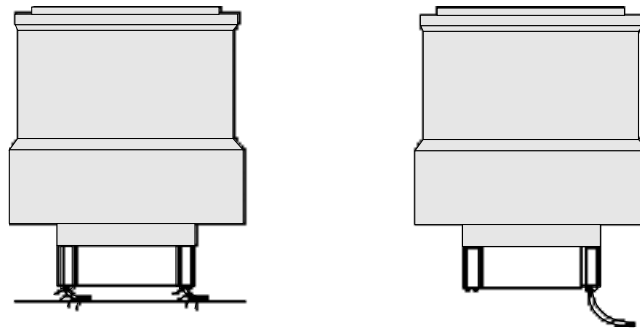

14. Never carry out a withstanding voltage test. Carrying out this test even accidentally may damage the circuits.
15. Appropriate centering and alignment must be carried out when connecting the motor to a load. The shaft metal of the motor may get damaged if the centering offset remains 10 μ m or more.

