



p/n 88-019883-01A

# Dynaserv Drive MII (DrvMII) Controller/Drive

Effective: June 1, 2001

---

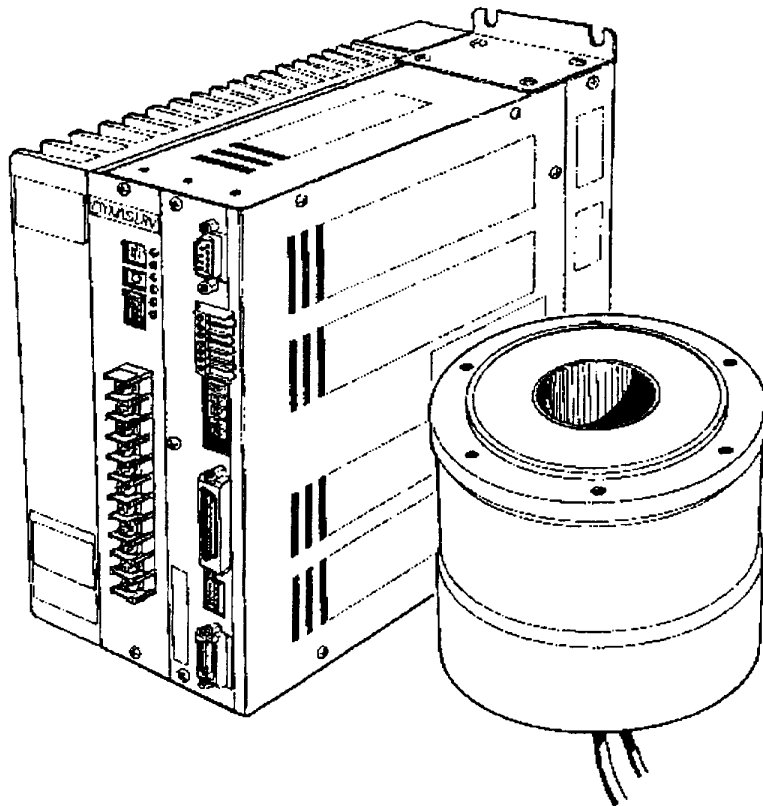

---

## Introduction

Thank you very much for your purchase of the DD servo actuator DYNASERV. The DYNASERV is an outer rotor type servo actuator that has achieved high torque, high speed, and high precision. It can be used in a wide range of applications in the FA device-related fields, such as industrial robotics and indexing.

This instruction manual explains the DYNASERV DM/SR series motors as well as its combinations with the DrvMII drivers. Please refer to this instruction manual thoroughly when you use the product.

### **Precautions for Using this Instruction Manual**

1. Please make sure that this manual is handed out to the end user.
2. Please read this manual thoroughly and understand the contents fully before proceeding to the operation of the product.
3. Please note that the safety protection may be lost and the proper safety may not be guaranteed if the product is not used according to the instructions described in this manual.
4. Always make sure that this manual is handy for the operator when using this product. If it is stained or lost, we will distribute copies upon request, subject to charge.
5. This manual explains details of the features included in the product and does not guarantee to meet the specific purpose of the customers.
6. No part of this manual may be reprinted or reproduced in any form without permission.
7. The information in this document is subject to change without notice.
8. The information contained in this document is believed to be accurate at the time of publication, but if you notice any inaccuracies, errors, or omissions, please contact our sales or service staff.

## Regarding the safe usage of this device

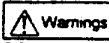
- This product has been marked with  and  signs so that it can be used safely. Ignoring precautions and prohibitions related to these signs and using this product in an incorrect way may cause danger to the life and body of the operator. Always follow the precautions and observe the prohibitions explained below.
- Please make sure to understand the information given below completely before you start reading the technical manual.
- Please keep the technical manual and this sheet handy while using the product. In addition, make sure that they are handed out to the operator of the product.

### Warnings

#### ● **Warning about rotation:**

The motor periphery part of this device rotates at a high speed. People and objects should not be placed within the rotational radius when a load is attached to the motor.

#### ● **Warning about electric shock:**

Make sure to connect the device to ground to avoid electric shock.

Make sure to turn the power off when connecting cables to the driver part.

Make sure to turn the power off when removing the cover of the driver part while performing adjustment operations, etc.

#### ● **Fire and electric shock warning:**

If any abnormalities such as abnormal noise, bad smell, or release of fumes that coming from the device are detected while it is in operation, turn the power off immediately, pull out the power supply plug, and contact us. If the device is dropped or given a strong impact, stop the operation immediately, turn the power off, and contact us.

Do not operate at power supply voltages other than the one indicated on the device.



#### ● **Fire and electric shock warning:**

Avoid dropping or inserting metal shards or combustible materials, or allowing water to get into the opening parts of the device (e.g., the clearance between the rotor and stator of the motor part, or the air vent of the driver part).

In such an eventuality, turn the power off immediately and contact us.

The cables coming out from the motor part or the bottom of the index part should not be forcibly bent, twisted, pulled, heated, or placed under a heavy object.

Never try to remodel or repair the device by yourself.

- This product has been marked with  and  signs so that it can be used safely. Ignoring precautions and prohibitions related to these signs and using this product in an incorrect way may cause danger to the life and body of the operator. Always follow the precautions and observe the prohibitions explained below.
- Please make sure to understand the information given below completely before you start reading the technical manual.
- Please keep the technical manual and this sheet handy while using the product. In addition, make sure that they are handed out to the operator of the product.

## Precautions

- Make sure to read the technical manual before using the device.  
Operational mistakes and faulty wiring may result in damages and failure of the device.
- Make sure to check the wiring once more before turning the power on.  
Faulty wiring may result in fire, electric shock, or damage of the device.
- Confirm that the proper combination of motor and driver parts is used. Using the device with an incorrect configuration may result in failure. (Be sure to confirm the model--MODEL--on the rating nameplates.)
- Make sure the conditions of temperature, humidity, dust, etc. are as specified for the installation and storage environments.
- Do not block the air vent of the device. Keep the specified open space around the device as well. Poor ventilation may cause overheating, leading to failure.
- Some of the motor parts are very heavy; please pay sufficient attention to this when carrying and installing the parts. If the weight is more than 10kg (22.04 lbs), carrying or lifting tools should be used as much as possible.
- Both the motor and driver parts should be installed in the specified orientation.
- Keep the protection cover (transparent plastic plate) attached on the power supply terminal part of the driver. It is provided to prevent inadvertent electric shock accidents.

## Handling Precautions

1. Do not install the motor in reverse direction in such a way that the rotor of the motor is fixed and the stator rotates.
2. Make sure to turn the power off before removing the side panel of the driver to set jumpers, etc. Touching the high voltage part inside the driver is dangerous.
3. This motor rotates at a high speed and with a high torque. Take the rotation radius into consideration and pay special attention to the prevention of any dangerous situations that may occur during the operation when a load is attached to the motor.
4. Make sure to ground the ground terminal to earth.
5. When attached a load to the rotor, make sure to keep a clearance of 1 mm or more between the load and the upper surface of the motor in order to maintain the surface precision. Furthermore, never push or squeeze an object into the shaft hole. (See the figure below.)

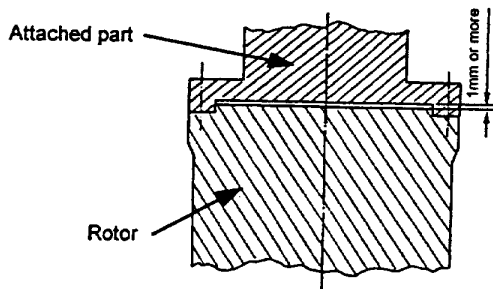

When feeding an object through the shaft hole, make sure to secure a clearance of at least 1mm on one side.

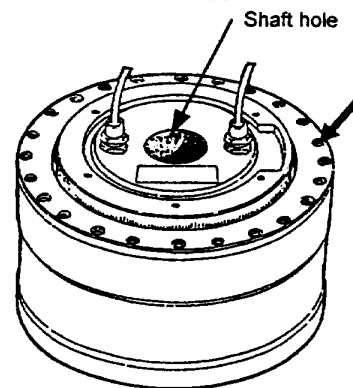

DM series motor

6. Do not touch the bolts (indicated by the arrow) that fix the bottom part of the rotor (see the figure to the right). If these bolts are loosened or tightened, the commutation angle will become inaccurate, which may result in uneven rotation (this applies only to the DM series).
7. The motor surface is magnetized; do not place things that can be affected by magnetism close to it.
8. The motor part shown in the figure to the right includes a magnetic resolver. Strong force, impacts, or magnetic fields should not be applied to the motor part (this applies only to the DR series).
9. Make sure to use load attachment screws that are shorter than the effective depth of the thread in the motor part. Depending on the model, if a screw exceeds the effective thread depth, the function may be impaired (this applies only to the DR series).

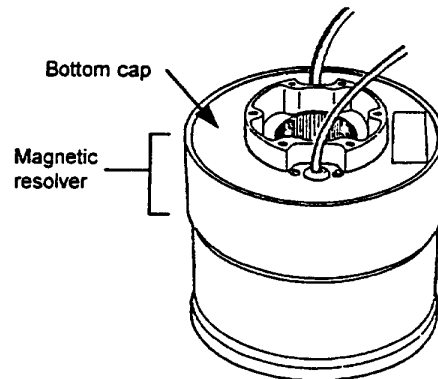

DR series motor

10. The motor is neither dust-, drip- nor water (oil)-proof; the motor should be installed in carefully chosen environments.
11. If the motor will be oscillating or rotating at small angles ( $50^\circ$  or less), it should be allowed to oscillate at an angle of  $90^\circ$  or more for approximately 10 times (running-in operation) each time it has made 10,000 small-angle oscillations in order to prevent poor lubrication of the bearing.
12. In order for the motor and driver to be compatible with each other, they must be of the same model.

13. Never attempt to disassemble or remodel the motor and driver. If such service is necessary, please contact us. We assume no responsibility for products that have been disassembled or remodeled without permission.

14. For the DYNASERV DR series motors, a coating has been applied on the load attachment surface of the upper surface of the motor and the stator on the lower surface in order to prevent rust. When starting to use the product, wipe off the coating completely with cloth or paper soaked in a petroleum or chlorine solvent before assembling. If any of the coating remains, it may affect the mechanical precision.

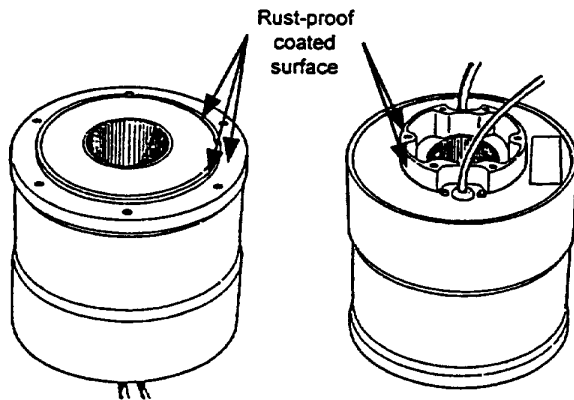

15. Do not place the motor on the floor and other surface in the manner shown in the figure below when carrying and installing the DYNASERV. The cables are crushed by the motor's own weight and the copper wires may be broken inside the cables. If it cannot be avoided to place the motor in such a manner, a support bench should always be placed so that the cables are lifted. Furthermore, if the cables need to be bent when installed in a device, etc., the minimum bending radius should be 50 mm or more. The cables are not strong enough to live up to robot cable specifications, so they should not be bent repeatedly.

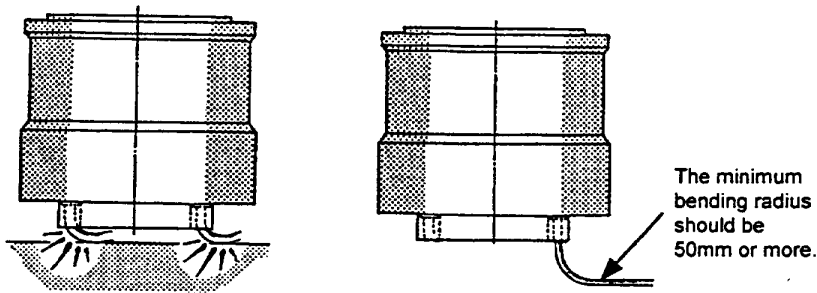

An example of a DM series motor

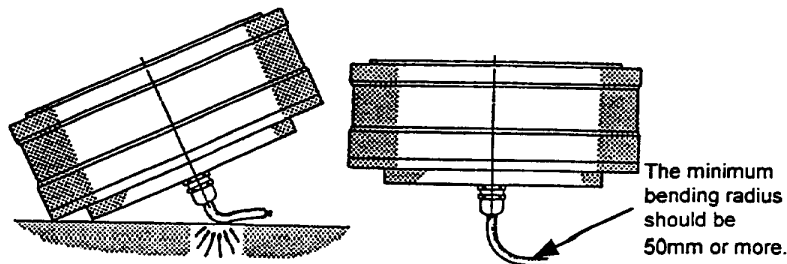

An example of a DM series motor

16. Do not perform a withstanding voltage test on this device. If such a test is performed without discretion, the circuits may be damaged. If such test must be conducted, make sure to contact us.

17. When connecting the motor with a load, the centerlines of both cores should be aligned to a sufficient degree. Please note that if the deviation between the two cores becomes 10  $\mu\text{m}$  or more, the bearings inside the motor may be damaged.

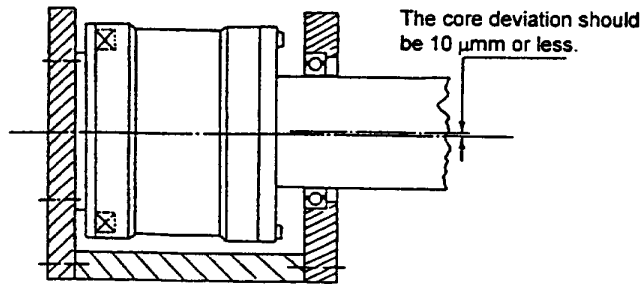

# Table of Contents

Introduction.....	1
<b>Chapter 1 Overview of the Product.....</b>	<b>1-1</b>
1.1 About the DYNASERV DM/DR Series .....	1-2
1.2 About the DrvMII Type Driver.....	1-3
1.3 Installing the PC Utility on the PC .....	1-4
1.4 Model Symbols.....	1-5
1.5 Name and Function of Each Part.....	1-6
1.6 System Configuration Diagram .....	1-10
<b>Chapter 2 Installation.....</b>	<b>2-1</b>
2.1 Installation of the Motor .....	2-2
2.2 Installation of the Driver.....	2-3
<b>Chapter 3 Connection and Wiring.....</b>	<b>3-1</b>
3.1 Diagram of Overall Connection.....	3-2
3.2 Cable Specification List.....	3-3
3.3 Connection between Motor and Driver .....	3-4
3.4 Wiring of Motor, AC Power Supply, and Ground Cable.....	3-6
3.5 Wiring of Encoder Cable .....	3-8
3.6 Wiring of Contact I/O (1) Cable .....	3-9
3.7 Wiring of Contact I/O (2) Cable .....	3-10
3.8 Wiring of Sensor Brake Terminal.....	3-11
3.9 Wiring of Regenerative Alarm Contact <CNA> (For 500W Type Drive Only).....	3-12
<b>Chapter 4 Basic Operation (Let's Operate First).....</b>	<b>4-1</b>
4.1 Procedure (Flowchart) .....	4-2
4.2 Preoperation check.....	4-3
4.3 Installing the PC Utility on the PC .....	4-4
4.3.1 Procedure .....	4-4
4.3.2 Startup.....	4-6
4.4 Preparation.....	4-7
4.4.1 Selecting Communication Port .....	4-7
4.4.2 Selecting Channels.....	4-7
4.4.3 Displaying Communication Strings .....	4-8
4.4.4 Main Menu.....	4-9



4.5	Setting the Status to Servo ON .....	4-10
4.6	Auto-tuning.....	4-12
4.7	Performing Homing Operation .....	4-14
4.8	Performing Program Operation .....	4-16
4.8.1	Verifying Operation Conditions .....	4-16
4.8.2	Creating a Sample Program .....	4-17
4.8.3	Starting the Sample Program .....	4-19
<b>Chapter 5</b>	<b>Functions.....</b>	<b>5-1</b>
5.1	Operation Mode .....	5-2
5.2	Parameters and Monitors .....	5-3
5.2.1	General Parameters .....	5-3
5.2.2	Mechanical Setting Parameters.....	5-3
5.2.3	Monitors.....	5-4
5.2.4	Registration Parameters .....	5-4
5.2.5	Volatile Parameters .....	5-4
5.2.6	Points Set (Value and Option).....	5-4
5.3	Operation Functions.....	5-5
5.3.1	Jog Move .....	5-5
5.3.2	Test Operation.....	5-6
5.3.3	Auto-Tuning Operation.....	5-6
5.3.4	Homing Move .....	5-7
5.3.5	Program Operation.....	5-10
5.3.6	Signal Search Move .....	5-11
5.3.7	MDI Operation.....	5-11
5.3.8	Index Type A Operation.....	5-12
5.3.9	Index Type B Operation.....	5-13
5.3.10	Table Reference Operation.....	5-14
5.3.11	Mechanical Setting Mode .....	5-14
5.4	Coordinate System.....	5-15
5.4.1	Scaling Conversion (Conversion from Command Units to Pulse Units).....	5-15
5.4.2	Conversion from Operation Units to Command Units.....	5-16
5.4.3	Rotational Coordinates.....	5-17
5.4.4	Linear Coordinates.....	5-17
5.4.5	Operation Coordinates Unsettled Status .....	5-18
5.5	Acceleration/Deceleration Function .....	5-19
5.5.1	Velocity Override Function.....	5-19
5.5.2	Trapezoidal Motion Profile.....	5-19
5.5.3	Cam Profile Move.....	5-21
5.6	Programming Language.....	5-24
5.6.1	NC Executable Statements.....	5-24
5.6.2	Parameter Statements.....	5-25
5.6.3	Control Parameters.....	5-26
5.6.4	Comment Statements .....	5-27
5.6.5	Explanation of Built-in Programs .....	5-28
5.7	M Function.....	5-30

5.8	Control System .....	5-31
5.8.1	Velocity Control Part .....	5-32
5.8.2	Position Control Part.....	5-33
5.8.3	Feed Forward .....	5-33
5.8.4	Servo Stiffness Parameter .....	5-33
5.9	Other Functions .....	5-34
5.9.1	Settling Wait, Position Settling Status, and Positioning Status .....	5-34
5.9.2	Velocity Monitor and Analog Monitor.....	5-35
5.9.3	Brake Signal.....	5-35
5.9.4	Area Signals.....	5-36
5.10	Special Parameter Processing .....	5-37
5.10.1	Internal Generation of Parameter Initial Values .....	5-37
5.10.2	Limiting and Checking the Maximum Velocity When Changing Scaling Data and Maximum Velocity Parameter.....	5-37
5.10.3	Auto Conversion and Clear Functions When Changing Scaling Data.....	5-38
5.10.4	Limiting the Maximum Parameter Values .....	5-38
Chapter 6	Control Interfaces.....	6-1
6.1	RS232C Interface.....	6-2
6.1.1	Overview.....	6-2
6.1.2	Connection and Setting .....	6-2
6.1.3	Communication Specifications .....	6-4
6.1.4	@ Commands.....	6-6
6.1.5	Parameter Commands .....	6-12
6.2	PLC Interface .....	6-13
6.2.1	Overview.....	6-13
6.2.2	Connection, Setting, and I/O Mapping .....	6-13
6.2.3	Operation 1 .....	6-15
6.2.4	Operation 2 .....	6-23
Chapter 7	DrvMII PC Utility.....	7-1
7.1	Overview.....	7-2
7.1.1	Overview of the Operation Menu .....	7-2
7.1.2	Overview of the Action Menu .....	7-2
7.1.3	Overview of the Data Management Menu .....	7-2
7.2	Installation .....	7-3
7.2.1	Installation under Windows 95/98/98SE/Me/NT4.0/2000.....	7-3
7.2.2	Starting the PC Utility.....	7-5
7.3	Preparation.....	7-6
7.3.1	Selecting a Communication Port.....	7-6
7.3.2	Selecting Channels.....	7-6
7.3.3	Displaying Communication Strings .....	7-7
7.3.4	Main Menu.....	7-8
7.4	Operation Menu .....	7-9
7.4.1	Terminal.....	7-9
7.4.2	Servo Tuning.....	7-14
7.4.3	Oscilloscope.....	7-16

7.5	Action Menu .....	7-19
7.5.1	Homing .....	7-20
7.5.2	Signal Search Move .....	7-22
7.5.3	Index Type A Operation .....	7-24
7.5.4	Index Type B Operation .....	7-26
7.5.5	Table Reference Operation .....	7-28
7.5.6	Jog Move .....	7-30
7.6	Data Management Menus .....	7-32
7.6.1	Parameter Manager .....	7-32
7.6.2	Program Manager .....	7-35
7.6.3	Index Menu .....	7-43
7.6.4	Point Set .....	7-52
7.6.5	Parts .....	7-53
7.6.6	I/O Set .....	7-59
<b>Chapter 8</b>	<b>Operation Display Pendant .....</b>	<b>8-1</b>
8.1	Overview .....	8-2
8.2	Features and Part Names .....	8-2
8.3	Switching Displays .....	8-3
8.4	Terminal Mode Display .....	8-4
8.5	Parameter Monitor Display .....	8-5
8.6	Parameter Settings Display .....	8-6
8.7	I/O Monitor Display .....	8-7
8.8	Special Command Display .....	8-8
8.9	Program Menu Display .....	8-9
8.9.1	Program Edit Displays .....	8-9
8.9.2	Copying a Program .....	8-13
8.9.3	Deleting a Program .....	8-14
<b>Chapter 9</b>	<b>Maintenance and Inspection .....</b>	<b>9-1</b>
9.1	Maintenance and Inspection of the Motor Part .....	9-2
9.2	Maintenance and Inspection of the Driver Part .....	9-2
9.3	Replacing the Battery for Memory Backup .....	9-2
9.4	Backup and Restore Operations of Driver Memory Contents .....	9-3
9.4.1	Backup Operation .....	9-3
9.4.2	Restore Operation .....	9-4
9.5	Motor Problems and Corrective Actions .....	9-5
<b>Chapter 10</b>	<b>Specifications .....</b>	<b>10-1</b>
10.1	Standard Specifications .....	10-2
10.2	Torque - Speed Characteristics .....	10-9
10.3	External Dimensions (Unit: mm) .....	10-10
10.4	Restrictive Conditions for the Frequency of Repeated Operations (DR5000B Series Only) .....	10-14

# Chapter 1

## Overview of the Product

---

- 1.1 About the DYNASERV DM/DR Series
- 1.2 About the DrvMII Type Driver
- 1.3 Installing the PC Utility on the PC
- 1.4 Model Symbols
- 1.5 Name and Function of Each Part
- 1.6 System Configuration Diagram

## 1.1 About the DYNASERV DM/DR Series

The DYNASERV servomotor, is a high speed, high torque, and high precision outer rotor type direct drive motor.

The DM series motors are contained in an aluminum chassis and have a built-in optical encoder. There are four models in the A series with output torque of 50 to 200N·m and five models in the B series with torque of 15 to 75N·m. The outside diameters are 264 mm for the A series and 160 mm for the B series. Each has a shaft hole of 58 mm and 25 mm in diameter at the center, respectively.

The outer shapes of the small-diameter and flat type DM series motors have successfully been made flatter and smaller in diameter based on the basic performance of the conventional DM/SD series. An outer diameter of 116 mm and a height (thickness) of 45 mm, respectively, are achieved for the DM small-diameter type and the DM flat type.

Both types are equipped with an optical encoder, which is characteristic of the DM series, and have the added features of high resolution and high mechanical precision. They are actuators with excellent output-to-space ratios and the best available option for servos for semi-conductor manufacturing devices, precision test devices, etc. They can be used in various applications.

The DYNASERV DR series is a series of operational direct drive motors that was developed based on the field-proven DM series to satisfy new demands. There are six A type models (50 to 400N·m) with an outer diameter of 264 mm (10 inches), seven E type models (30 to 250N·m) with an outer diameter of 205 mm (8 inches), and five B type models (8 to 60N·m) with an outer diameter of 150 mm (6 inches). In addition, there is a 5000B/E type (consisting of five high-speed type models).

Moreover, in addition to the above standard models, several special type models are also available, such as lightweight types, types with flanges, types with brakes and high mechanical precision installation surface types.

---

## 1.2 About the DrvMII Type Driver

The DrvMII type driver is a multipurpose driver with a built-in controller developed as the successor to the conventional M type driver. Not only have the functions been improved, but also the driver box volume has been made smaller, and it can support the DYNASERV rotation type motors, as well as the LINEARSERV series motors that are of the direct drive type.

The features include the following:

- (1) In addition to the contact I/O, <DeviceNet>, <CC-Link>, and <ProfiBus> can be selected as interfaces from the field bus. Also, <CANopen> is under development.
- (2) With the built-in controller function, the size of the driver is reduced to approximately half of the previous size (comparison within our company).
- (3) The resolution is increased by a factor of four for the DM series and a factor of two for the DR series.
- (4) It can now support most of the models of the DYNASERV and LINEARSERV series.
- (5) A sophisticated utility is now available and an oscilloscope function has been included as well.

## 1.3 Installing the PC Utility on the PC

### Components of the Standard Product

The standard set of this product is comprised of the following parts. Please check that the type of product is correct, whether or not all the standard accessories are included, and also the quantity supplied.

Part name	Number	Notes
Main body	Motor part	1 The shape varies depending on the type.
	Driver part	1 The shape varies depending on the type.
Standard accessory	Connector for driver CN2	1 Made by Honda Tsushin Kogyo (connector) PCR-S20FS (cover) PCR-LS20LA1
	Connector for driver CN4	1 Made by Honda Tsushin Kogyo (connector) PCR-S50FS (cover) PCR-LS50LA
	Connector for driver CN5*	1 Made by Phoenix Contact MC1, 5/6-ST-3, 81
	Terminal for driver CNA**	1 Made by Phoenix Contact MC1, 5/2-ST-5, 08

\* Supplied for drivers whose interface type is the I/O contact type.

\*\* Supplied only for 500W type drivers with regenerative terminals

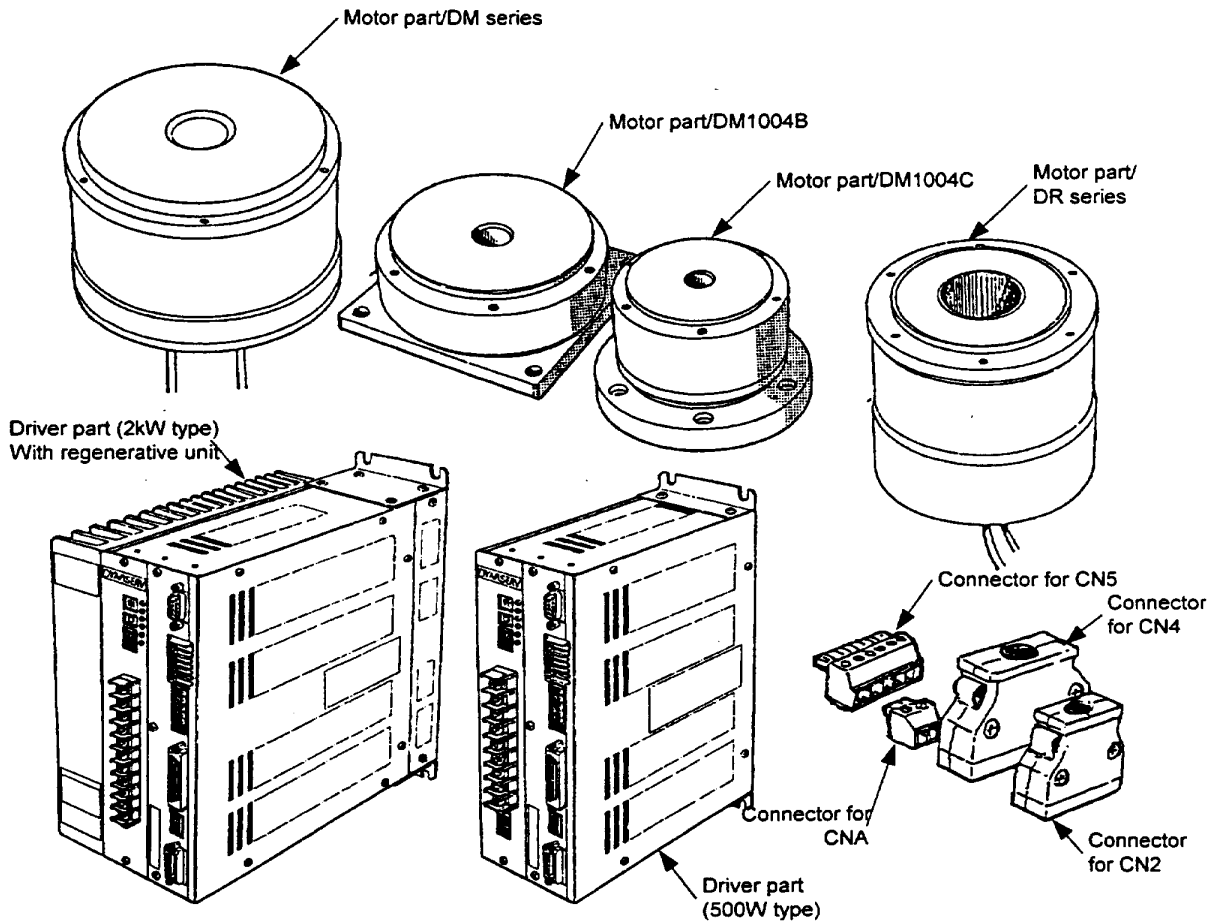

Note: The exact shape varies depending on the model you ordered. Refer to the figure showing the outer dimensions for more details.

## 1.4 Model Symbols

The model symbols for the DYNASERV, motors of DM/DR series, and DrvMII driver are configured in the following manner.

### (1) Motor

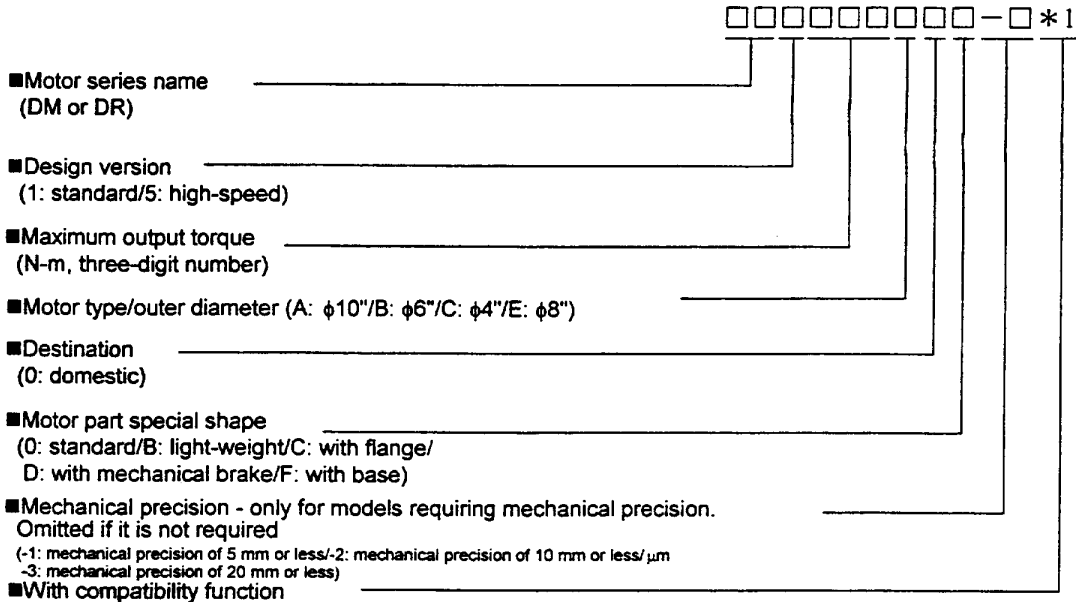

### (2) Driver

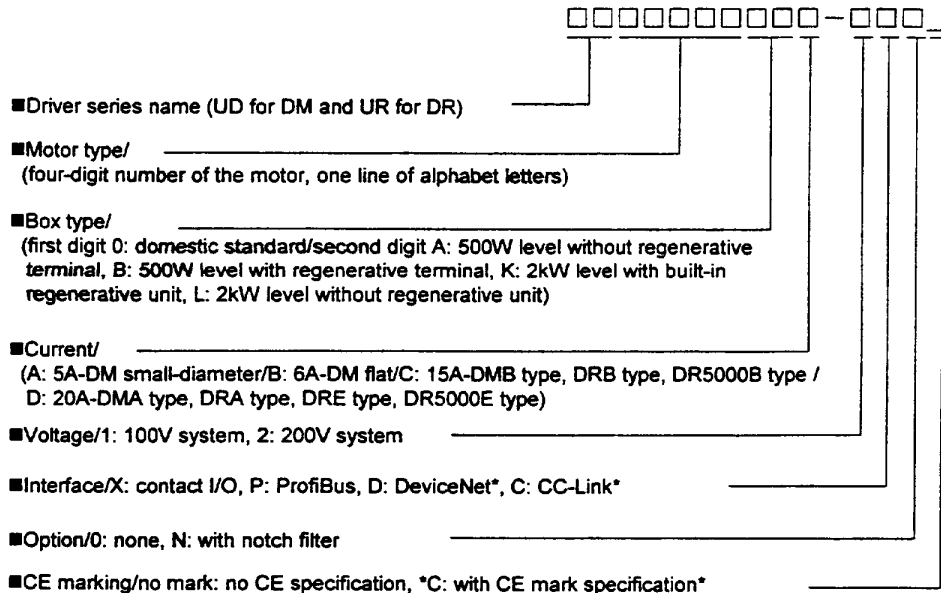

Note: 1. Compatibility between the motor and driver is valid only between the same models.

This means that, for the standard models, the motor and driver are compatible only when the designations of the five digits in motor type (DR□□□□□) and driver type (UR□□□□□) are the same.

2. Separate selection is required for the driver without 2 kW class regenerative unit.

1



# 1 Overview of the Product

## 1.5 Name and Function of Each Part

### (1) Motor Part

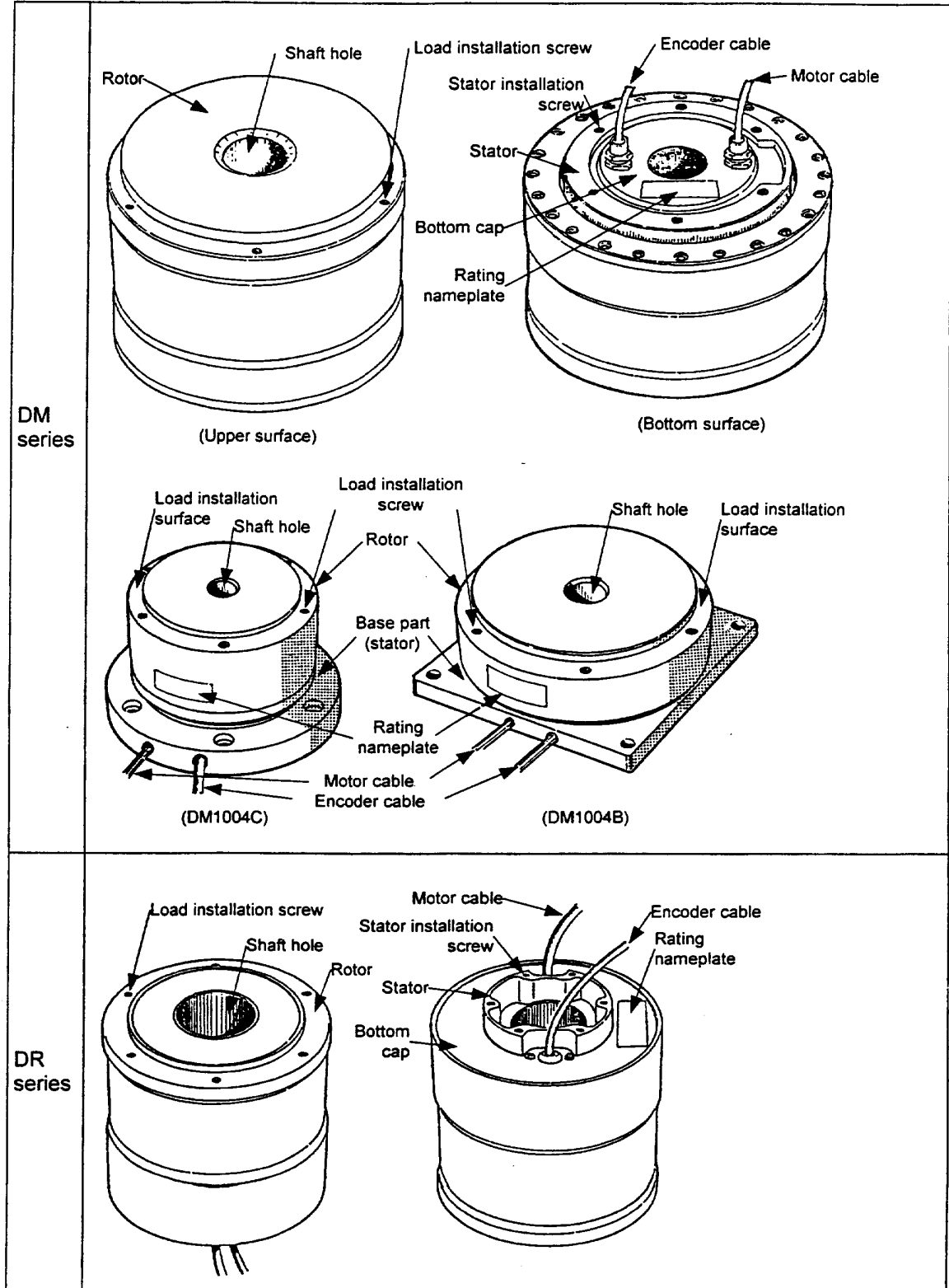

(2) Driver part

■ 500W type

(In case of the DM1004B/1004C models, a model with regenerative terminal is shown)

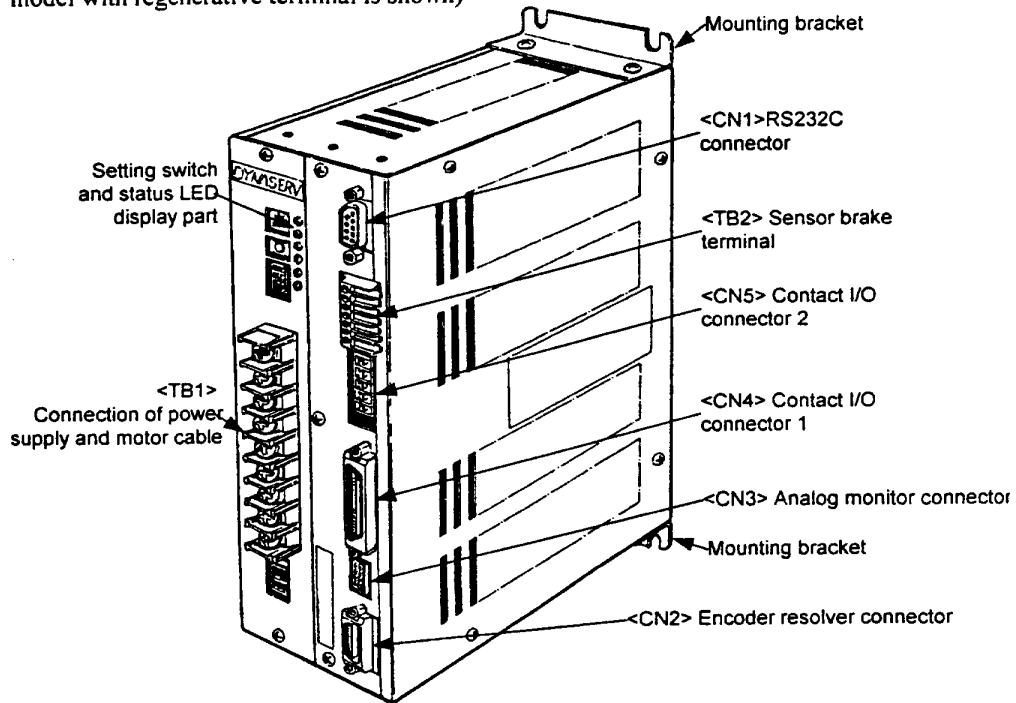

■ 2kW type

(In case of DM series other than the ones mentioned above and DM series, a model with a regenerative terminal is shown)

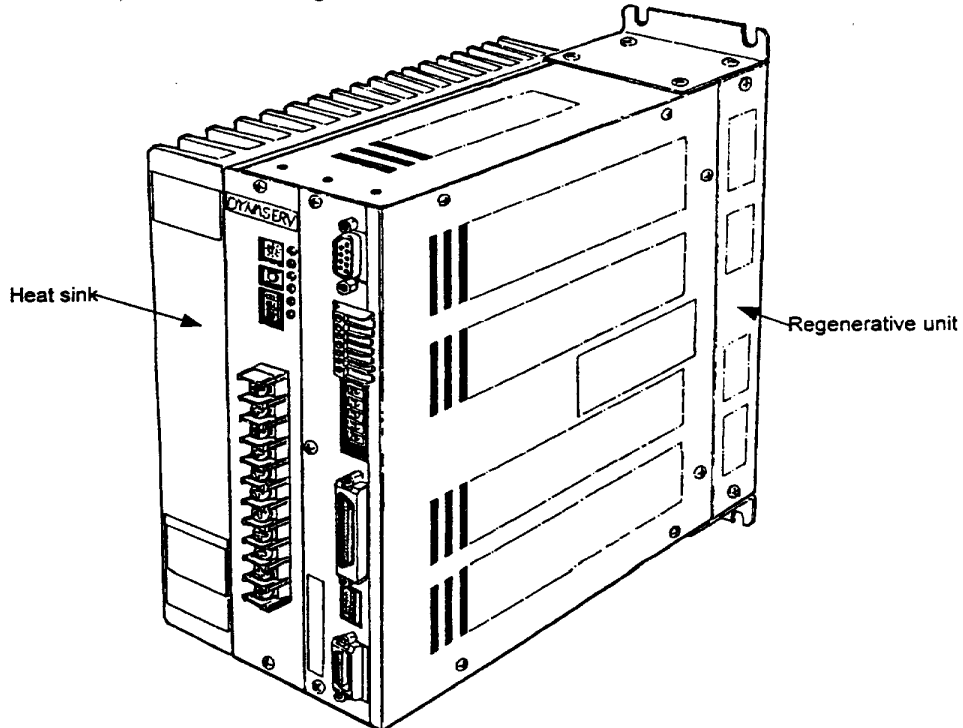

# 1

## Overview of the Product

### (2) Details of the Front Panel of the Driver

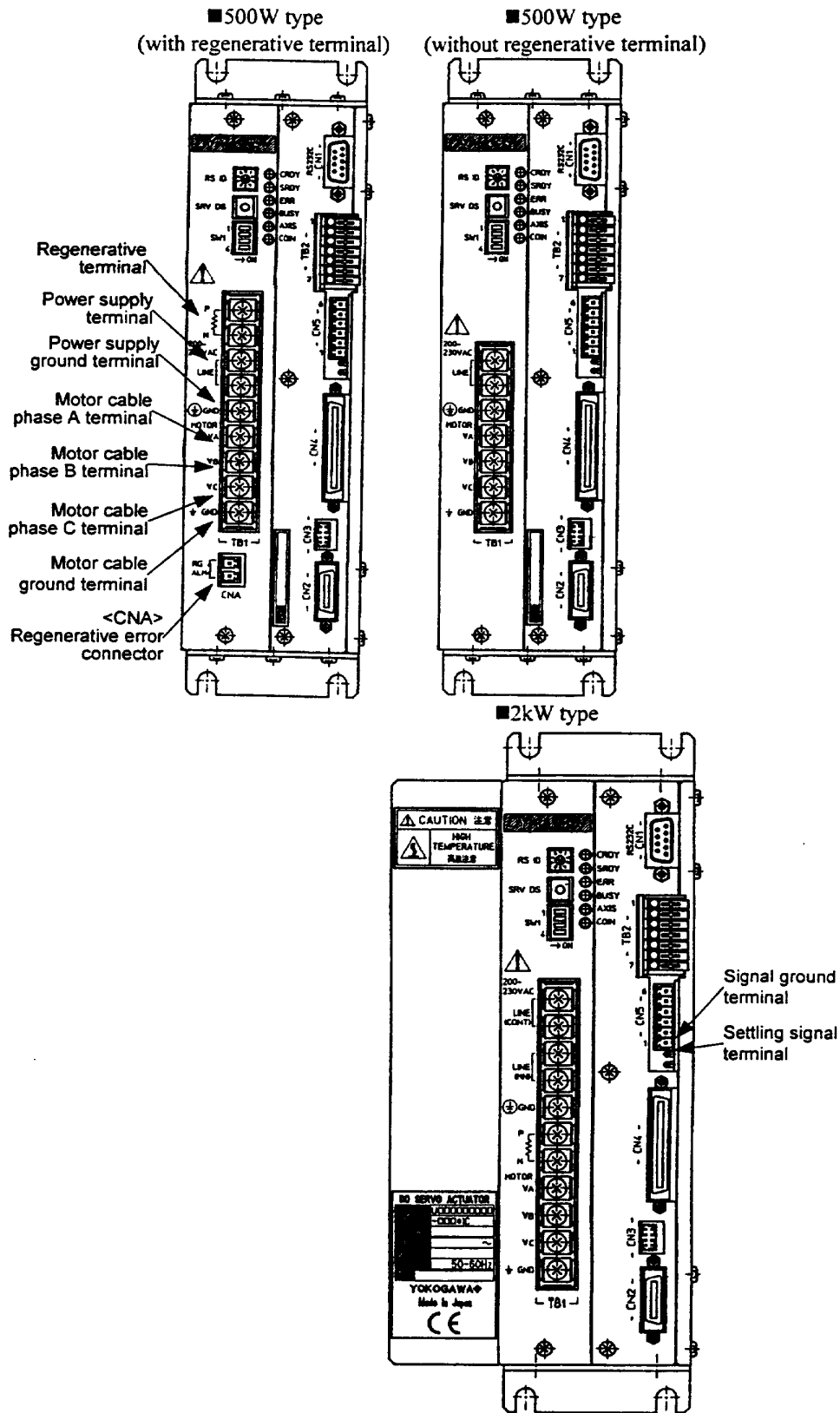

- Note: (1) All the items shown are of the contact I/O type.  
 (2) The power supply ground terminal and the motor cable ground terminal are connected within the driver chassis.

[Details of Setting Switches and Status Display LEDs]

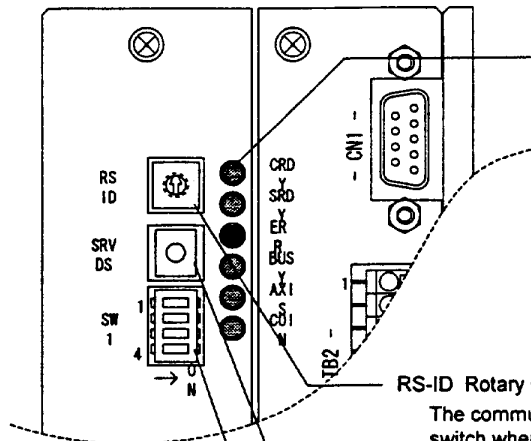

Status display LEDs

CRDY	CPU ready	Indicates that the driver finished its initial processing and went into its normal status.
SRDY	Servo ready	
ERR	Error status	
BUSY	Busy	Indicates that the driver is currently operating.
AXIS	Axis is operating	Indicates that the axis is currently operating (dwell operation)
COIN	Settling status	Indicates that the axis is in its position settling status.

RS-ID Rotary switch

The communication method of the RS232C interface is set according to the status of this switch when the power is turned on.

- 0 Single channel communication
- 1 to 9 Multi-channel communication. The value corresponds to the ID of the slave station.

SRV-DS Servo disable switch

The servo is turned off for as long as this switch is pressed, regardless of the command status of the RS232C interface and PLC interface.

SW1 Slide switch

When the power is turned on, the operation status of the driver is determined by the status of these switches.

Normally, bit4 should be set to off. When bit4 is on, the driver is set in maintenance operation status.

bit1	Reset all	If this bit is on when the power is turned on, all driver information is reset to the default status at shipping.
bit2	Main operation mode setting (PLC main operation mode/RS232C main operation mode)	If this bit is on when the power is turned on, the driver goes into PLC main operation mode. If it is off when the power is turned on, the driver goes into RS232C main operation mode.
bit3	PLC DI emulation setting	If this bit is on when the power is turned on, any input signals from the PLC are ignored and the driver can be operated by the PC utility as if the input signals are transmitted from the PLC. Normally, this bit should be set to off.
bit4	Maintenance operation setting	If this bit is on when the power is turned on, the driver is set in maintenance operation status. Normally, this bit should be set to off.

## 1.6 System Configuration Diagram

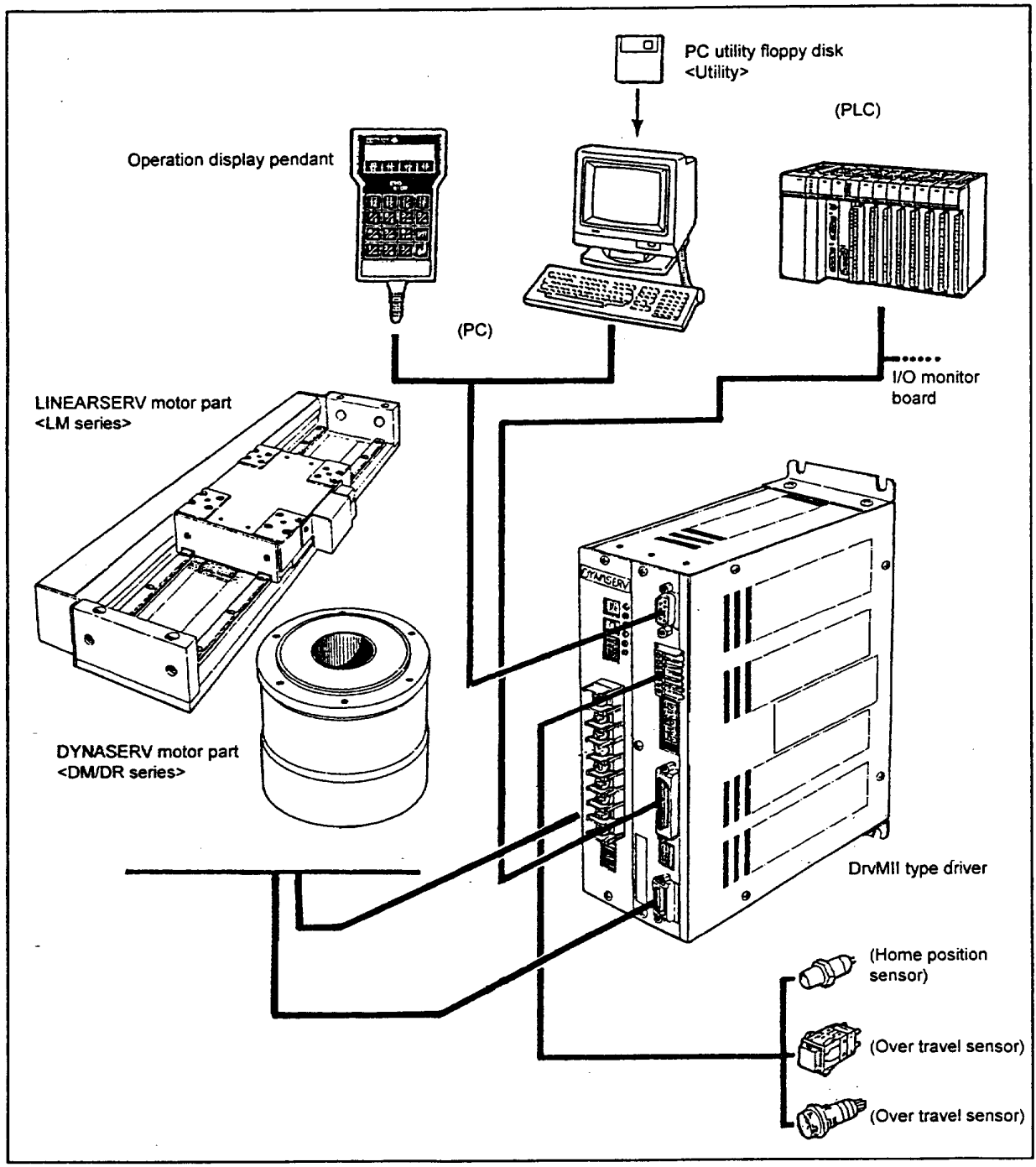

Note: The allowable combinations between the DYNASERV motors and the DrvMII drivers are as follows.

- (1) The 500W type driver can only be used with the DM1004B/1004C.
- (2) All other DM and DR series should be used with the 2kW type driver. Note that they cannot be used with the 500W type driver.

# Chapter 2

## Installation

---

- 2.1 Installation of the Motor
- 2.2 Installation of the Driver

When you receive the product, you should first verify that the model and type of the product are correct, whether all the accessories are included, and that the combination of a motor and a driver is correct before you begin installation and wiring.

## 2.1 Installation of the Motor

The motor part can be installed and used in either a horizontal or a vertical position. However, if installed in a wrong way or position, the life of the motor may be shortened or the motor may fail. Always follow the instructions explained below.

### (1) Installation Position

The motor part is designed based on the assumption that it is used indoors. Therefore, choose the location of installation so that it satisfies the following conditions:

- It should be indoors and not in a place where it can be exposed to corrosive and/or volatile gases.
- The ambient air temperature should be from 0 to 45 °C.
- There should not be too much dust or particles, the ventilation should be good, and the humidity should be low.

Note: The DYNASERV is not drip- or water (oil)-proof. If it is used in such an environment, a proper drip- or water (oil)-proof cover should be applied.

### (2) Mechanical Installation

- When installing a load on the rotor of the motor, make sure to secure a clearance of 1 mm or more between the upper surface of the motor and the installed part in order to maintain the surface accuracy.
- The clamping torque of the screws used to install the rotor and stator of the motor should be equal to or less than the value indicated below.
- The surface flatness where the motor is fixed should be 0.01 mm or less.

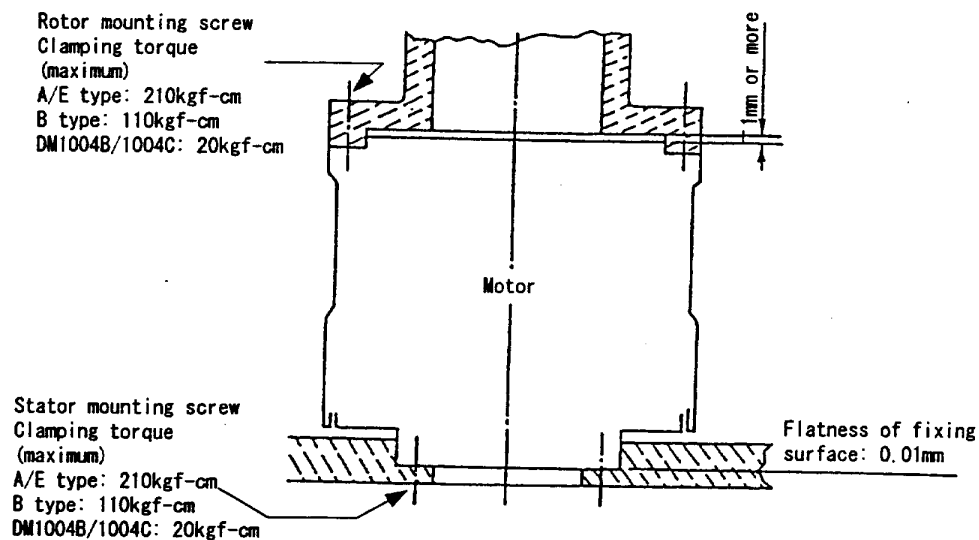

Note: When tightening the screws, make sure to apply a screw lock using Loctite 601 or equivalent product.

## 2.2 Installation of the Driver

The standard installation method for the driver is either to mount it on a rack or a wall.

### (1) Installation Position

- If there is a heating source near by, the temperature should be prevented from increasing by installing a shielding cover, etc.; the temperature around the driver should not exceed 50 °C (Note 1).
- If there is a source of vibration near by, the rack should be installed via a vibration absorption material.
- In addition to the above, it should be avoided to install the driver in surroundings that are high in temperature and humidity, filled with dust, metal powder, corrosive gas, etc.

### (2) Installation Method

- The standard way of installation is to install the driver on a rack, aligning the top and bottom with the front panel in the front. Do not put the panel surface into a sideways position or upside down (see the figure below).
- The driver box employs a natural air ventilation system. Make sure to secure space for ventilation above and below (25 mm or more) and right and left (25 mm or more) (see the figure below).
- Make sure to use the installation holes (four places) of the upper and lower brackets at installation.

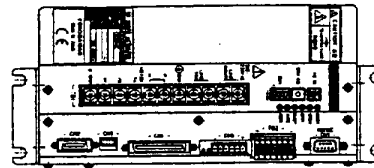
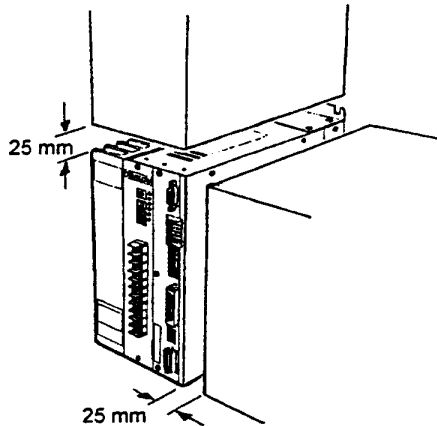

Should not be installed in a sideways position.

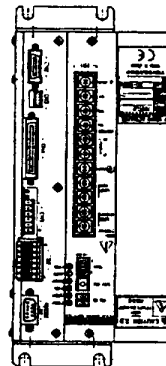

Should not be installed upside down.

2

(Note: 1) 2 kW type drivers, but not other types, will have the current characteristics shown in the graph below as a function of the ambient air temperature during operation. Therefore, it is recommended to use the driver in an ambient air temperature of 40 °C or less in order to prolong its life.

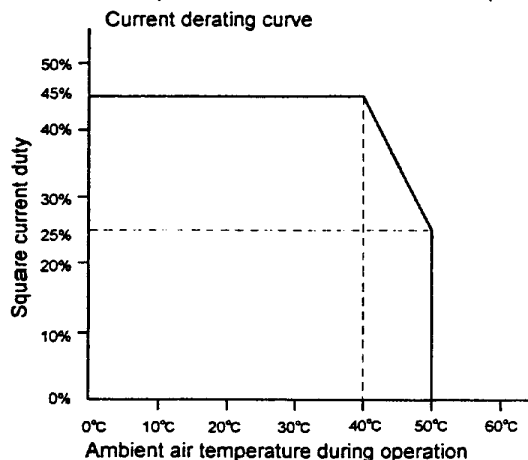





# Chapter 3

## Connection and Wiring

---

- 3.1 Diagram of Overall Connection
- 3.2 Cable Specification List
- 3.3 Connection between Motor and Driver
- 3.4 Wiring of Motor, AC Power Supply, and Ground Cable
- 3.5 Wiring of Encoder Cable
- 3.6 Wiring of Contact I/O (1) Cable
- 3.7 Wiring of Contact I/O (2) Cable
- 3.8 Wiring of Sensor Brake Terminal
- 3.9 Wiring of Regenerative Alarm Contact <CNA>  
(For 500W Type Drive Only)

# 3 Connection and Wiring

## 3.1 Diagram of Overall Connection

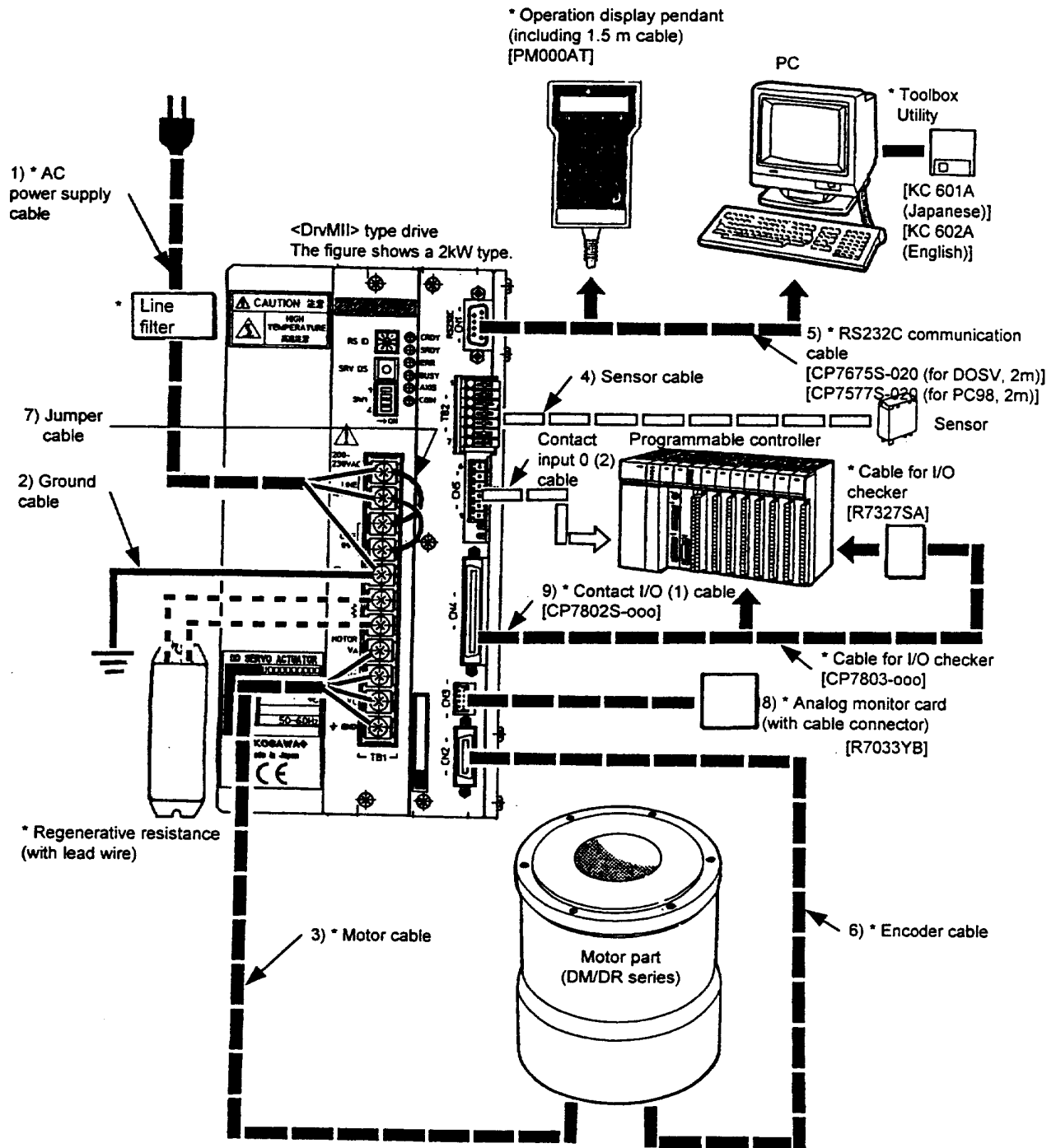

\* Optional parts (see separate wiring section for motor and encoder cables.)

## 3.2 Cable Specification List

	Cable name	Electric cable size	Driver	Current (A)
1)	AC power supply cable	2.0 mm <sup>2</sup> or more, 30 m or less in length	TB1	*
2)	Ground cable (power supply)	2.0 mm <sup>2</sup> or more	TB1	*
3)	Motor cable	2.0 mm <sup>2</sup> or more, 30 m or less in length	TB1	*
4)	Sensor brake cable	0.3 to 0.75 mm <sup>2</sup>	TB2	
5)	RS232C communication cable	Dedicated cable is required.	CN1	
6)	Encoder resolver cable	0.2mm <sup>2</sup> twisted pair, batch shielded cable, outer diameter $\phi$ 14 mm or less, 10 m or less in length	CN2	Maximum 100 mA DC
7)	Jumper cable	2.0 mm <sup>2</sup> or more	TB1	*
8)	Analog monitor card	Dedicated cable is required. [R7033YB] (cable with connector)	CN3	
9)	Contact I/O (1) cable	0.2 to 0.5mm <sup>2</sup> , batch shielded cable, outer diameter $\phi$ 9 mm or less, 3 m or less in length	CN4	Maximum 500 mA DC
10)	Contact I/O (2) cable	0.2 to 1.5 mm <sup>2</sup>	CN5	Maximum 500 mA DC

- \* 20A for the A (10") and E (8") types for both the DM and DR series  
15A for the B (6") type, and 10A for the DM1004B/1004C motors

## 3.3 Connection between Motor and Driver

Note: Shielding should be applied to each wire.

(1) DM Series (DM1004B/1004C) motors

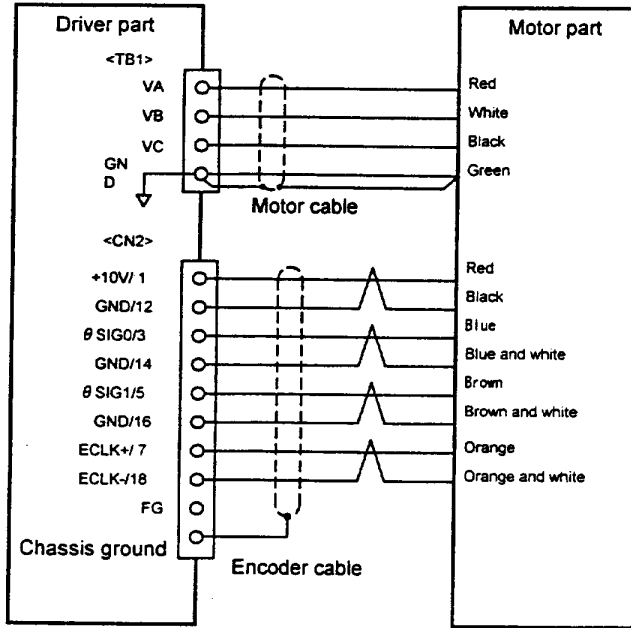

(2) DM Series motors (models other than the above)

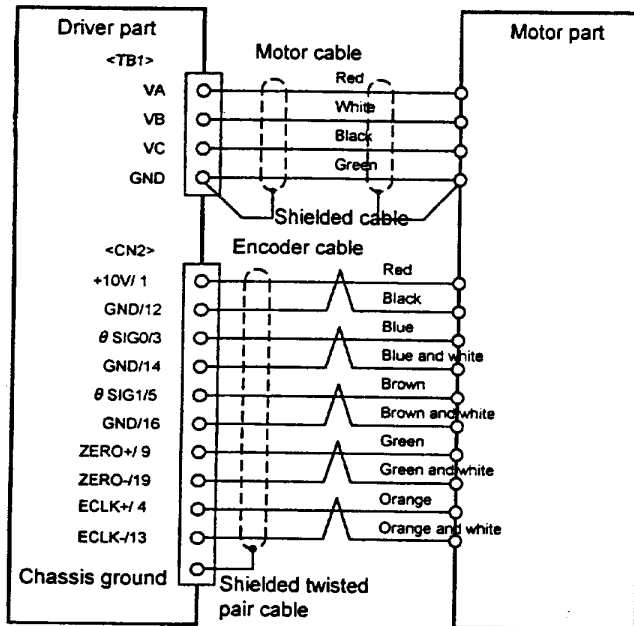

(3) DM Series motors

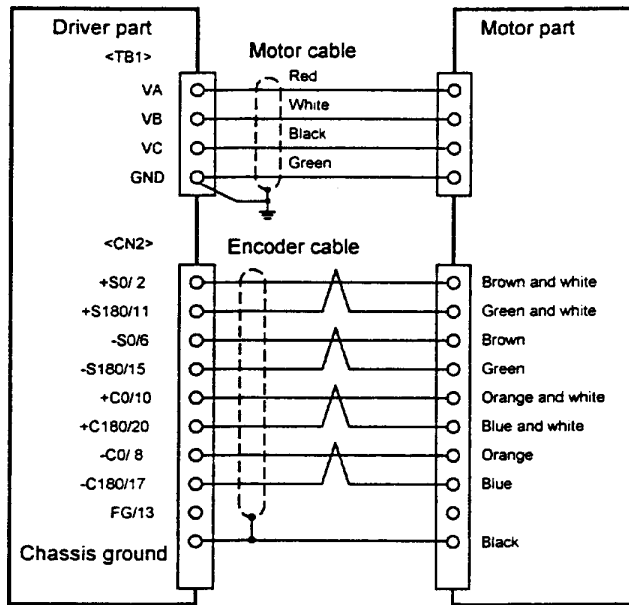

### 3.4 Wiring of Motor, AC Power Supply, and Ground Cable

- (1) For the DM1004B/1004C motors (in connection with a 500W type driver) \* In the case shown, a regenerative resistance is required.

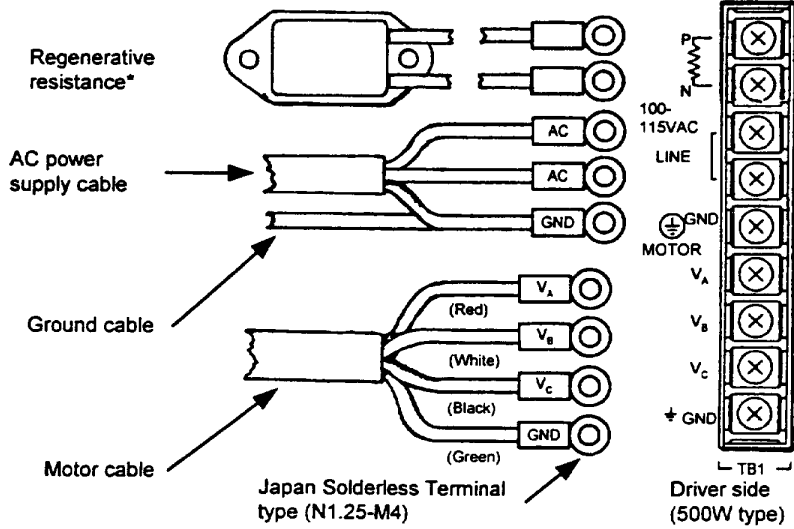

- (2) For other DM/DR series (other than above) (in connection with 2kw type driver)

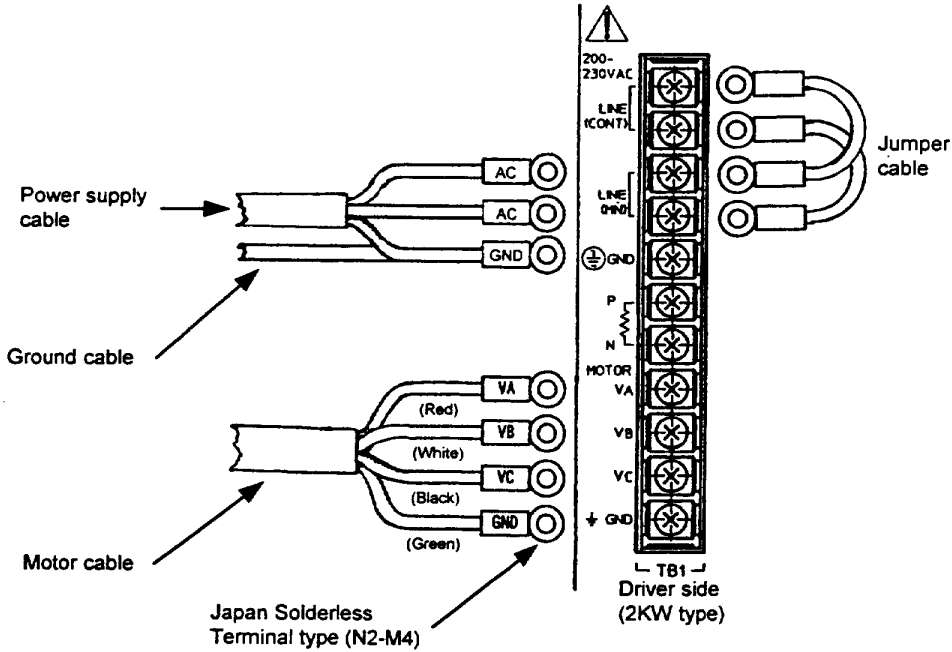

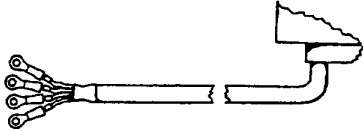
Cable	Specification	
	DM1004B/1004C	Other DM/DR series
AC power supply cable	■ 0.5 mm <sup>2</sup> or more, 30 m or less in length	■ 2.0 mm <sup>2</sup> or more, 30 m or less in length
	■ Clamping torque of terminal: 12[kgf-cm <sup>2</sup> ](1.18[N·m]) (terminal screw: M4x0.7) ■ Power supply filter, recommended part: Tokin Corporation #LF-200 series	
Motor cable	■ 0.5 mm <sup>2</sup> or more, 15 m or less in length	■ 2.0 mm <sup>2</sup> or more, 30 m or less in length
	■ Optional cable: CM6000C-□□□	■ Optional cable: CM300M-□□□ or CM0300R-□□□
		
Ground cable	■ 0.5 mm <sup>2</sup> or more (use as thick cable as possible)	■ 2.0 mm <sup>2</sup> or more (use as thick cable as possible)
	■ Third grade ground (ground resistance 100Ω or less)	
Jumper wire		■ 2.0 mm <sup>2</sup> or more
Regenerative resistance*	For 100V: 80W 60Ω	
	For 200V: 80W 200Ω	

\* Only for models with regenerative resistance (500W type)



3.5 Wiring of Encoder Cable

(1) DM1004B/C motor

Pin #	Signal name	Pin #	Signal name
1	+ 10 V	11	-
2	-	12	GND
3	θSIG 0	13	-
4	-	14	GND
5	θSIG 1	15	-
6	-	16	GND
7	ECLK+	17	-
8	-	18	ECLK-
9	-	19	-
10	-	20	-

Chassis ground	Shielded cable
----------------	----------------

(2) DM series motor (other than the one described to the left)

Pin #	Signal name	Pin #	Signal name
1	+ 10 V	11	-
2	-	12	GND
3	θSIG 0	13	ECLK-
4	ECLK+	14	GND
5	θSIG 1	15	-
6	-	16	GND
7	-	17	-
8	-	18	-
9	ZERO+	19	ZERO-
10	-	20	-

Chassis ground	Shielded cable
----------------	----------------

(3) DR series motor

Pin #	Signal name	Pin #	Signal name
1	-	11	+S180
2	+S0	12	-
3	-	13	-
4	-	14	-
5	-	15	-S180
6	-S0	16	-
7	-	17	-C180
8	-C0	18	-
9	-	19	-
10	+C0	20	+C180

Chassis ground	FG Shielded cable
----------------	----------------------

Terminal for <CN2>

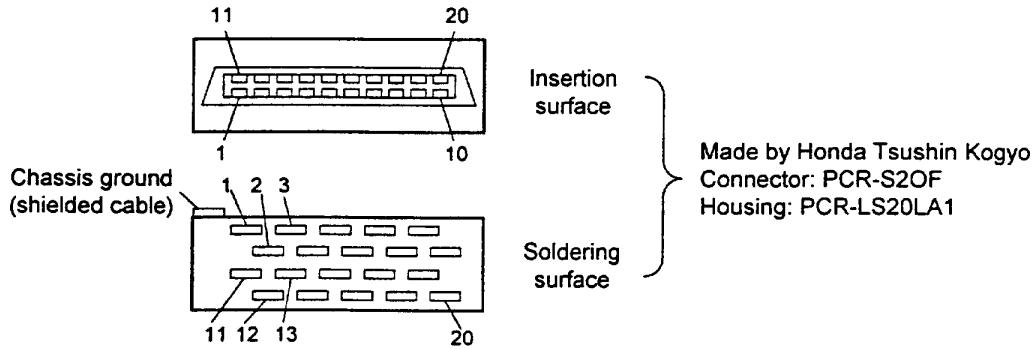

Electric wire specification	■ 0.2 mm <sup>2</sup> multiple-core twisted pair batch shielded cable, 30 m or less in length*		
Optional cable			
	DM1004B/C	DM series motor (other than the ones described to the left)	DR series motor
	CE7900C-□□□	CE7900M-□□□	CE7900R-□□□

\* Within 10 m only for small-diameter/flat types (DM1004B/C).

### 3.6 Wiring of Contact I/O (1) Cable

<CN4> terminal

Pin #	Signal name	Pin #	Signal name	Pin #	Signal name	Pin #	Signal name	Pin #	Signal name
1	COMP1	11	IN_I_CODE.1	21	IN_ERR_RES ET	31	IN_ROTDIR_S TR_OPT.1	41	(RESERVE)
2	IN_EMG	12	IN_I_CODE.2	22	IN_M_ANS	32	IN_ABS_STR_ OPT	42	OUT_ CODE.0
3	IN_SERVO	13	IN_I_CODE.3	23	IN_ERRCODE REQ	33	(RESERVE)	43	OUT_ CODE.1
4	IN_MODE_S TART	14	IN_I_CODE.4	24	(RESERVE)	34	OUT_CPURD Y	44	OUT_ CODE.2
5	IN_MODE_S TOP	15	IN_I_CODE.5	25	IN_POS_INH	35	OUT_SRDY	45	OUT_ CODE.3
6	IN_MODE.0	16	IN_I_CODE.6	26	IN_JOG_UP	36	OUT_MODE_ EXE	46	OUT_ CODE.4
7	IN_MODE.1	17	IN_I_CODE.7	27	IN_JOG_DN	37	OUT_ERR	47	OUT_ CODE.5
8	IN_MODE.2	18	IN_PRG_RE WIND	28	IN_OVERRID E_SEL	38	OUT_ALARM	48	OUT_ CODE.6
9	IN_MODE.3	19	IN_INTERLO CK	29	IN_SIGN_IND EX	39	OUT_M_EN	49	OUT_ CODE.7
10	IN_I_CODE.0	20	In_ABORT	30	IN_ROTDIR_S TR_OPT.0	40	OUT_ERRCO DE OUT	50	COMN1

Terminal for <CN4>  
 Made by Honda Tsushin Kogyo  
 Connector: PCR-S50FS  
 Housing: PCR-LS50LA

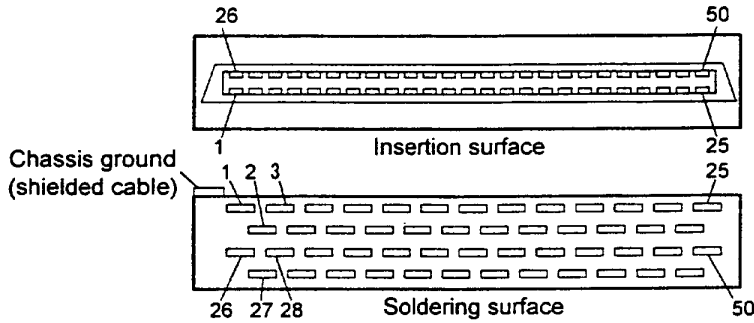

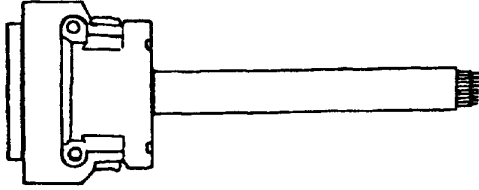
<p>Electric wire specification</p>	<ul style="list-style-type: none"> <li>■ 0.2 to 0.5 mm<sup>2</sup> or more, multiple-core batch shielded cable, 3 m or less in length</li> <li>■ Optional cable: CP7802S-□□□</li> </ul> 
------------------------------------	--

# 3

## Connection and Wiring

### 3.7 Wiring of Contact I/O (2) Cable

Pin #	Signal name
6	COMN2
5	OUT_AREA
4	OUT_AREA0
3	(reserve)
2	OUT_COIN
1	COMP2

Electric wire specification	<ul style="list-style-type: none"> <li>■ 0.2 to 1.5 mm<sup>2</sup> or more, multiple-core batch shielded cable</li> <li>■ Do not solder the core wire (twisted wire). It may cause a contact problem.</li> </ul>
-----------------------------	--

See the panel surface of the driver for pin numbers.

<CN5>

Made by Phoenix Contact  
(plug: MCI, 5/6-ST-3, 81)

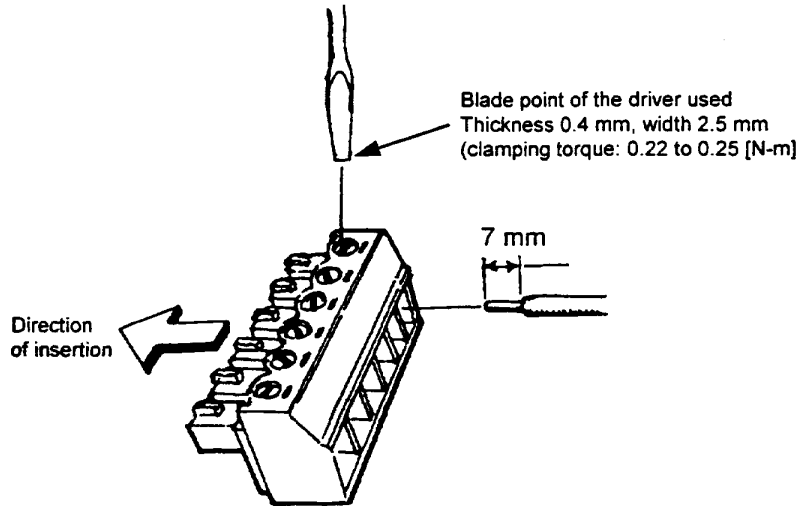

### 3.8 Wiring of Sensor Brake Terminal

Pin #	Signal name
7	XBRKN
6	XBRKP
5	(NC)
4	XOTU
3	XOTD
2	XORG
1	COMP0

Electric wire specification	<ul style="list-style-type: none"> <li>0.3 to 0.75 mm<sup>2</sup>, electric wire coating with 10 mm of the core exposed at the tip</li> <li>If a twisted wire is used, the diameter of the strand should be <math>\phi</math> 0.18 or larger.</li> </ul>
-----------------------------	--

See the panel surface of the driver for the pin numbers.

<TB2> Made by Sato Parts (ML1900H)

1) Push down the lever with a screwdriver.

2) Insert the wire deeply.

3) Push up the lever (until you hear the click)

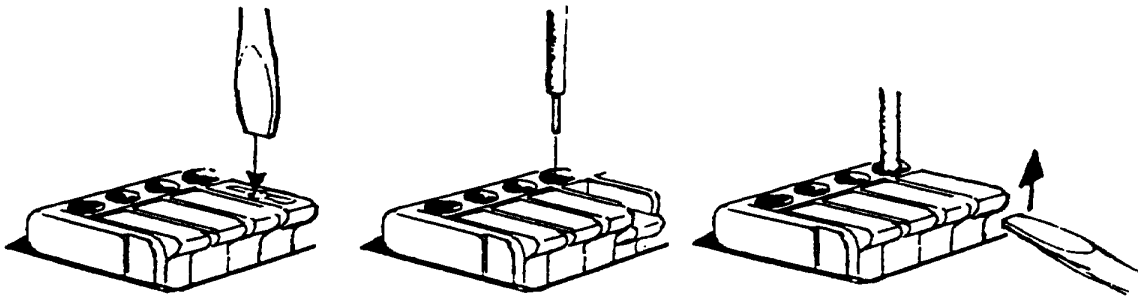

Example of sensor connection (sensor: EE-SX670 manufactured by Omron)

The recommended sensor logic is B contact.

Set the sensor to OFF when the light is shielded. The sensor described above will be set to OFF when the light is shielded by the following result.

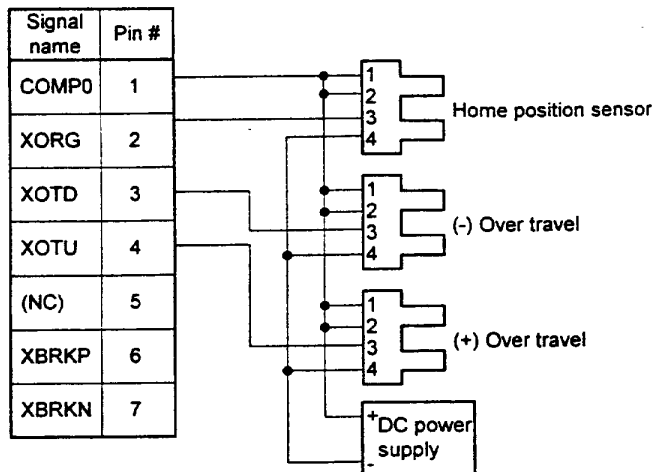

[Electrical specifications]

Input specifications	
Rated voltage	12~24VDC (±10%)
Rated input current	4.1 mA/point (at 12 VDC) 8.5 mA/point (at 24 VDC)
Input impedance	3.0k $\Omega$
Operating voltage (relative to COMP*)	At OFF: 3.0 VDC or less At ON: 9.0 VDC or more
Allowable leakage current	OFF is guaranteed at 1.0 mA or less.

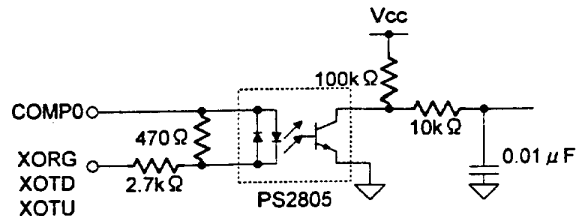

# 3 Connection and Wiring

## 3.9 Wiring of Regenerative Alarm Contact <CNA> (For 500W Type Drive Only)

This driver (with regenerative terminal) is equipped with a regenerative circuit failure detection circuit. When connecting the regenerative circuit, build a sequence circuit as shown in the figure below in order to prevent burnout incidents.

Note: Build a sequence circuit so that it will turn off the power supply at alarm operation.

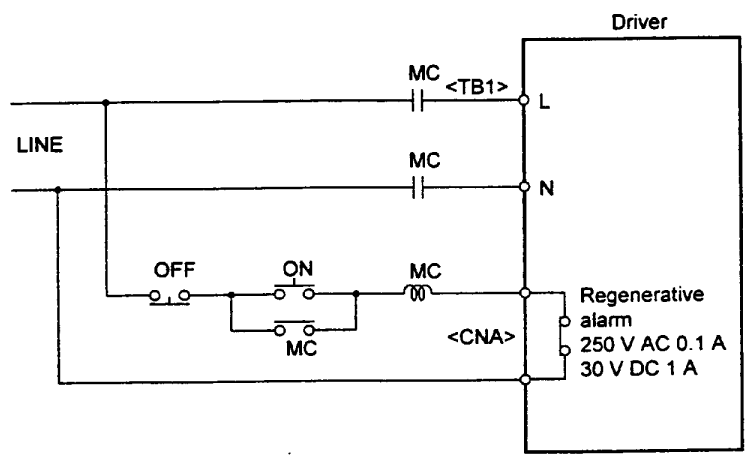

<CNA>  
Made by Phoenix Contact  
(plug: MC1, 5/2-ST-5, 08)

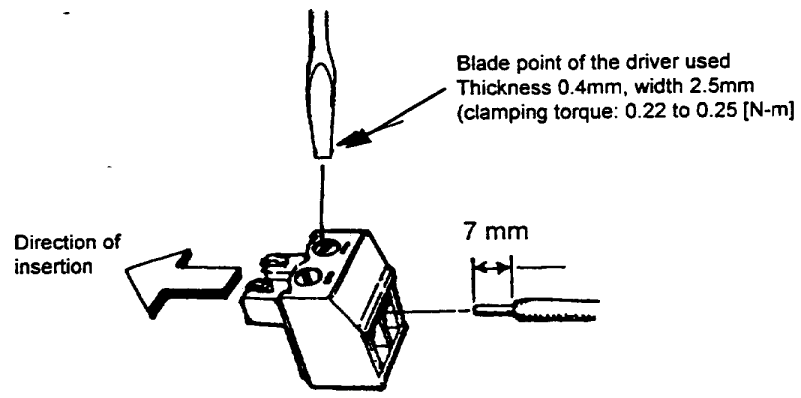

# Chapter 4 Basic Operation (Let's Operate First)

---

This chapter describes an "Example of Stand-Alone Motor Operation," which should be used as the first step in understanding the "motor/driver/PC utility." The information is provided progressively, focusing on motor tuning, homing operation, program creation (moving to a position of 50 degrees, moving with a velocity of 50 degrees/sec, reciprocating operation), and startup method. Make sure to perform the operations described in this chapter as a preliminary step before commencing device production.

- 4.1 Procedure (Flowchart)
- 4.2 Preoperation check
- 4.3 Installing the PC Utility on the PC
  - 4.3.1 Procedure
  - 4.3.2 Startup
- 4.4 Preparation
  - 4.4.1 Selecting Communication Port
  - 4.4.2 Selecting Channels
  - 4.4.3 Displaying Communication Strings
  - 4.4.4 Main Menu
- 4.5 Setting the Status to Servo ON
- 4.6 Auto-tuning
- 4.7 Performing Homing Operation
- 4.8 Performing Program Operation
  - 4.8.1 Verifying Operation Conditions
  - 4.8.2 Creating a Sample Program
  - 4.8.3 Starting the Sample Program

## 4.1 Procedure (Flowchart)

In this section, we will operate the motor according to the procedure below.

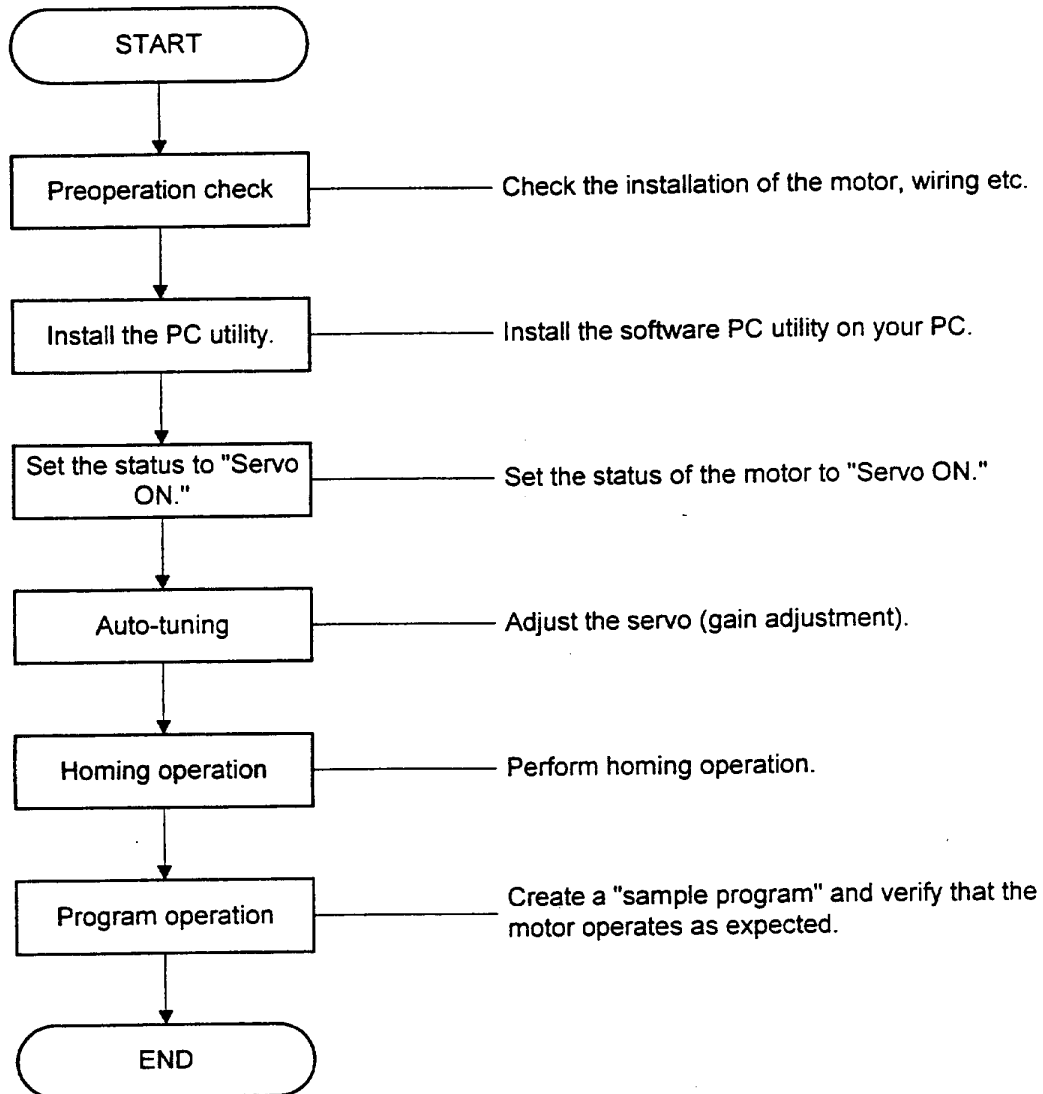

## 4.2 Preoperation check

- (1) Items to prepare
- Motor unit/driver/sensor/DC power supply
  - PC utility (floppy disk)
  - Level block for fixing the motor
  - PC (with Windows 95/98/98SE/Me/NT4.0/2000 installed)
  - Various cables
- (2) Installation and Wiring

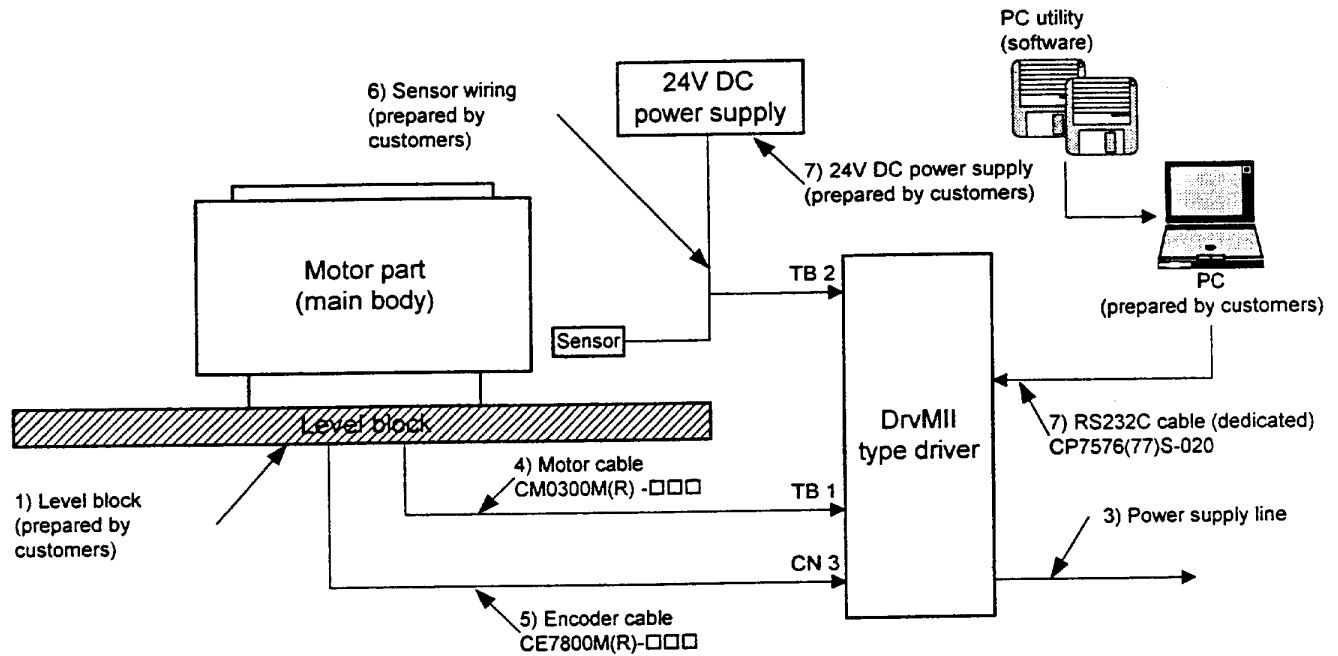

### (3) Items to be checked

- 1) Is the main body fixed on the level block?
- 2) Is the motor not interfering with peripherals?
- 3) Is the power supply line wired properly? (LINE, GND)
- 4) Is the motor cable wired properly? (VA, VB, VC, GND)
- 5) Is the encoder cable wired properly?
- 6) Is the sensor wired properly? (Origin and OT sensor)
- 7) Is the RS232C cable wired properly?
- 8) Is the operation mode set to RS232C?  
(Is bit 2 of SW1 of the driver set to OFF?)

Check

- 
- 
- 
- 
- 
- 
- 
-



## 4.3 Installing the PC Utility on the PC

### 4.3.1 Procedure

Installation under Windows 95/98/98SE/Me/NT4.0/2000

The M2 PC utility (hereinafter referred to as the "PC utility") runs on Windows 95, 98, 98SE, Me, WindowsNT4.0 and 2000. It can be installed via "Add/Remove Programs" under the "Control Panel" in Windows. If an older version of the PC utility is present, delete it first and then install the new version. Display the "Properties of Adding/Removing Programs" dialog box and click "Set Up (1)." Then proceed according to the instructions displayed on the screen. The PC utility setup program starts up. Proceed with the setup according to the instructions on the screen. A dialog box for determining the directory in which to install the PC utility appears (see Figure 4.3.1).

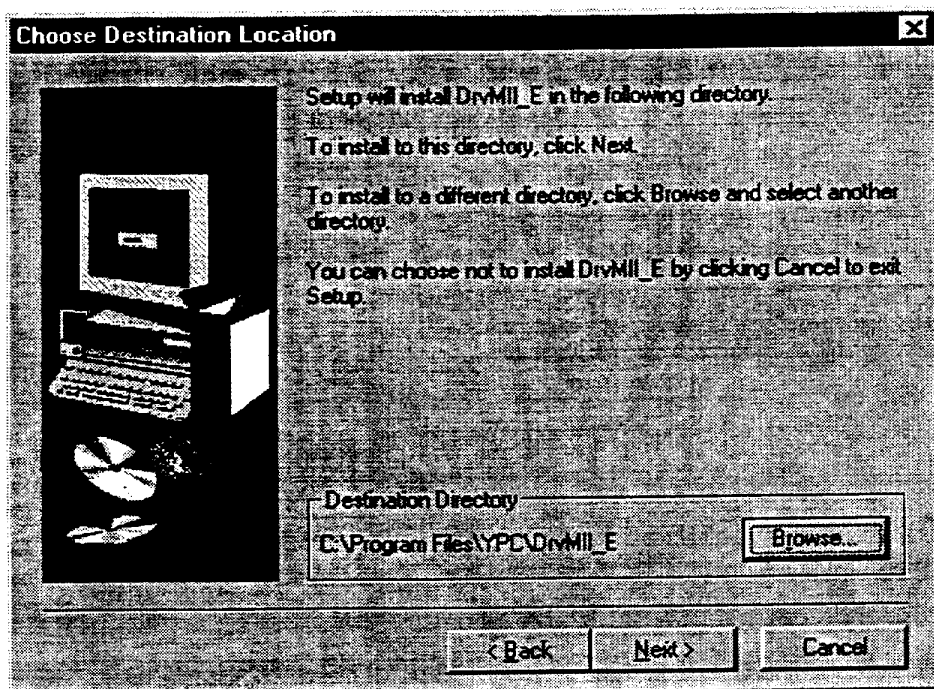

Figure 4.3.1 "Choose Destination Location" dialog box

Click "Browse" to display the "Select Directory" dialog box and select the desired drive and directory. Click "Next" to display "Select Program Folder" (see Figure 4.3.2).

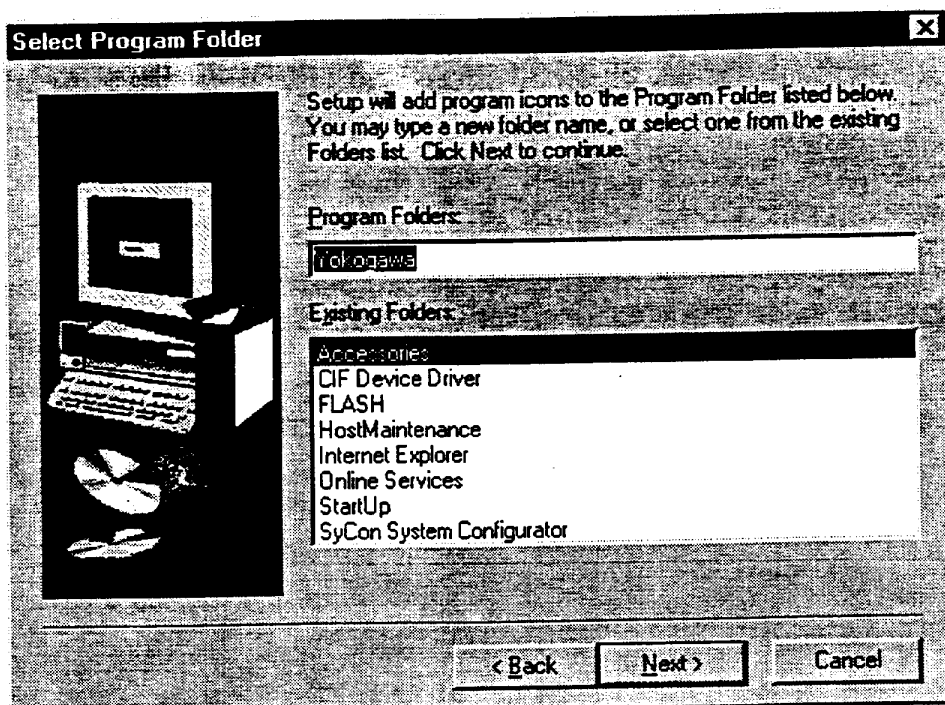

Figure 4.3.2 "Select Program Folder" dialog box

Select a program folder and click "Next." The installation begins. Follow the instructions on the screen and change disks. When the setup is completed, the "Setup Complete" dialog box appear (see Figure 4.3.3).

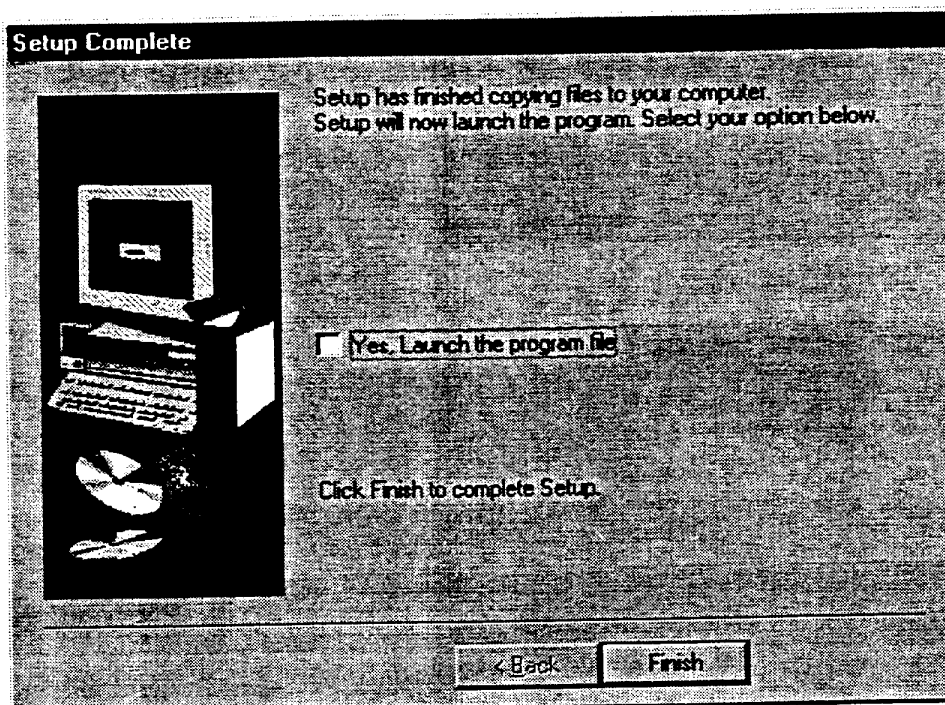

Figure 4.3.3 "Setup Complete" dialog box

To start the program, select "Launch the program file" and click "Finish." If you do not want to start the program, just click "Finish." If you are prompted to restart the computer, simply follow the message and restart it.

Note: Remove the floppy disk before restarting the computer.

4.3.2 Startup

- 1) To start the PC utility, click "Start," "Program (P)," "DrvMII" and then "DrvMII."

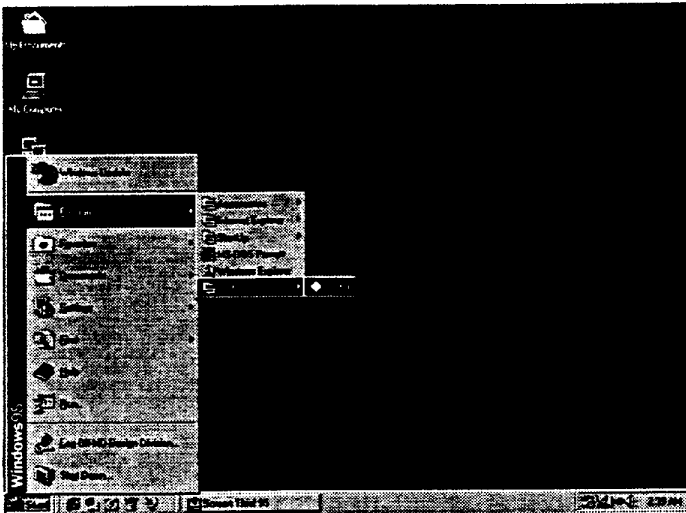

Figure 4.3.4 "Startup"

- 2) An "Opening" dialog box is displayed for several seconds and then the PC utility starts up.

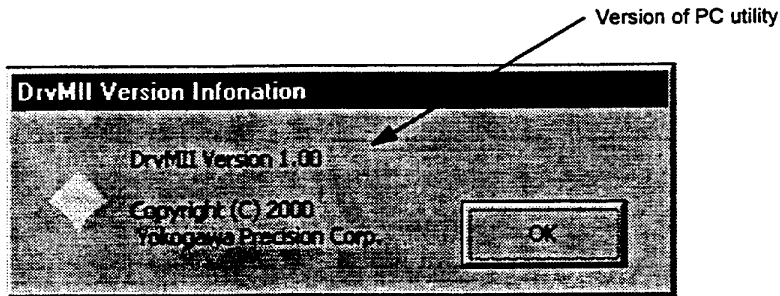

Figure 4.3.5 "Opening" dialog box

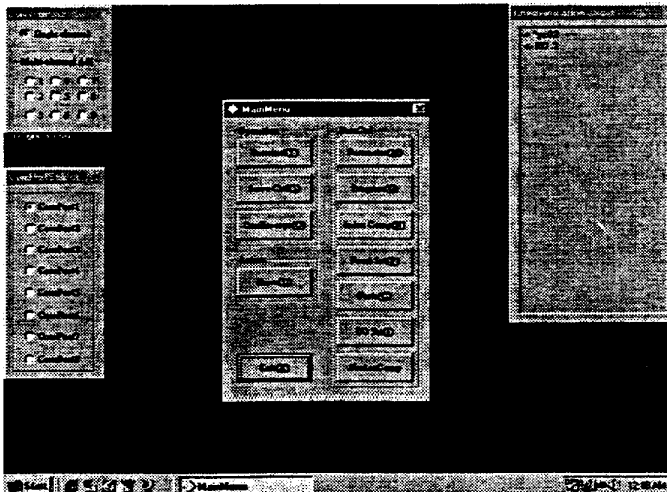

Figure 4.3.6 After starting up the PC utility

## 4.4 Preparation

Connect the serial port of the PC with the serial port of the driver with a dedicated cable. (Do not use commercial off-the-shelf cables. There is a terminal for which 5V is output from the driver for connecting with the teaching box.)

### 4.4.1 Selecting Communication Port

When you start the PC utility, the “ComPortSelect” dialog box appears in the left side of the screen (see Figure 4.4.1). Change the setting according to the communication port of the connected PC.

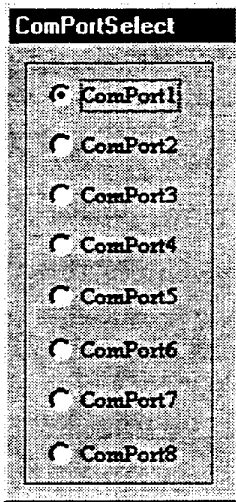

Figure 4.4.1 “ComPortSelect”

Note: Settings made in the “ComPortSelect” dialog box are stored in a file. It is not necessary to make settings from the next time you start the PC utility. Change the setting as necessary.

### 4.4.2 Selecting Channels

When you start the PC utility, the “Communication mode” dialog box appears in the upper left corner of the screen (see Figure 4.4.2). If you are using one driver, select a single channel, and if you are using multiple drivers, select multi-channel addresses. (See Chapter 6 for how to make setting on the driver side.)

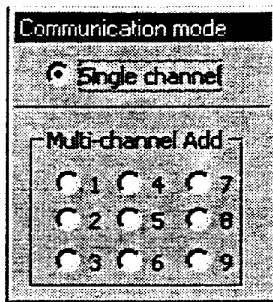

Figure 4.4.2 “Communication mode”

Note: The settings made in the “Communication mode” dialog box are not stored. When the PC utility is started up, a single channel is always set.

# 4

## Basic Operation (Let's Operate First)

### 4.4.3 Displaying Communication Strings

When you start the PC utility, the "Communication string" dialog box appears in the upper right corner of the screen. (See Figure 4.4.3.) Any strings that the PC utility sends to the driver as well as any strings received from the driver are displayed regardless of the menu.

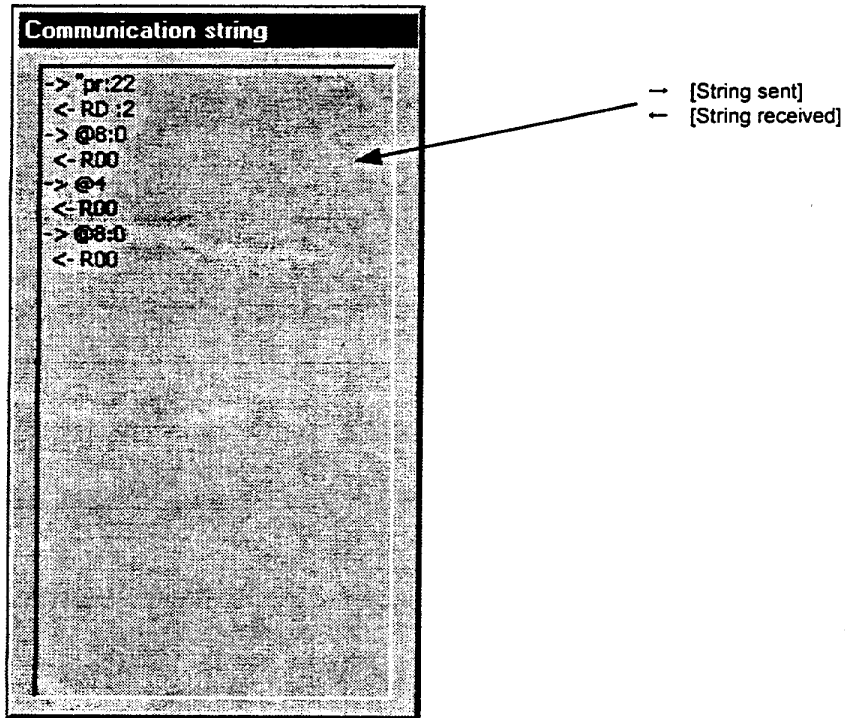

Figure 4.4.3 "Communication string"

#### 4.4.4 Main Menu

When you start the PC utility, the “MainMenu” dialog box appears (see Figure 4.4.4). See the following chapters for how to start the actual operation.

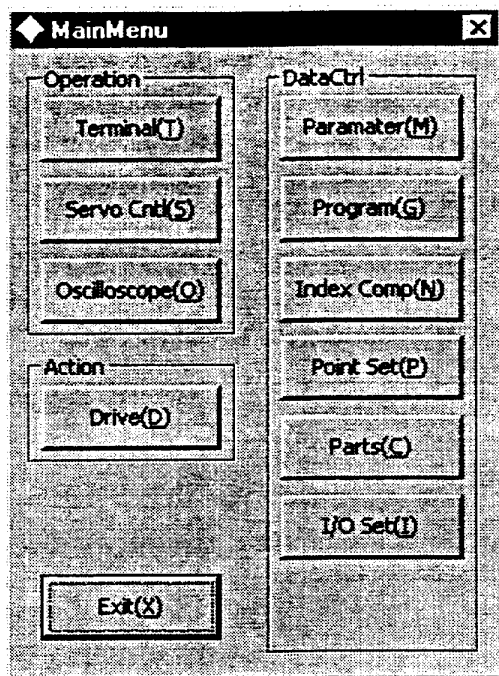
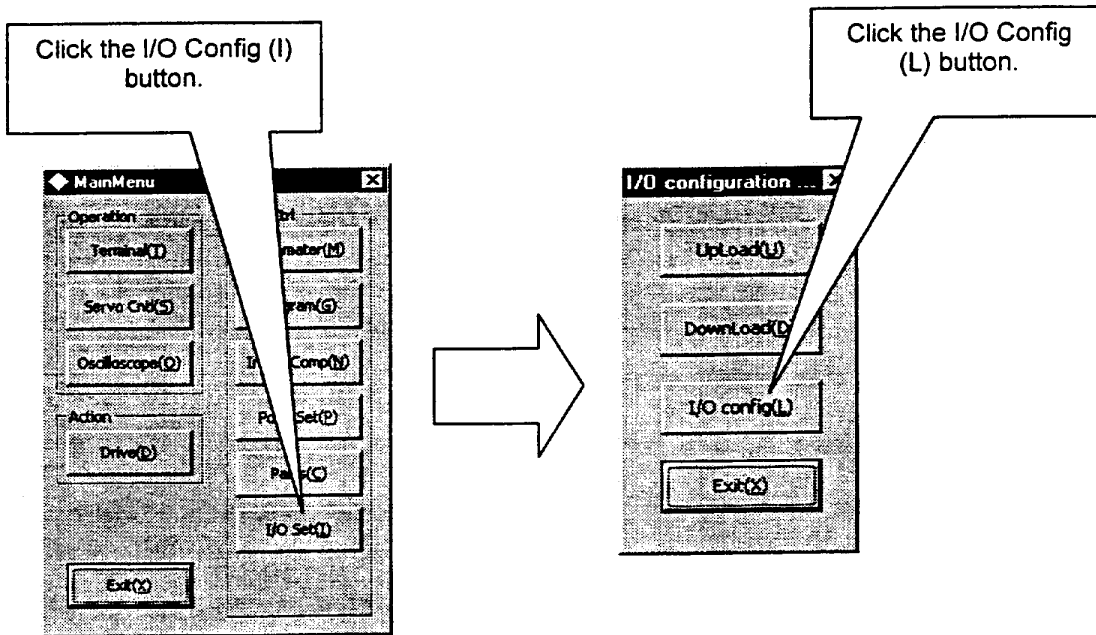

Figure 4.4.4 “MainMenu” dialog box

## 4.5 Setting the Status to Servo ON

The driver can be put into Servo On status through the following operation.

- (1) Click the "I/O Config (I)" button in the "MainMenu" and then the "I/O config (L)" button.



- (2) Enable Servo ON. Click the checkmark of "1" under DI and then click the Set (S) button.

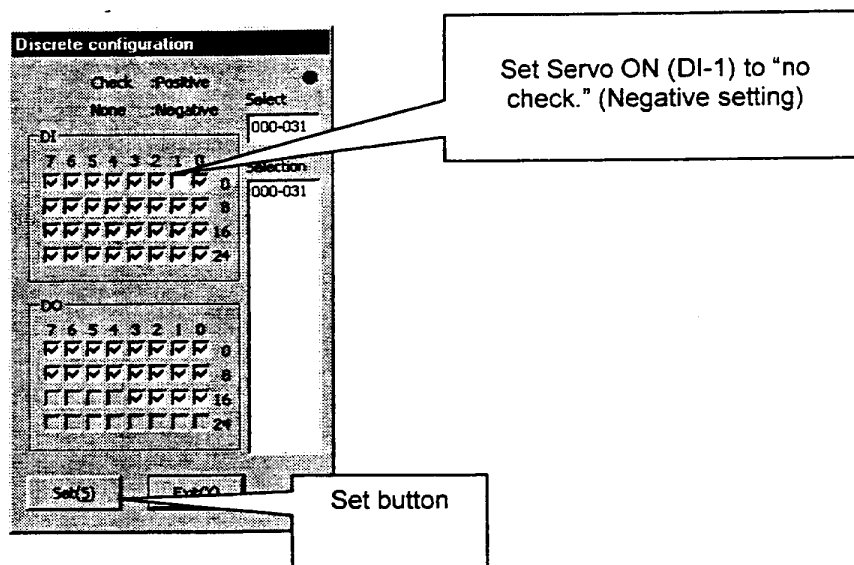

### Caution

Make sure to click the "Set" button after finishing the setting (the status will become Servo ON). Verify that the "S-RDY" LED on the front panel is turned on.

- (3) Reset the driver according to the message in the dialog box.

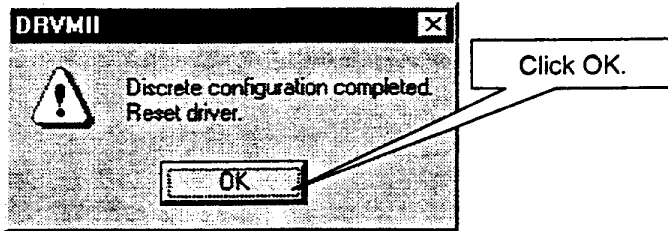

- (4) Verify that the driver is reset and the "SRDY" LED on the front panel is turned on.



## 4.6 Auto-tuning

The auto-tuning can be performed according to the following procedure.

- (1) Checking the rotation direction  
Check the rotation direction (CW/CCW) of the motor.

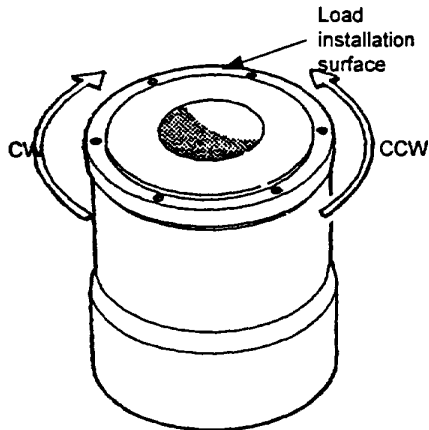

**Caution**

Look carefully from both sides of the load installation surface to check the CW/CCW movement. When started, the motor operates in the CCW direction. Take extra care to ensure that there is no mechanical interference with the rotor, which is currently in the stop position.

- (2) Click the "Servo Cntl (S)" button on the "MainMenu."

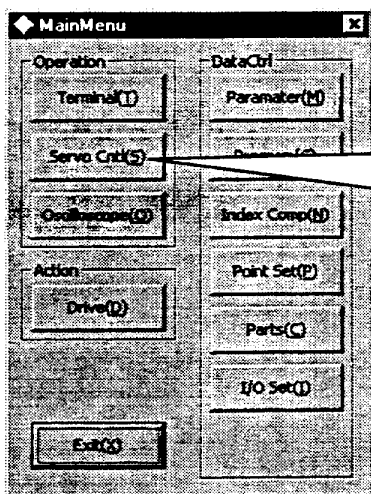

Click the Servo Cntl  
button

- (3) Click Auto Tuning Start (tuning starts).
- (4) Follow the message on the dialog box and click “OK” to start the auto-tuning operation.

**Caution** ⚠ The rotor rotates a maximum of 30° (seven times of reciprocating operation) in the CW direction. The operation width varies depending on the velocity rating of the motor. Take extra care not to cause any mechanical interference around the rotor.

<How to calculate the operation width>  

$$\text{Operation width (degree)} = \text{motor velocity rating [rps]} \times 0.02 \times 360$$

- (5) Each parameter setting value is displayed and the auto-tuning is automatically terminated.

## 4 Basic Operation (Let's Operate First)

### 4.7 Performing Homing Operation

A homing operation can be performed according to the following procedure.

- (1) Checking the rotation direction  
Check the rotation direction (CW/CCW) of the motor.

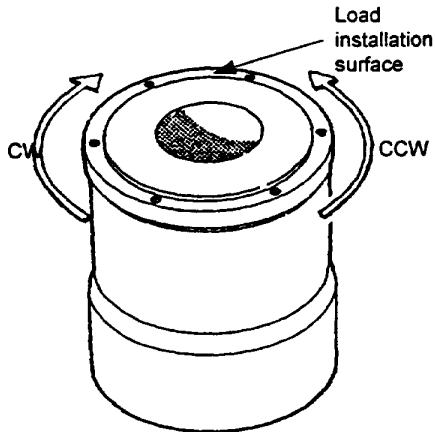

#### Caution

Look carefully from both sides of the load installation surface to check the CW/CCW movement. When started, the motor operates in the CCW direction. Take extra care to ensure that there is no mechanical interference with the rotor.

- (2) Check the setting of the homing direction through the PC utility.  
Click "Drive" in the Main Menu, then "Homing."

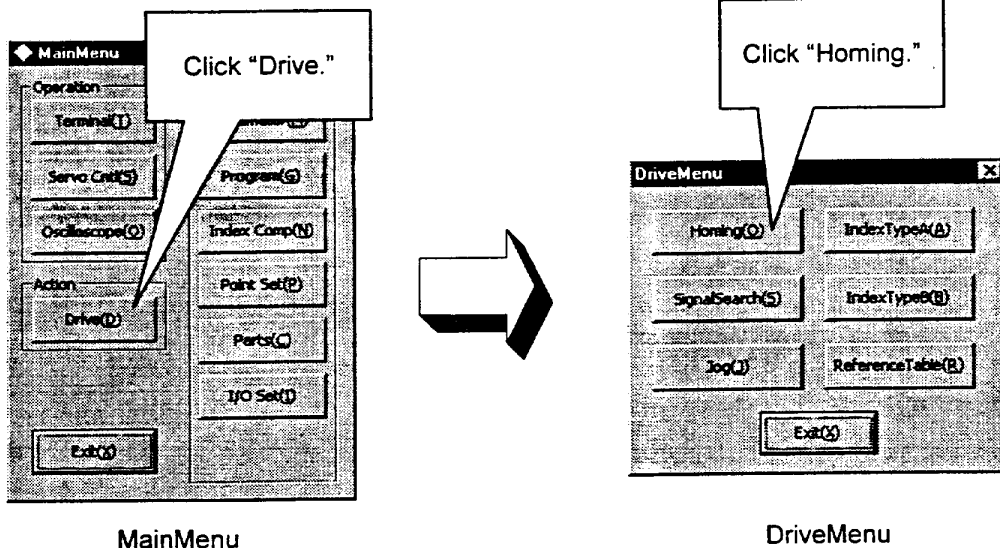

(3) Set the "homing direction" in the "Homing" dialog box.

1) The current setting values are displayed in the Setting value box by clicking grid "#20."

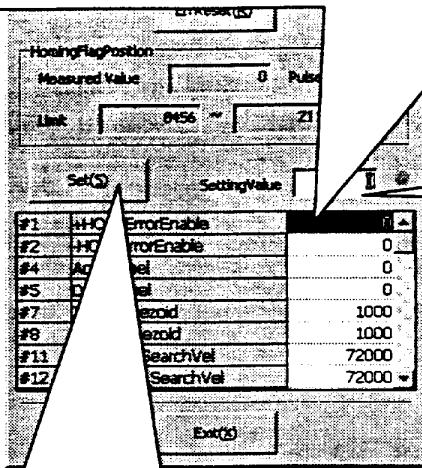

2) Enter 1 in the Setting Value box. Make sure to press the return key; otherwise the entry is not made valid.

The current setting values for the "homing related" parameters are displayed.

3) Click the "Set" button.

**Caution** The initial value that should be set depends on the homing direction. Enter "#20 = 1" if the homing direction is CW and "#20 = 0" if it is CCW.

(4) Click the "Start" button to start the homing operation.

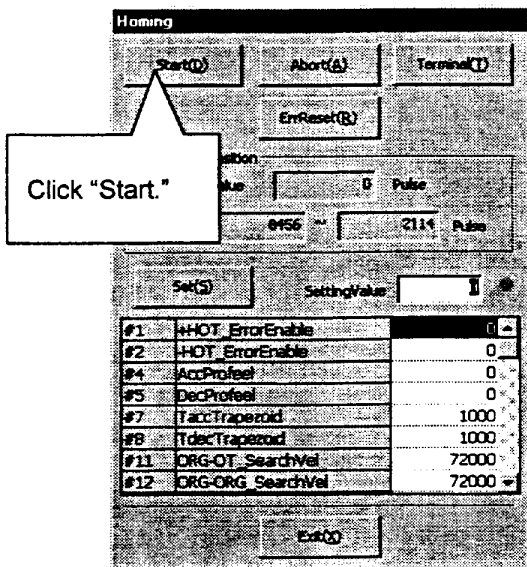

**Caution**

- The homing operation finishes automatically after the operation is completed. In the event of
  - The homing operation does not finish, and
  - The motor does not stop even when the home position sensor is detected, Click "Abort (A)" to stop the motor, then check "wiring" and "auto-tuning" again.
- If a homing abnormality message is displayed, follow the message to adjust the flag position using the limit value as a guideline. If an error occurs, press "ErrReset" as well.

## 4 Basic Operation (Let's Operate First)

### 4.8 Performing Program Operation

In this section, you will create a sample program and verify that the motor operates as expected.

#### 4.8.1 Verifying Operation Conditions

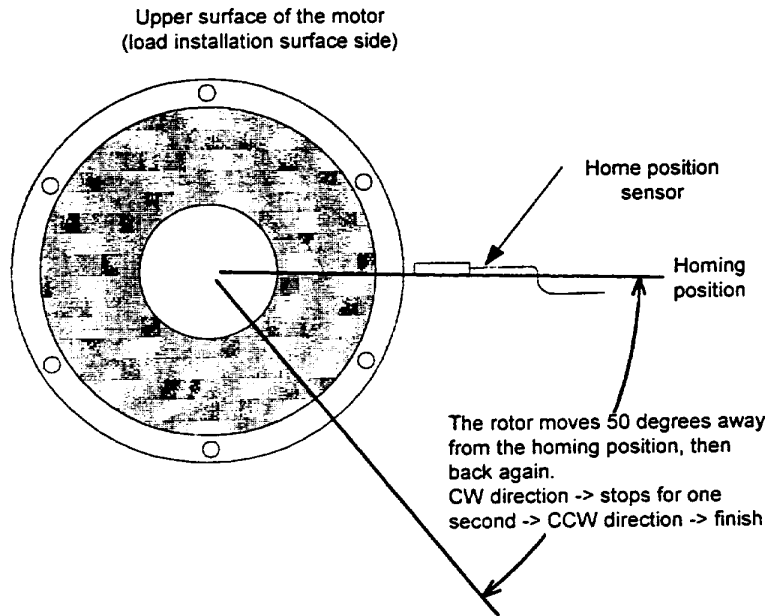

<Velocity pattern>

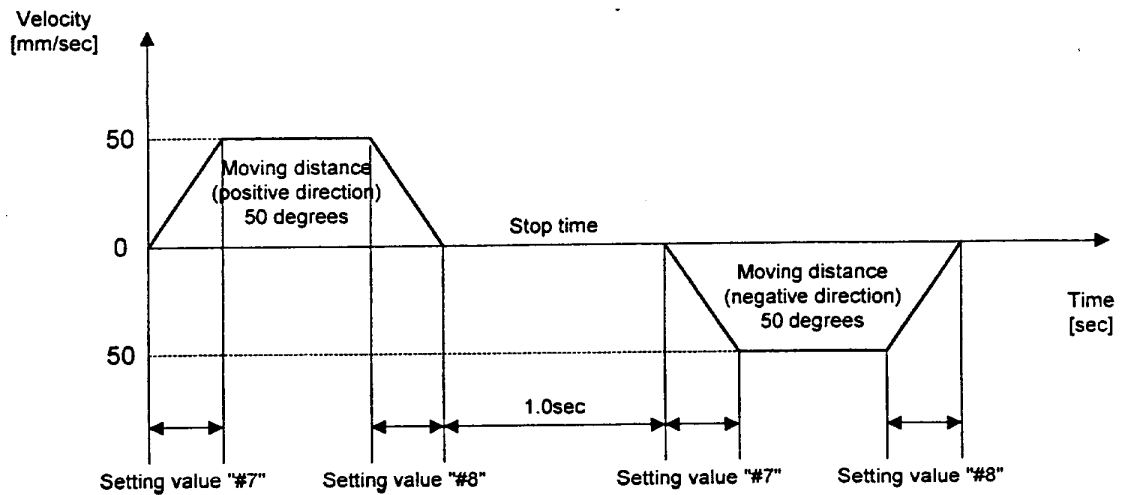

Set the acceleration time (#7) and deceleration time (#8) according to the operation conditions (the initial value is 1000msec for both #7 and #8). Refer to Section 4.8.3, "Starting the Sample Program, (4) simplified terminal" for how to set these values.

## 4.8.2 Creating a Sample Program

Select "Program" in the "MainMenu," then "Edit" in the "Program Manager" menu in order to display the "Program Edit" screen and enter a program.

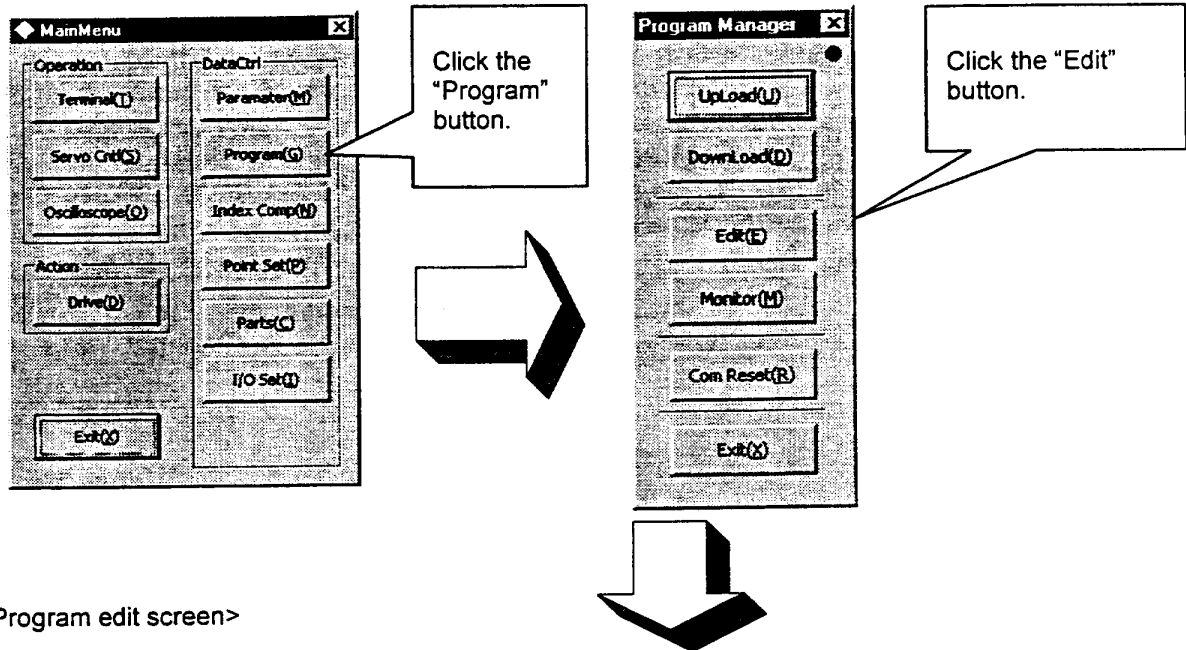

<Program edit screen>

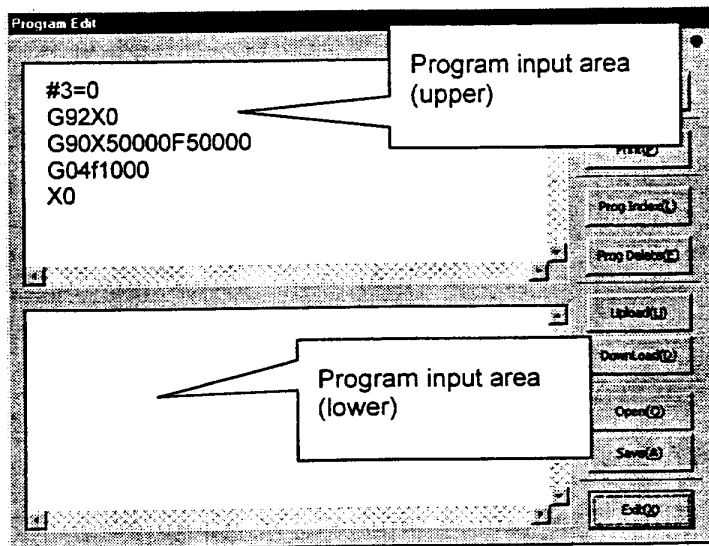

**Caution** The program should be entered in the "input area (upper)" at this point. Programs should be input in half width, case-sensitive letters.

The following is the description of the sample program.

#3=0	Set the cam profile move selection to a trapezoidal move.
G92X0	Coordinate selection (current position = 0)
G90X50000F50000	Move to a position 50 degrees from the home position at a velocity of 50 degrees/sec. (absolute command)
G04f1000	Stop 1 second.
X0	Move from the 50 degrees position to the home position at a velocity of 50 degrees/sec. (absolute command)

# 4

## Basic Operation (Let's Operate First)

(2) Press "DownLoad" in order to register the program.

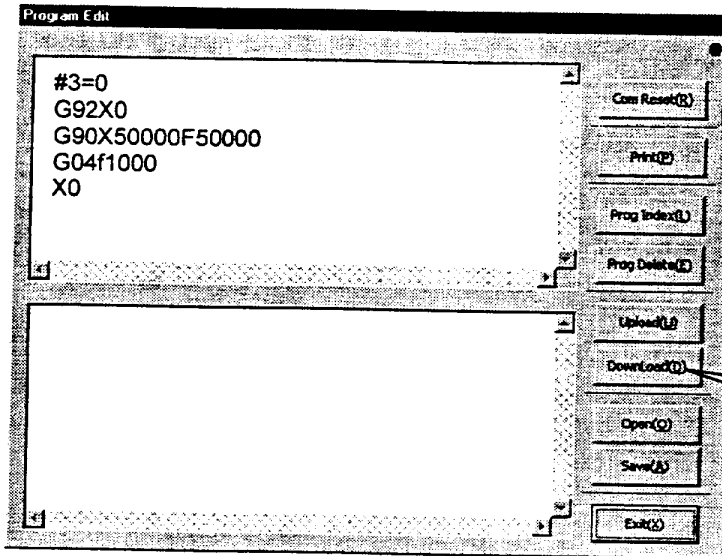

(3) Enter "1" for the program number and click the "OK" button.

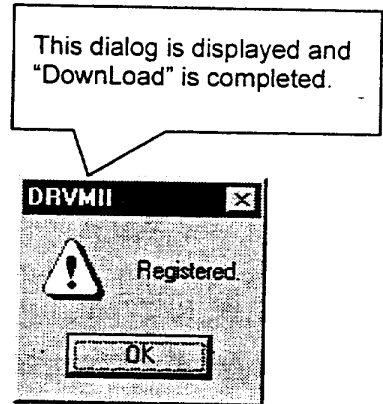
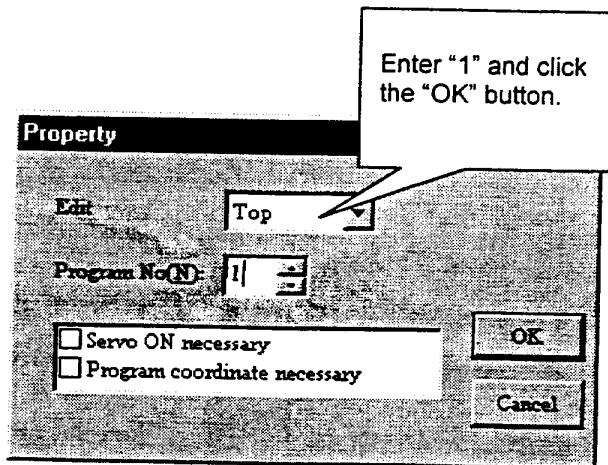

(4) Click the "Exit" button on the "Program Edit" screen to return to the "MainMenu."

### 4.8.3 Starting the Sample Program

- (1) Click "Program" on the "MainMenu," and then "Monitor."

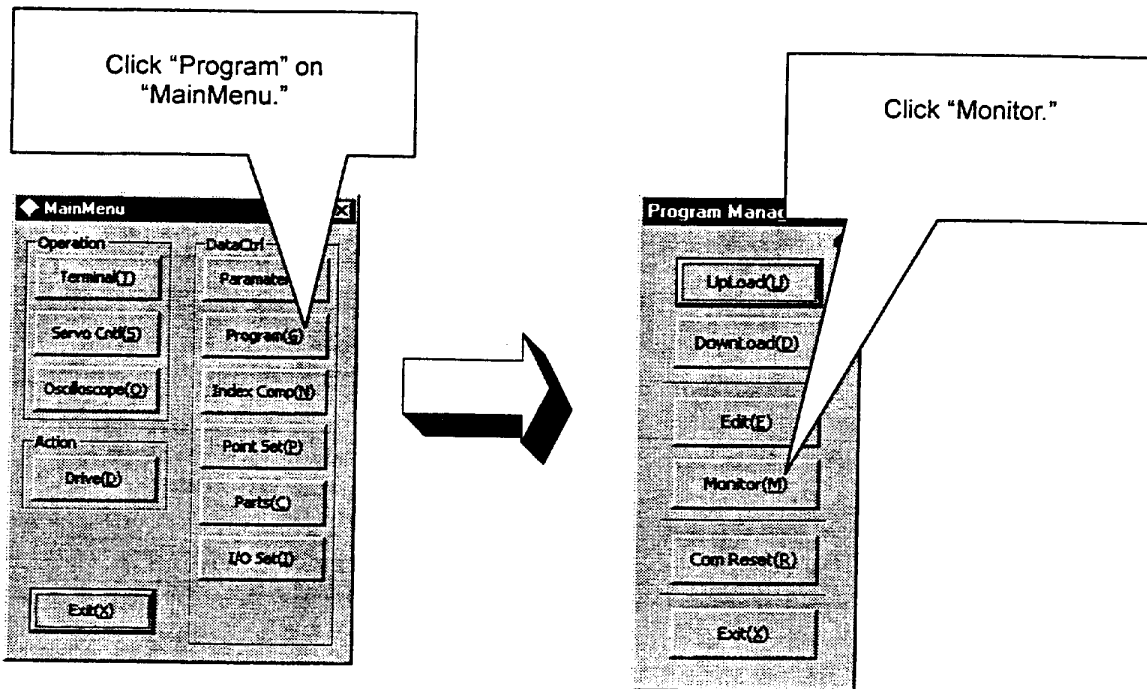

- (2) Leave the Get Prog No. selection at "ALL" in the "Program Monitor Init" dialog box and click "OK."

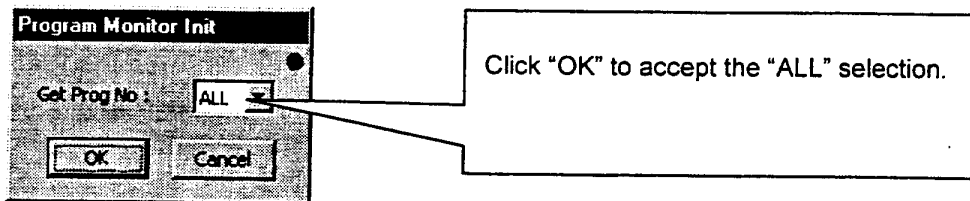

- (3) Leave the "Mode" at "Normal" in the "Setting Option" dialog box, and click "OK."

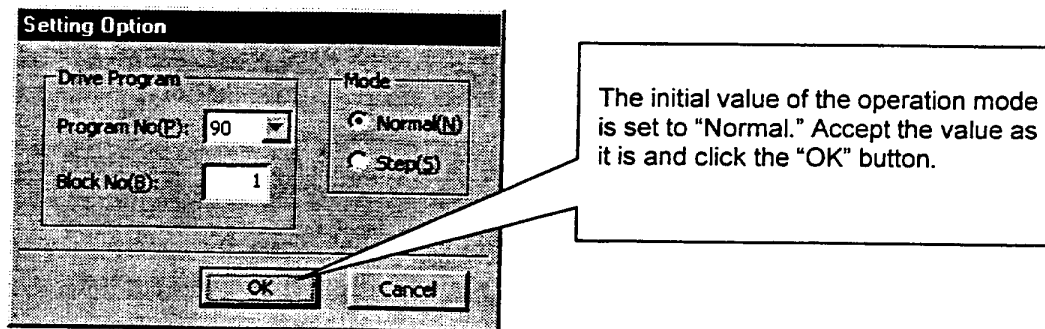



# 4

## Basic Operation (Let's Operate First)

- Click the "Start" button in the "Program Monitor" screen to start the operation.  
The program starts up once and then stops. If you want to stop the program in the middle of the operation, click the "Stop" button.

<Dialog box before starting>

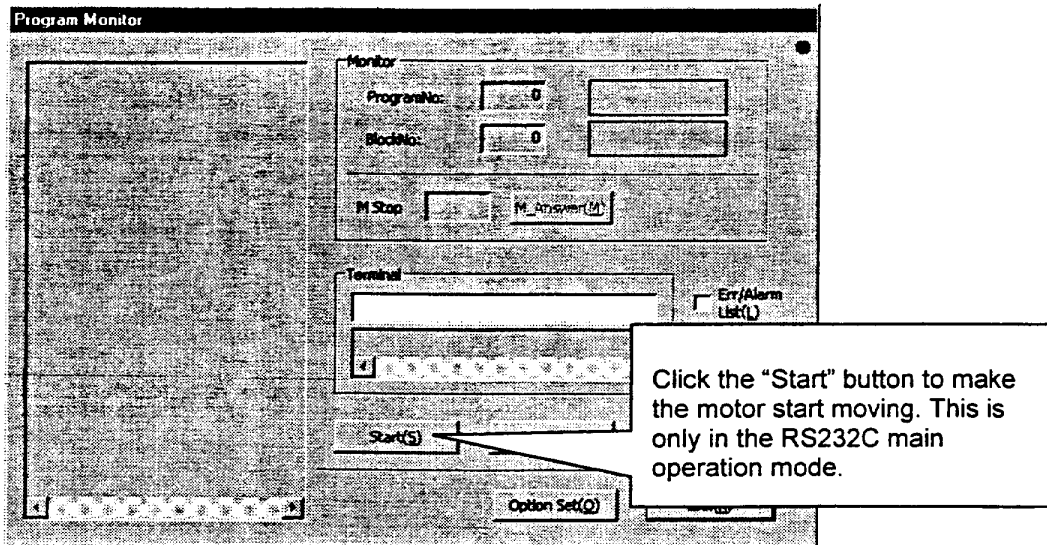

<Dialog box during operation>

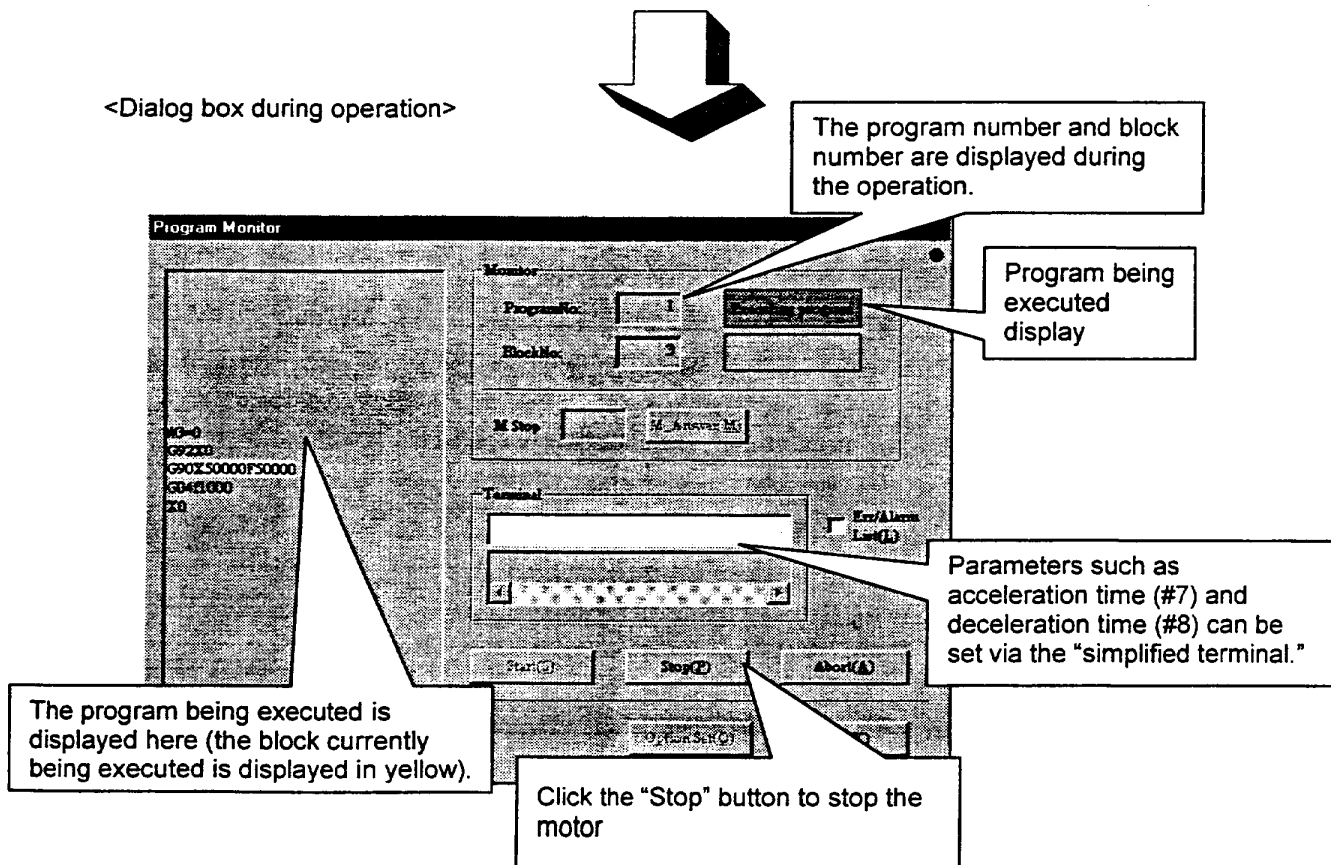

The basic operation is now complete. Refer to the Function Manual for details about the actual operation.

# Chapter 5

## Functions

---

- 5.1 Operation Mode
- 5.2 Parameters and Monitors
- 5.3 Operation Functions
- 5.4 Coordinate System
- 5.5 Acceleration/Deceleration Function
- 5.6 Programming Language
- 5.7 M Function
- 5.8 Control System
- 5.9 Other Functions
- 5.10 Special Parameter Processing

## 5.1 Operation Mode

The two interfaces, an *RS232C interface* and a *PLC interface*, are available for operation of this driver. The operation items that are available for these interfaces are not identical, but the main operations of the driver can be performed with either of the interfaces, such as operating the motor. However, if an operation, which is incompatible with one of the interfaces, is performed while operating via the other interface, the devices connected to the operating interface are no longer able to manage the conditions. In order to avoid such conditions, the driver controls the interfaces through a concept called *operation mode*, in which the main operations at run time, such as the operation of the motor, can only be performed via one of the interfaces.

The operation mode is set by the status of the bit 2 of the SW1 switch on the front panel when the power is turned on. If the switch is ON, the PLC interface is permitted to perform the main operation. If the switch is OFF, the RS232C interface is permitted to perform the main operation.

The following explains the operation items available in each interface as well as their relationship with the operation mode. The operation display pendant (TBX) conforms to the RS232C interface.

Command name	Main operation permission: RS232C			Main operation permission: PLC			
	Operation device	RS232C	TBX	PLC	RS232C	TBX	PLC
Emergency stop command		-	○	○	-	○	○
Servo ON/OFF		ON/OFF		Allowed/ Prohibited	X		ON/OFF
Start		○		X	X		○
Stop		○		X	X		○
Abort		○		○	○		○
Error reset		○		○	○		○
Interlock		-		○	-		○
Velocity override switching		-		○	-		○
Program auto rewind		-		○	-		○
Integral position control operation switching		○		X	X		○
Homing offset position settings		○		-	○		-
Coordinate system settings		○		-	○		-
M function	<i>According to #102 Enabling the selection of RS232C for the M function interface parameter settings.</i>						
Jog move command	<i>According to #217 Jog move operation: RS232C selection parameter settings.</i>						
Get error code	According to the monitors #345 and #346		(○)		According to the monitors #345 and #346		(○)
Parameter settings	According to parameter command		(○)		According to parameter command		(○)
Parameter/monitor read	According to parameter command		(○)		According to parameter command		(○)

Note: Items marked with (○) may be available depending on the type of PLC interface.

## 5.2 Parameters and Monitors

The group of variables expressed by #\*\*\* is called *parameters and monitors*. Parameters/monitors are classified according to their numbers as follows.

Parameter No.	Parameter type	Backup	Comments
0 to 199	General parameters	Stored	Always possible to read and write.
200 to 299	Mechanical setting parameters	Stored	Reading is always possible, but writing is possible only when operating in mechanical setting mode.
300 to 399	Monitors	-	Read only. Reading is always possible, but writing is not possible at any time.
400 to 449	Registration parameters	Stored	Always possible to read and write. The user can use them freely.
500 to 549	Volatile parameters	Not stored	Always possible to read and write. The user can use them freely. Set to 0 when the power is turned on.
600 to 699	Point set (value)	Stored	Always possible to read and write. Used during table reference operation.
700 to 799	Point set (option)	Stored	Always possible to read and write. Used during table reference operation.

By referring to any of the parameters/monitors in the form of #\*\*\*, their values can be referenced (read) by a program or command. It is also possible to change (write) their values by a program or command, as long as the values are within the range allowed for each parameter/monitor.

The following is a list of the setting ranges of the parameters/monitors. General parameters and mechanical setting parameters are explained separately. Moreover, the setting ranges of the monitors are not listed because writing is not allowed.

Parameter No.	Minimum value	Maximum value	Initial value
400 to 449	-999999999	999999999	0
500 to 549	-999999999	999999999	0
600 to 699	-999999999	999999999	0
700 to 799	0	7	0

### 5.2.1 General Parameters

These parameters can be read and written at all times and an operational meaning is assigned to each. The details of each parameter will be explained separately.

Note that these parameters are stored in the driver; they will not be deleted even if the power is turned off.

### 5.2.2 Mechanical Setting Parameters

It is always possible to read these parameters, but writing is possible only when operating in mechanical setting mode. These parameters are set only once when the device is started up. An operational meaning is assigned to each. The details of each parameter will be explained separately.

Note that these parameters are stored in the driver; they will not be deleted even if the power is turned off.

Note: If these parameters are changed during execution in mechanical setting mode, the changes made to the values will not be reflected until the power is turned on again. Therefore, please note that if you try to read a parameter value after you change the parameter, the value before the change is read until you turn the power off and on again.

### 5.2.3 Monitors

These variables are used to display the driver's status. Only reading is allowed at all times and each has an operational meaning. The details of each parameter will be explained separately.

### 5.2.4 Registration Parameters

These variables can be used freely by the user. Reading and writing are always possible. There is no operational meaning assigned to them.

Note that these parameters are stored in the driver; they will not be deleted even if the power is turned off.

### 5.2.5 Volatile Parameters

These variables can be used freely by the user. Reading and writing are always possible. There is no operational meaning assigned to them.

Note that these parameters are not stored in the driver; they are all initialized to 0 when the power is turned on.

### 5.2.6 Points Set (Value and Option)

These values represent data used in table reference operation. Point set (value) and point set (option) are used in pairs. The point set (value) obtained by adding 600 to the specified table entry is used as a target value or relative value for positioning, and the point set (option) obtained by adding 700 to the specified table entry is used as optional data for the moving method at positioning.

The entries in the point set (value) are given in operation units.

The entries in the point set (option) have the following meaning.

- 0 Moving direction for incremental instruction, rotational coordinates is Type0.
- 1 Moving direction for incremental instruction, rotational coordinates is Type1.
- 2 Moving direction for incremental instruction, rotational coordinates is Type2.
- 3 (Reserved)
- 4 Moving direction for absolute instruction, rotational coordinates is Type0.
- 5 Moving direction for absolute instruction, rotational coordinates is Type1.
- 6 Moving direction for absolute instruction, rotational coordinates is Type2.
- 7 (Reserved)

Note that these parameters are stored in the driver; they will not be deleted even if the power is turned off.

Note: Regarding the moving direction for rotational coordinates

Type0 Proximity rotational move (multiple rotations are not allowed).

Type1 Does not cross the rotational coordinate's home position (multiple rotations are not allowed).

Type2 Calculates the target position relative to the current rotational coordinate's home position and determines the direction (multiple rotations are allowed).

## 5.3 Operation Functions

The following operation functions, which can be used as needed, are provided to the driver. Moreover, the status called the *idle status* in which no operation is performed is provided to perform jog moves.

The start, end, and stop actions of these operations can be controlled from either the RS232C side or the PLC interface side, according to the operation mode setting when the power to the driver is turned on. Refer to the related sections (Section 6.1, "RS232C Interface" and Section 6.2, "PLC Interface") for operation methods.

The methods used to end each operation can be classified into three categories: the *self-end type* that ends automatically when the operation is complete, the *non-self-end type* that cannot end the action by itself, and the *non-end type* that cannot be stopped once started. An appropriate end or stop action must be performed for each type.

Operation No.	Name	Comment	Ending type
0	Test operation	Generates a 2.5Hz square wave position command signal for adjustment of the control part.	Non-self-end
1	Auto-tuning operation	Makes the rotor oscillate, measures load inertia and load mass, and sets the parameters for the control part automatically.	Self-end
2	(Reserved)		Self-end
3	Homing move	Finds the home position using the hardware over-travel signal, homing sensor, and motor Zero signal to establish the coordinate system.	Self-end
4	Program operation	Runs a program that was already registered.	Self-end
5	Signal search move	Moves the rotor until it reaches the set signal status and stops it when it reaches the status.	Self-end
6	(Reserved)		
7	MDI operation	Runs NC executable statements and parameter statement input from RC232C as soon as they are input.	Non-self-end
8	Index Type A operation	Performs index sense action based on equal division of the coordinate system. It can be used when the operation unit is set to index Type A.	Self-end
9	Index Type B operation	Performs index sense action based on unequal division of the coordinate system. It can be used when the operation unit is set to index Type B.	Self-end
10	Table reference operation	Refers to points set and performs positioning move.	Self-end
11 to 14	(Reserved)		
15	Mechanical setting mode	Special mode for changing mechanical setting parameters.	Non-end

### 5.3.1 Jog Move

The rotor can be moved in the positive (+) or negative (-) direction by issuing a jog move command while in idle status.

There are three types of jog move commands: (+) *direction move*, (-) *direction move*, and *stop*. Refer to the sections about the RS232C interface and PLC interface for how to issue a command.

The move can only be trapezoidal but it is possible to set the acceleration and deceleration profile. In addition, the velocity override does function in real time. The velocity in the jog move is determined by the value in the #10 *Jog Velocity* parameter.

If operation is started while the jog move is in progress, the operation is executed as soon as the jog move stops. The settling wait function is not performed at the end of the jog move.

### 5.3.2 Test Operation

This operation generates a 2.5Hz square wave and uses it as position command signal for adjustment of the control part. Set the analog monitor to *test operation response* to measure the response waveform on the oscilloscope.

The position feed forward, velocity feed forward, and acceleration feed forward are set to 0 internally during the test operation.

The settling wait function is not performed at the end of the test operation.

#### [Related parameters]

#31	Operation width under testing mode
#50	Position control bandwidth
#51	Velocity control bandwidth
#53	Position integral limiting value
#70	Analog monitor selection
#72	Test operation monitoring gain (analog monitor)

#### ⚠ Caution

- Obtain the fastest possible rise time of the response waveform and make adjustments so that overshoot will not occur.
- The closer the position control bandwidth and velocity control bandwidth are, the more the waveform will oscillate.
- If the inertia and weight of the load are large, the oscillations may be eliminated by setting the position integral limiting value to a small value.

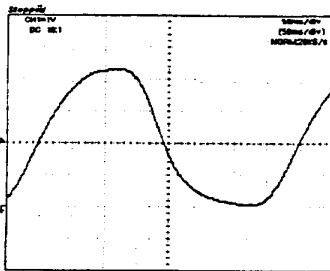

Increase the position control bandwidth.

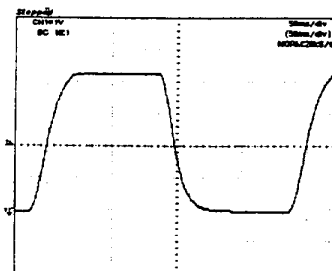

Make adjustments until this waveform is reached

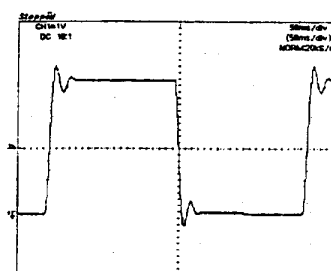

If the velocity control bandwidth cannot be increased any further, the position control bandwidth should be decreased.

### 5.3.3 Auto-Tuning Operation

This operation makes the rotor oscillate, measures the inertia and weight of the load, and automatically sets the parameters for the control part.

It accelerates/decelerates with half the rated torque and rated thrust of the motor, and measures the inertia and weight of the load from the velocity changes at that time. The result of the measurement is written to the #155 *Load inertia/load mass* parameter.

From the measured inertia and weight of the load, it adjusts the position control bandwidth, velocity control bandwidth, and position integral limiting value according to the setting value of the #38 *Servo stiffness settings* parameter. It does not adjust position feed forward, velocity feed forward, and acceleration feed forward.

The settling wait function is not performed at the end of the auto-tuning operation.

#### [Related parameters]

#32	Operation width under Auto-tuning
#33	Maximum deceleration under Auto-tuning
#34	Initializing the deceleration time while under Auto-tuning
#37	Auto-tuning repeat count
#38	Servo stiffness settings

#### [Auto-set parameters]

#50	Position control bandwidth
#51	Velocity control bandwidth
#53	Position integral limiting value
#155	Load inertia/load mass

### 5.3.4 Homing Move

In this operation the rotor is moved according to a preset home position search method in order to establish a coordinate system. After first moving to the home position determined by the proximity signal and motor Zero signal, it continues to move an amount further given in the **#29 Offset distance from the Home position** parameter's setting value. It then sets the drive coordinate command value to the value set in the **#30 Homing complete operation command value** parameter.

There are two ways to generate motor Zero signals (hardware and software Zero signals). The method used varies depending on the motor. See the explanation given below.

The homing operation is processed in the following order.

The move can only be trapezoidal but it is possible to set the acceleration and deceleration profile. In addition, the velocity override does function in real time.

The settling wait function is performed at each point during the homing operation.

#### [Related parameters]

#11	Over-travel search velocity during a homing move	[Hardware Zero signal]	
#12	Homing operation: Home sensor proximity signal search velocity	Applicable motor:	
#15	Homing operation: Origin position offset feed velocity	DYNASERV	
#20	Homing direction		DMA and DMB series
#21	Enable/Disable the over-travel signal under the homing mode	[Software Zero signal]	
#25	Homing operation: Origin inside selection	Applicable motor:	
#27	Enabling the homing flag position error	DYNASERV	
#29	Offset distance from the Home position		Flat motor (DM1004B)
#30	Homing complete operation command value		Small-diameter motor (DM1004C)
#202	Coordinates (+) direction setting		Standard DRA, DRB and DRE series
			High-speed DRB and DRE series

#### (1) OT search move

The rotor moves until it finds an over-travel (OT) signal in the opposite side of the homing direction and in the opposite direction of homing direction. It is executed only when the OT signal search move is enabled in **#21 Enable/Disable the over-travel signal under the homing mode** parameter.

The moving velocity is set to the value in **#11 Over-travel search velocity during a homing move** parameter.

#### (2) Homing search move

The rotor moves until it finds a homing sensor in the homing direction.

The moving velocity is set to the value in **#12 Homing operation: Home sensor proximity signal search velocity** parameter.

#### (3) Moving to outside of home position proximity area

If **#202 = 1**, the rotor moves in (+) direction until it is out of the home position proximity area. If **#202 = 0**, the rotor moves in (-) direction until it is out of the home position proximity area.

The moving velocity is determined internally by the driver.

#### (4) First home sensing move

If **#202 = 1**, the rotor searches and moves the home position proximity signal in (-) direction, identifies the first Zero signal edge as the home position upon entering the area, and then stops. If **#202 = 0**, the rotor searches and moves the home position proximity signal in (+) direction, identifies the first Zero signal edge as the home position upon entering the area, and then stops.

The moving velocity is determined internally by the driver.

With **#25 Homing operation: Origin inside selection**, whether the inside Zero signal in the home position proximity signal is set to the home position or the outside Zero signal is set to the home position can be selected. If **#25 = 1**, it is set to the inside; if **#25 = 0**, it is set to the outside.



## (5) Second home sensing move

The second home sensing move is executed in two steps.

## 1) Preparation move

The rotor moves as far as diametrically opposite the Zero signal edge in the opposite direction of the Zero signal edge search direction that was used in the first home sensing move.  
The moving velocity is determined internally by the driver.

## 2) Zero signal edge search move

The rotor moves until it finds the Zero signal edge in the Zero signal edge search direction that was used in the first home sensing move.  
The moving velocity is determined internally by the driver.

## (6) Home position move

The home position is moved to the detected Zero signal edge position. Motors that use software Zero signals further perform a second corrective move.  
The moving velocity is determined internally by the driver.

## (7) Home position offset move

The home position is moved for the distance given by the value set in #29 *Offset distance from the Home position* parameter, after which the operation coordination command value is set to the value given in #30 *Homing complete operation command value* parameter.  
The moving velocity is set to the value in #15 *Homing operation: Origin position offset feed velocity* parameter.

For the homing move to be completed normally, the distance between the home position proximity area and the Zero signal edge must be within a specific range based on the value of #358 *Z-phase signal pulse interval* monitor. The reference value differs depending on the method by which the Zero signal (hardware or software Zero signal) is generated.

At the first home sensing move, the distance to the first Zero signal edge after passing through the home position proximity area (pulse amount) has been measured and written in #318 *Homing operation: The measured value* monitor. If this value does not satisfy the equations below, an error or warning will occur. In that case, the home position proximity dog should be adjusted and the homing move should be performed again. Repeat these steps until the operation is completed normally.

## [Hardware zero signal type]

		# 318 value	<	0.05* # 358 value	error
0.05* # 358 value	≧	# 318 value	<	0.1 * # 358 value	warning
0.1 * # 358 value	≧	# 318 value	≧	0.7 * # 358 value	normal
0.7 * # 358 value	<	# 318 value	≧	0.75* # 358 value	warning
0.75* # 358 value	<	# 318 value			error

## [Software zero signal type]

		# 318 value	<	0.05* # 358 value	error
0.05* # 358 value	≧	# 318 value	<	0.1 * # 358 value	warning
0.1 * # 358 value	≧	# 318 value	≧	0.4 * # 358 value	normal
0.4 * # 358 value	<	# 318 value	≧	0.45* # 358 value	warning
0.45* # 358 value	<	# 318 value			error

- Operation example 1 -

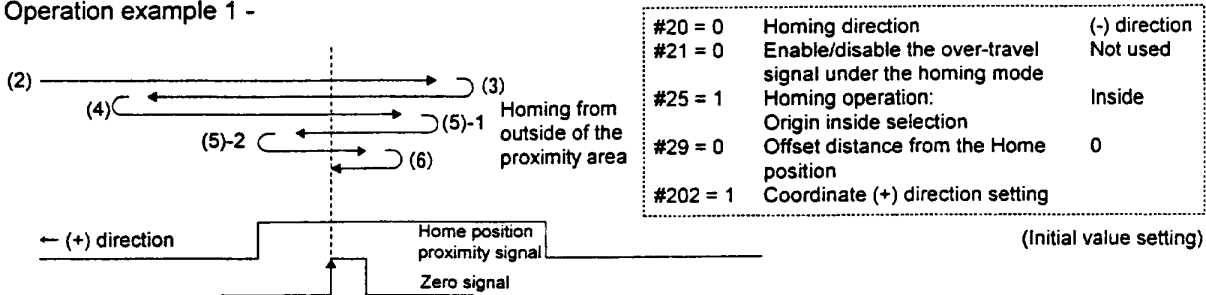

- Operation example 2 -

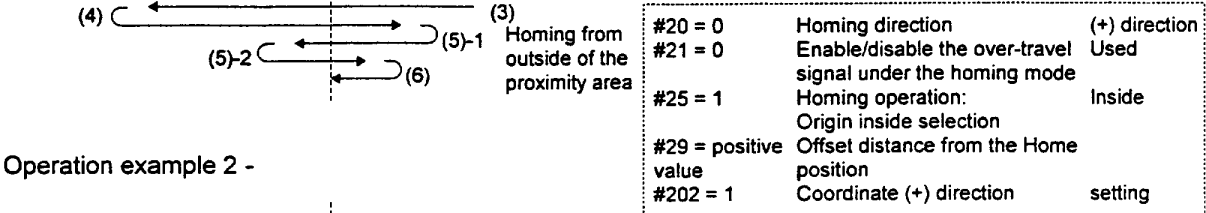

- Operation example 3 -

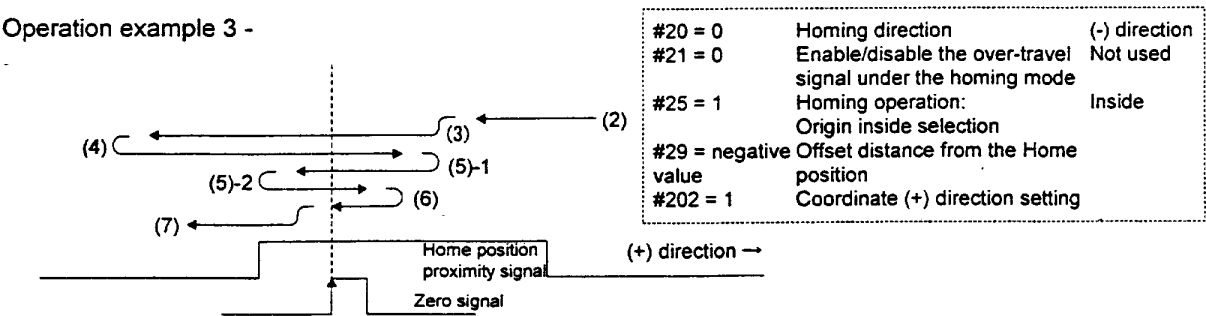

- Operation example 4 -

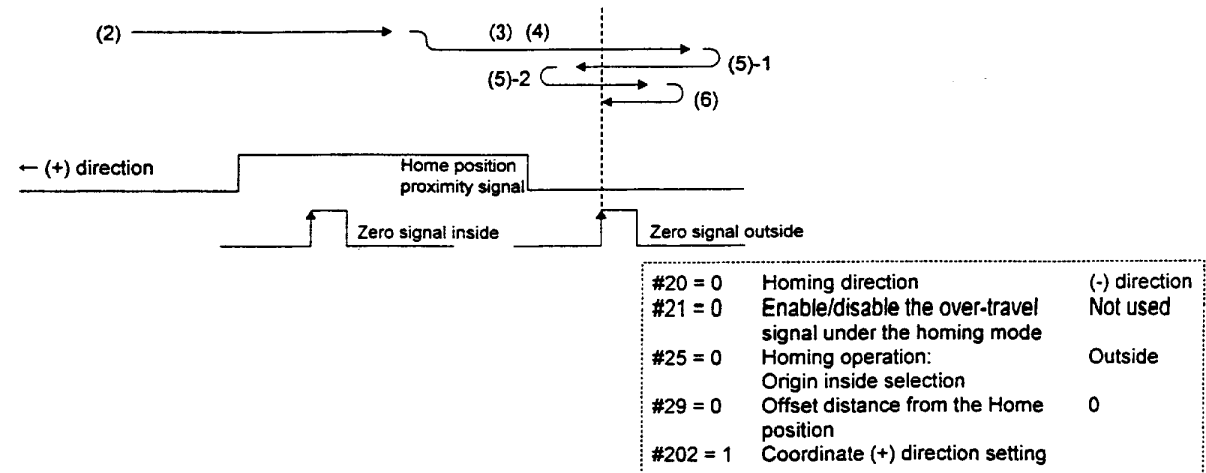

### 5.3.5 Program Operation

Program that have already been registered can be executed.

In a program, it is possible to use *parameter statements* to change parameters, *control parameters* for expressing branches and loops, and *comment statements* for explaining the program in addition to *NC executable statements* that directly operate the motor. Also, it is possible to call another program from a program as a subroutine.

A program can be registered by the PC utility. Refer to Chapter 7, "M2 PC Utility" for an explanation of how to register a program. Program properties can also be set for the program at registration. In doing so, an error check is performed according to the *program properties* when the program is executed.

Program can be registered as user programs numbered from 0 to 89. The capacity is 1000 blocks in total for user programs. Moreover, 10 programs are available from numbers 90 to 99 as built-in programs. The built-in programs cannot be overwritten.

The program with number 0 is a special program; it is started automatically when the power is turned on.

When the positioning operation is completed during program operation, the settling wait function is performed according to the *#106 Settling wait enable* parameter settings.

Note: The block number is the number of NC executable statements, parameter statements, control parameters, comment statements, etc. in the program. Normally one line makes up one block, but when a comment statement is added to an NC executable statement, parameter statement, or control parameter in one line, it is counted as two blocks.

#### (1) [Start-up options]

When starting a program operation, the action changes depending on which start-up option is given. Refer to Section 6.1, "RS232C Interface" and Section 6.2, "PLC Interface" for an explanation of the start-up options.

##### 1) Start-up option 1

Specify a program number. If a program number is not specified, the program whose execution program number is stored will be executed.

##### 2) Start-up option 2

Specify a block number. If a block number is not specified, the execution starts from the top line if a program number is specified, and the stored execution program line if a program number is not specified.

#### (2) [Step execution, repeat execution, program stop, and optional stop]

When step execution is enabled by *#82 Enabling the Program step execution* parameter, the operation finishes when one line is executed at each start-up. Thus, if the program is started repeatedly without specifying start-up options 1 and 2, it can be executed line by line.

When the last line of a program has been executed, the program will be executed from the first line again if *program auto-rewind* is enabled by the PLC interface.

The operation is stopped when M code 0 is executed in the program (*program stop*).

If optional stop is enabled with the *#103 Optional stop enable* parameter, the operation is stopped when the execution of M code 1 is completed in the program.

#### (3) [Program properties]

The following two items can be defined in the program properties. A program can then only be executed under conditions where each check box is enabled.

##### 1) Servo ready necessity

##### 2) Drive coordinate necessity

#### (4) [Start-up program]

If you register a program to program number 0, that program will be executed automatically when the power of the driver is turned on. This is convenient if you make a program that should always be performed after the power is turned on, such as a homing operation. This function can be switched between enabled and disabled by the #92 *Start-up program enable* parameter. When it is disabled, program number 0 is treated in the same way as programs with other program numbers.

##### [Related parameters]

#82	Enabling the program step execution
#83	ABS in program/MDI operation
#92	Start-up program enable
#100	M function enable in program/MDI operation
#103	Optional stop enable

### 5.3.6 Signal Search Move

This operation moves the rotor until the status reaches the preset signal status, and decelerates and stops when the status reaches the preset signal status.

There are three kinds of signals that can be set: (+) direction hardware over-travel signal, (-) direction hardware over-travel, and home position proximity signal. For each of them, it can be set whether to search for detection or for non-detection status. Moreover, if two or more signal detection are specified, the motor decelerates and stops when any one of the signals reaches the status in question.

The move can only be trapezoidal but it is possible to set the acceleration and deceleration profile. In addition, the velocity override does function in real time. The velocity during the signal search move is determined by the value in the #9 *feeding velocity* parameter.

After the signal search move is completed, the settling wait function is performed according to the setting of #106 *Settling wait enable* parameter.

##### [Related parameters]

#9	Feeding Velocity
#39	Signal search direction
#42	Enabling the proximity signal during homing
#43	Enabling the (+) direction over travel signal during the signal search mode
#44	Enabling the (-) direction over travel signal during the signal search mode
#47	Logic for the proximity signal during homing
#48	Logic for the (+) direction over-travel signal during the signal search mode
#49	Logic for the (-) direction over-travel signal during the signal search mode

### 5.3.7 MDI Operation

This operation runs *NC executable statement* and *parameter statement* input from RC232C as soon as they are input. Unlike the program operation, control parameters and comment statements cannot be executed.

After the positioning operation is completed by MDI operation, the settling wait function is performed according to the setting of #106 *Settling wait enable* parameter.

##### [Related parameters]

#83	ABS in program/MDI operation
#100	M function enable in program/MDI operation

### 5.3.8 Index Type A Operation

This operation performs an index sense action based on equal division of the coordinate system. It can be used only in a rotational coordinate system. It can be used when the operation unit selected by the #108 *Operation unit selection* parameter is set to *index Type A*.

The number of index points that the coordinate system should be divided into is determined by setting the #109 *Index Type A divisions setting* parameter. Refer to Section 5.4, "Coordinate System" for an explanation of the operation units, including how to set them.

In an index Type A operation it is possible to execute the M function after a positioning operation is completed by enabling the M function in the #101 *M function enable during index point operation* parameter. The M function takes the value of the operation command at the positioning location as its M code. Using this function, the host system can confirm the positioning location.

In addition to the trapezoidal move, a cam profile move can be used for the move. The velocity override does also function in real time. Refer to Section 5.5, "Acceleration/Deceleration Function" for details on how to determine the velocity and profile during the move.

After the index Type A operation is completed, the settling wait function is performed according to the setting of #106 *Settling wait enable* parameter.

#### (1) [Start-up option]

When starting an index Type A operation, the action changes depending on which start-up option is provided. Refer to Section 6.1, "RS232C Interface" and Section 6.2, "PLC Interface" for an explanation of how to give start-up options.

- 1) Start-up option 1  
Specify an index number. When the incremental instruction is performed, a value relative to the current operation command value is set, and when the absolute instruction is performed, the target operation command value is set. This number must be always set.
- 2) Start-up option 2  
Specify either an incremental instruction or an absolute instruction. If this is not specified, it is assumed that an incremental instruction is specified. However, if a start-up option dependence is not set in the #104 *ABS/INC setting during table index operation* parameter, the value specified becomes invalid.
- 3) Start-up option 3  
Specify a moving direction option. If this is not specified, it is assumed that Type 0 is specified as the moving direction type. However, if a start-up option dependence is not set in the #105 *Moving direction option for rotational coordinates* parameter, the value specified becomes invalid.

Note: Regarding the moving direction for rotational coordinates

Type0 Proximity rotational move (multiple rotations are not allowed).

Type1 Does not cross the rotational coordinate's home position (multiple rotations are not allowed).

Type2 Calculates the target position relative to the current rotational coordinate's home position and determines the direction (multiple rotations are allowed).

#### [Related parameters]

#101	M function enable during index point operation
#104	ABS/INC setting during table index operation
#105	Moving direction option for rotational coordinates
#108	Operation unit selection
#109	Index Type A divisions setting

### 5.3.9 Index Type B Operation

This operation performs an index sense action based on unequal division of the coordinate system. It can be used only in a rotational coordinate system. It can be used when the operation unit selected by the #108 *Operation unit selection* parameter is set to *index Type B*.

The number of index points that the coordinate system should be divided into is determined by setting the #110 *Index Type B divisions setting* parameter. Refer to Section, 5.4 “Coordinate System” for an explanation of the operation units, including how to set them.

In an index Type B operation it is possible to execute the M function after a positioning operation is completed by enabling the M function in the #101 *M function enable during index point operation* parameter. The M function takes the value of the operation command at the positioning location as its M code. Using this function, the host system can confirm the positioning location.

In addition to the trapezoidal move, a cam profile move can be used for the move. The velocity override does also function in real time. Refer to Section 5.5, “Acceleration/Deceleration Function” for details on how to determine the velocity and profile during the move.

After the index Type B operation is completed, the settling wait function is performed according to the setting of #106 *Settling wait enable* parameter.

#### (1) [Start-up option]

When starting an index Type B operation, the action changes depending on which start-up option is provided. Refer to Section 6.1, “RS232C Interface” and Section 6.2, “PLC Interface” for an explanation of how to give start-up options.

##### 1) Start-up option 1

Specify an index number. When the incremental instruction is performed, a value relative to the current operation command value is set, and when the absolute instruction is performed, the target operation command value is set. This number must be always set.

##### 2) Start-up option 2

Specify either an incremental instruction or an absolute instruction. If this is not specified, it is assumed that an incremental instruction is specified. However, if a start-up option dependence is not set in the #104 *ABS/INC setting during table index operation* parameter, the value specified becomes invalid.

##### 3) Start-up option 3

Specify a moving direction option. If this is not specified, it is assumed that Type 0 is specified as the moving direction type. However, if a start-up option dependence is not set in the #105 *Moving direction option for rotational coordinates* parameter, the value specified becomes invalid.

Note: Regarding the moving direction for rotational coordinates

Type0 Proximity rotational move (multiple rotations are not allowed).

Type1 Does not cross the rotational coordinate's home position (multiple rotations are not allowed).

Type2 Calculates the target position relative to the current rotational coordinate's home position and determines the direction (multiple rotations are allowed).

#### [Related parameters]

#101	M function enable during index point operation
#104	ABS/INC setting during table index operation
#105	Moving direction option for rotational coordinates
#108	Operation unit selection
#110	Index Type B divisions setting

### 5.3.10 Table Reference Operation

This operation references the points set, and performs the corresponding positioning move.

A point set item consists of a *value* (#600 to #699) and an *option* (#700 to #799). The point set (value) obtained by adding 600 to the specified table number is used as a target value or relative value for positioning and the corresponding point set (option) obtained by adding 700 is used as optional data for the moving method, etc. at positioning.

For details of points set, refer to Section 5.2.6, "Points Set (Value and Option)."

In addition to the trapezoidal move, a cam profile move can be used for the move. The velocity override does also function in real time. Refer to Section 5.5, "Acceleration/Deceleration Function" for details on how to determine the velocity and profile during the move.

After the table reference operation is completed, the settling wait function is performed according to the setting of #106 *Settling wait enable* parameter.

#### (1) [Start-up option]

When starting table reference operation, the action changes depending on which start-up option is provided. Refer to Section 6.1, "RS232C Interface" and Section 6.2, "PLC Interface" for an explanation of how to give start-up options.

##### 1) Start-up option 1

Specify a table number. The point set value and option are obtained based on this number. The point set value obtained is set as a value relative to the current operation command value in case of an incremental instruction, and as the target operation command value in case of an absolute instruction. This number must always be specified.

##### 2) Start-up option 2

Specify either an incremental instruction or an absolute instruction. If this is not specified, it is assumed that an incremental instruction is specified. However, if a start-up option dependence is not set in the #104 *ABS/INC setting during table index* operation parameter, the value specified becomes invalid.

##### 3) Start-up option 3

Specify a moving direction option. If this is not specified, it is assumed that Type 0 is specified as the moving direction type. However, if a start-up option dependence is not set in the #105 *Moving direction option for rotational coordinates* parameter, the value specified becomes invalid.

Note: Regarding the moving direction for rotational coordinates

Type0 Proximity rotational move (multiple rotations are not allowed).

Type1 Does not cross the rotational coordinate's home position (multiple rotations are not allowed).

Type2 Calculates the target position relative to the current rotational coordinate's home position and determines the direction (multiple rotations are allowed).

#### [Related parameters]

#104	ABS/INC setting during table index operation
#105	Moving direction option for rotational coordinates

### 5.3.11 Mechanical Setting Mode

This is a special mode for changing parameters related to the mechanical settings. Parameters #200 to #299 can be changed only when this operation is being executed. In addition, once started, this operation cannot be stopped. After you finish changing the necessary parameters, turn the power to the driver off and on again. Note that if you change these parameters, the changed values are not reflected until after the power is turned on again. Therefore, please note that if you try to read a parameter value after you change the parameter, the value before the change is read until you turn the power off and on again.

## 5.4 Coordinate System

The driver controls the position of the motor by three coordinate systems with different units: an *operation unit coordinate system*, a *command unit coordinate system*, and a *pulse coordinate system*.

The pulse coordinate system manages the coordinate values in units of pulses that can be detected by the encoder resolver. The position control part of the driver controls the motor based on these coordinate values. It has a command value and a current value, and they are always updated and displayed in the #320 *Pulse position command value* monitor and #321 *Pulse position current value* monitor, respectively.

The command unit coordinate system manages the coordinate values in command units specified by the user. The acceleration/deceleration control part of the driver performs computation based on these coordinate values. It has only command values, which are always updated and displayed in the #323 *Command unit command value* monitor.

The operation unit coordinate system is used for the positioning commands by the user. This coordinate system has only command values, which are updated and displayed in the #326 *Operation command value* monitor when the user makes positioning commands and coordinate system settings.

These coordinate systems can be used in two ways: rotational coordinates and linear coordinates. They are switched by the #212 *Straight line coordinate selection* parameter.

### 5.4.1 Scaling Conversion (Conversion from Command Units to Pulse Units)

The scaling of values can be converted by setting #208 *Command unit selection* parameter. The meaning hereof is not identical in the rotating type motor (DYNASERV) and linear motor (LINEARSERV) contexts. They are hereby explained separately.

In case of the rotating type (DYNASERV), the conversion works as follows with respect to the value set in #208. The value of the #324 *Scaling data (command unit side)* monitor is set as follows according to the setting of #208. The value of the #325 *Scaling data (pulse side)* monitor is set to the value of the #210 *Scaling data (pulse side)* parameter as it is regardless of the setting of #208.

#208	Function	#324	Remark
0	Pulse	#210	The command unit is given in pulse units that can be detected by the encoder/resolver as in the pulse coordinate system.
1	Angle (1/1000 degree unit)	360000	360 degrees correspond to #210. The command unit is 1/1000 degree.
2	Angle (1/100 degree unit)	36000	360 degrees correspond to #210. The command unit is 1/100 degree.
3	Scaling	#209	#209 corresponds to #210. The command unit is the value set in #209.
4	Angle (1/10000 degree unit)	3600000	360 degrees correspond to #210. The command unit is 1/10000 degree.

In case of the linear type (LINEARSERV), the conversion works as follows with respect to the value set in #208. The value in the #324 *Scaling data (command unit side)* monitor is set as follows according to the setting of #208. The value of #325 *Scaling data (pulse side)* monitor is set to the value of the #210 *Scaling data (pulse side)* parameter as it is regardless of the setting of #208.

#208	Function	#324	Remark
0	Pulse	#210	The command unit is given in pulse unit that can be detected by the encoder/resolver as in the pulse coordinate system.
1	Length (1 $\mu\text{m}$ unit)	1000000	1 m corresponds to #210. The command unit is 1 $\mu\text{m}$ .
2	Length (10 $\mu\text{m}$ unit)	100000	1 m corresponds to #210. The command unit is 10 $\mu\text{m}$ .
3	Scaling	#209	#209 corresponds to #210. The command unit is the value set in #209.
4	Length (0.1 $\mu\text{m}$ unit)	10000000	1 m corresponds to #210. The command unit is 0.1 $\mu\text{m}$ .

When converting command values given in command units to pulse units, if the conversion results become smaller than -2147483648 or larger than 2147483647, a coordinate system error occurs.

#### [Related parameters]

#208	Command unit selection
#209	Scaling data (command unit side)
#210	Scaling data (pulse side)



### 5.4.2 Conversion from Operation Units to Command Units

There are three types of operation units: *command unit*, *index Type A*, and *index Type B*. Switching among them can be done by setting the #108 *Operation unit selection* parameter. In a linear coordinate system, only command units can be used.

If a command unit is selected as operation unit, the unit of a positioning command becomes the command unit as it is.

If index Type A is selected as operation unit, the unit of the positioning command becomes the index point number obtained by equally dividing one rotation of rotational coordinates defined by #324 *Scaling data (command unit side)*. The number of divisions is set by the #109 *Index Type A divisions setting* parameter. The setting can be done in two ways: the number of divisions can be set directly (1 to 100) or indirectly by selecting an index compensation file that defines a compensation value for each index point (-1: index compensation file A, 0: index compensation file B). The range of divisions is 1 to 100 for both methods. Note that when index compensation file A or B is selected, the file must be registered to the driver, otherwise the positioning command cannot be made.

If index Type B is selected as operation unit, the unit of the positioning command becomes the index point number obtained by equally dividing one rotation of rotational coordinates defined by #324 *Scaling data (command unit side)*. The number of divisions is set by the #110 *Index Type B divisions setting* parameter. The setting is made indirectly by selecting an index Type B file that defines command unit command values for each index point (-1: index Type B file A, 0: index Type B file B). The range of divisions is 1 to 100 for both methods. Note also that the selected index Type B file must be registered to the driver, otherwise the positioning command cannot be made.

#### (1) [Index compensation file]

In an index compensation file, the number of index divisions and compensation data for each index point are registered. The unit of compensation data is command unit. Refer to Chapter 7, "DrvMII PC Utility" for how to register a file.

#### (2) [Index Type B file]

In an index Type B file, the number of index divisions and command unit command value data for each index point are registered. The command unit command value data should be given in command units. Refer to Chapter 7, "M2 PC Utility" for how to register a file.

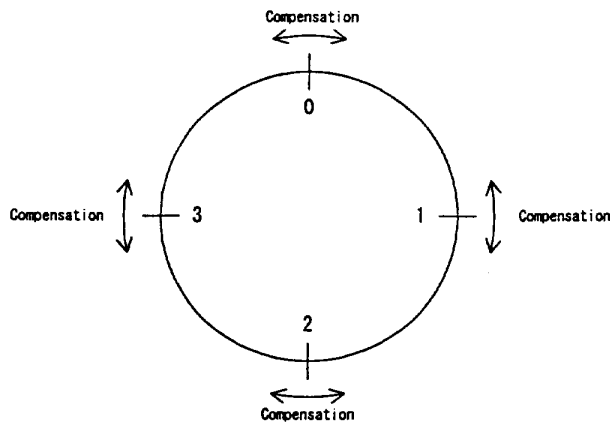

[Index compensation file image]

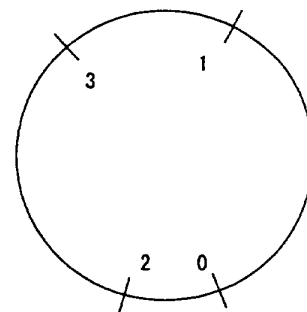

[Index Type B file image]

#### [Related parameters]

#108	Operation unit selection
#109	Index Type A divisions setting
#110	Index Type B divisions setting

### 5.4.3 Rotational Coordinates

In a rotational coordinate system, the command unit coordinate system and the pulse coordinate system are each normalized using the values found in the #324 *Scaling data (command unit side)* and #325 *Scaling data (pulse side)* monitors respectively as one full rotation. If the value in #325 is the same as the value found in the #355 *Motor resolution* monitor, the coordinate value after one rotor rotation is the same as the coordinate value before the rotation. In rotational coordinates, the coordination system does not overflow even if the rotor is kept rotating in the same direction. In addition, the software limit function available in linear coordinates is not provided.

In rotational coordinates, the following three *moving direction options for rotational coordinates* are available for determining the moving direction for a positioning move. The options are furthermore set as follows.

(1) [Moving direction for rotational coordinates]

- Type0 Proximity rotational move (multiple rotations are not allowed).
- Type1 Does not cross the rotational coordinate's home position (multiple rotations are not allowed).
- Type2 Calculates the target position relative to the current rotational coordinate's home position and determines the direction (multiple rotations are allowed).

(2) [Operation method and moving direction options for rotational coordinates]

Program operation, MDI operation

The moving direction is determined by the #105 *Moving direction options for rotational coordinates* parameter.

Table reference operation

The moving direction is determined by the #105 *Moving direction options for rotational coordinates* parameter.

If the setting value is "3," the moving direction is determined by a start-up option.

If the setting value is "4," the moving direction is determined by the point set.

Index Type A operation, index Type B operation

The moving direction is determined by the #105 *Moving direction options for rotational coordinates* parameter.

If the setting value is "3," the moving direction is determined by a start-up option.

[Related parameters]

#105	Moving direction options for rotational coordinates
------	---

### 5.4.4 Linear Coordinates

In linear coordinates, the range that commands can be given in is -999999999 to +999999999 command units. When a command value in command units exceeds this range during the operation, either a + or - direction soft over-travel error occurs regardless of the settings of the #85 *Enable the (+) direction soft limit error* and #86 *Enable the (-) direction soft limit error* parameters.

In linear coordinates, two software limit functions are available. Set the limit amounts in the #87 *(+) direction soft limit settings* and #88 *(-) direction soft limit settings* parameters, then enable the error for each direction in #85 and #86. By doing so, a soft over-travel error occurs when a command unit command value exceeds the specified range.

[Related parameters]

#85	Enable the (+) direction soft limit error
#86	Enable the (-) direction soft limit error
#87	(+) direction soft limit settings
#88	(-) direction soft limit settings

### 5.4.5 Operation Coordinates Unsettled Status

The operation coordinates unsettled status refers to a condition where the match between an operation command value and the command unit command value is lost. When the power is turned on, the status is unsettled. Incremental instruction is prohibited in unsettled status.

To recover from unsettled status to settled status, either of the following operations is required.

- Normal completion of homing move
- Coordination system settings
- Absolute instruction

Furthermore, when one of the following operations is performed the status becomes unsettled.

- Servo OFF
- Starting a jog move, homing move, and signal search move
- Stopping positioning move (including test operation, auto-tuning operation)
- Changing operation units
- Changing #109 *Index Type A divisions setting* parameter when operation unit is index Type A.
- Changing #110 *Index Type B divisions setting* parameter when operation unit is index Type B.

## 5.5 Acceleration/Deceleration Function

The velocity profile of the driver can largely be classified into *trapezoidal moves* and *cam profile moves*. In addition, it has a velocity override function for switching velocity during a move, which works in real time even during the move (*real time velocity override function*).

The maximum velocity of the motor is defined in #213 *Maximum velocity*, but is limited by the maximum velocity defined within the driver. The limited value is displayed in the #357 *Maximum velocity* monitor.

### 5.5.1 Velocity Override Function

Three values, the values in the #16 *Velocity override percentage 1* and #17 *Velocity override percentage 2* parameters, and 0, are selected for the velocity override value by the PLC interface. Refer to Section 6.2, "PLC Interface" for how to select them. Of course, if the values of #16 and #17 are directly changed, the velocity override value is changed when the values are selected.

The velocity override value can be set in increments of 0.01% from 0 to 200%. Please note that if a value greater than 100% is set, the velocity during the move may exceed the maximum velocity, which may cause an error. How the velocity override is applied differs for the trapezoidal move and cam profile move.

[Related parameters]

#16	Velocity override percentage 1
#17	Velocity override percentage 2

### 5.5.2 Trapezoidal Motion Profile

In a trapezoidal motion, the acceleration of the moving part follows the acceleration type set by the #4 *Selecting acceleration type* parameter until it reaches the feed velocity. Hereafter, the move is continued with the feed velocity, then decelerates and stops according to the deceleration type set by the #5 *Selecting deceleration type* parameter. By default, the feed velocity is equal to the velocity set by the #9 *Feeding Velocity* parameter. The acceleration and deceleration types can be selected separately. There are two options for acceleration and deceleration: a *constant acceleration type* and an *S-shaped type* (where the acceleration/deceleration follows a second order spline). Generally, the S-shaped type can limit vibrations in the machine better, but the peak torque or peak thrust at acceleration/deceleration become greater and a correspondingly larger motor torque or motor thrust will be required.

The acceleration/deceleration time can also be selected separately. The values of the #7 *Acceleration time during a trapezoidal move* and #8 *Deceleration time during a trapezoidal move* parameters are set to values equivalent to the maximum velocity shown in the #357 *Maximum velocity* monitor. The actual acceleration/deceleration time becomes the value obtained by multiplying the maximum velocity by the velocity ratio during a trapezoidal move. By doing so, the same acceleration can be maintained without changing #7 and #8 even when the velocity setting is changed at a positioning command.

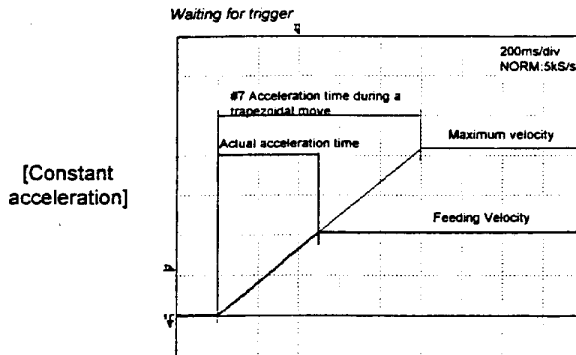

[Acceleration]

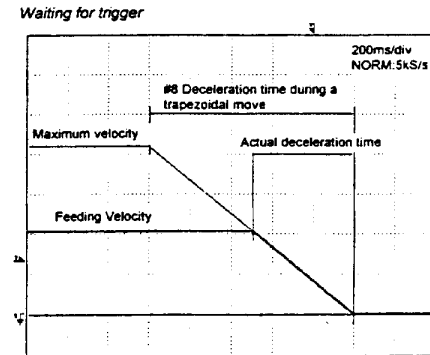

[Deceleration]

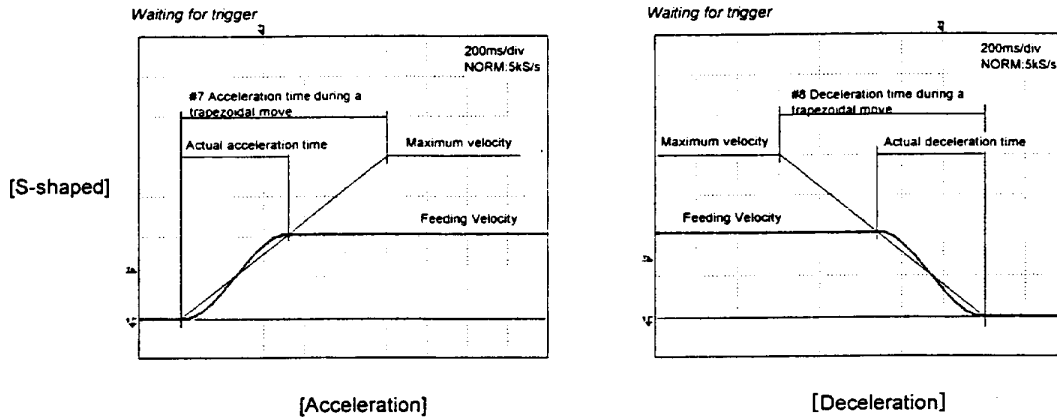

The feed velocity during a move becomes the commanded velocity multiplied by the velocity override value. If the velocity override value is changed during a move, the moving part is accelerated at the same acceleration profile and acceleration as the normal acceleration time when the velocity override value is increased. In the same way, the moving part is decelerated at the same deceleration profile and deceleration as the normal deceleration time when the velocity override value is decreased.

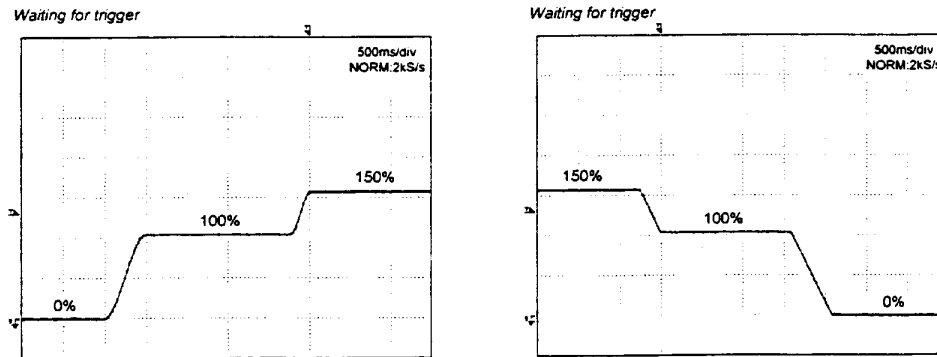

[Related parameters]

- #3 Selecting the type of cam profile move
- #4 Selecting the acceleration type
- #5 Selecting the deceleration type
- #7 Acceleration time during a trapezoidal move
- #8 Deceleration time during a trapezoidal move

### 5.5.3 Cam Profile Move

In a cam profile move, the acceleration/deceleration is performed according to the cam profile set by #6 Selection of the cam profile parameter.

If the #84 Enabling the peak velocity during a cam profile move parameter is enabled during a cam profile move, the moving part is accelerated/decelerated so that the maximum velocity during the move becomes the commanded feed velocity. If it is disabled, the moving part is accelerated/decelerated so that the move time becomes the value of the #79 Move time during a cam profile selection parameter. At this point, if the move time setting is short enough to make the maximum velocity during the move exceeds the maximum velocity, the move time is extended so that the maximum velocity during the move becomes equal to the maximum velocity. The cam profile can be chosen from eight standard built-in cam profiles, as well as from eight user registered cam profiles. Refer to Chapter 7, "M2 PC Utility" for how to create and register a user registered cam profile.

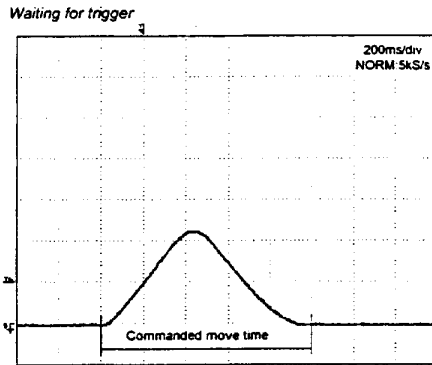

[Cam profile specified by move time]

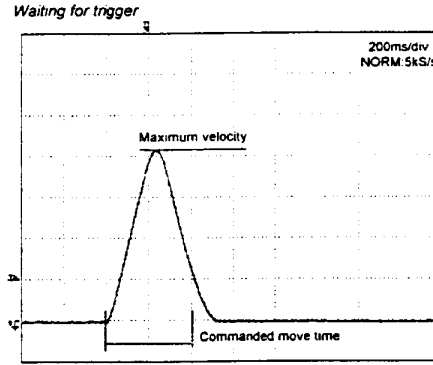

[Cam profile specified by move time]  
Limited by the maximum velocity

The velocity override value acts as a ratio by which the elapsed time in the acceleration/deceleration control is multiplied. In other words, if the commanded move time is 1000msec and the velocity override value is 200% the move is finished at 500msec, and if the velocity override value is 50% the move is finished at 2000msec. If the velocity override value is changed during a move, the velocity override value within the driver to which the acceleration/deceleration control refers is updated gradually. If the velocity override value is changed to a bigger value, the value of the #80 Acceleration time during a cam profile selection parameter is used to update the velocity override value within the driver. If it is changed to a smaller value, the #81 Deceleration time during a cam profile selection parameter is used. Since both values are defined as a time equivalent by which to change the velocity override value at 100%, the actual change time changes according to the amount of velocity override change.

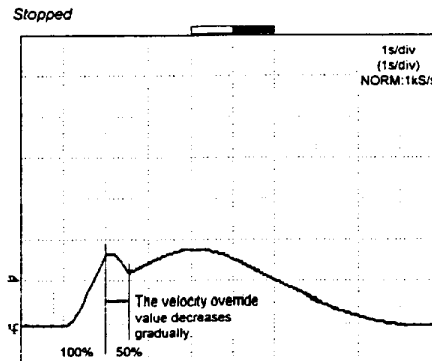
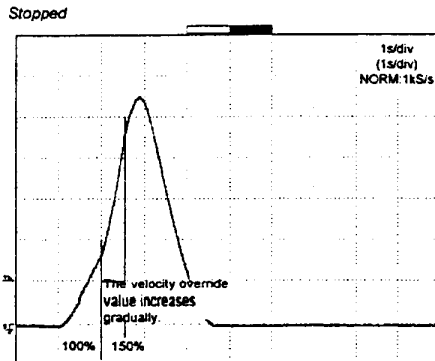

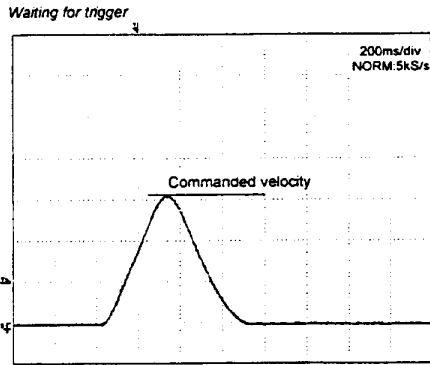

[Cam profile specified by peak velocity]

[Standard built-in cam profile]

Number	Name	Non-dimensional maximum velocity Vmax	Non-dimensional minimum velocity Vmin	Non-dimensional starting velocity Vs	Non-dimensional terminal velocity Ve	Non-dimensional maximum acceleration Amax	Non-dimensional minimum acceleration Amin
1	Constant velocity	1.000000	1.000000	1.000000	1.000000	0.000000	0.000000
2	Constant acceleration	2.000000	0.000000	0.000000	2.000000	2.000000	2.000000
3	Second order spline	2.000000	0.000000	0.000000	2.000000	3.000000	0.000000
4	Sinusoidal curve	1.570796	0.000000	0.000000	0.000000	4.934803	-4.934803
5	Cycloid	2.000000	0.000000	0.000000	0.000000	6.283184	-6.283184
6	Trapezoid curve	2.182160	0.000000	0.000000	0.000000	6.170441	-6.170441
7	Modified sinusoidal curve	1.759603	0.000000	0.000000	0.000000	5.527958	-5.527958
8	Modified trapezoid	2.000000	0.000000	0.000000	0.000000	4.888123	-4.888123

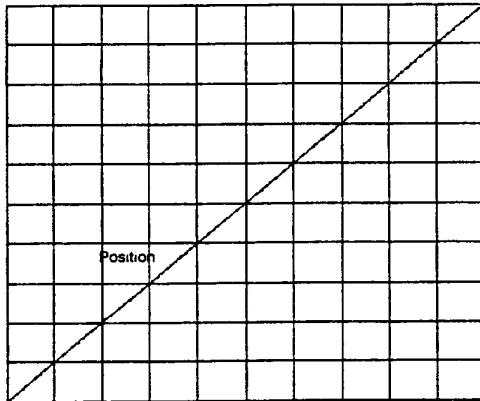

[1 Constant velocity]

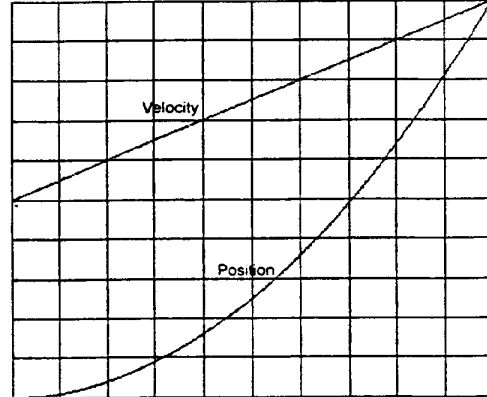

[2 Constant acceleration]

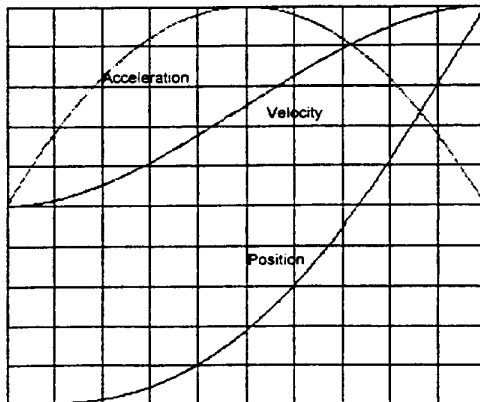

[3 Second order spline]

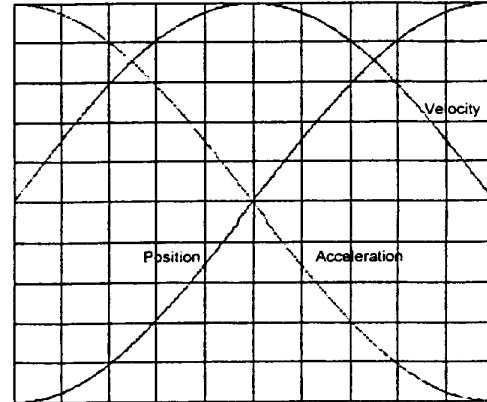

[4 Sinusoidal curve]

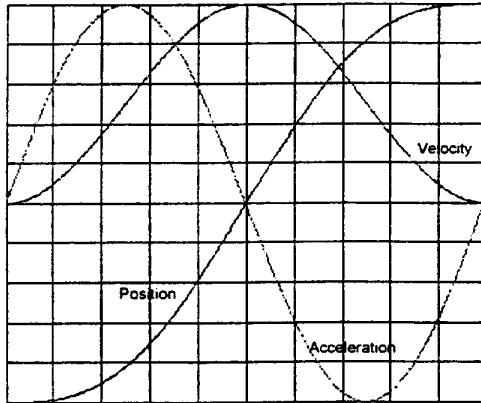

[5 Cycloid]

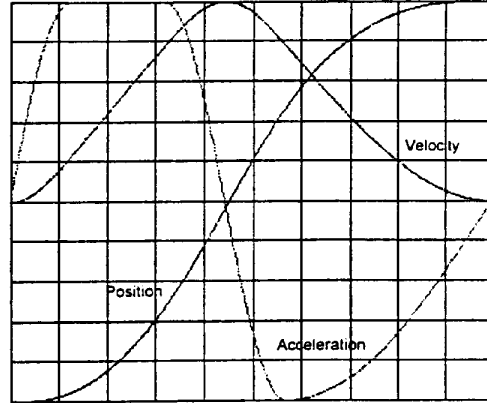

[6 Trapezoid curve]

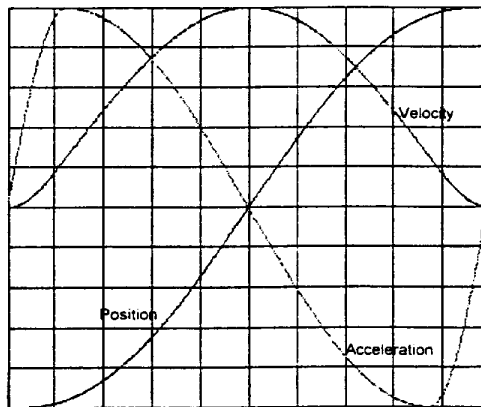

[7 Modified sinusoidal curve]

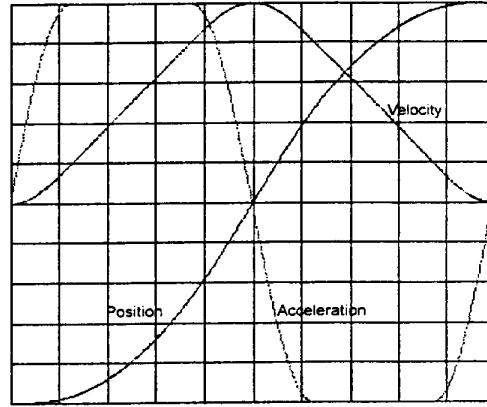

[8 Modified trapezoid]

[Related parameters]

- #3 Selecting the type of cam profile move
- #6 Selection of the cam profile
- #79 Move time during a cam profile selection
- #80 Acceleration time during a cam profile selection
- #81 Deceleration time during a cam profile selection
- #84 Enabling the peak velocity during a cam profile move



## 5.6 Programming Language

The programming language is a language used by program operation and MDI operation. In this section, the language specification is explained.

The programming language statements are classified into four types: *NC executable statements*, *parameter statements*, *control parameters*, and *comment statements*. Among them, the control parameters and comment statements cannot be used in MDI operation.

### 5.6.1 NC Executable Statements

An NC executable statement expresses an action with a combination of one English character and one or more numerical values. In addition to direct numerical values, the numerical value part of the statement may contain parameter/monitor variables referred to by *###*.

All the English characters may only appear once in one line. Furthermore, only one of the characters "F," "A," "f," or "a" may appear in one line.

(1) [G] preparation function

Group 0 (not stored)

- G04 dwell  
Waits for the amount of time specified.  
Usage → G04f### (### is the dwell time [msec])
- G27 hardware homing  
Performs a homing operation.  
Usage → G27X
- G28 software homing  
Moves to the home position of the operation unit coordinate system.  
Usage → G28X
- G92 coordinate system setting  
Sets the operation unit coordinate value to a specified value.  
Usage → G92X### (### is the operation unit coordinate value)

Group 1 (stored)

- G00 positioning  
Sets the operation unit coordinate value to a specified value.  
Usage → G00X### (### is the positioning value, the target value in an absolute instruction and the relative value in an incremental instruction)

Group 2 (stored → saved in #83 ABS in program/MDI operation)

- G90 absolute instruction  
Sets the operation to absolute instruction mode  
Usage → G90
- G91 incremental instruction  
Sets the operation to incremental instruction mode  
Usage → G91

(2) [X] axis specification

Specifies an axis. The expression method changes depending on the preparation function.

Usage

- Positioning X\*\*\* (\*\* is the positioning value [operation unit])
- Coordinate system setting X\*\*\* (\*\* is the operation unit coordinate value [operation unit])
- Hardware homing, software homing X (simply an axis specification)

(3) [F, A] velocity specification

Specifies the feeding velocity. The #9 feeding velocity parameter is changed. Also, when a cam profile move is selected in the #3 selecting the type of cam profile move parameter, #84 enabling the peak velocity during a cam profile parameter is changed to enabled.

- Usage → F\*\*\* (\*\* is the feeding velocity [command unit/sec])
- A\*\*\* (\*\* is the feeding velocity [command unit/sec])

(4) [f, a] time specification

Specifies time. In a positioning move, the #79 move time during a cam profile selection parameter is changed. Also, when a cam profile move is selected in the #3 selecting the type of cam profile move parameter, the #84 enabling the peak velocity during a cam profile parameter is changed to disabled. Moreover, only f can be used in the dwell status.

- Usage → f\*\*\* (\*\* is time [msec]), a\*\*\* (\*\* is time [msec])

(5) [M] signal code for external devices

Specifies the value of the M function, which is used as a signal code for external devices. M code 0 and 1 have special meaning.

- M code 0 Program stop
- M code 1 Optional stop
- Usage → M\*\*\* (\*\* is M code 0 to 99)

### 5.6.2 Parameter Statements

In a parameter statement, it is possible to assign numerical values and variables (*simple assignment statement*) and assign results of arithmetic operations on numerical values and variables (*calculation result assignment statement*) to parameters. The left side must be a variable. The right side can contain numerical values or variables such as values in parameters/monitors referred to by #\*\*\*.

[Simple assignment statement]

- |             |  |
|-------------|--|
| #400 = 100  | Assigns 100 to variable #400.                      |
| #400 = #401 | Assigns the value stored in #401 to variable #400. |

[Calculation result assignment statement]

The following operands can be used:

- + Addition
- Subtraction
- \* Multiplication
- / Division
- % Remainder at integer division

- |                   |   |
|-------------------|---|
| #400 = 100 + 200  | Assigns the result of adding 100 and 20 to variable #400.   |
| #400 = #401 - 20  | Assigns the value obtained by subtracting 20 from the value stored in #401 to variable #400.                  |
| #400 = 100 * #401 | Assigns the result of multiplication of 100 and the value stored in #401 to variable #400.                    |
| #400 = #400/#401  | Assigns the value obtained by dividing the value stored in #400 by the value stored in #401 to variable #400. |
| #400 = 100%30     | Assigns the remainder of 100 divided by 30 to variable #400.  |

## 5.6.3 Control Parameters

Control parameters control the entire flow of a program. By using these statements, branches (IF statements) and loops (WHILE and FOR statements) can be built into the program.

The following relational operators can be used.

<	The left-side value is smaller than the right-side value.
<=	The left-side value is equal to or smaller than the right-side value.
>	The left-side value is greater than the right-side value.
>=	The left-side value is equal to or greater than the right-side value.
=	The left-side value is equal to the right-side value.
!=	The left-side value is not equal to the right-side value.

The maximum nesting depth that can be achieved with the control parameters is 15.

## (1) [IF statements] IF, ELSEIF, ELSE, END

The format is as shown below. The variable part must be a variable referred to by #\*\*\*. The relational operator part must be one of the relational operators described above. The comparison data part can be numerical values or variables referred to by #\*\*\*.

Note that the ELSEIF and the ELSE statements may be omitted.

```
IF:variable:relational operator:comparison data
ELSEIF:variable:relational operator:comparison data
ELSE
END
```

## [Example]

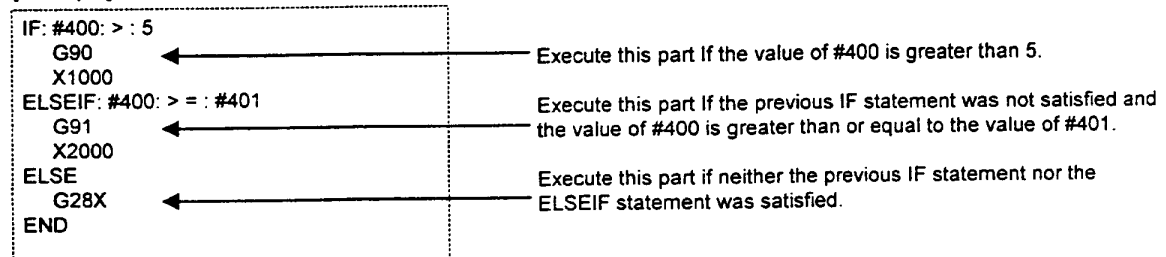

## (2) [WHILE statements] WHILE, END

The format is as shown below. The variable part must be a variable referred to by #\*\*\*. The relational operator part must be one of the relational operators described above. The comparison data part can be numerical values or variables referred to by #\*\*\*.

The WHILE statement performs a condition check and executes the block if the condition is true. After the block is executed, it checks the condition again. If the condition remains true, it executes the block again. If the condition is not true, it jumps to the next line after the END statement.

```
WHILE:variable:relational operator:comparison data
END
```

## [Example]

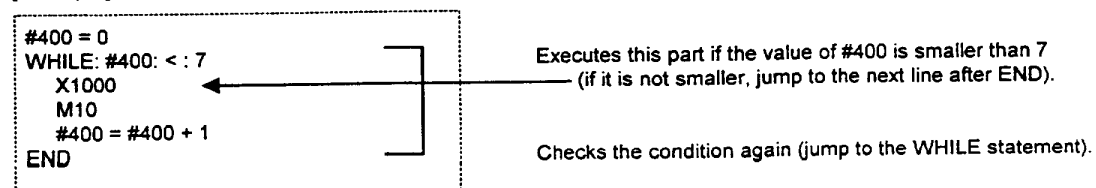

### (3) [FOR statements] FOR, END

The format is as shown below. The variable part must be a variable referred to by #\*\*\*. The relational operator part must be one of the relational operators described above. The initial value, comparison data, and step number parts can be numerical values or variables referred to by #\*\*\*.

In a FOR statement, the initial value is assigned to the variable first. Secondly, a condition check is performed and the block is executed if the condition is true. After executing the block, the step number is added to the variable and the condition is checked again. If the condition remains true, the block is executed again. If the condition is not true, the program jumps to the next line after the END statement.

FOR:variable:initial value:relational operator:comparison data:number of steps  
END

#### [Example]

```
FOR: #400: 0: < : 7:1  
  X1000  
  M10  
END
```

This example expresses the WHILE statement example shown in the previous example using a FOR statement instead.

### (4) [P] program call

This statement calls other programs. The nesting depth (i.e., the number of other programs called from a program) can be up to 15.

Usage → P\*\*\* (\*\* is program number between 0 and 99)

The following shows a program example using only NC executable statements.

```
G27X  
G04f1000  
G92X90000  
G90  
X180000F90000  
G91X-180000  
F#400  
G90X#401  
G04#400  
G28X
```

Hardware homing  
1000msec wait  
Sets the current position to operation unit coordinate value 9000.  
Sets the operation to absolute instruction mode.  
Positioning move at a velocity of 90000 to operation unit coordinate value 180000  
Switches to incremental instruction mode, and make a positioning move to a position -180000 from the current position.  
Sets the feeding velocity to the value set in #400.  
Switches to absolute instruction mode, and make a positioning move to the position given by the value in #401.  
Waits for a time equal to the value in #401.  
Software homing

## 5.6.4 Comment Statements

Comment statements are used to explain a program. Note that only half-width characters can be used. Up to 40 characters can be registered.

One comment statement can form one line by itself, or it can be attached after an NC executable statement, parameter statement, or control parameter.

[ ]

All characters after a single quotation mark [ ' ] are treated as comments.

#### [Example]

```
This is comment.  
G90 'This is comment.  
#400=100 'This is comment.
```

An independent comment statement.  
A comment statement combined with an NC executable statement.  
A comment statement combined with a parameter statement.

### 5.6.5 Explanation of Built-in Programs

The driver contains the 10 built-in programs numbered 90 to 99. This part is fixed and cannot be overwritten. In this section, the built-in programs are introduced and explained so that you may use to reference them as program examples.

90	In case of a rotating motor	Index Type A demo.
	In case of a linear motor	Reciprocating operation demo.
91	In case of a rotating motor	Reserved
	In case of a linear motor	Reciprocating operation demo.
92 to 94	(Reserved)	
95	Coordinate system clear	
96	Store the current position	
97	Move to a stored position	
98 to 99	(Reserved)	

(1) No. 90 (for a rotating motor) index Type A demo.

This program is executed when #210 (scaling data pulse count) remains as the initial value and a rotational coordinate system is used.

The operation unit is set to index Type A and divided into eight (equal divisions).

It moves the rotor step by step in the positive direction, eight times in total, and then two steps at a time in the negative direction four times in total. This process is repeated five times.

The positioning moves are performed as cam profile (trapezoid) moves. After each positioning, the rotor dwells for 500ms or 200ms.

```

Rotating motor: index Type A demo.
IF:#210==:#355 'Only when the scaling pulse value is the same as the resolution
IF:#212==:0 'Only in rotational coordinates
#109=8 'Set to Index A 8 divisions
#108=1 'Set the operation unit to index A
#3=1 'Cam profile move
#6=6 - 'Trapezoid
G92X0 'Clear the coordinate system
FOR:#549:0:<:5:1 'Repeat 5 times
  FOR:#548:1:<=#109:1 'Step by step in + direction
    G90X#548f500 'Move for 500ms
    G04f500 'Dwell for 500ms
  END
  #547=#109-2 'Store 6 in #547
  FOR:#548:#547:>=:0:-2 'Two steps at a time in - direction
    G90X#548f1000 'Move for 1000ms
    G04f200 'Dwell for 200ms
  END
END
END
END
END

```

(2) No. 90 (for a linear motor) reciprocating operation demo.

This program is executed when #210 (scaling data pulse count) remains as the initial value. Make sure not to execute the program until after setting the slider at the center of the stroke. It moves the motor 10cm in the positive direction twice and returns to the starting position, then moves 10 cm in the negative direction twice and returns to the starting position. This process is repeated five times. The positioning moves are performed as trapezoid moves. After each positioning, the motor dwells for 200 ms, 500 ms or 1s.

```
Linear motor: demo
IF:#210:==:#355 'Only when the scaling pulse value is same as the resolution
#108=0 'Set the operation unit to index A
#3=0 'Trapezoidal move
#9=#213/10 'The moving velocity is 10% of the maximum
velocity
#546=#324/10 'Value equivalent to 10cm
#547=0-#546 'Value equivalent to -10cm
G92X0 'Clear coordinate system
FOR:#549:0:<:5:1 'Repeat 5 times
G91X#546 '10cm INC move
G04f200 'Dwell for 200ms
G91X#546 '10cm INC move
G04f200 'Dwell for 200ms
G90X0 'To the original position
G04f500 'Dwell for 500ms
G91X#547 '-10cm INC move
G04f200 'Dwell for 200ms
G91X#547 '-10cm INC move
G04f200 'Dwell for 200ms
G90X0 'To the original position
G04f1000 'Dwell for 1s
END
END
```

(3) No. 91 (for a linear motor) reciprocating operation demo.

This program is executed when #210 (scaling data pulse count) remains as the initial value. Make sure not to execute the program until after setting the slider at the center of the stroke. It moves the motor 10cm in the positive direction twice and returns to the starting position, then moves 10cm in the negative direction twice and returns to the starting position. This process is repeated five times. The positioning moves are performed as trapezoid moves. After each positioning, the motor dwells for 200ms, 500ms or 1s.

```
Linear motor: demo
IF:#210:==:#355 'Only when the scaling pulse value is same as the
resolution
#108=0 'Set the operation unit to command unit
#3=0 'Trapezoidal move
#9=#213/10 'The moving velocity is 10% of the maximum velocity
#546=#324/10 'Value equivalent to 10cm
#547=0-#546 'Value equivalent to -10cm
G92X0 'Clear coordinate system
FOR:#549:0:<:5:1 'Repeat 5 times
G91X#546 '10cm INC move
G04f200 'Dwell for 200ms
G91X#546 '10cm INC move
G04f20 'Dwell for 200ms
G90X0 'To the original position
G04f50 'Dwell for 500ms
G91X#547 '-10cm INC move
G04f200 'Dwell for 200ms
G91X#547 '-10cm INC move
G04f20 'Dwell for 200ms
G90X0 'To the original position
G04f1000 'Dwell for 1s
END
END
```

## (4) No. 95 coordinate system clear

This program sets the current position to the home position of the operation unit coordinate system. It can be operated regardless of the value of the operation unit selection (#108).

```
G92X0          'Clear coordinate system
```

## (5) No. 96 store current position

This program stores the current command unit command value to the storage variable #449.

```
#449=#323     'Store command unit command value
```

## (6) No. 97 move to a stored position

This program moves to the position stored in program No. 96. It can be executed only when the operation unit selection (#108) is set to command units.

```
IF:#108::=0   'Restore stored position
G90X#449      'Only when the operation unit is 0
              'Move to the position stored in #449
END
```

## 5.7 M Function

The M function expresses the execution status of the driver in numerical values called *M codes*, and notifies them to the above layer (RS232C interface and PLC interface). The M function can be used in *program operation*, *MDI operation*, *index Type A operation*, and *index Type B operation*.

In program operation and MDI operation, it is possible by giving a command of the form "M\*\*" (where \*\* is a numerical value or variable) in an NC executable statement, to notify the numerical value or variable value expressed as \*\* to the above layer as an M code. Values from 0 to 99 can be notified. M codes 0 and 1 have special meanings in program operation. M code 0 has a *program stop* function and M code 1 has an *optional stop* function. For the detail of each, refer to Section 5.3.5, "Program Operation."

In index Type A and B operations, the operation command value at the positioning location is notified to the top as an M code.

### [Related parameters]

```
#100 M function enable in program/MDI operation
#101 M function enable during index operation
#102 Enabling the selection of RS232C for the M
      function interface
#103 Optional stop enable
```

## 5.8 Control System

In this section, the position control part, velocity control part, and feed forward of the driver are explained. The block diagram of the control system is shown below.

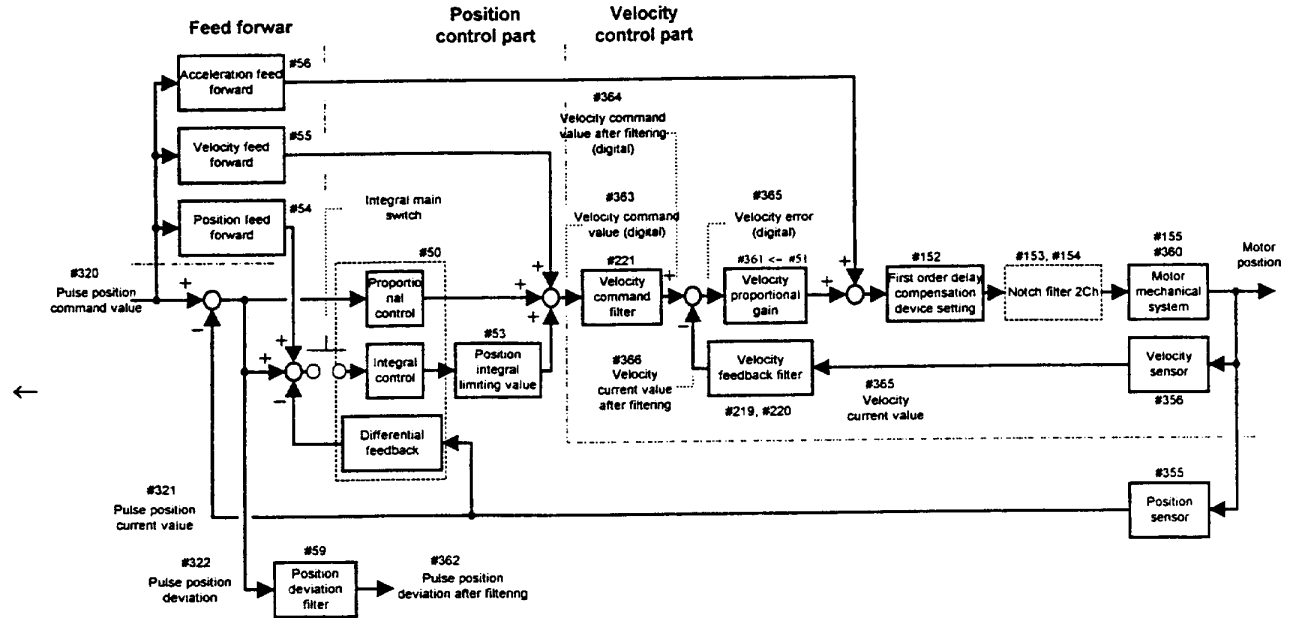



### 5.8.1 Velocity Control Part

The velocity control part calculates the #361 *Velocity proportional gain* monitor value from the #155 *Load inertia/load mass* parameter value, which is measured and set by the auto-tuning operation or set directly as a numerical value, according to the #51 *Velocity control bandwidth* parameter value. At this point, the notch filter frequency characteristics are not considered but the frequency characteristics of the velocity feedback filter and first order delay compensation device are considered in the calculation of the velocity proportional gain. The first order compensation device can be set in four ways via the #152 *First order delay compensation device setting* parameter. The first order delay compensation device has the effect that it improves the gain characteristics of the velocity control part. The frequency characteristics for each setting of the first order compensation device is shown below. Note that there is no frequency dependency when the first order compensation is not set.

There are two channels available for the notch filter (optional). The central frequency value can be set independently for each channel via the #153 *Notch filter: Frequency selection 1* and #154 *Notch filter: Frequency selection 2* parameters. The notch filter has the effect that it improves the gain characteristics of mechanical systems that tend to resonate.

The velocity feedback filter can be enabled or disabled by setting the #219 *Enable/Disable velocity feedback filter* parameter. When enabled, the filter bandwidth can be set in the #220 *Velocity feedback filter bandwidth* parameter. The velocity feedback filter is effective in eliminating noise at motor operation, but with a small bandwidth the velocity control part tends to oscillate.

The filter bandwidth of the velocity command filter can be set in the #221 *Velocity command filter bandwidth* parameter. The velocity command filter helps achieving smoother acceleration/deceleration, but with a small bandwidth the position control part tends to oscillate.

#### [Related parameters]

#51	Velocity control bandwidth
#152	First order delay compensation device setting
#153	Notch filter: Frequency selection 1
#154	Notch filter: Frequency selection 2
#155	Load inertia/load mass
#219	Enable/Disable velocity feedback filter
#220	Velocity feedback filter bandwidth
#221	Velocity command filter bandwidth

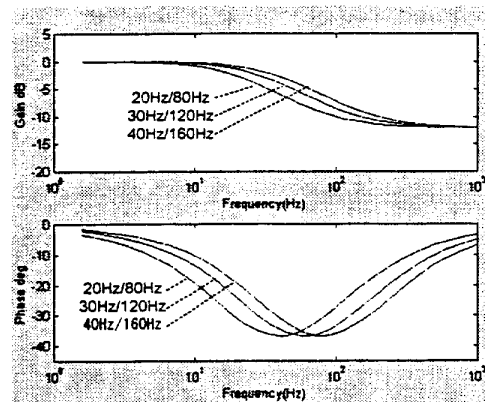

[Frequency characteristics of the first order delay compensation device]

## 5.8.2 Position Control Part

The position control part calculates the proportional control gain, integral control gain, and differential feedback gain based on the #50 *Position control bandwidth* parameter value.

The position integral limiter set by the #53 *Position integral limiting value* parameter is effective in suppressing integrator windup due to motor torque and thrust saturation. Decrease the value in order to suppress windup further. On the other hand, if you set the value too small, the motor torque and thrust are limited; set a value as large as possible in the range where windup does not occur.

The integral operation of the position control part can also be set either to be active (allow) or inactive (prohibit). If you clamp the motor with an external device when the motor is stopped, the integral operation should be prohibited after clamping in order to prevent overloading the controller. Refer to Section 6.1, “RS232C Interface” and Section 6.2, “PLC Interface” for details of the operation.

Though not related directly to the position control part, the position deviation filter outputs the result of filtering the position deviation to the #362 *Pulse position deviation after filtering* monitor. The filter bandwidth can be set in the #59 *Position deviation filter frequency* parameter. The filter output can be used as a signal source when generating a position settling status signal. For details about this, refer to Section 5.9.1, “Settling Wait, Position Settling Status, and Positioning Status.”

### [Related parameters]

#50	Position control bandwidth
#53	Position integral limiting value
#59	Position deviation filter frequency

## 5.8.3 Feed Forward

Three types of feed forward functions are available: position feed forward, velocity feed forward, and acceleration feed forward. Feed forward function is effective for quick positioning.

The position feed forward can be set by percentage in the #54 *Position feed forward percentage* parameter. The position feed forward makes the position deviation at equal velocity move smaller and helps to achieve a smooth settling at acceleration/deceleration.

The velocity feed forward can be set by percentage in the #55 *Velocity feed forward percentage* parameter. The acceleration feed forward calculates the acceleration feed forward gain from the #155 *Load inertia/load mass* parameter values, which are measured and set by the auto-tuning operation or set directly by numerical values, based on the #56 *Acceleration feed forward gain* parameter. #56 parameter is given as a percentage.

### [Related parameters]

#54	Position feed forward percentage
#55	Velocity feed forward percentage
#56	Acceleration feed forward percentage
#155	Load inertia/load mass

## 5.8.4 Servo Stiffness Parameter

The #38 *Servo stiffness settings* parameter is for general settings for the control system. The control parameters are set based on this parameter after measuring the load inertia/load mass in the auto-tuning operation.

If #38 is changed, the position control bandwidth (#50) and the velocity control bandwidth (#51) are set, so the gain of the control system is automatically set. The position integral limiting value (#53) is also automatically set to the minimum position integral limiting value that can generate the maximum torque and maximum thrust in motor lock status. It is not necessary to set parameters related to feed forward and filter again.

### [Related parameters]

#38	Servo stiffness settings
#50	Position control bandwidth
#51	Velocity control bandwidth
#53	Position integral limiting value

# 5 Functions

## 5.9 Other Functions

### 5.9.1 Settling Wait, Position Settling Status, and Positioning Status

*Position settling status* refers to the status where the position deviation (in pulse coordinates) is within the prescribed range in the pulse coordinate system. The prescribed range is set by #58 *Position settling width* in command units. The #362 *Pulse position deviation after filtering* monitor value or the #322 *Pulse position deviation* monitor value are used for the evaluated position deviation depending on whether the #60 *Enable/Disable filter at position settling signal generation* parameter is set to enable or disable, respectively. Position settling status is displayed in the #328 *Position settling status* monitor. The “COIN”: position settling status LED on the front panel also turns on and indicates the position settling status. In addition, it is output to “COIN” of the CN3 analog monitor interface as a digital signal.

*Positioning status* is the status where an acceleration/deceleration command for a move is completed and in position settling status. The positioning settling status is displayed in the #329 *Positioning status* monitor.

*Settling wait* is a function invoked to keep on waiting until the positioning status is reached at the end of a move. Settling wait can be made in three ways depending on the operation: never perform settling wait, always perform settling wait, or follow the setting of the #106 *Settling wait enable* parameter.

	Operation
Never perform	Jog move, test operation, auto-tuning operation
Always perform	Homing move
Follow #106 setting	Program operation, signal search move, MDI operation, index Type A operation, index Type B operation, table reference operation

[Related parameters]

#58	Positioning settling width
#60	Enable/disable filter at position settling signal generation
#106	Settling wait enable

## 5.9.2 Velocity Monitor and Analog Monitor

The current velocity value of the motor is output to “VEL” of the CN3 analog monitor interface as the *velocity monitor* signal.

The signal sensitivity of the velocity monitor ([V/rps] in case of a rotating DYNASERV motor and [V/mps] in case of a linear LINEARSERV motor) can be obtained by multiplying the #69 *Velocity monitor gain* parameter setting by the #356 *Digital velocity sensitivity* monitor value. For example, if the setting of #69 is 6.55V/8192 digits and the value of #356 is 4800 [digit/rps] in a rotating motor, the signal sensitivity of the velocity monitor is 3.84 [V/rps]. The velocity monitor signal is output in the range of  $\pm 6.55V$ .

Moreover, it is possible to output only the AC element of the current velocity value of the motor via the setting of the #75 *Velocity monitor selection* parameter.

One of the data items below is output to “AMON” of the CN3 analog monitor interface as an *analog monitor* signal.

The content of the analog monitor can be selected by the #70 *Analog monitor selection* parameter. Depending on the selected content, the signal sensitivity is adjusted using the corresponding monitor gains #71 to 74. The analog monitor signals are output in the range of  $\pm 6.55V$ .

Analog monitor selection	Unit	Monitor gain
Position deviation	Pulse	#71 Positioning error monitoring gain (Analog monitor)
Test operation response	Pulse	#72 Test operation monitoring gain (Analog monitor)
Position command value	Pulse	#73 Position monitoring gain (Analog monitor)
Position current value	Pulse	#74 Position differential value monitor gain (Analog monitor)
Position command differential value	pps	
Position current differential value	pps	

### [Related parameters]

#69	Velocity monitoring gain
#70	Analog monitor selection
#71	Positioning error monitoring gain (Analog monitor)
#72	Test operation monitoring gain (Analog monitor)
#73	Position monitoring gain (Analog monitor)
#74	Position difference value monitor gain (Analog monitor) #74
#75	Velocity monitor selection

## 5.9.3 Brake Signal

BRK+ and BRK- are output to the TB2 external sensor interface as brake signal outputs that operate linked to the Servo ON status. The brake signal is a relay contact output. The contact opens when the brake should be applied such as when the power is disconnected or the driver is in Servo OFF status, and the contact short circuits when the brake should be released.

The Servo ON status and the brake signal operate according to the timing diagram shown below via the #89 *Brake turn OFF delay time upon Servo ON* and #90 *Advanced brake turn ON before Servo OFF* parameters.

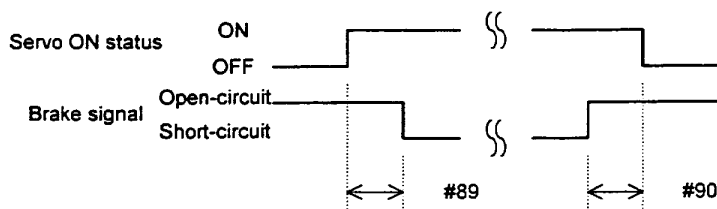

### [Related parameters]

#89	Brake turn OFF delay time upon Servo ON
#90	Advanced Brake turn ON before Servo OFF

## 5.9.4 Area Signals

The area signals display whether or not the motor is within the pre-set range. Two channels are available. The range is set by setting the coordinate value at which to turn on the signal in the #161 *Area signal 0 On* and #163 *Area signal 1 On* parameters in command units. In addition the coordinate value at which to turn off the signal in the #162 *Area signal 0 Off* and #164 *Area signal 1 Off* parameters in command units. How the signal is output with respect to the motor position depends on whether the coordinate value to turn on is greater or smaller than the coordinate value to turn off. The figure below shows each case in linear coordinate and rotational coordinate systems.

The status of the area signal is displayed in #331 *Area signal 0 status* and #332 *Area signal 1 status* monitors. It is also output to the PLC interface. Refer to Section 6.2, "PLC Interface."

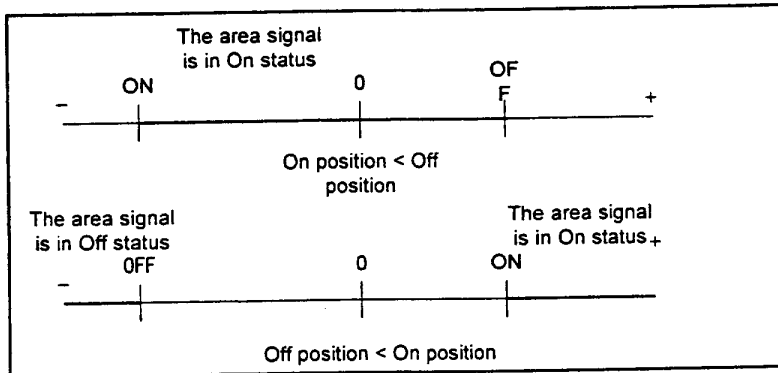

[Linear coordinate system]

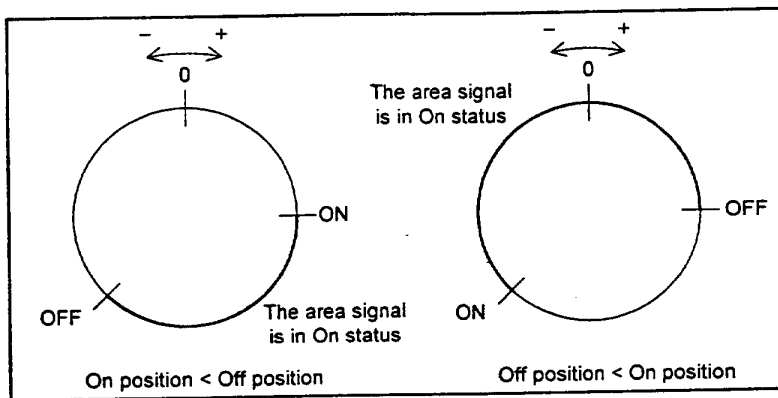

[Rotational coordinate system]

## [Related parameters]

#161	Area signal 0 On
#162	Area signal 0 Off
#163	Area signal 1 On
#164	Area signal 1 Off

## 5.10 Special Parameter Processing

The setting values of the parameters listed below are automatically changed inside the driver by the operation of the driver.

### 5.10.1 Internal Generation of Parameter Initial Values

The initial values of all of the following parameters when they are reset will be generated internally by the motor:

[Related parameters]

#9	Feeding velocity	Value obtained by converting the motor rating velocity into command units.
#10	Jog velocity	Value obtained by converting the motor rating velocity into command units.
#11	Over-travel search velocity during a homing move	Value obtained by converting the motor rating velocity*0.1 into command units.
#12	Homing operation: Home sensor proximity signal search velocity	Value obtained by converting the motor rating velocity*0.1 into command units.
#15	Homing operation: Origin position offset move feed velocity	Value obtained by converting the motor rating velocity*0.1 into command units.
#31	Operation width under testing mode	Value obtained by converting the motor rating velocity*0.002 into command units.
#32	Operation width under Auto-tuning	Value obtained by converting the motor rating velocity*0.02 into command units.
#209	Scaling data (command unit side)	Motor resolution
#210	Scaling data (pulse side)	Motor resolution
#212	Straight line coordinate selection	Select rotation coordinates for rotation type, and straight line coordinates for linear type.
#213	Maximum velocity	Value obtained by converting the motor rating velocity into command units.

### 5.10.2 Limiting and Checking the Maximum Velocity When Changing Scaling Data and Maximum Velocity Parameter

The following maximum velocity limiting and checking are performed during processing when the power is turned ON after data related to scaling is changed:

- Limit item 1) A limit is set when the maximum velocity in command units [unit/s] exceeds 9999999.
- 2) A data checksum error is generated when the maximum velocity in pulse units [pls/s] exceeds 8000000.

### 5.10.3 Auto Conversion and Clear Functions When Changing Scaling Data

When scaling data is changed, the following parameters are automatically converted:

[Related parameters]

#9	Feeding velocity
#10	Jog velocity
#11	Over-travel search velocity during a homing move
#12	Homing operation: Home sensor proximity signal search velocity
#15	Homing operation: Origin position offset move feed velocity
#29	Offset distance from the Home position
#31	Operation width under testing mode
#32	Operation width under Auto-tuning
#58	Positioning settling width
#87	(+) direction soft limit settings
#88	(-) direction soft limit settings
#161	Area signal 0 ON
#162	Area signal 0 OFF
#163	Area signal 1 ON
#164	Area signal 1 OFF
#213	Maximum velocity

When coordinates (rotation/straight line) scaling data is changed, the following parameters will be cleared:

[Related parameters]

#161	Area signal 0 ON
#162	Area signal 0 OFF
#163	Area signal 1 ON
#164	Area signal 1 OFF

### 5.10.4 Limiting the Maximum Parameter Values

Limit processing is performed for the following parameters related to velocity at the time of parameter entry and when the power is turned ON.

[Related parameters]

#9	Feeding velocity
#10	Jog velocity
#11	Over-travel search velocity during a homing move
#12	Homing operation: Home sensor proximity signal search velocity
#15	Homing operation: Origin position offset move feed velocity

[At the time of parameter entry]

If a parameter value exceeds #357 *Maximum velocity monitor value* when it is set by the user, it will be processed as out of range data. However, limit processing is not performed in the hold-on state (while downloading parameters), when changing data related to scaling, or when changing the maximum velocity data.

[When the power is turned ON]

A limit is applied using the value equivalent to #357 *Maximum velocity monitor value* during processing when the power is turned ON after data related to scaling or maximum velocity data is changed.

# Chapter 6

## Control Interfaces

---

### 6.1 RS232C Interface

- 6.1.1 Overview
- 6.1.2 Connection and Setting
- 6.1.3 Communication Specifications
- 6.1.4 @ Commands
- 6.1.5 Parameter Commands

### 6.2 PLC Interface

- 6.2.1 Overview
- 6.2.2 Connection, Setting, and I/O Mapping
- 6.2.3 Operation 1
- 6.2.4 Operation 2



## 6.1 RS232C Interface

### 6.1.1 Overview

The CN1 RS232C communication connector is provided in order to make connection with host devices such as PCs and PLCs via the RS232C. The *operation display pendant* (abbreviated as TBX, optional device) can also be connected to this connector. Refer to Chapter 8, "Operation Display Pendant" for a description of how to use the operation display pendant. This chapter explains how to connect the CN1 RS232C communication connector to devices other than the operation display pendant.

In the RS232C interface, two communication modes are available. The first is a *single channel communication* where the connection is made 1:1 with the host device, and the other is a *multi-channel communication* where 1:N communication can be performed by connecting one host device with several of these drivers (a maximum of nine). Please note that the connection and operation methods are different for each communication mode.

In addition, the *PC utility* (optional) running under Windows can also be connected to the drivers via the RS232C interface in order to support setting, operation, and maintenance work on the drivers. Refer to Chapter 7, "DrvMII PC Utility" for a description of how to use the PC utility.

### 6.1.2 Connection and Setting

#### (1) [Connectors and terminal assignment]

Made by Japan Aviation Electronics  
DELG-J9SAF13L6 (9 pins)

01	FG	06	XTBXON
02	RxD	07	XTBXENG
03	TxD	08	+5V
04	(NC)	09	SG
05	SG		

Do not use these connections, since they are used for the operation display pendant.

#### (2) [Single channel]

The connection cables (optional) are available according to the PC to be connected (DOS/V, NEC PC98).

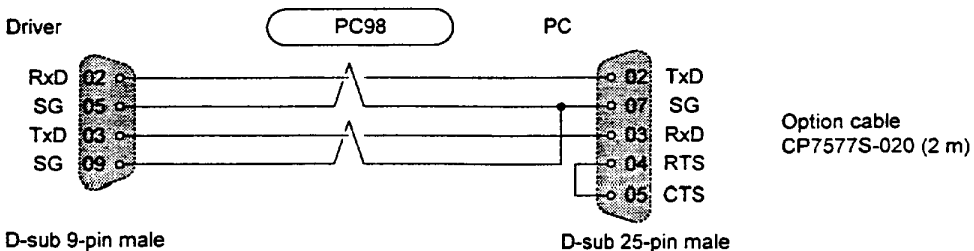
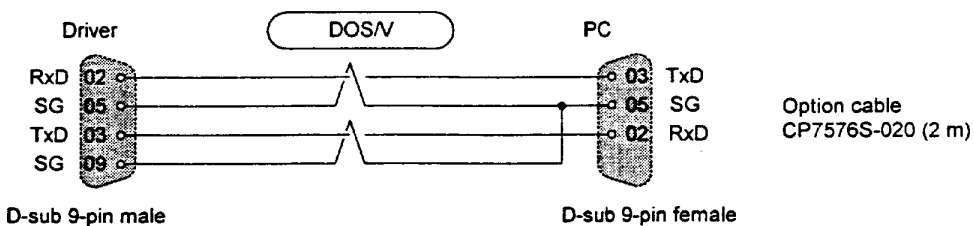

In order to set the communication mode to the single channel mode, the rotary switch RS-ID on the front panel should be turned to "0." This setting should be made before turning the power on.

(3) [Multi-channel]

When preparing for multi-channel communication, connect the host device and a maximum of nine drives in a loop shape as shown in the figure below.

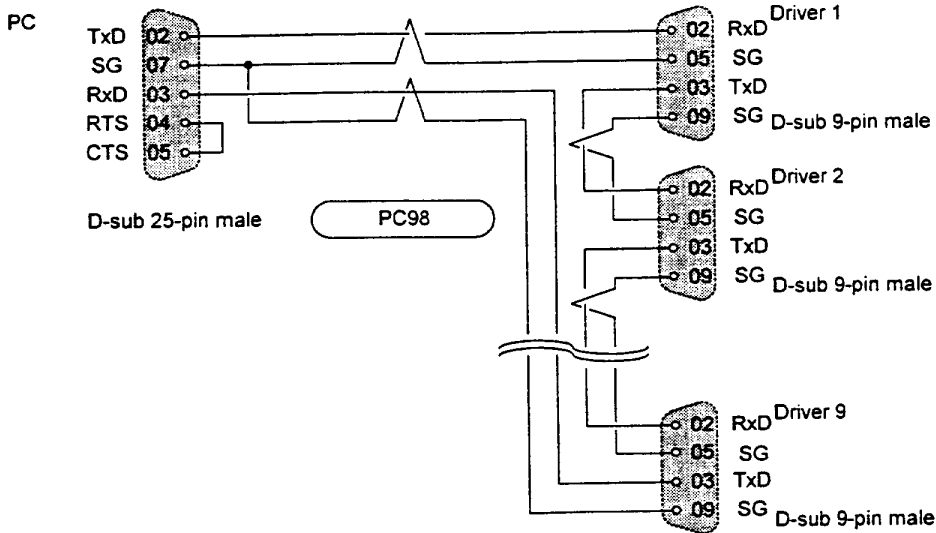
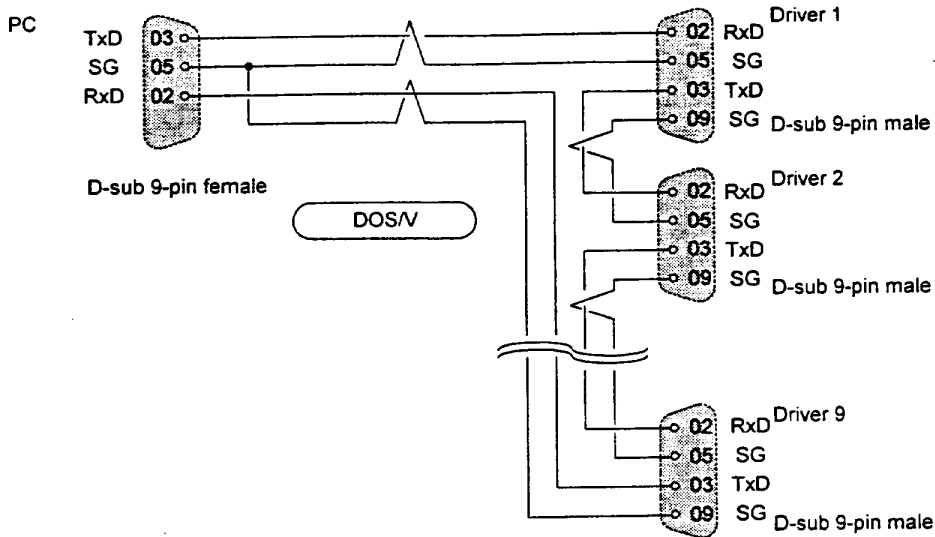

In multi-channel communication, the host device is assigned to *host ID* "0." The drivers should be set as *slave stations* and the *IDs* should be set for each driver from "1" to "9" in such a way that the station numbers do not overlap, using the rotary switch RS-ID on each driver's front panel. The order of the IDs does not need to be the same as the order of connection. This setting should also be made before turning the power on.

## 6.1.3 Communication Specifications

## (1) [Communication parameters]

Communication method	Start-stop system, text communication
Communication speed	9600 bps
Stop bit	1 bit
Data length	8 bits
Parity	None
Terminate	CR (both transmission and reception)
Flow control	None

## (2) [Single channel and multi-channel]

	Single channel	Multi-channel
Topology	Cross	Ring
ID	Unnecessary	Host device 0 Drivers 1 to 9
Destination specification	Unnecessary	Add the destination ID at the beginning of the packets From the host device to drivers: n****CR (n: slave station ID) From drivers to the host device: 0n****CR (n: slave station ID)

## (3) [Transmission from the host device to drivers]

The number of characters to be transmitted should be 128 letters or less, including the slave station ID, recognition key, transmission character string, and CR.

Single channel

Recognition key	Transmission character string	CR
-----------------	-------------------------------	----

Multi-channel

Slave station ID	Recognition key	Transmission character string	CR
------------------	-----------------	-------------------------------	----

## (4) [Response from drivers to the host device]

The number of response characters should be 128 letters or less, including 0, slave station ID, recognition key, transmission character string, and CR.

Single channel

Recognition key	Response character string	CR
-----------------	---------------------------	----

Multi-channel

0	Slave station ID	Recognition key	Response character string	CR
---	------------------	-----------------	---------------------------	----

## (5) [Recognition key]

The recognition key is a function provided so that the host device can recognize that a response is a reply to a specific transmission by the host device. A maximum of 15 “!” characters can be included in the recognition key part. If more than 15 are added, the remainder of the number divided by 16 is processed as the actual recognition key number.

When the host device transmits a message to a driver and attaches N recognition keys to the transmission character string, the driver will send a response message back in which it attaches N recognition keys to that transmission character string. If, for instance, the host device issues a transmission character string to a driver that does not generate an immediate response, the host device may issue the next transmission character string before the response is returned. In such cases, it becomes difficult for the host device to recognize to which transmission character string the response character string returned afterward is issued. In this case, by issuing transmission character strings with different recognition key numbers, it becomes possible to judge to which transmission character string a particular response corresponds, simply by obtaining the recognition key number as the response is received.

(6) [Transmission character string]

Transmission character strings are classified as follows. The details about the @ commands and parameter commands will be explained separately in Section 6.1.4, “@ Commands” and Section 6.1.5, “Parameter Commands.”

	Explanation	Receivable status
@ commands	Commands for operating the driver	Receivable status changes depending on the command.
Parameter commands	Commands for setting parameters and reading parameter/monitor values.	Receivable status changes depending on the parameter.
Parameter statements	Statements for setting parameters in program operation and MDI operation.	Receivable at program registration and during MDI operation.
NC executable statements	Statements for operating the motor in program operation and MDI operation.	
Control parameters	Statements for controlling the flow of a program during program operation.	Receivable only at program registration.
Comment statements	Statements for making the content of a program easy to understand, not related to operation.	

Refer to Section 5.6, “Programming Language.”

(7) [Response character string]

A response character string is structured as follows.

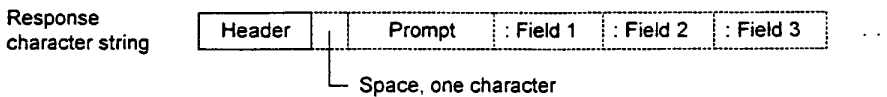

Response character strings are classified as follows.

	Header structure	□ part	■ part	Explanation
General	R□■	Number of fields	For the field expression method; see the note.	Normal response character strings to a transmission character string. The number of fields changes depending on the content of the response.
Error	ERR□□.■	Error/alarm code (main)	Error/alarm code (sub)	Response character string to a transmission character string at error and alarm. Fields never exists.
Alarm	ALM□□.■			

Note: In case of a general response the ■ part of the field is expressed in one of the following ways:

- 0: In case there is no field
- D: Character string expressed in decimal
- B: Binary expression (8, 16, 32 digits)
- H: Hexadecimal expression (2, 4, 8 digits)
- S: Character string
- Z: Other than above (character string, etc.)

The following shows some examples of response character strings.

```
R00
R1D Position control bandwidth: 12
R1B Sensor group signal status: 00010000
ERR30.0 Servo not ready
ALM60.0 Cannot interpret command
```

## 6.1.4 @ Commands

Some of the @ commands may not be controlled because of the *operation mode* setting. Refer to Section 5.1, "Operation Mode" for an explanation of the operation mode.

Command format      @    Command number    : Field 0    : Field 1    : Field 2    ...

Command name	Command No.	No. of fields	Response at normal operation
Abort	1	0	R00
Stop	2	0	
Start	3	Maximum of 4	
Error reset	4	0	
Servo ON/OFF	8	1	
M answer	9	0	
Homing offset position setting	10	1	
Jog move command	11	1	
Integral position control operation switching	12	1	
Coordinate system settings	13	1	

## (1) Servo ON/OFF @8: Field 0

The Servo ON/OFF command can be issued via the RS232C interface when the setting of the operation mode has given the main operation authority to the RS232C interface rather than the PLC interface.

The servo goes into the ON status when field 0 contains "1," and OFF when it contains "0." In addition to this command, the actual Servo ON/OFF status is affected by the Servo ON enable/disable command of the PLC interface and the Servo ON disable setting of the SRV DS switch on the front panel. Refer to the table below. Moreover, the initial Servo ON status is determined by the setting of the #216 *Servo ON status upon power up during RS232C operations* parameter.

A response is issued immediately regardless of whether or not the motor actually went into the servo ready status. If the next command requires that the motor is in the servo ready status, make sure to check the #305 *Servo ready monitor* before sending that command.

Servo ON/OFF @8: □	PLC interface Servo ON enable/disable	Front panel SRV DS Servo ON disable	Actual servo status	
OFF @8:0	Disabled	Disabled	Servo OFF	
		Enabled		
	Enabled	Disabled		
		Enabled		
ON @8:1	Disabled	Disabled		
		Enabled		
	Enabled	Disabled		Servo ON
		Enabled		

## [Related parameters]

#216 Servo ON status upon power up during RS232C operations

(2) Start @3: Field 0: Field 1: Field 2: Field 3

Start commands begin operating actions other than jog moves. They can be issued via the RS232C interface when the setting of the operation mode has given the main operation authority to the RS232C interface. They are only executable while in the *idle status*.

The number and content of fields vary depending on the operations to run. They are summarized in the table below. The program operations, index Type A operations, index Type B operations, and table reference operations are explained in detail because it is different how the fields are assigned in these cases.

A response is issued when the corresponding operation is completed. In case of test operations, MDI operations, etc. that do not end by themselves, the next operation can be performed without waiting for the response.

Operating action name	Command	No. of fields
Test operation	@3:0	1
Auto-tuning operation	@3:1	1
Homing move	@3:3	1
Program operation	@3:4:start-up option 1:start-up option 2	1 to 3
Signal search move	@3:6	1
MDI operation	@3:7	1
Index Type A operation	@3:8:start-up option 1:start-up option 2: start-up option 3	2 to 4
Index Type B operation	@3:9:start-up option 1:start-up option 2: start-up option 3	2 to 4
Table reference operation	@3:10:start-up option 1:start-up option 2: start-up option 3	2 to 4
Mechanical setting mode	@3:15	1

[Program operation]

Start-up options 1 and 2 provide the program number and block number, respectively. There are three ways to provide a command: *provide neither start-up option 1 nor 2*, *provide only start-up option 1*, and *provide both start-up options 1 and 2*.

The commands that provide only start-up option 1 are the most commonly used commands. The execution begins from the top of the program with the number specified by start-up option 1 and runs from there [ @3:4:program number].

In case of a command that does not provide neither start-up option 1 nor 2, the program with the execution program number stored is run from the block with the stored block number [ @3:4].

In case of a command that provides both start-up options 1 and 2, the program with the number specified by start-up option 1 is run from the block with the block number specified by start-up option 2 [ @3:4:program number: block number].

[Index Type A Operation, Index Type B Operation]

Start-up option 1 provides the index number, start-up option 2 provides the selection of absolute or incremental move, and start-up option 3 provides the moving direction option. There are three ways to provide a command: *provide only start-up option 1*, *provide start-up options 1 and 2*, and *provide start-up options 1, 2 and 3*. Start-up option 1 must always be provided.

Start-up option 1 (index number) becomes the relative value to the current operation command value in case of an incremental move, and the target operation command value in case of an absolute move.

Start-up option 2 (selection of absolute move/incremental move) selects an incremental move when the field contains 0 and an absolute move when the field contains 1. If the *#104 ABS/INC setting during table index operation* parameter is set to anything other than *start-up option dependence*, the specification of start-up option 2 is invalid. When #104 is set to start-up option dependence, start-up option 2 must be set. If start-up option 2 is not set at this point, it is assumed that 0 is set and an incremental move is performed.

Start-up option 3 (moving direction option) selects Type 0 if the field contains 0, Type 1 if the field contains 1, and Type 2 if the field contains 2. If the *#105 Moving direction option for rotational coordinates* parameter is set to anything other than *start-up option dependence*, the specification of start-up option 3 is invalid. When #105 is set to start-up option dependence, start-up option 3 must be set. If start-up option 3 is not set at this point, it is assumed that 0 is set and Type 0 is selected.

Note: Regarding the moving direction in rotational coordinates

Type0 Proximity rotational move (multiple rotations are not allowed).

Type1 Does not cross the rotational coordinate's home position (multiple rotations are not allowed).

Type2 Calculates the target position relative to the current rotational coordinate's home position and determines the direction (multiple rotations are allowed).

[Related parameters]

#104	ABS/INC setting during table index operation
#105	Moving direction option for rotational coordinates

[Table reference operation]

Start-up option 1 provides the table number, start-up option 2 provides the selection of absolute or incremental move, and start-up option 3 provides the moving direction option. There are three ways to provide a command: *provide only start-up option 1*, *provide start-up options 1 and 2*, and *provide start-up options 1, 2 and 3*. Start-up option 1 must always be provided.

The table data value and option are obtained based on the number specified in start-up option 1 (table number). The table data value obtained is set as a value relative to the current operation command value in case of an incremental move, and as the target operation command value in case of an absolute move.

Start-up option 2 (selection of absolute move/incremental move) selects an incremental move when the field contains 0 and an absolute move when the field contains 1. If the *#104 ABS/INC setting during table index operation* parameter is set to anything other than *start-up option dependence*, the specification of start-up option 2 is invalid. When #104 is set to start-up option dependence, start-up option 2 must be set. If start-up option 2 is not set at this point, it is assumed that 0 is set and an incremental move is performed.

Start-up option 3 (moving direction option) selects Type 0 if the field contains 0, Type 1 if the field contains 1, and Type 2 if the field contains 2. If the *#105 Moving direction option for rotational coordinates* parameter is set to anything other than *start-up option dependence*, the specification of start-up option 3 is invalid. When #105 is set to start-up option dependence, start-up option 3 must be set. If start-up option 3 is not set at this point, it is assumed that 0 is set and Type 0 is selected.

Note: Regarding the moving direction in rotational coordinates

Type0 Proximity rotational move (multiple rotations are not allowed).

Type1 Does not cross the rotational coordinate's home position (multiple rotations are not allowed).

Type2 Calculates the target position relative to the current rotational coordinate's home position and determines the direction (multiple rotations are allowed).

[Related parameters]

#104	ABS/INC setting during table index operation
#105	Moving direction option for rotational coordinates

### (3) Stop @2

Stop commands are used to end operating actions other than jog moves. They can be issued via the RS232C interface when the setting of the operation mode has given the main operation authority to the RS232C interface. The driver's response to stop commands varies depending on the current operating action. Refer to the table below.

The response is issued immediately.

Operating action name	Driver response
Test operation	Ends the operation when the motor returns to the start position.
Auto-tuning operation	Ends the operation when the oscillation command to the motor is completed.
Homing move	Immediately decelerate and stop the move, and ends the operation.
Program operation	Ends the operation when a block is executed and completed.
Signal search move	Immediately decelerate and stop the move, and end the operation.
MDI operation	Ends the operation when execution of the current NC executable statement or parameter statement input via RS232C is completed.
Index Type A operation	Invalid (ignored)
Index Type B operation	Invalid (ignored)
Table reference operation	Invalid (ignored)
Mechanical setting mode	Invalid because this operation cannot be completed (ignored).

### (4) Abort @1

The abort command stops operating actions other than jog moves. It functions irrespectively of the operation mode.

Unlike with the stop commands, the motor immediately decelerates and stops, and the operating action is ended even during an operation that involves movement. When the M function is being executed, the abort command stops the execution and ends the operating action.

The response is issued immediately.

### (5) Error reset @4

The error reset command cancels error statuses of the driver. It functions irrespectively of the operation mode. It can only be run while in the *idle status*.

Depending on the error content, there are errors that cannot be canceled or errors that cause the same errors again immediately after being canceled.

The response is issued immediately.

### (6) Integral position control operation switching @12:field 0

The integral position control operation switching command switches the operation status of integral operation in the position control part. It can be issued via the RS232C interface when the setting of the operation mode has given the main operation authority to the RS232C interface.

When field 0 is "1," integral operation is executed, and when it is "0," integral operation is not executed. When the power is turned on, the integral operation is in the executable status by default.

The response is issued immediately.



## (7) Homing offset position setting @10: Field 0

The homing offset position setting command instructs the #29 *Offset distance from the home position* parameter to auto-set so that the current motor position will become the position after homing is completed from the next time. It functions irrespectively of the operation mode. It can only be run while in the idle status. Field 0 provides the method by which to determine the #29 parameter in a rotational coordinate system. In linear coordinates, the method to determine the parameter is unique, so the setting of field 0 is ignored. When the command is issued, the current command unit command value and the value of the #29 parameter at that point are added. This value is temporality stored in the #29 parameter. In a linear coordinate system, this temporary value is used as the setting value as it is. In a rotational coordinate system, the temporary set value is processed by the setting of field 0, then stored in the #29 parameter. In rotational coordinates, the temporary set value is standardized so that it becomes 0 or more and less than the #324 *Scaling data (command unit side)* monitor value. The set value of the #29 parameter is generated from the standardized value and the setting of field 0.

- If field 0 is "0"
  - If the standardized value is 0 or more and less than half of the value of #324:
    - #29 is set to the standardized value.
  - If the standardized value is more than half of the value of #324:
    - #29 is set to the value of #324 minus the standardized value.
- If field 0 is "1":
  - #29 is set to the standardized value.
- If field 0 is "-1":
  - #29 is set to the value of #324 minus the standardized value.

The response is issued immediately.

## (8) M answer @9

The M answer command is a response command to an M code notification from the driver. This command can be issued when the #102 *Enabling the selection of RS232C for the M function interface* parameter is set in such a way that the M function communicates with the host device via the RS232C interface and a response character string of the form "M\*\*" is notified as M code to the host device from the driver. Issuing this command to the driver completes the M function.

There is no response to this command.

## (9) Jog move command @11: Field 0

The jog move command is for performing jog operations. This command can be executed in the idle status when the #217 *Jog move operation: RS232C selection* parameter is set so that operations are performed via the RS232C interface.

When field 0 contains "1" a move in the + direction is commanded, when it contains "-1" a move in the - direction is commanded, and when it contains "0," a stop command is issued.

In the idle status, a jog move is performed as commanded by this command. If a start command is issued during a jog move, the move is immediately decelerated and stopped, after which the operation is started. If the operation is ended after that, the motor remains stopped regardless of the jog move status before starting the operation.

The response is issued immediately.

## (10) Coordinate system setting @13: Field 0

The coordinate system setting command is for setting the current operation command value to the value specified by field 0. It functions irrespectively of the operation mode. It can only be run in the idle status. The response is issued immediately.

(11) Other convenient commands

Command name	Command No.	Number of fields	Response at normal operation
Status request	0	1	R3H
Software driver reset	96	0	None

[Status request] @0:0

This command notifies the status of the driver. It functions irrespectively of the operation mode. The response is issued immediately.

Response character string: R3H:driver status:execution program number:execution block number

Driver status

Bit No.	Content	Value	
		0	1
0	Operation mode	PLC	RS232C
1	Servo ready	Not ready	Ready
2	Operation is being executed	Not being executed	Being executed
3	Axis operation is being executed	Not being executed	Being executed
8	Program is being executed	Not being executed	Being executed
9	Mechanical setting mode is being executed	Not being executed	Being executed
16	Error status	Not in error status	Error status
17	Alarm status	Not in alarm status	Alarm status
Others	(Reserved)		

[Software driver reset] @96

This command is software equivalent to turning the power to the driver off and on. There is no response.

## 6.1.5 Parameter Commands

Through the use of parameter commands, it is possible to refer to values of parameters and monitor (*reference commands*), assign numerical values and variables to parameters (*simple setting commands*), and assigning results of arithmetic operations on numerical values and variables to parameters (*calculation result setting commands*). The response is issued immediately.

A reference command issues a transmission character string simply containing a variable given directly by #\*\*\*. At normal operation, if a response is generated, a response character string that begins from "R1□" and one data is returned.

In simple setting commands and calculation result setting commands, the left-hand side must be variables expressed by #\*\*\*. The right-hand side can be direct numerical values, or it can contain variables such as a parameter/monitor referred to by #\*\*\*. The response at normal operation is "R00."

## [Reference commands]

#50	Reads the value of parameter #50	Response character string: R1D position control bandwidth:12
#337	Reads the value of monitor #337	Response character string: R1B sensor group signal status:00010000

## [Simple setting commands]

#400=100	Sets 100 to variable #400.
#400=#401	Sets the value stored in #401 to variable #400.

## [Calculation result setting commands]

The following operands can be used:

+	Addition
-	Subtraction
*	Multiplication
/	Division
%	Remainder at integer division

#400=100 + 20	Sets the result of adding 100 and 20 to variable #400.
#400=#401 - 20	Sets the value obtained by subtracting 20 from the value stored in #401 to variable #400.
#400=100 * #401	Sets the result of multiplication of 100 and the value stored in #401 to variable #400.
#400=#400 / #401	Sets the value obtained by dividing the value stored in #400 by the value stored in #401 to variable #400.
#400=100%30	Sets the remainder of 100 divided by 30 to variable #400.

## 6.2 PLC Interface

### 6.2.1 Overview

The PLC interface for this driver can be chosen from a list of selectable options. It is possible to select a *contact I/O interface*, a *CC-Link interface* (under development), a *PROFIBUS interface*, and a *DeviceNet interface* (under development).

The contact I/O interface is an I/O interface with 32 input points (sink type output support photo coupler inputs) and 20 output points (sink type open collector output).

In this technical manual, only the contact I/O interface is explained.

### 6.2.2 Connection, Setting, and I/O Mapping

[Connectors and terminal assignment]

#### CN4

Made by Honda Tsushin Kogyo  
Connector PCR-S50FS  
Cover PCR-LS50LA

26	DI_24	01	COMP1
27	DI_25	02	DI_0
28	DI_26	03	DI_1
29	DI_27	04	DI_2
30	DI_28	05	DI_3
31	DI_29	06	DI_4
32	DI_30	07	DI_5
33	DI_31	08	DI_6
34	DO_0	09	DI_7
35	DO_1	10	DI_8
36	DO_2	11	DI_9
37	DO_3	12	DI_10
38	DO_4	13	DI_11
39	DO_5	14	DI_12
40	DO_6	15	DI_13
41	DO_7	16	DI_14
42	DO_8	17	DI_15
43	DO_9	18	DI_16
44	DO_10	19	DI_17
45	DO_11	20	DI_18
46	DO_12	21	DI_19
47	DO_13	22	DI_20
48	DO_14	23	DI_21
49	DO_15	24	DI_22
50	COMN1	25	DI_23

#### CN5

Made by Phoenix Contact  
Plug MC1,5/6-ST-3,81

01	COMP2
02	DO_16
03	DO_17
04	DO_18
05	DO_19
06	COMN2

# 6

## Control Interfaces

[Electrical specifications]

Input specifications	
Rated voltage	12 to 24 VDC ( $\pm 10\%$ )
Rated input current	4.1 mA/point (at 12 VDC) 8.5 mA/point (at 24 VDC)
Input impedance	3.0 k $\Omega$
Operation voltage (relative to COMP*)	At OFF 3.0VDC or less At ON 9.0VDC or more
Allowable leak current	OFF is guaranteed at 1.0 mA or less

Output specifications	
Rated voltage	12 to 24 VDC ( $\pm 10\%$ )
Maximum load current	0.1A/point, 0.5 A/common
ON voltage	0.5VDC or less
Leak current at OFF	0.1mA or less

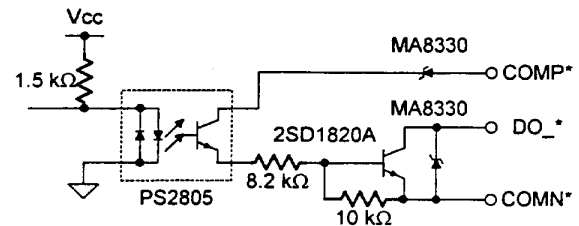
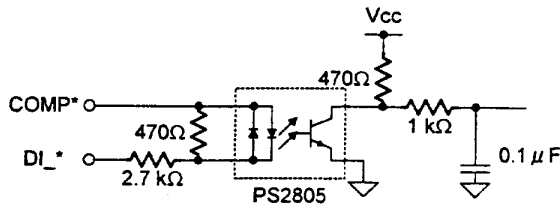

Note: COMP1 and COMP2 are independent, as are COMN1 and COMN2; they are not short circuited within the driver.

[I/O map]

	7	6	5	4	3	2	1	0	
DI									
Block0	IN_MODE .3	IN_MODE .2	IN_MODE .1	IN_MODE .0	IN_MODE _STOP	IN_MODE _START	IN_SERV O	IN_EMG	DI_7 to DI_0
Block1	IN_I_CODE .7	IN_I_CODE .6	IN_I_CODE .5	IN_I_CODE .4	IN_I_CODE .3	IN_I_CODE .2	IN_I_CODE .1	IN_I_CODE .0	DI_15 to DI_8
Block2	IN_POS _INH	reserve	IN_ERRCODE _REQ	IN_M_A N S	IN_ERR _RESET	IN_ABOR T	IN_INTER LOCK	IN_PRG _REWIND	DI_23 to DI_16
Block3	reserve	IN_ABS _STR_OP T	IN_ROT DIR_STR_ OPT.1	IN_ROT DIR_STR_ OPT.0	IN_SIGN _INDEX	IN_OVER RIDE_SE L	IN_JOG _DN	IN_JOG _UP	DI_31 to DI_24

	7	6	5	4	3	2	1	0	
DO									
Block0	reserve	OUT_ERRCODE _OUT	OUT_M_EN	OUT_ALARM	OUT_ER R	OUT_MODE _EXE	OUT_SRDY	OUT_CPURDY	DO_7 to DO_0
Block1	OUT_0_CODE.7	OUT_0_CODE.6	OUT_0_CODE.5	OUT_0_CODE.4	OUT_0_CODE.3	OUT_0_CODE.2	OUT_0_CODE.1	OUT_0_CODE.0	DO_15 to DO_8
Block2	-	-	-	-	OUT_AREA1	OUT_AREA0	reserve	OUT_COI N	DO_23 to DO_16

### 6.2.3 Operation 1

Some of the operations commanded by input signals via the PLC interface may not function depending on the *operation mode* setting. Refer to Section 5.1, “Operation Mode” for an explanation of the operation mode, In this section, the operations that are common regardless of the type of the PLC interface will be explained.

#### (1) Explanation of signals

##### [Input signals]

Abbreviated name	Signal name	Contact I/O
IN_EMG	Emergency stop input	DI_0
IN_SERVO	Servo command input	DI_1
IN_MODE_START	Operating action start command input (start)	DI_2
IN_MODE_STOP	Operating action end command input (stop)	DI_3
IN_MODE [3..0]	Operation mode number input (binary)	DI_7 to 4
IN_I_CODE [7..0]	Code input (BCD)	DI_15 to 8
IN_PRG_REWIND	Program auto-rewind input	DI_16
IN_INTERROCK	Interlock command input	DI_17
IN_ABORT	Operating action abort command input (abort)	DI_18
IN_ERR_RESET	Error reset command input	DI_19
IN_M_ANS	M answer input	DI_20
IN_ERRCODE_REQ	Error code request input	DI_21
IN_POS_INH	Integral position control operation disable input	DI_23
IN_JOG_UP	Jog + command input	DI_24
IN_JOG_DN	Jog – command input	DI_25
IN_OVERRIDE_SEL	Velocity override selection input	DI_26
IN_SIGN_INDEX	Index sign input during index operation	DI_27
IN_ROTDIR_STR_OPT [1..0]	Moving direction at rotational coordinate start-up option input (binary)	DI_29 to 28
IN_ABS_STR_OPT	ABS/INC start-up option input	DI_30

##### [Output signals]

Abbreviated name	Signal name	Contact I/O
OUT_CPURDY	CPU ready output	DO_0
OUT_SRDY	Servo ready output	DO_1
OUT_MODE_EXE	Operation under execution output	DO_2
OUT_ERR	Error status output	DO_3
OUT_ALARM	Alarm status output	DO_4
OUT_M_EN	M code enable output	DO_5
OUT_ERRCODE_OUT	Output during error/alarm code output	DO_6
OUT_O_CODE [7..]	Code output (BCD)	DO_15 to 8
OUT_COIN	Position settling status output	DO_16
OUT_AREA0	Area signal 0 output	DO_18
OUT_AREA1	Area signal 0 output	DO_19

# 6 Control Interfaces

## (2) I/O logic setting

It is possible to set the logical relationship between the contact status and the driver signal status for all input and output signals separately in contact units.

The input signals IN\*\*\* are processed via the I/O logical conversion and are then expressed as a logical input signal \*\*\*. If the signal status is reached, it is expressed as 1 and if the status is not reached, expressed as 0. A logical output signal \*\*\* is expressed as 1 if the status is reached and 0 if the status is not reached. After conversion via the I/O logical setting, it becomes an output signal OUT\_\*\*\*.

The I/O logical settings at the time of shipment from the factory are set to *positive logic* for all input and output signals. In other words, the internal input and output signals are set to 1 when the corresponding contact points are turned ON. By setting the I/O logical setting for IN\_SERVO to negative logic using the PC utility, it is possible to connect a PLC interface in the same state as it was shipped from the factory. As a result, an RS232C interface can be used to confirm basic operations.

Refer to Chapter 7 "DrvMII PC Utility" for a description of how to set the I/O logic.

## (3) Servo ON/OFF (SERVO)

The function of SERVO, the servo command input, changes depending on whether the main operation authority by the operation mode is given to the RS232C interface or the PLC interface.

If the operation mode is set to the RS232C interface, the servo command input functions as the Servo ON enable/disable function. Servo ON is enabled in the status 1. Servo ON is enabled at contact ON by positive logic setting for the input signal IN\_SERVO (the setting at shipment). By negative logic setting, Servo ON is enabled at contact OFF. Refer to Section 6.1.4, "@ Commands" for an explanation of how to use the Servo ON/OFF command in the RS232C interface operation mode.

If the operation mode is set to the PLC interface, the servo command input functions as the Servo ON/OFF command function. It becomes a Servo ON command when in the status 1. As for the input signal IN\_SERVO, the Servo ON command will be enabled at contact ON by positive logic setting (factory setting). By negative logic setting, the Servo ON command is enabled at contact OFF. Other than by this command, the actual Servo ON/OFF status is also affected by the setting of the Servo ON disable switch SRV DS on the front panel. See the table below.

Servo ON/OFF SERVO	SRV DS Servo ON disable on the front panel	Actual servo status
Status 0	Disabled	Servo OFF
	Enabled	
Status 1	Disabled	Servo ON
	Enabled	

(4) Start and stop (MODE\_START MODE\_STOP MODE [3..0])

The MODE\_START and MODE\_STOP commands start and stop operating actions other than job moves. They can be issued via the PLC interface when the setting of the operation mode has given the main operation authority to the PLC interface rather than the RS232C interface.

The operating action start and stop commands are issued in the status 1.

When a start command is issued by MODE\_START it depends on the operating action which signals (start-up options) that must be preset. When issuing a MODE [3..0] command, the number of the operating action you wish to perform must be always set. See the table below.

Moreover, if high-speed processing is not selected in the setting of the #215 PLC operation: Start signal processing speed selection parameter, the processing of start commands by MODE [3..0] and start-up options takes place at the next 10ms scan. In this case, the content of each signal is read and processed after 10ms has passed after the start command was issued. If the time delay between outputs by the PLC is in the order of several ms, the commands will function properly provided that they are set to the same time or before the start command is issued by MODE\_START. However, the time wasted with respect to issuing the start command should be added (10ms) instead. The total amount of wasted time until the motor start is thus 10ms (scan time) + 10ms (read delay) + internal delay time.

When high-speed processing is selected in the #215 parameter setting, the processing of the start command takes place at the next 2ms scan. In this case, the content of each signal when the start command is issued is read and processed. The time lag between outputs must be taken into consideration on the PLC side and set that much earlier. On the other hand, the time wasted with respect to the start command itself can be eliminated. The total amount of wasted time until the motor start is the 2ms (scan time) + internal delay time.

In MODE\_STOP, the driver response to a stop command varies depending on the operating action. See the table below. Note furthermore that operations of the *self-end type*, which end automatically when the operation is completed, do not require a stop command. Operations of the *non-self-end type*, which cannot complete the operation by itself, must be ended by a stop command by MODE\_STOP. In case of operations of the *non-end type*, which cannot be stopped once started, the stop command issued by MODE\_STOP is invalid. Refer to Section 5.3, "Operation Functions" for a listing of the end types of the different operations.

Outputs during MODE\_EXE operation execution maintain their under-execution status during MODE\_START command status (during status 1) after the operation is started, even after the operation is over.

No.	Name	Start-up option	End type	Response to stop command
1	Test operation	None	Non-self-end	End the operation upon returning to the start position.
2	Auto-tuning operation		Self-end	End the operation when the oscillation command to the motor is completed.
3	Homing move			Immediately decelerate and stop the move, and end the operation.
4	Program operations	I_CODE [7..0]	Self-end	End the operation when execution of the current block is completed.
5	Signal search move	None		Immediately decelerate and stop the move, and end the operation.
7	MDI operation		Non-self-end	End the operation when execution of the current NC executable statement or parameter statement input via RS232C is completed.
8	Index Type A operation	I_CODE [7..0], SIGN_INDEX, ROTDIR_STR_OPT [1..0] (when necessary), ABS_STR_OPT (when necessary)	Self-end	Invalid (ignored)
9	Index Type B operation			
10	Table reference operation			
15	Mechanical setting mode	None	Non-end	Invalid because the operation cannot be ended (ignored).

[Related parameters]

#215 PLC operation: Start signal processing speed selection



[Self-end type]

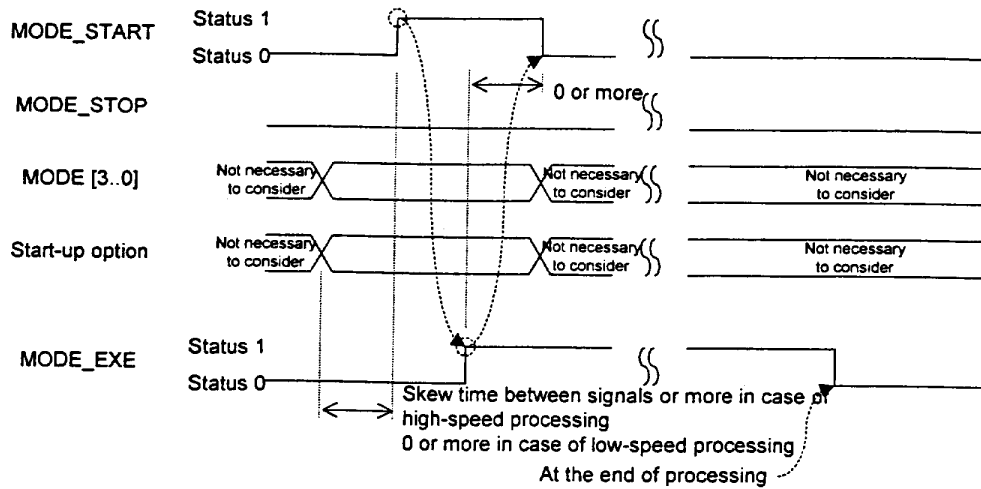

[Non-self-end type]

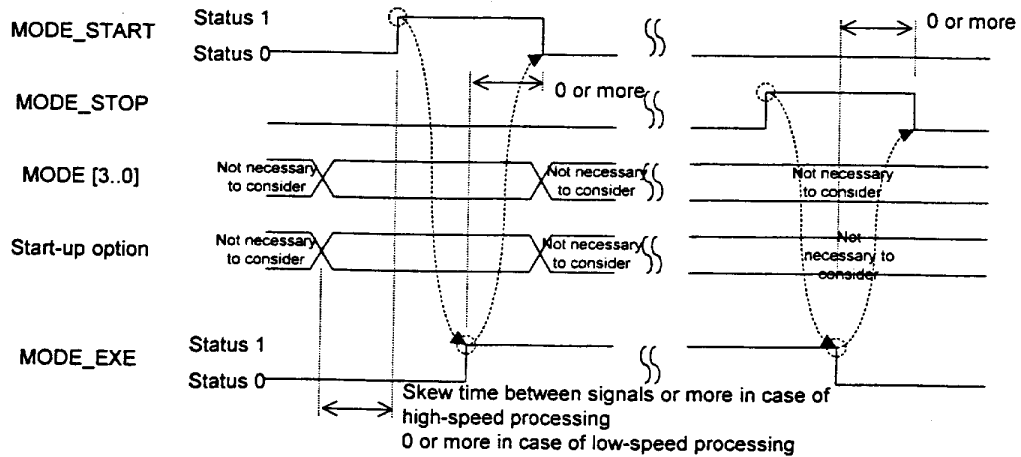

[Non-end type]

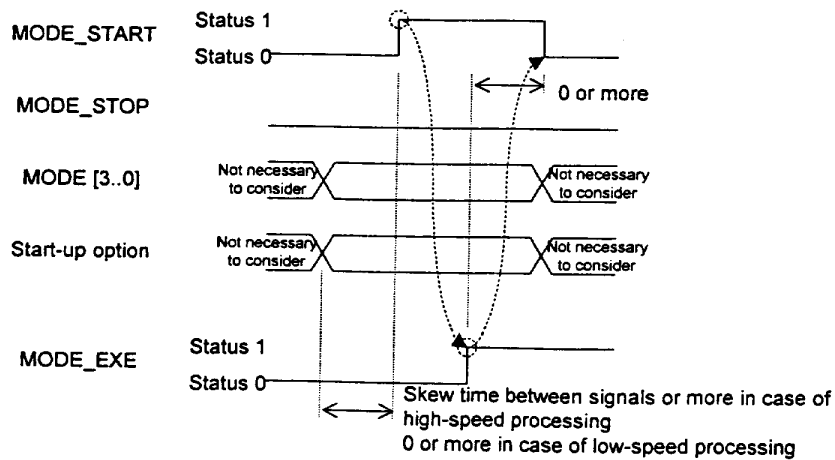

[Start-up option at program operation]

The program number to be started at program operation is provided by the I-CODE [7..0] code entry. In a setting where it is properly read as a BCD code, the program with the set number is executed from the top. In a setting where it is not properly read as a BCD code, the program with the stored execution program number is executed from the block with the stored block number.

[Start-up options at index Type A operation and index Type B operation]

In index Type A and B operations, the index number is provided by the I\_CODE [7..0] code entry and the SIGN\_INDEX sign entry at index operation, the choice between absolute or incremental move is provided by the ABS\_STR\_OPT ABS/INC start-up option entry, and the moving direction option is provided by ROTDIR\_STR\_OPT [1..0].

I\_CODE [7..0] must be set so that it can be read properly as a BCD code. When SIGN\_INDEX is the in status 1, the value read by I\_CODE [7..0] is treated as a negative value, and when in the status 0, treated as a positive value. In case of an incremental move the value is treated as a value relative to the current operation command value and in case of an absolute move, it is treated as the target operation command value.

ABS\_STR\_OPT indicates an absolute move in the status 1 and an incremental move in the status 0. When the #104 ABS/INC setting during table index operation parameter is set to *start-up option dependence*, the option specification given by ABS\_STR\_OPT is invalid.

ROTDIR\_STR\_OPT [1..0] indicates Type 0 when 0 or 3 is provided by binary code, Type 1 when 1 is provided, and Type 2 when 2 is provided. When the #105 moving direction option for rotational coordinates parameter is set to *start-up option dependence*, the option specification given by ROTDIR\_STR\_OPT [1..0] is invalid.

[Related parameters]

#104	ABS/INC setting during table index operation
#105	Moving direction option for rotational coordinates

[Start-up option at table reference operation]

In table parameter operations, the table entry is provided by the I\_CODE [7..0] code entry, the choice between an absolute and incremental move is provided by the ABS\_STR\_OPT ABS/INC start-up option entry, and the moving direction option is provided by ROTDIR\_STR\_OPT [1..0].

I\_CODE [7..0] must be set so that it can be read properly as a BCD code. The table data value and option are obtained based on the specified number. The value of the obtained table data is treated as a value relative to the current operation command value in case of an incremental move and in case of an absolute move it is treated as the target operation command value.

ABS\_STR\_OPT indicates an absolute move in the status 1 and an incremental move in the status 0. When the #104 ABS/INC setting during table index operation parameter is set to *start-up option dependence*, the option specification given by ABS\_STR\_OPT is invalid.

ROTDIR\_STR\_OPT [1..0] indicates Type 0 when 0 or 3 is provided by binary code, Type 1 when 1 is provided, and Type 2 when 2 is provided. When the #105 Moving direction option for rotational coordinates parameter is set to *start-up option dependence*, the option specification given by ROTDIR\_STR\_OPT [1..0] is invalid.

[Related parameters]

#104	ABS/INC setting during table index operation
#105	Moving direction option for rotational coordinates

Note: Regarding the moving direction in rotational coordinates

- Type0 Proximity rotational move (multiple rotations are not allowed).
- Type1 Does not cross the rotational coordinate's home position (multiple rotations are not allowed).
- Type2 Calculates the target position relative to the current rotational coordinate's home position and determines the direction (multiple rotations are allowed).

## (5) Abort (ABORT)

An operation abort command, ABORT, stops any operation other than a jog move. It functions irrespectively of the operation mode.

The operation abort command is issued as the status 1.

Unlike MODE\_STOP, the operating action stop command, the motor immediately decelerates and stops and ends the operation even during an operation involving movement. In case the M function is being executed, the execution is aborted and the operation is stopped.

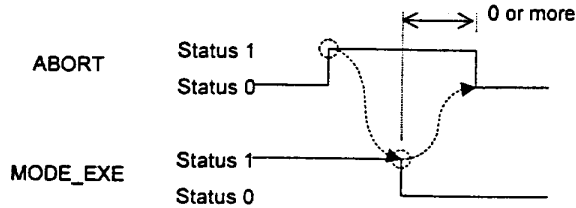

## (6) Error reset (ERR\_RESET)

The error reset command, ERR\_RESET, cancels an error status in the driver. It functions irrespectively of the operation mode. It can only be executed while in the idle status.

The error reset command is issued as the status 1.

Depending on the error content, there are errors that cannot be canceled or errors that cause identical errors immediately after canceling. Avoid creating a program that maintains ERR\_RESET and waits until ERR, the error status output, is canceled.

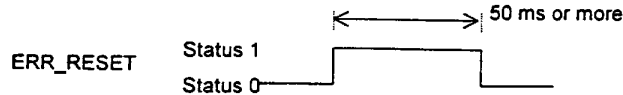

## (7) Interlock and velocity override selection (INTERLOCK OVERRIDE\_SEL)

Both the interlock command INTERLOCK and the velocity override selection OVERRIDE\_SEL select a velocity override value of the driver. They function irrespectively of the operation mode.

The relationship between the INTERLOCK and OVERRIDE\_SEL status and the velocity override value can be seen in the table below.

Interlock INTERLOCK	Velocity override selection OVERRIDE_SEL	Selected velocity override value
Status 0	Status 0	#16 Velocity override percentage 1
	Status 1	#17 Velocity override percentage 2
Status 1	Status 0	0
	Status 1	

[Related parameters]

#16	Velocity override percentage 1
#17	Velocity override percentage 2

(8) Program auto-rewind (PRG\_REWIND)

The program auto-rewind PRG\_REWIND is a signal that specifies whether or not to repeat the program from the top block when the execution of the last block of the program is completed in program operation. If the program is repeated, it also monitors the signal status each time execution of the last block is completed and judges whether or not to repeat again. It functions irrespectively of the operation mode. The program is repeated if the status of the signal is 1.

(9) Integral position control operation inhibition (POS\_INH)

The integral position control operation inhibition POS\_INH is a signal that prohibits the integral operation at the position control part. It can be issued via the PLC interface when the setting of the operation mode has given the main operation authority to the PLC interface. Integral operation is inhibited in the status 1 and allowed in the status 0.

(10) Function (M\_ANS, M\_EN, O\_CODE [7..0])

The *M function* operates under the PLC interface when the #102 *Enabling the selection of RS232C for the M function interface* parameter is set in such a way that the M function communicates with the host device via the PLC interface. See Section 5.7, "M Function" for details about the M function. The notification from the driver takes place through the use of M\_EN and O\_CODE [7..0]. In O\_CODE [7..0], the M function is expressed by a two-digit BCD code. It notifies that an M code is issued by setting M\_EN to the status 1. The host device connected via the PLC interface, upon detecting the notification of the M code from the driver, performs the necessary processing on its own side, then responds to the driver by setting M\_ANS to the status 1. The driver sets M\_EN to 0 when receiving this response. Hereafter, the driver detects when M\_ANS is set to the status 0 and completes the rest of the M function interface. O\_CODE [7..0] is a shared property of the M function and error code request function; when the error code request function is being executed, the M function is in the wait status.

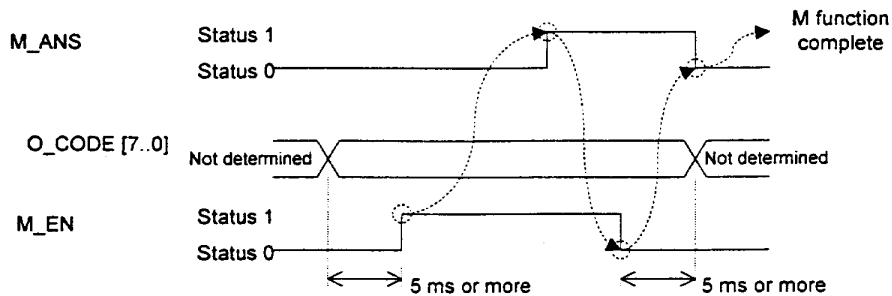

## 6 Control Interfaces

### (11) Jog move command (JOG\_UP and JOG\_DN)

A jog move command via the PLC interface functions in the idle status when the #217 *Jog move operation: RS232C selection* parameter is set so that operations are performed via the PLC interface.

A jog move is executed by JOG\_UP and JOG\_DN as explained in the table below.

In the idle status, a jog move is executed according to the command as it is. If a start command is issued during the jog move, the jog move is immediately decelerated and stopped, after which the operation is started. After that, when the operation ends, the jog move is performed according to the jog move command after stopping.

Jog (-) command JOG_DN	Jog (+) command JOG_UP	Jog move command
Status 0	Status 0	Stop command
	Status 1	(+) direction move command
Status 1	Status 0	(-) direction move command
	Status 1	Stop command

## 6.2.4 Operation 2

This section explains operations unique to the contact I/O interface.

### (1) Error code request function (ERRCODE\_REQ, ERRCODE\_OUT, O\_CODE [7..0])

The error code request function operates irrespectively of the operation mode.

The error code request function starts when the host device connected to the PLC interface sets `ERRCODE_REQ` to the status 1. The driver notifies about the presence of the error code using `ERRCODE_OUT` and `O_CODE [7..0]`. In `O_CODE [7..0]`, an error code is expressed as a two-digit BCD code. It notifies that an error code is issued by setting `ERRCODE_OUT` to the status 1. If no error has occurred, the error code is output as 0. The host device sets `ERRCODE_REQ` to the status 0 upon detecting the notification of an error code from the driver. The driver detects that `ERRCODE_REQ` is set to the status 0, sets `ERRCODE_OUT` to the status 0, and completes the rest of the error code request function.

`O_CODE [7..0]` is a shared property of the M function and the error code request function; when the M function is being executed, the error code request function is in the wait status.

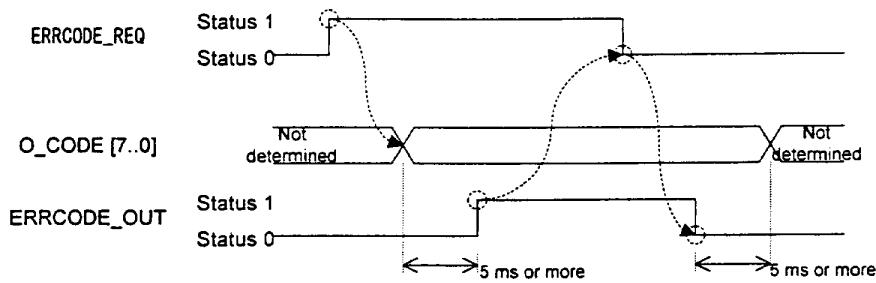



# Chapter 7

## DrvMII PC Utility

---

### 7.1 Overview

- 7.1.1 Overview of the Operation Menu
- 7.1.2 Overview of the Action Menu
- 7.1.3 Overview of the Data Management Menu

### 7.2 Installation

- 7.2.1 Installation under Windows 95/98/98SE/Me/NT4.0/2000
- 7.2.2 Starting the PC Utility

### 7.3 Preparation

- 7.3.1 Selecting a Communication Port
- 7.3.2 Selecting Channels
- 7.3.3 Displaying Communication Strings
- 7.3.4 Main Menu

### 7.4 Operation Menu

- 7.4.1 Terminal
- 7.4.2 Servo Tuning
- 7.4.3 Oscilloscope

### 7.5 Action Menu

- 7.5.1 Homing
- 7.5.2 Signal Search Move
- 7.5.3 Index Type A Operation
- 7.5.4 Index Type B Operation
- 7.5.5 Table Reference Operation
- 7.5.6 Jog Move

### 7.6 Data Management Menus

- 7.6.1 Parameter Manager
- 7.6.2 Program Manager
- 7.6.3 Index Menu
- 7.6.4 Point Set
- 7.6.5 Parts
- 7.6.6 I/O Set



## 7.1 Overview

The DrvMII PC Utility consists of three components that are accessed from the following menus: “*operation menu*,” “*action menu*,” and “*data management menu*.”

### 7.1.1 Overview of the Operation Menu

The operation menu contains the following three functions :

- **Terminal:**  
This menu allows you to send and receive character strings to/from the M2 driver (hereinafter referred to as the “driver”), monitor parameters/monitors as well as errors/alarms, and use parameter/command help.
- **Servo control:**  
This menu allows you to adjust the servo parameters of the motor through auto-tuning and manual tuning. It also allows you to adjust various compensation filters.
- **Oscilloscope:**  
This function displays graphs of time-series of parameter/monitor values.

### 7.1.2 Overview of the Action Menu

In the action menu, you can set and display parameters, display monitors, and start or stop actions related to the operations listed below.

“*Homing move*,” “*signal search move*,” “*index Type A operation*,” “*index Type B operation*,” “*table reference operation*,” and “*jog move*.”

### 7.1.3 Overview of the Data Management Menu

The data management menu contains the following seven functions:

- **Parameter:**  
This function allows you to save all the parameters to files and register them from files. It also allows you to edit the machine setting parameters.
- **Program:**  
This function allows you to edit, register, and save the programs necessary for “program operation.” In addition, you can start or stop a program and monitor the program block currently being executed.
- **Index compensation:**  
This function allows you to edit, register, and save data necessary for “index Type A operation” and “index Type B operation.”
- **Point set:**  
This function allows you to edit, register, and save data necessary for “table reference operation.”
- **Parts:**  
This function allows you to edit (universal cam), register, and save parts necessary for cam profile moves.
- **I/O set:**  
This function allows you to set the logical setting of I/O points.
- **Absolute precision compensation:**  
This function allows you to edit, register, and save absolute precision compensation data.  
(This setting is valid if the absolute precision option is set to “yes,” with which the absolute precision of the motor is compensated for the entire circumference.)

## 7.2 Installation

### 7.2.1 Installation under Windows 95/98/98SE/Me/NT4.0/2000

The DrvMII utility (hereinafter referred to as the “PC utility”) runs on Windows 95, 98, 98SE, Me, NT4.0 and 2000. It can be installed via “Add/Remove Programs” under the “Control Panel” in Windows. If an older version of the PC utility is present, delete it first and then install the new version.

Display the “Properties of Adding/Removing Programs” dialog box and click “Set Up (1).” Then proceed according to the instructions displayed on the screen. The PC utility setup program starts up.

Proceed with the setup according to the instructions on the screen. A dialog box for determining the directory in which to install the PC utility appears (see Figure 7.1).

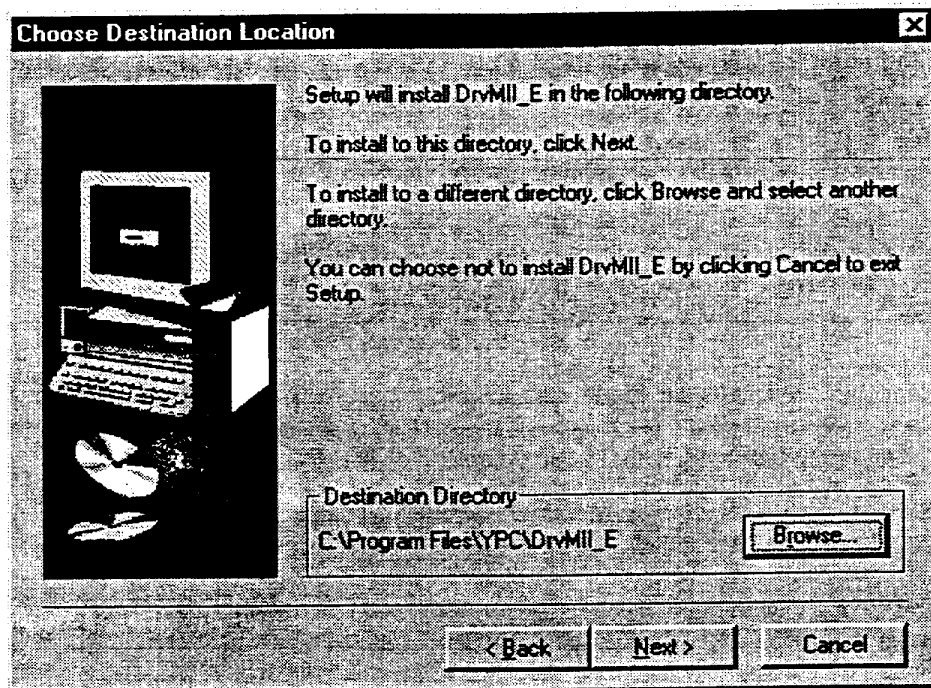

Figure 7.1 “Choose Destination Location” dialog box

Click “Browse” to display the “Select Directory” dialog box and select the desired drive and directory. Click “Next” to display “Select Program Folder” (see Figure 7.2).

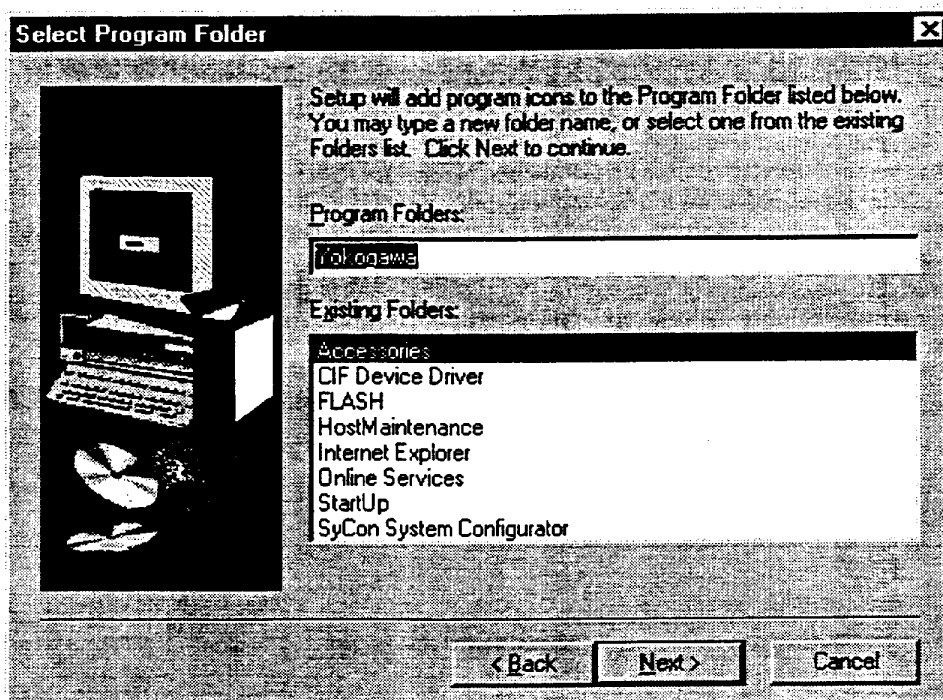

Figure 7.2 "Select Program Folder" dialog box

Select a program folder and click "Next." The installation begins. Follow the instructions on the screen and change disks. When the setup is completed, the "Setup Complete" dialog box appear (see Figure 7.3).

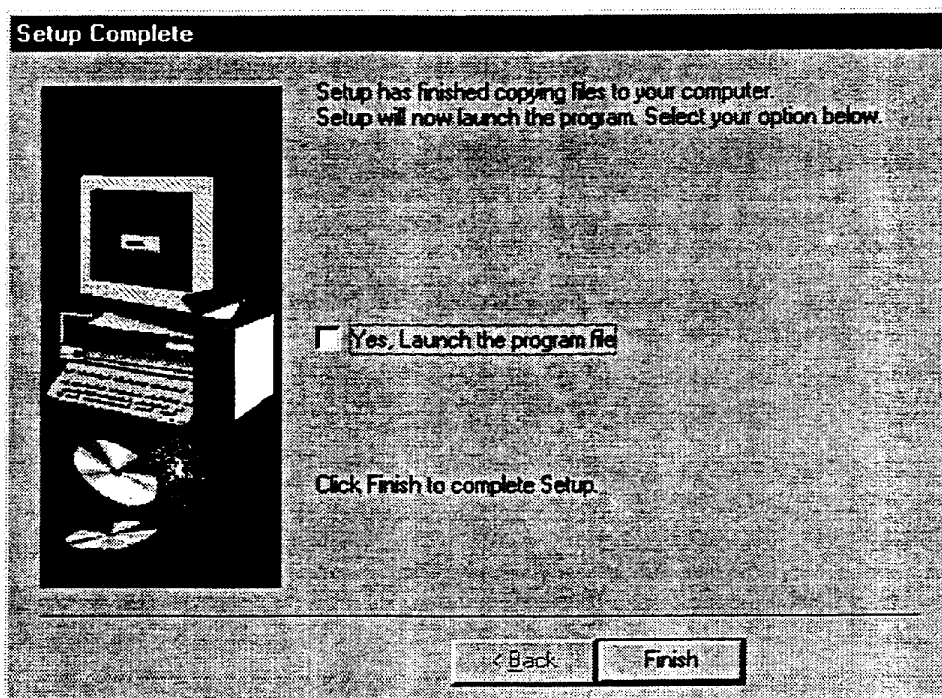

Figure 7.3 "Setup Complete" dialog box

To start the program, select "Launch program file" and click "Finish." If you do not want to start the program, just click "Finish." If you are prompted to restart the computer, simply follow the message and restart it.

## 7.2.2 Starting the PC Utility

In order to start the PC utility under Windows, click the “Start” button, “Program,” “Specified program folder,” and then “YOKOGAWA\_E” The “Opening” dialog box (see Figure 7.4) is displayed for several seconds, and the PC utility starts up. (By default, the specified program folder is “YOKOGAWA\_E”)

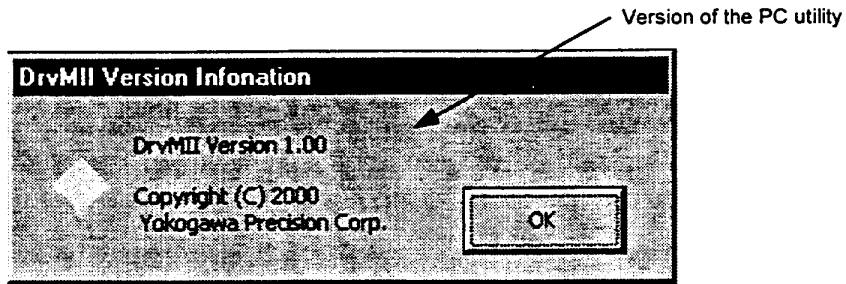

Figure 7.4 “Opening” dialog box

## 7.3 Preparation

Connect the serial port of the PC with the serial port of the driver with a dedicated cable.  
(Do not use commercial off-the-shelf cables. There is a terminal for which 5V is output from the driver for connecting with the teaching box.)

### 7.3.1 Selecting a Communication Port

When you start the PC utility, the “ComPortSelect” dialog box appears in the left side of the screen (see Figure 7.5). Change the setting according to the communication port of the connected PC.

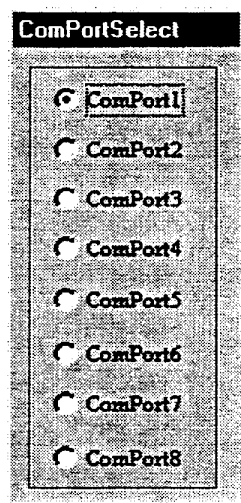

Figure 7.5 “ComPortSelect”

Note: Settings made in the “ComPortSelect” dialog box are stored in a file. It is not necessary to make settings from the next time you start the PC utility. Change the setting as necessary.

### 7.3.2 Selecting Channels

When you start the PC utility, the “Communication mode” dialog box appears in the upper left corner of the screen (see Figure 7.6). If you are using one driver, select a single channel, and if you are using multiple drivers, select multi-channel addresses. (See Chapter 5 for how to make setting on the driver side.)

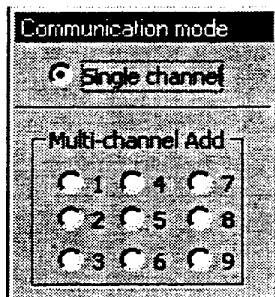

Figure 7.6 “Communication mode”

Note: The settings made in the “Communication mode” dialog box are not stored. When the PC utility is started up, a single channel is always set.

### 7.3.3 Displaying Communication Strings

When you start the PC utility, the "Communication string" dialog box appears in the upper right corner of the screen. (See Figure 7.7.) Any strings that the PC utility sends to the driver as well as any strings received from the driver are displayed regardless of the menu.

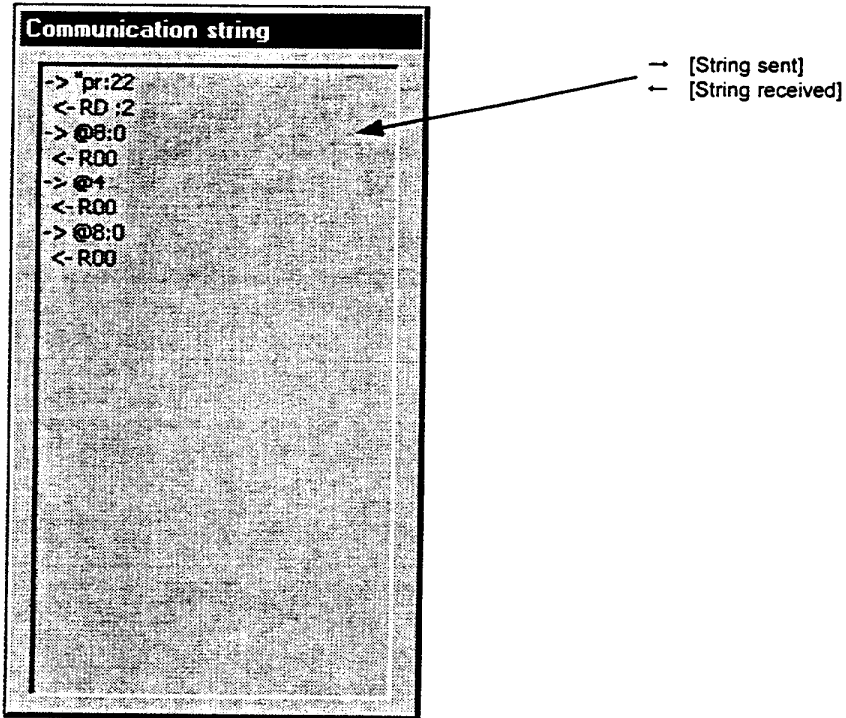

Figure 7.7 "Communication string"

## 7.3.4 Main Menu

When you start the PC utility, the “MainMenu” dialog box appears (see Figure 7.8). See the following chapters for how to start the actual operation.

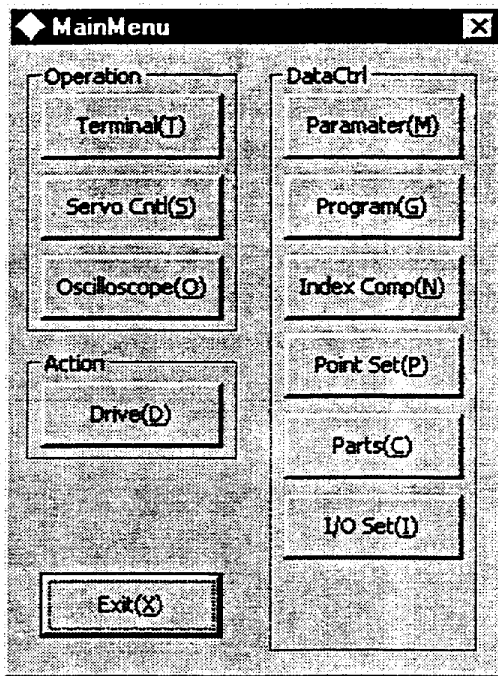

Figure 7.8 "MainMenu" dialog box

## 7.4 Operation Menu

### 7.4.1 Terminal

Using this menu, you can send and receive character strings to/from the driver, monitor parameters/monitors as well as errors/alarms, and use parameter/command help.

Click "Terminal (T)" under "MainMenu" to display the "Terminal" dialog box (see Figure 7.9).

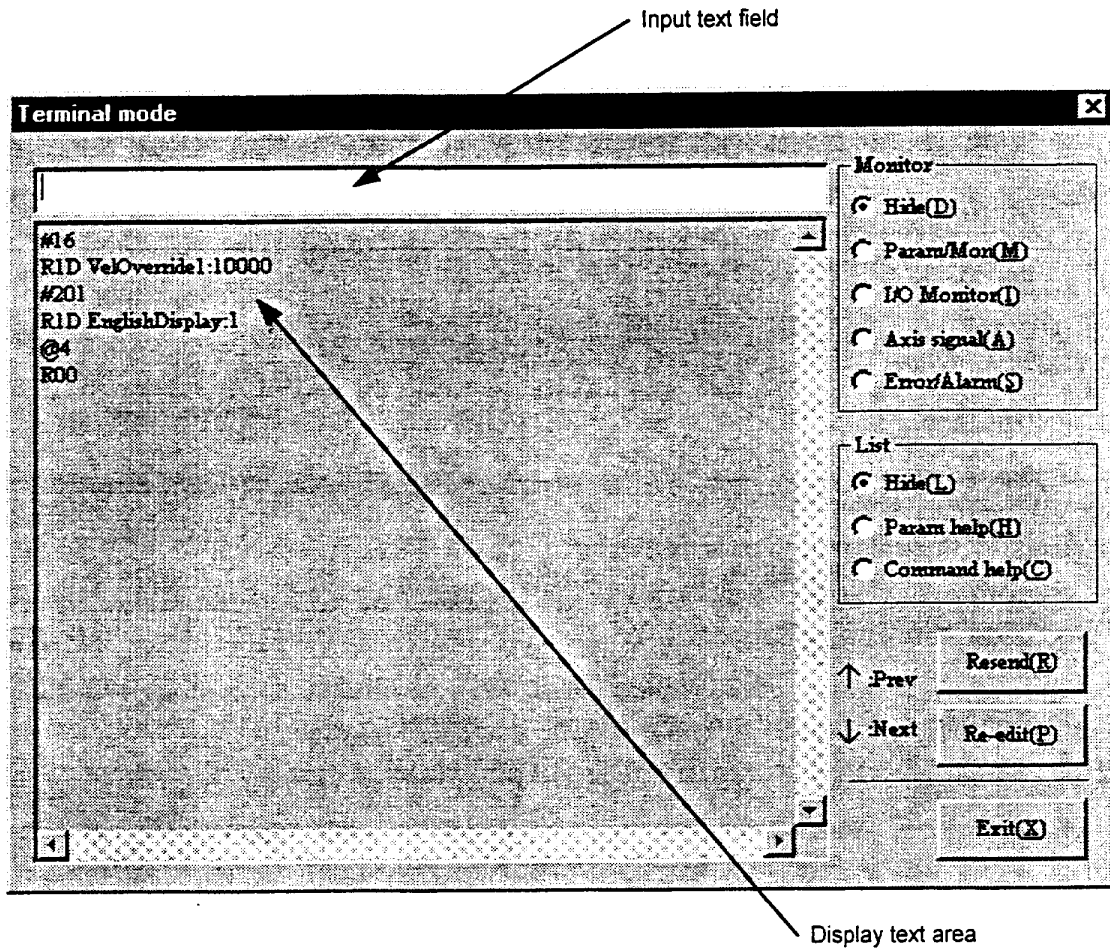

Figure 7.9 "Terminal" dialog box

#### [Sending/receiving character strings]

- 1) Enter a character string in the input text field and press the Enter (Return) key. The character string is sent to the driver and, at the same time, displayed in the display text area.
- 2) When a character string is received from the driver, it is displayed in the display text area.
- 3) If you click "Resend," the character string transmitted last time is sent again.
- 4) If you click "Re-edit," the character string transmitted last time is displayed in the input text field.
- 5) It is possible to display a maximum of ten transmitted character strings in the order of transmission in the input text field by pressing the ↑ arrow key on the PC keyboard. By pressing the ↓ arrow key, the character strings displayed by pressing the ↑ arrow key can be displayed in the reverse order.



## (1) Parameter/monitor

In the “Terminal” menu, click “*Parameter/Monitor (M)*” under “Monitor” to display the “Parameter/Monitor” dialog box (see Figure 7.10).

If the number of a parameter/monitor you want to monitor is entered in the parameter/monitor number text field, the contents and values of the corresponding parameters are displayed. Up to five parameters/monitors can be monitored, and they can be switched on and off by clicking their respective switch check boxes (the update cycle of the parameter/monitor values can be shortened by decreasing the number of parameters to be monitored).

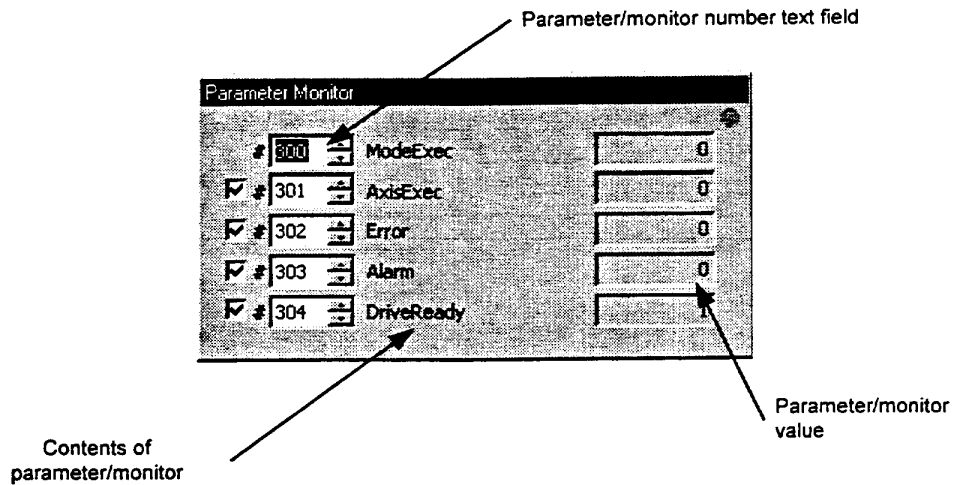

Figure 7.10 “Parameter Monitor” dialog box

(2) I/O monitor

In the "Terminal" menu, click "I/O Monitor (I)" under "Monitor" to display the "I/O Monitor" dialog box (see Figure 7.11).

Via the "I/O monitor" dialog box, it is possible to monitor the on/off status of DI and DO points. The number of DI/DO points that can be monitored at the same time is set to 32/32. If you are using an interface where the number of DI/DO points is greater than 32/32, the ones you wish to monitor should be chosen from among the available options.

If the driver is started up in the DI emulation status, the DI points can be turned on/off directly using the buttons in the lower part of the dialog box. (Even if the displayed DI/DO points are changed by choosing from among the available options, the status of the DI point, once set, is maintained.)

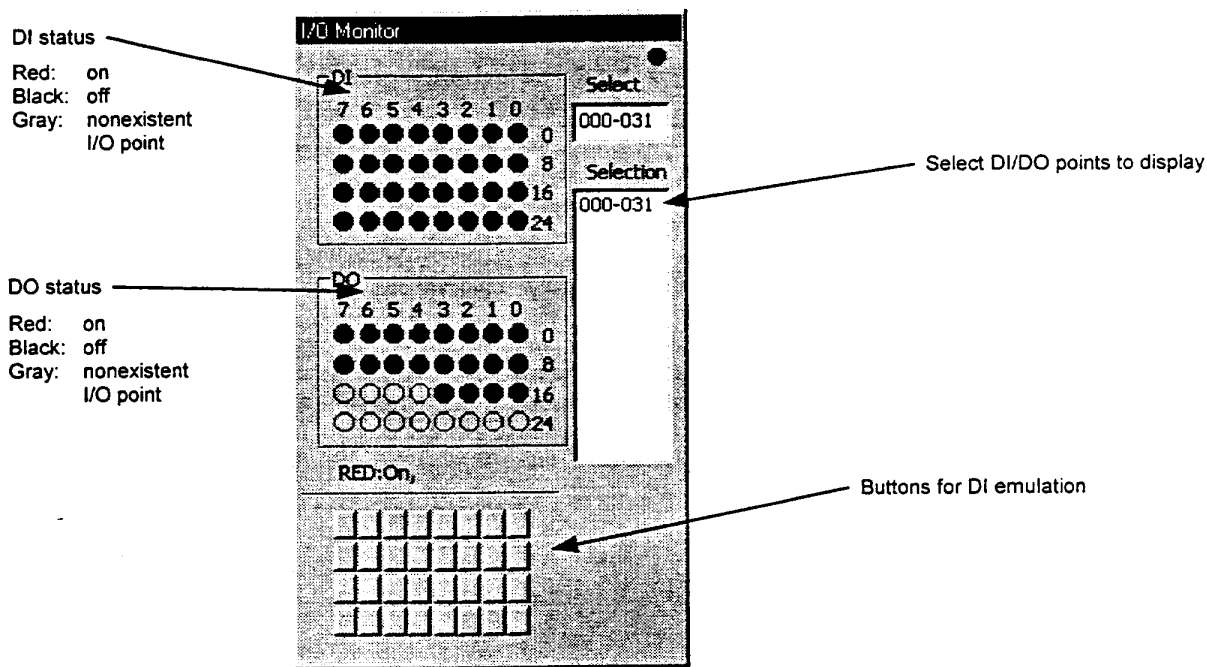

Figure 7.11 "I/O Monitor" dialog box

# 7 DrvMII PC Utility

### (3) Axis signal status display

In the “Terminal” menu, click “*Axis signal status (A)*” under “Monitor” to display the “Axis signal status” dialog box (see Figure 7.12).

Via the “Axis signal status” dialog box, it is possible to monitor the axis status, etc. of the driver.

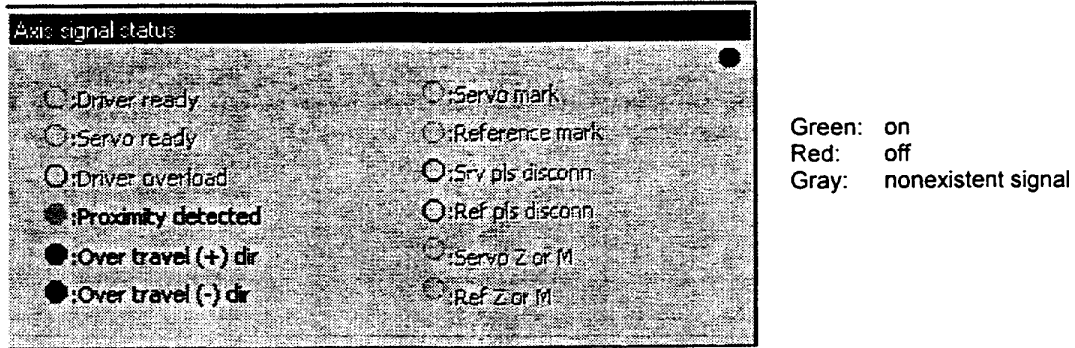

Figure 7.12 “Axis signal status” dialog box

### (4) Error or alarm monitor

In the “Terminal,” click “*Error or Alarm (S)*” under “Monitor” to display the “Error or Alarm” dialog box (see figure 7.13).

When an error occurs, this dialog box displays “error message” and shows the error history in the display text area. When an alarm occurs, it displays “alarm message” and shows the alarm history in the display text area. In the display text area, the error history is displayed first, and a maximum of 16 errors/alarms is displayed.

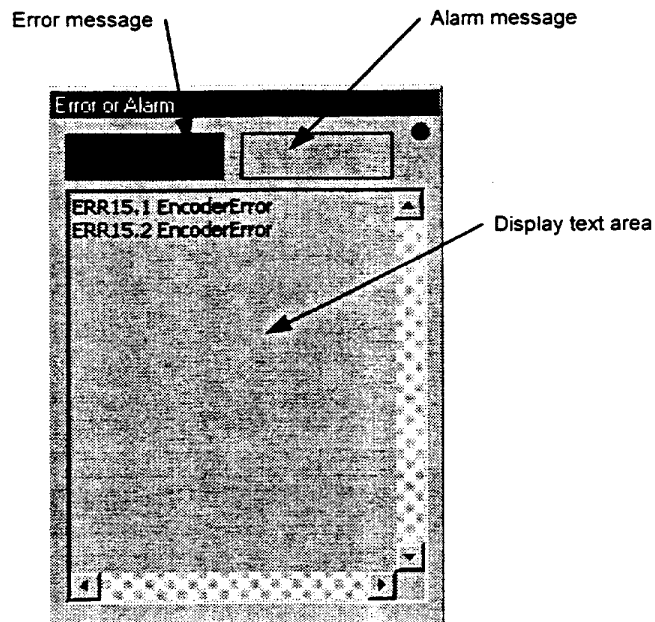

Figure 7.13 “Error or Alarm” dialog box

(5) Parameter/monitor help

In the "Terminal" menu, click "*Parameter/Monitor help (H)*" under "List" to display the "Parameter/Monitor help" dialog box (see Figure 7.14).

The Parameter/Monitor help can display the contents of a maximum of ten parameters/monitors. If you click "*Prev (P)*," parameters/monitors with smaller numbers than the currently displayed parameters/monitors are displayed. If you click "*Next (N)*," parameters/monitors with larger numbers than the currently displayed parameters/monitors are displayed.

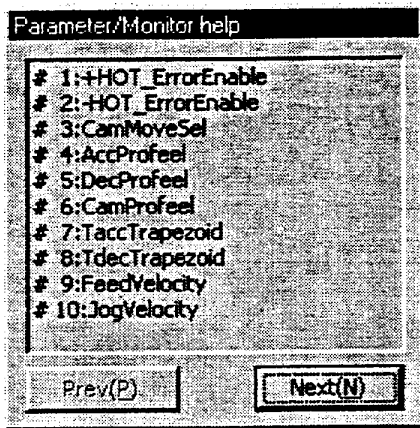

Figure 7.14 "Parameter/Monitor help" dialog box

(6) Command help

In the "Terminal" menu, click "*Command Help (C)*" under "List" to display the "Command Help" dialog box (see Figure 7.15).

The Command Help can display the contents of a maximum of ten commands. If you click "*Prev (P)*," commands with smaller numbers than the currently displayed commands are displayed. If you click "*Next (N)*," commands with larger numbers than the currently displayed commands are displayed.



Figure 7.15 "Command Help" dialog box

### 7.4.2 Servo Tuning

This menu allows you to adjust the servo parameters of the motor through auto-tuning and manual tuning in addition to adjust various compensation filters

Click "Servo Cntl (S)" on "MainMenu" to display the "Servo Tuning" dialog box.

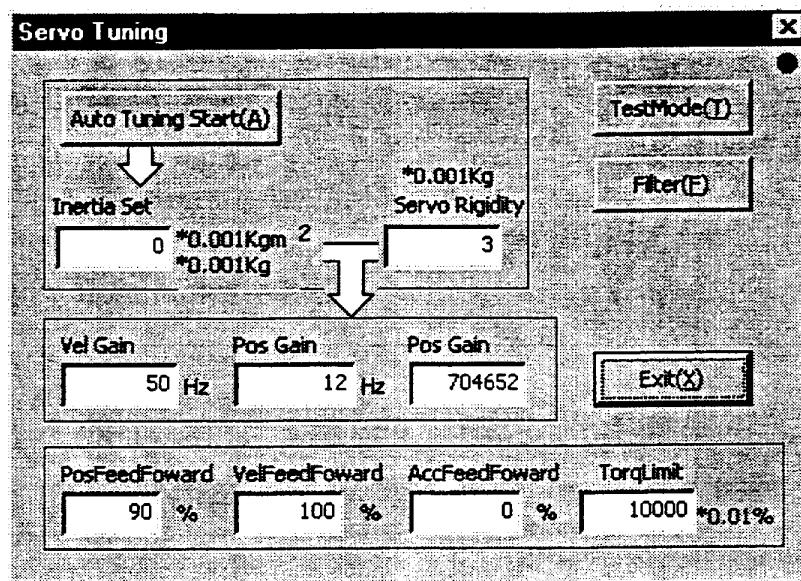

Figure 7.16 "Servo Tuning" dialog box

#### (1) Auto-tuning

- 1) Change the main operation mode to the RS232C main operation mode (see Chapter 5).
- 2) Set the motor to Servo ON (the operations until this point must be made before opening the "Servo Tuning" dialog box.)
- 3) Click "Auto Tuning (A)" to start the auto-tuning.

Note: The motor performs reciprocating movements in order to estimate the inertia and weight of the load (the operation width of the reciprocating movement can be changed in parameter <#32>). Please make sure that there are no interfering objects within the range of the operation width.

- 4) After performing reciprocating movement for several times, the estimation of the inertia and weight is completed and reflected in the parameter for inertia/weight.
- \* By changing the servo stiffness setting parameter, three parameters – the velocity control bandwidth, position control bandwidth, and position control integral limiter – are changed and thus the servo stiffness changes.

#### (2) Manual tuning

- 1) Change the main operation mode to the RS232C main operation mode (see Chapter 5).
  - 2) Set the motor to Servo ON (the operations until this point must be made before opening the "Servo Tuning" dialog box.)
  - 3) Click "Test Mode (T)" to enter the test mode.
- Note: The motor performs small width reciprocating movements (the operation width of the reciprocating movement can be changed in parameter <#32>). Please make sure that there are no interfering objects in the range of the operation width.
- 4) In the test mode, the driver monitors the waveform of the motor position by oscilloscope, etc., and manipulates three parameters – the velocity control bandwidth, position control bandwidth, and position control integral limiter – to tune the servo (see Chapter 5 for more details).

[Other parameters]

- \* The three parameters – position feed forward, velocity feed forward, and acceleration feed forward – have no relation with servo stiffness. They are parameters for adjusting the settling time decrease.
- \* The torque limiter parameter should be changed when limiting the motor torque.

(3) Filter setting

Click "Filter (F)" under "Servo Tuning" to display the "Filter" dialog box (see Figure 7.17). The filter setting is divided into two sections, a first order delay filter setting and a notch filter setting.

- 1) To set the first order delay filter: Select one from None, 20/80, 30/120, and 40/160.
  - 2) To set the notch filter: Manipulate the frequency setting scroll bar and set.
    - Clicking the arrows at either end: The frequency changes in steps of one.
    - Clicking between the slider bar and an arrow: The frequency changes in steps of ten.
    - Dragging the slider bar: The frequency is set to the value at the position to which the slider bar is moved.
- \* Refer to Chapter 5 for how to use the filters.

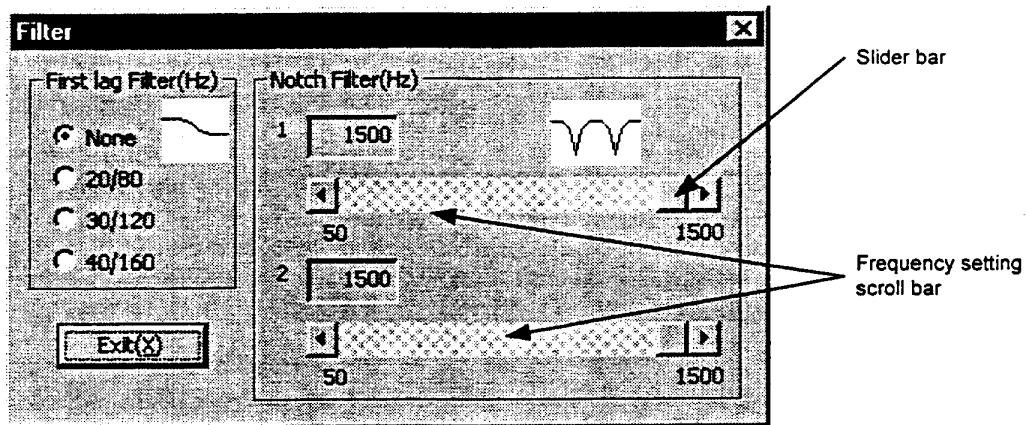

Figure 7.17 "Filter" dialog box

# 7 DvMII PC Utility

## 7.4.3 Oscilloscope

The oscilloscope displays time-series of parameter/monitor values.

Click "Oscilloscope (O)" under "MainMenu" to display the "Oscilloscope" dialog box.

Note: The parameter/monitor information is obtained automatically from the driver when the PC utility is started. Please wait for a while until it can be used. (This operation is required only once for the initial use.)

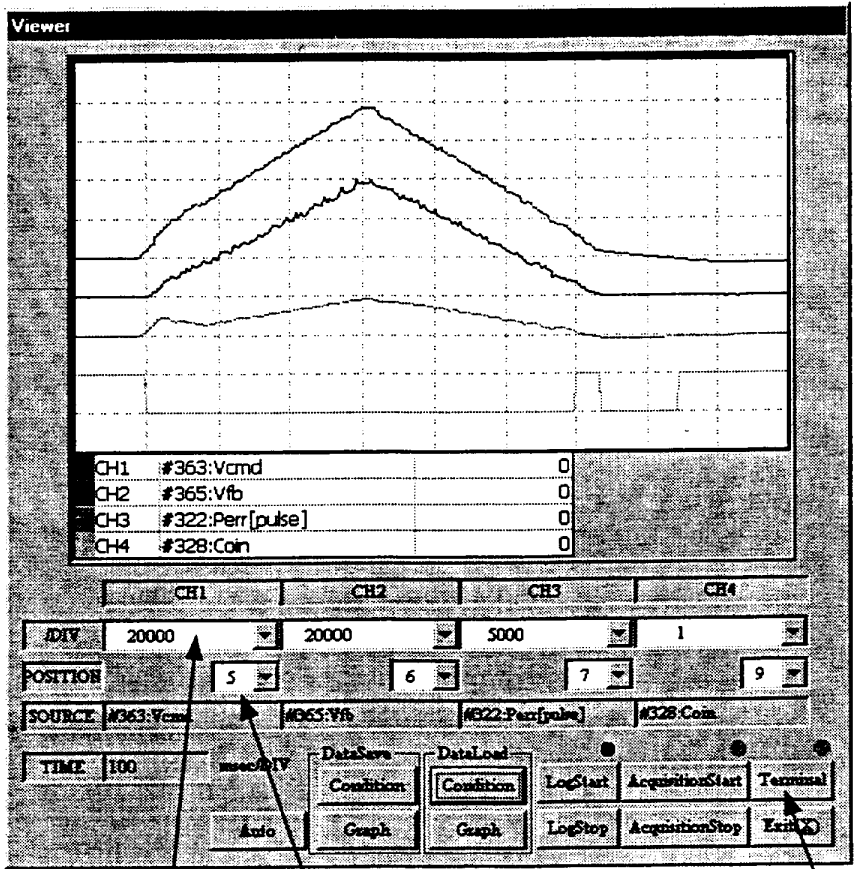

12) Vertical axis range selection

12) Display position selection

Simplified terminal

Figure 7.18 "Oscilloscope" dialog box

[How to use the oscilloscope]

- (1) Click "Log Start" on the "Oscilloscope" dialog box to display the "SetCondition/ELogStart" dialog box (see Figure 7.19).

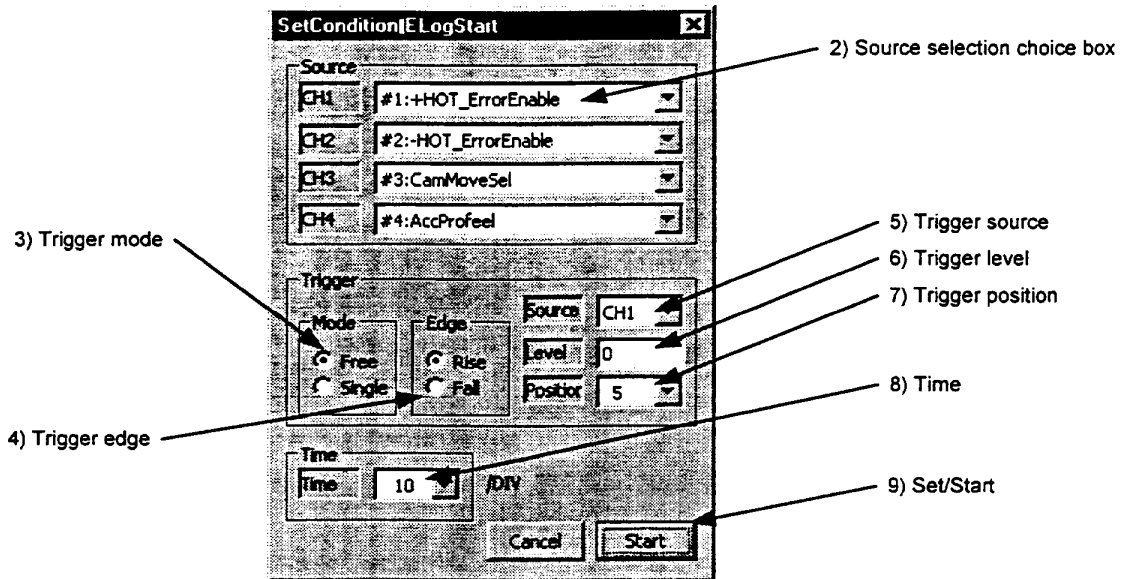

Figure 7.19 "SetCondition/ELogStart" dialog box

- (2) Click the ↓ to select the parameters/monitors you want to display in the "source selection choice box." (CH1 to CH4)
- (3) Select a trigger mode.  
Free: Obtains data immediately without using the trigger.  
Single: Obtains data when the trigger conditions are met.
- (4) Select a trigger edge. (Valid when the trigger mode is Single.)
- (5) Click the ↓ to select a trigger source. (Valid when the trigger mode is Single.)
- (6) Enter a trigger level. (Valid when the trigger mode is Single.)
- (7) Click the ↓ to select a trigger position. (Valid when the trigger mode is Single.)
- (8) Click the ↓ to select a time (horizontal axis). (The unit is msec.)
- (9) Click "Set/Start" to return to the "Oscilloscope" dialog box and wait for the completion of data acquisition.
- (10) When the data is obtained, "Start Acquisition" becomes active.
- (11) Click "Start Acquisition" to extract data from the driver and display it in the "Oscilloscope" dialog box.

Note: If the set trigger conditions are not satisfied and "Start Acquisition" does not become active, click "Log Stop" and set the trigger conditions again.



- (12) The displayed waveform can be reshaped using "Display position selection" and "Vertical axis range selection" in the "Oscilloscope" dialog box.  
When "Auto" is clicked at this time, the "Display position selection" value is changed to "5," and the "Vertical axis range selection" value is changed automatically to a value that enables to display the entire waveform as much as possible without cutting any part of the waveform.
- (13) When "Condition and display" under "Data save" is clicked, the status set in the "SetCondition/ELogStart" dialog box as well as the values set by "Display position selection" and "Vertical axis range selection" can be saved by assigning a file name.  
In addition, when "Graph" under "Data save" is clicked, the waveform currently being displayed, the status set in the "SetCondition/ELogStart" dialog box, and the values set by "Display position selection" and "Vertical axis range selection" can be saved by assigning a file name.
- \* The status set in the "SetCondition/ELogStart" dialog box as well as the values set by "Display position selection" and "Vertical axis range selection" are automatically saved in the "oscscope.cnd" file when the "Oscilloscope" dialog box is closed.
- (14) When "Condition and display" under "Data load" is clicked, the setting status of the "SetCondition/ELogStart" dialog box as well as the values set by "Display position selection" and "Vertical axis range selection" are loaded from files, and then displayed. The waveform is cleared at this time and all values are set to 0.  
In addition, when "Graph" under "Data save" is clicked, the waveform data, the setting status in the "SetCondition/ELogStart" dialog box, and the values set by "Display position selection" and "Vertical axis range selection" are loaded from files, and then a waveform is displayed.
- Note:** If the trigger condition that has been set cannot be established and "Start acquisition" cannot be activated, click "Log stop" and set a new trigger condition again.
- \* The simplified terminal function is provided in the "Oscilloscope" dialog box. Use this function in order to change parameter values or to start an operation.

## 7.5 Action Menu

In the operation menu, you can set and display parameters, display monitors, and start or stop actions related to the operations listed below.

*"Homing move," "signal search move," "index Type A operation," "index Type B operation," "table reference operation," and "jog move."*

Click *"Drive (D)"* under *"MainMenu"* to display the *"DriveMenu"* dialog box (see Figure 7.20).

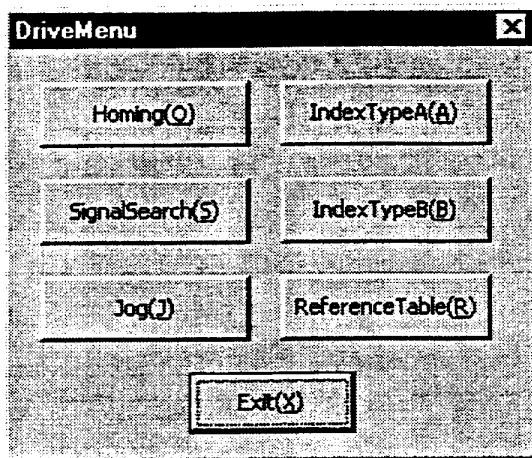

Figure 7.20 "DriveMenu" dialog box

## 7.5.1 Homing

Click "Homing (O)" in the "DriveMenu" dialog box to display the "Homing" dialog box (see Figure 7.21). If the connection with the driver is established, the current values of the related parameters are read and can be edited.

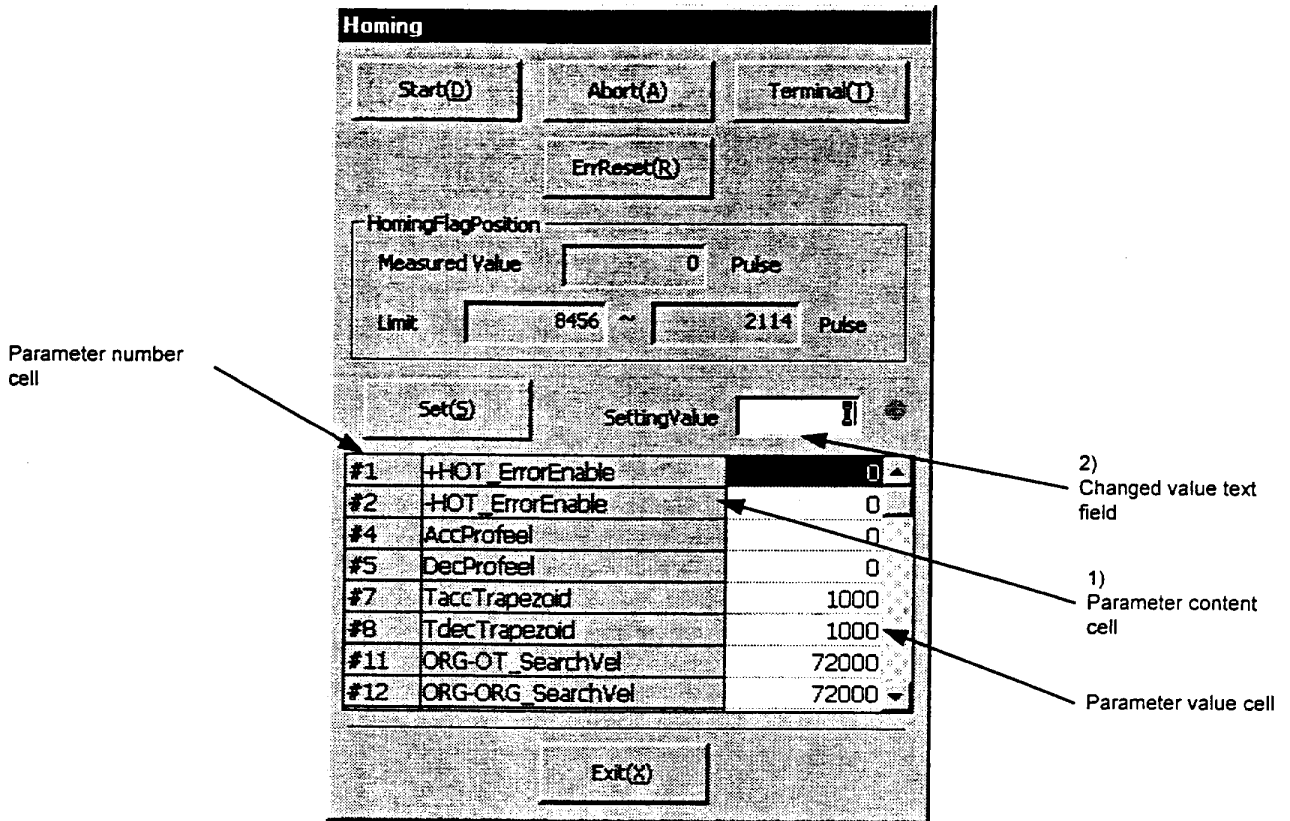

Figure 7.21 "Homing" dialog box

### (1) Editing parameters

- 1) Click the parameter content cell of the parameter to be changed. The current value is displayed in the changed value text field.
- 2) Enter a value in the changed value text field and click the Enter (Return) key or click another cell to make the new parameter value valid.
- 3) Repeat steps 1) and 2) as necessary and click "Set (S)" to set the changed values in the driver. If there is an error in the set value, a warning message is displayed and the parameter is read again. Parameters whose setting values are erroneous will not be changed; therefore the changed parameters should be verified.

## (2) Operation

Operation of the motor is possible when the main operation mode is set to the RS232C main operation mode (see Chapter 5). (In the PLC main operation mode, several buttons are disabled.)

### [Start]

- 1) Set the motor to Servo ON (see Chapter 5).
- 2) Click "*Start (D)*."  
→ The measured value of the homing is displayed after the homing operation is finished.

### [Abort]

- 1) Click "*Abort (A)*."  
→ The motor decelerates and stops.

### [Error Reset]

- 1) Click "*ErrReset (R)*."  
→ Errors that can be recovered are canceled.

### [Simplified terminal]

- 1) Click "*Terminal (T)*."
- 2) Send or receive character strings.

### 7.5.2 Signal Search Move

Click "*SignalSearch (S)*" in the "DriveMenu" dialog box to display the "Signal Search" dialog box (see Figure 7.22). If the connection with the driver is established, the current values of the related parameters are read and can be edited.

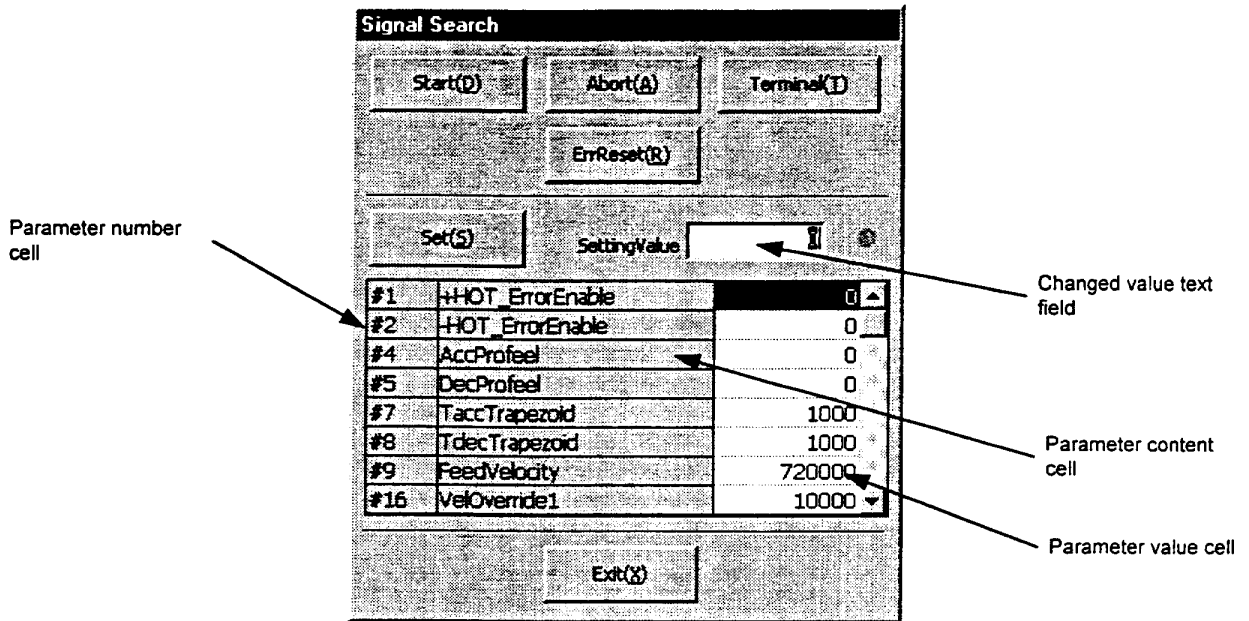

Figure 7.22 "Signal Search" dialog box

#### (1) Editing parameters

- 1) Click the parameter value cell of the parameter to be changed. The current value is displayed in the changed value text field.
- 2) Enter a value in the changed value text field and click the Enter (Return) key or click another cell to make the new parameter value valid.
- 3) Repeat steps 1) and 2) as necessary and click "Set (S)" to set the changed values in the driver. If there is an error in the set value, a warning message is displayed and the parameter is read again. Parameters whose setting values are erroneous will not be changed; therefore the changed parameters should be verified.

## (2) Operation

Operation of the motor is possible when the main operation mode is set to the RS232C main operation mode (see Chapter 5). (In the PLC main operation mode, several buttons are disabled.)

### [Start]

- 1) Set the motor to Servo ON (see Chapter 5).
- 2) Click "*Start (D)*."

### [Abort]

- 1) Click "*Abort (A)*."  
→ The motor decelerates and stops.

### [Error Reset]

- 1) Click "*ErrReset (R)*."  
→ Errors that can be recovered are canceled.

### [Simplified terminal]

- 1) Click "*Terminal (T)*."
- 2) Send or receive character strings.

## 7.5.3 Index Type A Operation

Click "Index Type A (A)" in the "DriveMenu" dialog box to display the "Index Type A" dialog box (see Figure 7.23). If the connection with the driver is established, the current values of the related parameters are read and can be edited.

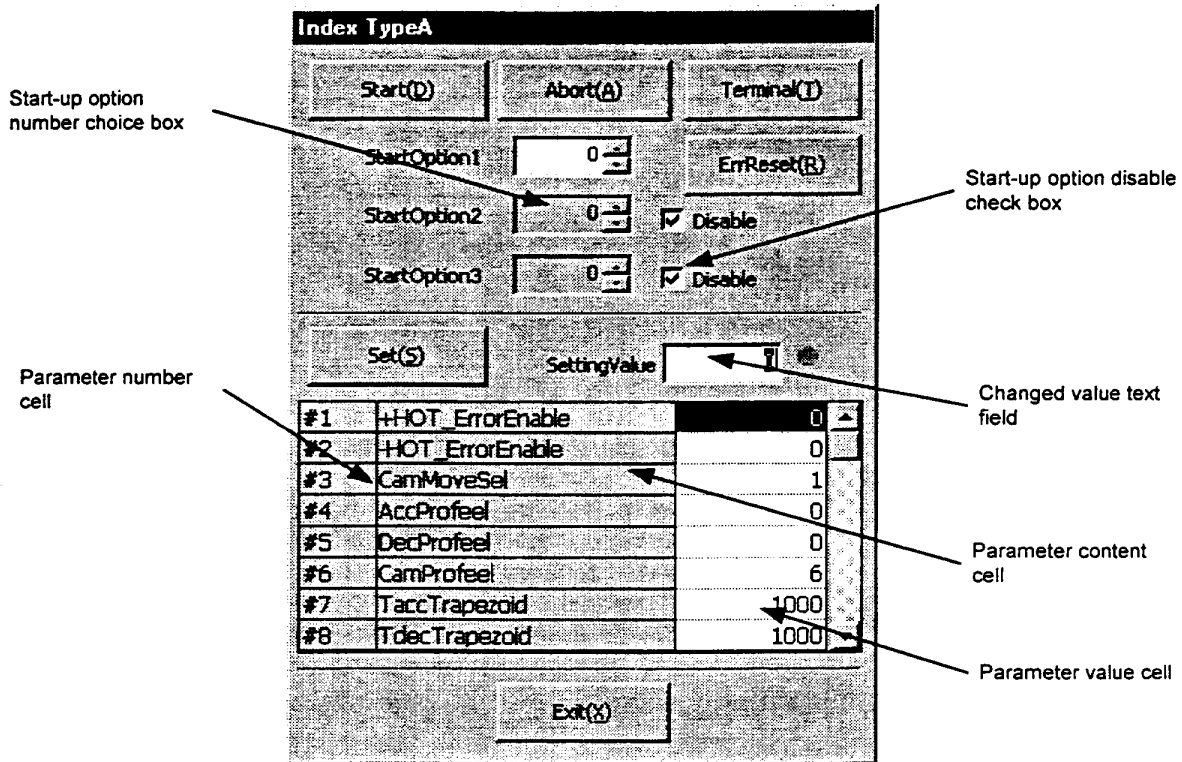

Figure 7.23 "Index Type A" dialog box

### (1) Editing parameters

- 1) Click the parameter value cell of the parameter to be changed. The current value is displayed in the changed value text field.
- 2) Enter a value in the changed value text field and click the Enter (Return) key or click another cell to make the new parameter value valid.
- 3) Repeat steps 1) and 2) as necessary and click "Set (S)" to set the changed values in the driver. If there is an error in the set value, a warning message is displayed and the parameter is read again. Parameters whose setting values are erroneous will not be changed; therefore the changed parameters should be verified.

## (2) Editing start-up options

- 1) Select the number in the start-up option number choice box for the start-up option to be changed. However, it is not possible to edit when the start-up option disable check box is set to disabled.
- 2) If start-up options are not necessary, the start-up option disable check box should be clicked to disable the start-up option number choice box. In this case, the disabled start-up options will not be set.

## (3) Operation

Operation of the motor is possible when the main operation mode is set to the RS232C main operation mode (see Chapter 5). (In the PLC main operation mode, several buttons are disabled.)

### [Start]

- 1) Set the motor to Servo ON (see Chapter 5).
- 2) Click "*Start (D)*."

### [Abort]

- 1) Click "*Abort (A)*."  
→ The motor decelerates and stops.

### [Error Reset]

- 1) Click "*ErrReset (R)*."  
→ Errors that can be recovered are canceled.

### [Simplified terminal]

- 1) Click "*Terminal (T)*."
- 2) Send or receive character strings.



### 7.5.4 Index Type B Operation

Click "*IndexTypeB (B)*" in the "DriveMenu" dialog box to display the "Index TypeB" dialog box (see Figure 7.24). If the connection with the driver is established, the current values of the related parameters are read and can be edited.

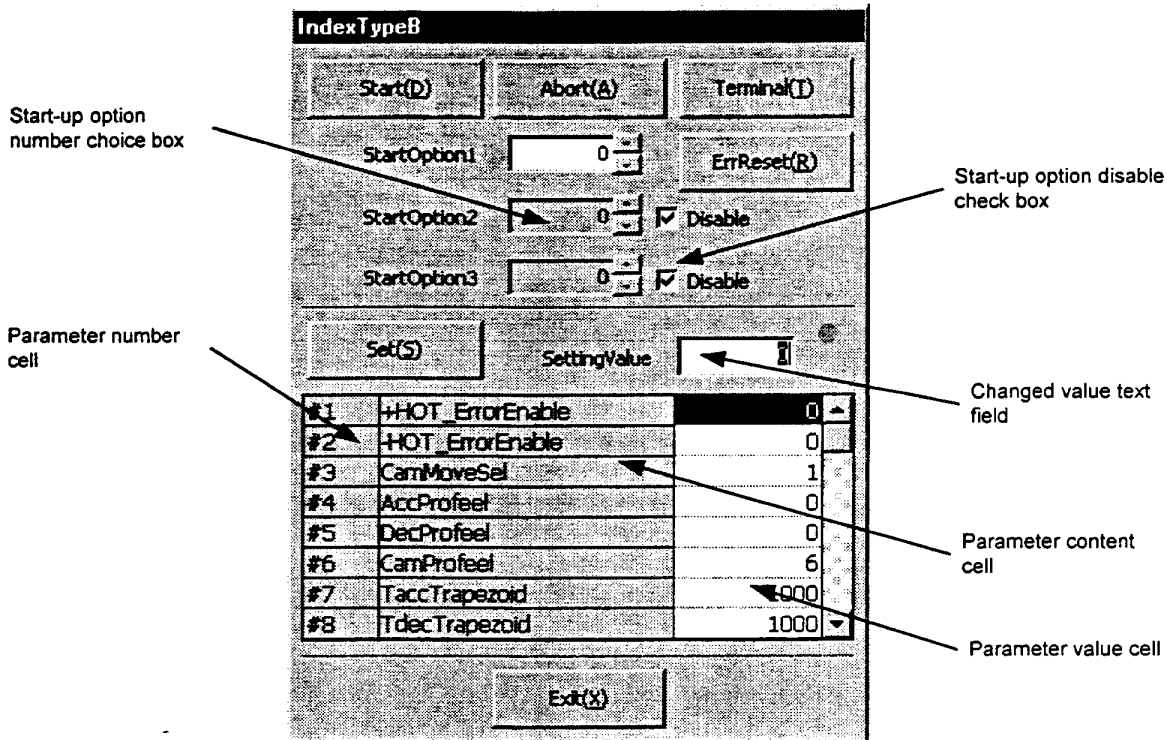

Figure 7.24 "Index TypeB" dialog box

#### (1) Editing parameters

- 1) Click the parameter value cell of the parameter to be changed. The current value is displayed in the changed value text field.
- 2) Enter a value in the changed value text field and click the Enter (Return) key or click another cell to make the new parameter value valid.
- 3) Repeat steps 1) and 2) as necessary and click "Set (S)" to set the changed values in the driver. If there is an error in the set value, a warning message is displayed and the parameter is read again. Parameters whose setting values are erroneous will not be changed; therefore the changed parameters should be verified.

## (2) Editing start-up options

- 1) Select the number in the start-up option number choice box for the start-up option to be changed. However, it is not possible to edit when the start-up option disable check box is set to disabled.
- 2) If start-up options are not necessary, the start-up option disable check box should be clicked to disable the start-up option number choice box. In this case, the disabled start-up options will not be set.

## (3) Operation

Operation of the motor is possible when the main operation mode is set to the RS232C main operation mode (see Chapter 5). (In the PLC main operation mode, several buttons are disabled.)

### [Start]

- 1) Set the motor to Servo ON (see Chapter 5).
- 2) Click "*Start (D)*."

### [Abort]

- 1) Click "*Abort (A)*."  
→ The motor decelerates and stops.

### [Error Reset]

- 1) Click "*ErrReset (R)*."  
→ Errors that can be recovered are canceled.

### [Simplified terminal]

- 1) Click "*Terminal (T)*."
- 2) Send or receive character strings.

## 7.5.5 Table Reference Operation

Click "ReferenceTable (R)" in the "DriveMenu" dialog box to display the "Reference Compensation Table" dialog box (see Figure 7.25). If the connection with the driver is established, the current values of the related parameters are read and can be edited.

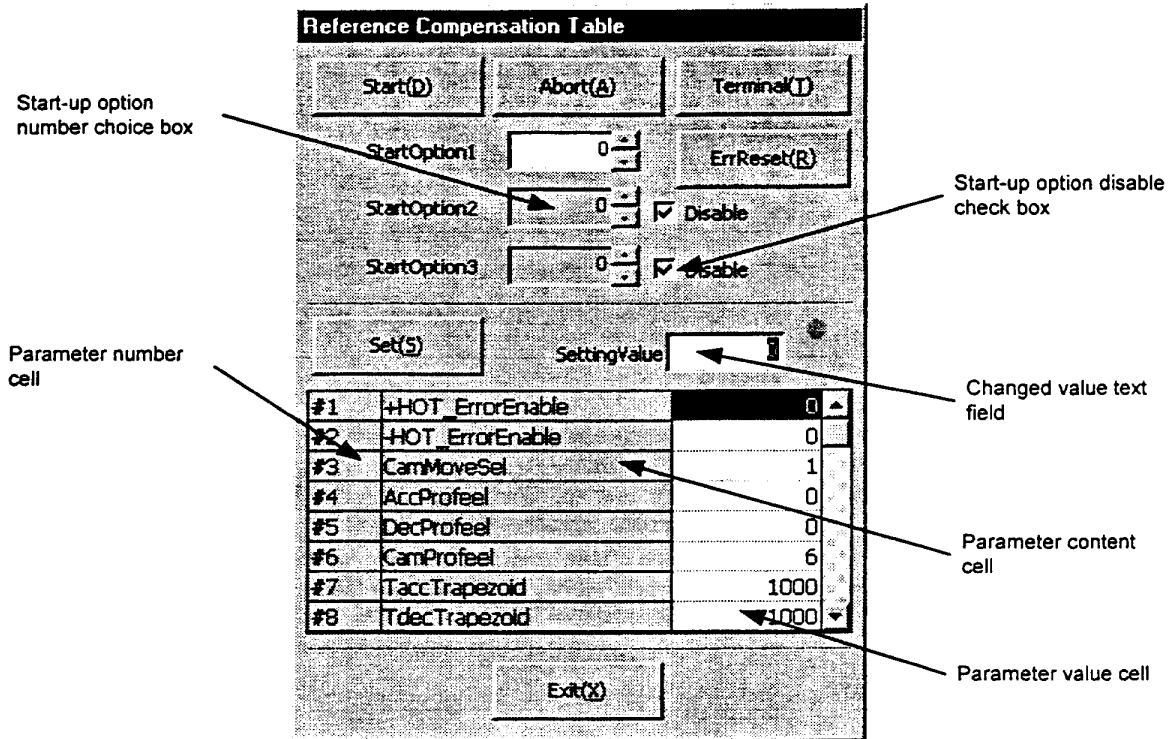

Figure 7.25 "Reference Compensation Table" dialog box

### (1) Editing parameters

- 1) Click the parameter value cell of the parameter to be changed. The current value is displayed in the changed value text field.
- 2) Enter a value in the changed value text field and click the Enter (Return) key or click another cell to make the new parameter value valid.
- 3) Repeat steps 1) and 2) as necessary and click "Set (S)" to set the changed values in the driver. If there is an error in the set value, a warning message is displayed and the parameter is read again. Parameters whose setting values are erroneous will not be changed; therefore the changed parameters should be verified.

## (2) Editing start-up options

- 1) Select the number in the start-up option number choice box for the start-up option to be changed. However, it is not possible to edit when the start-up option disable check box is set to disabled.
- 2) If start-up options are not necessary, the start-up option disable check box should be clicked to disable the start-up option number choice box. In this case, the disabled start-up options will not be set.

## (3) Operation

Operation of the motor is possible when the main operation mode is set to the RS232C main operation mode (see Chapter 5). (In the PLC main operation mode, several buttons are disabled.)

### [Start]

- 1) Set the motor to Servo ON (see Chapter 5).
- 2) Click "*Start (D).*"

### [Abort]

- 1) Click "*Abort (A).*"  
→ The motor decelerates and stops.

### [Error Reset]

- 1) Click "*ErrReset (R).*"  
→ Errors that can be recovered are canceled.

### [Simplified terminal]

- 1) Click "*Terminal (T).*"
- 2) Send or receive character strings.

## 7.5.6 Jog Move

Click "Jog (J)" in the "DriveMenu" dialog box to display the "JogMove" dialog box (see Figure 7.26). If the connection with the driver is established, the current values of the related parameters are read and can be edited.

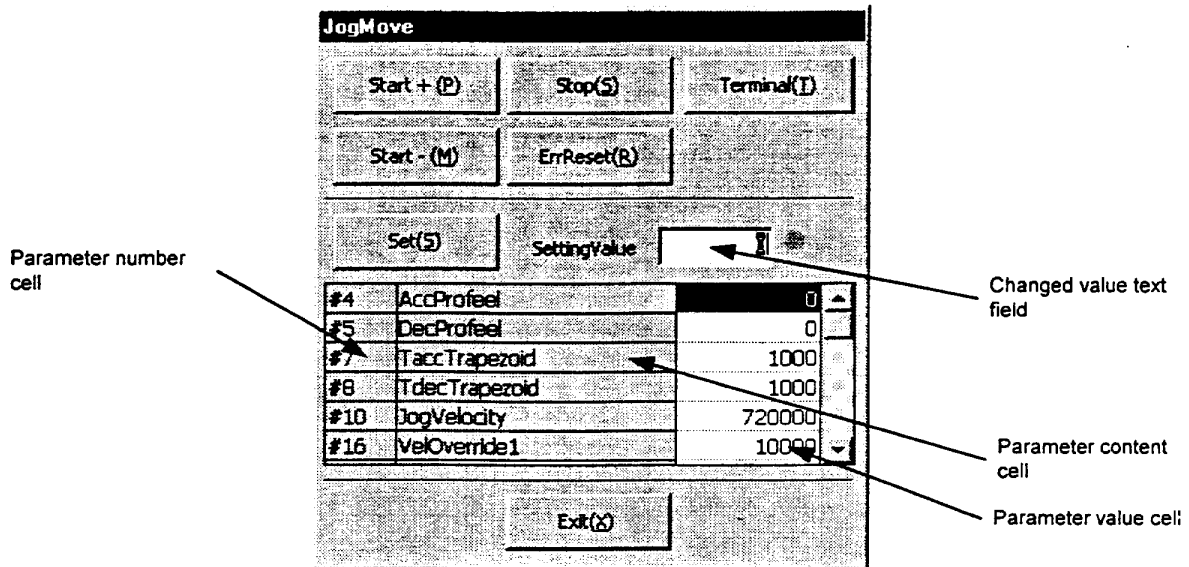

Figure 7.26 "JogMove" dialog box

## (1) Editing parameters

- 1) Click the parameter value cell of the parameter to be changed. The current value is displayed in the changed value text field.
- 2) Enter a value in the changed value text field and click the Enter (Return) key or click another cell to make the new parameter value valid.
- 3) Repeat steps 1) and 2) as necessary and click "Set (S)" to set the changed values in the driver. If there is an error in the set value, a warning message is displayed and the parameter is read again. Parameters whose setting values are erroneous will not be changed; therefore the changed parameters should be verified.

## (2) Operation

The following operation can be performed when jog move is selected via the RS232C interface (see Chapter 5).  
(When the main operation mode is set to the PLC main operation mode, some buttons are disabled.)

### [Jog move in positive direction]

- 1) Set the motor to Servo ON (see Chapter 5).
- 2) Click "Start + (P)."

### [Jog move in negative direction]

- 1) Set the motor to Servo ON (see Chapter 5).
- 2) Click "Start - (M)."

### [Jog stop]

- 1) Click "Stop (S)."

### [Error Reset]

- 1) Click "ErrReset (R)."  
→ Recoverable errors are canceled.

### [Simplified terminal]

- 1) Click "Terminal (T)."
- 2) Send or receive character strings.

## 7.6 Data Management Menus

### 7.6.1 Parameter Manager

This menu allows you to save all the parameters to files and register them from files in addition to edit the machine setting parameters.

Click "*Parameter (M)*" under "MainMenu" to display the "Parameter Manager" dialog box (see Figure 7.27).

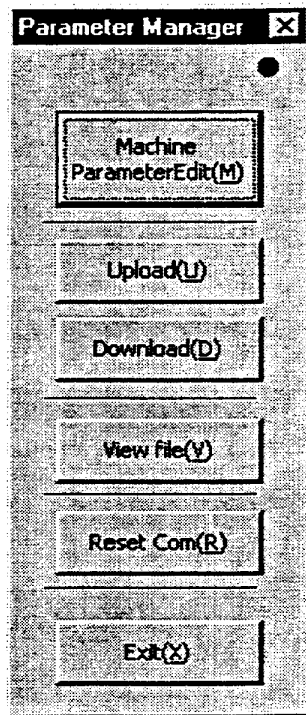

Figure 7.27 "Parameter Manager" dialog box

## (1) Editing machine parameters

Click "*Machine Parameter Edit (M)*" in the "Parameter Manager" dialog box to display the "MachineParameterEdit" dialog box (see Figure 7.28). If the connection with the driver is established, the current values of the machine parameters are read and can be edited.



Figure 7.28 "MachineParameterEdit" dialog box

### [Editing]

- 1) Click the parameter value cell of the parameter to be changed. The current value is displayed in the changed value text field.
  - 2) Enter a value in the changed value text field and click the Enter (Return) key or click another cell to make the new parameter value valid.
  - 3) Repeat steps 1) and 2) as necessary and click "Set (S)" to start downloading to the driver. (If you click "Exit (X)," the parameter values are not changed.)
  - 4) When the downloading is finished, follow the message and reset the driver.
- Note: If any erroneous data are set, the parameters that could not be downloaded are displayed. In this case, reset the driver once and set the parameters again.
- Note: In the case of the machine setting parameters, the changed values cannot be updated until you reset the driver.

## (2) Uploading (from the driver to a file)

- 1) Click "*Upload (U)*" in the "Parameter Manager" dialog box.
- 2) Enter the name of the file to which parameters are to be saved. Do not enter a file extension (\*.prm); it is added automatically.
- 3) Click "*Save (S)*" to start uploading. If you wish to stop the uploading, click "*Cancel.*"



## (3) Downloading (from a file to the driver)

- 1) Click "Download (D)" in the "Parameter Manager" dialog box.
- 2) Enter the name of the file to be downloaded to the driver. Do not enter a file extension (\*.prm); it is added automatically.
- 3) Click "Open (O)" to start downloading. If you wish to stop the downloading, click "Cancel."
- 4) When the downloading is finished, follow the message and reset the driver.

## (4) Displaying the file contents

- 1) Click "View file (V)" in the "Parameter Manager" dialog box.
- 2) Enter the name of the file you want to display. Do not enter a file extension (\*.prm); it is added automatically.
- 3) Click "Open (O)" to begin displaying the file contents in the "Parameter file display" dialog box (see Figure 7.29).
- 4) If you want to print the file, click "Print (P)."
- 5) Click "Exit (X)" and return to the "Parameter Manager" dialog box.

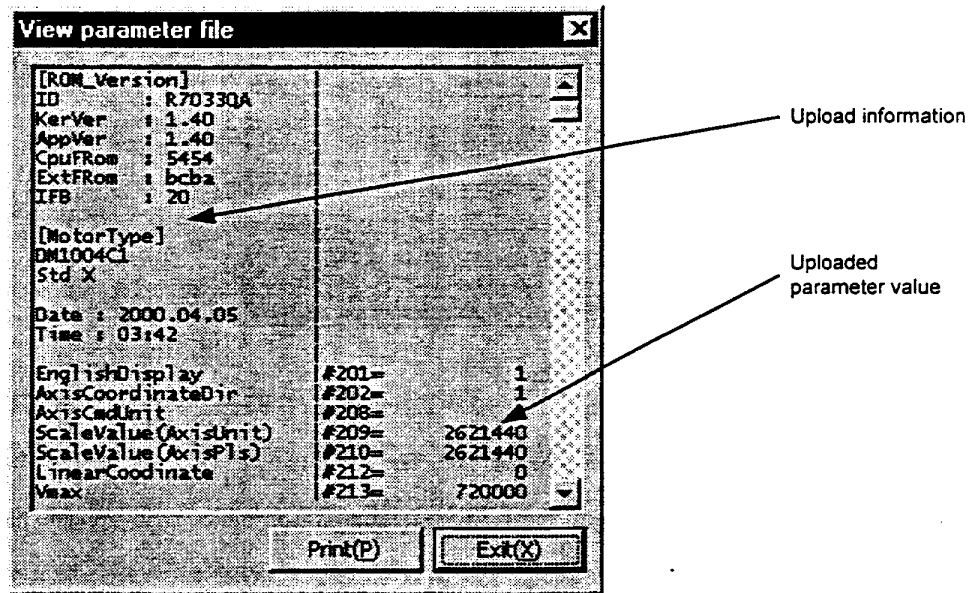

Figure 7.29 "Parameter file display" dialog box

## (5) Resetting the communication

If the communication with the driver finishes abnormally, click "Reset Com (R)" in the "Parameter Manager" dialog box to return to the normal status.

## 7.6.2 Program Manager

This menu allows you to edit, register, and save the programs necessary for program operation. In addition, you can start or stop a program and monitor the program block currently being executed.

Click "*Program (G)*" under "MainMenu" to display the "Program Manager" dialog box (see Figure 7.30).

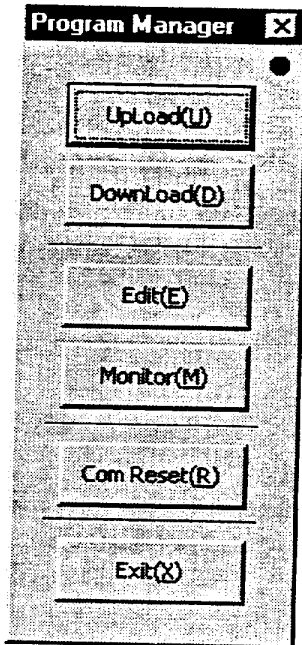

Figure 7.30 "Program Manager" dialog box

### (1) Uploading (from the driver to a file)

Programs can be uploaded by the following two methods:

- "Normal upload": Upload a single program.
- "Upload all": Upload all the user programs registered in the driver.

Click "*Upload (U)*" in the "Program Manager" menu to display the "Select type" dialog box (see Figure 7.31).

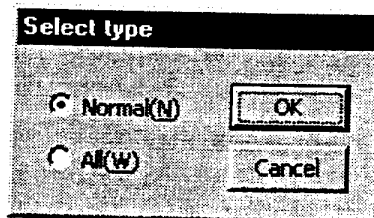

Figure 7.31 "Select type" dialog box

## [Normal upload]

- 1) Click "*Normal (N)*" in the "Select type" dialog box.
- 2) The "Properties" dialog box is displayed where you can enter a program number. Enter a program number between 0 and 89 (user programs). (90 to 99 are system programs.)
- 3) Enter the name of the file in which the program is to be saved. Do not enter a file extension (\*.prg); it is added automatically.
- 4) Click "*Save (S)*" to start uploading. If you wish to stop uploading, click "*Cancel.*"

## [Upload all]

- 1) Click "*All (W)*" in the "Select type" dialog box.
- 2) Enter the name of the file in which the programs are to be saved. Do not enter a file extension (\*.whp); it is added automatically.
- 3) Click "*Save (S)*" to start uploading. If you wish to stop uploading, click "*Cancel.*"

Note: When you use the upload all method, a batch program file is created together with each program (file extension .prg). A program number registered in the batch program file name is attached to each program file name.

## (2) Downloading (from a file to the driver)

Programs can be downloaded by the following two methods:

- "Normal download": Download a single program.
- "Download all": Download all the user programs saved in the batch download file.

Click "*Download (D)*" in the "Program Manager" menu to display the "Select type" dialog box (see Figure 7.32).

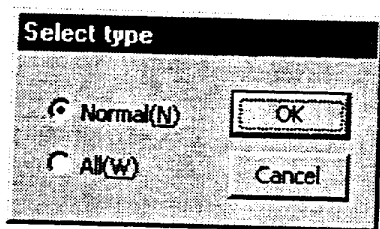

Figure 7.32 "Select type" dialog box

## [Normal download]

- 1) Click "*Normal (N)*" in the "Select type" dialog box.
- 2) The "Properties" dialog box is displayed where you can enter a program number. Enter a program number between 0 and 89 (user programs). (90 to 99 are system programs.)
- 3) Enter the name of the file to be downloaded. Do not enter a file extension (\*.prg); it is added automatically.
- 4) Click "*Open (O)*" to start downloading. If you wish to stop downloading, click "*Cancel.*"

[Download all]

- 1) Click "All (W)" in the "Select type" dialog box.
- 2) Enter the name of the batch file to be downloaded. Do not enter a file extension (\*.whp); it is added automatically.
- 3) Click "Open (O)" to start downloading. If you wish to stop downloading, click "Cancel."

### (3) Editing programs

Via the Program Edit menu, you can create new programs and edit programs registered in the driver and files. In addition, edited files can be registered in the driver or saved in a file.

Click "Edit (E)" in the "Program Manager" menu to display the "Program Edit" dialog box (see Figure 7.33).

The editing screen is divided into two windows, an upper and a lower editor window, and either of them may be used for editing. It is effective to use the upper editor window for editing work and load an existing program into the lower editor window to cut and paste only the necessary parts. (Cut and paste can be performed through the basic Windows operations.)

Select the text with the mouse and then cut (Ctrl + X), copy (Ctrl + C), and paste (Ctrl + V).

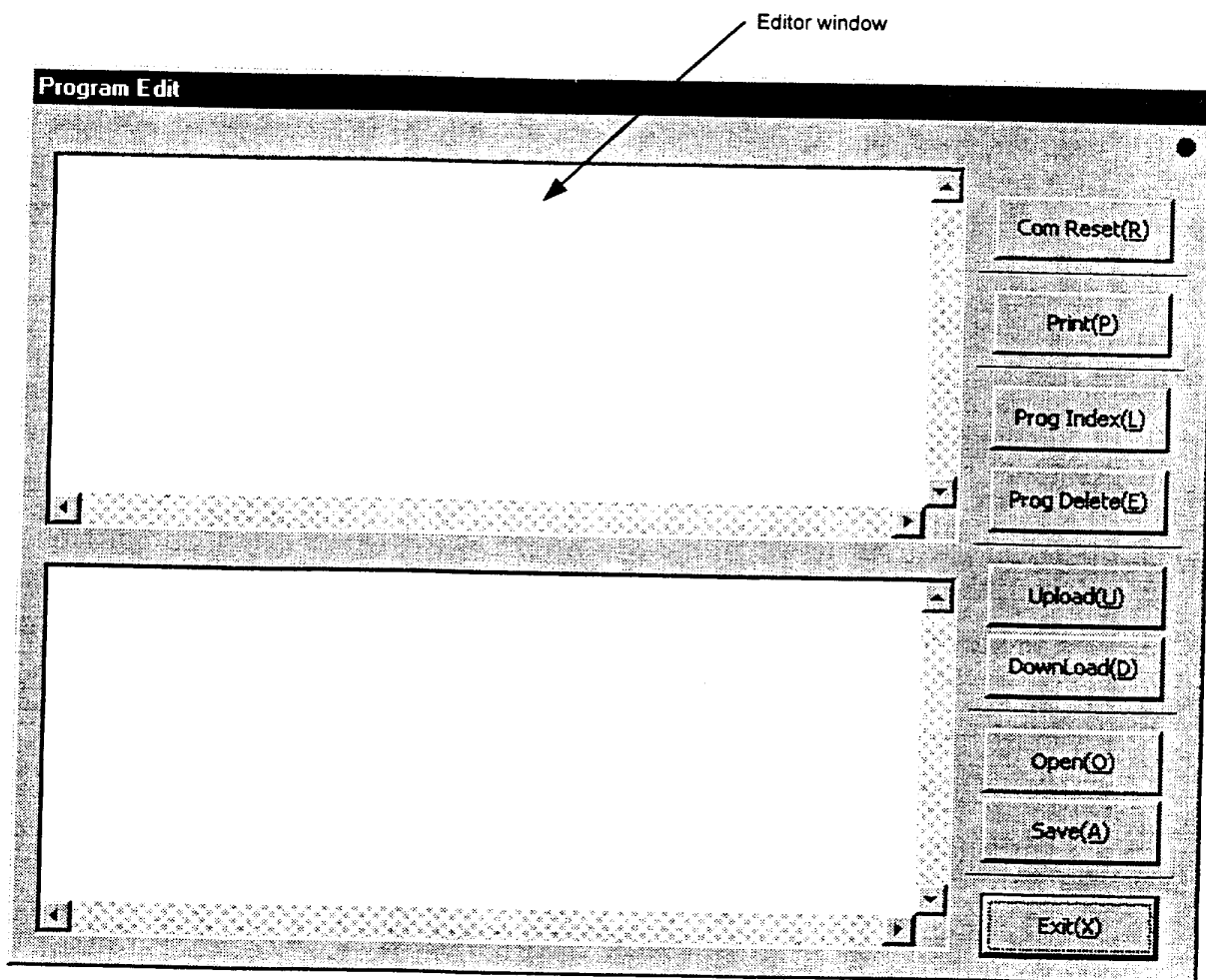

Figure 7.33 "Program Edit" dialog box

**[Creating a new program]**

- 1) Write a program on the upper or lower editor window following the program syntax (see Chapter 5).

**[Editing a program registered in the driver]**

- 1) Click "*Upload (U)*" in the "Program Edit" dialog box.
- 2) The "Properties" dialog box is displayed. In the "Editor window," select the window (upper/lower) in which to display the program and enter the program number.
- 3) Click "*OK*." The program is read from the driver and displayed in the editor window.
- 4) Edit or add to the program as necessary, following the program syntax (see Chapter 5).

**[Editing a program saved in a file]**

- 1) Click "*Open (O)*" in the "Program Edit" dialog box.
- 2) The "Properties" dialog box is displayed. In the "Editor window," select the window (upper/lower) in which to display the program and click "*OK*."
- 3) Enter the program file name in "File name" in the "Open file" dialog box, then click "*Open (O)*." The program is read from the file and displayed in the editor window.
- 4) Edit or add to the program as necessary, following the program syntax (see Chapter 5).

**[Registering a program in the driver]**

- 1) Click "*Download (D)*" in the "Program Edit" dialog box.
- 2) The "Properties" dialog box is displayed. In the "Editor window," select the window (upper/lower) in which the file you want to register is displayed and enter the program number to which the program is to be registered, then select any necessary registration options (see below) and click "*OK*."

**[Registration option]****Required for Servo ON:**

At program execution, the Servo ON status of the driver is checked. If the Servo is not in ON status, none of the program lines are executed and an error occurs. (If you do not check this option, the program is executed until it reaches a line that operates the motor, then if the motor is not in the Servo ON status at this point, an error occurs.)

**Required for operation coordinate settling:**

At program execution, the operation coordinate settling status is checked. If the operation coordinate system is not settled, none of the program lines are executed and an error occurs. (If you do not check this option, the program is executed until it reaches a line that makes the motor move incrementally, then if the operation coordinate system is not settled at this point, an error occurs.)

- 3) When a program error occurs, the registration stops and lines with errors are displayed in red.

**[Saving a program in a file]**

- 1) Click "*Save (A)*" in the "Program Edit" dialog box.
- 2) The "Properties" dialog box is displayed. In the "Editor window," select the window (upper/lower) in which the file you want to save is displayed and enter the program number to which the program is to be registered, then select any necessary registration options (see above) and click "*OK*."
- 3) Enter the program file name and click "*Save (S)*." Do not enter a file extension (\*.prg); it is added automatically.

[Deleting a program]

- 1) Click "*Prog Delete (E)*" in the "Program Edit" dialog box.
- 2) The "Properties" dialog box is displayed. Enter the number of the program to be deleted and click "OK."

[Index of programs]

- 1) Click "*Prog Index (L)*" in the "Program Edit" dialog box. The program numbers registered in the driver are displayed along with the numbers of blocks used and the number of blocks remaining.

[Printing a program]

- 1) Click "*Print (P)*" in the "Program Edit" dialog box.
- 2) The "Properties" dialog box is displayed. In the "Editor window," select the window in which the file you want to print is displayed and click "OK."

[Resetting the communication]

- 1) If the communication with the driver was terminated abnormally, click "*Reset Com (R)*" in the "Program Edit" dialog box to return to the normal status.

## 7 DrvMII PC Utility

### (4) Program monitor

This menu allows you to monitor the program number and block number currently being executed. In addition, if you set the main operation mode to the RS232C main operation mode (see Chapter 5), programs can be started up.

Click *"Monitor (M)"* in the "Program Manager" dialog box to display the "Program Monitor Init" dialog box (see Figure 7.34).

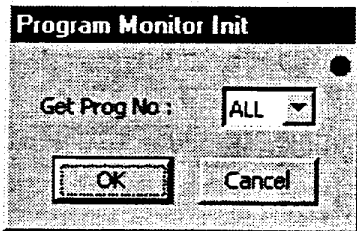

Figure 7.34 "Program Monitor Init" dialog box

In the "Program Monitor Init" dialog box, you can select the program number whose program contents you wish to acquire. If you select [All], the contents of all the programs registered to the driver are obtained. The contents of programs not acquired cannot be displayed at monitoring. Click *"OK"* to start acquiring the contents of the programs. Click *"Cancel"* to return to the "Program Manager" dialog box.

When the acquisition of the program contents is finished, the "Program Monitor" dialog box is displayed and the "Setting Option" dialog box is displayed on top of it (see Figure 7.35).

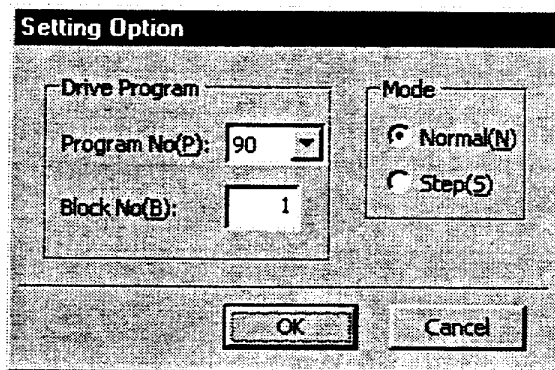

Figure 7.35 "Setting Option" dialog box

[Setting an option]

- 1) Enter the numbers of the program and block to be executed.
- 2) Select the operation mode (if you select step execution, the program stops after each execution of a block).
- 3) Click "OK" to make the setting status valid and return to the "Program Monitor" dialog box. If you click "Cancel," the PC utility returns to the "Program Monitor" dialog box without making the setting status valid (see Figure 7.36).

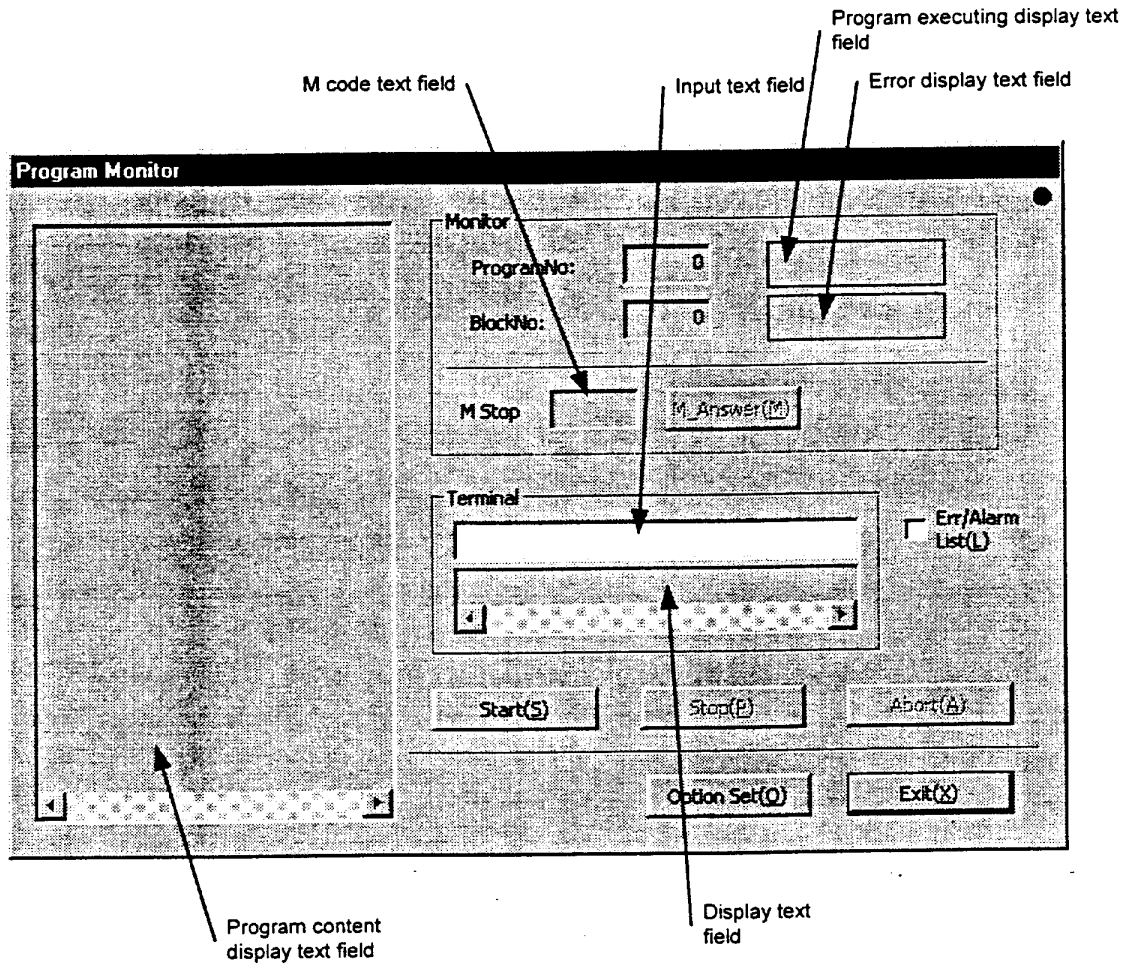

Figure 7.36 "Program Monitor" dialog box.

[Starting a program]

- 1) When you click "Start (S)," the message "Program being executed" is displayed in the "Monitor" box. During the execution of a program, the program number and block number are displayed and, in the program content display text field, the block that is being executed is displayed in yellow.



**[Stopping a program]**

- 1) Click "*Stop (P)*" during execution of a program to finish the execution of the current block and stop the program. If you click "*Abort (A)*," the program that is being executed is immediately terminated.

**[Simplified terminal]**

- 1) Enter a character string in the input text field and press the Enter (Return) key to send the character string to the driver.
- 2) The character string is displayed in the display text field when it is received from the driver.

**[M answer]**

- 1) If serial communication is selected for the M function interface, click "*M Answer (M)*" to send an M answer in response to the M code output in a program.

**[Processing at error/alarm occurrence]**

- 1) If an error occurs, "Error" is displayed in the error display text field. Click "*Error or Alarm (L)*" to display the "Error or Alarm" dialog box (see Figure 7.37). To reset an error status, click "*ErrReset (R)*."

Note: If you leave the "Error or Alarm" dialog box displayed, errors and alarms are not updated. Close the "Error or Alarm" dialog box once and display it again. Or, click "*Update (F)*."

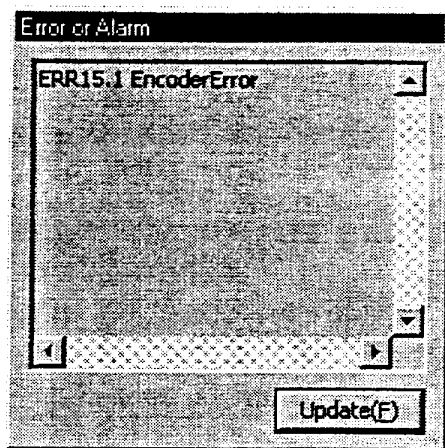

Figure 7.37 "Error or Alarm" dialog box

### 7.6.3 Index Menu

This menu allows you to edit, register, and save data necessary for “index Type A operation (equal division compensation)” and “index Type B operation (unequal division compensation).”

Click “*Index Comp (N)*” under “MainMenu” to display the “Index Menu” dialog box (Figure 7.38).

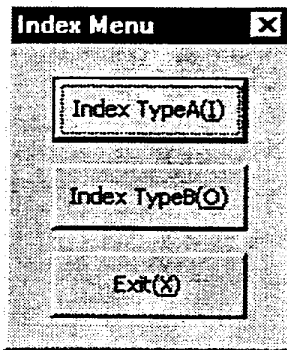

Figure 7.38 “Index Menu” dialog box

#### (1) Equal division compensation

Click “*IndexTypeA (I)*” on “Index Menu” to display the “Index compensation” dialog box (see Figure 7.39).

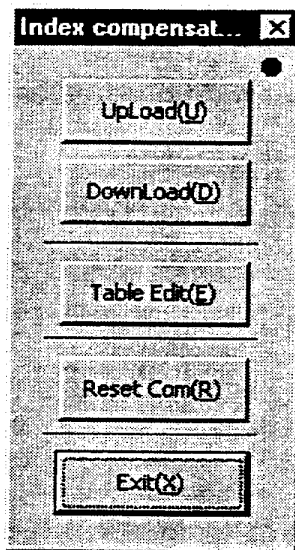

Figure 7.39 “Index compensation” dialog box

## (2) Uploading (from the driver to a file)

Index compensation data can be uploaded by the following two methods:

- “Normal upload”: Upload single index compensation data.
- “Upload all”: Upload all the index compensation data registered in the driver.

Click “*Upload (U)*” in the “Index Comp” menu to display the “Select type” dialog box (see Figure 7.40).

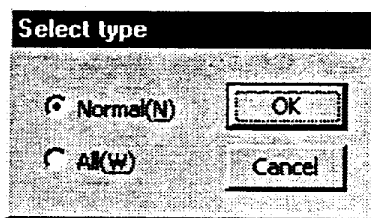

Figure 7.40 “Select type” dialog box

[Normal upload]

- 1) In the “Select type” dialog box, click “Normal (N)” and then “OK.”
- 2) Select the file to upload using the ↓ and click “OK.”  
Two types of index compensation files (files A and B) are available for the driver.
- 3) Enter the name of the file in which to save the compensation file. Do not enter a file extension (\*.idx); it is added automatically.
- 4) Click “Save (S)” to start uploading. If you wish to stop uploading, click “Cancel.”

[Upload all]

- 1) In the “Select type” dialog box, click “All (W)” and then “OK.”
- 2) Enter the name of the batch index compensation file. Do not enter a file extension (\*.whi); it is added automatically.
- 3) Click “Save (S)” to start uploading. If you wish to stop uploading, click “Cancel.”

Note: When you use the upload all method, a batch index compensation file is created together with each index compensation file (file extension .idx). A file number registered in the batch index compensation file name is attached to each index compensation file name.

(3) Downloading (from a file to the driver)

Index compensation data can be uploaded by the following two methods:

- “Normal download”: Download single index compensation data.
- “Download all”: Download all the index compensation data registered in the driver.

Click “Download (D)” in the “Index Comp” menu to display the “Select type” dialog box (see Figure 7.41).

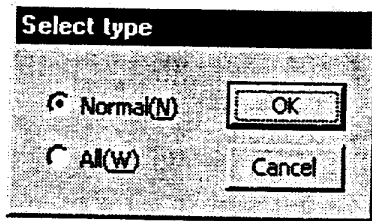

Figure 7.41 “Select type” dialog box

[Normal download]

- 1) Click “Normal (N)” in the “Select type” dialog box.
- 2) Select a file download using the ↓ and click “OK.”  
Two types of index compensation file (files A and B) are available for the driver.
- 3) Enter the name of the file to register to the driver. Do not enter a file extension (\*.idx); it is added automatically.
- 4) Click “Open (O)” to start downloading. If you wish to stop downloading, click “Cancel.”

[Download all]

- 1) In the “Select type” dialog box, click “All (W)” and then “OK.”
- 2) Enter the batch index compensation file name to register to the driver. Do not enter a file extension (\*.whi); it is added automatically.
- 3) Click “Open (O)” to start downloading. If you wish to stop downloading, click “Cancel.”

## (4) Editing unequal division compensation data

You can edit compensation files registered in the driver or saved in files.

Click "Table Edit (E)" in the "Index compensation" dialog box to display the "Index Compensation Table" dialog box (see Figure 7.42).

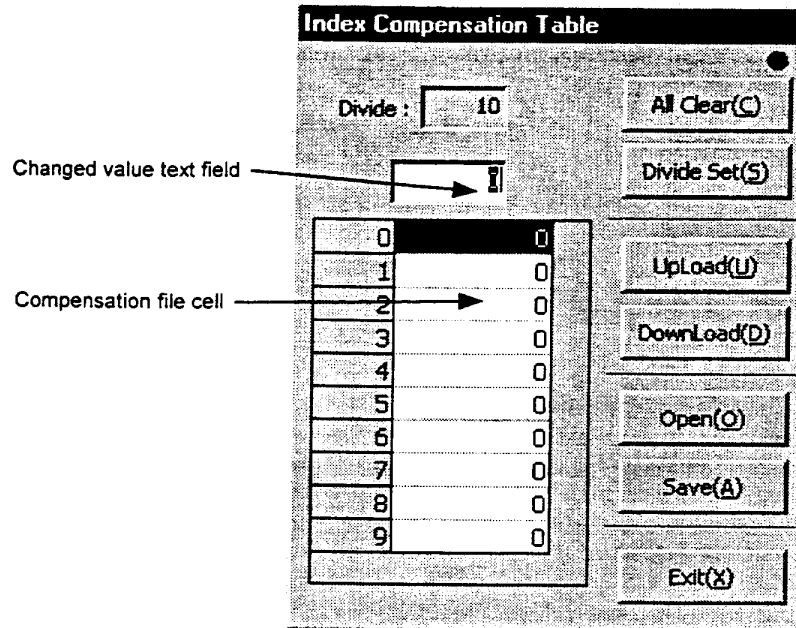

Figure 7.42 "Index Compensation Table" dialog box

[Creating a new compensation file]

- 1) Click "Divide Set (S)" and set the number of divisions.
- 2) Click the compensation file cell to be changed in order to display the current value in the changed value text field.
- 3) Enter a value in the changed value text field, then press the Enter (Return) key or click another compensation file cell. The value of the compensation file cell you want to change will then be updated.
- 4) Repeat steps 1) and 2) as necessary.

[Registering a compensation file (from the edit screen to the driver)]

- 1) Click "Download (D)" to display the "Select compensation file" dialog box.
- 2) Select the file number and click "OK."

[Saving a compensation file (from the edit screen to a file)]

- 1) Click "Save (A)," enter a file name, and click "Save (S)." (Do not enter a file extension (\*.idx); it is added automatically.)

[Displaying a compensation file (from the driver to the edit screen)]

- 1) Click "*Upload (U)*" to display the "Select compensation file" dialog box.
- 2) Select the file number and click "*OK.*"

[Displaying a compensation file (from a file to the edit screen)]

- 1) Click "*Open (O)*," enter the file name, and click "*Open (O)*." (Do not enter a file extension (\*.idx); it is added automatically.)

[Clearing all]

- 1) Click "*Clear All (C)*" to clear all the values of the compensation file cell array to 0.

(5) Resetting communication

If the communication with the driver finishes abnormally, click "*Reset Com (R)*" in the "Index compensation" dialog box to return to the normal status.

(6) Unequal division

Click "Index TypeB (O)" in the "Index compensation" dialog box to display the "Index TypeB Menu" dialog box (see Figure 7.43).

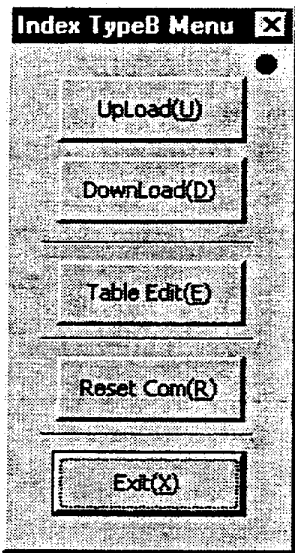

Figure 7.43 "Index TypeB Menu" dialog box

(7) Uploading (from the driver to a file)

Index type B data can be uploaded by the following two methods:

- "Normal upload": Upload single index type B data.
- "Upload all": Upload all the index type B data registered in the driver.

[Normal upload]

Click "Upload (U)" in the "Index TypeB Menu" to display the "Select type" dialog box (see Figure 7.44).

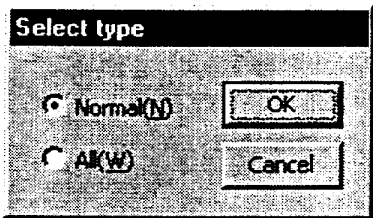

Figure 7.44 "Select type" dialog box

- 1) In the "Select type" dialog box, click "Normal (N)" and then "OK."
- 2) Select the file to upload using the ↓ and click "OK."  
Two types of index type B files (files A and B) are available for the driver.
- 3) Enter the name of the file in which to save the index type B file. Do not enter a file extension (\*.idp); it is added automatically.
- 4) Click "Save (S)" to start uploading. If you wish to stop uploading, click "Cancel."

[Upload all]

- 1) In the "Select type" dialog box, click "All (W)" and then "OK."
  - 2) Enter the name of the batch index type B file. Do not enter a file extension (\*.whp); it is added automatically.
  - 3) Click "Save (S)" to start uploading. If you wish to stop uploading, click "Cancel."
- Note: When you use the upload all method, a batch index type B file is created together with each index type B file (file extension .idp). A file number registered in the batch index type B file name is attached to each index type B file name.

(8) Downloading (from a file to the driver)

Index type B data can be uploaded by the following two methods:

- "Normal download": Download single index type B data.
- "Download all": Download all the index type B data registered in the driver.

Click "Download (D)" in the "Index TypeB Menu" to display the "Select type" dialog box (see Figure 7.45).

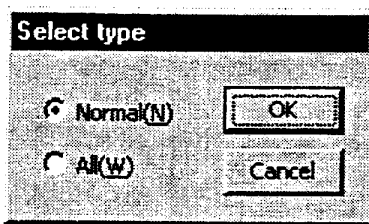

Figure 7.45 "Select type" dialog box

[Normal download]

- 1) In the "Select type" dialog box, click "Normal (N)" and then "OK."
  - 2) Select a file download using the ↓ and click "OK."
- Two types of index type B file (files A and B) are available for the driver.
- 3) Enter the name of the file to register to the driver. Do not enter a file extension (\*.idp); it is added automatically.
  - 4) Click "Open (O)" to start downloading. If you wish to stop downloading, click "Cancel."

[Download all]

- 1) In the "Select type" dialog box, click "All (W)" and then "OK."
- 2) Enter the batch index type B file name to register to the driver. Do not enter a file extension (\*.whp); it is added automatically.
- 3) Click "Open (O)" to start downloading. If you wish to stop downloading, click "Cancel."



## (9) Editing unequal division data

You can edit type B files registered in the driver or saved in files.

Click "Table Edit (E)" in the "Index Type B" dialog box to display the "Index TypeB Compensation Table" dialog box (see Figure 7.46).

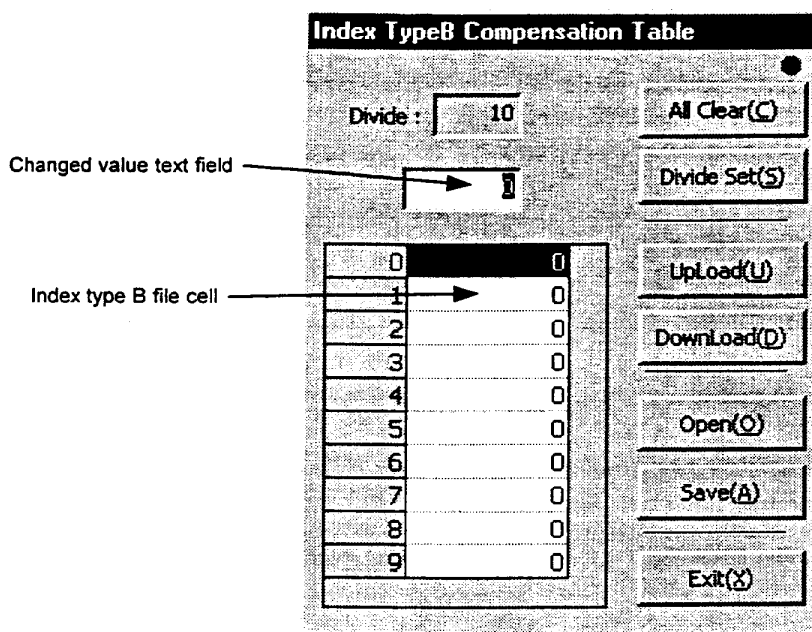

Figure 7.46 "Index TypeB Compensation Table" dialog box

[Creating a new compensation file]

- 1) Click "Divide Set (S)" and set the number of divisions.
- 2) Click the index type B file cell to be changed in order to display the current value in the changed value text field.
- 3) Enter a value in the changed value text field, then press the Enter (Return) key or click another index type B file cell. The value of the index type B file cell you want to change will then be updated.
- 4) Repeat steps 1) and 2) as necessary.

[Registering an index type B file (from the edit screen to the driver)]

- 1) Click "Download (D)" to display the "Select index typeB file" dialog box.
- 2) Select the file number and click "OK."

[Saving an index type B file (from the edit screen to a file)]

- 1) Click "Save (A)," enter a file name, and click "Save (S)." (Do not enter a file extension (\*.idp); it is added automatically.)

[Displaying an index type B file (from the driver to the edit screen)]

- 1) Click "*Upload (U)*" to display the "Select index typeB file" dialog box.
- 2) Select the file number and click "*OK.*"

[Displaying an index type B file (from a file to the edit screen)]

- 1) Click "*Open (O)*," enter the file name, and click "*Open (O)*." (Do not enter a file extension (\*.idp); it is added automatically.)

[Clearing all]

- 1) Click "*Clear All (C)*" to clear all the values of the index type B file cell array to 0.

#### (10) Resetting the communication

If the communication with the driver finishes abnormally, click "*Reset Com (R)*" in the "Index TypeB Menu" to return to the normal status.

## 7.6.4 Point Set

This menu allows you to edit, and register data necessary for table reference operation.

Click "Point Set (P)" under "MainMenu" to display the "Point Set" dialog box (see Figure 7.47.)"

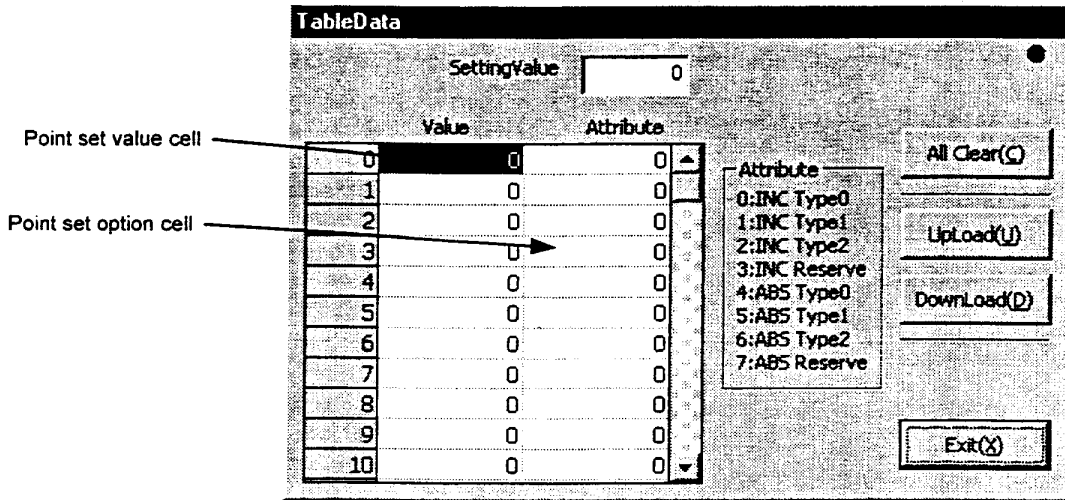

Figure 7.47 "Point Set" dialog box

### (1) Editing points set

- 1) Click the value cell you want to set in order to display the current value in the changed value text field.
- 2) Enter a value in the value cell, then press the Enter (Return) key or click another value cell or option cell. The value of the value cell you want to change will then be updated.
- 3) Click the option cell you want to set in order to display the current value in the changed value text field.
- 4) Enter a value in the option cell, then press the Enter (Return) key or click another option cell or value cell. The value of the option cell you want to change will then be updated.
- 5) Repeat steps 1) to 4) as necessary.

### (2) Displaying points set (from the driver to the edit screen)

- 1) Click "Upload (U)" in the "Point Set" dialog box to display the setting values on the edit screen.

### (3) Registering points set (from the edit screen to the driver)

- 1) Click "Download (D)" in the "Point Set" dialog box to register the setting values displayed on the edit screen to the driver.

Note: Point set values (#600 to 699) and point set options (#700 to 799) are treated as parameters; they are called from the driver to the screen by "Upload" and registered from the screen to the driver by "Download."

## 7.6.5 Parts

This menu allows you to edit (universal cam), register, and save parts necessary for cam profile moves.

Click "*Parts (C)*" under "MainMenu" to display the "Cam Profile Menu" dialog box (see Figure 7.48).

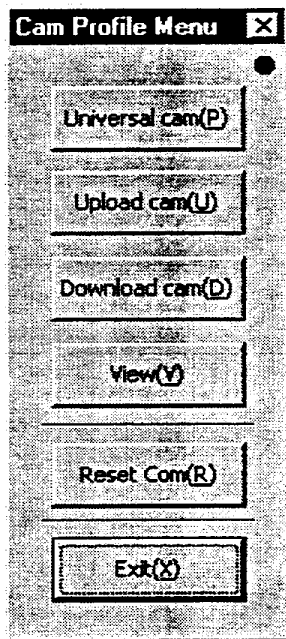

Figure 7.48 "Cam Profile Menu" dialog box

### (1) Creating a universal cam

Click "*Universal cam (P)*" in the "Cam Profile Menu" dialog box to display the Universal cam profile dialog box (see Figure 7.49).

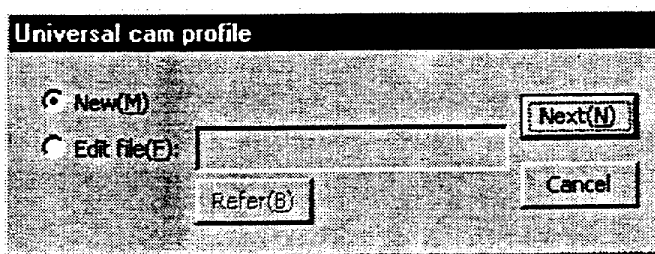

Figure 7.49 "Universal cam profile" dialog box

## 7 DvMII PC Utility

[Creating a new cam profile]

- 1) Select "New (M)" in the "Universal cam profile" dialog box and click "Next (N)" to display the next "Universal cam profile" dialog box.

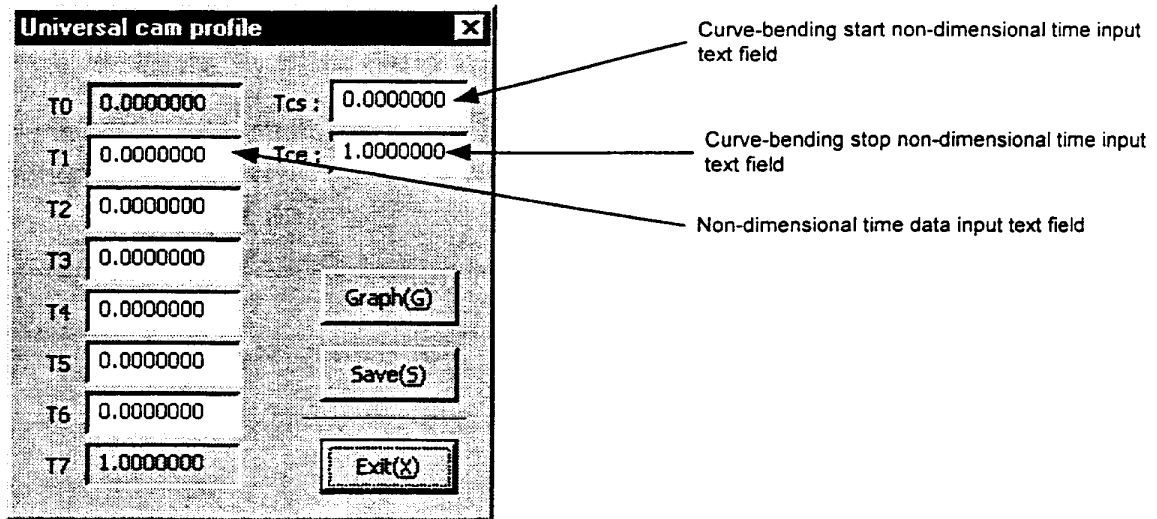

Figure 7.50 "Universal cam profile" dialog box

- 2) Enter data in the non-dimensional time data input text fields "T1" to "T6." The data should be in the range from 0 to 1. Press the Enter (Return) key to make the entry valid.

Note: When you enter data in "T1" to "T6," you cannot enter a value smaller than the data already entered in the items above the one in which you are entering data ("T0" to "T3" if you are entering data in "T4," for instance). Moreover, if the data you enter is larger than the data in items below the current entry ("T5" and "T6" if you are making an entry in "T4," for instance), the data below is limited to this value.

- 3) If you want to bend only the necessary part of a universal cam profile, enter the curve-bending start non-dimensional time (Tcs) and curve-bending stop non-dimensional time (Tce) in the range from 0 to 1. Press the Enter (Return) key to make the entry valid. If you do not intend to bend the curve, enter 0 for Tcs and 1 for Tce.
- 4) Click "Graph (G)" in the "Universal cam profile" dialog box to display the graph of a universal cam profile (see figure 7.51).

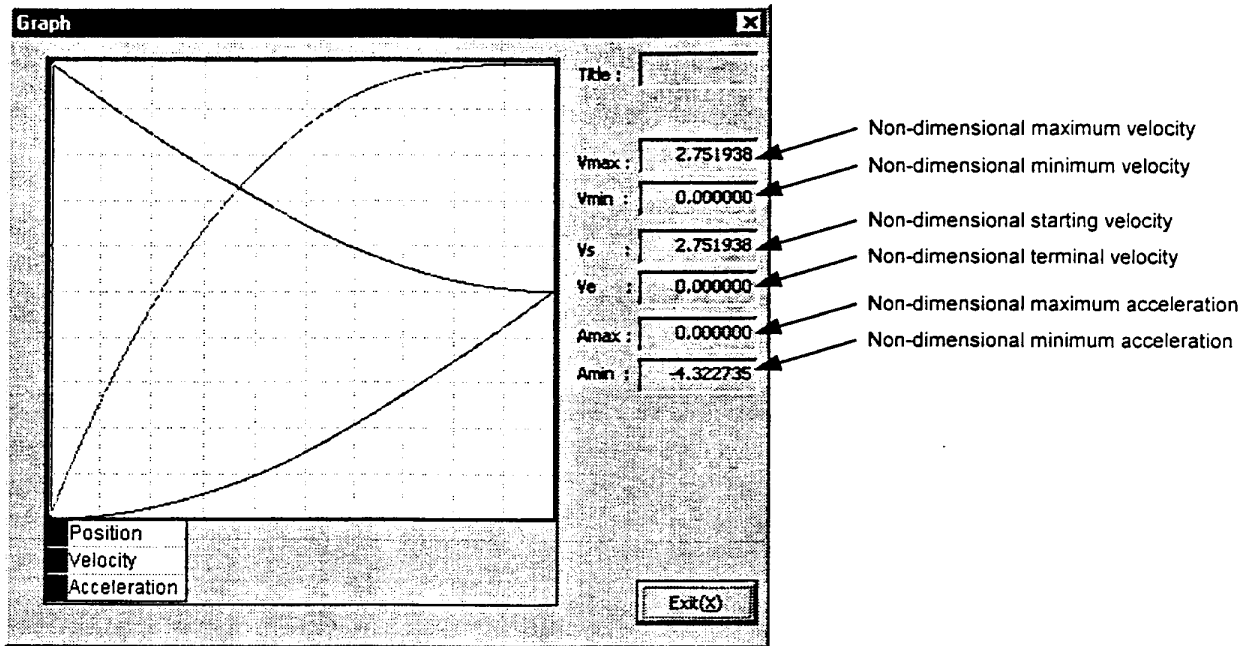

Figure 7.51 "Universal cam profile" graph

- Along the horizontal axis, the far left is non-dimensional time 0 and the far right is non-dimensional time 1.
- Along the vertical axis, the bottom is non-dimensional position 0 and the top is non-dimensional position 1. Also along the vertical axis, the center is non-dimensional velocity and acceleration 0, the top is maximum non-dimensional velocity and acceleration, and the bottom is minimum non-dimensional velocity and acceleration.

[Saving a universal cam profile to a file]

- 1) Click "Save (S)" in the "Universal cam profile" dialog box.
- 2) Enter the name of the file to which the universal cam profile is saved. Do not enter a file extension (\*.unv); it is added automatically.
- 3) Click "Save (S)" to save to the file. If you wish to abort, click "Cancel."

Note: When you save a universal cam profile to a file, a cam profile data file with the same file name (extension .cdt) is also created.

[Saving to a file and closing "Universal cam profile"]

- 1) Click "Exit (X)" in the "Universal cam profile" dialog box.
- 2) A message box is displayed which asks whether or not to save to a file. If you want to save, click "Yes (Y)." The procedure for saving is the same as for [Saving a universal cam profile to a file].
- 3) If you want to exit without saving, click "No (N)" and if you want to return to the "Universal cam profile," click "Cancel."

## [Modifying an existing universal cam profile file]

- 1) Select *"Edit file"* in the "Universal cam profile" dialog box shown in Figure 7.49.
- 2) Enter the file name of a universal cam profile (extension .unv) in the file name input text field. If you are not sure about the accurate file path and name, click *"Browse (R)."*
- 3) Select a file and click *"Open (O)."*
- 4) Click *"Next (N)"* to return to the "Universal cam profile" dialog box.
- 5) The "Universal cam profile" dialog box appears.  
(The procedure from here is the same as [Creating a new cam profile].)

## (2) Uploading (from the driver to a file)

Parts data can be uploaded by the following two methods:

- "Normal upload": Upload single cam profile data.
- "Upload all": Upload all the cam profile data registered in the driver.

Click *"Upload cam (U)"* in the "Cam Profile Menu" to display the "Select type" dialog box.

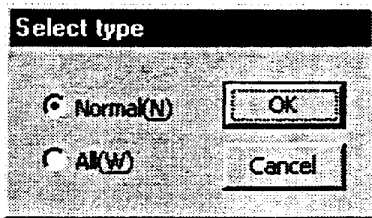

Figure 7.52 "Select type" dialog box

## [Normal upload]

- 1) In the "Select type" dialog box, click *"Normal (N)"* and then *"OK."*
- 2) Enter a cam profile number to upload and click *"OK."*  
Note: Eight standard cam profiles (cam profile numbers 1 to 8) and eight user cam profiles (cam profile numbers 9 to 16) are available for the driver.
- 3) Enter the name of file to which the cam profile is saved. Do not enter file extension (\*.cdt); it is added automatically.
- 4) Click *"Save (S)"* to start uploading. If you wish to stop uploading, click *"Cancel."*

## [Upload all]

- 1) In the "Select type" dialog box, click *"All (N)"* and then *"OK."*
- 2) Enter a batch cam profile data file name. Do not enter a file extension (\*.whc); it is added automatically.
- 3) Click *"Save (S)"* to start uploading. If you wish to stop uploading, click *"Cancel."*  
Note: When you use the upload all method, a batch cam profile data file is created together with each cam profile data file (file extension .cdt). A cam profile numbers registered in the batch cam profile data file is attached to each cam profile data file name.

(3) Downloading (from a file to the driver)

Parts data can be downloaded by the following two methods:

- “Normal download”: Download a single cam profile parts file.
- “Download all”: Download all the cam profile files saved in the batch download file.

Click “*Download cam (D)*” in the “Cam Profile Menu” to display the “Select type” dialog box.

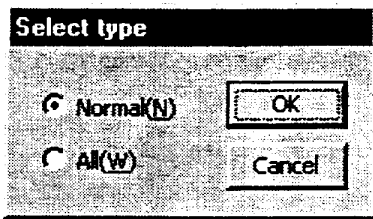

Figure 7.53 “Select type” dialog box

[Normal download]

- 1) Click “*Normal (N)*” in the “Select type” dialog box and click “*OK.*”
  - 2) Enter the download destination cam profile number and click “*OK.*”
- Note: You can download only user cam profiles (cam profile numbers 9 to 16).
- 3) Enter the cam profile file to download. Do not enter a file extension (\*.cdt); it is added automatically.
  - 4) Click “*Open (O)*” to start downloading. If you wish to stop downloading, click “*Cancel.*”

[Download all]

- 1) In the “Select type” dialog box, click “*All (W)*” and then “*OK.*”
- 2) Enter the batch cam profile data file name. Do not enter a file extension (\*.cdt); it is added automatically.
- 3) Click “*Open (O)*” to start downloading. If you wish to stop downloading, click “*Cancel.*”



## (4) Viewing the cam profile

Click "View (V)" in the "Cam Profile Menu" dialog box to display the "View cam profile" dialog box.

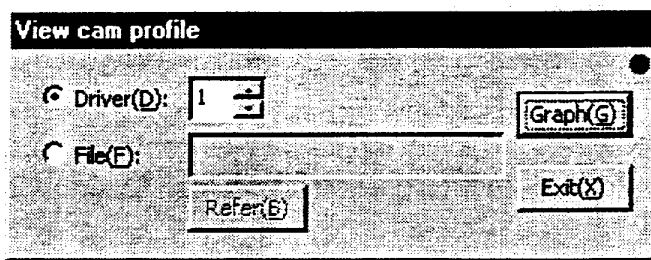

Figure 7.54 "View cam profile" dialog box

[Cam profiles registered in the driver]

- 1) Select "Driver" in the "View cam profile" dialog box.
- 2) Enter the cam profile number to display as a graph.
- 3) Click "Graph (G)" to display the graph of the cam profile.

[Cam profiles saved in a file]

- 1) Select "File" in the "View cam profile" dialog box.
- 2) Enter the cam profile data file name (extension .cdl) in the file name input text field. If you are not sure about the accurate file path and name, click "Browse (R)." Select the cam profile data file you want to display as a graph.
- 3) Click "Open (O)" to return to the "View cam profile" dialog box.
- 4) Click "Graph (G)" to display the graph of the cam profile.

## (5) Resetting the communication

- 1) If the communication with the driver finishes abnormally, click "Reset Com (R)" in the "Cam Profile Menu" to return to the normal status.

## 7.6.6 I/O Set

In this menu, you can set the logical setting of DI/DO points (connector number varies depending on the interface used).

Click "I/O set (I)" under "MainMenu" to display the "I/O configuration" dialog box (see Figure 7.55).

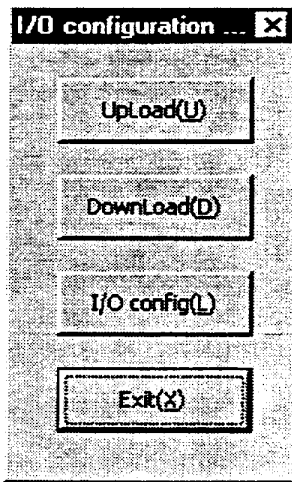

Figure 7.55 "I/O configuration" dialog box

## 7 DrvMII PC Utility

### (1) Logical setting

- 1) Click *"I/O config (L)"* in the "I/O configuration" dialog box.
- 2) The "Discrete configuration" dialog box is displayed and the current setting status is read. (The maximum number of setting statuses that can be displayed at once is 32 points for both DI and DO.)

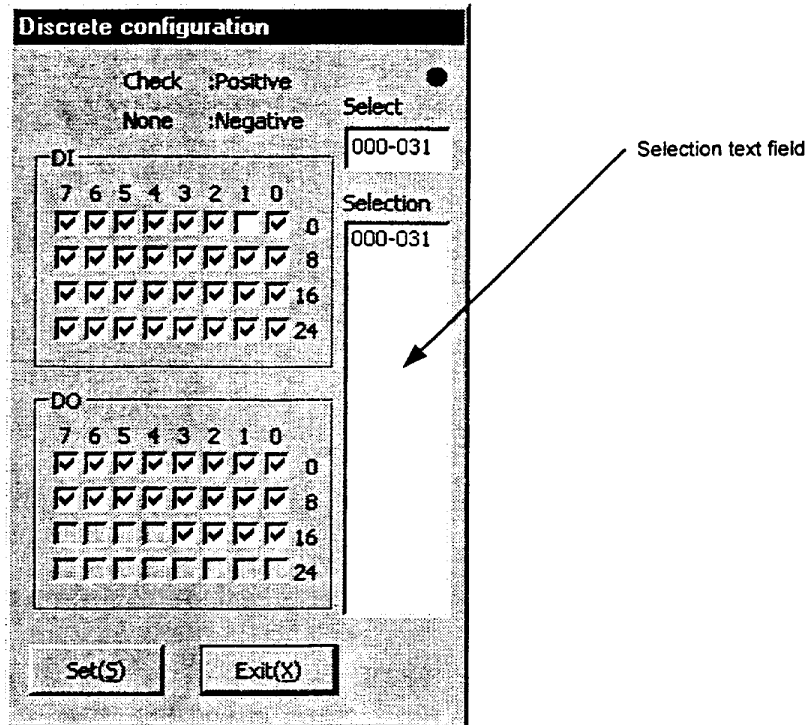

Figure 7.56 "Discrete configuration" dialog box

- 3) Click a number you want to display from the selection text field in order to display the logical setting of that number.
- 4) Click the check boxes of the I/O points to change the logical setting.  
Note: An I/O point with a check mark is set to positive logic (A contact) and an I/O without a check mark is set to negative logic (B contact).
- 5) Click *"Set (S)."*
- 6) When the setting is completed, follow the message and reset the driver.

### (2) Uploading (from the driver to a file)

- 1) Click *"Upload (U)"* in the "I/O configuration" dialog box.
- 2) Enter the name of the file to which I/O configuration is to be saved. Do not enter a file extension (\*.ioc); it is added automatically.
- 3) Click *"Save (S)"* to start uploading. If you wish to stop the uploading, click *"Cancel."*

---

(3) Downloading (from a file to the driver)

- 1) Click "*Download (D)*" in the "I/O configuration" dialog box.
- 2) Enter the name of the file to be downloaded to the driver. Do not enter a file extension (\*.ioc); it is added automatically.
- 3) Click "*Open (O)*" to start downloading. If you wish to stop the downloading, click "*Cancel.*"
- 4) When the downloading is finished, follow the message and reset the driver.



# Chapter 8

## Operation Display Pendant

---

- 8.1 Overview
- 8.2 Features and Part Names
- 8.3 Switching Displays
- 8.4 Terminal Mode Display
- 8.5 Parameter Monitor Display
- 8.6 Parameter Settings Display
- 8.7 I/O Monitor Display
- 8.8 Special Command Display
- 8.9 Program Menu Display
  - 8.9.1 Program Edit Displays
  - 8.9.2 Copying a Program
  - 8.9.3 Deleting a Program

## 8.1 Overview

The operation display pendant (abbreviated as TBX, optional device) should be connected to the CN1 RS232C communication connector. It is set to the same status as the single channel communication in the RS232C interface, regardless of the setting status of the rotary switch RS-ID on the front panel. The following functions are provided for the operation display pendant.

- **Terminal mode display:**  
In this display, you can send @ commands and parameter commands in the same way as with the RS232C interface and display response character strings.
- **Parameter monitor display:**  
In this display the updated contents of parameters/monitors referred to by #\*\*\* can be displayed repeatedly.
- **Parameter settings display:**  
In this display, you can make changes to parameters referred to by #\*\*\*, if they can be written to.
- **I/O monitor display:**  
In this display the updated I/O status of the PLC interface and the signal status of the TB2 sensor/break can be displayed repeatedly.
- **Special command display:**  
In this display, you can issue common commands in a simple manner.
- **Program menu display:**  
In this display, you can edit, copy, and delete programs.

## 8.2 Features and Part Names

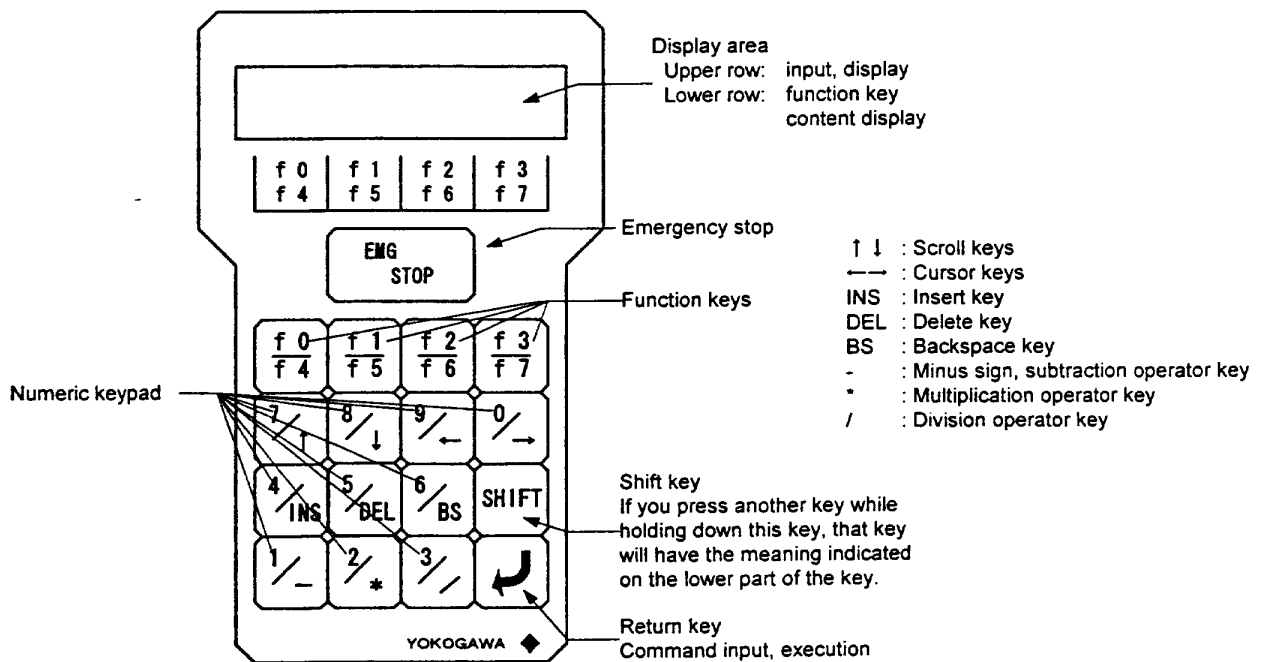

## 8.3 Switching Displays

Each display shifts in the order shown in the figure below. When the power is turned on and the operation display pendant is connected, the initial screen shows the terminal mode display. Each display of the program menu display can be accessed by selecting edit (EDT), copy (CPY), or delete (DEL).

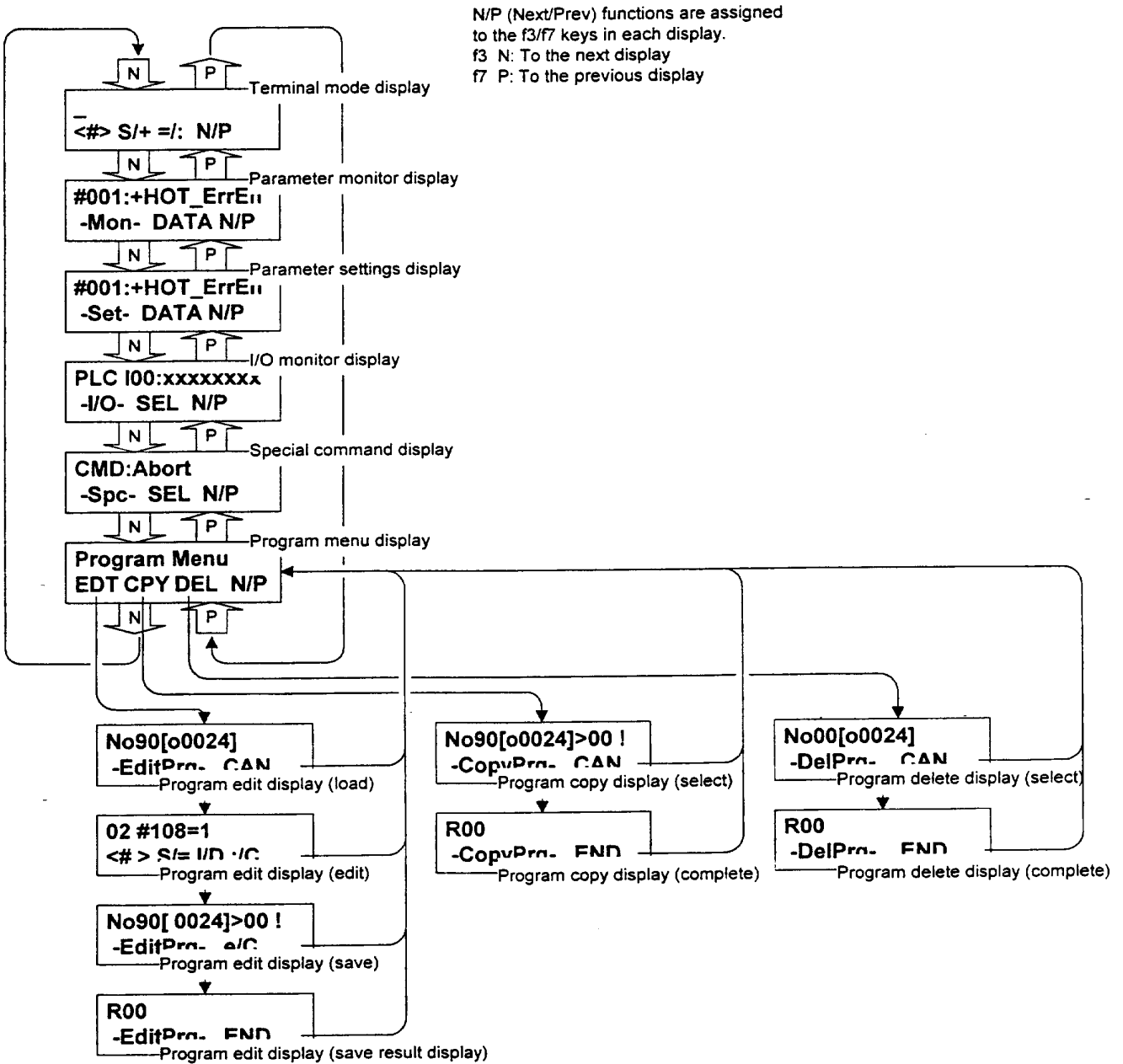



# 8 Operation Display Pendant

## 8.4 Terminal Mode Display

The terminal mode display allows you to send a character string entered from the keypad to the driver and display the response character string in the display.

In the example below, “#50” is input in display 2) and the response character string “R1D position bandwidth:12” is shown in display 3).

In the response character string display, the header part of a response character string (e.g., R00, ALM\*\*, \*) is not displayed. Even though the cursor is not displayed, hidden parts can be horizontally scrolled through and displayed by pressing the ← and → keys.

The cursor is displayed by pressing the input key (a key that allows character input when pressed), or the ↑ and ↓ keys. Once it is displayed, you can enter character strings.

1) Initial display

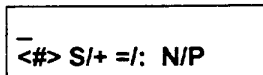

2) During character string input

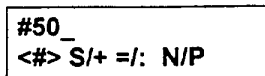

3) Displaying a response character string

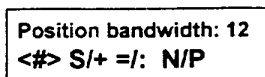

Characters in <>:

#, @, %, G, X,  
F, f, A, a, M, P, +

- f0 <>: Character selection (positive direction)  
The character in <> changes at every key press.
- f1 S: Inputs the selected character.  
The character in <> is input by pressing this key.
- f2 =: Inputs =.
- f3 N: To the next display
- f4 <>: Character selection (opposite direction)  
The character in <> changes at every key press.
- f5 +: Inputs +.
- f6 :.: Inputs :.
- f7 P: To the previous display

0 to 9: Each character is input.  
-, \*, /

INS key: Shifts the character string one character after the cursor position and insert a space at the cursor position.  
DEL key: Deletes the character immediately before the cursor. The cursor does not move the position.

BS key: Deletes the character immediately before the cursor and move the cursor to the position one character before.

Return key: Sends the entered character string to the controller.

← and → keys: Moves the cursor on the input character string to the left or right.

↑ and ↓ keys: Moves up and down in the input character string buffer.

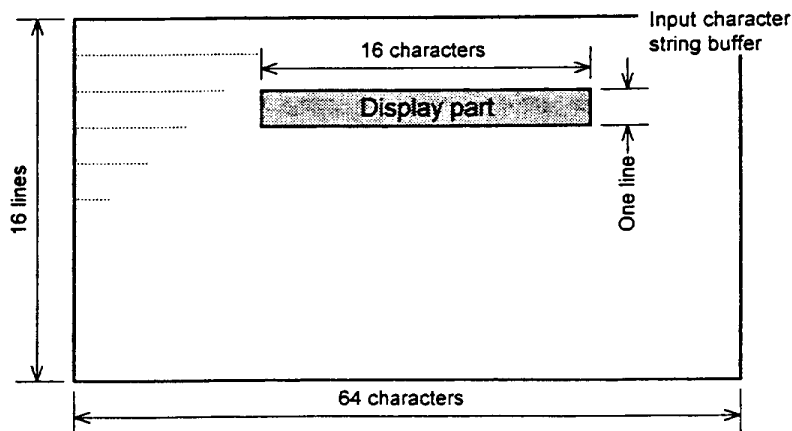
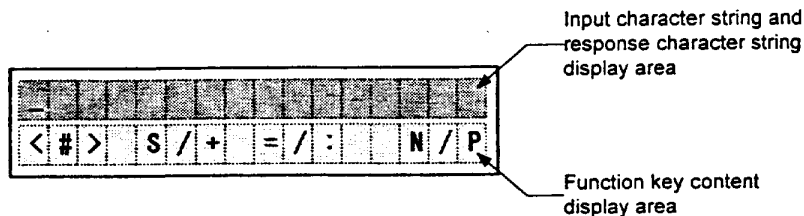

## 8.5 Parameter Monitor Display

The current values of parameters/monitors with the numbers input from the keypad are displayed periodically. It is not necessary to press the Return in order to set a number.

In the previous example of display 2), parameter number "50" is entered to display the prompt character string of that parameter/monitor. When the f2 DATA key is pressed here, display 3) appears and displays the current value of the parameter/monitor.

If a nonexistent number is entered, both the data and comment displays show the comment in display 4).

1) Initial display

```
#001:+HOT_ErrEn
-Mon- DATA N/P
```

Cursor

2) Displaying comment

```
#050: Position bandwidth
-Mon- DATA N/P
```

3) Displaying data

```
#050: 12
-Mon- CMNT N/P
```

4) Displaying comment (when a number does not exist)

```
#000:-----
-Mon- DATA N/P
```

(CMNT)

f2 DATA: Switches display; to the data display  
 CMNT: To the comment (prompt) display  
 f3 N: To the next display  
 f7 P: To the previous display  
 0 to 9: Each character is entered.  
 ← and → keys: Moves the cursor on the parameter/monitor number to the left or right.  
 ↑ and ↓ keys: Increases/decreases the numeric value of the digit indicated with the cursor.

Parameter/monitor number setting area

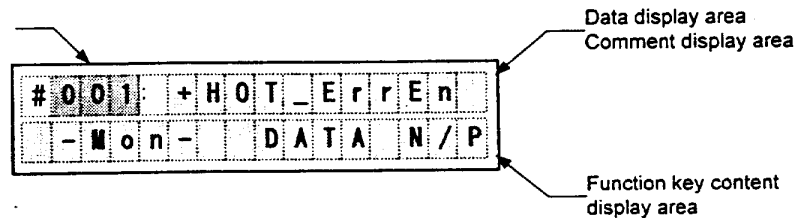

# 8 Operation Display Pendant

## 8.6 Parameter Settings Display

This display is for changing the values of parameters.

When you input a parameter number from the keypad, the display shows a prompt for the parameter when comments are being displayed, and the current value of the parameter when data is being displayed.

When data is being displayed, it is possible to move the cursor to the data setting area using the ← and → keys. In the data setting area (sign part), it is possible to reverse the sign by pressing the - key. In the data setting area (absolute value part), the setting value can be set using the numeric keys as well as the ↑ and ↓ keys. When you press the Return key, the entered data is set as the parameter value of the parameter number (the Return key is accepted only when data is being displayed).

When the data is set, the setting result is displayed. If it is set normally, the display shows "OK!" If it failed to set, the display shows "NG! [ERROR ALARM CODE]". When you press the f2 DATA key, the display switches to the data display; when you press the numeric keys or the ↑ and ↓ keys, it switches to the comment display. In the previous example of display 2), the parameter number "50" is entered to display the prompt character string of that parameter/monitor. If the f2 DATA key is pressed here, display 3) appears and displays the current value of the parameter/monitor. Display 4) shows the status in which the cursor is moved and data is input from the keypad. When the Return key is pressed here, the setting result is displayed as in display 5).

If a nonexistent number is entered, both the data and comment displays show the comment in display 6). In addition, if you input a parameter that exists but cannot be written to, the data display (but not the comment display) changes similarly to display 6).

1) Initial display

```
#001:+HOT_ErrEn
-Set- DATA N/P
```

Cursor

2) Displaying comment

```
#050: Position bandwidth
-Set- DATA N/P
```

3) Displaying data

```
#050: 000000012
-Set- CMNT N/P
```

4) Setting data

```
#050:-000000018
-Set- CMNT N/P
```

5) Displaying setting result

```
#050:NG![ALM62.0
-Set- DATA N/P
```

6) Displaying comment (when a number does not exist)

```
#000:-----
-Set- DATA N/P
(CMNT)
```

f2 DATA:

Switches display; to the data display

CMNT:

To the comment (prompt) display

f3 N:

To the next display

f7 P:

To the previous display

0 to 9:

Each character is entered.

-:

The sign of the data value is reversed if pressed while the cursor is at the data setting area (sign part).

Return key:

Sets the input data to the driver.

← and → key:

Moves the cursor in the parameter number setting area and data setting area (absolute value part) to the left or right.

↑ and ↓ key:

Increases/decreases the numeric value of the digit indicated by the cursor.

Parameter number setting area

```
# 0 0 1 : + H O T _ E r r E n
- S e t - D A T A N / P
```

Comment display area

Function key content display area

Parameter number setting area

```
# 0 0 1 : 0 0 0 0 0 0 0 0 0 0
- S e t - C M N T N / P
```

Data setting area (sign part)

Data setting area (absolute value part)

Function key content display area

## 8.7 I/O Monitor Display

The I/O signal status of the blocks with numbers input from the keypad for the selected I/O type is displayed periodically. It is not necessary to press the Return key in order to set a number.

There are three types of I/O that can be selected: "PLC I," "PLC O," and "Drv I." You can switch among them by pressing the f2/f6 SEL key.

In the previous example of display 2), block number "1" is entered to display the signal status of PLC DI block 1. If the f2/f6 SEL key is pressed here, the display changes similarly to display 3) and switches to the PLC DO display.

1) Initial display

```

PLC I00:xxxxxxxx
-I/O- SEL N/P
    
```

Cursor

2) Displaying PLC DI

```

PLC I01:xxxxxxxx
-I/O- SEL N/P
    
```

3) Displaying PLC DO

```

PLC O00:xxxxxxxx
-I/O- SEL N/P
    
```

f2 SEL: Switches I/O signal type (positive direction).  
 To the next display  
 f3 N: Switches I/O signal type (opposite direction).  
 f6 SEL: Switches I/O signal type (opposite direction).  
 f7 P: To the previous display

0 to 9: Each character is entered.  
 ← and → key: Moves the cursor in the I/O signal block number setting area to the left or right.  
 ↑ and ↓ key: Increases/decreases the numeric value of the digit indicated by the cursor.

PLC I  
 Block number 0: DI07 to DI00  
 1: DI15 to DI08

PLC O  
 Block number 0: DO07 to DO00  
 1: DO15 to DO08

Drv I (Driver input signal status)  
 Block number 0: DI07 to DI00  
 1: DI15 to DI08

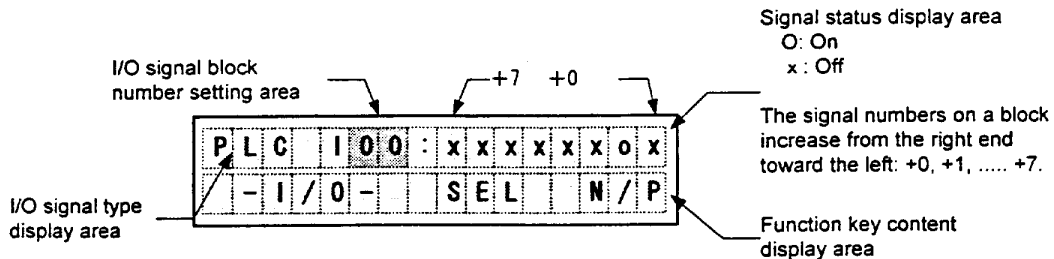

### Driver input signal status

DI00: (Reserved)	DI08: (Reserved)
DI01: (Reserved)	DI09: (Reserved)
DI02: (Reserved)	DI10: (Reserved)
DI03: (Reserved)	DI11: (Reserved)
DI04: Homing detection	DI12: (Reserved)
DI05: (+) direction over-travel detection	DI13: (Reserved)
DI06: (-) direction over-travel detection	DI14: (Reserved)
DI07: (Reserved)	DI15: (Reserved)

## 8.8 Special Command Display

In this display, you can transmit selected commands to the controller.

The selection of the commands you can choose from depends on the main operation mode. They can be switched by pressing the f2/f6 SEL key.

When you select a command from the list and press the Return key, it is transmitted to the controller and the result of the command is shown in the display. By pressing the f2/f6 SEL key, it is switched to the command content display.

In the previous example of display 2), command "toMode15" is selected. When you press the Return key, this command is transmitted to the controller and the result of the command is displayed in display 3).

Command	Display	Main operation mode	
		RS232C main operation mode	PLC main operation mode
Abort	CMD:Abort	○	○
Error reset	CMD:RstErr	○	○
Servo ON	CMD:SrvOn	○	X
Servo OFF	CMD:SrvOff	○	X
Mechanical setting operation start	CMD:toMode15	○	○
Software driver reset	CMD:RstDrive	○	○
Motor type request	CMD:MotorType	○	○
ROM version request	CMD:ROM Version	○	○
Error status request/refresh	CMD:RefErrSts	○	○

1) Initial display

CMD:Abort  
-SpC- SEL N/P

f2 SEL: Switches command (positive).  
f3 N: To the next display  
f6 SEL: Switches command (opposite).  
f7 P: To the previous display

2) Displaying command

CMD:toMode15  
-SpC- SEL N/P

Return key: Transmits the selected command to the driver.

3) Displaying command result

Mode15 Exec!  
-SpC- SEL N/P

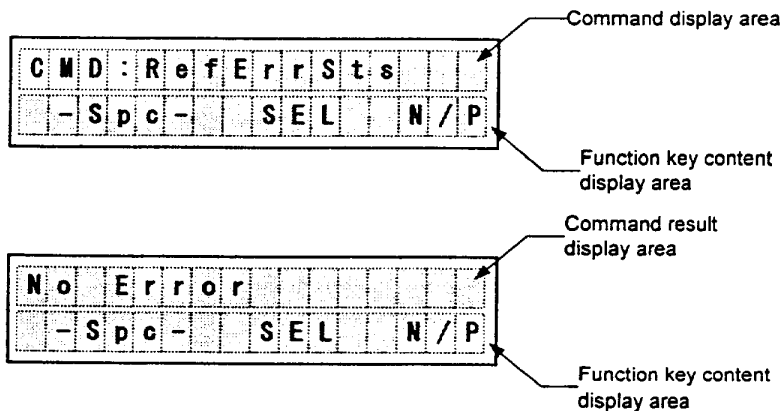

## 8.9 Program Menu Display

In the program menu display, you can edit, copy, and delete programs.  
By pressing the f1, f2, or f3 key in the initial display 1), you can jump to each operation.

Note: A special display for showing the registration status of a program file is not available. If you wish to verify the registration status, use the program load display in the program edit displays. Once you have verified, press the f3 CAN key to return to the program menu display.

1) Initial display

```

Program Menu
EDT CPY DEL N/P
    
```

f0 EDT:	To the program edit displays
f1 CPY:	To the program copy displays
f2 DEL:	To the program delete display
f3 N:	To the next display
f7 P:	To the previous display

### 8.9.1 Program Edit Displays

In the program edit displays, you operate in the order of program load, program edit, and then program save.

(1) Loading a program

You can select a program file number and load it into the editor.

When choosing the program file number of the source file, the stored program file number with the smallest number is displayed initially. If all the user area files are empty, a built-in program file is displayed initially.

1) Program file number selection

```

No90[o0024]
-EditPrg- CAN
    
```

f3 CAN:	Cancels To the program menu display
0 to 9:	Each character is entered.
Return key:	Loads the selected program file.
← and → key:	Moves the cursor in the program file number setting area to the left or right.
↑ and ↓ key:	Increases/decreases the numeric value of the digit indicated by the cursor.

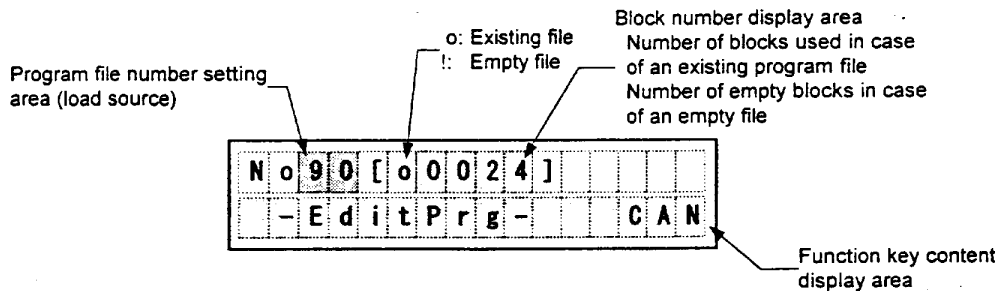

## (2) Editing a program

You can edit the content of a program loaded to the editor.

A block is treated as one unit in the editing. If a comment statement is attached to an NC executable statement, parameter statement, or control parameter in one line, that line occupies two blocks. Other lines occupy one block. The program edit function in the operation display pendant can handle up to 100 blocks. If you wish to edit more than that, use the PC utility.

Comment statements cannot be edited by the program edit function in the operation display pendant. However, it is possible to delete the block.

Moreover, a block attached to an NC executable statement, parameter statement, or control parameter in one line is treated specially. The NC executable statement, parameter statement, and control parameters are treated as the main blocks and their block numbers are displayed. Main blocks can be edited. Comment statements are treated as sub-blocks and their block numbers are not displayed. Since these blocks are comment statements, they cannot be edited. It is possible to delete a sub-block, but it is not possible to insert a block in front of a sub-block.

1) Initial display in case of an existing file (in case of a block that cannot be edited)

```
01 'Index operation
   I/D /C
```

2) Initial display in case of an existing file (in case of a block that can be edited)

```
01 #108=1
<# > S/= I/D :/C
```

3) Initial display in case of an empty file

```
01 _
<# > S/= I/D :/C
```

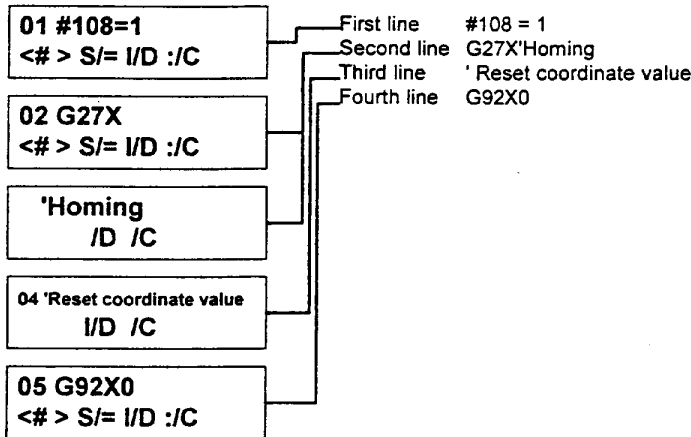

Characters in <>: #, G, X, F, f, A, a, M, P,  
 WH (WHILE), FR (FOR),  
 IF (IF), ED (END),  
 EI (ELSEIF), EL (ELSE),  
 >, <, !, +, %

Block number  
 display area

Edit area

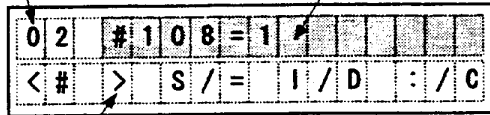

Function key content  
 display area

- f0 <>: Character selection (positive direction)  
 The character in <> changes at every key press.
- f1 S: Inputs the selected character.  
 The character in <> is input by pressing this key.
- f2 I: Inserts a block.  
 Inserts an empty block before the current line.
- f3 : Inputs
- f4 <>: Selects character (opposite direction).  
 The character in <> changes at each key press.
- f5 =: Inputs =.
- f6 D: Deletes a block.
- f7 C: Cancels  
 To the program menu display
  
- 0 to 9: Each character is input.  
 -, \*, /
  
- INS key: Shifts the character string one character after  
 the cursor position and insert a space at the  
 cursor position.
- DEL key: Deletes the character immediately before the  
 cursor. The cursor does not move.
- BS key: Deletes the character immediately before the  
 cursor and move the cursor to the position one  
 character before.
- Return key: To the program save function with the edited  
 content
- ← and → key: Moves the cursor on a block to the left or right.
- ↑ and ↓ key: Moves up or down within the editor buffer.  
 If the ↓ key is pressed at the last non-empty  
 line, an empty line is inserted after that line.

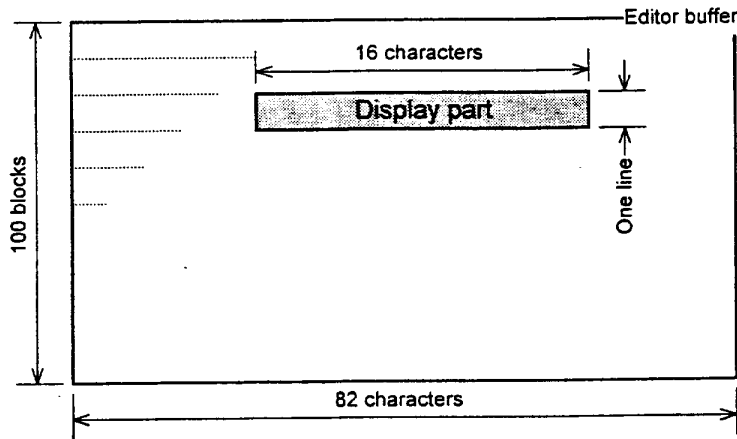



### (3) Saving a program

You can select a program file number to save the program edited in the editor.

If you are editing a file in the user area, the number during loading is initially displayed as the program file number at the save destination.

If you are editing a built-in program, the empty file with the smallest number is displayed as the initial program file number at the save destination.

#### 1) When editing a file in the user area

```
No01[ 0024]>01 o
-EditPrg- e/C
```

f3 e: Edits  
To the program edit display

f1 c: Cancels  
To the program menu display

#### 2) When editing a built-in file

```
No90[ 0024]>00 !
-EditPrg- e/C
```

0 to 9: Each character is input.

Return key: Loads the selected program file.

← and → key: Moves the cursor in the program file number setting area to the left or right.

↑ and ↓ key: Increases/decreases the numeric value of the digit indicated by the cursor.

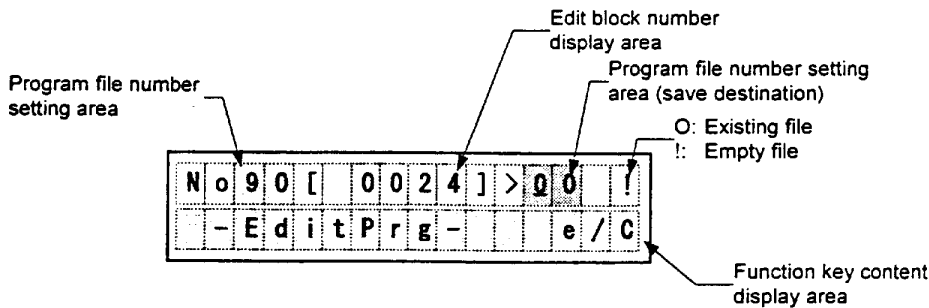

### (4) Displaying program save result

This display shows the result of the program save operation.

If the program is properly saved, the display shows similar to display 1). After confirming that the file is saved, press the f3 END key to return to the program menu display.

If the program is not properly saved, the display shows similar to display 2). Press the f3 e key to return to the program editor where blocks that were not properly processed are displayed. Make corrections and save the program again. Press the f7 C key to return to the program menu display.

#### 1) When a file is properly saved

```
R00
-EditPrg- END
```

f3 END: Ends  
To the program menu display

#### 2) When a file is not properly saved

```
Cannot interpret command
-EditPrg- e/C
```

f3 e: Edits  
To the program edit display

f7 c: Cancels  
To the program menu display

← and → key: Scrolls the message display area horizontally.

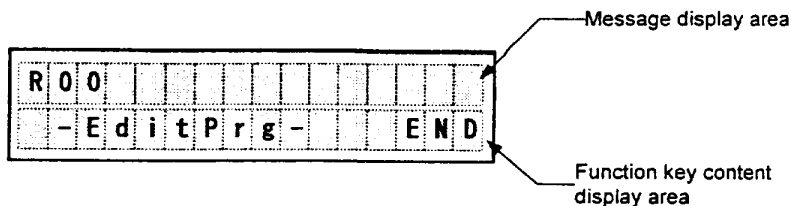

## 8.9.2 Copying a Program

### (1) Selecting a program

You can copy a program by selecting the program file numbers of the copy source and destination. When choosing the program file number of the copy source, the stored program file number with the smallest number is displayed initially. If all the user area files are empty, a built-in program file is displayed initially. When choosing the program file number of the copy destination, the empty file with the smallest number is displayed initially.

#### 1) Program file number selection

```
No90[o0024]>00 !
-CopyPrg- CAN
```

- f3 CAN: Cancels  
To the program menu display
- 0 to 9: Each character is input.
- Return key: Copies the selected copy source program to the copy destination program file.
- ← and → key: Moves the cursor in the copy source and destination program file number setting areas to the left or right.
- ↑ and ↓ key: Increases/decreases the numeric value of the digit indicated by the cursor.

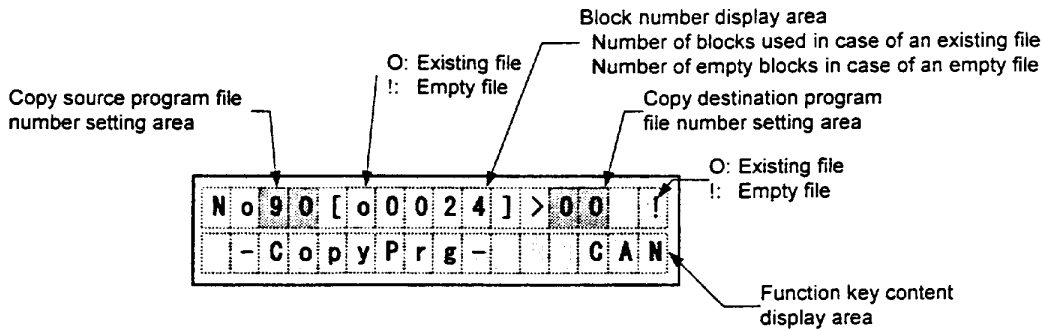

### (2) Displaying program copy result

This display shows the result of the program copy.

If the program is properly copied, the display shows similar to display 1). After confirming that the file is saved, press the f3 END key to return to the program menu display.

If the program is not properly copied, the display shows similar to display 2). After confirming this, press the f3 END key to return to the program menu display.

#### 1) When the file is properly copied

```
R00
-CopyPrg- END
```

- f3 END: Ends  
To the program menu display
- ← and → key: Scrolls the message display area horizontally.

#### 2) When the file is not properly copied

```
Cannot interpret command
-CopyPrg- END
```

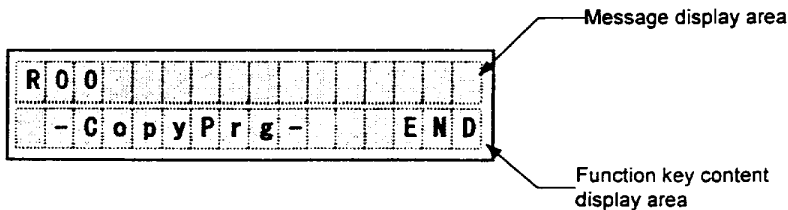

## 8.9.3 Deleting a Program

### (1) Selecting a program

You can select a program file number to delete that program.

When choosing the program file number to be deleted, the stored program file with the smallest number is displayed initially similar to display 1). If all the user area files are empty, the display shows similar to display 2).

#### 1) Program file number selection

```
No00[o0024]
-DelPrg- CAN
```

f3 CAN: Cancels  
To the program menu display

0 to 9: Each character is input.

#### 2) When the user area contains only empty files

```
None Prg
-DelPrg- CAN
```

Return key: Deletes the selected program file.

← and → key: Moves the cursor in the program file number setting area to the left or right.

↑ and ↓ key: Increases/decreases the numeric value of the digit indicated by the cursor.

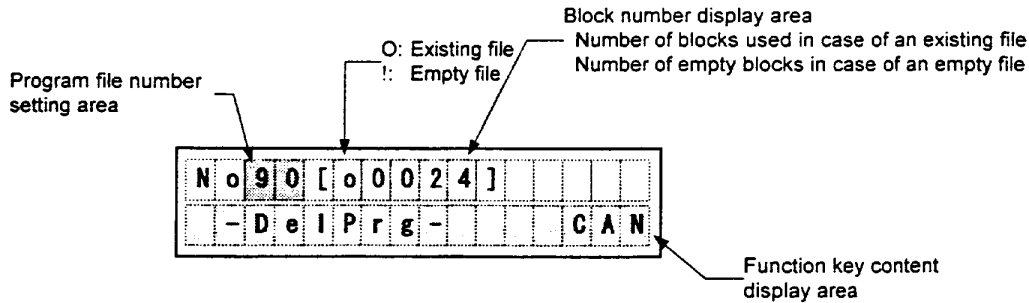

### (2) Displaying program delete result

This display shows the result of the program delete.

If the program is properly deleted, the display shows similar to display 1). After confirming that the file is deleted, press the f3 END key to return to the program menu display.

If the program is not properly deleted, the display shows similar to display 2). After confirming this, press the f3 END key to return to the program menu display.

#### 1) When the program is properly deleted

```
R00
-DelPrg- END
```

f3 END: Ends  
To the program menu display

← and → key: Scrolls the message display area horizontally.

#### 2) When the program is not properly deleted

```
Cannot interpret command
-DelPrg- END
```

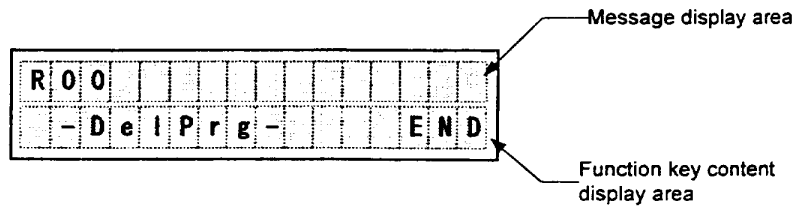

# Chapter 9

## Maintenance and Inspection

---

- 9.1 Maintenance and Inspection of the Motor Part
- 9.2 Maintenance and Inspection of the Driver Part
- 9.3 Replacing the Battery for Memory Backup
- 9.4 Backup and Restore Operations of Driver Memory Contents
  - 9.4.1 Backup Operation
  - 9.4.2 Restore Operation
- 9.5 Motor Problems and Corrective Actions

## 9.1 Maintenance and Inspection of the Motor Part

Simple daily checks need be performed on the motor part. Check the motor for excessive noise or abnormal vibration.

Do not dismount the motor.

If the motor operates abnormally after 20,000 hours of operation or five years since installation, depending on the environment and conditions used, replace the motor, and also the servo driver if necessary.

## 9.2 Maintenance and Inspection of the Driver Part

There is no need for a daily maintenance and inspection of the driver part. However, it is prudent to clean the driver unit periodically to protect it from dust or particles since they may damage insulation.

## 9.3 Replacing the Battery for Memory Backup

A lithium battery is provided inside the driver in order to store parameter data in memory. The life span of the lithium battery is normally 20,000 hours.

When the battery reaches the end of its life, an alarm signal will be displayed. When this happens, replace the battery as soon as possible.

The following describes the procedure used to replace the battery:

- 1) Back up parameters, programs, cam data and other important data stored in memory to flash ROM before replacing the battery. (For details on memory backup, see Section 9.4.)
- 2) Turn OFF the power.
- 3) Remove the six screws located on the side panel of the driver. (See the figure below.)

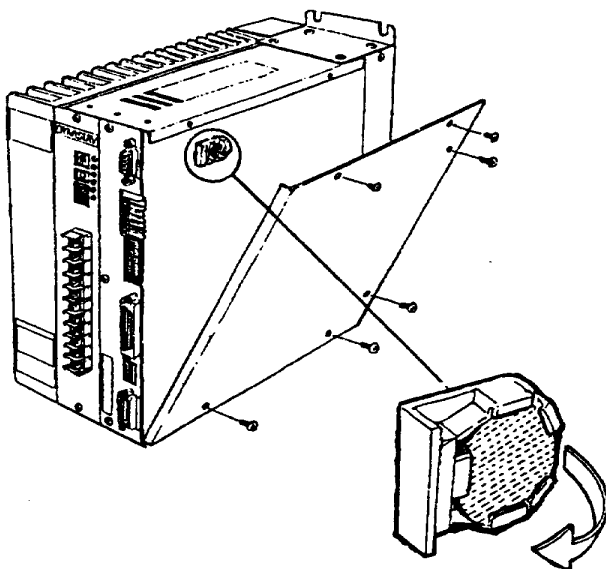

- 4) Replace the battery quickly (within 10 seconds).
- 5) Check the connection and turn ON the power. If no error is displayed, the battery has been replaced correctly.

Note 1: If a battery error is displayed, it is necessary to reset the system after replacing the battery. In this case, parameters and other data must be set again.

Note 2: Be sure to use <CR2032> 3V or equivalent battery. Be careful on the front and back orientation of the battery.

## 9.4 Backup and Restore Operations of Driver Memory Contents

Be sure to back up the driver memory contents in case of the occurrence of problems. If a problem occurs in the driver memory contents, it may become necessary to initialize (all reset) the driver to the same settings at the time of shipment from the factory. If the driver memory contents have been backed up in such a case, the driver memory contents can easily be restored to the factory settings.

### 9.4.1 Backup Operation

It is recommended to back up the driver memory contents to a file using the PC utility as well as to back up the driver memory contents to the driver's built-in flash ROM.

[Backup to a file using the PC utility]

Using the PC utility, back up the driver memory contents to an electronic file in the personal computer. Perform the following backup operation using the PC utility:

- Parameters upload
- Programs upload (batch)
- Index equal division compensation upload (batch)
- Index unequal division upload (batch)
- Parts upload (batch)
- I/O settings upload

[Backup to the driver's built-in flash ROM]

Back up the driver memory contents to the on-board flash ROM by copying the driver memory contents to the driver's built-in flash ROM in a batch operation.

Set the slide switch on the front panel as shown in the figure below, and turn ON the power. When the CRDY lamp flashes after several seconds, the backup operation is completed.

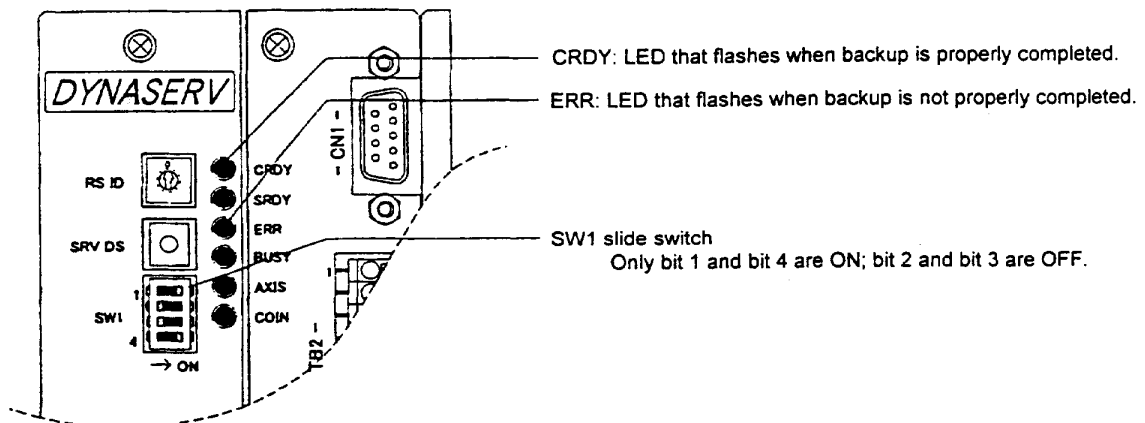

### 9.4.2 Restore Operation

The restore operation uses either of the backup data that was copied to a file via the PC utility or that was copied to the driver's built-in flash ROM. Perform either of the following restore operations:

[Restore using the PC utility]

Using the PC utility, restore the backed up driver memory contents to an electronic file in the personal computer to the driver. Perform the following restore operation using the PC utility:

- Parameters download
- Programs download (batch)
- Index equal division compensation download (batch)
- Index unequal division download (batch)
- Parts download (batch)
- I/O settings download

[Restore from the driver's built-in flash ROM]

Restore the driver memory contents from the on-board flash ROM by copying the driver memory contents to the driver's built-in flash ROM in a batch operation.

Set the slide switch on the front panel as shown in the figure below, and turn ON the power. When the CRDY lamp flashes after several seconds, the restore operation is completed.

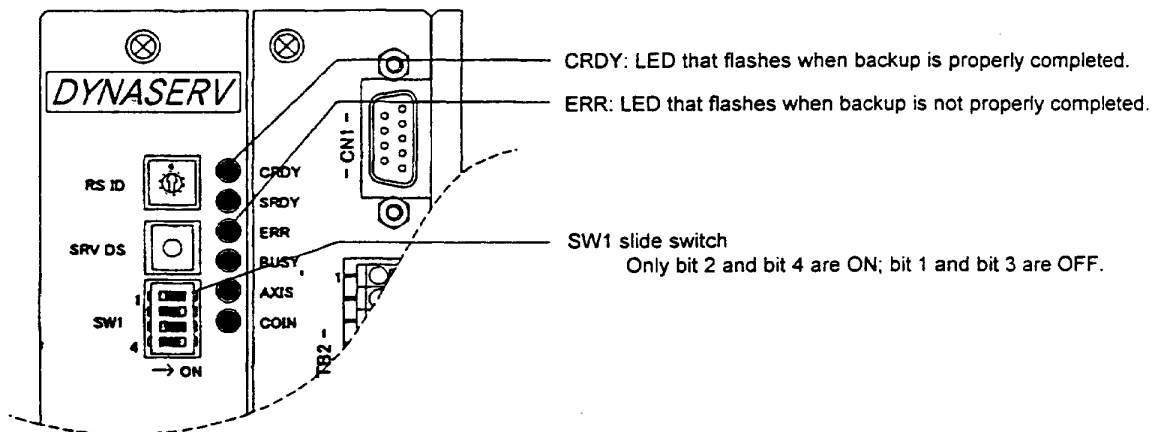

## 9.5 Motor Problems and Corrective Actions

When an abnormality occurs during motor operation, first check the LED display on the front panel of the driver. If the cause of the problem cannot be determined by the indication of the LED display, take an appropriate corrective action as provided below.

If the driver is still not be able to return to a normal operating condition despite corrective actions taken, stop operating the drive and contact us.

Problem	Possible cause	Item(s) to be inspected	Corrective action
The motor does not servo-lock.	◆ No AC power is being supplied.	Check the wiring.	Turn on the power.
	◆ The servo ON terminal is set to H.	Inspect.	Set to L.
	◆ The Servo ON disable (SRVDS) button is being pressed.	Inspect.	Release the button.
	◆ Position control bandwidth, velocity control bandwidth, and/or position integral limiting value are too small.	Inspect.	Adjust to the proper value(s) or perform auto-tuning.
The motor does not start.	◆ Motor is overloaded.	Check to see if the motor operates without any load.	Reduce the load or replace a motor with higher torque if the motor starts.
	◆ Incorrect external wiring	Inspect the wiring.	Refer to the connection diagram and connect correctly.
	◆ Position control bandwidth, velocity control bandwidth, and/or position integral limiting value are too small.	Inspect.	Adjust to the proper value(s) or perform auto-tuning.
The motor rotation is unstable.	◆ Improper connections	Check the motor connections in phases A, B, C, and GND.	Refer to the connection diagram and connect correctly.
	◆ Incorrect motor/driver model combination	Check the model numbers on the rating nameplates.	If the combination is incorrect, change to the correct combination.
The motor overheats.	◆ Ambient temperature is too high.	Check if the ambient temperature is above 45°C.	Lower the ambient temperature to 45°C or less.
	◆ Motor is overloaded.	Check to see if the motor operates without any load.	Reduce the load or replace a motor with higher torque if the motor starts.
Abnormal sounds are generated.	◆ Improper mounting	Mounting screws are loosened.	Tighten the screws.
	◆ Bearing problem	Check for abnormal sound and vibration from the bearings.	Motor replacement is necessary. (Contact us.)
	◆ Mounting base vibration	Check the mounting base.	Reinforce the mounting base.
Motor torque is too small.	◆ Incorrect motor/driver model combination	Check the model numbers on rating nameplates.	If the combination is incorrect, change it to the correct combination.
	◆ Motor is overloaded.	Check the OVL error signal.	Review the operation. Reduce the load.
	◆ Position control bandwidth, velocity control bandwidth, and/or position integral limiting value are too small.	Inspect.	Adjust to the proper value(s) or perform auto-tuning.
Motor runs out of control.	◆ Incorrect motor/driver model combination	Check the model numbers on rating nameplates.	If the combination is incorrect, change it to the correct combination.
	◆ Improper connections	Check the motor/encoder connections	Refer to the connection diagram and connect correctly.





# Chapter 10

## Specifications

---

- 10.1 Standard Specifications
- 10.2 Torque - Speed Characteristics
- 10.3 External Dimensions (Unit: mm)
- 10.4 Restrictive Conditions for the Frequency of Repeated Operations (DR5000B Series Only)

# 10 Specifications

## 10.1 Standard Specifications

### (1) DM Series Motor

Item		Unit	A Series				
			DM1200A 00*1	DM1150A 00*1	DM1100A 00*1	DM1050A 00*1	
Motor + driver	Maximum output torque	N·m (kgf·m)	200 (20)	150 (15)	100 (10)	50 (5.0)	
	Rated number of revolutions (100/200V)	rps	0.5/1.0		1.0/1.0		
	Rotational positioning	Encoder resolution	p/rev	4,096,000			
		Repeatability accuracy	Sec	±1			
Absolute accuracy		Sec	±15				
Motor	Rotor inertia	kg·m <sup>2</sup>	167 x 10 <sup>-3</sup>	142 x 10 <sup>-3</sup>	119 x 10 <sup>-3</sup>	96 x 10 <sup>-3</sup>	
	Allowable axial load	Positive	4 x 10 <sup>4</sup> (4 x 10 <sup>3</sup> )				
		Negative	2 x 10 <sup>4</sup> (2 x 10 <sup>3</sup> )				
	Allowable moment load	N·m (kgf·m)	400 (40)				
	Axial displacement rigidity	Positive	mm/N	2 x 10 <sup>-6</sup> (2 x 10 <sup>-5</sup> )			
		Negative	(mm/kgf)	3 x 10 <sup>-6</sup> (3 x 10 <sup>-5</sup> )			
	Moment displacement rigidity	rad/ N·m (rad/kgf·m)	4 x 10 <sup>-7</sup> (4 x 10 <sup>-6</sup> )				
Mass	kg	29	24	19	14.5		
Height (refer to dimension diagram)	mm	188	163	138	113		

Item		Unit	B Series					
			DM1075B 00*1	DM1060B 00*1	DM1045B 00*1	DM1030B 00*1	DM1015B 00*1	
Motor + driver	Maximum output torque	N·m (kgf·m)	75 (7.5)	60 (6.0)	45 (4.5)	30 (3.0)	15 (1.5)	
	Rated number of revolutions (100/200V)	rps	1.0/2.0	1.0/1.5	1.0/2.0	1.5/2.0	2.0/2.0	
	Rotational positioning	Encoder resolution	p/rev	2,621,440				
		Repeatability accuracy	Sec	±1				
Absolute accuracy		Sec	±15					
Motor	Rotor inertia	kg·m <sup>2</sup>	27 x 10 <sup>-3</sup>	23 x 10 <sup>-3</sup>	19 x 10 <sup>-3</sup>	15 x 10 <sup>-3</sup>	12 x 10 <sup>-3</sup>	
	Allowable axial load	Positive	3 x 10 <sup>4</sup> (3 x 10 <sup>3</sup> )					
		Negative	1 x 10 <sup>4</sup> (1 x 10 <sup>3</sup> )					
	Allowable moment load	N·m (kgf·m)	200 (20)					
	Axial displacement rigidity	Positive	mm/N	2.5 x 10 <sup>-6</sup> (2.5 x 10 <sup>-5</sup> )				
		Negative	(mm/kgf)	3 x 10 <sup>-6</sup> (3 x 10 <sup>-5</sup> )				
	Moment displacement rigidity	rad/ N·m (rad/kgf·m)	1 x 10 <sup>-6</sup> (1 x 10 <sup>-5</sup> )					
Mass	kg	14	12	9.5	7.5	5.5		
Height (refer to dimension diagram)	mm	194	168	143	118	92.5		

Motor model name	DM1004B0F-2□*1	DM1004C0F-2□*1
Maximum torque (N·m)	4	
Maximum number of revolutions (rps)	2.5	
Encoder resolution (p/rev)	2,621,440	
Absolute accuracy (sec)	Note	
Repeatability accuracy (sec)	±3	
Axial rotational deflection (μm) <sub>p-p</sub>	10	
Radial rotational deflection (μm) <sub>p-p</sub>	10	
Rotor inertia (kg·m <sup>2</sup> )	5.5 x 10 <sup>-3</sup>	2.5 x 10 <sup>-3</sup>
Withstand load (N)	50	
Mass (kg)	3	3

Note: □: A/Absolute accuracy ±20 sec, B/Absolute accuracy ±60 sec

(2) DR Series Motor

Item		Unit	A Series						
			DR1400 A00*1	DR1300 A00*1	DR1200 A00*1	DR1150 A00*1	DR1100 A00*1	DR1050 A00*1	
Motor + driver	Maximum output torque	N·m (kgf·m)	400 (40)	300 (30)	200 (20)	150 (15)	100 (10)	50 (5.0)	
	Rated number of revolutions (100/200V)	rps	0.25/0.5		0.5/1.0		1.0/1.0	1.5/1.5	
	Rotational positioning	Encoder resolution	p/rev	1,638,400					
		Repeatability accuracy	Sec	±3					
		Absolute accuracy	Sec	±30					
Motor	Rotor inertia		kg·m <sup>2</sup>	400x10 <sup>-3</sup>	340x10 <sup>-3</sup>	285x10 <sup>-3</sup>	230x10 <sup>-3</sup>	200x10 <sup>-3</sup>	180x10 <sup>-3</sup>
	Allowable axial load	Positive	N (kgf)	4 x 10 <sup>4</sup> (4 x 10 <sup>3</sup> )					
		Negative		2 x 10 <sup>4</sup> (2 x 10 <sup>3</sup> )					
	Allowable moment load		N·m (kgf·m)	400 (40)					
	Axial displacement rigidity	Positive	mm/N (mm/kgf)	2 x 10 <sup>-6</sup> (2 x 10 <sup>-5</sup> )					
		Negative		3 x 10 <sup>-6</sup> (3 x 10 <sup>-5</sup> )					
	Moment displacement rigidity		rad/ N·m (rad/kgf·m)	4 x 10 <sup>-7</sup> (4 x 10 <sup>-6</sup> )					
	Mass		kg	65	55	45	36	31	26
Height (refer to dimension diagram)		mm	358	304	250	212	185	158	

Item		Unit	B Series					
			DR1060 B00*1	DR1045 B00*1	DR1030 B00*1	DR1015 B00*1	DR1008 B00*1	
Motor + driver	Maximum output torque	N·m (kgf·m)	60 (6.0)	45 (4.5)	30 (3.0)	15 (1.5)	8 (0.8)	
	Rated number of revolutions (100/200V)	rps	1.0/1.5	1.0/2.0	1.5/2.0	2.0/2.0		
	Rotational positioning	Encoder resolution	p/rev	1,015,808				
		Repeatability accuracy	Sec	±3				
		Absolute accuracy	Sec	±45				
Motor	Rotor inertia		kg·m <sup>2</sup>	33 x 10 <sup>-3</sup>	26 x 10 <sup>-3</sup>	24 x 10 <sup>-3</sup>	21 x 10 <sup>-3</sup>	15 x 10 <sup>-3</sup>
	Allowable axial load	Positive	N (kgf)	3 x 10 <sup>4</sup> (3 x 10 <sup>3</sup> )				
		Negative		1 x 10 <sup>4</sup> (1 x 10 <sup>3</sup> )				
	Allowable moment load		N·m (kgf·m)	200 (20)				
	Axial displacement rigidity	Positive	mm/N (mm/kgf)	3 x 10 <sup>-6</sup> (3 x 10 <sup>-5</sup> )				
		Negative		4 x 10 <sup>-6</sup> (4 x 10 <sup>-5</sup> )				
	Moment displacement rigidity		rad/ N·m (rad/kgf·m)	2 x 10 <sup>-6</sup> (2 x 10 <sup>-5</sup> )				
Mass		kg	15.5	13.0	11.0	9.0	6.0	
Height (refer to dimension diagram)		mm	207	179	151	123	85	

Item		Unit	E Series					
			DR1250E 00*1	DR1220E 00*1	DR1160E 00*1	DR1130E 00*1	DR1100E 00*1	
Motor + driver	Maximum output torque	N·m (kgf·m)	250 (25)	220 (22)	160 (16)	130 (13)	100 (10)	
	Rated number of revolutions (100/200V)	rps	0.5/1.0				1.0/1.5	
	Rotational positioning	Encoder resolution	p/rev	1,228,800				
		Repeatability accuracy	Sec	±3				
Absolute accuracy		Sec	±45					
Motor	Rotor inertia	kg·m <sup>2</sup>	185 x 10 <sup>-3</sup>	170 x 10 <sup>-3</sup>	140 x 10 <sup>-3</sup>	125 x 10 <sup>-3</sup>	100 x 10 <sup>-3</sup>	
	Allowable axial load	Positive	4 x 10 <sup>4</sup> (4 x 10 <sup>3</sup> )					
		Negative	2 x 10 <sup>4</sup> (2 x 10 <sup>3</sup> )					
	Allowable moment load	N·m (kgf·m)	400 (40)					
	Axial displacement rigidity	Positive	2 x 10 <sup>-6</sup> (2 x 10 <sup>-5</sup> )					
		Negative	3 x 10 <sup>-6</sup> (3 x 10 <sup>-5</sup> )					
	Moment displacement rigidity	rad/ N·m (rad/kgf·m)	4 x 10 <sup>-7</sup> (4 x 10 <sup>-6</sup> )					
	Mass	kg	48	44	36	32	26	
Height (refer to dimension diagram)	mm	355	327	271	243	210		

Item		Unit	E Series		
			DR1070E 00*1	DR1030E 00*1	
Motor + driver	Maximum output torque	N·m (kgf·m)	70 (7.0)	30 (3.0)	
	Rated number of revolutions (100/200V)	rps	1.5/2.0	1.5/2.0	
	Rotational positioning	Encoder resolution	p/rev	1,228,800	
		Repeatability accuracy	Sec	±3	
Absolute accuracy		Sec	±45		
Motor	Rotor inertia	kg·m <sup>2</sup>	85 x 10 <sup>-3</sup>	72 x 10 <sup>-3</sup>	
	Allowable axial load	Positive	4 x 10 <sup>4</sup> (4 x 10 <sup>3</sup> )		
		Negative	2 x 10 <sup>4</sup> (2 x 10 <sup>3</sup> )		
	Allowable moment load	N·m (kgf·m)	400 (40)		
	Axial displacement rigidity	Positive	2 x 10 <sup>-6</sup> (2 x 10 <sup>-5</sup> )		
		Negative	2 x 10 <sup>-6</sup> (3 x 10 <sup>-5</sup> )		
	Moment displacement rigidity	rad/ N·m (rad/kgf·m)	4 x 10 <sup>-7</sup> (4 x 10 <sup>-6</sup> )		
Mass	kg	22	18		
Height (refer to dimension diagram)	mm	183	156		

### (3) DR/5000 Series Motor

Item		Unit	5000 E Series		5000 B Series			
			DR5100E 00*1	DR5070E 00*1	DR5070B 00*1	DR5050B 00*1	DR5030B 00*1	
Motor + driver	Maximum output torque	N·m (kgf·m)	100 (10)	70 (7.0)	70 (7.0)	50 (5.0)	30 (3.0)	
	Rated number of revolutions (100/200V)	rps	/2.0		/4.0			
	Rotational positioning	Encoder resolution	p/rev	638,976		557,056		
		Repeatability accuracy	Sec	±4		±5		
		Absolute accuracy	Sec	±90		±90		
Motor	Rotor inertia	kg·m <sup>2</sup>	125 × 10 <sup>-3</sup>	100 × 10 <sup>-3</sup>	37 × 10 <sup>-3</sup>	34 × 10 <sup>-3</sup>	27 × 10 <sup>-3</sup>	
	Allowable axial load	Positive	4 × 10 <sup>4</sup> (4 × 10 <sup>3</sup> )		3 × 10 <sup>4</sup> (3 × 10 <sup>3</sup> )			
		Negative	2 × 10 <sup>4</sup> (2 × 10 <sup>3</sup> )		1 × 10 <sup>4</sup> (1 × 10 <sup>3</sup> )			
	Allowable moment load	N·m (kgf·m)	400 (40)		200 (20)			
	Axial displacement rigidity	Positive	2 × 10 <sup>-6</sup> (2 × 10 <sup>-5</sup> )		3 × 10 <sup>-6</sup> (3 × 10 <sup>-5</sup> )			
		Negative	3 × 10 <sup>-6</sup> (3 × 10 <sup>-5</sup> )		4 × 10 <sup>-6</sup> (4 × 10 <sup>-5</sup> )			
	Moment displacement rigidity	rad/ N·m (rad/kgf·m)	4 × 10 <sup>-7</sup> (4 × 10 <sup>-6</sup> )		2 × 10 <sup>-6</sup> (2 × 10 <sup>-5</sup> )			
	Mass	kg	32	26	18.0	16.0	13.5	
Height (refer to dimension diagram)	mm	243	210	240	212	184		

### (4) Motor Environment Specification

		Motor	Comment
Ambient operating conditions	Temperature	0 to 45°C	
	Humidity	20 to 85% R.H	Should have no condensation.
Ambient storage conditions	Temperature	-20 to 85°C	
	Humidity	20 to 85% R.H	Should have no condensation.
Operating environment		No corrosive gases and dust should be present.	

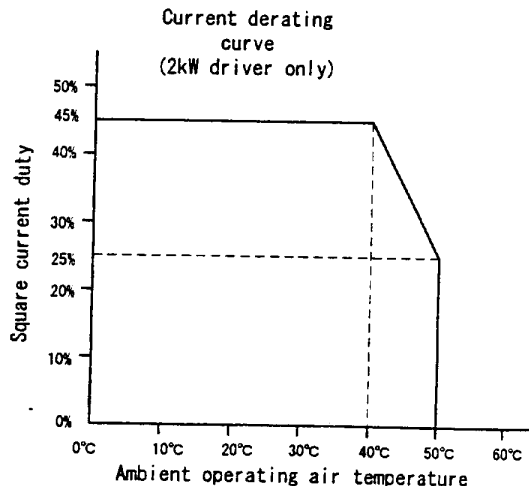

### (5) Driver Part (General Specifications)

Type	500W type		2kW type			
Model name	U□□□□□□□□AD-*□□_ U□□□□□□□□B□-*□□_		U□□□□□□□□K□-*□□_		U□□□□□□□□L□-*□□_	
Input power supply voltage	100 to 115V AC + 10%, -15% 50Hz/60Hz	200 to 230V AC + 10%, -15% 50Hz/60Hz	100 to 115V AC + 10%, -15% 50Hz/60Hz	200 to 230V AC + 10%, -15% 50Hz/60Hz	100 to 115V AC + 10%, -15% 50Hz/60Hz	200 to 230V AC + 10%, -15% 50Hz/60Hz
Maximum current consumption (KVA)	0.8		3.4		3.4	
Ambient operating air temperature and humidity	0 to 50°C, 20 to 90% RH, without condensation					
Ambient storage air temperature and humidity	-20 to 85°C, 20 to 90% RH, without condensation					
Operating environment	No corrosive gases and dust should be present.					
Mass (kg)	1.7		3.6		3.2	

\* Input voltage 100 to 115V AC: 1, 200 to 230V AC: 2

(6) Driver Function Specifications

Item		Specifications
Higher interface		RS232C interface (single channel communication, multi-channel communication) PLC interface (can be selected from the following four types at ordering: contact I/O, PROFIBUS-DP, CC-LINK, DeviceNet)
Input signal	Control input signal	Emergency stop, servo command, start, stop, operation number, code input (BCD 2-digit), error reset, integral position control operation disable, interlock, velocity override selection, jog (+) command, job (-) command, M answer input etc.
	Mechanical input signal	Homing signal, (+) direction hardware over-travel signal, (-) direction hardware over-travel signal
Output signal	Control input signal	CPU ready, servo ready, operation under execution, error status, alarm status, position settling status, area signal 0, area signal 1, M code enable, code output (BCD 2-digit) etc.
	Mechanical input signal	Brake signal
Position detector resolution		Rotating type Standard DMA series: 4096000 pls/rev, standard DMB series: 2621440 pls/rev, small-diameter/flat: 2621440 pls/rev Standard DRA series: 1638400 pls/rev, standard DRB series: 1015808 pls/rev, standard DRE series: 1228800 pls/rev High-speed DRB series: 557056 plc/rev, high-speed DRE series: 638976 pls/rev Linear Standard, high-stiffness series: 0.25 $\mu$ m, high-speed, high-speed/high-stiffness series: 0.5 $\mu$ m,
Coordinate system		Either rotational coordinates or linear coordinates can be selected. Command unit coordinate (rotating type): pulse, angle (1/100, 1/1000, 1/10000 degree), user setting unit (linear): pulse, angle (10 $\mu$ m, 1 $\mu$ m, 0.1 $\mu$ m), user setting units Operation unit: command unit, index Type A, index Type B
Control part	Method	I-PD position control (position: integral proportional control, velocity: proportional control) Various feed forward functions (position, velocity, acceleration) Various standard filters (velocity command filter, velocity feedback filter, first order delay filter) Optional filter (notch filter 2 channels)
	Adjustment	Position control bandwidth: 1 Hz to 32Hz, velocity control loop width: 5Hz to 200Hz Position integral limiter setting Various feed forward percentages (position, velocity, acceleration) Various standard filter settings (velocity command filter bandwidth, velocity feedback filter enable/disable, bandwidth, first order delay filter setting) Optional filter setting (notch filter bandwidth)  *1) Calculates proportional gain and acceleration feed forward gain of the velocity control part automatically based on measurement by the auto-tuning operation or manual setting of the load inertia/weight with respect to the settings of velocity control bandwidth and acceleration feed forward percentage. *2) Calculates position control bandwidth, velocity control loop bandwidth, and position integral limiting value automatically during execution of the auto-tuning operation or by manual setting of the servo stiffness.
Acceleration/deceleration control		Trapezoidal move: Acceleration curve and deceleration curve can be selected individually. Acceleration time or deceleration time can be selected individually (with respect to the maximum velocity). Cam profile move: Cam profile selection (8 standard parts and 8 user parts) Acceleration curve or deceleration curve at velocity override change can be selected individually. Acceleration time or deceleration time at velocity override change can be selected individually (ratio to override is 100%). Feed time setting or maximum velocity setting  *3) Real time override possible, interlock possible
Operation function		Jog move operation, test operation, auto-tuning operation, homing operation, signal search operation, index operation A, index operation B, table reference operation, program operation, MDI operation
	Program operation	No. of program blocks: 1000, No. of programs: 100 (including 10 fixed programs) Possible to change parameters and reference monitors in a program. IF statements, FOR statements, WHILE statements, and subprogram calls are possible. Possible to write programs that use variables (50 registration variables and 50 volatile variables). Step execution and repetitive execution are possible.



Item	Specifications
Protection functions	Encoder/resolver error, power module error (over-voltage and over current), main power supply error, overload, maximum velocity, excessive position deviation, hardware over-travel, software over-travel (only for linear coordinate)
Others	M function (2-digit) Support software PC utility running under Windows (optional) Possible to connect the operation display pendant (optional)
Monitor	Analogue signal monitor (velocity, general, torque/thrust command) For general monitoring, what is shown by the monitor can be selected by setting (position error, test operation response, position command value, current position value, position command differential value) Digital signal monitor (settling signal) Monitoring internal information by higher interface

# 10.2 Torque - Speed Characteristics

## (1) DM Series

— 200-230 VAC power supply  
 - - - 100-115 VAC power supply

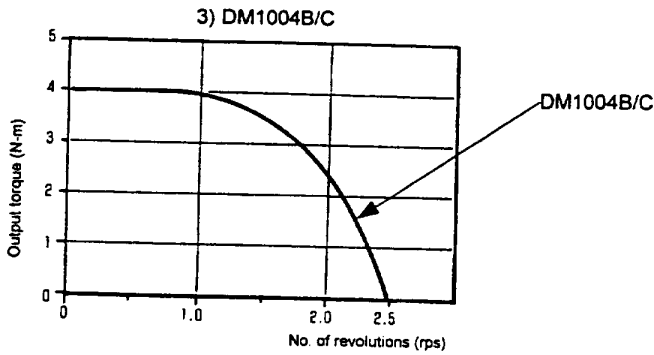
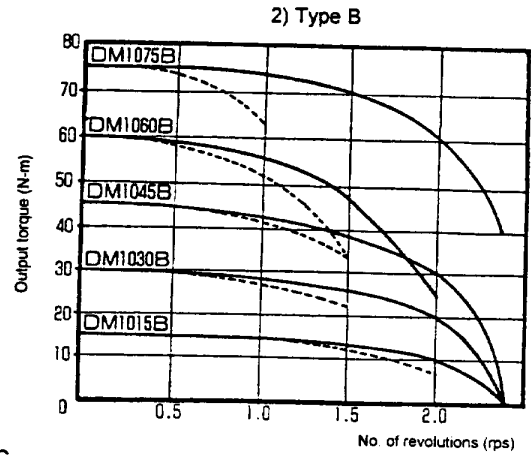
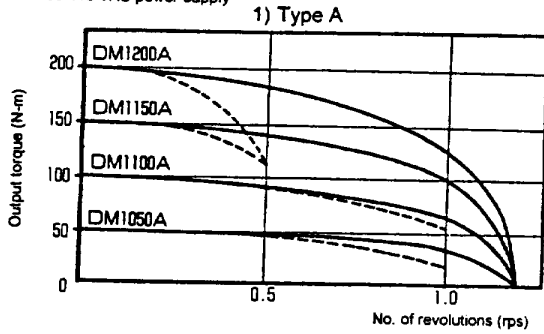

## (2) DR Series

— 200-230 VAC power supply  
 - - - 100-115 VAC power supply

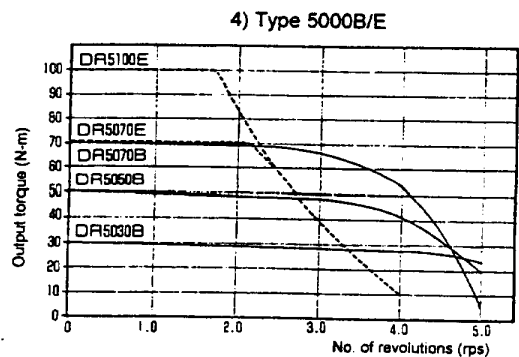
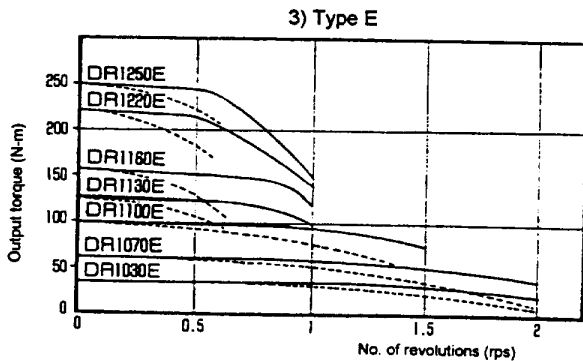
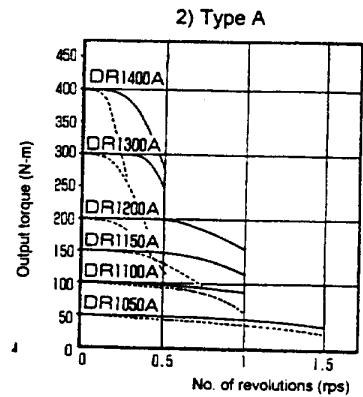
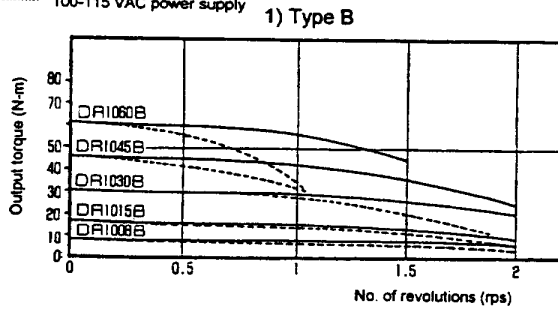

# 10 Specifications

## 10.3 External Dimensions (Unit: mm)

(1) DM Series Motor

1) Type A

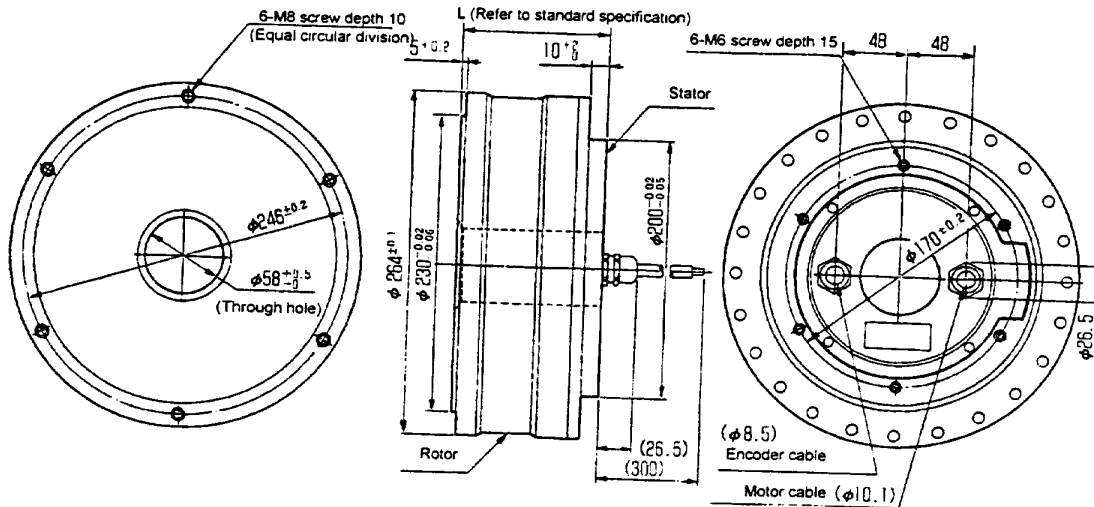

2) Type B

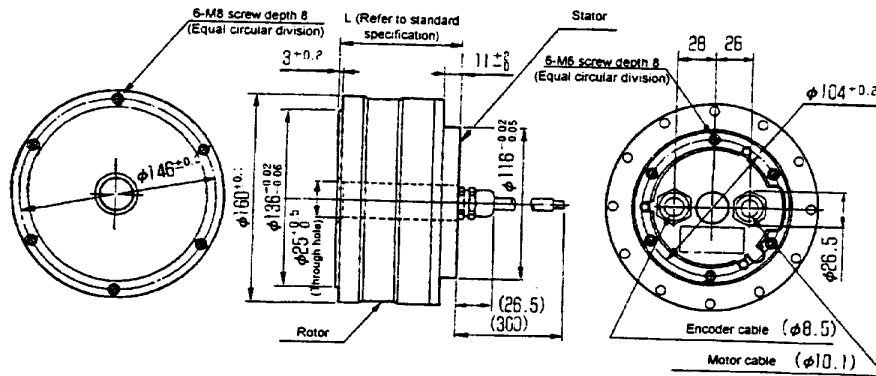

3) DM1004B/C

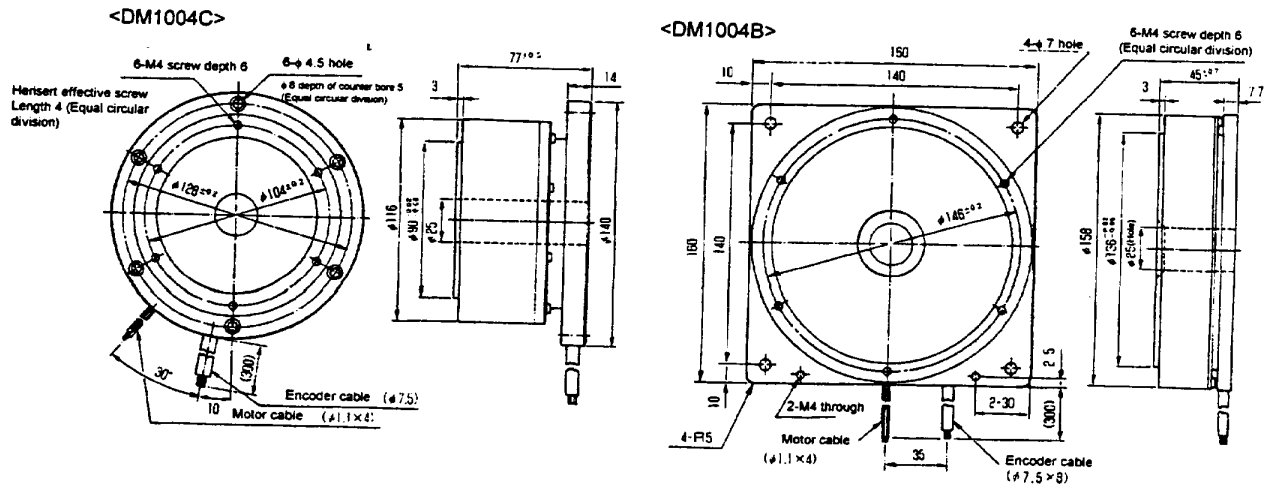

(2) DR Series Motor

1) Type A

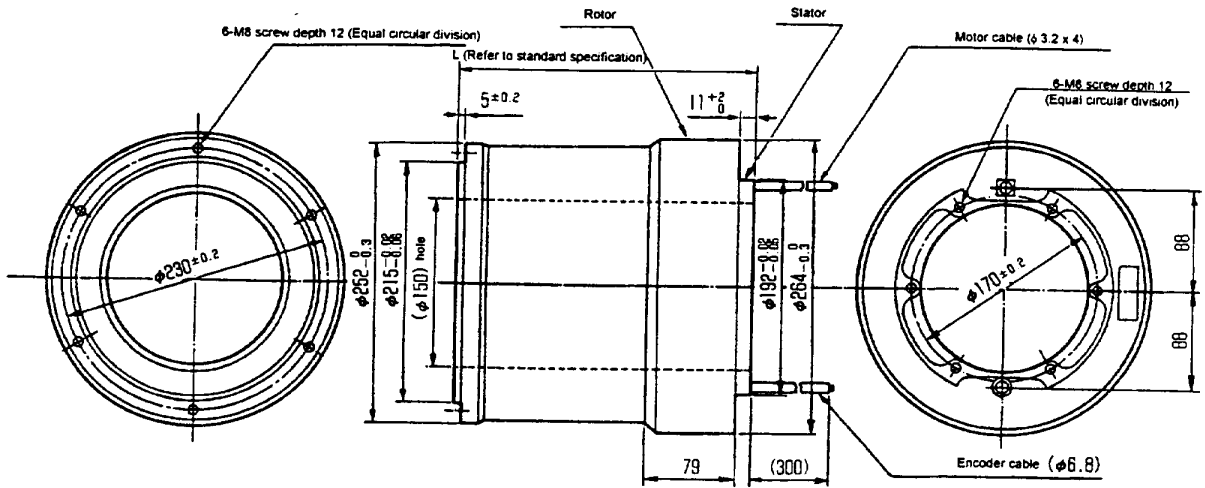

2) Type E

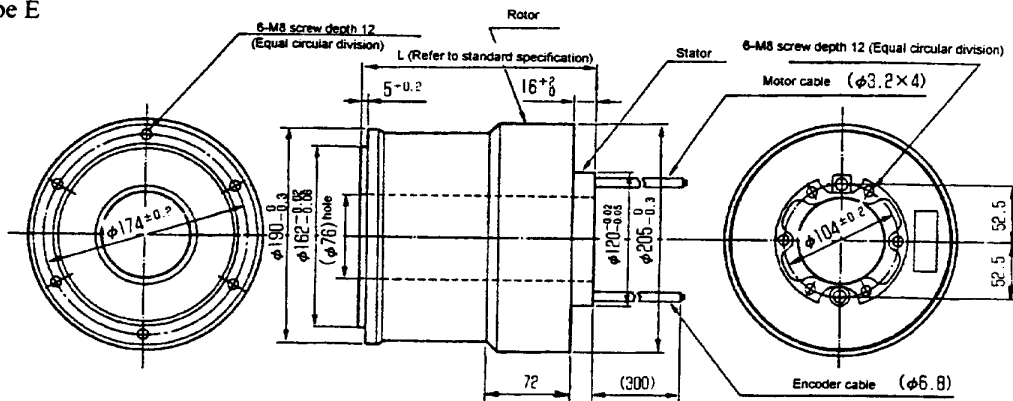

3) Type B

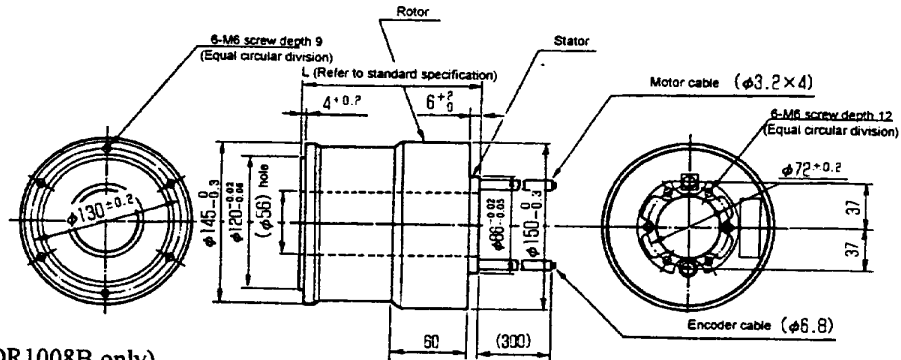

4) Type B (DR1008B only)

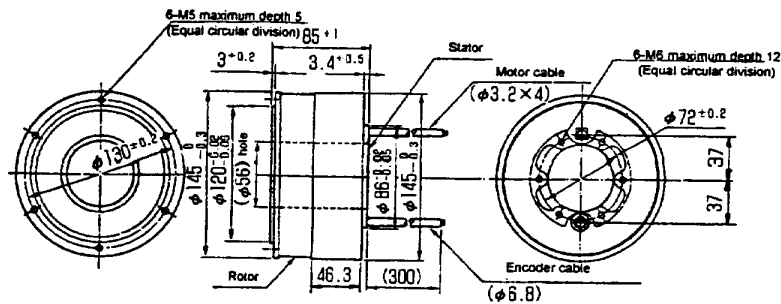

# 10 Specifications

## (3) Driver Section

- 1) U□□□□□□□□A/B  
(500W, Type B is shown in the figure.)

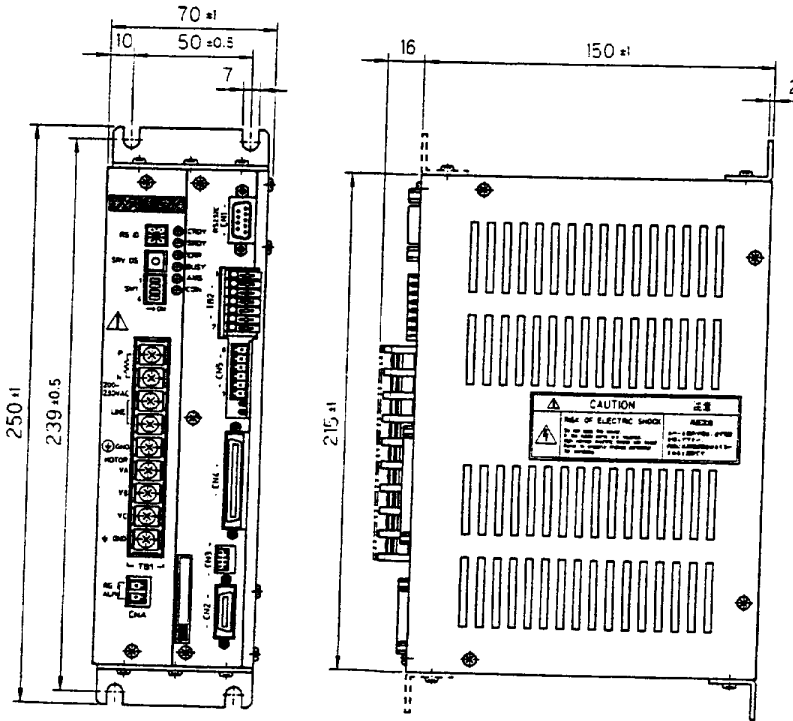

- 2) U□□□□□□□□L  
(2kW type without regenerative unit)

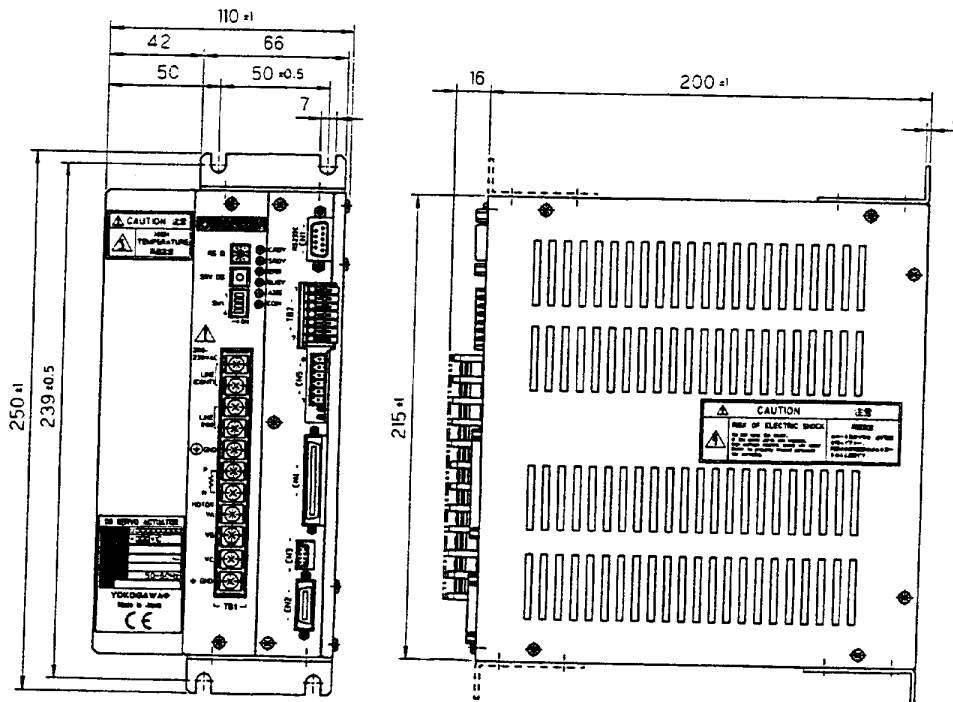

3) U□□□□□□□□K  
 (2kW type with regenerative unit)

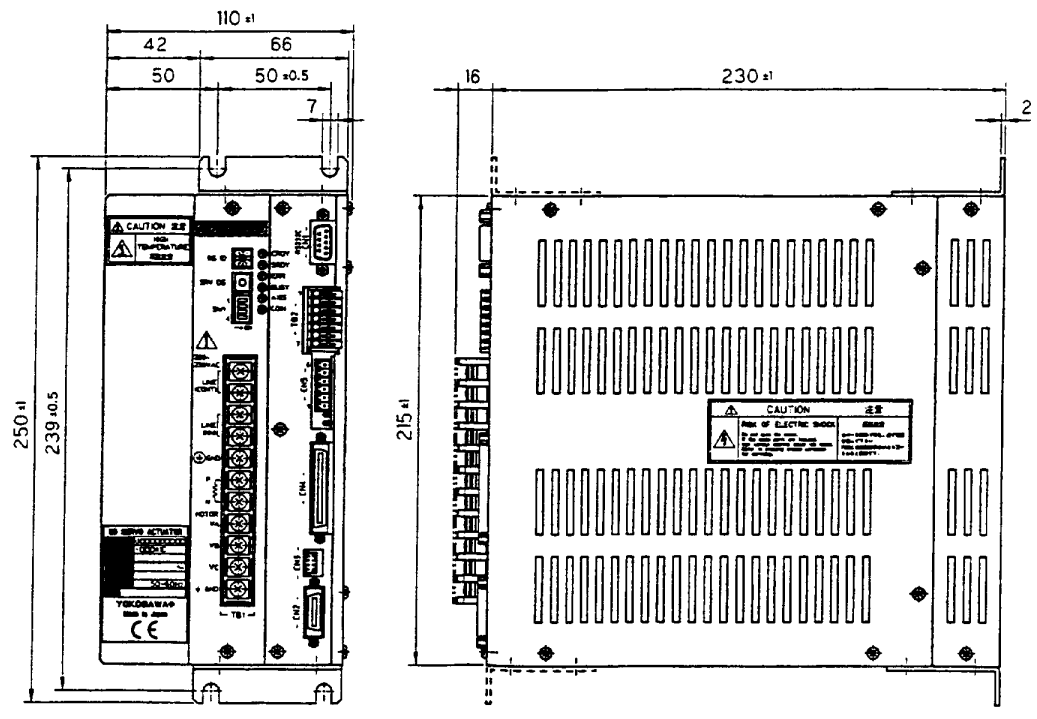

## 10.4 Restrictive Conditions for the Frequency of Repeated Operations (DR5000B Series Only)

When running and stop operations are performed repeatedly on DYNASERV DR5000B series (DR5030B, 5050B, 5070B) because of a high number of rated revolution, some restrictions may apply based on the characteristic of the motor and the driver with respect to the frequency of repeated running and stop operations. Consider those restrictions carefully when using the motor.

### (1) Restrictions on the motor

The operating conditions under which the motor rotates and stops repeatedly are set assuming that the motor is mounted on a metal stand, and the ambient temperature is 45°C.

When the motor is operated repeatedly with a cycle of acceleration, uniform speed, deceleration and stop, if the load conditions and the operation time are set as shown in Figure 10.1, it is necessary to satisfy the equations below.

In addition, if either the average speed (number of revolutions) or the current duty is known, the other can simply be obtained from the graph shown in Figure 10.2.

The motor, current and speed can actually be measured by the oscilloscope function (see Chapter 7) of the PC utility. Verify them with the monitor numbers listed below.

#365 Present velocity value  
#369 Present current value (A/D)

$$\eta^B = \frac{N_R}{2} (t_1 + 2t_2 + t_3) \times \frac{1}{5t_{CY}} \times 100 \quad \text{Equation (1)}$$

$$\eta^C = (t_1 I_1^2 + t_2 I_2^2 + t_3 I_3^2) \times \frac{1}{5t_{CY}} \times 100 \quad \text{Equation (2)}$$

$$\eta^B + 2.6 \cdot \eta^C < 103 \quad \text{Equation (3)}$$

$\eta^B$  = Velocity duty  
 $\eta^C$  = Current duty  
 $I_1, I_2, I_3$  = Current (A)  
 $N_R$  = No. of revolutions (rps)  
 $t_{CY}$  = Cycle time (msec)  
 $t_1, t_2, t_3$  = Time (msec)

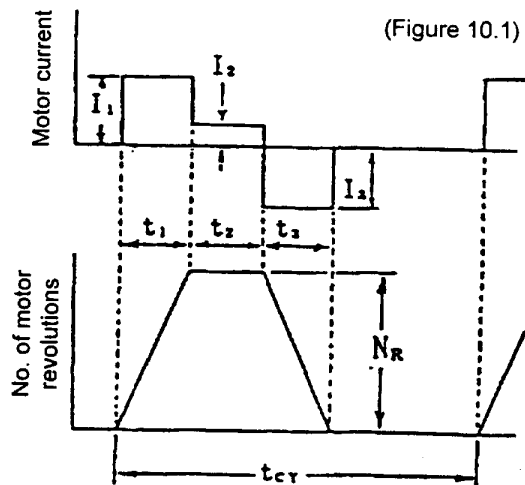
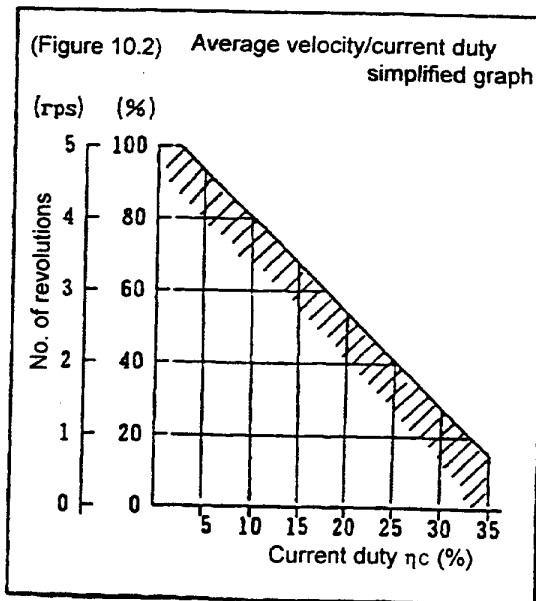

<Example>

$$N_R = 4 \text{ (rps)}$$

$$I_1 = I_3 = 9 \text{ (A)}$$

$$I_2 = 3 \text{ (A)}$$

$$t_1 = t_2 = t_3 = 1/4 t_{CY}$$

When calculating from the above setting example,

$$\begin{aligned} \eta^B &= \frac{4}{2} \left( \frac{1}{4} t_{CY} + \frac{2}{4} t_{CY} + \frac{1}{4} t_{CY} \right) \times \frac{1}{5 t_{CY}} \times 100 \\ &= \frac{2}{5} \times 100 = 40 \end{aligned}$$

$$\begin{aligned} \eta^C &= \left( \frac{81}{4} t_{CY} + \frac{9}{4} t_{CY} + \frac{81}{4} t_{CY} \right) \times \frac{1}{225 t_{CY}} \times 100 \\ &= \frac{17100}{900} = 19 \end{aligned}$$

When substituting the above into equation (3),

$$40 + 2.6 \times 19 = 98 < 103$$

Therefore, the result satisfies the equation, and the setting is deemed to be correct.

## (2) Restrictions on the driver

The repeat frequency caused by the driver is restricted by the heat generation of the driver's built-in regenerative resistor. If a repeated operation is performed using the pattern as shown in Figure 10.3, the repeat frequency, as shown in Figure 10.4, is restricted by the load inertia using the number of revolutions as a parameter. If the load inertia exceeds 1 kgm<sup>2</sup>, or if it is necessary to use on DYNASERV DR5000B series (DR5030B, 5050B, 5070B) outside of the limits, please contact Yokogawa.

(Figure 10.4)

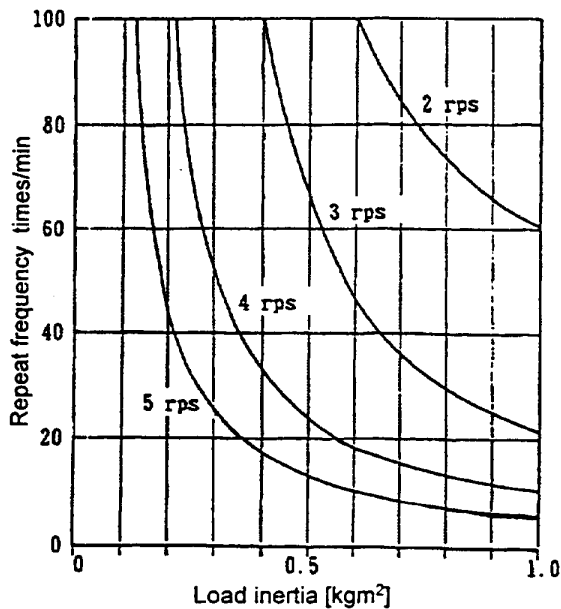

(Figure 10.3)

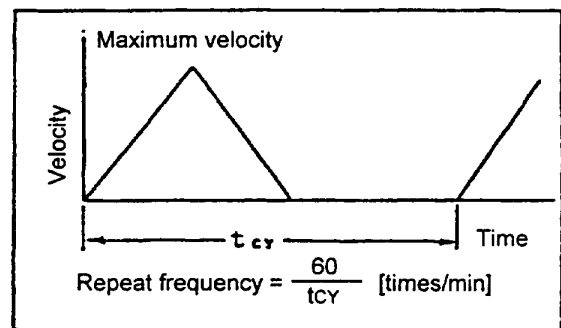





## Parameter List

STD1

Parameter No.	Parameter name	Minimum value	Maximum value	Initial value	Unit	Possible to change
1	Enables the over-travel error function in the + direction	0	1	0	None	Always
2	Enables the over-travel error function in the - direction	0	1	0	None	Always
3	Selecting the type of cam profile move	0	1	1	None	Always
4	Selecting the acceleration type	0	1	0	None	Always
5	Selecting the deceleration type	0	1	0	None	Always
6	Selecting of the cam profile	1	16	6	None	Always
7	Acceleration time during a trapezoidal move	1	9999	1000	msec	Always
8	Deceleration time during a trapezoidal move	1	9999	1000	msec	Always
9	Feeding Velocity	0	16000000	Motor dependent	Axis command unit/sec	Always
10	Jog Velocity	0	16000000	Motor dependent	Axis command unit/sec	Always
11	Over-travel search velocity during a homing move	1	16000000	Motor dependent	Axis command unit/sec	Always
12	Homing operation: Home sensor proximity signal search velocity	1	16000000	Motor dependent	Axis command unit/sec	Always
15	Homing operation: Origin position offset move feed velocity	1	16000000	Motor dependent	Axis command unit/sec	Always
16	Velocity override percentage 1	0	20000	10000	unit/sec	Always
17	Velocity override percentage 2	0	20000	10000	1/100 %	Always
20	Homing direction	0	1	0	None	Always
21	Enable/disable the over-travel signal under the homing mode	0	1	0	None	Always
27	Enabling the homing flag position error	0	1	1	None	Always
29	Offset distance from the Home position	-9999999	9999999	0	Axis command unit	Always
30	Homing complete operation command value	-9999999	9999999	0	Axis operation unit	Always
31	Operation width under testing mode	0	9999999	Motor dependent	Axis command unit	Always
32	Operation width under Auto-tuning	1	9999999	Motor dependent	Axis command unit	Always
33	Maximum acceleration/deceleration under Auto-tuning	100	9999	9999	msec	Always
34	Initializing the acceleration/deceleration time while under Auto-tuning	100	9999	1000	msec	Always
38	Servo stiffness settings	1	5	3	None	Always
39	Signal search direction	0	1	0	None	Always

Parameter No.	Parameter name	Minimum value	Maximum value	Initial value	Unit	Possible to change
41	Enabling the signal search mark signal	0	1	0	None	Always
42	Enabling the proximity signal during homing	0	1	0	None	Always
43	Enabling the (+) direction over-travel signal during the signal search	0	1	0	None	Always
44	Enabling the (-) direction over-travel signal during the signal search	0	1	0	None	Always
46	Signal search mark signal logic settings	0	1	0	None	Always
47	Logic for the proximity signal during homing	0	1	0	None	Always
48	Logic for the (+) direction over-travel signal during the signal search mode	0	1	0	None	Always
49	Logic for the (-) direction over-travel signal during the signal search mode	0	1	0	None	Always
50	Position control bandwidth	1	32	1	Hz	Always
51	Velocity control bandwidth	5	200	20	Hz	Always
53	Position integral limiting value	0	4999999	10000	None	Always
54	Position feed forward percentage	0	126	90	%	Always
55	Velocity feed forward percentage	0	126	100	%	Always
56	Acceleration feed forward gain	0	200	0	%	Always
58	Positioning settling width	0	9999999	5	Axis command unit	Always
59	Position deviation filter frequency	1	250	10	Hz	Always
60	Filter use when generating position settling signal	0	1	0	None	Always
65	Value causing an error detection in the (+) or CW direction	1	999999	999999	pulse	Always
66	Value causing an error detection in the (-) or CCW direction	-999999	-1	-999999	pulse	Always
68	Torque limit percentage	0	10000	10000	1/100 %	Always
69	Axis velocity monitoring gain (digital monitor)	0	8	0	None	Always
70	Analog monitor selection	0	5	4	None	Always
71	Axis positioning error monitoring gain (analog monitor)	0	8	0	None	Always
72	Test operation monitoring gain (analog monitor)	0	8	0	None	Always
73	Position monitoring gain (analog monitor)	0	14	0	None	Always
74	Position differential value monitoring gain (analog monitor)	0	7	0	None	Always
75	Velocity monitor selection (digital monitor)	0	1	0	None	Always
79	Move time during a cam profile selection	1	30000	2000	msec	Always

Parameter No.	Parameter name	Minimum value	Maximum value	Initial value	Unit	Possible to change
80	Acceleration time during a cam profile selection	1	9999	1000	msec	Always
81	Deceleration time during a cam profile selection	1	9999	1000	msec	Always
82	Enabling the Program step execution	0	1	0	None	Always
83	ABS in program/MDI operation	0	1	0	None	Always
84	Enabling the peak velocity during a cam profile move	0	1	0	None	Always
85	Enable the (+) direction soft limit error	0	1	0	None	Always
86	Enable the (-) direction soft limit error	0	1	0	None	Always
87	(+) direction soft limit settings	-999999999	999999999	0	Axis command unit	Always
88	(-) direction soft limit settings	-999999999	999999999	0	Axis command unit	Always
89	Brake turn OFF delay time upon Servo ON	0	2000	0	msec	Always
90	Advanced Brake turn ON before Servo OFF	0	2000	0	msec	Always
91	TBX_EMG Servo status	0	2	0	None	Always
92	Start-up program enable	0	1	0	None	Always
93	IFB_EMG Servo status	0	2	0	None	Always
100	M function enable in program and MDI operation	0	1	0	None	Always
101	M function enable during index operation	0	1	0	None	Always
102	Enabling the selection of serial communication type for the M function interface	0	1	0	None	Always
103	Optional stop enable	0	1	0	None	Always
104	ABS/INC setting during table and index operation	0	2	0	None	Always
105	Move direction option for rotation coordinates	0	4	0	None	Always
106	Settling wait enable	0	1	0	None	Always
108	Operation unit selection	0	2	0	None	Always
109	Index Type A divisions setting	-1	100	4	None	Always
110	Index Type B divisions setting	-1	0	0	None	Always
152	First order delay compensator setting	0	3	0	None	Always
153	Notch filter: Frequency 1 selection	50	1500	1500	Hz	Always
154	Notch filter: Frequency 2 selection	50	1500	1500	Hz	Always
155	Load inertial/load mass	0	200000	0	1/1000kgm <sup>2</sup> or 1/1000kg	Always

Parameter No.	Parameter name	Minimum value	Maximum value	Initial value	Unit	Possible to change
161	Area signal 0 ON	-999999999	999999999	0	Axis command unit	Always
162	Area signal 0 OFF	-999999999	999999999	0	Axis command unit	Always
163	Area signal 1 ON	-999999999	999999999	0	Axis command unit	Always
164	Area signal 1 OFF	-999999999	999999999	0	Axis command unit	Always
201	Selection of English/Japanese display	0	1	0	None	While in machine
202	Coordinate (+) direction setting	0	1	1	None	setting mode While in machine
208	Command unit selection	0	4	1	None	setting mode While in machine
209	Scaling data (command unit side)	1000	999999999	Motor dependent	Axis command unit	setting mode While in machine
210	Scaling data (pulse side)	1000	999999999	Motor dependent	pulse	setting mode While in machine
212	Straight line coordinate selection	0	1	Motor dependent	None	setting mode While in machine
213	Maximum velocity	1	16000000	Motor dependent	Axis command unit/sec	setting mode While in machine
215	IFB operation: Start signal processing speed selection	0	1	0	None	setting mode While in machine
216	Servo ON status upon power up during serial communication operations	0	1	1	None	setting mode While in machine
217	Jog move operation: Serial communication selection	0	1	0	None	setting mode While in machine
218	Enables error when over-load occurs	0	1	1	None	setting mode While in machine
219	Velocity feedback filter use	0	1	0	None	setting mode While in machine
220	Velocity feedback filter bandwidth	50	1000	1000	Hz	setting mode While in machine
221	Velocity command filter bandwidth	50	1000	1000	Hz	setting mode While in machine
222	Enables error when over-speed occurs	0	1	1	None	setting mode While in machine
224	Enables error when excessive position deviation occurs	0	1	1	None	setting mode While in machine
227	Over-speed error processing type	0	2	1	None	setting mode While in machine
228	Over-load error processing type	0	2	1	None	setting mode While in machine
229	Excessive position deviation error processing type	0	2	1	None	setting mode While in machine

**Parameter details**

STD1

**1 Enables the over-travel error function in the + direction****Always****Minimum value:** 0**Long:** +ホウコウハート OT エラ-ユウコウ**Maximum value:** 1

+HOT\_ErrorEnable

**Initial value:** 0**Short:** +HOT\_ErrEn**Unit:** None

+HOT\_ErrEn

Specify whether or not to enable an error when the over-travel signal in the + direction is detected while commanding to move the axis in the + direction.

0: Does not enable an error.

1: Enables an error.

**2 Enables the over-travel error function in the - direction****Always****Minimum value:** 0**Long:** -ホウコウハート OT エラ-ユウコウ**Maximum value:** 1

-HOT\_ErrorEnable

**Initial value:** 0**Short:** -HOT\_ErrEn**Unit:** None

-HOT\_ErrEn

Specify whether or not to enable an error when the over-travel signal in the - direction is detected while commanding to move the axis in the - direction.

0: Does not enable an error.

1: Enables an error.

**3 Selecting the type of cam profile move****Always****Minimum value:** 0**Long:** カムケイジ ヨウイト ウセンタク**Maximum value:** 1

CamMoveSel

**Initial value:** 1**Short:** カムイト ウ**Unit:** None

CamMoveSel

Specify the operation curve type during move operation that accompanies positioning (displacement amount is already known).

0: Trapezoidal motion profile

1: Cam profile motion profile

**4 Selecting the acceleration type****Always****Minimum value:** 0**Long:** カソクケイジ ヨウセンタク**Maximum value:** 1

AccProfeel

**Initial value:** 0**Short:** カソクケイジ ヨウ**Unit:** None

AccProfeel

Select the acceleration type during trapezoidal move.

0: Constant acceleration

1: S shaped

**5 Selecting the deceleration type****Always****Minimum value:** 0**Long:** ケソクケイジ ヨウセンタク**Maximum value:** 1

DecProfeel

**Initial value:** 0**Short:** ケソクケイジ ヨウ**Unit:** None

DecProfeel

Select the deceleration type during trapezoidal move.

0: Constant deceleration

1: S shaped

<b>6</b>	<b>Selection of the cam profile</b>	<b>Always</b>
<b>Minimum value:</b>	1	<b>Long:</b> カムケイシヨウセンタク
<b>Maximum value:</b>	16	CamProfeel
<b>Initial value:</b>	6	<b>Short:</b> カムケイシヨウ
<b>Unit:</b>	None	DecProfeel
Select the cam profile during cam profile move.		
1 to 8: Standard installed cam profile		
9 to 16: User registered cam profile		
<b>7</b>	<b>Acceleration time during a trapezoidal move</b>	<b>Always</b>
<b>Minimum value:</b>	1	<b>Long:</b> Tacc タイケイトウジ
<b>Maximum value:</b>	9999	TaccTrapezoid
<b>Initial value:</b>	1000	<b>Short:</b> Tacc タイケイ
<b>Unit:</b>	msec	TaccTrapez
Specify the acceleration time required for velocity change for the maximum velocity during trapezoidal move.		
<b>8</b>	<b>Deceleration time during a trapezoidal move</b>	<b>Always</b>
<b>Minimum value:</b>	1	<b>Long:</b> Tdec タイケイトウジ
<b>Maximum value:</b>	9999	TdecTrapezoid
<b>Initial value:</b>	1000	<b>Short:</b> Tdec タイケイ
<b>Unit:</b>	msec	TdecTrapez
Specify the deceleration time required for velocity change for the maximum velocity during trapezoidal move.		
<b>9</b>	<b>Feeding Velocity</b>	<b>Always</b>
<b>Minimum value:</b>	0	<b>Long:</b> オクリソクト
<b>Maximum value:</b>	16000000	FeedVelocity
<b>Initial value:</b>	Motor dependent	<b>Short:</b> オクリソクト
<b>Unit:</b>	Axis command unit/sec	FeedVel
Specify the feeding velocity.		
For trapezoidal move: Specify the feeding velocity.		
For cam move: Specify the feeding velocity (peak velocity).		
<b>10</b>	<b>Jog Velocity</b>	<b>Always</b>
<b>Minimum value:</b>	0	<b>Long:</b> ジョグオクリソクト
<b>Maximum value:</b>	16000000	JogVelocity
<b>Initial value:</b>	Motor dependent	<b>Short:</b> ジョグソクト
<b>Unit:</b>	Axis command unit/sec	JogVel
Specify the feeding velocity in jog mode.		
<b>11</b>	<b>Over-travel search velocity during a homing move</b>	<b>Always</b>
<b>Minimum value:</b>	1	<b>Long:</b> ORG-OT サーチオクリソクト
<b>Maximum value:</b>	16000000	ORG-OT_SearchVel
<b>Initial value:</b>	Motor dependent	<b>Short:</b> ORG-OT-VEL
<b>Unit:</b>	Axis command unit/sec	ORG-OT-Vel
Specify the velocity when executing over-travel signal search move in homing mode. This parameter is invalid if the over-travel signal search is not executed.		
<b>12</b>	<b>Homing operation: Home sensor proximity signal search velocity</b>	<b>Always</b>
<b>Minimum value:</b>	1	<b>Long:</b> ORG-キンボウサーチオクリソクト
<b>Maximum value:</b>	16000000	ORG-ORG_SearchVel
<b>Initial value:</b>	Motor dependent	<b>Short:</b> ORG-ORGVel
<b>Unit:</b>	Axis command unit/sec	ORG-ORGVel
Specify the velocity to search the home proximity signal in homing mode. This parameter is invalid if the origin proximity signal is not used.		

15 Homing operation: Origin position offset feed velocity		Always	
Minimum value:	1	Long:	ORG-オフセットイト <sup>ウ</sup> ウオクリソクト <sup>ウ</sup>
Maximum value:	16000000		ORG-OffsetVel
Initial value:	Motor dependent	Short:	ORG-OffVel
Unit:	Axis command unit/sec		ORG-OffVel

Specify the velocity when executing origin offset move in homing mode. This parameter is invalid if the origin offset is 0.

16 Velocity override percentage 1		Always	
Minimum value:	0	Long:	ソクト <sup>ウ</sup> オーバ <sup>ウ</sup> ライト <sup>ウ</sup> 1
Maximum value:	20000		VelOverride1
Initial value:	10000	Short:	V オーバ <sup>ウ</sup> ライト <sup>ウ</sup> 1
Unit:	1/100 %		VelOvrrid1

Specify override 1 for feeding velocity.

17 Velocity override percentage 2		Always	
Minimum value:	0	Long:	ソクト <sup>ウ</sup> オーバ <sup>ウ</sup> ライト <sup>ウ</sup> 2
Maximum value:	20000		VelOverride2
Initial value:	10000	Short:	V オーバ <sup>ウ</sup> ライト <sup>ウ</sup> 2
Unit:	1/100 %		VelOvrrid2

Specify override 2 for feeding velocity.

20 Homing direction		Always	
Minimum value:	0	Long:	ORG-ゲ <sup>ウ</sup> ンテンフッキホウコウ
Maximum value:	1		ORG-Direction
Initial value:	0	Short:	O-OrgDir
Unit:	None		O-OrgDir

Specify the homing direction (origin proximity signal search direction) in homing mode.

0: - direction

1: + direction

21 Enable/Disable the over-travel signal under the homing mode		Always	
Minimum value:	0	Long:	ORG-OT シンコ <sup>ウ</sup> ウシヨウ
Maximum value:	1		ORG-OT_SignalUse
Initial value:	0	Short:	O-OT_Use
Unit:	None		O-OT_Use

Specify whether or not to execute the over-travel signal search in homing mode.

0: Disables the over-travel signal search.

1: Enables the over-travel signal search.

25 Homing operation: Origin inside selection		Always	
Minimum value:	0	Long:	ORG-ゲ <sup>ウ</sup> ンテンウチカ <sup>ウ</sup> ワセンタク
Maximum value:	1		ORG-InsideSelect
Initial value:	1	Short:	O-Inside
Unit:	None		O-Inside

If the home position proximity signal is used in the home position mode, specify whether the Z signal inside the home position proximity signal is set to the origin or the Z signal outside the home position proximity signal is set to the origin. If the home position proximity signal is not used, this parameter is not valid.

0: The Z signal outside the home position proximity signal is set to the origin.

1: The Z signal inside the home position proximity signal is set to the origin.



**27 Enabling the homing flag position error****Always****Minimum value:** 0**Maximum value:** 1**Initial value:** 1**Unit:** None

**Long:** ORG-ト<sup>ク</sup> イチエラー-ユウコウ  
ORG-DogErrorEnable

**Short:** O-DogErrEn  
O-DogErrEn

When the homing mode is completed, an error or warning is generated when the relationship between the origin flag position and motor Z-phase position is as follows.

An error is generated if:

| Origin flag position - Z-phase position | > Z-phase gap x 0.45, or

| Origin flag position - Z-phase position | < Z-phase gap x 0.05

A warning is generated if:

| Origin flag position - Z-phase position | > Z-phase gap x 0.40, or

| Origin flag position - Z-phase position | < Z-phase gap x 0.10

**29 Offset distance from the Home position****Always****Minimum value:** -9999999**Maximum value:** 9999999**Initial value:** 0**Unit:** Axis command unit

**Long:** ORG-オフセットイ<sup>ト</sup> ヲリョウ  
ORG-Offset

**Short:** O-Offset  
O-Offset

Specify the origin offset amount in homing mode.

**30 Homing complete operation command value****Always****Minimum value:** -9999999**Maximum value:** 9999999**Initial value:** 0**Unit:** Axis command unit

**Long:** ORG-カンリョウコ<sup>ク</sup> ウンテンシレイ  
ORG-Pcmd[ unit]

**Short:** O-ウンテンシレイ  
ORG-Pcmd

Specify the operation command coordinate value after homing operation is completed.

**31 Operation width under testing mode****Always****Minimum value:** 0**Maximum value:** 9999999**Initial value:** Motor dependent**Unit:** Axis command unit

**Long:** TEST-ト<sup>ク</sup> ウサハバ<sup>ク</sup>  
TestWidth

**Short:** テスト<sup>ク</sup> ウサハバ<sup>ク</sup>  
TestWidth

Specify the operation width in test mode.

**32 Operation width under Auto-tuning****Always****Minimum value:** 1**Maximum value:** 9999999**Initial value:** Motor dependent**Unit:** Axis command unit

**Long:** A\_TUNE-ト<sup>ク</sup> ウサハバ<sup>ク</sup>  
A-TUNE-Width

**Short:** AT-ト<sup>ク</sup> ウサハバ<sup>ク</sup>  
AT-Width

Specify the operating range in auto-tuning mode.

**33 Maximum acceleration/deceleration under Auto-tuning****Always****Minimum value:** 10**Maximum value:** 9999**Initial value:** 9999**Unit:** msec

**Long:** A\_TUNE-Tacc サイ<sup>ク</sup> イ  
A-TUNE\_TaccMax

**Short:** AT-TaccMax  
AT\_TaccMax

Specify the maximum value of acceleration/deceleration time in auto-tuning mode.

<b>34</b>	<b>Initializing the acceleration/deceleration time while under Auto-tuning</b>	<b>Always</b>
-----------	--	---------------

<b>Minimum value:</b> 100	<b>Long:</b> A_TUNE-Tacc ショキチ
<b>Maximum value:</b> 9999	A-TUNE_Tacclni
<b>Initial value:</b> 1000	<b>Short:</b> AT-Tacclni
<b>Unit:</b> msec	AT_Tacclni

Specify the initial value of acceleration/deceleration time in auto-tuning mode.

<b>38</b>	<b>Servo stiffness settings</b>	<b>Always</b>
-----------	---------------------------------	---------------

<b>Minimum value:</b> 1	<b>Long:</b> サーボコウセイセツテイ
<b>Maximum value:</b> 5	ServoRigidity
<b>Initial value:</b> 3	<b>Short:</b> サーボコウセイ
<b>Unit:</b> None	ServoRigit

Specify the servo stiffness. (The larger the number is specified, the stronger the servo stiffness becomes. However, the motor vibrates more.)

- |                                 |                              |
|---------------------------------|------------------------------|
| 1: Velocity control width: 30Hz | Position control width: 7Hz  |
| 2: Velocity control width: 40Hz | Position control width: 10Hz |
| 3: Velocity control width: 50Hz | Position control width: 12Hz |
| 4: Velocity control width: 60Hz | Position control width: 15Hz |
| 5: Velocity control width: 70Hz | Position control width: 17Hz |

<b>39</b>	<b>Signal search direction</b>	<b>Always</b>
-----------	--------------------------------	---------------

<b>Minimum value:</b> 0	<b>Long:</b> SIG-ホウコウ
<b>Maximum value:</b> 1	SIG-Direction
<b>Initial value:</b> 0	<b>Short:</b> S-ホウコウ
<b>Unit:</b> None	S-Dir

Specify the search direction in signal search mode.

- 0: - direction
- 1: + direction

<b>41</b>	<b>Enabling the signal search mark signal</b>	<b>Always</b>
-----------	---	---------------

<b>Minimum value:</b> 0	<b>Long:</b> SIG-マークシグナルウエウコウ
<b>Maximum value:</b> 1	SIG-MarkEnable
<b>Initial value:</b> 0	<b>Short:</b> S-MrkEn
<b>Unit:</b> None	S-MrkEn

Specify whether or not to search the mark signal in signal search mode.

- 0: Disables the mark signal search.
- 1: Enables the mark signal search.

<b>42</b>	<b>Enabling the proximity signal during homing</b>	<b>Always</b>
-----------	--	---------------

<b>Minimum value:</b> 0	<b>Long:</b> SIG-ゲンテンキンホウウエウコウ
<b>Maximum value:</b> 1	SIG-OrgEnable
<b>Initial value:</b> 0	<b>Short:</b> S-OrgEn
<b>Unit:</b> None	S-OrgEn

Specify whether or not to search the origin proximity signal in signal search mode.

- 0: Disables the origin proximity signal search.
- 1: Enables the origin proximity signal search.

**43 Enabling the (+) direction over travel signal during the signal search** **Always**

---

<b>Minimum value:</b> 0	<b>Long:</b> SIG-+ホウコウ OT ユウコウ
<b>Maximum value:</b> 1	SIG-+OT_Enable
<b>Initial value:</b> 0	<b>Short:</b> S-OTEn+
<b>Unit:</b> None	S-OTEn+

Specify whether or not to search the (+) direction over-travel signal in signal search mode.

0: Disables the (+) direction over-travel signal search.

1: Enables the (+) direction over-travel signal search.

**44 Enabling the (-) direction over travel signal during the signal search** **Always**

---

<b>Minimum value:</b> 0	<b>Long:</b> SIG-ホウコウ OT ユウコウ
<b>Maximum value:</b> 1	SIG-OT_Enable
<b>Initial value:</b> 0	<b>Short:</b> S-OTEn-
<b>Unit:</b> None	S-OTEn-

Specify whether or not to search the (-) direction over-travel signal in signal search mode.

0: Disables the (-) direction over-travel signal search.

1: Enables the (-) direction over-travel signal search.

**46 Signal search mark signal logic settings** **Always**

---

<b>Minimum value:</b> 0	<b>Long:</b> SIG-マークシンゴウ ロンリ
<b>Maximum value:</b> 1	SIG-MarkLogic
<b>Initial value:</b> 0	<b>Short:</b> S-MrkLogic
<b>Unit:</b> None	S-MrkLogic

Specify the mark signal logic search in the signal search mode. This parameter is invalid if the mark signal search is not performed.

0: Mark signal OFF

1: Mark signal ON

**47 Logic for the proximity signal during homing** **Always**

---

<b>Minimum value:</b> 0	<b>Long:</b> SIG-キンホウシンゴウ ロンリ
<b>Maximum value:</b> 1	SIG-OrgLogic
<b>Initial value:</b> 0	<b>Short:</b> S-OrgLogic
<b>Unit:</b> None	S-OrgLogic

Specify the origin proximity signal logic in the signal search mode. This parameter is invalid if the origin proximity signal search is not performed.

0: Origin proximity signal OFF

1: Origin proximity signal ON

**48 Logic for the (+) direction over-travel signal during the signal search mode** **Always**

---

<b>Minimum value:</b> 0	<b>Long:</b> SIG-+ホウコウ OT ロンリ
<b>Maximum value:</b> 1	SIG-+OT_Logic
<b>Initial value:</b> 0	<b>Short:</b> S-OTLogic+
<b>Unit:</b> None	S-OTLogic+

Specify the + direction over-travel signal logic in the signal search mode. This parameter is invalid if the + direction over-travel signal search is not performed.

0: + direction over-travel signal OFF

1: + direction over-travel signal ON

**49 Logic for the (-) direction over-travel signal during the signal search mode** **Always**

<b>Minimum value:</b> 0	<b>Long:</b> SIG--ホウコウ OT ロンリ
<b>Maximum value:</b> 1	SIG--OT_Logic
<b>Initial value:</b> 0	<b>Short:</b> S-OTLogic-
<b>Unit:</b> None	S-OTLogic-

Specify the - direction over-travel signal logic in the signal search mode. This parameter is invalid if the - direction over-travel signal search is not performed.

- 0: - direction over-travel signal OFF
- 1: - direction over-travel signal ON

**50 Position control bandwidth** **Always**

<b>Minimum value:</b> 1	<b>Long:</b> イチセイキョタイキ
<b>Maximum value:</b> 32	PosControlFreq
<b>Initial value:</b> 1	<b>Short:</b> イチタイキ
<b>Unit:</b> Hz	PosFreq

Specify the position control bandwidth of the axis position control section. This parameter is set automatically by either executing auto-tuning operation or changing the "servo stiffness settings" parameter.

**51 Velocity control bandwidth** **Always**

<b>Minimum value:</b> 5	<b>Long:</b> ソクトセイキョタイキ
<b>Maximum value:</b> 200	VelControlFreq
<b>Initial value:</b> 20	<b>Short:</b> ソクトタイキ
<b>Unit:</b> Hz	VelFreq

Specify the control bandwidth of the velocity control section. This parameter is set automatically by either executing auto-tuning operation or changing the "servo stiffness settings" parameter.

**53 Position integral limiting value** **Always**

<b>Minimum value:</b> 0	<b>Long:</b> イチセキブンリミッタ
<b>Maximum value:</b> 4999999	PosIntegralLimit
<b>Initial value:</b> 10000	<b>Short:</b> セキブンリミッタ
<b>Unit:</b> None	PosIntLim

Specify the limiter value of the position error integrator in the axis position control section. Specify a smaller value when a wind-up condition occurs during axis operation. This parameter is set automatically by either executing auto-tuning operation or changing the "servo stiffness settings" parameter.

**54 Position feed forward percentage** **Always**

<b>Minimum value:</b> 0	<b>Long:</b> イチフィートフォワード_%
<b>Maximum value:</b> 126	Position_FF_%
<b>Initial value:</b> 90	<b>Short:</b> イチFF_%
<b>Unit:</b> %	Inch_FF%

Specify the position feed forward of the axis control section.

**55 Velocity feed forward percentage** **Always**

<b>Minimum value:</b> 0	<b>Long:</b> ソクトフィートフォワード_%
<b>Maximum value:</b> 126	Velocity_FF_%
<b>Initial value:</b> 100	<b>Short:</b> ソクトFF_%
<b>Unit:</b> %	Vel_FF%

Specify the velocity feed forward.

56	Acceleration feed forward gain	Always
<b>Minimum value:</b>	0	<b>Long:</b> カソクト <sup>+</sup> フィード <sup>+</sup> フォワード <sup>+</sup> _%
<b>Maximum value:</b>	200	Acceleration_FF_%
<b>Initial value:</b>	0	<b>Short:</b> カソクト <sup>+</sup> FF_%
<b>Unit:</b>	%	Acc_FF%

Specify the acceleration feed forward. This parameter calculates the internal gain based on the load inertia/load mass.

58	Positioning settling width	Always
<b>Minimum value:</b>	0	<b>Long:</b> イチセイテイハバ <sup>+</sup>
<b>Maximum value:</b>	9999999	CoinWidth
<b>Initial value:</b>	5	<b>Short:</b> イチセイテイハバ <sup>+</sup>
<b>Unit:</b>	Axis command unit	Coin_width

Specify the settling width to be used for position settling check and position settling wait in the axis position control section.

59	Position deviation filter frequency	Always
<b>Minimum value:</b>	1	<b>Long:</b> イチヘンサフィルタシュウハスウ
<b>Maximum value:</b>	250	PerrFilteFreq
<b>Initial value:</b>	10	<b>Short:</b> PerrFilFrq
<b>Unit:</b>	Hz	PerrFilFrq

Specify the position deviation filter frequency.

60	Filter use when generating position settling signal	Always
<b>Minimum value:</b>	0	<b>Long:</b> COIN セイセイシ <sup>+</sup> フィルタシヨウ
<b>Maximum value:</b>	1	FilterEn_atCOIN
<b>Initial value:</b>	0	<b>Short:</b> FilEn_COIN
<b>Unit:</b>	None	FilEn_COIN

Specify whether or not to use the position deviation filter when the position settling signal is generated.

0: Does not use.

1: Uses.

65	Value causing an error detection in the (+) or CW direction	Always
<b>Minimum value:</b>	1	<b>Long:</b> イチヘンサカタ <sup>+</sup> イケンシュツチ <sup>+</sup>
<b>Maximum value:</b>	999999	PosDevErrLimit+
<b>Initial value:</b>	999999	<b>Short:</b> イチヘンサリミット <sup>+</sup>
<b>Unit:</b>	pulse	PerrLim+

Specify the + direction detection value when an excessive position deviation error occurs.

66	Value causing an error detection in the (-) or CCW direction	Always
<b>Minimum value:</b>	-999999	<b>Long:</b> イチヘンサカタ <sup>-</sup> イケンシュツチ <sup>-</sup>
<b>Maximum value:</b>	-1	PosDevErrLimit-
<b>Initial value:</b>	-999999	<b>Short:</b> イチヘンサリミット <sup>-</sup>
<b>Unit:</b>	pulse	PerrLim-

Specify the - direction detection value when an excessive position deviation error occurs.

**68 Torque limit percentage****Always****Minimum value:** 0**Maximum value:** 10000**Initial value:** 10000**Unit:** 1/100 %**Long:** トルクリミットパーセンテージ

TorqLimit\_%

**Short:** トルクリミット%

TorqLimit%

This parameter can limit the torque or thrust.

**69 Axis velocity monitoring gain (digital monitor)****Always****Minimum value:** 0**Maximum value:** 8**Initial value:** 0**Unit:** None**Long:** ソフトモニタゲイン(Digital)

VelMonitorGain(Dig)

**Short:** VdigMon\_G

VdigMon\_G

Specify the axis velocity monitoring gain of the velocity monitor when controlling the digital velocity.

0: 6.55V / 32768 digits at digital detection velocity

1: 6.55V / 16384 digits

2: 6.55V / 8192 digits

3: 6.55V / 4096 digits

4: 6.55V / 2048 digits

5: 6.55V / 1024 digits

6: 6.55V / 512 digits

7: 6.55V / 256 digits

8: 6.55V / 128 digits

**70 Analog monitor selection****Always****Minimum value:** 0**Maximum value:** 5**Initial value:** 4**Unit:** None**Long:** アナログモニタセンタク

AnalogMonitorSelect

**Short:** A\_Mon センタク

A\_MonSel

Select the content to be output to the analog monitor.

0: Position deviation [pulse]

1: Test operation response [pulse]

2: Position command value [pulse]

3: Current position value [pulse]

4: Position command differential value (command velocity) [pps]

5: Current position differential value (current velocity) [pps]

**71 Axis positioning error monitoring gain (analog monitor)****Always****Minimum value:** 0**Maximum value:** 8**Initial value:** 0**Unit:** None**Long:** イチハンサモニタゲイン

PerrMonitorGain

**Short:** PerrMon\_G

PerrMon\_G

Specify the position deviation monitoring gain of the analog monitor.

0: 6.55V / 32768 pulses

1: 6.55V / 16384 pulses

2: 6.55V / 8192 pulses

3: 6.55V / 4096 pulses

4: 6.55V / 2048 pulses

5: 6.55V / 1024 pulses

6: 6.55V / 512 pulses

7: 6.55V / 256 pulses

8: 6.55V / 128 pulses

**72 Test operation monitoring gain (analog monitor)****Always**

**Minimum value:** 0  
**Maximum value:** 8  
**Initial value:** 0  
**Unit:** None

**Long:** テストウサモニタゲイン  
 TestMonitorGain  
**Short:** PerrMon\_G  
 PerrMon\_G

Specify the test operation response monitoring gain of the analog monitor.

0: 6.55V / 32768 pulses  
 1: 6.55V / 16384 pulses  
 2: 6.55V / 8192 pulses  
 3: 6.55V / 4096 pulses  
 4: 6.55V / 2048 pulses  
 5: 6.55V / 1024 pulses  
 6: 6.55V / 512 pulses  
 7: 6.55V / 256 pulses  
 8: 6.55V / 128 pulses

**73 Position monitoring gain (analog monitor)****Always**

**Minimum value:** 0  
**Maximum value:** 14  
**Initial value:** 0  
**Unit:** None

**Long:** 位置モニタゲイン  
 PosMonitorGain  
**Short:** PosMon\_G  
 PosMon\_G

Specify the position monitoring (position command value and current position value) gain of the analog monitor.

0: 6.55V / 4194304 pulses  
 1: 6.55V / 2097152 pulses  
 2: 6.55V / 1048576 pulses  
 3: 6.55V / 524288 pulses  
 4: 6.55V / 262144 pulses  
 5: 6.55V / 131072 pulses  
 6: 6.55V / 65536 pulses  
 7: 6.55V / 32768 pulses  
 8: 6.55V / 16384 pulses  
 9: 6.55V / 8192 pulses  
 10: 6.55V / 4096 pulses  
 11: 6.55V / 2048 pulses  
 12: 6.55V / 1024 pulses  
 13: 6.55V / 512 pulses  
 14: 6.55V / 256 pulses  
 15: 6.55V / 128 pulses

**74 Position differential value monitoring gain (analog monitor)****Always**

**Minimum value:** 0  
**Maximum value:** 7  
**Initial value:** 0  
**Unit:** None

**Long:** ソフトモニタゲイン  
 VelMonitorGain  
**Short:** VelMon\_G  
 VelMon\_G

Specify the position differential value monitoring (position command differential value and current position differential value) gain of the analog monitor.

0: 6.55V / 8192000 pulses  
 1: 6.55V / 4096000 pulses  
 2: 6.55V / 2048000 pulses  
 3: 6.55V / 1024000 pulses  
 4: 6.55V / 512000 pulses  
 5: 6.55V / 256000 pulses  
 6: 6.55V / 128000 pulses  
 7: 6.55V / 64000 pulses

**75 Velocity monitor selection (digital monitor)****Always**

**Minimum value:** 0  
**Maximum value:** 1  
**Initial value:** 0  
**Unit:** None

**Long:** ソフトモニタセンタク(Digital)  
 VelMonSel(Digital)  
**Short:** VelMonSelD  
 VelMonSelD

This parameter switches the velocity monitoring output content when controlling the digital velocity.

0: Velocity monitor  
 1: Velocity monitor AC

79 Move time during a cam profile selection		Always	
Minimum value:	1	Long:	カムイトウジイトウジカン
Maximum value:	30000		CamMoveTime
Initial value:	2000	Short:	カムイトウジカン
Unit:	msec		CamMoveTim

Specify the move time during cam profile move.

80 Acceleration time during a cam profile selection		Always	
Minimum value:	1	Long:	カムイトウジカソクジカン
Maximum value:	9999		TaccCam
Initial value:	1000	Short:	Tacc カム
Unit:	msec		TaccCam

Specify the acceleration time required for the 100% change of velocity override during cam profile move.

81 Deceleration time during a cam profile selection		Always	
Minimum value:	1	Long:	カムイトウジケンソクジカン
Maximum value:	9999		TdecCam
Initial value:	1000	Short:	Tdec カム
Unit:	msec		TdecCam

Specify the deceleration time required for the 100% change of velocity override during cam profile move.

82 Enabling the Program step execution		Always	
Minimum value:	0	Long:	プログラムステップジツコウ En
Maximum value:	1		ProgramStepEnable
Initial value:	0	Short:	PrgStepEn
Unit:	None		PrgStepEn

Specify whether or not to use step execution during program operation.  
 0: Normal execution  
 1: Step execution

83 ABS in program/MDI operation		Always	
Minimum value:	0	Long:	プログラム・MDI_ABS ユウコウ
Maximum value:	1		Prg・MDI_ABS_En
Initial value:	0	Short:	PrgMDI_ABS
Unit:	None		PrgMDI_ABS

Specify whether or not to use absolute move during program operation or MDI operation.  
 0: Incremental move  
 1: Absolute move

84 Enabling the peak velocity during a cam profile move		Always	
Minimum value:	0	Long:	カムピークソクドハメラータユウコウ
Maximum value:	1		CamPeakVelEnable
Initial value:	0	Short:	CamPeakEn
Unit:	None		CamPeakEn

Specify whether or not to operate by setting the peak velocity during cam profile move.  
 0: Operates using the move time during cam profile move operation.  
 1: Operates using the feeding velocity (peak velocity).



85	Enable the (+) direction soft limit error	Always
<b>Minimum value:</b>	0	<b>Long:</b> +ホウコウソフト OT エラ-ユウコウ
<b>Maximum value:</b>	1	+SOT_ErrorEnable
<b>Initial value:</b>	0	<b>Short:</b> +SOT_ErrEn
<b>Unit:</b>	None	+SOT_ErrEn

Specify whether or not to set the + direction soft limit error when the specified value exceeds the + direction soft limit command value.

- 0: Sets no error.
- 1: Sets an error.

86	Enable the (-) direction soft limit error	Always
<b>Minimum value:</b>	0	<b>Long:</b> -ホウコウソフト OT エラ-ユウコウ
<b>Maximum value:</b>	1	-SOT_ErrorEnable
<b>Initial value:</b>	0	<b>Short:</b> -SOT_ErrEn
<b>Unit:</b>	None	-SOT_ErrEn

Specify whether or not to set the - direction soft limit error when the specified value exceeds the - direction soft limit command value.

- 0: Sets no error.
- 1: Sets an error.

87	(+) direction soft limit settings	Always
<b>Minimum value:</b>	-999999999	<b>Long:</b> +ホウコウソフト OT リミット
<b>Maximum value:</b>	999999999	+SOT_Limit
<b>Initial value:</b>	0	<b>Short:</b> +SOT_Limit
<b>Unit:</b>	Axis command unit	+SOT_Limit

Specify the + direction soft limit value.

88	(-) direction soft limit settings	Always
<b>Minimum value:</b>	-999999999	<b>Long:</b> -ホウコウソフト OT リミット
<b>Maximum value:</b>	999999999	-SOT_Limit
<b>Initial value:</b>	0	<b>Short:</b> -SOT_Limit
<b>Unit:</b>	Axis command unit	-SOT_Limit

Specify the - direction soft limit value.

89	Brake turn OFF delay time upon Servo ON	Always
<b>Minimum value:</b>	0	<b>Long:</b> サーボ オンジ ブレーキオフチエン
<b>Maximum value:</b>	2000	TimeSrvOn_toBrkOff
<b>Initial value:</b>	0	<b>Short:</b> TimeBrkOff
<b>Unit:</b>	msec	TimeBrkOff

Specify the delay time from servo ON to brake OFF.

90	Advanced Brake turn ON before Servo OFF	Always
<b>Minimum value:</b>	0	<b>Long:</b> サーボ オフジ ブレーキオンチエン
<b>Maximum value:</b>	000	TimeBrkOn_toSrvOff
<b>Initial value:</b>	0	<b>Short:</b> TimeBrkOn
<b>Unit:</b>	msec	TimeBrkOn

Specify the advanced time for brake ON before servo OFF.

**91 TBX\_EMG Servo status****Always**

**Minimum value:** 0  
**Maximum value:** 2  
**Initial value:** 0  
**Unit:** None

**Long:** TBX\_EMG\_サーボシヨウタイ  
TbxEmgServoCondition  
**Short:** TbxEmg サーボ  
TbxEmgServ

Specify the servo status of the motor when EMG from TBX is executed.

- 0: Maintains the servo status after the axis operation stops.
- 1: Turns the servo OFF after the axis operation stops.
- 2: Stops the axis operation and immediately turns the servo OFF.

**92 Start-up program enable****Always**

**Minimum value:** 0  
**Maximum value:** 1  
**Initial value:** 0  
**Unit:** None

**Long:** スタートアッププログラムユウコウ  
StartUpProgramEnable  
**Short:** スタートProgEn  
StartPrgEn

Specify whether or not to execute the start-up program when program number 0 is registered.

- 0: Does not execute the start-up program.
- 1: Executes the start-up program.

**93 IFB\_EMG Servo status****Always**

**Minimum value:** 0  
**Maximum value:** 2  
**Initial value:** 0  
**Unit:** None

**Long:** IFB\_EMG\_サーボシヨウタイ  
IfbEmgServoCondition  
**Short:** IfbEmg サーボ  
IfbEmgServ

Specify the servo status of the motor when executing EMG from the interface board.

- 0: Maintains the servo status after the axis operation stops.
- 1: Turns the servo OFF after the axis operation stops.
- 2: Stops the axis operation and immediately turns the servo OFF.

**100 M function enable in program and MDI operation****Always**

**Minimum value:** 0  
**Maximum value:** 1  
**Initial value:** 0  
**Unit:** None

**Long:** M キノウユウコウ(PRG・MDI)  
M\_Enable(PRG・MDI)  
**Short:** PrgMDI\_MEn  
PrgMDI\_MEn

Specify whether or not to validate the M function during program and MDI operation.

- 0: Invalidates the M function.
- 1: Validates the M function.

**101 M function enable during index operation****Always**

**Minimum value:** 0  
**Maximum value:** 1  
**Initial value:** 0  
**Unit:** None

**Long:** M キノウユウコウ(INDEX)  
M\_Enable(Index)  
**Short:** Index\_M\_En  
Index\_M\_En

Specify whether or not to validate the M function during index operation.

- 0: Invalidates the M function.
- 1: Validates the M function.

**102 Enabling the selection of serial communication type for the M function interface****Always**

**Minimum value:** 0  
**Maximum value:** 1  
**Initial value:** 0  
**Unit:** None

**Long:** M インタフェースツウシンガワセンタク  
M\_Interface\_Sel\_RS  
**Short:** M\_Sel\_RS  
M\_Sel\_RS

Specify whether or not to set the M function interface destination at the serial communication side.

- 0: Sets the M function interface destination at the interface board side.
- 1: Sets the M function interface destination at the serial communication side.

**103 Optional stop enable****Always****Minimum value:** 0**Long:** オブショナルストップ ユカコウ**Maximum value:** 1

OptionalStopEn

**Initial value:** 0**Short:** OptStopEn**Unit:** None

OptStopEn

Specify whether or not to validate the optional stop function.

0: Invalidates the optional stop function.

1: Validates the optional stop function.

**104 ABS/INC setting during table and index operation****Always****Minimum value:** 0**Long:** Table · Index\_ABS/INC**Maximum value:** 2

Table · Index\_ABS/INC

**Initial value:** 0**Short:** TI\_ABS/INC**Unit:** None

TI\_ABS/INC

Specify the absolute move and incremental move during table reference and index operation.

[During table reference operation]

[During index operation]

0: Table data dependent

Incremental move

1: Table data dependent

Absolute move

2: Start-up option dependent

Start-up option dependent

**105 Move direction option for rotation coordinates****Always****Minimum value:** 0**Long:** カイテンサ<sup>テ</sup>ヒョウシ<sup>ン</sup>イド<sup>ウ</sup>ホウコウ**Maximum value:** 4

RotaryDirection

**Initial value:** 0**Short:** カイテンホウコウ**Unit:** None

RotDir

Specify the move direction setting when using the rotation coordinates.

[During G code operation]

[During table reference operation]

[During index operation]

0: Type 0

Type 0

Type 0

1: Type 1

Type 1

Type 1

2: Type 2

Type 2

Type 2

3: Type 0

Start-up option dependent

Start-up option dependent

4: Type 0

Table data dependent

Type 0

Type0: Short-cut move (not possible for multiple rotations)

Type1: Does not cross the rotation coordinate origin (not possible for multiple rotations)

Type2: Determines the direction by processing the target position using the current rotation coordinate origin as the reference (possible for multiple rotations).

**106 Settling wait enable****Always****Minimum value:** 0**Long:** セイテイマチユウコウ**Maximum value:** 1

CoinEnable

**Initial value:** 0**Short:** セイテイマチユウコウ**Unit:** None

CoinEnable

Specify whether or not to execute a settling wait for the move followed by positioning when the axis move operation is completed. For the move that is not followed by positioning, the settling wait is not executed regardless of this parameter setting. The settling wait is executed in homing mode regardless of this parameter setting.

0: Does not execute settling wait.

1: Executes settling wait.

**108 Operation unit selection****Always****Minimum value:** 0**Long:** ウンテンタンイセンタク**Maximum value:** 2

DriveCmdUnit

**Initial value:** 0**Short:** ウンテンタンイ**Unit:** None

DrvCmdUnit

Specify the axis operation unit.

0: Command unit

1: Index Type A

2: Index Type B

**109 Index Type A divisions setting****Always**

**Minimum value:** -1  
**Maximum value:** 100  
**Initial value:** 4  
**Unit:** None

**Long:** インデックスブランクツク\_A  
 IndexResolution\_A  
**Short:** IndexResA  
 IndexResA

Specify the number of divisions during index Type A operation.

- 1: Selects file A.
- 0: Selects file B.
- 1 to 100: Sets the number of divisions.

**110 Index Type B divisions setting****Always**

**Minimum value:** -1  
**Maximum value:** 0  
**Initial value:** 0  
**Unit:** None

**Long:** インデックスブランクツク\_B  
 IndexResolution\_B  
**Short:** IndexResB  
 IndexResB

Specify the number of divisions during index Type B operation.

- 1: Selects file A.
- 0: Selects file B.

**152 First order delay compensator setting****Always**

**Minimum value:** 0  
**Maximum value:** 3  
**Initial value:** 0  
**Unit:** None

**Long:** イチンデックレホシヨウ  
 CompFilterSel  
**Short:** イチンデックレ  
 FilterSel

Specify the first order delay compensator.

- 0: No first order delay compensator
- 1: 20Hz/80Hz
- 2: 30Hz/120Hz
- 3: 40Hz/160Hz

**153 Notch filter: Frequency 1 selection****Always**

**Minimum value:** 50  
**Maximum value:** 1500  
**Initial value:** 1500  
**Unit:** Hz

**Long:** ノッチフィルタシュウハスク 1  
 NotchFilterFreq1  
**Short:** ノッチシュウハスク 1  
 NotchFreq1

Specify the frequency of notch filter channel 1 for the driver equipped with the notch filter option. This parameter is not valid for the driver without the notch filter option.

**154 Notch filter: Frequency 2 selection****Always**

**Minimum value:** 50  
**Maximum value:** 1500  
**Initial value:** 1500  
**Unit:** Hz

**Long:** ノッチフィルタシュウハスク 2  
 NotchFilterFreq2  
**Short:** ノッチシュウハスク 2  
 NotchFreq2

Specify the frequency of notch filter channel 2 for the driver equipped with the notch filter option. This parameter is not valid for the driver without the notch filter option.

**155 Load inertia/load mass****Always**

**Minimum value:** 0  
**Maximum value:** 200000  
**Initial value:** 0  
**Unit:** 1/1000kgm<sup>2</sup> or 1/1000kg

**Long:** フカ\_J\_or\_M  
 Load\_J\_or\_M  
**Short:** フカ\_J\_or\_M  
 LoadJ\_or\_M

Specify the load inertia or load mass mounted on the motor. If an auto-tuning operation is executed, the measured value will be set automatically.

**161 Area signal 0 ON****Always****Minimum value:** -999999999**Long:** エリアシグナル0\_オン**Maximum value:** 999999999

AreaSignal0\_On

**Initial value:** 0**Short:** エリア Sig0\_オン**Unit:** Axis command unit

Area0\_On

Specify the position where area signal 0 turns ON. For the rotation coordinate operation, the value must be 0 or greater and less than the scaling data (command unit side) value.

**162 Area signal 0 OFF****Always****Minimum value:** -999999999**Long:** エリアシグナル0\_オフ**Maximum value:** 999999999

AreaSignal0\_Off

**Initial value:** 0**Short:** エリア Sig0\_オフ**Unit:** Axis command unit

Area0\_Off

Specify the position where area signal 0 turns OFF. For the rotation coordinate operation, the value must be 0 or greater and less than the scaling data (command unit side) value.

**163 Area signal 1 ON****Always****Minimum value:** -999999999**Long:** エリアシグナル1\_オン**Maximum value:** 999999999

AreaSignal1\_On

**Initial value:** 0**Short:** エリア Sig1\_オン**Unit:** Axis command unit

Area1\_On

Specify the position where area signal 1 turns ON. For the rotation coordinate operation, the value must be 0 or greater and less than the scaling data (command unit side) value.

**164 Area signal 1 OFF****Always****Minimum value:** -999999999**Long:** エリアシグナル1\_オフ**Maximum value:** 999999999

AreaSignal1\_Off

**Initial value:** 0**Short:** エリア Sig1\_オフ**Unit:** Axis command unit

Area1\_Off

Specify the position where area signal 1 turns OFF. For the rotation coordinate operation, the value must be 0 or greater and less than the scaling data (command unit side) value.

**201 Selection of English/Japanese display****While in machine setting mode****Minimum value:** 0**Long:** エイコヒョウシヤセンタク**Maximum value:** 1

EnglishDisplay

**Initial value:** 0**Short:** エイコヒョウシヤ**Unit:** None

EnglishDsp

Specify whether English display or Japanese display is used.

0: Japanese display

1: English display

**202 Coordinate (+) direction setting****While in machine setting mode****Minimum value:** 0**Long:** サヒョウケイセイホウコウ**Maximum value:** 1

AxisCoordinateDir

**Initial value:** 1**Short:** サヒョウホウコウ**Unit:** None

AxCoordDir

Specify the coordinate system direction.

0:

1:

**208 Axis command unit selection****While in machine setting mode**

**Minimum value:** 0  
**Maximum value:** 4  
**Initial value:** 1  
**Unit:** None

**Long:** シレイタンイセンタク  
 AxisCmdUnit  
**Short:** ジクシレイタンイ  
 AxisCmdUni

Specify the parameter unit related to the axis:

- 0: Pulse: Does not use the axis scaling data (command unit side) or axis scaling data (pulse side), but the axis motor pulse becomes the command unit.
- 1: Angle (DYNASERV): 360-degree angle is equivalent to the axis motor pulse specified with the axis scaling data (pulse side). The command unit is 1/1000 degrees.  
 Length (LINEARSERV): 1 m length is equivalent to the axis motor pulse specified with the axis scaling data (pulse side). The command unit is 1 microns.
- 2: Angle (DYNASERV): 360-degree angle is equivalent to the axis motor pulse specified with the axis scaling data (pulse side). The command unit is 1/100 degrees.  
 Length (LINEARSERV): 1 m length is equivalent to the axis motor pulse specified with the axis scaling data (pulse side). The command unit is 10 microns.
- 3: Scaling: The specified value set by the axis scaling data (command unit side) is equivalent to the axis motor pulse set by the axis scaling data (pulse side). The command unit is the unit of the numeric value entered as the axis scaling data (command unit side).
- 4: Angle (DYNASERV): 360-degree angle is equivalent to the axis motor pulse specified with the axis scaling data (pulse side). The command unit is 1/10000 degrees.  
 Length (LINEARSERV): 1 m length is equivalent to the axis motor pulse specified with the axis scaling data (pulse side). The command unit is 0.1 microns.

**209 Scaling data (command unit side)****While in machine setting mode**

**Minimum value:** 1000  
**Maximum value:** 99999999  
**Initial value:** Motor dependent  
**Unit:** Axis command unit

**Long:** スケーリング-タンイカワ  
 ScaleValue(AxisUnit)  
**Short:** ScaleUnit  
 ScaleUnit

Specify the data for converting the unit of the parameters related to the axis. Specify the value equivalent to the axis scaling data (pulse side). This parameter is used when scaling is selected by the "axis command unit selection." If the rotation coordinate system has been selected, this parameter is set to one rotation of the axis command unit coordinate system.

Example: Rotation: Circumference [micron]  
 Linear: Ball screw lead pitch [micron]

**210 Scaling data (pulse side)****While in machine setting mode**

**Minimum value:** 1000  
**Maximum value:** 99999999  
**Initial value:** Motor dependent  
**Unit:** pulse

**Long:** スケーリング-パルス  
 ScaleValue(AxisPIs)  
**Short:** ScalePulse  
 ScalePulse

Specify the data for converting the unit of the parameters related to the axis. Specify the value equivalent to the axis scaling data (command unit side). This parameter is used when angle and scaling are selected by "axis command unit selection." If the rotation coordinate system has been selected, this parameter is set to one rotation of the axis pulse coordinate system.

**212 Straight line coordinate selection****While in machine setting mode**

**Minimum value:** 0  
**Maximum value:** 1  
**Initial value:** Motor dependent  
**Unit:** None

**Long:** チョクセンサ<sup>レ</sup>ヒョウケイセンタク  
 LinearCoordinate  
**Short:** チョクセンサ<sup>レ</sup>ヒョウ  
 LinerCoord

Select the linear coordinate system.

- 0: Rotation coordinate system  
 1: linear coordinate system

---

**213 Axis maximum velocity** **While in machine setting mode**

---

<b>Minimum value:</b> 1	<b>Long:</b> サイタ <sup>°</sup> イソクト <sup>°</sup>
<b>Maximum value:</b> 16000000	Vmax
<b>Initial value:</b> Motor dependent	<b>Short:</b> サイタ <sup>°</sup> イソクト <sup>°</sup>
<b>Unit:</b> Axis command unit/sec	Vmax

Specify the maximum velocity during operation. The actual maximum velocity is determined by the smaller value of this parameter or the maximum velocity [axis command unit/sec] converted from the maximum velocity [rps, mps] determined by the motor and driver. This maximum velocity value is displayed on the monitor.

---

**215 IFB operation: Start signal processing speed selection** **While in machine setting mode**

---

<b>Minimum value:</b> 0	<b>Long:</b> IFB ウンテンカイシコウソクシヨリ
<b>Maximum value:</b> 1	IFB_ScanHighSpeed
<b>Initial value:</b> 0	<b>Short:</b> IFB コウソクシヨリ
<b>Unit:</b> None	IFB_High

Specify the start signal processing method for interface board operation.

- 0: Normal processing (10msec cyclic scan, auto delay read executed)
- 1: High speed processing (2msec cyclic scan, auto delay read not executed)

---

**216 Servo ON status upon power up during serial communication operations** **While in machine setting mode**

---

<b>Minimum value:</b> 0	<b>Long:</b> シリアルソクサジ <sup>°</sup> PWR サーボ <sup>°</sup> オン
<b>Maximum value:</b> 1	Serial_PWR_ServoOn
<b>Initial value:</b> 1	<b>Short:</b> PWRServoOn
<b>Unit:</b> None	PWRServoOn

Specify whether or not to set the servo ON status when the power is turned on during serial communication.

- 0: Servo OFF status
- 1: Servo ON status

---

**217 Jog move operation: Serial communication selection** **While in machine setting mode**

---

<b>Minimum value:</b> 0	<b>Long:</b> ショク <sup>°</sup> オクリツウシンカ <sup>°</sup> ワセンタク
<b>Maximum value:</b> 1	Jog_com_select_
<b>Initial value:</b> 0	<b>Short:</b> Jog_byRS
<b>Unit:</b> None	Jog_byRS

Select whether or not to perform jog feed operation at the serial communication side.

- 0: Interface board side
- 1: Serial communication side

---

**218 Enables error when over-load occurs** **While in machine setting mode**

---

<b>Minimum value:</b> 0	<b>Long:</b> オーバ <sup>°</sup> ロード <sup>°</sup> エラ <sup>°</sup> ユウコウ
<b>Maximum value:</b> 1	OverloadErrorEn
<b>Initial value:</b> 1	<b>Short:</b> OVL_ErrEn
<b>Unit:</b> None	OVL_ErrEn

Specify whether or not to process as an error when over-load occurs.

- 0: Does not process as an error.
- 1: Processes as an error.

---

**219 Velocity feedback filter use** **While in machine setting mode**

---

<b>Minimum value:</b> 0	<b>Long:</b> VfbFilter ショク
<b>Maximum value:</b> 1	UseVfbFilter
<b>Initial value:</b> 0	<b>Short:</b> VfbFil ショク
<b>Unit:</b> None	UseVfbFil

220 Velocity feedback filter bandwidth	While in machine setting mode
Minimum value: 50	Long: VfbFilter タイキ
Maximum value: 1000	VfbFilterFreq
Initial value: 1000	Short: VfbFilFreq
Unit: Hz	VfbFilFreq

221 Velocity command filter bandwidth	While in machine setting mode
Minimum value: 50	Long: VcmdFilter タイキ
Maximum value: 1000	VcmdFilterFreq
Initial value: 1000	Short: VcmdFilFrq
Unit: Hz	VcmdFilFrq

222 Enables error when over-speed occurs	While in machine setting mode
Minimum value: 0	Long: オーバースピードエラーユウコウ
Maximum value: 1	OverSpeedErrorEn
Initial value: 1	Short: OVS_ErrEn
Unit: None	OVS_ErrEn

Specify whether or not to process as an error when over-speed occurs.

- 0: Does not process as an error.
- 1: Processes as an error.

224 Enables error when excessive position deviation occurs	While in machine setting mode
Minimum value: 0	Long: イチヘンサカタ イエラーユウコウ
Maximum value: 1	OverPerrErrorEn
Initial value: 1	Short: OVPe_ErrEn
Unit: None	OVPe_ErrEn

Specify whether or not to process as an error when an excessive position deviation occurs.

- 0: Does not process as an error.
- 1: Processes as an error.

227 Over-speed error processing type	While in machine setting mode
Minimum value: 0	Long: オーバースピードエラーショリタイブ
Maximum value: 2	OverSpeedErrorType
Initial value: 1	Short: OVS_ErrTyp
Unit: None	OVS_ErrTyp

Specify the processing type when an over-speed error occurs.

- 0: Maintains the servo status after the axis operation stops.
- 1: Turns the servo OFF after the axis operation stops.
- 2: Stops the axis operation and immediately turns the servo OFF.

228 Over-load error processing type	While in machine setting mode
Minimum value: 0	Long: オーバロードエラーショリタイブ
Maximum value: 2	OverloadErrorType
Initial value: 1	Short: OVL_ErrTyp
Unit: None	OVL_ErrTyp

Specify the processing type when an over-load error occurs.

- 0: Maintains the servo status after the axis operation stops.
- 1: Turns the servo OFF after the axis operation stops.
- 2: Stops the axis operation and immediately turns the servo OFF.



**229 Excessive position deviation error processing type****While in machine setting mode**

**Minimum value:** 0  
**Maximum value:** 2  
**Initial value:** 1  
**Unit:** None

**Long:** イチヘンサカタ<sup>°</sup> イエラー<sup>°</sup> ショリタイプ<sup>°</sup>  
OverSpeedErrorType  
**Short:** OVPeErrTyp  
OVPeErrTyp

Specify the processing type when an excessive position deviation error occurs.

- 0: Maintains the servo status after the axis operation stops.
- 1: Turns the servo OFF after the axis operation stops.
- 2: Stops the axis operation and immediately turns the servo OFF.

**Monitor List**

Monitor No.	Monitor name	Unit
300	Currently under operation	None
301	Axis is under operation	None
302	Error status	None
303	Alarm status	None
304	Driver ready	None
305	Servo ready	None
306	Drive coordinate status	None
307	M function under operation	None
310	Display of program number under execution	None
311	Display of block number under execution in the program	None
312	Program nesting counter	None
313	Operation unit	None
314	Index Type A resolution current value	None
315	Index Type B resolution current value	None
316	Program auto-rewind enabled status	None
317	Completion of homing status display	None
318	Homing operation: The measured value	pulse
320	Pulse position command value	pulse
321	Pulse position current value	pulse
322	Pulse position deviation	pulse
323	Command unit command value	Axis command unit
324	Scaling data (command unit side)	Axis command unit
325	Scaling data (pulse side)	pulse
326	Axis under operation: Command value	Axis operation unit
328	Position settling status	None
329	Positioning status	None

Monitor No.	Monitor name	Unit
331	Area signal 0 status	None
332	Area signal 1 status	None
335	Interface ready	None
336	Operation hold status	None
337	Overload status	None
338	Zero signal status	None
339	Sensor group signal status	None
340	Zero signal fall edge side selection during homing operation	None
345	Error code (main)	None
346	Error code (sub)	None
347	Operation mode number	None
348	Multi-channel communication status	None
349	Multi-channel communication slave code	None
355	Monitor resolution	pulse/rev, pulse/m
356	Digital velocity sensitivity	digit/rps, digit/mps
357	Maximum velocity	Axis command unit/sec
358	Z-phase signal pulse interval	pulse/rev, pulse/m
360	Load ratio	x 1/100
361	Velocity ratio gain	x 1/100
362	Post-filter pulse position deviation	pulse
363	Velocity command value (digital)	1/16 digit
364	Post-filter velocity command value (digital)	1/16 digit
365	Present velocity value	1/16 digit
366	Present post-filter velocity value	1/16 digit
367	Velocity deviation (digital)	1/16 digit
368	Current command value (D/A)	digit
369	Present current value (A/D)	digit
370	Present command unit value	Axis command unit

Monitor No.	Monitor name	Unit
371	Command unit deviation	Axis command unit
372	Present velocity value DC	1/16 digit
387	Motor linear coordinate command value	pulse
388	Present motor linear coordinate value	pulse
390	Motor linear coordinate command differential value	pulse/ $\Delta T$
391	Present motor linear coordinate differential value	pulse/ $\Delta T$
392	Pre-filter current square duty	digit
393	Post-filter current square duty	digit
399	Time after power ON [msec]	msec

---

**300 Currently under operation****Unit:** None

Indicates that an operation is being performed.

---

**301 Axis is under operation****Unit:** None

Indicates that an axis operation is being performed.

---

**302 Error status****Unit:** None

Indicates the error status.

---

**303 Alarm status****Unit:** None

Indicates the alarm status.

---

**304 Driver ready****Unit:** None

Indicates that the driver is ready.

---

**305 Servo ready****Unit:** None

Indicates that the servo is ready.

---

**306 Drive coordinate status****Unit:** None

Indicates that the operation coordinate is ready to be used. If it cannot be used, an incremental move operation cannot be executed.

---

**307 M function under operation****Unit:** None

Indicates that the M function is being executed.

---

**310 Display of program number under execution**

---

**Unit:** None

Indicates the program number during execution or after execution.

---

**311 Display of block number under execution in the program**

---

**Unit:** None

Indicates the block number during execution or after execution.

---

**312 Program nesting counter**

---

**Unit:** None

Indicates the program nesting count during program execution.

---

**313 Operation unit**

---

**Unit:** None

Indicates the operation command unit.

0: Command unit

1: Index Type A

2: Index Type B

---

**314 Index Type A resolution current value**

---

**Unit:** None

Indicates the current value of the index Type A resolution.

---

**315 Index Type B resolution current value**

---

**Unit:** None

Indicates the current value of the index Type B resolution.

---

**316 Program auto-rewind enabled status**

---

**Unit:** None

Indicates the auto rewind enabled status in program operation.

---

**317 Completion of homing status display**

---

**Unit:** None

Indicates whether a homing operation has been completed after the power is turned on.

**318 Homing operation: The measured value**

---

**Unit:** pulse

Indicates the distance between the neighboring signal and origin that is measured during homing operation.

**320 Pulse position command value**

---

**Unit:** pulse

Displays the pulse position command value.

**321 Pulse position current value**

---

**Unit:** pulse

Displays the current pulse position value.

**322 Pulse position deviation**

---

**Unit:** pulse

Displays the pulse position deviation.

**323 Command unit command value**

---

**Unit:** Axis command unit

Displays the command unit command value.

**324 Scaling data (command unit side)**

---

**Unit:** Axis command unit

Displays the axis scaling data (command unit side) that is actually used.

**325 Scaling data (pulse side)**

---

**Unit:** pulse

Displays the axis scaling data (pulse side) that is actually used.

**326 Axis under operation: Command value**

---

**Unit:** Axis operation command

Displays the operation unit command value.

---

**328 Position settling status**

---

**Unit:** None

Indicates that the axis position deviation is within the specified range.

---

**329 Positioning status**

---

**Unit:** None

Indicates that the update of an axis position command value has stopped and the axis position deviation is within the specified range.

---

**331 Area signal 0 status**

---

**Unit:** None

Displays the area signal 0 status.

---

**332 Area signal 1 status**

---

**Unit:**

Displays the area signal 1 status.

---

**335 Interface ready**

---

**Unit:** None

Indicates that the PLC interface is ready.

---

**336 Operation hold status**

---

**Unit:** None

Indicates that the operation status is locked.

---

**337 Overload status**

---

**Unit:** None

Displays the overload status.

---

**338 Zero signal status**

---

**Unit:** None

Displays the zero signal status.



---

**339 Sensor group signal status**

---

**Unit:** None

Displays the sensor group signal status. Each bit in binary notation corresponds as follows:

bit0: (Reserved)

bit1: (Reserved)

bit2: (Reserved)

bit3: (Reserved)

bit4: ORG Origin neighboring signal

bit5: OTU + direction hardware over-travel signal

bit6: OTD - direction hardware over-travel signal

bit7: (Reserved)

---

**340 Zero signal fall edge side selection during homing operation**

---

**Unit:** None

Displays whether the fall edge side of the zero signal is selected as an edge during homing operation.

0: Selects the rising edge.

1: Selects the falling edge.

---

**345 Error code (main)**

---

**Unit:** None

Displays the error code (main code).

---

**346 Error code (sub)**

---

**Unit:** None

Displays the error code (subcode).

---

**347 Operation mode number**

---

**Unit:** None

Indicates the operation mode number during or after operation.

---

**348 Multi-channel communication status**

---

**Unit:** None

Indicates that the multi-channel communication status has been set.

0: Single channel communication status

1: multi-channel communication status

---

**349 Multi-channel communication slave code**

---

**Unit:** None

Indicates the slave station (self-station) code in multi-channel communication.

---

**355 Monitor resolution**

---

**Unit:** pulse/rev, pulse/m

Displays the monitor resolution.

---

**356 Digital velocity sensitivity**

---

**Unit:** digit/rps, digit/mps

Displays the digital velocity sensitivity.

---

**357 Maximum velocity**

---

**Unit:** Axis command unit/sec

This parameter is defined by the smaller value of the maximum velocity [axis command unit/sec] set by the user and the maximum velocity [axis command unit/sec] converted from the maximum velocity [rps, mps] set by the motor and driver. The position command velocity is restricted by this value. In addition, for trapezoidal (constant acceleration/deceleration) move, the inclination of acceleration/deceleration is calculated from the acceleration/deceleration time parameter, feed velocity parameter in operation mode, and this parameter value.

---

**358 Z-phase signal pulse interval**

---

**Unit:** pulse/rev, pulse/m

Displays the Z-phase signal pulse interval.

---

**360 Load ratio**

---

**Unit:** x 1/100

Displays the load inertia/self-inertia and load mass/self-mass.

---

**361 Velocity ratio gain**

---

**Unit:** x 1/100

Displays the velocity loop ratio gain.

---

**362 Post-filter pulse position deviation**

---

**Unit:** pulse

Displays the post-filter pulse position deviation.

---

**363 Velocity command value (digital)**

---

**Unit:** 1/16 digit

Displays the velocity command value when controlling the digital velocity. (1msec sample)

---

**364 Post-filter velocity command value (digital)**

---

**Unit:** 1/16 digit

Displays the post-filter velocity command value when controlling the digital velocity. (1msec sample)

---

**365 Present velocity current value**

---

**Unit:** 1/16 digit

Displays the present velocity value. (1msec sample)

---

**366 Present post-filter velocity value**

---

**Unit:** 1/16 digit

Displays the present post-filter velocity value. (1msec sample)

---

**367 Velocity deviation (digital)**

---

**Unit:** 1/16 digit

Displays the velocity deviation. (1msec sample)

---

**368 Current command value (D/A)**

---

**Unit:** digit

Displays the current command value D/A output value. The conversion rate is as follows:

1 digit = 0.0036%

27853 digits: +100%

0 digits: 0%

-27853 digits: -100%

---

**369 Present current value (A/D)**

---

**Unit:** digit

Displays the A/D input value of the present current command value.(1msec sample) The conversion rate is as follows:

1 digit = 0.0036%

27840digits: +100%

0 digits: 0%

-27840 digits: -100%

---

**370 Present command unit value**

---

**Unit:** Axis command unit

Displays the present command unit value.

---

**371 Command unit deviation**

---

**Unit:** Axis command unit

Displays the command unit deviation.

---

**372 Present velocity value DC**

---

**Unit:** 1/16 digit

Displays the present velocity value DC. (10msec sample)

---

**387 Motor linear coordinate command value**

---

**Unit:** pulse

Displays the motor linear coordinate command value.

---

**388 Present motor linear coordinate value**

---

**Unit:** pulse

Displays the present eccentricity-compensated motor linear coordinate value.

---

**390 Motor linear coordinate command differential value**

---

**Unit:** pulse/ $\Delta T$

Displays the differential value of the motor linear coordinate command value. (2msec sample)

---

**391 Present motor linear coordinate differential value**

---

**Unit:** pulse/ $\Delta T$

Displays the differential value of the present motor linear coordinate value. (2msec sample)

---

**392 Pre-filter current square duty**

---

**Unit:** digit

Displays the pre-filter current square duty (decimal point 15 bits).

---

**393 Post-filter current square duty**

---

**Unit:** digit

Displays the post-filter current square duty (decimal point 15 bits)

---

**399 Time after power ON [msec]**

---

**Unit:** msec

Indicates the time after the power has been turned on.

## About Errors/Alarms

### Error/Alarm Types

[KIND_POR]	Startup error	Error that cannot be set to CPU ready (unrecoverable) Unrecoverable error	
[KIND_SYS]	System error		
[KIND_RGR]	Always error		
[KIND_SRV]	Servo error		
[KIND_ERR]	Error		
[KIND_ERRALM1]	Error/operation alarm		Error or operation warning depending on the operation status
[KIND_ERRALM2]	Error/operation alarm		Error or operation warning depending on the operation status
[KIND_ARM]	Operation alarm		
[KIND_ELS]	Others		

### Error/Alarm Countermeasures

		Recovery	Servo	
[TYPE-POR]	Do not start up	Not possible	OFF	-
[TYPE-SRV]	Servo OFF	Possible	OFF	-
[TYPE-E1]	Stop deceleration/servo OFF	Possible	OFF	Stop deceleration
[TYPE-E2]	Stop deceleration	Possible	-	Stop deceleration
[TYPE-ELS]	Others	-	-	-

Each error code consists of a main code and a subcode.

## Error/Alarm List

STD1

Error No.	Name	Type	Measures
1	Memory error	[KIND_POR] Start-up error	[TYPE_POR] Do not start up.
2	Interface board error	[KIND_POR] Start-up error	[TYPE_POR] Do not start up.
3	Battery alarm	[KIND_ELS] Others	[TYPE_ELS] Others
4	Watchdog error	[KIND_SYS] System error	[TYPE_ELS] Others
5	Kernel error	[KIND_SYS] System error	[TYPE_ELS] Others
10	Data sum error	[KIND_POR] Start-up error	[TYPE_POR] Do not start up.
11	Data error	[KIND_POR] Start-up error	[TYPE_POR] Do not start up.
15	Encoder error	[KIND_SYS] System error	[TYPE_SRV] Servo OFF
16	Coordinate error A	[KIND_SYS] System error	[TYPE_SRV] Servo OFF
17	Coordinate error B	[KIND_ERRALM2] Error/operation alarm	[TYPE_E2] Stop deceleration.
19	Slave drive error	[KIND_RGR] Always error	[TYPE_SRV] Servo OFF
20	Power module error	[KIND_RGR] Always error	[TYPE_SRV] Servo OFF
21	AC power error	[KIND_RGR] Always error	[TYPE_SRV] Servo OFF
22	Over load	[KIND_RGR] Always error	[TYPE_ELS] Others
23	Excessive position deviation	[KIND_SRV] Servo error	[TYPE_ELS] Others
24	Over speed	[KIND_RGR] Always error	[TYPE_ELS] Others
30	Servo not ready	[KIND_ERR] error	[TYPE_E2] Stop deceleration.
31	Excessive position command differential value	[KIND_ERR] error	[TYPE_E2] Stop deceleration.
42	+ direction hardware over-travel	[KIND_ERR] error	[TYPE_E2] Stop deceleration.
43	- direction hardware over-travel	[KIND_ERR] error	[TYPE_E2] Stop deceleration.
44	+ direction software over-travel	[KIND_ERR] error	[TYPE_E2] Stop deceleration.
45	- direction software over-travel	[KIND_ERR] error	[TYPE_E2] Stop deceleration.
46	Emergency stop	[KIND_ERR] error	[TYPE_E2] Stop deceleration.
49	Homing error	[KIND_ERRALM1] Error/operation alarm	[TYPE_E2] Stop deceleration.
50	Cannot execute	[KIND_ERRALM2] Error/operation alarm	[TYPE_E2] Stop deceleration.
51	Data not ready	[KIND_ERRALM2] Error/operation alarm	[TYPE_E2] Stop deceleration.
52	Timeout	[KIND_ERRALM1] Error/operation alarm	[TYPE_E2] Stop deceleration.
53	Cannot calculate	[KIND_ERRALM1] Error/operation alarm	[TYPE_E2] Stop deceleration.
56	M interface error	[KIND_ERRALM2] Error/operation alarm	[TYPE_E2] Stop deceleration.
60	Cannot interpret	[KIND_ERRALM2] Error/operation alarm	[TYPE_E2] Stop deceleration.
61	Command format error	[KIND_ERRALM2] Error/operation alarm	[TYPE_E2] Stop deceleration.
62	Data is out of range	[KIND_ERRALM2] Error/operation alarm	[TYPE_E2] Stop deceleration.
63	Operation error	[KIND_ALM] Operation alarm	[TYPE_E2] Stop deceleration.
65	Illegal parameter and monitor number	[KIND_ERRALM2] Error/operation alarm	[TYPE_E2] Stop deceleration.
66	Illegal device	[KIND_ALM] Operation alarm	[TYPE_E2] Stop deceleration.
67	Write protected	[KIND_ERRALM2] Error/operation alarm	[TYPE_E2] Stop deceleration.
80	No such command	[KIND_ALM] Operation alarm	[TYPE_E2] Stop deceleration.
81	Not registered	[KIND_ALM] Operation alarm	[TYPE_E2] Stop deceleration.
82	Out of memory	[KIND_ALM] Operation alarm	[TYPE_E2] Stop deceleration.
85	Device conflict	[KIND_ALM] Operation alarm	[TYPE_E2] Stop deceleration.

## Error/Alarm Details

### Error number 1 Memory error

		<b>Long:</b> メモリエラー MemoryError
Error type:	[KIND_POR] Start-up error	<b>Short:</b> メモリエラー MemoryErr
Measures:	[TYPE_POR] Do not start up.	
Main cause:	An error is detected during memory check when the power is turned on. [Subcode] 1: CPU built-in ROM sum error 2: RAM error 3: Flash ROM sum error	
Action to take:	Contact us.	

### Error number 2 Interface board error

		<b>Long:</b> インタフェースボードエラー InterfaceBoardError
Error type:	[KIND_POR] Start-up error	<b>Short:</b> IFB エラー IFB_Err
Measures:	[TYPE_POR] Do not start up.	
Main cause:	Failed to initialize the interface board.	
Action to take:	Contact us.	

### Error number 3 Battery alarm

		<b>Long:</b> バッテリアラーム BatteryAlarm
Error type:	[KIND_ELS] Others	<b>Short:</b> バッテリアラーム BatteryAlm
Measures:	[TYPE_ELS] Others	
Main cause:	Battery voltage for memory backup is low.	
Action to take:	Replace with a new lithium battery.	

### Error number 4 Watchdog error

		<b>Long:</b> ウォッチドッグエラー WatchdogError
Error type:	[KIND_SYS] System error	<b>Short:</b> ウォッチドッグ Watchdog
Measures:	[TYPE_ELS] Others	
Main cause:	A watchdog timer error occurred. The driver will be set in the reset status.	
Action to take:	Contact us.	

---

**Error number                    5           Kernel error**

---

**Long:**    カーネルエラー  
          KernelError

**Short:**    カーネルエラー  
          KernelErr

Error type:    [KIND\_SYS] System error  
Measures:    [TYPE\_ELS] Others  
Main cause:    An error that should have not occurred in driver software has occurred.  
                  [Subcode]  
                  1: Axis operation handshake error  
                  2: System program error

Action to take:    Contact us.

---

**Error number                    10           Data sum error**

---

**Long:**    データサムエラー  
          DataSumError

**Short:**    データサムエラー  
          DataSumErr

Error type:    [KIND\_POR] Start-up error  
Measures:    [TYPE\_POR] Do not start up.  
Main cause:    Destroyed data was detected during data check when the power was turned on.  
                  [Subcode]  
                  1: Parameter file  
                  2: Parts data file  
                  3: Program file  
                  4: Index correction file  
                  5: I/O logic setting file  
                  6: Index file Type B  
                  7: Absolute accuracy compensation file

Action to take:    Perform the Reset All operation, and download all backup data.

---

**Error number                    11           Data error**

---

**Long:**    データエラー  
          DataError

**Short:**    データエラー  
          DataError

Error type:    [KIND\_POR] Start-up error  
Measures:    [TYPE\_POR] Do not start up.  
Main cause:    Data that cannot be processed was detected when the power was turned on:  
                  [Subcode]  
                  1: Basic data and adjustment data problem  
                  2: Servo constant problem

Action to take:    Contact us.

---

**Error number                    15           Encoder error**

---

**Long:**    エンコーダエラー  
          EncoderError

**Short:**    エンコーダエラー  
          EncoderErr

Error type:    [KIND\_SYS] System error  
Measures:    [TYPE\_SRV] Servo OFF  
Main cause:    An encoder and revolver signal problem was detected.  
                  [Subcode]  
                  1: No SIG0 signal edge  
                  2: No SIG1 signal edge  
                  3: SIG0 signal cycle problem  
                  4: SIG1 signal cycle problem

Action to take:    Contact us.



---

**Error number**                    **16**    **Coordinate error A**

---

**Long:**    ザ°ヒヨウケイジ°ヨウ A  
            CoordinateErrorA

**Short:**    ザ°ヒヨウエラー A  
            CoordiErrA

Error type:    [KIND\_SYS] System error

Measures:    [TYPE\_SRV] Servo OFF

Main cause:    An error occurred during coordinate processing.  
                  [Subcode]  
                  1: Eccentricity compensation computation problem  
                  2: Conversion problem from the command unit to pulses

Action to take:

---

**Error number**                    **17**    **Coordinate error B**

---

**Long:**    ザ°ヒヨウケイジ°ヨウ B  
            CoordinateErrorB

**Short:**    ザ°ヒヨウエラー B  
            CoordiErrB

Error type:    [KIND\_ERRALM2] Error/operation alarm

Measures:    [TYPE\_E2] Stop deceleration.

Main cause:    An error occurred during coordinate processing.  
                  [Subcode]  
                  1: Executed the process that was prohibited in the coordinate non-settling status.  
                  2: Out of the command coordinate area  
                  3: Executed a process using the setting that is prohibited.

Action to take:

---

**Error number**                    **19**    **Slave drive error**

---

**Long:**    スレーブドライブ°エラー  
            SlaveDriveError

**Short:**    スレーブ°エラー  
            SlvDrvErr

Error type:    [KIND\_RGR] Always error

Measures:    [TYPE\_SRV] Servo OFF

Main cause:    A tandem slave driver error occurred.

Action to take: Check the error code of the tandem slave driver, and take measures against the tandem slave driver problem. This error occurs only if the driver is the tandem master driver.

---

**Error number**                    **20**    **Power module error**

---

**Long:**    ハ°ワ-モジ°ユ-ルエラー  
            PowerModuleError

**Short:**    PwrMdl エラー  
            PwrMdlErr

Error type:    [KIND\_RGR] Always error

Measures:    [TYPE\_SRV] Servo OFF

Main cause:    A power module error in the driver was detected.  
                  [subcode]  
                  1: Over-voltage (over-voltage of main power supply)  
                  2: Over-current (over-current detected, 1 PM fault)

Action to take:

---

**Error number**                    **21**    **AC power error**

---

**Long:**    シュテ<sup>ン</sup>ゲ<sup>ン</sup>イジ<sup>ョウ</sup>カ  
            AC\_PowerError

**Short:**   シュテ<sup>ン</sup>ゲ<sup>ン</sup>  
            AC\_PwrErr

Error type:    [KIND\_RGR] Always error  
Measures:     [TYPE\_SRV] Servo OFF  
Main cause:    Either the main power supply is not input or the input voltage has not reached the rating level.  
Action to take: Verify the main power supply.

---

**Error number**                    **22**    **Over load**

---

**Long:**    オーバ<sup>ー</sup>ロ<sup>ー</sup>ド<sup>ト</sup>  
            Overload

**Short:**    オーバ<sup>ー</sup>ロ<sup>ー</sup>ド<sup>ト</sup>  
            Overload

Error type:    [KIND\_RGR] Always error  
Measures:     [TYPE\_ELS] Others  
Main cause:    The motor use is overloaded.  
                  [Subcode]  
                  1: The motor is overheated.  
                  2: The power module heat sink is overheated.

Action to take:

---

**Error number**                    **23**    **Excessive position deviation**

---

**Long:**    イチヘンサカダ<sup>イ</sup>  
            OverPerr

**Short:**    イチヘンサカダ<sup>イ</sup>  
            OverPerr

Error type:    [KIND\_SRV] Servo error  
Measures:     [TYPE\_ELS] Others  
Main cause:    The position deviation was greater than the tolerance.  
Action to take: Perform the servo adjustment again. If an error still occurs, extend the tolerance.

---

**Error number**                    **24**    **Over speed**

---

**Long:**    ソクト<sup>カ</sup>ダ<sup>イ</sup>  
            OverSpeed

**Short:**    ソクト<sup>カ</sup>ダ<sup>イ</sup>  
            OverSpeed

Error type:    [KIND\_RGR] Always error  
Measures:     [TYPE\_ELS] Others  
Main cause:    The velocity was higher than the maximum velocity.  
Action to take:

---

**Error number**                    **30**    **Servo not ready**

---

**Long:**    サーボ<sup>ノ</sup>ットレ<sup>テ</sup>イ  
            ServoNotReady

**Short:**    サーボ<sup>ノ</sup>ットレ<sup>テ</sup>  
            SrvNotRdy

Error type:    [KIND\_ERR] error  
Measures:     [TYPE\_E2] Stop deceleration.  
Main cause:    The servo was not ready for the process that requires the servo to be ON.  
Action to take: Perform an error reset operation, turn ON the servo, and execute again.

---

**Error number                    31    Excessive position command differential value**

---

**Long:**    イチシレイサブ<sup>ン</sup>チカダ<sup>イ</sup>  
          OverDiffPcmd

**Short:**    イチシレイサブ<sup>ン</sup>  
          OverDPcmd

Error type:    [KIND\_ERR] error

Measures:    [TYPE\_E2] Stop deceleration.

Main cause:    The position command with the variation rate that was greater than the maximum velocity was given.

Action to take:    The velocity override may be 100% or more. Verify it.

---

**Error number                    42    + direction hardware over-travel**

---

**Long:**    +ホウコウハート<sup>°</sup>オーハ<sup>°</sup>トラベ<sup>ル</sup>  
          Hard\_OT+\_direction

**Short:**    +ホウコウ H\_OT  
          +\_Hard\_OT

Error type:    [KIND\_ERR] error

Measures:    [TYPE\_E2] Stop deceleration.

Main cause:    The + direction hardware over-travel signal was detected while moving to the + direction.

Action to take:    Perform an error reset operation, then move to the - direction.

---

**Error number                    43    - direction hardware over-travel**

---

**Long:**    -ホウコウハート<sup>°</sup>オーハ<sup>°</sup>トラベ<sup>ル</sup>  
          Hard\_OT-\_direction

**Short:**    -ホウコウ H\_OT  
          -\_Hard\_OT

Error type:    [KIND\_ERR] error

Measures:    [TYPE\_E2] Stop deceleration.

Main cause:    The - direction hardware over-travel signal was detected while moving to the - direction.

Action to take:    Perform an error reset operation, then move to the + direction.

---

**Error number                    44    + direction software over-travel**

---

**Long:**    +ホウコウソフトオーハ<sup>°</sup>トラベ<sup>ル</sup>  
          Soft\_OT+\_direction

**Short:**    +ホウコウ S\_OT  
          +\_Soft\_OT

Error type:    [KIND\_ERR] error

Measures:    TYPE\_E2] Stop deceleration.

Main cause:    Attempted to move to outside of the + direction area via positioning move, but the command unit command value was outside of the + direction area.

Action to take:    Perform an error reset operation. If the command unit command value is outside of the area, move to the - direction. This error occurs only for the linear coordinates.

---

**Error number**                    **45**        **- direction software over-travel**

---

**Long:**    -ホウコウソフトオーバーtravel  
Soft\_OT\_-\_direction

**Short:**   -ホウコウ S\_OT  
              \_-\_Soft\_OT

**Error type:**    [KIND\_ERR] error

**Measures:**    TYPE\_E2] Stop deceleration.

**Main cause:**    Attempted to move to outside of the - direction area via positioning move, but the command unit command value was outside of the - direction area.

**Action to take:** Perform an error reset operation. If the command unit command value is outside of the area, move to the + direction. This error occurs only for the linear coordinates.

---

**Error number**                    **46**        **Emergency stop**

---

**Long:**    ヒジ ヨウテイシ  
EmergencyStop

**Short:**    ヒジ ヨウテイシ  
EMG\_Stop

**Error type:**    [KIND\_ERR] error

**Measures:**    TYPE\_E2] Stop deceleration.

**Main cause:**    An emergency stop instruction was entered.

**Action to take:** Reset the error.

---

**Error number**                    **49**        **Homing error**

---

**Long:**    ケンテンフッキイジ ヨウ  
OriginError

**Short:**    ケンテンイジ ヨウ  
OriginErr

**Error type:**    [KIND\_ERRALM1] Error/operation alarm

**Measures:**    [TYPE\_E2] Stop deceleration.

**Main cause:**    An error occurred during homing operation.  
                  [Subcode]  
                  1: Locating fixture position problem

**Action to take:** -

---

**Error number**                    **50**        **Cannot execute**

---

**Long:**    ジ ッコウフカ  
CantExec

**Short:**    ジ ッコウフカ  
CantExec

**Error type:**    [KIND\_ERRALM2] Error/operation alarm

**Measures:**    [TYPE\_E2] Stop deceleration.

**Main cause:**    Cannot execute.  
                  [Subcode]  
                  1: Prohibited command  
                  2: Execution in progress  
                  3: Error status  
                  4: Data is being used.  
                  5: Invalid data  
                  6: Access timing  
                  7: Driver mode  
                  8: Invalid program file  
                  9: Nesting overflow

**Action to take:**

---

**Error number**                    **51**    **Data not ready**

---

Error type:        [KIND\_ERRALM2] Error/operation alarm  
Measures:        [TYPE\_E2] Stop deceleration.  
Main cause:       Data is not ready.

- [Subcode]  
2: Part data  
3: Program file  
4: Index A correction file  
6: Index B file

Action to take:

**Long:**    データノットレディ  
          DataNotReady  
**Short:**    データノットレディ  
          DataNotRdy

---

**Error number**                    **52**    **Timeout**

---

Error type:        [KIND\_ERRALM1] Error/operation alarm  
Measures:        [TYPE\_E2] Stop deceleration.  
Main cause:       A timeout occurred during internal processing.  
Action to take:    Contact us.

**Long:**    タイムアウト  
          TimeOut  
**Short:**    タイムアウト  
          TimeOut

---

**Error number**                    **53**    **Cannot calculate**

---

Error type:        [KIND\_ERRALM1] Error/operation alarm  
Measures:        [TYPE\_E2] Stop deceleration.  
Main cause:       The condition that cannot be calculated occurred during internal processing.

- [Subcode]  
1: Auto tuning

Action to take:    Contact us.

**Long:**    エンザンフカ  
          CantCalc  
**Short:**    エンザンフカ  
          CantCalc

---

**Error number**                    **56**    **M interface error**

---

Error type:        [KIND\_ERRALM2] Error/operation alarm  
Measures:        [TYPE\_E2] Stop deceleration.  
Main cause:       An M function interface error occurred.  
Action to take:

**Long:**    M インタフェースイェウ  
          M\_InterfaceError  
**Short:**    M\_I/F イェウ  
          M\_I/F

Error number	60	Cannot interpret
Error type:	[KIND_ERRALM2] Error/operation alarm	<b>Long:</b> シレイホシヤクフカ CantInterpret
Measures:	[TYPE_E2] Stop deceleration.	<b>Short:</b> シレイホシヤクフカ CantIntp
Main cause:	The command cannot be interpreted.	
Action to take:		
Error number	61	Command format error
Error type:	[KIND_ERRALM2] Error/operation alarm	<b>Long:</b> シレイフオフォーマットイシヨウ FormatError
Measures:	[TYPE_E2] Stop deceleration.	<b>Short:</b> シレイフオフォーマット FormatErr
Main cause:	A command format error occurred.	
Action to take:		
Error number	62	Data is out of range
Error type:	[KIND_ERRALM2] Error/operation alarm	<b>Long:</b> データハンイカゲイ Out_ofRange
Measures:	[TYPE_E2] Stop deceleration.	<b>Short:</b> データハンイカゲイ OutOfRange
Main cause:	The data is out of range.	
Action to take:		
Error number	63	Operation error
Error type:	[KIND_ALM] Operation alarm	<b>Long:</b> ソウサイジヨウ OperationError
Measures:	[TYPE_E2] Stop deceleration.	<b>Short:</b> ソウサイジヨウ OperateErr
Main cause:	An operation error occurred. [Subcode]	
	1: Prohibited operation in machine setting mode	
	2: Prohibited operation while holding an operation	
Action to take:		
Error number	65	Illegal parameter and monitor number
Error type:	[KIND_ERRALM2] Error/operation alarm	<b>Long:</b> フセイハシヨウ IllegalNo
Measures:	[TYPE_E2] Stop deceleration.	<b>Short:</b> フセイハシヨウ IllegalNo
Main cause:	The parameter and monitor of a non-existent number was specified.	
Action to take:		

---

**Error number**            **66**    **Illegal device**

---

**Long:**    フェイデ<sup>ド</sup>ハイスレイ  
          IllegalDevice

**Short:**    フェイデ<sup>ド</sup>ハイス  
          IlgDevice

Error type:    [KIND\_ALM] Operation alarm

Measures:    [TYPE\_E2] Stop deceleration.

Main cause:    An operation was attempted using a device whose operation was prohibited.

Action to take:

---

**Error number**            **67**    **Write protected**

---

**Long:**    カキコミフカ  
          WriteProtected

**Short:**    カキコミフカ  
          WrtProtect

Error type:    [KIND\_ERRALM2] Error/operation alarm

Measures:    [TYPE\_E2] Stop deceleration.

Main cause:    A write access was attempted to an area that is prohibited to be written.

Action to take:

---

**Error number**            **80**    **No such command**

---

**Long:**    シレイヒソクサ<sup>イ</sup>  
          NoSuchCommand

**Short:**    シレイヒソクサ<sup>イ</sup>  
          NoSuchCmd

Error type:    [KIND\_ALM] Operation alarm

Measures:    [TYPE\_E2] Stop deceleration.

Main cause:    A non-existent command was specified.

Action to take:

---

**Error number**            **81**    **Not registered**

---

**Long:**    トウロクミカンリョウ  
          NotRegistered

**Short:**    トウロクミカン  
          NotRegistd

Error type:    [KIND\_ALM] Operation alarm

Measures:    [TYPE\_E2] Stop deceleration.

Main cause:    Registration did not complete normally.

Action to take:

---

**Error number**            **82**    **Out of memory**

---

**Long:**    ヨウリョウブ<sup>ツク</sup>  
          Out\_ofMemory

**Short:**    ヨウリョウブ<sup>ツク</sup>  
          MemoryLow

Error type:    [KIND\_ALM] Operation alarm

Measures:    [TYPE\_E2] Stop deceleration.

Main cause:    Insufficient memory

Action to take:

**Error number**                      **85**    **Device conflict**

---

**Error type:**            [KIND\_ALM] Operation alarm

**Measures:**            [TYPE\_E2] Stop deceleration.

**Main cause:**            An operation was attempted by another device while other device was being operated.

**Action to take:**

**Long:**            デバイス競合  
DeviceConflict

**Short:**            デバイス競合  
DevConflic