

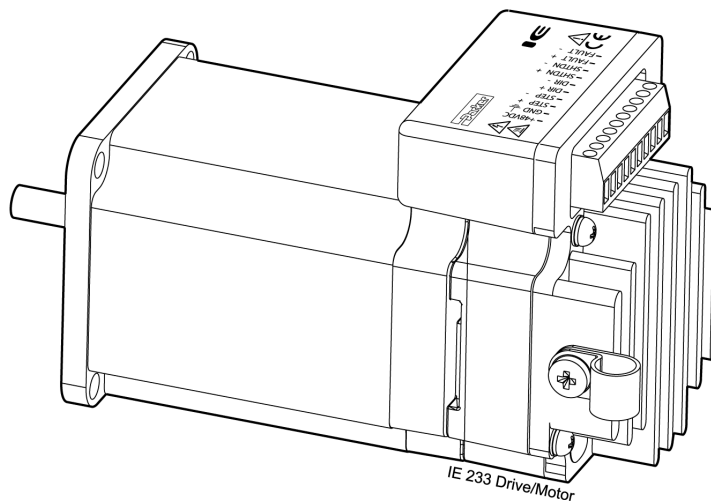

p/n 88-025085-01

Integral E Integrated Drive/Motor Installation Guide

Effective: September, 2004



IMPORTANT

User Information



Warning!



Integral E Integrated Drive/Motor is used to control electrical and mechanical components of motion control systems, as well as move mechanical components. You should test your motion control system for safety under all potential conditions. Failure to do so may result in damage to equipment and/or serious injury to personnel.

The products and information in this guide are the proprietary property of Parker Hannifin Corporation or its licensors, and may not be copied, disclosed, or used for any purpose not expressly authorized by the owner thereof.

Since Parker Hannifin constantly strives to improve all of its products, we reserve the right to change this guide, and software and hardware mentioned therein, at any time without notice.

In no event will the provider of the equipment be liable for any incidental, consequential, or special damages of any kind or nature whatsoever, including but not limited to lost profits arising from or in any way connected with the use of the equipment or this guide.

© 2004 Parker Hannifin Corporation
All Rights Reserved

Technical Assistance

Contact your local automation technology center (ATC) or distributor.

North America and Asia

Parker Hannifin
5500 Business Park Drive
Rohnert Park, CA 94928
Telephone: (800) 358-9070 or (707) 584-7558
Fax: (707) 584-3793
Email: emn_support@parker.com
Internet: <http://www.parkermotion.com>

Germany, Austria, Switzerland

Parker Hannifin GmbH
Electromechanical Automation - Europe
Postfach: 77607-1720
Robert-Bosch-Str. 22
D-77656 Offenburg
Telephone: +49 (0) 781 509-0
Fax: +49 (0) 781 509-98176
Email: eme_application@parker.com

Europe (non-German speaking)

Parker Hannifin
21 Balena Close
Poole, Dorset
England BH17 7DX
Telephone: +44 (0) 1202 69 9000
Fax: +44 (0) 1202 69 5750
Email: eme_application@parker.com

Italy

Parker Hannifin
20092 Cinisello Balsamo
Milan, Italy via Gounod, 1
Telephone: +49 (0) 781 509-0
Fax: +49 (0) 781 509-176
Email: sales.sbc@parker.com



Automation

Technical Support E-mail

emn_application@parker.com

Table of Contents

Technical Assistance	ii
Important Information for Users	x
Chapter 1 Introduction	1
Checking Your Shipment.....	2
Accessories	2
Compatible Parker Hannifin Products	3
Integrated Drive/Motor Models	3
About This Guide.....	3
Assumptions of Technical Experience	3
Technical Support	3
Integral E Drive/Motor Unit—Overview	4
DIP switches	6
Inputs and Outputs	6
Anti-Resonance	6
Protective Circuits.....	6
Mounting	6
Chapter 2 Installation	7
Installation Safety Requirements.....	8
Precautions	8
Electrical Noise Guidelines	8
Preparing for Installation	9
Recommended Installation Process	9
Automatic Test.....	10
1. Set DIP Switches for Automatic Test Function.....	10
2. Connect DC Power Supply	11
3. Apply Power	11
4. Observe the Automatic Test	12
5. Stop the Automatic Test	12
Test Setup with a Controller	12
1. Set DIP Switches	12
2. Connect a Controller	12
3. Connect DC Power Supply	13
4. Apply Power	14
5. Command Clockwise (CW) Motion.....	14
6. Command Counterclockwise (CCW) Motion	14
7. Stop the Controller Setup Test	14
Confirm Your Drive/Motor Selection.....	14
Drive/Motor Specifications	15
Motor Performance	15
Speed/Torque Curves.....	16
Drive/Motor Dimensions	17
Installation	18
1. Set DIP Switches	18
Default Settings	18
Automatic Standby.....	19
Drive Resolution	19
Automatic Test.....	19
2. Connect a Controller—Inputs & Outputs	19
Step Input.....	20
Direction Input.....	21
Shutdown Input.....	22

Fault Output	22
Making the Controller Connections	22
I/O Connector Pinouts	25
6K Controller	25
RBC Breakout Box	26
ACR9000/RBC 1505 Breakout Box	27
3. Mount the Drive/Motor	28
Drive/Motor Modifications	28
Drive/Motor Dimensions	29
Mounting Clearance	30
Environmental Specifications and Considerations	30
4. Connect the Drive/Motor to the Load	31
Single-Flex Coupling	32
Double-Flex Coupling	32
Rigid Coupling	32
Coupling Manufacturers	33
5. Connect a DC Power Supply	33
To make the connection	33
Applying Power	34
Choosing a Power Supply	34
Peak Power Ratings	35
Conversions	35
Power Supply Requirements	36
Drive/Motor Type	36
3. Test the Installation	36
Test Procedure	36
Motor Performance	37
Chapter 3 Troubleshooting	38
Troubleshooting Basics	39
Protective Circuits	39
Overtemperature Protection	39
Short Circuit Protection	39
Testing the Unit	40
Reducing Electrical Noise	40
Maintenance	40
Common Problems and Solutions	41
Technical Support	42
Chapter 4 Schematic	43
Appendix A Regulatory Compliance: UL and CE	45
System Installation Overview	46
General Safety Considerations	46
General EMC Considerations	46
Installing the Integral E Integrated Drive/Motor	47
Precautions	47
A Safe Installation – Meeting the Requirements of the Low Voltage Directive (LVD)	47
A Highly-Immune, Low-Emission Installation—Meeting the Requirements of the Electromagnetic Compatibility (EMC) Directive	47
Typical EMC Installation	52
Panel Installation in an Earth-Bonded Metallic Enclosure	53
Regulatory Agencies	54
Standards of Compliance	54
Appendix B Specifications	55
Environmental Specifications	56
Heatsinking	56

Cooling and Temperature	56
Mounting Clearance.....	57
Overtemperature Shutdown Fault	57
Humidity	57
Liquids.....	57
Airborne Contaminants	58
Mechanical Specifications	59
Drive/Motor Dimensions	59
Drive/Motor Specifications	60
Motor Performance	60
Speed/Torque Curves.....	61
Electrical Specifications.....	62
Peak Power Ratings	62
Conversions	62
Power Supply Requirements	63
Short Circuit Protection.....	63
External I/O Connectors	64
Step Input.....	65
Direction Input.....	66
Shutdown Input.....	67
Fault Output	67
DIP Switches	68
Default Settings	68
Automatic Standby.....	68
Drive Resolution	69
Automatic Test.....	69

Table of Tables

Table 1 Ship Kit	2
Table 2 Integral E Drive/Motor Accessories	2
Table 3 Drive/Motor Parameters	15
Table 4 Motor Performance Specifications	15
Table 5 Step Input Specifications	20
Table 6 Direction Input Specifications	21
Table 7 Shutdown Input Specifications	22
Table 8 6K Controller Connector Pinout	25
Table 9 RBC Breakout Box Connector Pinout	26
Table 10 ACR9000/RBC 1505 Breakout Box Connector Pinout	27
Table 11 Environmental Specifications	30
Table 12 Peak Power Ratings	35
Table 13 Current Draw from DC Power Supply	36
Table 14 Motor Performance Specifications	37
Table 15 Common Problems and Solutions	41
Table 16 Mains Filter Selection	50
Table 17 Enclosure Mounting Clamps	51
Table 18 Typical EMC Installation	52
Table 19 Regulatory Agencies	54
Table 20 Environmental Specifications	56
Table 21 Drive/Motor Parameters	60
Table 22 Motor Performance Specifications	60
Table 23 Peak Power Ratings	62
Table 24 Current Draw from DC Power Supply	63
Table 25 Step Input Specifications	65
Table 26 Direction Input Specifications	66
Table 27 Shutdown Input Specifications	67

Table of Figures

Figure 1 Integral E System Components, 2-Cable Installation	4
Figure 2 Integral E System Components, 1-Cable Installation	5
Figure 3 Motion Control System Block Diagram	5
Figure 4 DC Power and I/O Connector	9
Figure 5 DIP Switch Locations and Automatic Test Settings	10
Figure 6 DC Power Supply Connections	11
Figure 7 Controller Connections	13
Figure 8 DC Power Supply Connections	13
Figure 9 Speed Torque Curves	16
Figure 10 Drive/Motor Dimensions	17
Figure 11 DIP Switch Locations and Settings	18
Figure 12 Drive/Motor I/O Connector	20
Figure 13 Controller Connections, Separate Cable	23
Figure 14 Controller Connections, Shared Cable	24
Figure 15 6K Controller Connector	25
Figure 16 RBC Breakout Box Connector	26
Figure 17 ACR9000/RBC 1505 Breakout Box Connector	27
Figure 18 Drive/Motor Dimensions	29
Figure 19 Drive/Motor Panel Layout Dimensions	30
Figure 20 Load Misalignment Conditions	32
Figure 21 DC Power Supply Connection, Separate Cable	33

Figure 22 DC Power Supply Connection, Shared Cable	34
Figure 23 Integral E I/O Circuit Schematic.....	44
Figure 24 360° Bonding Techniques.....	48
Figure 25 Typical EMC-Compliant Panel Installation.....	53
Figure 26 Panel Layout Requirements.....	57
Figure 27 Drive/Motor Dimensions.....	59
Figure 28 Speed Torque Curves	61
Figure 29 Controller Connections.....	64
Figure 30 DIP Switch Locations and Settings	68

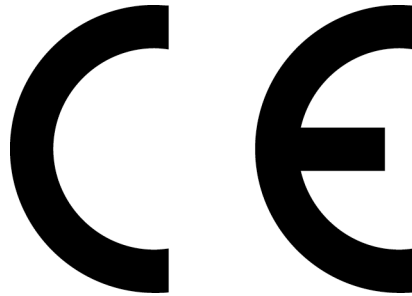

Product Type.....Integral E Integrated Drive/Step Motor

The aforementioned product complies with the requirements of directives:

- EMC Directive 89/336/EEC
- CE Marking Directive 93/68/EEC.

Provided the installation requirements described in this guide are met, and there are no special requirements of the installation and operating environment so that the application may be considered typical.

The above equipment conforms with the protection requirements of Council Directive 89/336/EEC as amended by Directive 92/31/EEC on the approximation of the laws of the Member States relating to Electromagnetic Compatibility when installed, operated and maintained as intended.

In accordance with IEC 61800-3:1997 (Adjustable speed electrical power drive systems) this product is of the restricted sales distribution class which meets the needs of an industrial environment when installed as directed. However, further measures may need to be taken for use of the product in a domestic environment.

The installation requirements are detailed in the Information supplied with the equipment. The equipment is sold only to competent system builders.

Compliance is demonstrated by the application of the following standards:

- BS EN 50081-2 (1994) Electromagnetic compatibility. Generic emission standard Part 2. Industrial Environment.
- BS EN 61000-6-2 (1999) Electromagnetic compatibility. Part 6-2: Generic Standards – Immunity for industrial environments.
- BS EN 61800-3 (1997) Adjustable speed electrical power drive systems. Part 3 : EMC product standard including specific test methods



Warning!



Risk of damage and/or personal injury

The Integral E Integrated Drive/Motor described in this guide contain no user-serviceable parts. Attempting to open the case of any unit, or to replace any internal component, may result in damage to the unit and/or personal injury. This may also void the warranty.

The following symbols appear in this guide:

Symbols	Description
	Protective Earth Ground
	Functional Earth (Ground) Terminal
	Shield, Frame, or Chassis Terminal
	Digital Ground
	Isolated Ground
	Caution Risk of Electrical Shock
	Caution, Refer to Accompanying Documentation

Important Information for Users

It is important that motion control equipment is installed and operated in such a way that all applicable safety requirements are met. It is your responsibility as an installer to ensure that you identify the relevant safety standards and comply with them; failure to do so may result in damage to equipment and personal injury. In particular, you should study the contents of this user guide carefully before installing or operating the equipment.

The installation, set up, test, and maintenance procedures given in this guide should only be carried out by competent personnel trained in the installation of electronic equipment. Such personnel should be aware of the potential electrical and mechanical hazards associated with motion control equipment—please see the safety warnings below. The individual or group having overall responsibility for this equipment must ensure that operators are adequately trained.

Under no circumstances will the suppliers of the equipment be liable for any incidental, consequential or special damages of any kind whatsoever, including but not limited to lost profits arising from or in any way connected with the use of the equipment or this guide.



Safety Warning!



High-performance motion control equipment is capable of producing rapid movement and very high forces. Unexpected motion may occur especially during the development of controller programs. **KEEP WELL CLEAR** of any machinery driven by stepper or servo motors. Never touch any part of the equipment while it is in operation.

This product is sold as a motion control component to be installed in a complete system using good engineering practice. Care must be taken to ensure that the product is installed and used in a safe manner according to local safety laws and regulations. In particular, the product must be positioned such that no part is accessible while power may be applied.

This and other information from Parker Hannifin Corporation, its subsidiaries, and authorized distributors provides product or system options for further investigation by users having technical expertise. Before you select or use any product or system, it is important that you analyze all aspects of your application and review the information concerning the product in the current product catalog. The user, through its own analysis and testing, is solely responsible for making the final selection of the system and components and assuring that all performance, safety, and warning requirements of the application are met.

If the equipment is used in any manner that does not conform to the instructions given in this user guide, then the protection provided by the equipment may be impaired.

The information in this user guide, including any apparatus, methods, techniques, and concepts described herein, are the proprietary property of Parker Hannifin or its licensors, and may not be copied, disclosed, or used for any purpose not expressly authorized by the owner thereof.

Since Parker Hannifin constantly strives to improve all of its products, we reserve the right to modify equipment and user guides without prior notice. No part of this user guide may be reproduced in any form without the prior consent of Parker Hannifin.

CHAPTER ONE

Introduction

IN THIS CHAPTER

- Integral E Drive/Motor Unit—Overview 2
- Checking Your Shipment 2
- Compatible Parker Hannifin Products 3
- Assumptions of Technical Experience 3
- Technical Support 3

Checking Your Shipment

The Integral E Integrated Drive/Motor ships with a removable ten-position screw terminal connector installed in the unit. Inspect the drive/motor and parts for damage.

Integral E Ship Kit	
Description	Part Number
Screw terminal connector, 10-position, installed	43-025025-01
R-clamp	58-018127-01
Screw (for R-clamp)	51-006055-01
<i>Integral E Quick Reference Guide</i>	88-025203-01

Table 1 Ship Kit

For the latest additions, see our website at www.parkermotion.com.

Accessories

Integral E Accessories	
Description	Part Number
Controller cables¹	
6K to flying leads	71-017003-xx
ACR to flying leads	71-022344-xx
DC Power Supplies²	
500W, 120 VAC in, 48 VDC out	PS500W120-48
500W, 240 VAC in, 48 VDC out	PS500W240-48
1000W, 120 VAC in, 48 VDC out	PS1000W120-48
1000W, 240 VAC in, 48 VDC out	PS1000W240-48
1. Cable comes in a 4-foot (1,219 mm) or 10-foot length (3,048 mm) (in the part number, -xx = -04 or -10).	
2. Parker Hannifin has not verified these power supplies for EMC compliance when used with the Integral E.	
Note: A power cord <i>does not</i> ship with the unit.	

Table 2 Integral E Drive/Motor Accessories

For the latest additions, see our website at www.parkermotion.com.

Compatible Parker Hannifin Products

The Integral E Integrated Drive/Motor is compatible with a range of Parker stepper controllers (single- and multi-axis).

- ACR Controllers 1505, 2000, 8010, 8020, 9000
- 6K Motion Controllers

Integrated Drive/Motor Models

The integrated drive/motor comes in three models distinguished by the torque of the motor.

- IE231 Single stack
- IE232 Double stack
- IE233 Triple stack

About This Guide

The purpose of this guide is to help you install the Integral E Integrated Drive/Motor in a motion control system by providing specifications, step-by-step procedures, and safety information.

Assumptions of Technical Experience

To install and troubleshoot the Integral E Drive/Motor, you should have a fundamental understanding of the following:

- Electronic concepts such as voltage, current, and switches.
- Mechanical motion control concepts such as inertia, torque, velocity, distance, and force.

Technical Support

If you cannot find solutions to your questions in this document, *Integral E Integrated Drive/Motor Hardware Installation Guide*, contact your local Automation Technology Center (ATC) or distributor for assistance.

If you need to talk to our in-house Application Engineers, please contact us at the numbers listed in "Technical Assistance" on the inside cover, page ii.

Integral E Drive/Motor Unit—Overview

The Integral E Integrated Drive/Motor is a combination stepper drive and motor for use in motion control systems. Its compact design requires less space and fewer cables than separate motor and drive units, and offers easy installation. It comes in three models, distinguished by the torque of the motor.

The integrated drive/motor operates from an external DC power supply, in the range of 24 VDC to 48 VDC (–10%, +5%). It provides connections for DC power and I/O by means of a ten-position removable screw terminal connector. The unit's automatic test, drive resolution, and automatic standby functions are configured with DIP switches. All connectors and switches are on the back (heatsink side) of the unit.

“Chapter 2 Installation” provides detailed information about the Integral E Drive/Motor and procedures for installing it. Specifications for the unit appear where relevant in the installation procedures, and also are collected in “Appendix B Specifications” for convenient reference.

Figure 1 and Figure 2 and show the Integral E in a motion control system. Figure 1 shows a two-cable installation, which is easy to make EMC-compliant. Figure 2 shows a one-cable installation, which is typical but may not be EMC-compliant. (For EMC installation guidelines, see “Appendix A Regulatory Compliance: UL and CE.”)

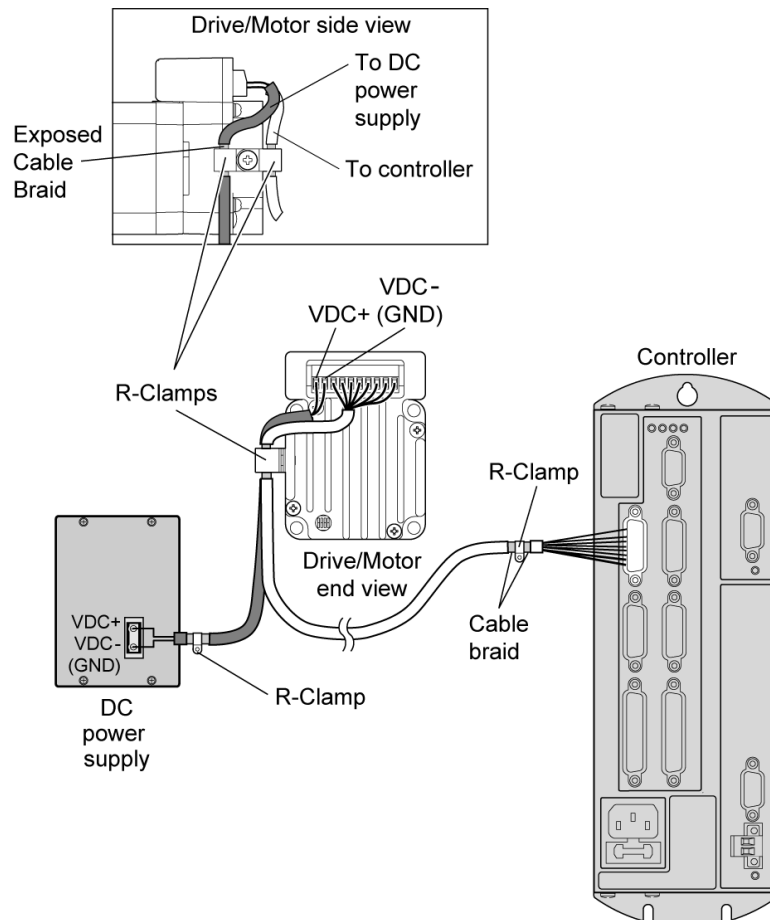

Figure 1 Integral E System Components, 2-Cable Installation

Note: Parker Hannifin sells the type of controller cable shown in Figure 1.

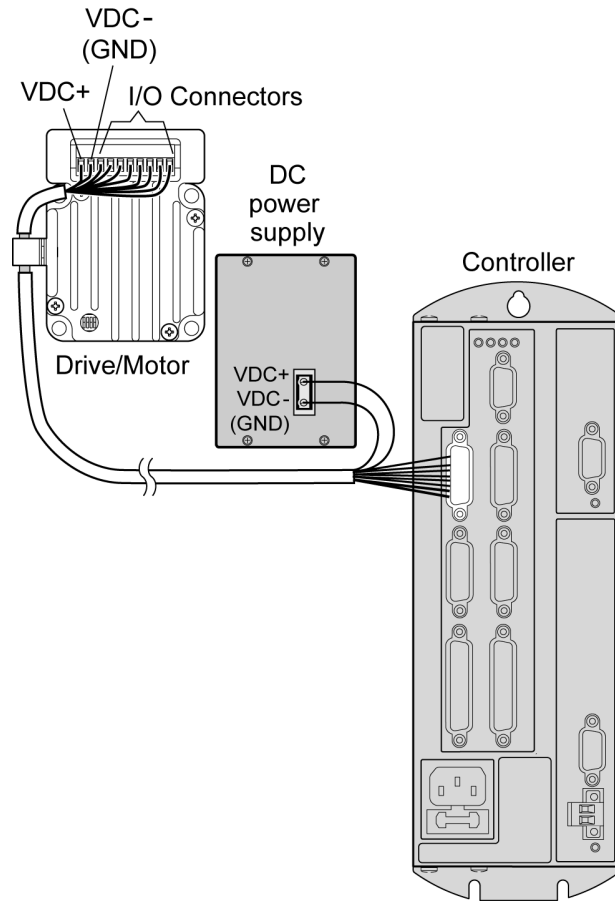

Figure 2 Integral E System Components, 1-Cable Installation

Note: Parker Hannifin does not sell the type of cable shown in Figure 2.

In a motion control system, the controller sends step, direction, and shutdown signals to the Integral E's internal drive while monitoring the fault output. For each step pulse it receives, the drive commutates the motor to increment the rotor position. Figure 3 illustrates this action.

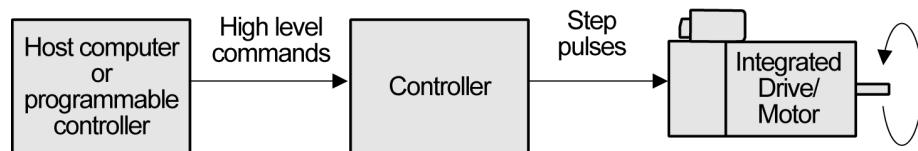

Figure 3 Motion Control System Block Diagram

Note: The necessity of a host computer or programmable controller depends upon the controller's capabilities.

DIP switches

Four DIP switches are located on the back (heatsink side) of the Integral E Drive/Motor, near the bottom. These switches configure the drive for automatic test, drive resolution, and automatic standby. (Figure 5 on page 10 shows the location and functions of the switches.)

Inputs and Outputs

All communication with the controller takes place through eight of ten positions in a removable screw terminal connector on the back (heatsink side) of the Integral E unit. Figure 4 on page 9 shows the location and names of the I/O connectors. The available inputs and outputs are:

- Step Input
- Direction Input
- Shutdown Input
- Fault Output

Anti-Resonance

All step motors are subject to resonance, and to ringing after quick, transient moves. The Integral E Integrated Drive/Motor is equipped with an anti-resonance circuit. This is a general-purpose damping circuit, which provides aggressive and effective damping.

Protective Circuits

Two circuits in the Integral E Drive/Motor automatically provide protection for the drive

- Overtemperature Protection
- Short Circuit Protection

These circuits are described in “Chapter 3 Troubleshooting” and “Appendix B Specifications.”

Mounting

The Integral E Integrated Drive/Motor is designed for a minimum-mounting-area configuration. The device is fully enclosed—it does not have air vents. The device’s face flange (NEMA 23 frame) should be mounted to a large thermal mass, such as an unpainted, thick, steel or aluminum plate. The face flange also serves as a heatsink.

You’ll find mounting requirements and procedures in “Chapter 2 Installation” and “Appendix B Specifications.”

CHAPTER TWO

Installation

IN THIS CHAPTER

- Installation Safety Requirements
- Preparing for Installation
- Automatic Test
- Installation

Installation Safety Requirements

The Integral E Drive/Motor is made available under “Restricted Distribution” for use in the “Second Environment” as described in EN 61800-3 1996, on page viii. The device is UL-recognized under standard 508C.

Precautions

During installation, take the normal precautions against damage caused by electrostatic discharges.

- Wear earth-grounding wrist straps.
- Include a mains power switch or circuit breaker within easy reach of the machine operator. Label clearly the switch or breaker as the disconnecting device.



Warning!



Perform test and installation procedures in a properly grounded environment. Parker Hannifin recommends the use of a grounding strap.

You must ground the drive/motor case. Large potentials can develop at the motor case that can create a lethal shock hazard if the drive/motor case is not grounded.

ALWAYS REMOVE POWER TO THE INTEGRAL E INTEGRATED DRIVE/MOTOR BEFORE CONNECTING ELECTRICAL DEVICES (for example, inputs, outputs, etc.).

Electrical Noise Guidelines

- Ensure that all components are properly grounded.
- Ensure that all wiring is properly shielded.

Preparing for Installation

This section provides an overview of installation and the necessary preparatory procedures. Before mounting and installing the Integral E Drive/Motor, you need to test functioning and connections, as well as confirm that you've selected the appropriate device for your application.

Recommended Installation Process

The following steps present an overview of the installation process. Subsequent sections of the chapter provide detailed installation procedures.

1. Review the safety requirements in "Appendix A Regulatory Compliance: UL and CE."
2. Perform the automatic test.
3. Perform a test setup with a controller.
4. Verify your drive/motor selection: speed/torque, dimensions, and other specifications.
5. Configure the DIP switches.
6. Mount the drive/motor.
7. Connect the load to it.
8. Connect DC power.
9. Test the installation.
10. Use the procedures in "Chapter 3 Troubleshooting" to solve any installation problems.

Figure 4 shows the locations and names of the Integral E Drive/Motor DC power and I/O connectors that you use during the installation process.

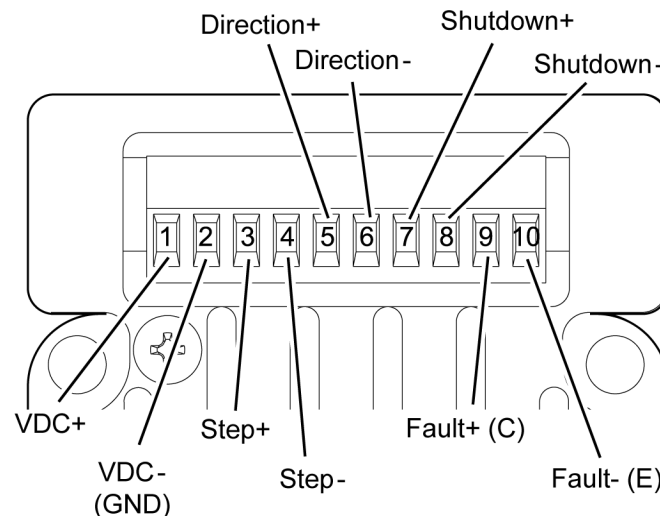

Figure 4 DC Power and I/O Connector

Automatic Test

The automatic test verifies that the drive/motor works properly. Follow the procedure in this section to perform the test on the Integral E Drive/Motor. Once you set the DIP switches and apply DC power, the automatic test begins. The motor shaft rotates two revolutions in an alternating mode at one revolution per second (1 rps), until you remove power or activate the shutdown circuit.

This is a benchtop procedure—perform it before you connect a controller or mount the drive/motor.

1. Set DIP Switches for Automatic Test Function



Warning!



Do not connect power before setting DIP switches. Never change DIP switch settings with power applied. Possible damage or injury may occur.

Figure 5 shows the location and settings of the four-position DIP switch on the back of the drive/motor. Use a small screw driver or the end of a paper clip to move the individual switches up or down.

Set DIP switch 4 to the **on** (up) position to enable the automatic test function. (DIP switches 1, 2, and 3 should be in the **off** (down) position—the factory default.)

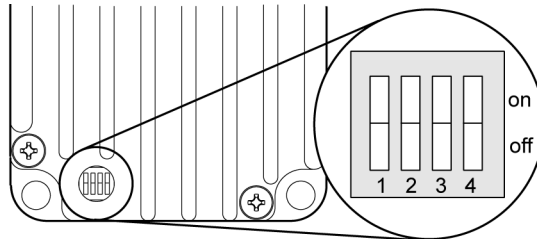

	1	2	3	4
Automatic Standby				
Enabled	on			
Disabled	off			
Drive Resolution				
3,600		on	on	
36,000		on	off	
2,500		off	on	
25,000		off	off	
Automatic Test*				
Enabled				on
Disabled				off

*1 rps for 2 revolutions in each direction until shutdown or power removed

Figure 5 DIP Switch Locations and Automatic Test Settings

2. Connect DC Power Supply

Connect one end of your power cable or conductors to the drive/motor's VDC+ (screw terminal position 1) and VDC- (screw terminal position 2), as shown in Figure 6. Connect the other end to a 24 VDC to 48 VDC power supply.

**Warning!**

Do not reverse VDC+ and VDC-. Reversing these connections can seriously damage the drive.

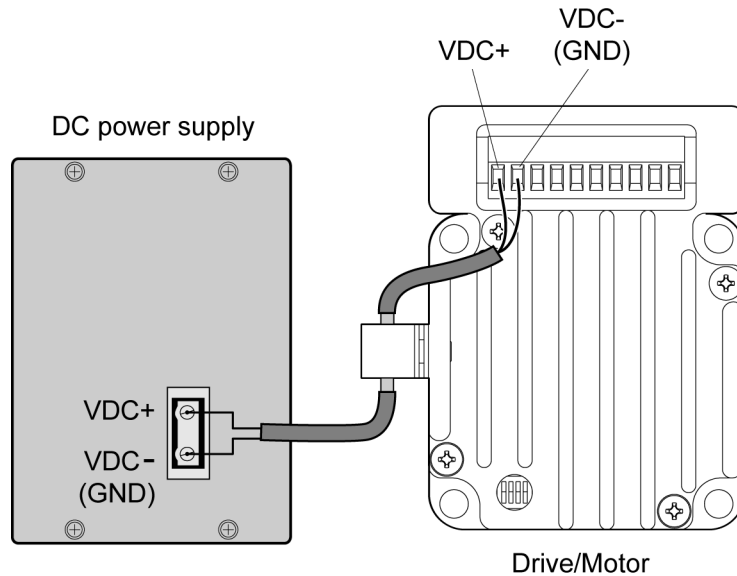



Figure 6 DC Power Supply Connections

3. Apply Power

The Integral E Drive/Motor *does not* have an on/off switch. *When you connect power, the automatic test will begin*—the drive will turn on and the motor will start turning. Therefore, before you apply power to the drive/motor:

- Properly secure the motor.
- Do not attach a load to the motor shaft.

**Warning!**

Operating the Integral E Drive/Motor for extended periods without proper mounting may cause the drive to fault due to overheating. Possible motor damage may occur. When you complete the automatic test, remove power to the drive/motor.

4. Observe the Automatic Test

Your Integral E Integrated Drive/Motor should now run in the automatic test mode. The motor shaft rotates at approximately one rps, in an alternating mode of approximately two revolutions, until you remove power.

5. Stop the Automatic Test

Disconnect power to stop the drive/motor. Set DIP switch 4 to the **off** (down) position to disable the Automatic Test function.

Test Setup with a Controller

Test the Integral E Drive/Motor with a controller by following the steps in this section to command the motor to turn (rather than using the drive/motor's Automatic Test function).

1. Set DIP Switches

Confirm that DIP switch 4 is in the **off** (down) position to disable the Automatic Test function. All four DIP switches should be in the **off** (down) position for the controller setup test.



Warning!



Remove power before setting DIP switches. Possible damage or injury may occur.

2. Connect a Controller

Connect the step and direction positions of the drive/motor's I/O screw terminal connector to the corresponding step and direction outputs on your controller. Figure 7 illustrates this connection.

Note: For information on cables, and wiring, and compatible Parker controllers, see "I/O Connector Pinouts," starting on page 25. Figure 23 "Integral E I/O Circuit Schematic" on page 44 provides additional information.



Warning!



Never connect or disconnect any component to or from the drive/motor with power applied. System damage or personal injury may occur.

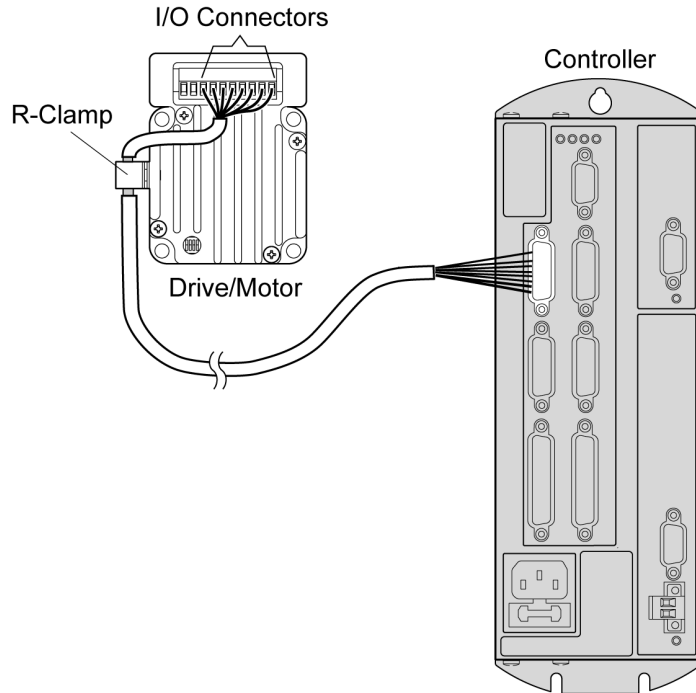

Figure 7 Controller Connections

Note: Parker Hannifin sells the type of controller cable shown in Figure 7.

3. Connect DC Power Supply

Connect one end of your power cable/conductors to the VDC+ (position 1) and VDC- (position 2) connectors in the drive/motor's ten-position screw terminal connector, as shown in Figure 8. Connect the other end to the corresponding connectors in a 24 VDC to 48 VDC power supply.

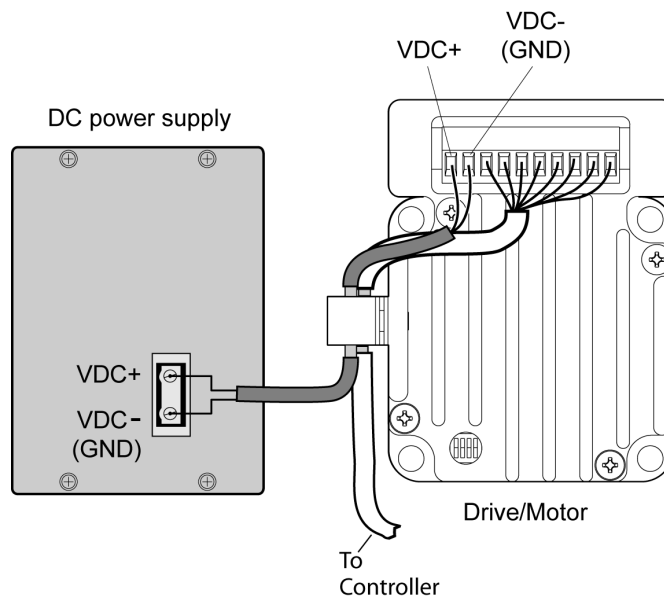

Figure 8 DC Power Supply Connections



Warning!



Do not reverse VDC+ and VDC-. Reversing these connections can seriously damage the drive.

4. Apply Power

The Integral E Drive/Motor *does not* have an on/off switch. Therefore, before you apply power to the drive/motor:

- Properly secure the motor.
- Do not attach a load to the motor shaft.

This test assumes that your controller's motor resolution is set to 25,000 steps per revolution. This is the default motor resolution setting for the Integral E Drive/Motor.

5. Command Clockwise (CW) Motion

Using the controller, send step pulses to the drive that will rotate the motor one clockwise revolution (25,000 step pulses) at 1 rps (25,000 steps per second).

Refer to the controller's user guide for specific operating instructions.

6. Command Counterclockwise (CCW) Motion

Using the controller, send step pulses to the drive that will rotate the motor one CCW revolution at 1 rps. The drive's default direction is counterclockwise (i.e., if the direction input is not activated, the motor rotates counterclockwise. If the direction input is activated, the motor rotates clockwise).

7. Stop the Controller Setup Test

When you have successfully commanded motion, you have completed all testing. Disconnect power to the drive/motor, then disconnect the controller from the drive/motor.

Confirm Your Drive/Motor Selection

Confirm that you have selected the appropriate drive/motor for your application by reviewing the information on speed/torque curves, specifications, and motor dimensions in this section. Once you've confirmed your selection, you can proceed with permanent installation.

If you determine that the drive/motor does not meet the requirements of your application, contact Parker Hannifin. Contact information is on page ii.

Drive/Motor Specifications

Table 3 provides parameters, bearings information, and certifications for the Integral E Integrated Drive/Motor

Parameters	Units	IE231	IE232	IE233
Static Torque	oz-in (Nm)	67.1 0.473726	148.5 1.04841	244.2 1.724052
Rotor Inertia	oz-in ² (kg-cm ²)	0.7 0.1281	1.5 0.2745	2.6 0.4758
Drive Current	A pk A rms	2.80 1.98	2.80 1.98	2.80 1.98
Detent Torque	oz-in (N-m)	2.63 0.019	5.90 0.042	8.38 0.059
Bearings				
Thrust Load	lb (kg)	13.00 5.91	13.00 5.91	13.00 5.91
Radial Load (0.79 inches from face)	lb (kg)	15.00 6.82	15.00 6.82	15.00 6.82
Shaft End Play	in at 2.2 lbs (mm)	0.003 0.0762	0.003 0.0762	0.003 0.0762
Shaft Radial Play in at 1 lb	in (mm)	0.001 0.0254	0.001 0.0254	0.001 0.0254
Motor weight	lb (kg)	1.3 [.59]	1.8 [.82]	2.6 [1.18]
Certifications		UL recognized CE (EMC)	UL recognized CE (EMC)	UL recognized CE (EMC)

Table 3 Drive/Motor Parameters

Motor Performance

	Performance Specifications
Accuracy	±10.0 arcminutes typical (unloaded, bidirectional)
Repeatability	±5 arcseconds typical (unloaded, bidirectional)
Hysteresis	Less than 2 arcminutes—0.0334° (unloaded, bidirectional)

Table 4 Motor Performance Specifications

Speed/Torque Curves

IE231

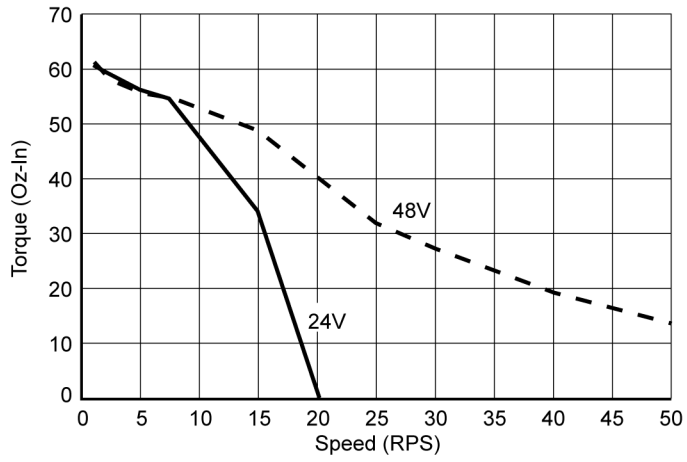

IE232

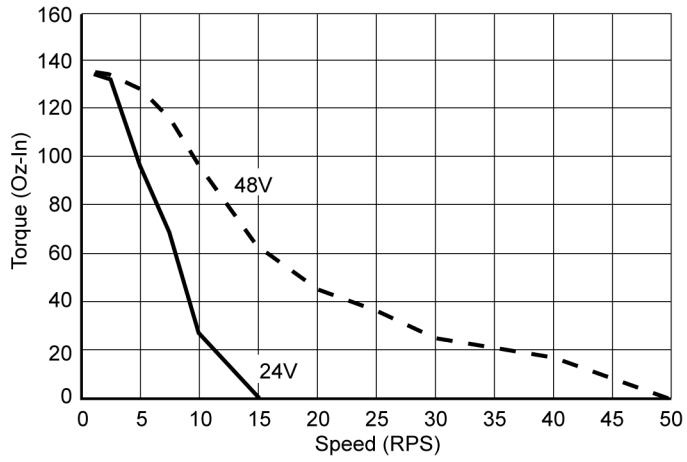

IE233

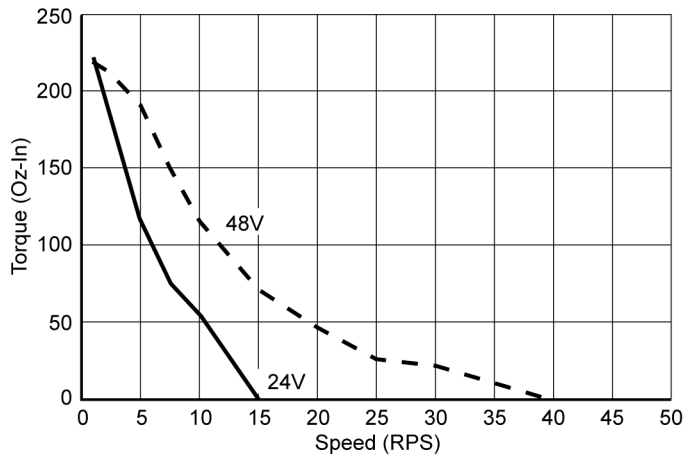

Figure 9 Speed Torque Curves

Drive/Motor Dimensions

There are three models of the Integral E Integrated Drive/Motor, which vary in torque and dimensions: IE231, IE232, and IE233. Figure 10 provides the dimensions of each model. The motor flange is a standard NEMA 23 size frame.

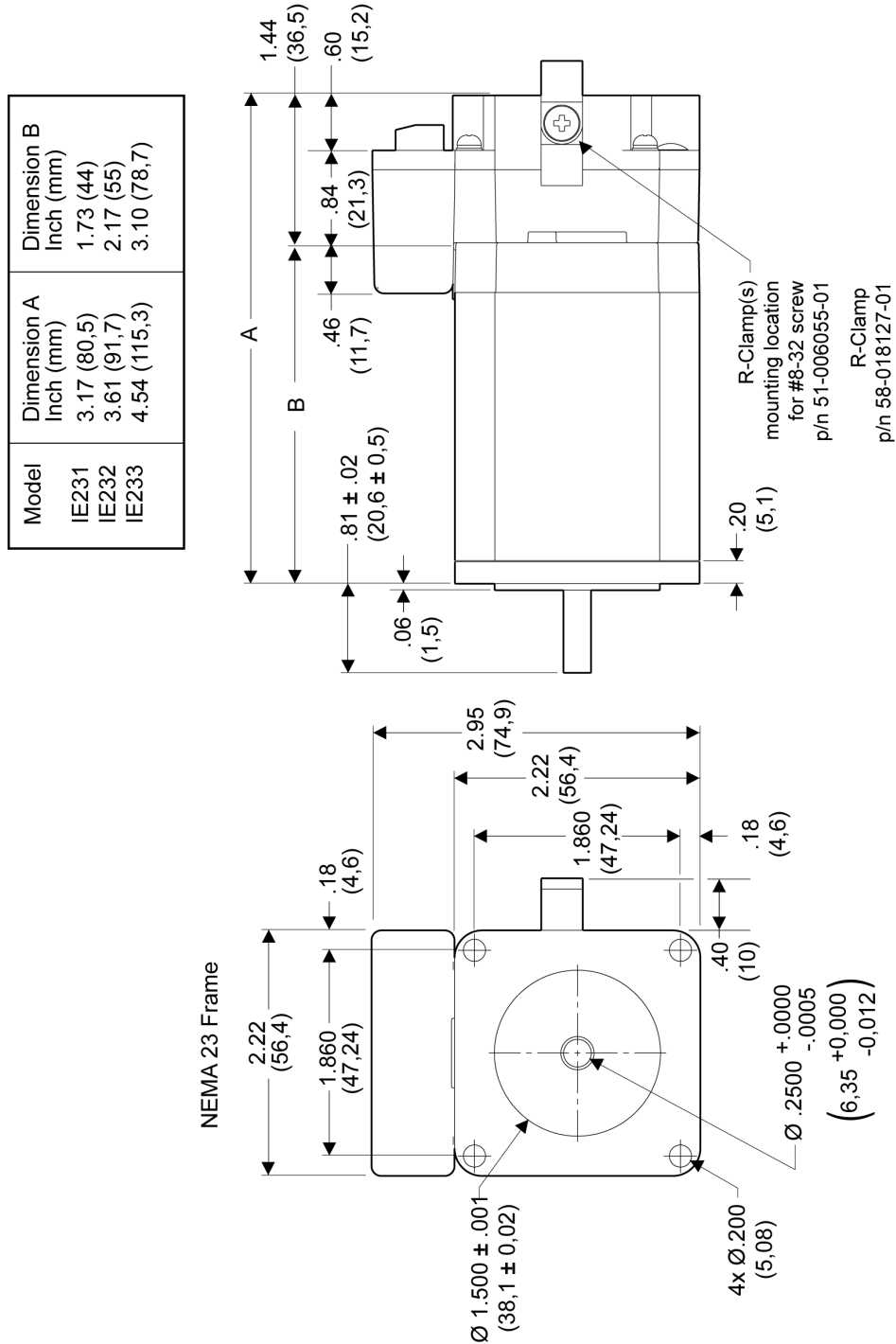

Figure 10 Drive/Motor Dimensions

Installation

Now that you've tested the motor function and the controller setup, and confirmed that you've selected the right device for your application, you're ready to install the Integral E Integrated Drive/Motor in your motion control system. Use the procedures in the rest of this chapter to permanently install the drive/motor.

1. Set DIP Switches

Figure 11 shows the location and settings for the four-position DIP switch on the back of the drive/motor.

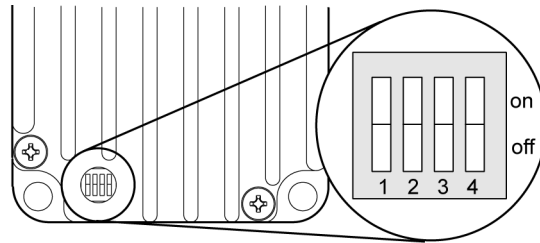

	1	2	3	4
Automatic Standby				
Enabled	on			
Disabled	off			
Drive Resolution				
3,600		on	on	
36,000		on	off	
2,500		off	on	
25,000		off	off	
Automatic Test*				
Enabled				on
Disabled				off

*1 rps for 2 revolutions in each direction until shutdown or power removed

Figure 11 DIP Switch Locations and Settings

Warning!

Remove power before setting DIP switches. Possible damage or injury may occur.

Default Settings

The factory default position for all switches is **off** (down). For the drive/motor to operate correctly, you may need to set the DIP switches for your application.

Automatic Standby

Set DIP switch 1 to the **off** (down) position if you do not use automatic standby. Set this switch to the **on** (up) position to use automatic standby. The automatic standby function allows the motor to cool when it is not moving. Automatic standby reduces motor current by 50% if the drive does not receive a step pulse for one second. Full current is restored upon the first step pulse that the drive receives. Be aware that reduced current results in reduced holding torque.

Drive Resolution

Set DIP switches 2 and 3 for drive resolution. There are four settings, measured in steps per revolution: 36,000, 25,000, 3,600, and 2,500. The default setting is 25,000 steps per revolution (switches 2 and 3 **off** or down). See Figure 11 on page 18 for drive resolution settings.

Be sure to set your controller to the same resolution as your integrated drive/motor. If the controller resolution and the drive resolution do not match, the system does not properly scale commanded accelerations and velocities.

Automatic Test

DIP switch 4 enables or disables the automatic test function, which verifies that the drive/motor works properly. Set this switch to the **on** (up) position to enable the automatic test function. For more information, see the section, “Automatic Test,” on page 10.

2. Connect a Controller—Inputs & Outputs

I/O communication takes place through eight connectors of a ten-position screw terminal connector. Figure 12 illustrates the I/O connections on the Integral E. The I/O on the drive/motor is differential and optically isolated for noise immunity. It consists of the following signals:

- Step Input
- Direction Input
- Shutdown Input
- Fault Output

Each of the signals provide connections for both the + and – inputs to allow maximum flexibility.

Specifications for input and output connections follow in this section, as well as instructions for making the connections. For additional information, see Figure 23 Integral E I/O Circuit Schematic on page 44. Pinout tables for compatible Parker controllers appear on pages 25 through 27.

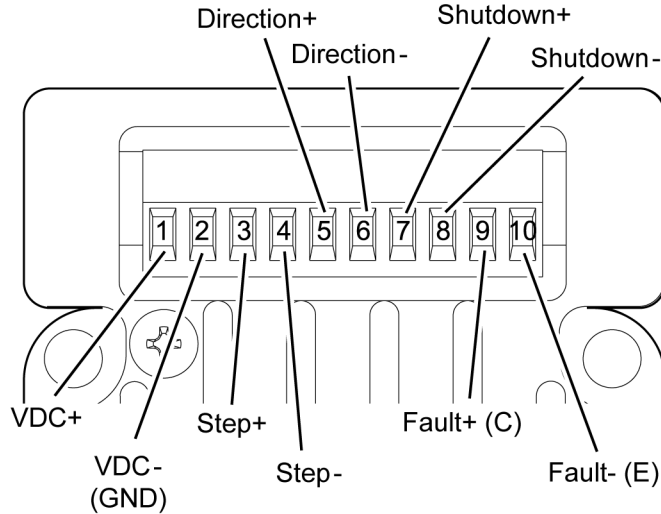

Figure 12 Drive/Motor I/O Connector

Step Input

For every step pulse the drive receives on its step input, the drive commutates the motor to increment the rotor position. To send a step pulse to the drive, apply a positive voltage to **STEP+** with respect to **STEP-**. The drive registers the pulse on the rising edge.

The step input is an optically isolated, high-speed input capable of responding to pulse rates in excess of 1.5 MHz. Driving the step input differentially ensures accurate step counts and provides the best noise immunity.

Your output driver must be capable of providing a minimum of 6.5 mA drive current at approximately 3.5 VDC drive voltage. Table 5 contains the step input connector specifications.

Step Input Specifications	
Input Current	6.5 mA minimum
	15 mA maximum
Input Voltage	3.5V minimum (min. required for on or high signal)
	5.35V maximum*
Step Pulse	200 nanosecond minimum pulse width
	200 nanosecond minimum off time
	1.5 MHz maximum pulse rate (40% to 60% duty cycle)
Optically Isolated	Yes
*You may use higher voltages if you add an external current-limiting resistor to ensure that the current does not exceed the maximum-input-current specification.	
Note: As a custom product, Parker Hannifin can modify the drive/motor for higher I/O input voltage.	

Table 5 Step Input Specifications

Direction Input

While a positive voltage is applied to **DIRECTION+** with respect to **DIRECTION-**, the drive commutates the motor in the clockwise (positive) direction as it receives step pulses on its step input.

While zero voltage (or a negative voltage) is applied to **DIRECTION+** with respect to **DIRECTION-**, the drive commutates the motor in the counterclockwise (negative) direction as it receives step pulses.

The input is optically isolated. You can drive the input differentially, or from a single-ended source.

Note: If the direction input is *not* activated (connected), the motor rotates counterclockwise.



Warning!



Reverse voltage in excess of 6 VDC may damage this device.

Your output driver must be capable of providing a minimum of 6.5 mA drive current at approximately 3.5 VDC drive voltage to ensure proper operation.

Direction input may change polarity concurrently with the first step pulse. However, we recommend that you stabilize the direction input for one microsecond before the drive receives the first pulse to allow for signal propagation delay.

Table 6 contains the direction input terminal specifications.

Direction Input Specifications	
Input Current	6.5 mA minimum
	15 mA maximum
Input Voltage	3.5V minimum (min. required for on or high signal)
	5.35V maximum*
Optically Isolated	Yes
*You may use higher voltages if you add an external current-limiting resistor to ensure that the current does not exceed the maximum-input-current specification.	
Note: As a custom product, Parker Hannifin can modify the drive/motor for higher I/O input voltage.	

Table 6 Direction Input Specifications

Shutdown Input

You can use the shutdown input to shutdown, or disable, the Integral E drive/motor. To activate shutdown, apply a positive voltage to **SHUTDOWN+** with respect to **SHUTDOWN-** when the motor is not moving. During shutdown, the drive turns off current to the motor. The current stays off as long as the voltage is maintained on the shutdown input.

When you remove the voltage on the input, shutdown ends. The drive restores current to the motor, in the same phase relationship that existed before shutdown was invoked.

The shutdown input may also be driven differentially.

Table 7 contains the shutdown input terminal specifications.

Shutdown Input Specifications	
Input Current	2.5 mA minimum
	30 mA maximum
Input Voltage	3.5V minimum (min. required for on or high signal)
	13V maximum
	5V maximum reverse voltage
Active Level	While voltage is applied, current to motor is shut down. When voltage is removed, normal operations resume.
Time	250 nanosecond minimum width
Optically Isolated	Yes

Table 7 Shutdown Input Specifications

Fault Output

The fault output is an open-collector (C), open-emitter (E) output from an OPTO isolator. **FAULT+** is the open-collector output and **FAULT-** is the open-emitter output. The output transistor conducts when the drive is functioning properly. The transistor does not conduct when any of the following conditions exist:

- No power is applied to the drive.
- There is insufficient voltage (<24 VDC).
- The drive detects a motor fault.
- The shutdown input is enabled.

The fault output has the following electrical characteristics:

- $BV_{CEO} = 30V$
- $V_{CE\ sat} = 1.0V$ maximum
- Collector current = 30 mA maximum
- Maximum power dissipation = 75 mW per transistor (2 per SOIC-8 package)

Making the Controller Connections

After reviewing the previous input and output connection descriptions, connect your controller using one of two methods:

1. Separate cables for I/O and DC power conductors (1 two-conductor cable and 1 eight-conductor cable)
2. A shared cable for I/O and DC power conductors (1 ten-conductor cable)

Figure 13 below and Figure 14 on page 24 illustrate these methods. The connection in Figure 13 has been found to meet the requirements of the EMC directive when installed as shown with cables terminated at the drive/motor and the system enclosure. The connection in Figure 14 is typical, but may not meet EMC requirements. (For EMC installation guidelines, see “Appendix A Regulatory Compliance: UL and CE.”)

Notes:

- All I/O connections require twisted-pair wiring.
- R-clamps are useful for cable strain relief as well as RF termination.
- Connector pinout tables for compatible Parker controllers and breakout boxes appear on pages 25 through 27. For more information, see Figure 23 Integral E I/O Circuit Schematic on page 44.

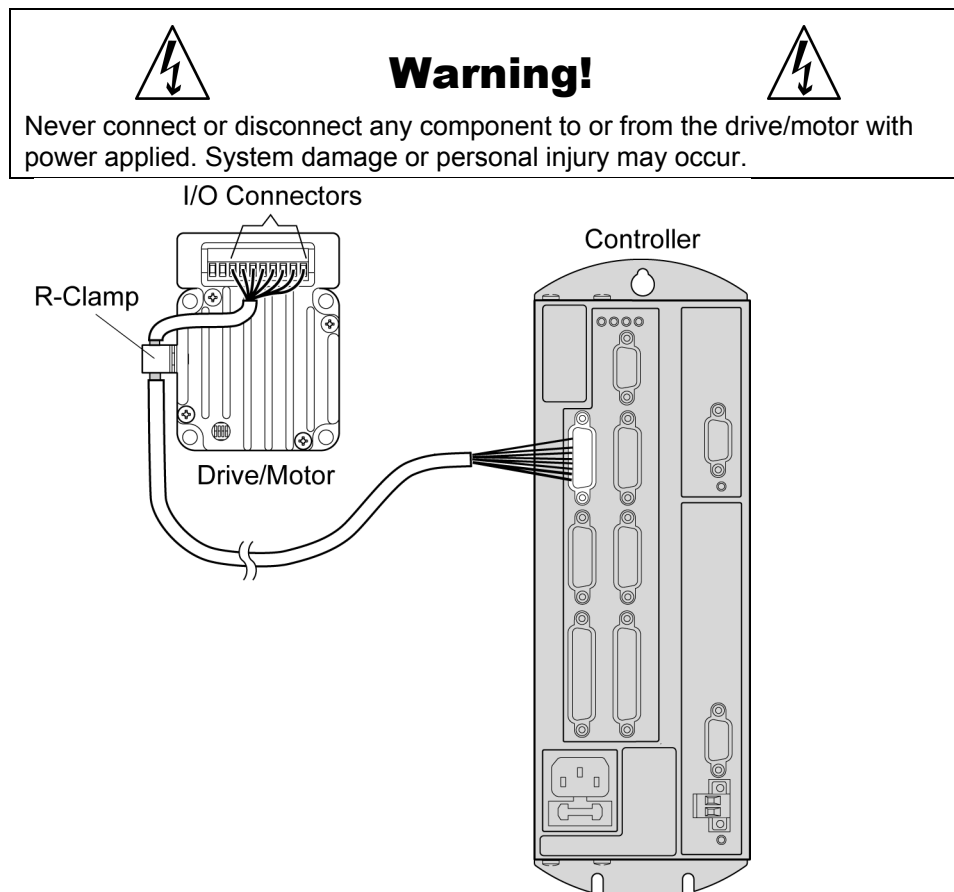

Figure 13 Controller Connections, Separate Cable

Note: Parker Hannifin sells the type of controller cable shown in Figure 13.

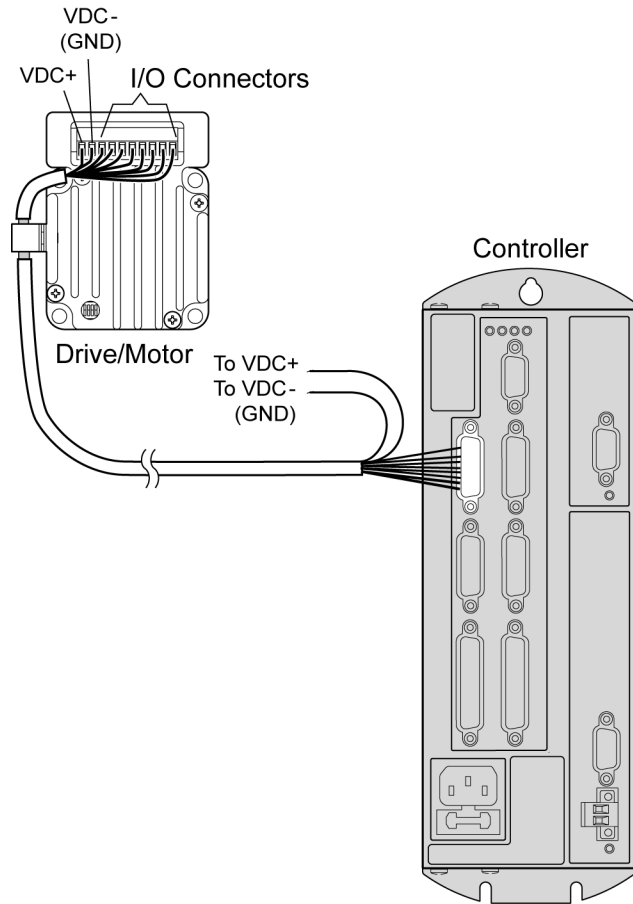

Figure 14 Controller Connections, Shared Cable

Note: Parker Hannifin does not sell the type of cable shown in Figure 14. .

I/O Connector Pinouts

Table 8 through Table 10 contains information for connecting the Integral E Integrated Drive/Motor to compatible controllers. These connectors and breakout boxes are:

- 6K Motion Controllers
- RBC Breakout Box (for ACR2000, ACR8010, ACR8020)
- ACR9000/RBC 1505 Breakout Box (for ACR1505, ACR9000)

6K Controller

Table 8 shows the pinout for the 6K controller's I/O connector.

Integral E Drive/Motor		6K Controller		Cable 71-017003-xx
Signal	Pin	Pin	Signal	Color
DC Power +	1			
DC Power –	2			
Step +	3	1	Step +	Tan
Step –	4	9	Step –	Pink
Direction +	5	2	Direction +	Black
Direction –	6	10	Direction –	White
Enable +	7	11	Shutdown +	Orange
Enable –	8	12	Shutdown –	Violet
Fault + (C)	9	5	DFT	Green
Fault – (E)	10	13	ISO Gnd	White

Note: A box surrounding pins indicates a requirement for twisted-pair wiring.

Table 8 6K Controller Connector Pinout

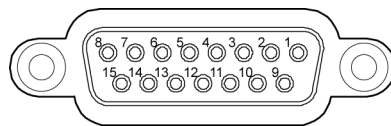

Figure 15 6K Controller Connector

RBC Breakout Box

The following pinout is for the RBC Breakout Box's connector. The RBC Breakout Box serves to connect the following controllers with the Integral E:

- ACR2000
- ACR8010
- ACR8020

Integral E Drive/Motor		RBC Breakout Box		Cable 71-022344-xx
Signal	Pin	Pin	Signal	Color
DC Power +	1			
DC Power –	2			
Step +	3	10	+ 5 VDC	Orange
Step –	4	11	Step +	Violet
Direction +	5	12	+ 5 VDC	Tan
Direction –	6	13	Direction +	Pink
Enable +	7	9	+ 5 VDC	Blue
Enable –	8	21	Enable +	White
Fault + (C)	9	18	+ 5 VDC	Orange
Fault – (E)	10	17	Fault +	Blue

Note: A box surrounding pins indicates a requirement for twisted-pair wiring.

Table 9 RBC Breakout Box Connector Pinout

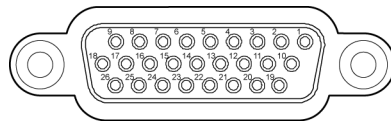

Figure 16 RBC Breakout Box Connector

ACR9000/RBC 1505 Breakout Box

The following pinout is for the RBC 1505 breakout box and ACR9000 I/O connector. The RBC 1505 breakout box and ACR9000 hardware serve to connect the following controllers with the Integral E:

- ACR1505
- ACR9000

Integral E Drive/Motor		ACR9000/RBC 1505 Breakout Box		Cable 71-022344-xx
Signal	Pin	Pin	Signal	Color
DC Power +	1			
DC Power –	2			
Step +	3	10	Step +	Orange
Step –	4	11	Step –	Violet
Direction +	5	12	Direction +	Tan
Direction –	6	13	Direction –	Pink
Enable +	7	9	+ 5 VDC	Blue
Enable –	8	21	Enable +	White
Fault + (C)	9	18	+ 5 VDC	Orange
Fault – (E)	10	16	Fault +	Yellow
Note: In the breakout box the following pins are jumpered: 19 & 20 2 & 24				
Note: A box surrounding pins indicates a requirement for twisted-pair wiring.				

Table 10 ACR9000/RBC 1505 Breakout Box Connector Pinout

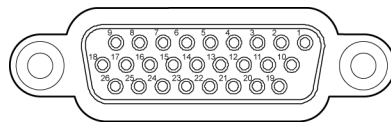

Figure 17 ACR9000/RBC 1505 Breakout Box Connector

3. Mount the Drive/Motor

The Integral E is designed for a minimum-mounting-area configuration. Use flange bolts to mount this rotary step motor. Mount the face flange (NEMA 23 frame) to a large thermal mass, such as a thick steel or aluminum plate that is unpainted, clean, and flat. The *pilot*, or centering flange on the drive/motor's front face, should fit snugly in the pilot hole. Mount the drive/motor so that the heatsink fins are vertical.

Do not use a foot-mount or cradle configuration because the drive/motor's torque is not evenly distributed around the drive/motor case. When a foot mount is used, for example, any radial load on the motor shaft is multiplied by a much longer lever arm.

Step motors can produce very high torques and accelerations. If the mounting is inadequate, this combination of high torque/high acceleration can shear shafts and mounting hardware. Because of the shock and vibration that high accelerations can produce, you may need heavier mounting hardware than for static loads of the same magnitude.

Under certain move profiles, the drive/motor can produce low-frequency vibrations in the mounting structure that can cause fatigue in structural members. A mechanical engineer should check the machine design to ensure that the mounting structure is adequate.



Warning!



Improper drive/motor mounting can jeopardize personal safety, and compromise system performance.

Drive/Motor Modifications

Modifying or machining the motor shaft voids the warranty. Contact a Parker Hannifin Applications Engineer about shaft modifications as a custom product. For contact information, see "Technical Assistance" on page ii.

Drive/Motor Dimensions

There are three models of the Integral E Integrated Drive/Motor, which vary in torque and dimensions. Figure 18 provides the dimensions of each model.

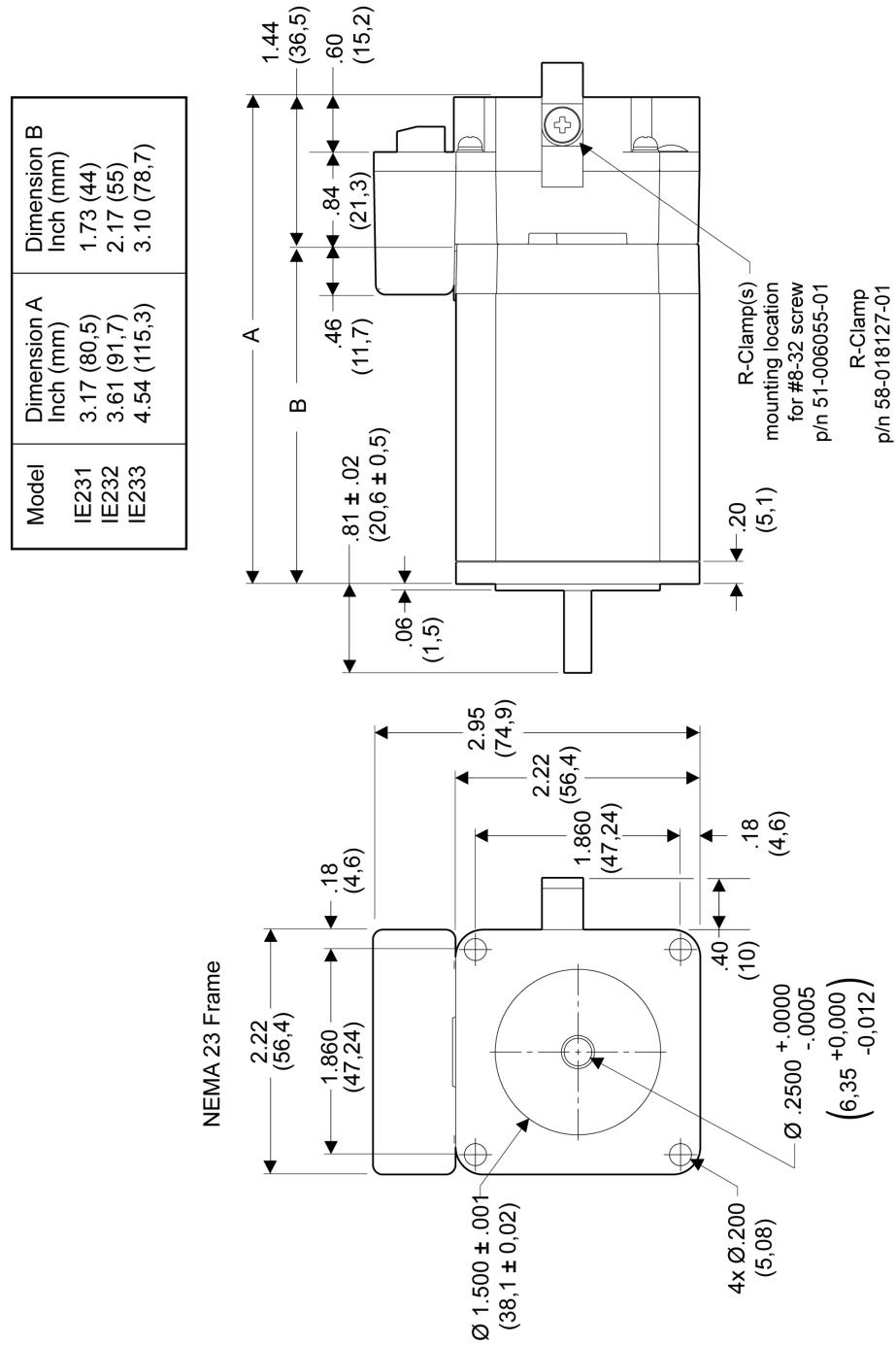

Figure 18 Drive/Motor Dimensions

Mounting Clearance

Follow the minimum spacing and clearance requirements shown in Figure 19 when mounting the Integral E Integrated Drive/Motor. This ensures proper clearance and aids cooling of the unit.

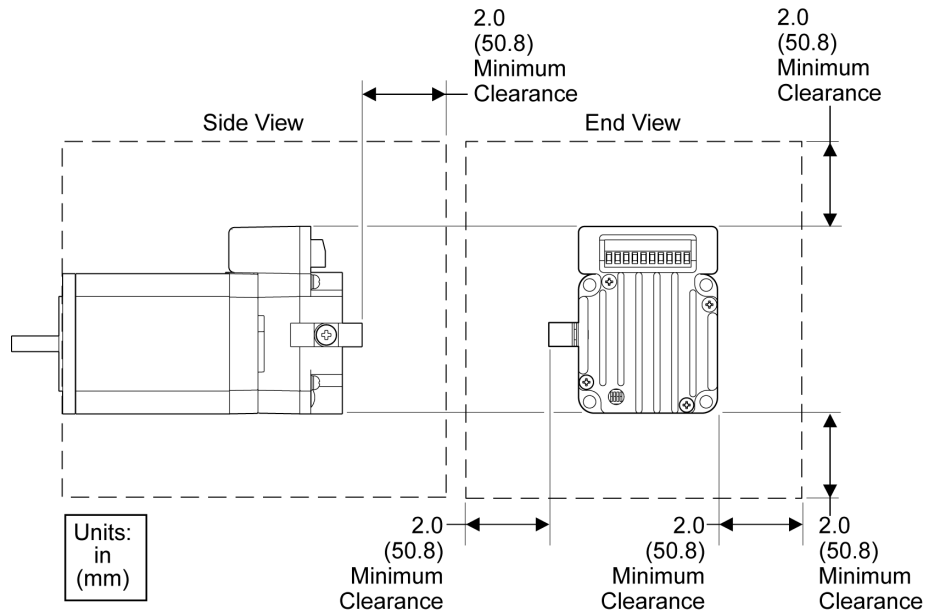

Figure 19 Drive/Motor Panel Layout Dimensions

Environmental Specifications and Considerations

This section covers environmental requirements for the Integral E, such as thermal conditions, humidity, liquids, and airborne contaminants.

	Environmental Specifications
Ambient Temperature	0°C to 40°C (32°F to 104°F)
Overtemperature Shutdown Fault	70°C (158°F) internal ambient
Storage Temperature	-40°C to 80°C (-40°F to 176°F)
Humidity	0 to 95%, non-condensing
Drive/Motor Weight	
IE231	1.3 lbs (0.59 Kg)
IE232	1.8 lbs (0.82 Kg)
IE233	2.6 lb (1.19 Kg)

Table 11 Environmental Specifications

Drive/Motor Heatsinking and Cooling

The drive/motor's face flange is a heatsink as well as a mounting mechanism. Mount the face flange to a large thermal mass, such as a thick steel or aluminum plate that is unpainted, clean, and flat. The *pilot*, or centering flange on the drive/motor's front face, should fit snugly in the pilot hole. Heat is conducted from inside the integrated drive/motor, through the face flange, and dissipated in the thermal mass, thereby cooling the device. For proper heatsinking, the unit must be mounted so that the heatsink fins are vertical.

Operating the integrated drive/motor in high ambient temperatures may require fan cooling to keep the drive/motor from shutting down due to an overtemperature fault.

Overtemperature Shutdown Fault

The integrated drive/motor has an internal thermal sensor that shuts down the drive when the internal temperature reaches 70°C.

Once the Integral E shuts down due to overtemperature, it does not re-enable itself or respond to step pulse until the drive cools below the thermal trip threshold and you perform one of the two following activities:

- Reset the drive/motor by cycling the DC power.
- Energize the drive shutdown input (effectively resetting the latched thermal fault).

Humidity

Keep the relative humidity below 95%, non-condensing.

Liquids

Do not allow liquids or fluids to come into contact with the Integral E drive/motor or its cables or damage may result. The Integral E Integrated Drive/Motor is not sealed.

Airborne Contaminants

Particulate contaminants, especially electrically conductive material such as metal shavings or grinding dust, can damage the integrated drive/motor. Do not allow contaminants to come into contact with it.

4. Connect the Drive/Motor to the Load

Align the motor shaft and load as accurately as possible. In most applications, some misalignment is unavoidable, due to tolerance buildups in components. However, excessive misalignment may degrade your system's performance. The three misalignment conditions, which can exist in any combination, are illustrated in Figure 20 and described on the following page.

Load Misalignment Conditions

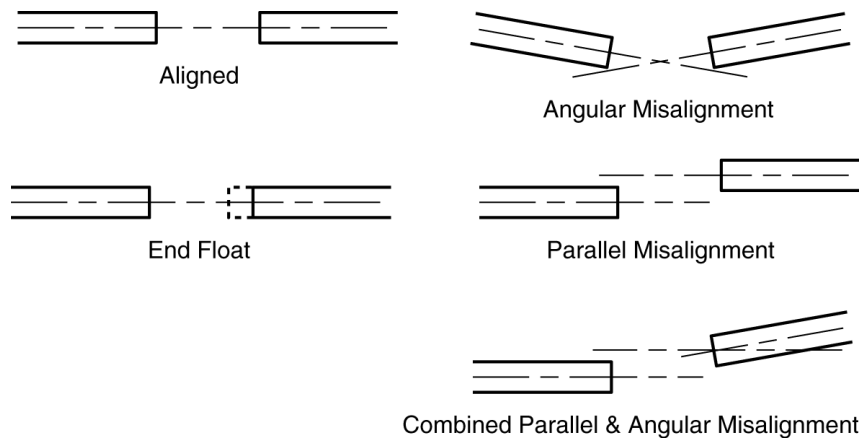

Figure 20 Load Misalignment Conditions

- **Angular Misalignment:** The center lines of two shafts intersect at an angle other than zero degrees.
- **Parallel Misalignment:** The offset of two mating shaft center lines, although the center lines remain parallel to each other.
- **End Float:** A change in the relative distance between the ends of two shafts.

The type of misalignment in your system affects your choice of coupler.

Single-Flex Coupling

Use a single-flex coupling when you have angular misalignment only. Because a single-flex coupling is like a hinge, one and only one of the shafts must be free to move in the radial direction without constraint. Do not use a double-flex coupling in this situation: it will allow too much freedom and the shaft will rotate eccentrically, which will cause large vibrations and catastrophic failure. Do not use a single-flex coupling with a parallel misalignment: this will bend the shafts, causing excessive bearing loads and premature failure.

Double-Flex Coupling

Use a double-flex coupling whenever two shafts are joined with parallel misalignment, or a combination of angular and parallel misalignment (the most common situation).

Single-flex and double-flex couplings may or may not accept end play, depending on their design.

Rigid Coupling

Rigid couplings are generally not recommended, because they cannot compensate for any misalignment. They should be used only if the drive/motor or load is on some form of floating mounts that allow for alignment compensation.

Rigid couplings can also be used when the load is supported entirely by the drive/motor's bearings. A small mirror connected to a motor shaft is an example of such an application.

Coupling Manufacturers

HUCO Engineering
Industries
Mooney Industrials, Inc.
(distributor)
123 Carlos Drive
San Rafael, CA 94903
(415) 492 0278
www.huco.com

Rocom Corp.
5957 Engineer Drive
Huntington Beach, CA
92649
(714) 891-9922
www.rocomcorp.com

HELICAL Products Co.
901 W. McCoy Lane
Santa Maria, CA 93456
(805) 928-3851
www.heli-cal.com

5. Connect a DC Power Supply

At this point in your permanent installation procedure, you should have mounted your drive/motor, coupled the motor shaft to the load, and connected the controller cables to the drive/motor. .

Use one of two methods to connect a DC power supply to the drive/motor:

- 1 two-conductor cable, separate from the controller I/O cable.
- two conductors of a ten-conductor cable shared with the controller I/O connections.

Figure 21 and Figure 22 illustrate these two methods of connection. (For complete EMC installation requirements, see “Appendix A Regulatory Compliance: UL and CE”.)

To make the connection

1. Connect the cable/conductors on one end to the drive/motor’s VDC+ (position 1) and VDC– (position2) connectors.
2. Connect the cable/conductors on the other end to the corresponding connectors of a 24 VDC to 48 VDC power supply.

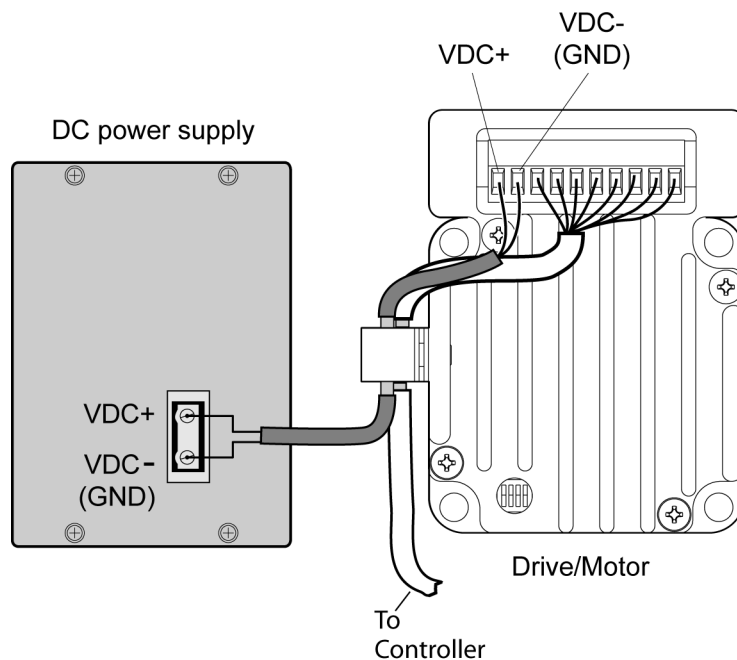

Figure 21 DC Power Supply Connection, Separate Cable

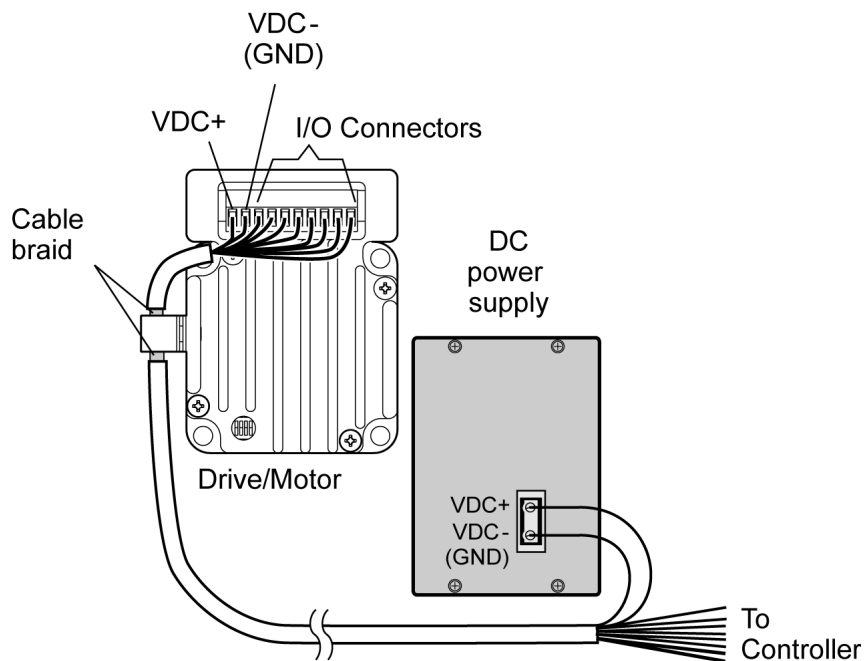

Figure 22 DC Power Supply Connection, Shared Cable



Warning!



Do not reverse VDC+ and VDC-. Reversing these connections can seriously damage the drive.

Applying Power

The Integral E *does not* have an on/off switch. When you apply power to the drive/motor, the drive/motor turns on. Therefore, before you apply power, verify the following:

- The drive/motor is properly secured.
- The drive/motor is properly mounted.
- The controller cable is connected to drive/motor.
- Automatic test is disabled.

Choosing a Power Supply

The Integral E operates from a regulated or unregulated DC supply. It is important to choose a supply that operates reliably with the Integral E. A regulated supply must be capable of handling a large peak load and remaining stable in the presence of a regenerating load. In an unregulated supply, the unloaded voltage must not exceed the maximum voltage rating of the Integral E (50V).



Warning!



The Integral E operates in the range of 24 VDC to 48 VDC (-10%, +5%). Voltage above 50 Volts may damage the unit.

The drive/motor has internal protection for a limited regenerative load, but it does not provide over-voltage protection from a poorly regulated supply.

Peak Power Ratings

Table 12 contains peak power ratings for the Integral E to help you choose a power supply. Parker Hannifin recommends using the power supplies in Table 2 Integral E Drive/Motor Accessories on page 2.

Drive/Motor	Voltage (VDC)	Peak Power Speed (RPS)	Torque (Oz-In)	Power Input (Watts)	Motor Current (Amps)	Shaft Power (Watts)	Drive Losses (Watts)
IE231	24	10	48	38.8	1.65	21.29	17.51
IE231	48	19	42	64.6	1.36	35.40	29.20
IE232	24	3	128	38.7	1.65	17.03	21.67
IE232	48	8	112	68.3	1.44	39.75	28.55
IE233	24	2	210	44.6	1.9	18.63	25.97
IE233	48	7	158	76.3	1.6	49.06	27.24

Table 12 Peak Power Ratings

Conversions

Use the following formulas to convert values in watts to the desired units of measurement.

- To convert Watts to horsepower, divide by 746
- To convert Watts to BTU/hour, multiply by 3.413
- To convert Watts to BTU/minute, multiply by 0.0569

Power Supply Requirements

The Integral E operates from an external DC power supply in the range of 24 VDC to 48 VDC (-10%, +5%). The unit draws the minimum current shown in Table 13 when the motor is not delivering shaft power.

Current Draw from DC Power Supply (No Shaft Power)			
Voltage	Enabled without Standby	Enabled with Standby	Shutdown
24	1.01 Amps	0.244 Amps	0.053 Amps
48	0.545 Amps	0.185 Amps	0.035 Amps

Table 13 Current Draw from DC Power Supply

Drive/Motor Type

Consult Parker Hannifin's Applications Engineering Department for assistance with a custom winding. For contact information, see "Technical Assistance" on page ii.

3. Test the Installation

System installation should be complete at this point. Perform the test procedure below to verify that your system is functioning properly. In the test procedure, you will command single revolution moves in the clockwise and counterclockwise direction. If your mechanics do not permit such moves, choose a move that allows you to easily verify correct system response.

Test Procedure

1. Apply DC power.
2. Command a slow move of one revolution in the clockwise direction.
3. Verify that the motor turns as commanded.
4. Command a slow move of one revolution in the counterclockwise direction.
5. Verify that the motor turns as commanded.

Successful completion of this procedure will verify that your controller and drive/motor are connected correctly, and that the drive/motor is functioning properly.

If the test is unsuccessful, proceed to "Chapter 3 Troubleshooting" for problem identification and solution procedures.

Motor Performance

Table 14 provides performance specifications for the drive/motor.

	Performance Specifications
Accuracy	±10.0 arcminutes typical (unloaded, bidirectional)
Repeatability	±5 arcseconds typical (unloaded, bidirectional)
Hysteresis	Less than 2 arcminutes—0.0334° (unloaded, bidirectional)

Table 14 Motor Performance Specifications

CHAPTER THREE

Troubleshooting

IN THIS CHAPTER

• Troubleshooting Basics	39
• Protective Circuits	39
• Testing the Unit	39
• Reducing Electrical Noise	40
• Maintenance	40
• Common Problems and Solutions.....	41
• Technical Support	42

Troubleshooting Basics

When your system does not function properly (or as you expect it to operate), the first thing that you must do is identify and isolate the problem. When you have accomplished this, you can effectively begin to resolve the problem.

The first step is to isolate each system component and ensure that each component functions properly when it is run independently. You may have to dismantle your system and put it back together piece by piece to isolate the problem. If you have additional units available, you may want to exchange them with existing components in your system to help identify the source of the problem.

Determine if the problem is mechanical, electrical, or software-related. Can you repeat or recreate the problem? Random events may appear to be related, but they are not necessarily contributing factors to your problem.

You may be experiencing more than one problem. You must isolate and solve one problem at a time. Log (document) all testing and problem isolation procedures. You may need to review and consult these notes later. This will also prevent you from duplicating your testing efforts.

Use the troubleshooting procedures and solutions contained in this chapter to isolate and resolve any problems.

Protective Circuits

Two types of circuits designed to protect the motor/drive from damage effectively shut down the unit if specific conditions are present. Remedy the conditions and restore functionality to the unit as described in this section.

Overtemperature Protection

To protect against damage from high temperatures, the drive/motor has an internal thermal sensor. If the sensor detects an internal ambient temperature of 70°C (158°F), it triggers an overtemperature fault. The drive/motor shuts down. This is a latched fault.

Once the Integral E shuts down due to overtemperature, it does not re-enable itself or respond to step pulse until the drive cools below the thermal trip threshold and you perform one of the two following activities:

- Reset the drive/motor by cycling the DC power.
- Energize the drive shutdown input (effectively resetting the latched thermal fault).

Short Circuit Protection

The Integral E is protected against phase-to-phase and phase-to-ground short circuits. When the drive detects a short circuit in the motor or motor cabling, it stops producing motor current. This is a latched condition.

Verify that the condition is not an overtemperature fault using the following steps:

1. Remove power from the drive/motor.
2. Verify that the operating temperature is below the overtemperature limit.

3. Cycle power to the drive/motor.

If these steps do not correct the problem, you must return the drive/motor for service.

Note: The Integral E Integrated Drive/Motor has no internal user-serviceable parts. If a problem develops with an internal motor wire, you must return the unit for service. For contact information, see “Technical Assistance” on the inside cover, page ii.

Testing the Unit

In diagnosing a problem, it is helpful to rule out possible causes. If you disconnect the load and controller from the drive/motor, two components remain—the drive/motor itself and the power cable.

You can then configure the drive/motor to run the automatic test function. For instructions, see “Automatic Test” on page 10. If the motor turns as expected—in an alternating mode—then the drive/motor and power cable are probably not the cause of the problem. The cause may lie with the controller, software, mechanics, or the controller-to-motor cable, etc.

Reducing Electrical Noise

For detailed information on reducing electrical noise in your system, refer to “Appendix A Regulatory Compliance: UL and CE.”

Maintenance

Ensure that the drive/motor's heatsink has proper clearance and ventilation. All earth ground connections must be continuous and permanent.

Inspect the drive/motor regularly to ensure that no mounting screws, bolts, or couplings have become loose during normal operation. This prevents minor problems from developing into problems that are more serious. Inspect the motor cable periodically for signs of wear. This inspection interval is duty-cycle, environment, and travel-length dependent. The cable should not have excessive tensile force applied to it and should not be bent beyond a one-inch radius of curvature during normal operation. Tighten any cable connectors.

Common Problems and Solutions

Use Table 15 to help you solve problems you might have with the Integral E Integrated Drive/Motor.

Symptom	Probable Causes	Solutions
Drive/motor loses pulses at high speeds	Controller is overdriving step input	Verify that the step input current is not greater than 15 mA.
	Controller is underdriving step input	Verify that the step input current is greater than 6.8 mA.
	Controller is sending pulses too fast	Verify that the controller is not exceeding the 1.5 MHz maximum pulse rate.
	Motor is out of torque at speed	Verify that the motor is sized correctly for your application.
Drive/motor stalls at high speeds	The velocity is too high	The drive can handle a maximum of 1.5 MHz pulse rate or 50 rps, whichever comes first; decrease the velocity.
	Motor is undersized for application	Verify that the motor is sized correctly for your application.
Drive/motor stalls during acceleration	The acceleration is set too high	Decrease the acceleration.
	There is insufficient rotor inertia	Use a larger motor.
	Motor is undersized for application	Verify that the motor is sized correctly for your application.
Drive/motor (unloaded) stalls at nominal speed	There is insufficient rotor inertia	Use a larger motor.
	Mid-frequency resonance	Adjust the speed of the motor.
Drive/motor does not move commanded distance	Motor resolution is set incorrectly	Determine the resolution on your controller and verify that the drive resolution setting is the same.
Drive/motor does not change direction as commanded	The direction input is not being enabled	Verify that the direction input is being enabled (6.8 mA to 15 mA).
Controller moves motor in wrong direction	There is a direction conflict within the controller	Change controller, or if direction is driven differentially, swap the Direction+ and Direction- connections on the drive/motor.
There is little or no holding torque	Automatic standby function is enabled	Set DIP switch 1 to the off position or check shut down connection.
Drive/motor moves erratically at low speeds	Controller pulses are being sent to the drive erratically	Verify with an oscilloscope that the controller pulses are being sent at a constant rate and are not being frequency modulated.

Table 15 Common Problems and Solutions

Technical Support

If you cannot solve your system problems using this documentation, contact your local Automation Technology Center (ATC) or distributor for assistance. If you need to talk to our in-house application engineers, contact Parker Hannifin's Applications Department. For contact information see "Technical Assistance" on the inside cover, page ii.

CHAPTER FOUR

Schematic

IN THIS CHAPTER

- Integral E I/O Circuit Schematic 44

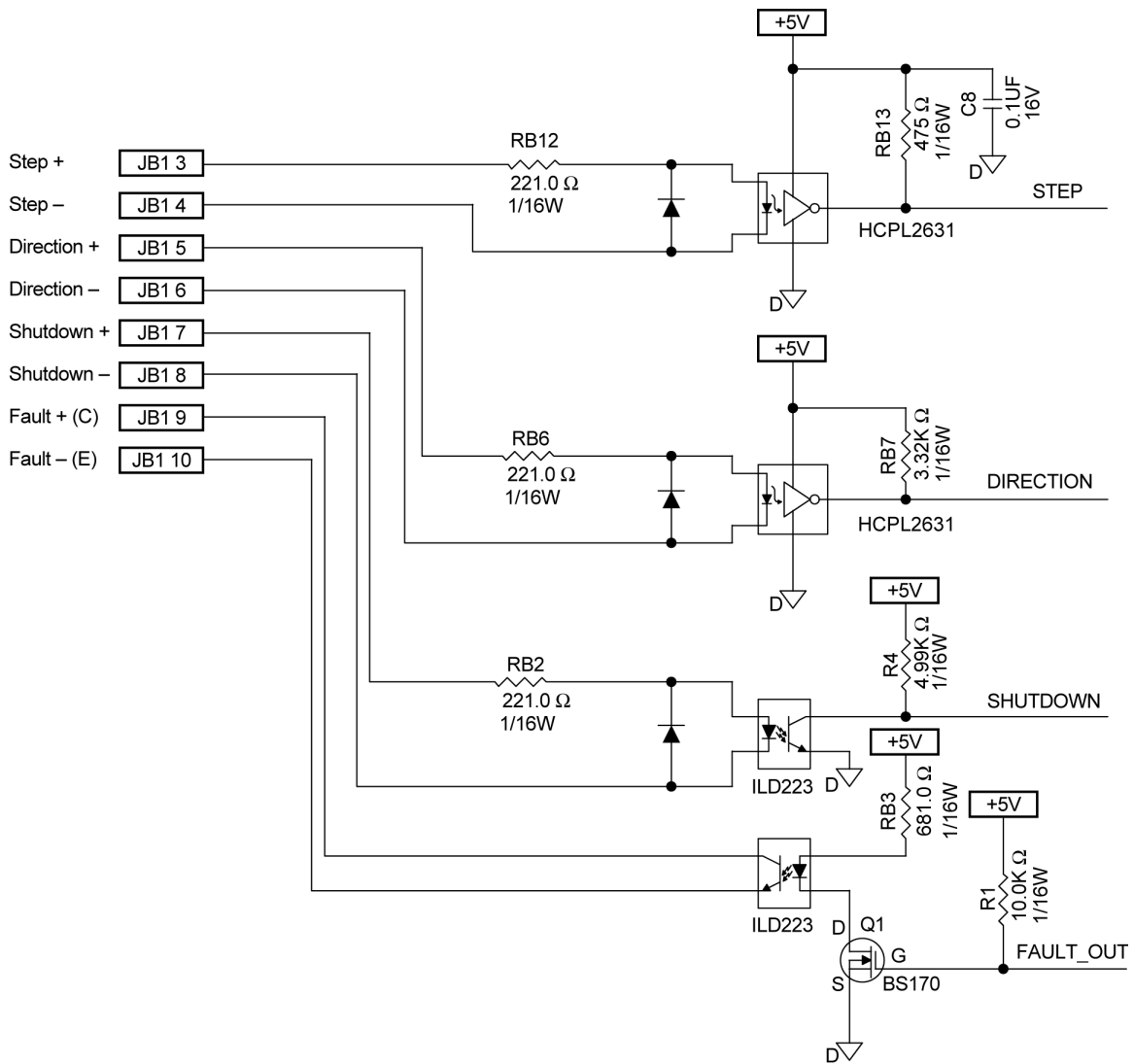

Figure 23 Integral E I/O Circuit Schematic

APPENDIX A

Regulatory Compliance: UL and CE

IN THIS CHAPTER

- System Installation Overview 46
- General Safety Considerations 46
- General EMC Considerations 46
- Installing the Integral E Integrated Drive/Motor..... 47
- Regulatory Agencies 54
- Standards of Compliance..... 54

System Installation Overview

This appendix contains information related to installation methods and practices that can be used to aid the systems integrator or machine builder in designing a compliant installation, meeting the needs of Global Regulatory Agencies.

The installation overview is divided in to two sections—“Safety” and “Electromagnetic Compatibility (or EMC)”.

It is recommended that the installer read this entire overview, prior to taking any action, as some of the required installation methods can be leveraged across both Safety and EMC installations.

Although the Integral E Integrated Drive/Motor is technically considered a motion control component and is therefore not within the scope of the European Union’s CE (Conformité Européenne) directives, Parker Hannifin has taken the initiative to provide its customers with easy-to-integrate motion control products that meet global requirements.

The following constitutes what is typically required to install the Integral E into a CE compliant system. Additional installation measures may be required at some locations. The machine builder has ultimate responsibility for machine compliance.

General Safety Considerations

These products are intended for installation according to the appropriate safety procedures, including those laid down by the local supply authority regulations. The recommendations provided are based on the requirements of the Low Voltage Directive and specifically on EN61010. Remember, never compromise safety to achieve EMC compliance. Therefore, in the event of a conflict between safety regulations and the following EMC recommendations, safety regulations always take precedence.

General EMC Considerations

The Integral E product is a Motion Control Component and as such will be built in to another machine that will in turn be required to comply with the relevant directives of the marketplace.

It is important to remember that for specific installations, the full protection requirements of the EMC directive 89/336/EEC need to be met before the system is taken in to service. This must be verified either by inspection or by testing. The following EMC installation recommendations are intended to assist in ensuring that the requirements of the EMC directive are met. It may be necessary to take additional measures in certain circumstances and at specific locations.

It should be stressed that although these recommendations are based on the expertise acquired during the design and development of the Integral E product family, and on tests carried out on similar products, it is impossible for Parker Hannifin to guarantee compliance of any particular installation. This will be strongly influenced by the physical and electrical details of the installation and the performance of other system components. Nevertheless, it is important to follow all the installation recommendations if an adequate level of compliance is to be achieved.

Installing the Integral E Integrated Drive/Motor

Only qualified, skilled electrical technicians familiar with local safety requirements should install this product. For service, the controller must be returned to an authorized service center. There are no user-serviceable parts inside the chassis. In certain circumstances, opening the cover may void the product warranty.

The Integral E is not an environmentally sealed product. To prevent material from spilling into the product, mount it under an overhang or in a suitable enclosure.

Integral E products are made available under “Restricted Distribution” for use in the “Second Environment” as described in EN 61800-3 1996, page 9. This means only those individuals familiar with the EMC requirements of motion control systems should install this product and that this product is designed for connection to mains distribution networks (through appropriately specified DC power supplies) other than low-voltage networks, which may supply domestic premises. The controller can tolerate atmospheric pollution degree 2, which means only dry, non-conductive pollution is acceptable.

The Integral E Integrated Drive/Motor has been shown to meet the requirements of the European EMC (Electromagnetic Compatibility) Directive when installed according to the recommendations given within this section. It is recommended that the drive/motor be installed in such a manner as to protect it from atmospheric and industrial process contaminants and to prevent operator access while it has power applied.

Precautions

During installation, take the normal precautions against damage caused by electrostatic discharges. Wear earth wrist straps.

A Safe Installation – Meeting the Requirements of the Low Voltage Directive (LVD)

The Integral E products operate from DC current provided by an external (user specified and supplied) power supply. This power supply must be chosen such that it conforms to the requirements of the applicable Safety Standards associated with the overall machine, its installation and its end-use environment.

A Highly-Immune, Low-Emission Installation—Meeting the Requirements of the Electromagnetic Compatibility (EMC) Directive

The following information was compiled to aid the machine builder or systems integrator in gaining EMC compliance. For effective control of Conducted and Radiated Emissions, along with maximizing the Integral E Integrated Drive/Motor’s inherent noise immunity, the following recommendations should be observed.

- For EMC compliance, electrical connections to the Integral E must be made using high-quality, braided (minimum 85% coverage) cable. This cable’s shield must be terminated to the body of the Integral E (R-Clamp or equivalent) and to a clean system Earth at the DC power source and controller end. For ESD purposes, these connections must not be accessible under normal operation.

Important!

A typical EMC compliant installation requires housing power supplies and controllers within a properly earth-grounded enclosure. This means that all paint and other non-conductive surface coatings must be removed from the panel mounting surface and RF earth bonding locations.

If you mount the power supply or controller in an equipment cabinet, and have mounted the Integral E external to the cabinet, you must terminate the cable braids (screens) at the entrance of the enclosure. This can be easily accomplished using the “additional EMC installation hardware” shown below.

The shields of all cables connecting to the Integral E that enter or exit the enclosure must be RF bonded to the enclosure entrance point using an R-Clamp, bulkhead clamshell clamp, or other 360° bonding technique. This ensures that no stray noise will enter or exit the enclosure. Figure 24 illustrates 360° bonding techniques.

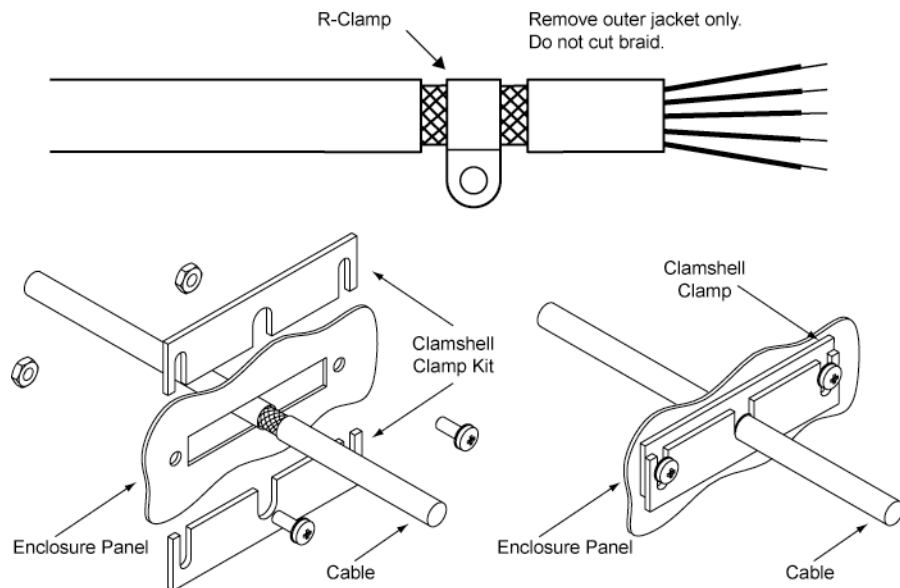

Figure 24 360° Bonding Techniques

All braid termination connections must remain secure. For small diameter cables, it may be necessary to fold back the braid to increase the effective diameter of the cable so that R-Clamps are secure.

Keep high-voltage power cables separate from low voltage signal cables. This applies particularly where long lengths of control cables run close to the cables providing power to motor drives, contactors, relays, etc. In extreme cases (for example, arc welding) it may be necessary to have separate electrical conduits for cables with different functions and power levels.

There must be no break in the 360° coverage that the screen provides around the cable conductors.

A steel equipment cabinet screens radiated emissions, provided all panels are bonded to a central earth point. Separate earth circuits are commonly used within equipment cabinets to minimize the interaction between independent circuits. A circuit switching large currents and sharing a common earth return with another low-level signal circuit could conduct electrical noise into the low level circuit, thereby possibly interfering with its operation. For this reason, so called “dirty earth” and “clean earth” circuits may be formed within the same cabinet, but all such circuits eventually will need to be returned to the cabinet’s main star earth point.

Mount the individual components, power supply, controllers and the EMC filter (if your system requires a filter), on a metal earth plane. The earth plane will have its own individual star point earth that should be hard wired (using an insulated copper conductor) back to the cabinet’s clean earth connection point.

Panel mounting can provide a similar measure of EMC performance if strict attention is paid to cable screen termination and cable layout.

Again, the machine builder’s primary focus should be on ensuring operators are kept safe from all hazards.

- (Optional) Install a Mains filter. If your installation requires a mains filter to meet the conducted emissions requirements, it is recommended that you mount the drive/motor to the metallic earth structure of the machine that is shared with the EMC filter. If the machine structure has a paint finish, you must remove the paint in certain areas to ensure that filters and drive/motor make a good large-area, metal-to-metal contact between the filter case and machine earth.

Conducted emissions testing has shown that the Integral E does not typically require the use of a mains filter to meet the EMC requirements of the European Union when installed with properly terminated braided cables. The filtering action of a linear power supply is adequate to reduce the emission to a compliant level. If additional suppression is necessary, the mains filters in Table 16 on page 50 have been shown to be effective in reducing conducted emissions.

For applications utilizing multiple Integral E products, it is possible to share mains filters between multiple power supplies.

Mains Filter (AC Line Filter)	Filter Rating, Continuous Current (Amps)	Number of Motor/Drives (23 Frame)
3EP1 ¹	3 at 240VAC	1
FN670-3/06 ²	3 at 240VAC	1
6EP1 (160937-5) ¹	5 at 240VAC	2
10EP1 (160937-7) ^{1,3}	8 at 240VAC	3
FN2070-10/06 ²	10 at 240VAC	3
FN2070-12/06 ²	12 at 240VAC	4
FN2070-16/06 ^{2,3}	16 at 240VAC	5

1. Corcom (a division of Tyco Electronics)
2. Schaffner
3. Available filters from Parker Hannifin:
Note: 10 Amp filter—part number 47-016140-01
16 Amp filter—part number 47-017900-01

Table 16 Mains Filter Selection

- Use shielded cabling with RF bonded terminations.

For maximum immunity and minimum emissions, both ends of each cable must be earth-bonded. All connections must be made using a high quality braided-screen cable (with minimum of 85% coverage). Cables using a metalized plastic bandage for an earth screen are unsuitable and in fact provide very little screening. Care must be taken when terminating the cable screen, as the screen itself is comparatively fragile; bending it in a tight radius can seriously affect the screening performance. The selected cable must have a temperature rating that is adequate for the expected operating temperature of the motor case and the environment.

All cables must maintain high-integrity, 360-degree shielding. For differential signals (inputs and outputs), shielded, twisted-pair wiring (with 3 turns per inch (TPI)) is recommended. When you install limit switches and other inputs/outputs, you must observe these noise immunity procedures and practices.

- Route cables as shown in Figure 25 Typical EMC-Compliant Panel Installation on page 53.

Route high power cables (motor and mains) at right angles to low power cables (communications and inputs/outputs). Never route high and low power cables parallel to each other.

If mains filters are required, mount them close to the power entry point in the system cabinet, thus keeping lengths of unfiltered (dirty) power to a minimum. Attempt to layout the wiring in a way that minimizes cross coupling between filtered and non-filtered conductors. This means avoiding running wires from the output of a filter close to those connected to its input. Where you wish to minimize the cross coupling between wires avoid running them side-by-side. If they must cross,

cross them at a 90-degree angle to each other. Keep wiring supported and close to cabinet metalwork.

- Cables may require the use of ferrite core suppressors. Some installations may require that you take additional EMC measures. To further increase product immunity and reduce product emissions, you may add clip-on ferrite absorbers to all cables. Parker Hannifin recommends ferrites with at least 200 ohm impedance at 100 MHz, such as the following:

Steward Ferrite Part number 28A2024

Fair-Rite Part number 0443164151

Note: These ferrites are available from Parker Hannifin, part number 47-015956-01

Ferrite absorbers also are recommended for cable runs longer than 5 meters.

- Your Installation may require additional EMC installation hardware (as shown in various illustrations).

The clamp kits (earth-bonding kits) in Table 17 are available from Parker Hannifin:

Clamp Type	Parker Hannifin Part Number
R-Clamp Kit (10 per)	R CLAMP KIT
Clamshell Clamp Kit*	CLAMSHELL KIT
* The clamshell kit consists of two clamshell clamps.	

Table 17 Enclosure Mounting Clamps

- Parker Hannifin recommends the use of the following varistors on the mains filters.

Littlefuse Part number 275L20

Typical EMC Installation

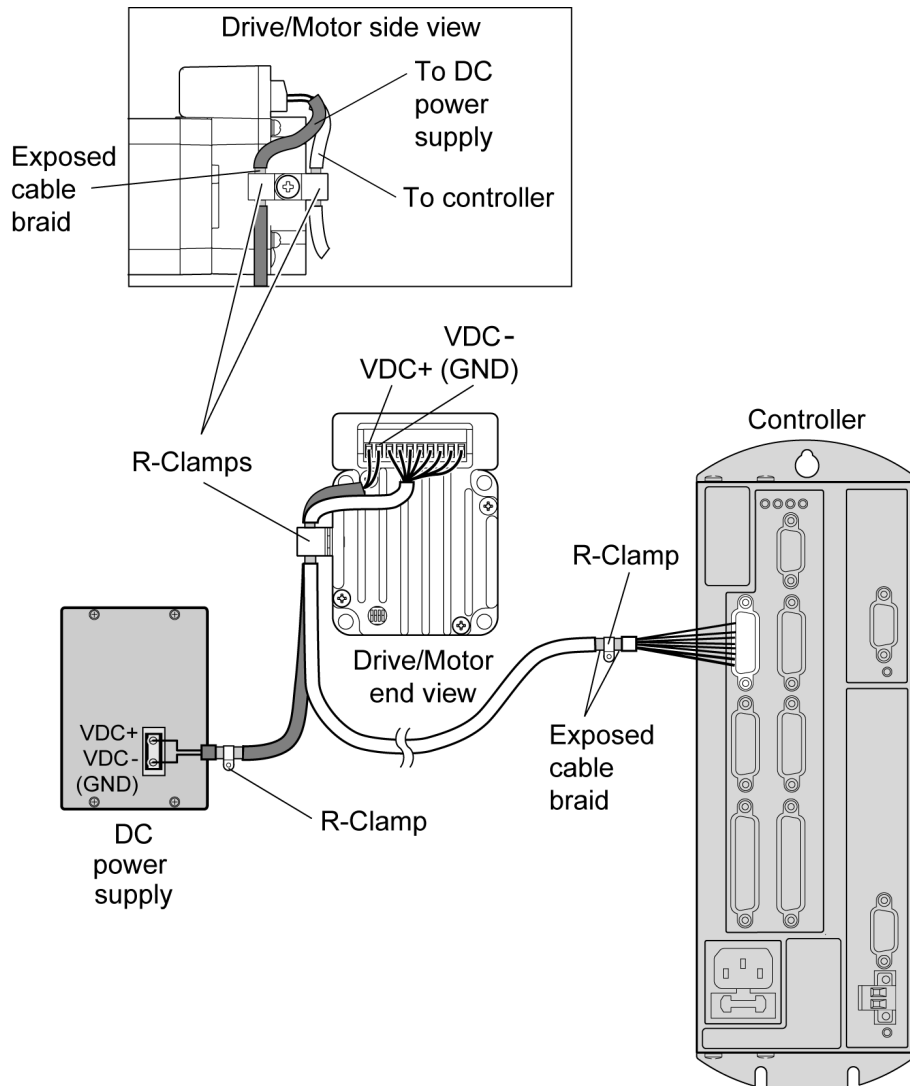

Table 18 Typical EMC Installation

Panel Installation in an Earth-Bonded Metallic Enclosure

Figure 25 shows an installation that employs separate cables for I/O and DC power conductors (1 two-conductor cable and 1 eight-conductor cable), with cables terminated at the Drive/Motor, the earth-bonded enclosure, the controller, and the DC power supply.

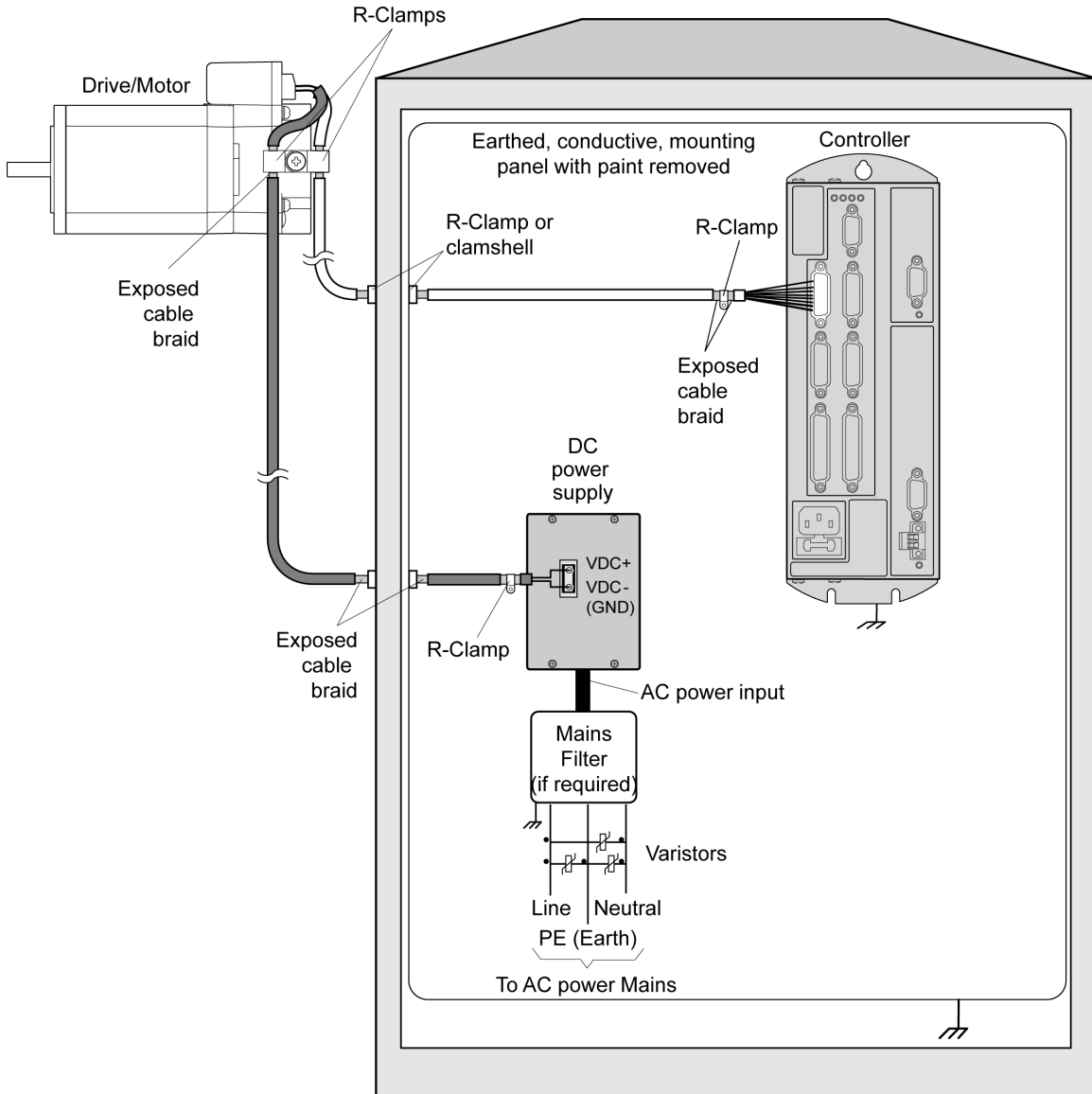

Figure 25 Typical EMC-Compliant Panel Installation

Regulatory Agencies

The Integral E family of products is designed to meet the requirements of global regulatory agencies.

Integral E products have shown compliance with the regulatory agencies in the following list. The list also shows additional steps users must take to ensure compliance.

Agency	Additional Steps User Must Take
UL	None
CE (EMC)	<ul style="list-style-type: none"> • Mains filter (if required) • Braided, terminated cabling • Proper installation (per instructions) • If your installation requires additional transient overvoltage protection, you may wish to install transient suppressors such as varistors between the AC mains and the DC Power Supply providing power to the Integral E. There are no internal transient limiting devices inside the Integral E.

Table 19 Regulatory Agencies

Standards of Compliance

UL	508C	Power conversion equipment standard
CE for EMC	89/336/EEC	
	BS EN 50081-2 (1994) Electromagnetic compatibility	Generic emission standard Part 2. Industrial Environment.
	BS EN 61000-6-2 (1999) Electromagnetic compatibility Part 6-2: Generic Standards	Immunity for industrial environments.
	BS EN 61800-3 (1997) Adjustable speed electrical power drive systems	Part 3 : EMC product standard including specific test methods

APPENDIX B

Specifications

IN THIS CHAPTER

• Environmental Specifications	56
• Mechanical Specifications	59
• Electrical Specifications	62
• External I/O Connectors	64
• DIP Switches	68

This appendix is a quick reference to the Integral E specifications that appear throughout the manual.

Environmental Specifications

Table 20 contains the general environmental specifications for the Integral E Integrated Drive/Motor.

	Environmental Specifications
Ambient Temperature	0°C to 40°C (32°F to 104°F)
Overtemperature Shutdown Fault	70°C (158°F) internal ambient
Storage Temperature	-40°C to 80°C (-40°F to 176°F)
Humidity	0 to 95%, non-condensing
Drive/Motor Weight	
IE231	1.3 lbs (0.59 Kg)
IE232	1.8 lbs (0.82 Kg)
IE233	2.6 lb (1.19 Kg)

Table 20 Environmental Specifications

Heatsinking

The drive/motor's face flange is a heatsink as well as a mounting mechanism. Mount the face flange to a large thermal mass, such as a thick steel or aluminum plate that is unpainted, clean, and flat. The *pilot*, or centering flange on the drive/motor's front face, should fit snugly in the pilot hole. Heat is conducted from inside the integrated drive/motor, through the face flange, and dissipated in the thermal mass, thereby cooling the device. For proper heating, the unit must be mounted so that the heatsink fins are vertical.

Cooling and Temperature

When mounting the Integral E Integrated Drive/Motor, follow the minimum spacing and clearance requirements shown in Figure 26 on page 57. This ensures proper clearance and aids in cooling of the unit.

Mounting Clearance

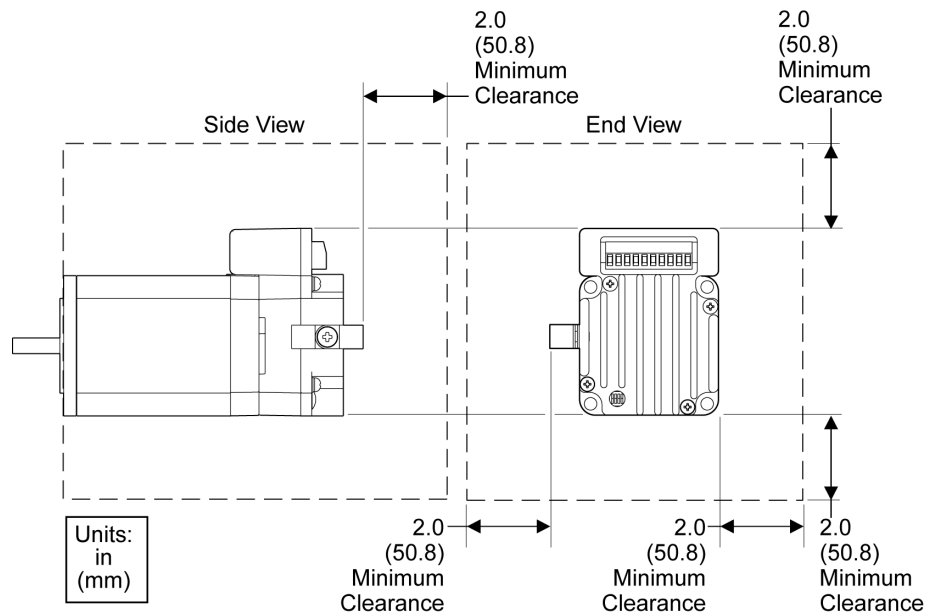

Figure 26 Panel Layout Requirements

Operating the integrated drive/motor in high ambient temperatures may require fan cooling to keep the drive/motor from shutting down due to an overtemperature fault.

Overtemperature Shutdown Fault

To protect against damage from high temperatures, the drive/motor has an internal thermal sensor. If the sensor detects an internal ambient temperature of 70°C (158°F), it triggers an overtemperature fault that shuts down the drive/motor. This is a latched fault.

Once the Integral E shuts down due to overtemperature, it does not re-enable itself or respond to step pulse until the drive cools below the thermal trip threshold and you perform one of the two following activities:

- Reset the drive/motor by cycling the DC power.
- Energize the drive shutdown input (effectively resetting the latched thermal fault).

Humidity

Keep the relative humidity below 95%, non-condensing.

Liquids

Do not allow liquids or fluids to come into contact with the Integral E drive/motor or its cables or damage may result. The Integral E Integrated Drive/Motor is not sealed.

Airborne Contaminants

Particulate contaminants, especially electrically conductive material such as metal shavings or grinding dust, can damage the integrated drive/motor. Do not allow contaminants to come into contact with it.

Mechanical Specifications

Drive/Motor Dimensions

There are three models of the Integral E Integrated Drive/Motor, which vary in torque and dimensions: IE231, IE232, and IE233. Figure 27 provides the dimensions of each model. The motor flange is a standard NEMA 23 size frame.

Model	Dimension A Inch (mm)	Dimension B Inch (mm)
IE231	3.17 (80,5)	1.73 (44)
IE232	3.61 (91,7)	2.17 (55)
IE233	4.54 (115,3)	3.10 (78,7)

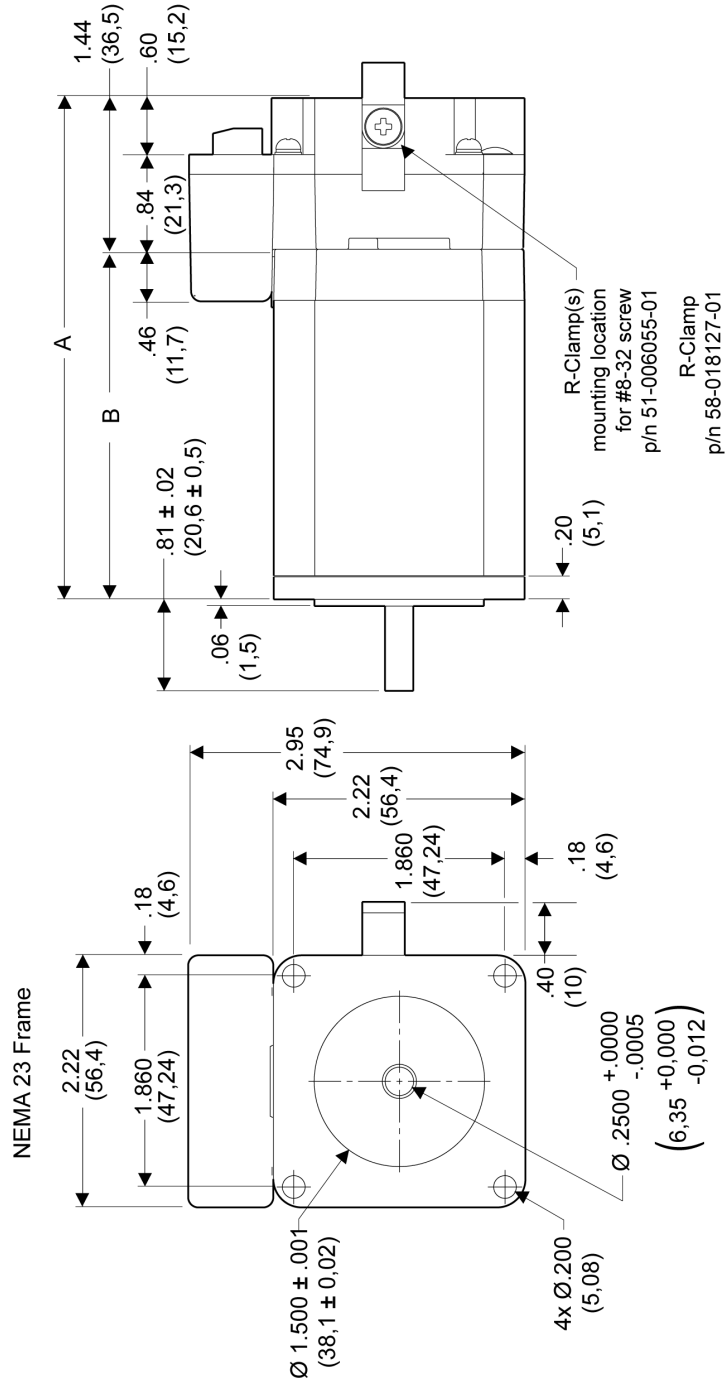

Figure 27 Drive/Motor Dimensions

Drive/Motor Specifications

Table 3 provides parameters, bearings information, and certifications for the Integral E Integrated Drive/Motor.

Parameters	Units	IE231	IE232	IE233
Static Torque	oz-in (Nm)	67.1 0.473726	148.5 1.04841	244.2 1.724052
Rotor Inertia	oz-in ² (kg-cm ²)	0.7 0.1281	1.5 0.2745	2.6 0.4758
Drive Current	A pk A rms	2.80 1.98	2.80 1.98	2.80 1.98
Detent Torque	oz-in (N-m)	2.63 0.019	5.90 0.042	8.38 0.059
Bearings				
Thrust Load	lb (kg)	13.00 5.91	13.00 5.91	13.00 5.91
Radial Load (0.79 inches from face)	lb (kg)	15.00 6.82	15.00 6.82	15.00 6.82
Shaft End Play	in at 2.2 lbs (mm)	0.003 0.0762	0.003 0.0762	0.003 0.0762
Shaft Radial Play in at 1 lb	in (mm)	0.001 0.0254	0.001 0.0254	0.001 0.0254
Motor weight	lb (kg)	1.3 [.59]	1.8 [.82]	2.6 [1.18]
Certifications		UL recognized CE (EMC)	UL recognized CE (EMC)	UL recognized CE (EMC)

Table 21 Drive/Motor Parameters

Motor Performance

	Performance Specifications
Accuracy	±10.0 arcminutes typical (unloaded, bidirectional)
Repeatability	±5 arcseconds typical (unloaded, bidirectional)
Hysteresis	Less than 2 arcminutes—0.0334° (unloaded, bidirectional)

Table 22 Motor Performance Specifications

Speed/Torque Curves

IE231

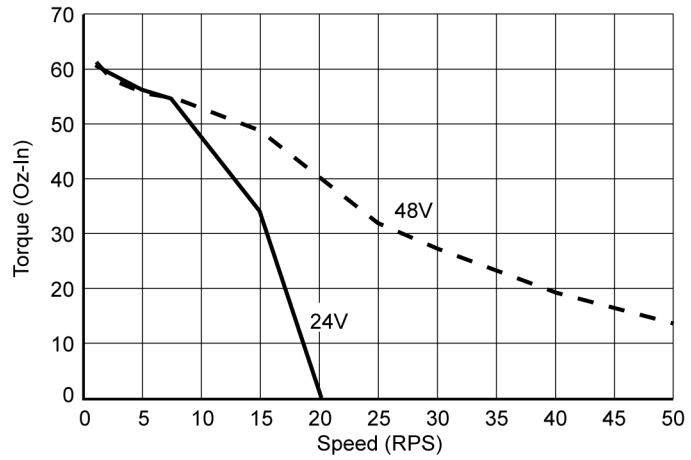

IE232

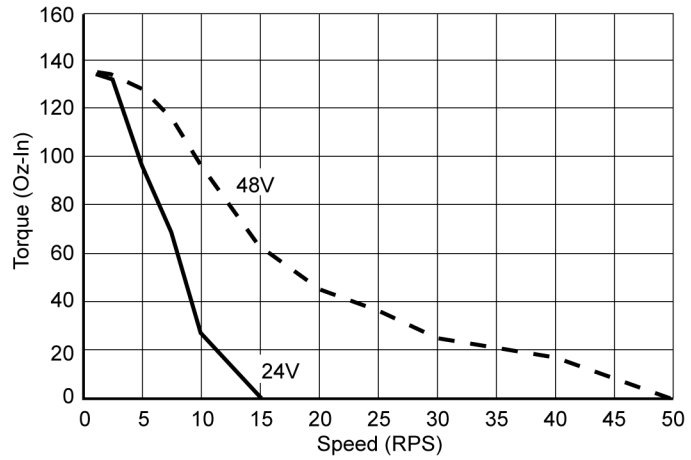

IE233

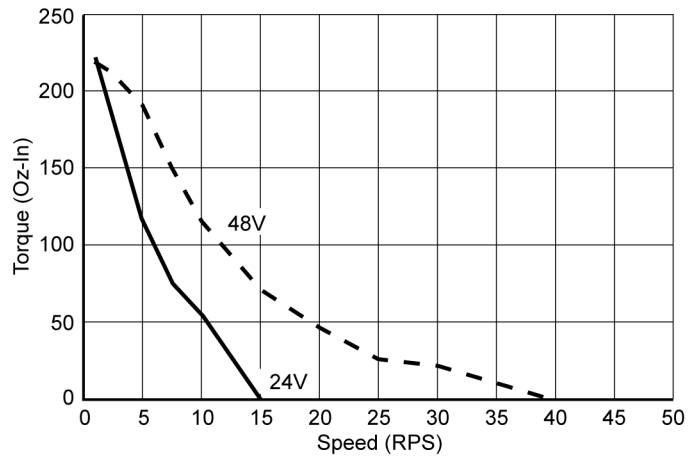



Figure 28 Speed Torque Curves

Electrical Specifications

The Integral E Integrated Drive/Motor provides connections for DC power through two positions of a ten-position removable screw terminal connector. (I/O connections occupy the remaining positions.) Figure 29 on page 64 shows the connector and positions. The unit operates from an external DC power supply, in the range of 24 VDC to 48 VDC (–10%, +5%).

For information on the device’s circuits and signal paths, see Figure 23 Integral E I/O Circuit Schematic on page 44.



Warning!



The Integral E operates in the range of 24 VDC to 48 VDC (–10%, +5%). Voltage above 50 Volts may damage the unit.

The drive/motor has internal protection for a limited regenerative load, but it does not provide over-voltage protection from a poorly regulated supply.

Peak Power Ratings

Table 23 contains peak power ratings for the Integral E to help you choose a power supply. Parker Hannifin recommends using the power supplies in Table 2 Integral E Drive/Motor Accessories on page 2.

Drive/Motor	Voltage (VDC)	Peak Power Speed (RPS)	Torque (Oz-In)	Power Input (Watts)	Motor Current (Amps)	Shaft Power (Watts)	Drive Losses (Watts)
IE231	24	10	48	38.8	1.65	21.29	17.51
IE231	48	19	42	64.6	1.36	35.40	29.20
IE232	24	3	128	38.7	1.65	17.03	21.67
IE232	48	8	112	68.3	1.44	39.75	28.55
IE233	24	2	210	44.6	1.9	18.63	25.97
IE233	48	7	158	76.3	1.6	49.06	27.24

Table 23 Peak Power Ratings

Conversions

Use the following formulas to convert values in watts to the desired units of measurement.

- To convert Watts to horsepower, divide by 746
- To convert Watts to BTU/hour, multiply by 3.413
- To convert Watts to BTU/minute, multiply by 0.0569

Power Supply Requirements

The Integral E operates from an external DC power supply in the range of 24 VDC to 48 VDC (-10%, +5%). The unit draws the minimum current shown in Table 24 when the motor is not delivering shaft power. (For power consumption while driving a load, see Table 23 on page 62.)

Current Draw from DC Power Supply (No Shaft Power)			
Voltage	Enabled without Standby	Enabled with Standby	Shutdown
24	1.01 Amps	0.244 Amps	0.053 Amps
48	0.545 Amps	0.185 Amps	0.035 Amps

Table 24 Current Draw from DC Power Supply

Short Circuit Protection

The Integral E is protected against phase-to-phase and phase-to-ground short circuits. When the drive detects a short circuit in the motor or motor cabling, it stops producing motor current. This is a latched condition.

To restart the drive, use the following steps:

1. Remove power from the drive/motor.
2. Verify that the operating temperature is below the overtemperature limit
3. Cycle power to the drive/motor.

If these steps do not correct the problem, you must return the drive/motor for service.

Note: The Integral E Integrated Drive/Motor has no internal user-serviceable parts. If a problem develops with an internal motor wire, you must return the unit for service. For contact information, see "Technical Assistance" on the inside cover, page ii.

External I/O Connectors

I/O communication takes place through eight terminals of a ten-terminal screw terminal. Figure 12 illustrates the I/O connections on the Integral E. The I/O on the drive/motor is differential and optically isolated for noise immunity. It consists of the following signals:

- Step Input
- Direction Input
- Shutdown Input
- Fault Output

Each of the signals provide connections for both the + and – inputs to allow maximum flexibility.

Figure 29 shows the I/O connectors on the Integral E.

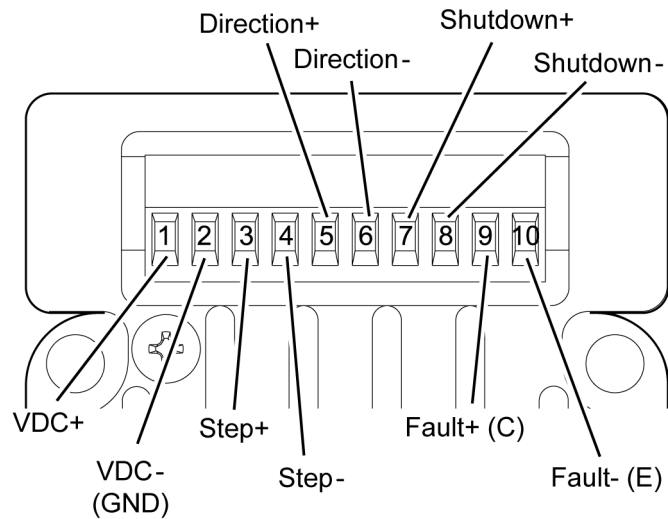

Figure 29 Controller Connections

Specifications for input and output connections follow in this section. For additional information, see Figure 23 Integral E I/O Circuit Schematic on page 44. Pinout tables for compatible Parker controllers appear on pages 25 through 27.



Warning!



Never connect or disconnect any component to or from the drive/motor with power applied. System damage or personal injury may occur.

Step Input

For every step pulse the drive receives on its step input, the drive commutates the motor to increment the rotor position. To send a step pulse to the drive, apply a positive voltage to **STEP+** with respect to **STEP-**. The drive registers the pulse on the rising edge.

The step input is an optically isolated, high-speed input capable of responding to pulse rates in excess of 1.5 MHz. Driving the step input differentially ensures accurate step counts and provides the best noise immunity.

Your output driver must be capable of providing a minimum of 6.5 mA drive current at approximately 3.5 VDC drive voltage. Table 25 contains the step input terminal specifications.

Step Input Specifications	
Input Current	6.5 mA minimum
	15 mA maximum
Input Voltage	3.5V minimum (min. required for on or high signal)
	5.35V maximum*
Step Pulse	200 nanosecond minimum pulse width
	200 nanosecond minimum off time
	1.5 MHz maximum pulse rate (40% to 60% duty cycle)
Optically Isolated	Yes
*You may use higher voltages if you add an external current-limiting resistor to ensure that the current does not exceed the maximum-input-current specification.	
Note: As a custom product, Parker Hannifin can modify the drive/motor for higher I/O input voltage.	

Table 25 Step Input Specifications

Direction Input

While a positive voltage is applied to **DIRECTION+** with respect to **DIRECTION-**, the drive commutates the motor in the clockwise (positive) direction as it receives step pulses on its step input.

While zero voltage (or a negative voltage) is applied to **DIRECTION+** with respect to **DIRECTION-**, the drive commutates the motor in the counterclockwise (negative) direction as it receives step pulses.

The input is optically isolated. You can drive the input differentially, or from a single-ended source.

Note: If the direction input is *not* activated (connected), the motor rotates counterclockwise.



Warning!



Reverse voltage in excess of 6 VDC may damage this device.

Your output driver must be capable of providing a minimum of 6.5 mA drive current at approximately 3.5 VDC drive voltage to ensure proper operation.

Direction input may change polarity concurrently with the first step pulse. However, we recommend that you stabilize the direction input for one microsecond before the drive receives the first pulse to allow for signal propagation delay.

Table 26 contains the direction input terminal specifications.

Direction Input Specifications	
Input Current	6.5 mA minimum
	15 mA maximum
Input Voltage	3.5V minimum (min. required for on or high signal)
	5.35V maximum*
Optically Isolated	Yes
*You may use higher voltages if you add an external current-limiting resistor to ensure that the current does not exceed the maximum-input-current specification.	
Note: As a custom product, Parker Hannifin can modify the drive/motor for higher I/O input voltage.	

Table 26 Direction Input Specifications

Shutdown Input

You can use the shutdown input to shutdown, or disable, the Integral E drive/motor. To activate shutdown, apply a positive voltage to **SHUTDOWN+** with respect to **SHUTDOWN-** when the motor is not moving. During shutdown, the drive turns off current to the motor. The current stays off as long as the voltage is maintained on the shutdown input.

When you remove the voltage on the input, shutdown ends. The drive restores current to the motor, in the same phase relationship that existed before shutdown was invoked.

The shutdown input may also be driven differentially.

Table 27 contains the shutdown input terminal specifications.

Shutdown Input Specifications	
Input Current	2.5 mA minimum
	30 mA maximum
Input Voltage	3.5V minimum (min. required for on or high signal)
	13V maximum
	5V maximum reverse voltage
Active Level	While voltage is applied, current to motor is shut down. When voltage is removed, normal operations resume.
Time	250 nanosecond minimum width
Optically Isolated	Yes

Table 27 Shutdown Input Specifications

Fault Output

The fault output is an open-collector (C), open-emitter (E) output from an OPTO isolator. **FAULT+** is the open-collector output and **FAULT-** is the open-emitter output. The output transistor conducts when the drive is functioning properly. The transistor does not conduct when any of the following conditions exist:

- No power is applied to the drive.
- There is insufficient voltage (<22 VDC).
- The drive detects a motor fault.
- The shutdown input is enabled.

The fault output has the following electrical characteristics:

- $BV_{CEO} = 30V$
- $V_{CE\ sat} = 1.0V$ maximum
- Collector current = 30 mA maximum
- Maximum power dissipation = 75 mW per transistor (2 per SOIC-8 package)

DIP Switches

Figure 30 shows the location and settings for the four-position DIP switch on the back of the drive/motor.

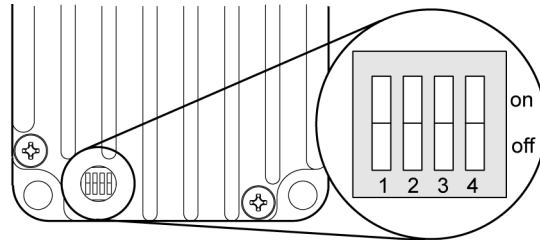

	1	2	3	4
Automatic Standby				
Enabled	on			
Disabled	off			
Drive Resolution				
3,600		on	on	
36,000		on	off	
2,500		off	on	
25,000		off	off	
Automatic Test*				
Enabled				on
Disabled				off

*1 rps for 2 revolutions in each direction until shutdown or power removed

Figure 30 DIP Switch Locations and Settings



Warning!



Remove power before setting DIP switches. Possible damage or injury may occur.

Default Settings

The factory default position for all switches is **off** (down). For the drive/motor to operate correctly, you may need to set the DIP switches for your application.

Automatic Standby

Set DIP switch 1 to the **off** (down) position if you do not use automatic standby. Set this switch to the **on** (up) position to use automatic standby. The automatic standby function allows the motor to cool when it is not moving. Automatic standby reduces motor current by 50% if the drive does not receive a step pulse for one second. Full current is restored upon the first step pulse that the drive receives. Be aware that reduced current results in reduced holding torque.

Drive Resolution

Set DIP switches 2 and 3 for drive resolution. There are four settings, measured in steps per revolution: 36,000, 25,000, 3,600, and 2,500. The default setting is 25,000 steps per revolution (switches 2 and 3 **off** or down). See Figure 30 on page 68 for drive resolution settings.

Be sure to set your controller to the same resolution as your integrated drive/motor. If the controller resolution and the drive resolution do not match, the system does not properly scale commanded accelerations and velocities.

Automatic Test

DIP switch 4 enables or disables the automatic test function, which verifies that the drive/motor works properly. Set this switch to the **on** (up) position to enable the automatic test function. For more information, see the section, "Automatic Test," on page 10.

Index

- 6K controller, pinout..... 25
- accessories 2
- ACR9000/RBC 1505 breakout box, pinout
..... 27
- airborne contaminants.....31, 58
- ambient temperature 30, 56, 57
- anti-resonance..... 6
- automatic standby 19, 68
- automatic test..... 12, 19, 69
 - procedure for motor..... 10–12
- bearings15, 60
- breakout boxes, pinouts25–27
- cables
 - RF bonding..... 48
 - routing48, 50
 - shielding 50
- CE, EMCviii, 15, 46–54, 60
- certifications 15, 60
- circuits
 - I/O schematic..... 44
 - overtemperature..... 31, 39, 57
 - protective.....6, 39
 - short circuit protection39, 63
- clamshell clamp 48, 51, 53
- clockwise motion..... 14
- connections
 - controller..... 12, 19, 23, 24, 64–67
 - DC power11, 13, 33–36
 - I/O 19, 23, 24, 64–67
 - load31–33
 - system4, 5, 53
 - system overview 4, 5
- connectors
 - breakout box pinouts25–27
 - controller pinouts.....25–27
 - DC power9, 11, 13, 33–36
 - I/O 9, 19, 20, 23, 24, 64–67
- controllers
 - compatible models 3, 25–27
 - connecting 12, 19, 23, 24, 64–67
 - test setup procedure 12–14
- conversion formulas
 - Watts to BTU/hour.....35, 62
 - Watts to BTU/minute35, 62
 - Watts to horsepower35, 62
- cooling 28, 31, 56
- counterclockwise motion 14
- coupling32, 33
 - manufacturers 33
- cradle configuration 28
- current, drive/motor..... 15, 36, 60, 63
- DC power *See* power, DC
- detent torque15, 60
- dimensions 29
 - drive/motor17, 59
 - NEMA 23 frame 17
 - panel layout 57
- DIP switches
 - automatic standby 19, 68
 - automatic test 19, 69
 - default settings.....18, 68
 - drive resolution.....19, 69
 - overview..... 6
 - settings 10, 12, 18, 68
- direction input.....6, 21, 66
- documentation 3
- drive resolution 19, 69
- earth-grounded enclosure..... 48
- electrical
 - specifications 62, 63
- electrical noise 8, 19, 40, 64
- electrostatic discharge 8
- EMCviii, 15, 46–54, 48, 60
 - filter49
 - installation hardware..... 51
 - installation requirements47–53
- environmental specifications 30, 31, 56–58
 - cooling 56
 - heatsink 56
 - humidity 57
 - mounting clearance..... 57
 - overtemperature shutdown fault 57
 - temperature 56
 - temperature, ambient..... 56, 57
- European Conformance Statementviii
- fault
 - output6, 22, 67
 - overtemperature shutdown...30, 31, 39, 56, 57
- ferrite absorbers 51
- filters
 - EMC 49
 - mains 49, 50
- foot-mount 28
- heatsink.....28, 31, 56
- humidity 30, 31, 56, 57
- I/O
 - connections 19, 23, 64–67
 - connectors..... 9, 20
 - direction input6, 21, 66
 - fault output6, 22, 67
 - overview..... 6
 - schematic 44
 - shutdown input.....6, 22, 67
 - step input.....6, 20, 65
- inputs..... *See also* I/O
 - direction6, 21, 66
 - shutdown6, 22, 67
 - step6, 20, 65
- installation18–37
 - EMC hardware 51
 - EMC requirements.....47–53
 - LVD..... 53
 - overview..... 9
 - panel mounting..... 49, 53
 - precautions..... 8
 - recommended process 9
 - testing..... 36
- liquids, precautions with 31, 57
- load
 - connecting.....31–33
 - misalignment 32
 - radial..... 15, 60
 - thrust..... 15, 60

LVD requirements	47
mechanical specifications.....	59–63
misalignment, load.....	32
models	3, 17, 29
weight.....	30, 56
modifications, drive/motor	28
motion	
clockwise.....	14
counterclockwise	14
motor performance	37, 60
mounting.....	28–31
clearance	30, 57
EMC requirements	47
overview	6
panel	49, 53
precautions	28
NEMA 23 frame.....	17
optical isolation	19, 64
outputs, fault.....	6, 22, 67. <i>See also</i> I/O
overtemperature	
shutdown fault	30, 31, 39, 56, 57
panel layout requirements	57
parameters.....	<i>See</i> specifications
peak power ratings	35, 62
performance	
EMC.....	49
specifications.....	15, 37, 60
pinouts	
6K controller.....	25
ACR9000/RBC 1505 breakout box.....	27
RBC breakout box	26
power, DC	
applying	11, 14, 34
connecting	11, 13, 33–36
connectors	9, 33, 62
peak power ratings	35, 62
range	4, 36, 62, 63
supply requirements	34, 36, 63
protection	
overtemperature.....	31, 39
protective circuits	6, 39
short circuit	39, 63
radial load	15, 60
RBC breakout box, pinout.....	26
R-Clamp	2, 17, 48, 51–53, 59
regulatory agencies.....	54
RF bonded terminations	50
rotor inertia	15, 60
safety.....	ix, x, 46
schematic, I/O circuits.....	44
screw terminal	2, 4, 6, 9, 12, 20
shaft	
end play.....	15, 60
misalignment.....	32
radial play	15, 60
ship kit	2
short circuit protection.....	39, 63
shutdown	
input	6, 22, 67
overtemperature fault	30, 56, 57
specifications	
bearings	15, 60
drive/motor	15, 60
electrical.....	62, 63
environmental.....	30, 31, 56–58
mechanical	59–63
performance	15, 37, 60
speed torque	16, 61
speed torque curves.....	16, 61
standards	viii, 54
static torque	15, 60
step input	6, 20, 65
storage temperature.....	30, 56
support, technical.....	ii, 3, 42
symbols	ix
system	
block diagram	5
connections	4, 5, 53
overview.....	4, 5
technical support.....	ii, 3, 42
temperature.....	56
ambient.....	30, 56, 57
overtemperature shutdown fault	30, 31, 39, 56, 57
storage.....	30, 56
terminals <i>See also</i> connectors and screw	
terminal	33, 62
DC power	33, 62
testing	
automatic, for motor	10–12
controller setup.....	12–14
installation.....	36
troubleshooting.....	40
thrust load	15, 60
torque	
detent	15, 60
static.....	15, 60
troubleshooting.....	41
troubleshooting	
basics.....	39
common problems & solutions	41
electrical noise	48
load misalignment.....	32
maintenance.....	40
UL certification	15, 60
varistors	51
weight, drive/motor.....	30, 56