

DIRECT DRIVE LINEAR SERVO ACTUATOR
LM Series

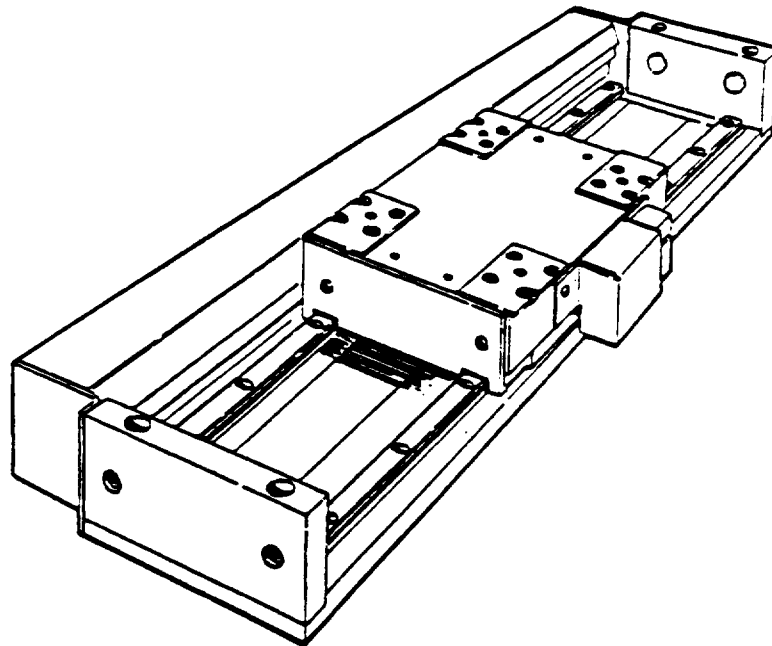

Parker Hannifin Corporation
CompuMotor Division
5500 Business Park Drive
Rohnert Park, CA 94928
Phone: (800) 358-9068
(707) 584-7358
FAX: (707) 584-8029
E-mail: info@cmotor.com

p/n 88-016176-01 Rev A
June 1, 1996

IMPORTANT

User Information

To ensure that the equipment described in this user guide, as well as all the equipment connected to and used with it, operates satisfactorily and safely, all applicable local and national codes that apply to installing and operating the equipment must be followed. Since codes can vary geographically and can change with time, it is the user's responsibility to identify and comply with the applicable standards and codes. **WARNING: Failure to comply with applicable codes and standards can result in damage to equipment and/or serious injury to personnel.**

Personnel who are to install and operate the equipment should study this user guide and all referenced documentation prior to installation and/or operation of the equipment.

In no event will the provider of the equipment be liable for any incidental, consequential, or special damages of any kind or nature whatsoever, including but not limited to lost profits arising from or in any way connected with the use of this user guide or the equipment.

© Compumotor Division of Parker Hannifin Corporation, 1997
— All Rights Reserved —

The information in this user guide, including any apparatus, methods, techniques, and concepts described herein, are the proprietary property of Parker Compumotor or its licensors, and may not be copied, disclosed, or used for any purpose not expressly authorized by the owner thereof.

Since Parker Compumotor constantly strives to improve all of its products, we reserve the right to change this user guide and equipment mentioned therein at any time without notice.

Technical Assistance ⇨ *Contact your local automation technology center (ATC) or distributor, or ...*

North America and Asia:

Compumotor Division of Parker Hannifin
5500 Business Park Drive
Rohnert Park, CA 94928
Telephone: (800) 358-9070
Fax: (707) 584-3793
FaxBack: (800) 936-6939
BBS: (707) 584-4059
e-mail: tech_help@cmotor.com

Europe (non-German speaking):

Parker Digiplan
21 Balena Close
Poole, Dorset
England BH17 7DX
Telephone: 0202-690911
Fax: 0202-600820

Germany, Austria, Switzerland:

HAUSER Elektronik GmbH
Postfach: 77607-1720
Robert-Bosch-Str. 22 • D-77656 Offenburg
Telephone: (0781) 509-0
Fax: (0781) 509-176



Compumotor

INTRODUCTION

Thank you very much for purchasing our LINEARSERV DD Servo-Actuator. The LINEARSERV is a high-speed, highly accurate linear servo-actuator which can be used in a wide range of field applications related to factory automation, including semiconductor-manufacturing equipment, automatic assembly equipment, high accuracy positioning equipment, etc. This instruction manual covers the model that combines the LM series DD Servo-Actuator. Be sure to read this instruction manual prior to operating the LINEARSERV.

NOTICE

- The copying or reproduction by any means of all or any part of the contents of this manual without permission is strictly prohibited.
- Parker Hannifin Compumotor Div reserves the right to change the contents of this manual without prior notification.
- While every effort has been made to ensure accuracy in the preparation of this manual, if you should, however, notice any discrepancies, errors or omissions, kindly contact your dealer or the authorized service personnel of Corporation or its authorized agency.
- Parker Hannifin Compumotor Div shall bear no responsibility for indirect or consequential damages such as, but not so as to limit the foregoing, the loss of profit, or the loss of production, caused by the use of our products in accordance with this manual.

Warning on Installation and Operation

1. The head amplifier is adjusted separately in conjunction with the coupled motor. Therefore, do not change the motor and head amplifier combination. (Make sure that the serial number of the motor and the head amplifier is the same.)
2. Never install the motor with the slider fixed and the base set free for movement.
3. Ensure that the power is switched off when removing the side panel of the driver for jumper setting, etc. Dangerously high voltage is present inside the unit.
4. Ensure adequate grounding at the ground terminal.
5. Since the clearance between the slider and the base is extremely small (0.1 mm), make sure that there are no contaminants, refuse, or fouling on the base.

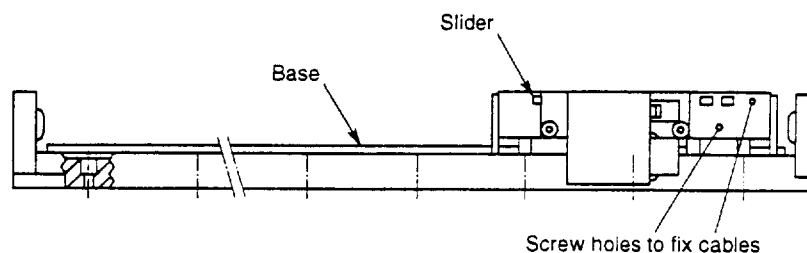

6. To prevent cable breakage, always fix cables coming out of the slider section to the side of the slider.
7. Use a screw which will not exceed the effective screw depth of the slider section in order to fix the load. The use of too long screws may cause damage to the slider.
8. Because the surface of the motor is magnetic, materials easily affected by magnetism must be kept away from or must not be close to the motor.
9. Install the motor in an appropriate location as the motor is not dust-proof, watertight or oil-proof.
10. Because glass materials are incorporated in the motor, avoid mechanical shock or vibration.
11. If you remove the clamps mounted on the top and bottom surfaces of the driver box, avoid using screws having a length of 6 mm or greater that fix the clamps to the driver when you mount the clamps on the driver again.
12. On the LINEARSERV LM/TM series, a rust-prevention coating has been applied to the motor base. Before assembling the motor, completely remove this coating using a cloth or paper dipped in a petroleum or chlorine solvent.
13. Never disassemble or modify the LINEARSERV. When such disassembly or modification is required, consult Yokogawa Precision Corporation or its authorized agency. Yokogawa Precision Corporation, or its authorized agency, accepts no responsibility for a disassembled or modified LINEARSERV without permission.

CONTENTS

INTRODUCTION	i
Warning on Installation and Operation.....	ii
1. PRODUCT OUTLINE	
1.1 LINEARSERV, LM Series	1-1
1.2 Standard Product Configuration.....	1-2
1.3 Model and Suffix Codes	1-3
2. FUNCTIONAL DESCRIPTION	
2.1 Motor	2-1
2.2 Driver.....	2-1
2.3 Driver (Front Panel)	2-2
3. PREPARATION FOR OPERATION	
3.1 Initial Setting	3-1
(1) Setting of the Jumper Switches in the Driver Box	3-1
(2) Jumper Settings Done Prior to Shipment	3-1
3.2 Control Mode Setting	3-3
(1) Control Mode Types	3-3
(2) Functions and Details on Jumpers and Switches	3-4
3.3 Connection	3-6
(1) External Connection Outline Diagram	3-6
(2) Cable Sizes and Rated Currents	3-6
(3) Wiring Cautions	3-6
(4) Optional Cables	3-7
(5) Connection Between the Motor and the Driver	3-7
(6) Pin Arrangement of Connection Terminals and Connection Signals	3-8
(7) Example of Connection	3-10
(8) Connection to External Controller	3-11
3.4 I/O Signals	3-12
(1) Input	3-12
(2) Output	3-13
3.5 Installation	3-14
(1) Motor Mounting	3-14
a) Installation Location	3-14
b) Mechanical Coupling	3-14
(2) Driver Mounting	3-15
a) Installation Location	3-15
b) Mounting Procedure	3-15
(3) Fixing Cables to the Slider	3-15
3.6 Service Life	3-17
3.7 Definitions and Measurement Methods of Specification Accuracies	3-19

4. CAUTION ON OPERATION

4.1	Cautions on I/O Signals	4-1
(1)	Position Command Pulse Input Signal	4-1
(2)	Motor Rotating Direction Command Input Signal	4-1
(3)	Velocity Command Input	4-1
(4)	Current Command Input	4-1
(5)	Current Limit Input	4-1
(6)	Velocity Monitoring Output	4-2
(7)	A/B Phase, UP/DOWN Pulse Output Signals	4-2
(8)	Origin Pulse Output Signal	4-3
(9)	ERR Output Signal	4-4
4.2	Power On/Off	4-4

5. CONTROL MODE AND ADJUSTMENT

5.1	Position Control Mode Adjustment	5-1
(1)	I-PD Position Control	5-1
(2)	P Position Control	5-2
(3)	Position Control System Adjustment Procedure	5-2
(4)	Procedure for Adjustment Without Measuring Instruments	5-4
5.2	Velocity Control Mode Adjustment	5-5
(1)	PI Velocity Control	5-5
(2)	P Velocity Control	5-5
(3)	Adjustment of Velocity Control System	5-5
5.3	Thrust Control Mode Adjustment	5-6
5.4	Mechanical Resonance Notch Filter Adjustment	5-7

6. MAINTENANCE AND INSPECTION

6.1	Motor	6-1
6.2	Servo Driver	6-1

7. TROUBLESHOOTING AND MEASURES

7.1	Motor Problems and Measures	7-1
7.2	LED Displays	7-3

8. REFERENCE

8.1	Standard Specification	8-1
(1)	Motor	8-1
(2)	Driver	8-1
(3)	Environmental Specifications	8-1
8.2	Velocity vs Thrust Characteristics	8-3
8.3	External Dimensions	8-4
(1)	Motor	8-4
(2)	Driver	8-6
(3)	Head amplifier	8-6
8.4	Driver Block Diagram	8-7

1. PRODUCT OUTLINE

1.1 LINEARSERV, LM Series

The LINEARSERV, LM Series is a linear positioning actuator which adopts a direct drive method. The features of the actuator are that it has our unique interpolated optical linear encoder using a glass scale; fully closed high-precision positioning control; and a smooth driving characteristic.

Absolute accuracy: 10 μm or less/700 mm

Positioning repeatability: 0.1 to 0.5 μm

Small vibration: Fluctuation is 1% of the velocity.

Ratio of thrust to weight: 7G

The above four items prove the high-precision positioning characteristics that the LM series has. A mechanically field-proven linear guide is incorporated in the LINEARSERV LM series, ensuring highly stiff linear guidance to each load. The driver section has an I-PD positioning control function, enables high-precision positioning easily like handling a pulse motor, using a serial pulse command interface, and does not require complicated adjustment work. The volume of the actuator is three times smaller than our conventional actuators, realizing easy and simple use.

1.2 Standard Product Configuration

The standard product set consists of the following components. When unpacked, make sure that the product is the correct model, and that the types and quantities of standard accessories are also correct.

Part		Q'ty		
Main unit	Motor	1		
	Driver	1		
	Head amplifier	1		
Standard accessories	Motor	Connector (for CN5 terminal)	1	AMP (housing) for 4-pin connector/#172167-1 or 172338-1 AMP (housing) for 12-pin connector/#172170-1 or 172341-1 20 AMP (socket) 170365-3 connectors, 10 AMP 170366-3 connectors
		Connector (for CN6 terminal)	1	
	Driver	Connector (for CN1 terminal)	1	Manufactured by Fujitsu Connector: FCN241J050-G/E Cover: FCN230C050-D/E
		Connector (for CN2 terminal)	1	Manufactured by Fujitsu Connector: FCN241J020-G/E Cover: FCN230C020-C/E
	Head amplifier	Connector (for CN3 terminal)	1	Manufactured by Fujitsu Connector: FCN241J020-G/E Cover: FCN230C020-C/E
		Connector (for CN4 terminal)	1	Manufactured by JAE Connector: DA-15PF-N Cover: DA-C8-J10-F4-1

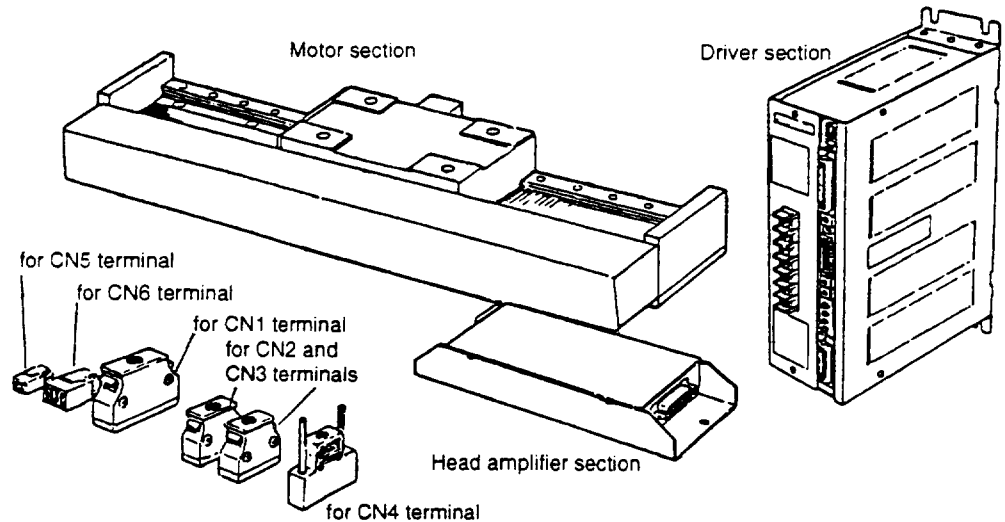

1.3

Compumotor's Linearserv P/N Format

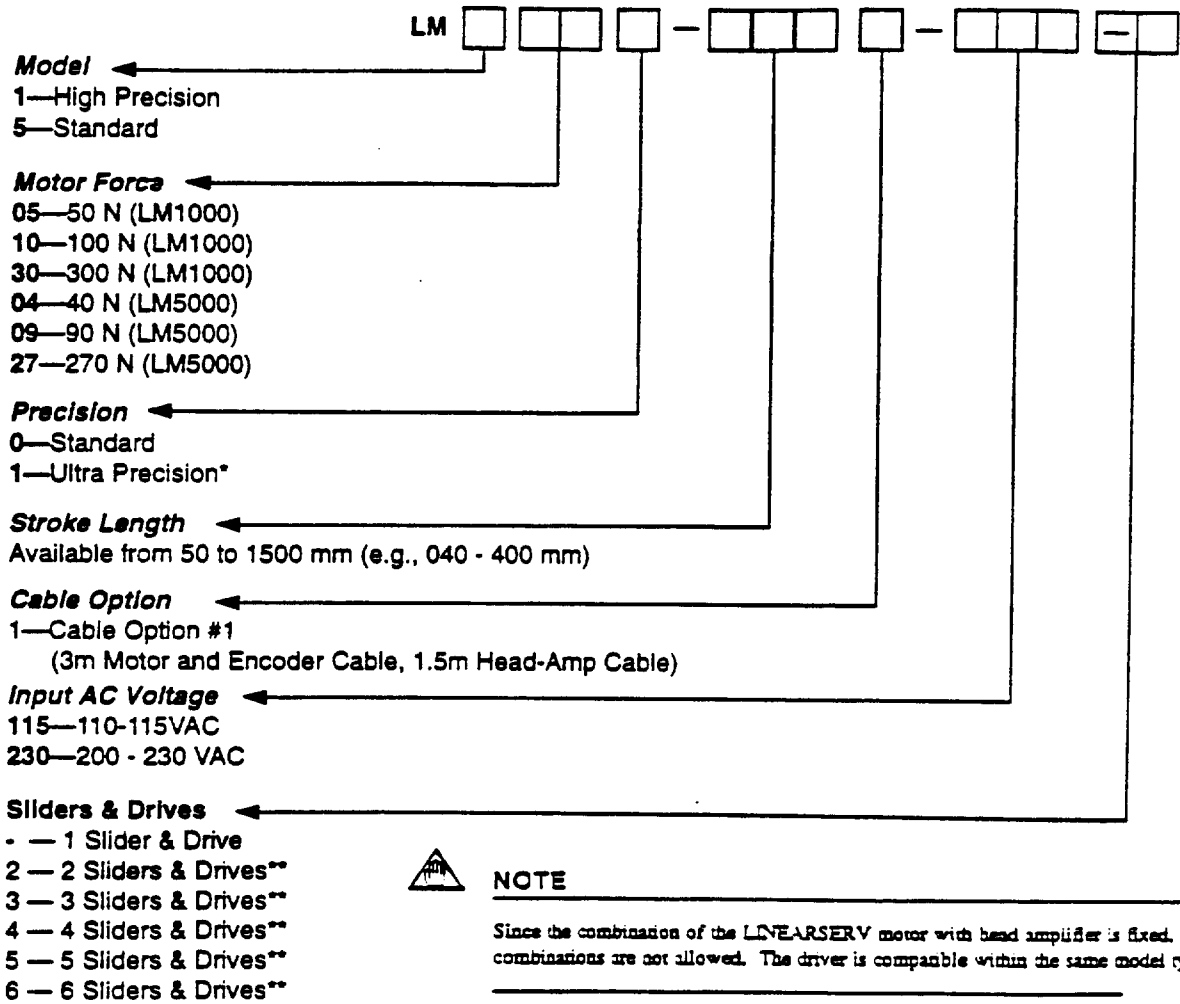

* This option is only available in the LM1000 Series and may be ordered through Compumotor's Custom Products Group.

** These options may be ordered through Compumotor's Custom Products Group.

YPC P/N Format (Reference)

(1) Motor section

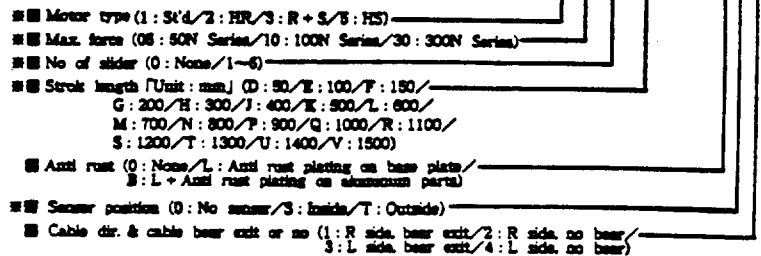

(2) Driver section

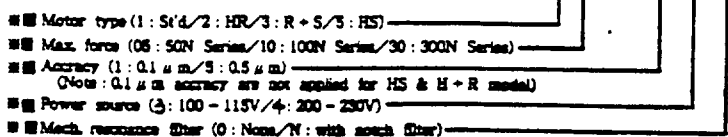

2. FUNCTIONAL DESCRIPTION

2.1 Motor

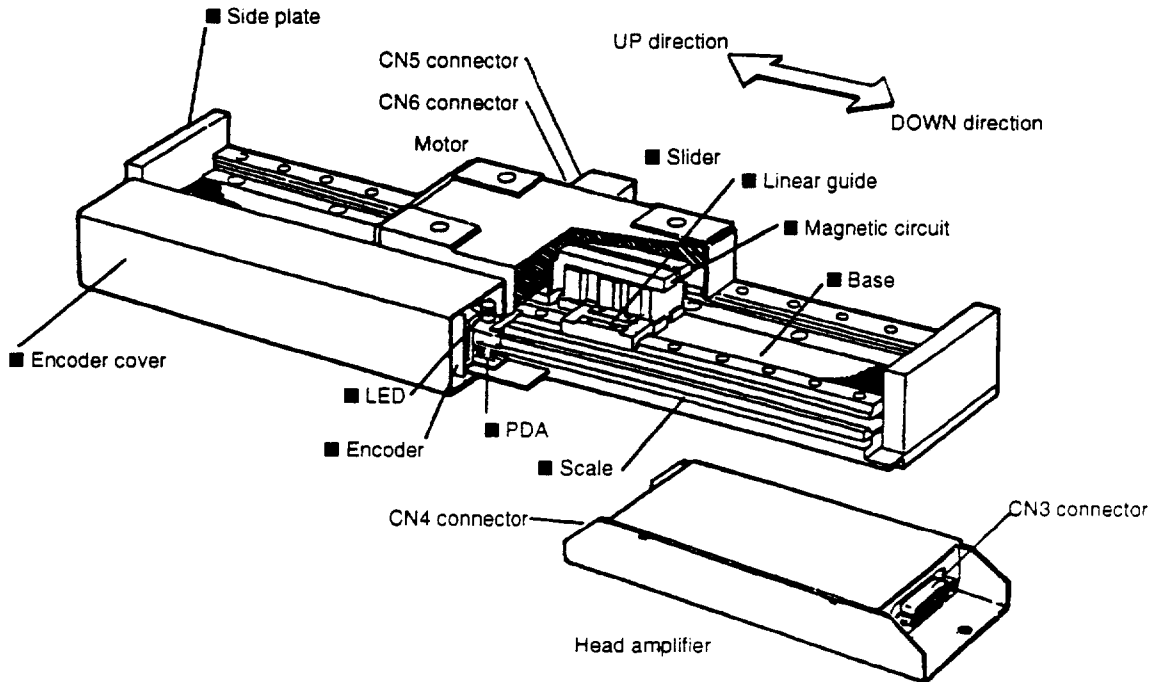

2.2 Driver

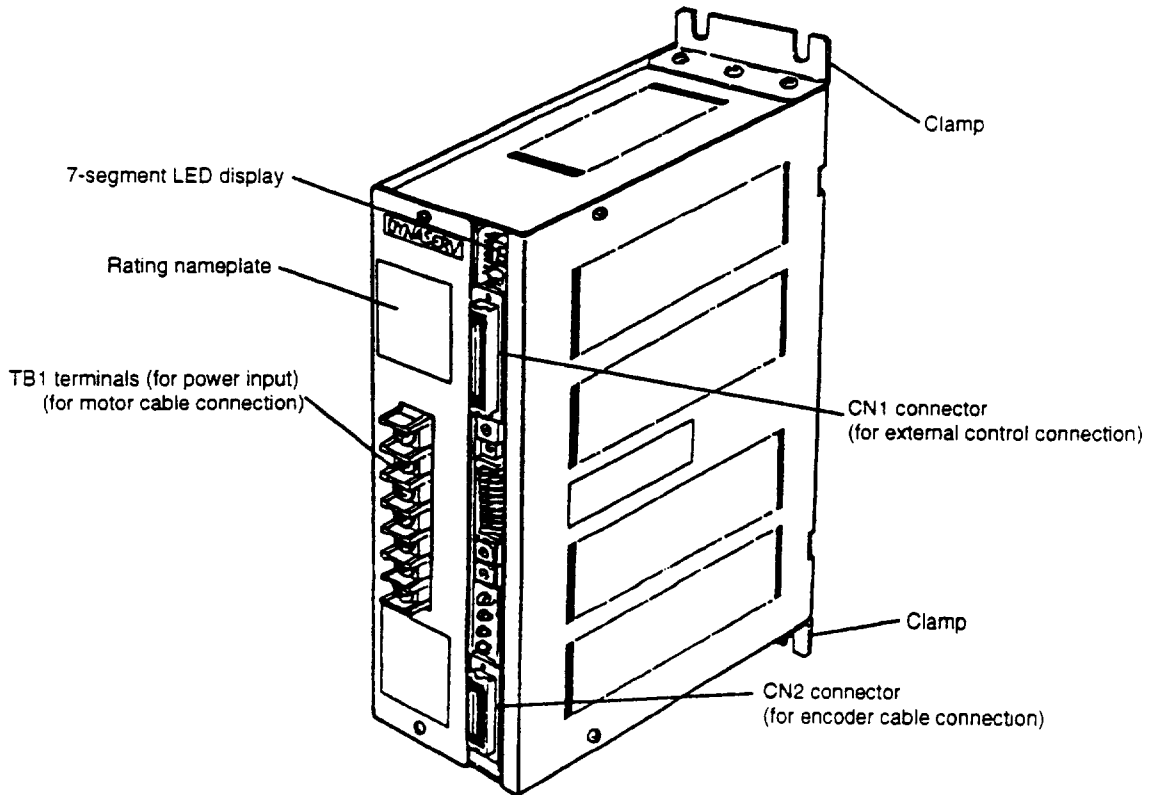

2.3 Driver (Front Panel)

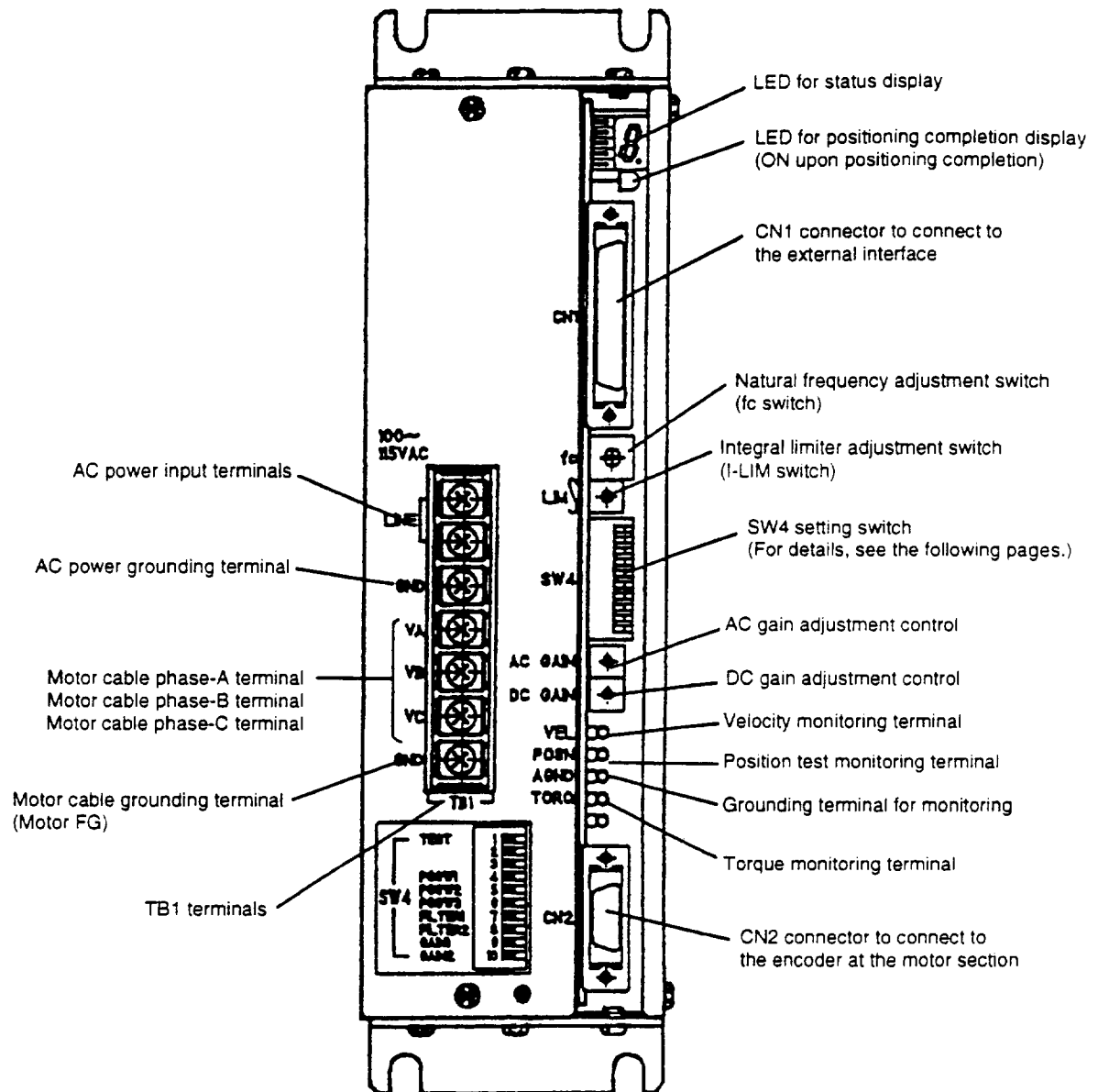

3. PREPARATION FOR OPERATION

3.1 Initial Setting

(1) Setting of the Jumper Switches in the Driver Box

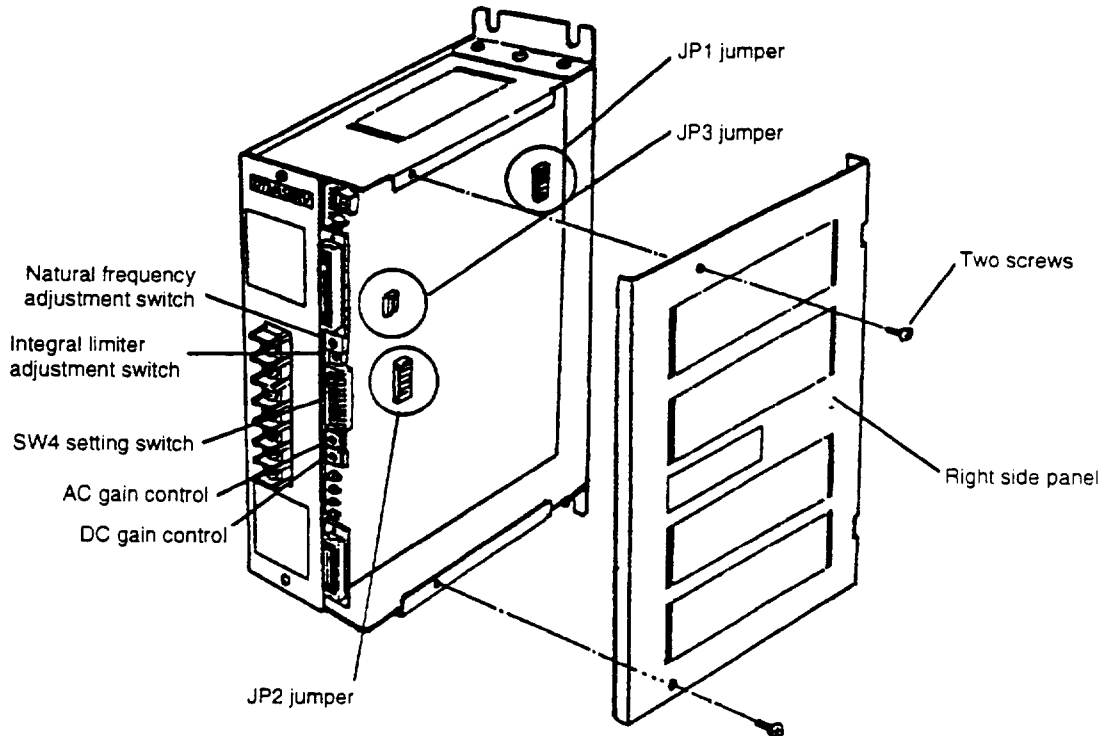

Some jumpers, switches, and controls within the driver box may need to be set by the customer. However, prior to shipment, they are set as shown below. See the figure above for their locations. To remove the side plate from the driver box, remove the two screws shown in the figure above.



WARNING

In order to commence this operation, the power must be turned off because of danger. Further, never touch a section generating high-voltages, even with the power turned off.

For the setting and adjustment procedures, see the following pages. Never touch the switches and variable resistors other than those specified.

(2) Jumper Settings Done Prior to Shipment

The statuses for jumpers, switches, and variable resistors in DYNASERV upon shipment are set as follows as standard. The tuning mode is set to the I-PD position control mode upon shipment.

JP1 jumper

Name	Setting status
MODE	■-■
CALIB	<input type="checkbox"/> <input type="checkbox"/>
RATE #1	■-■
RATE #2	■-■
UD/AB	■-■

■-■ : Shorted

: Open

JP2 jumper

Name	Setting status
I	<input type="checkbox"/> <input type="checkbox"/>
P	■-■
100	<input type="checkbox"/> <input type="checkbox"/>
200	<input type="checkbox"/> <input type="checkbox"/>
PV	■-■

■-■ : Shorted

: Open

JP3 jumper

Name	Setting status
VEL	<input type="checkbox"/> <input type="checkbox"/>
TORQ	<input type="checkbox"/> <input type="checkbox"/>

: Open

SW4 switch

Name	Setting status
DC GAIN	Minimum position
AC GAIN	Minimum position
fc	Set to "0"
I-LIM	Set to "0"

Variable resistors, switches

NO.	Name	Setting status
1	TEST	OFF
2	———	OFF
3	———	OFF
4	POSW 1	OFF
5	POSW 2	OFF
6	POSW 3	OFF
7	FILTER 1	OFF
8	FILTER 2	ON
9	GAIN 1	OFF
10	GAIN 2	OFF

3.2 Control Mode Setting

(1) Control Mode Types

The following six control modes are available for the DYNASERV DM Series (However, only the position control mode can be used in the <0.1- μ m version>):

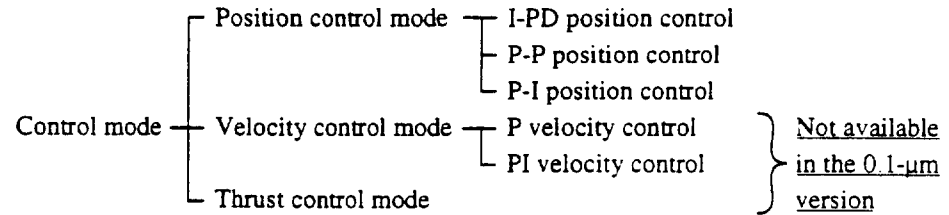

The following table shows the validity or nonvalidity of the switches and variable resistors related to the control mode and the jumper settings for each control mode.

List of Control Modes and Jumper Pin Switch Settings

Section	Jumper name Switch name	Position control mode			Velocity control mode		Thrust control mode	
		I-PD	P-P	P-I	P	PI		
Control board	JP1	MODE	■-■	■-■	■-■	□ □	□ □	□ □
		CALIB	□ □	□ □	□ □	□ □	□ □	■-■
		RATE #1 *	○	○	○	○	○	○
		RATE #2 *	○	○	○	○	○	○
		UD/AB	○	○	○	○	○	○
	JP2	I	□ □	□ □	■-■	□ □	■-■	□ □
		P	■-■	■-■	□ □	■-■	□ □	□ □
		100	○	○	○	○	○	○
		200	○	○	○	○	○	○
		PV	■-■	■-■	■-■	■-■	■-■	□ □
JP3	VEL	□ □	□ □	□ □	■-■	■-■	□ □	
	TORQ	□ □	□ □	□ □	□ □	□ □	■-■	
Front panel	SW4	TEST	○	○	○	○	○	×
		POSW 1-3	○	○	○	×	×	×
		FILTER 1,2	○	○	○	○	○	○
		GAIN 1,2	○	○	○	○	○	×
	fc	DC GAIN	○	○	○	○	○	×
		AC GAIN	×	×	○	×	○	×
		I-LIM	○	×	×	×	×	×

■-■: Jumper shorted

□ □: Jumper open

○: Valid. When the setpoint exerts influence on motor operation.

×: Invalid. When the setpoint does not exert influence on motor operation.

*: Invalid in 0.1- μ m version

(2) Functions and Details on Jumpers and Switches

The servo driver receives a signal from the encoder built into the motor, then outputs an A/B phase or UP/DOWN pulse signal to a higher-level controller. Jumpers related to the feedback pulse signal are [RATE#1 to 2] and [UD/AB]. In addition, the position command pulse signal multiplying factor is determined by the setting of [RATE#1 to 2].

a) [RATE#1 to 2] jumpers (JP1)

The adjustment of these jumpers can change the position command pulse signal by 1 to 8 times (see the table below for the 0.5- μ m version). Note, however, that resolution also varies in accordance with the variation of the multiplying factor.

Jumper Settings		Multiplying Factor	Resolution [pulses/inch (pulses/mm)]		
RATE#1	RATE#2		LM1000	LM1000*	LM5000
■ — ■	■ — ■	1	50800(2000)	254000(10000)	25400(1000)
□ □	■ — ■	0.5	25400(1000)	- -	12700(500)
■ — ■	□ □	0.25	12700(500)	- -	6350(250)
□ □	□ □	0.125	6350(250)	- -	3125(125)

*LM1000 Series with Ultra Precision option

b) [UD/AB] jumpers (JP1)

The selection of these jumpers enables the selection of the A/B phase or the UP/DOWN phase. The shorted jumper results in the A/B phase, and the open jumper, the UP/DOWN phase.

c) [100] [200] jumpers (JP2)

These jumpers are used to select the velocity signal filter cut-off frequency. The cut-off frequency is set to 100 Hz with [100] shorted; likewise, it is set to 200 Hz with [200] shorted. These jumpers must be opened if either one of the [#7, 8/FILTER 1, 2] subswitches in the SW4 switch is set to on.

d) [FILTER 1, 2] subswitches (SW4 switch)

These subswitches are used to set the first-order delay filter to regulate mechanical resonance. Setting the two subswitches can select the filter frequencies as shown in the table below. Select one of the frequencies in accordance with the load status.

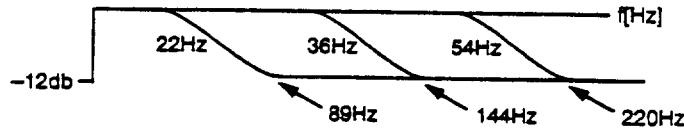

FILTER 1	FILTER 2	Frequency
OFF	OFF	No function
ON	OFF	54/220Hz
OFF	ON	36/144Hz
ON	ON	22/89Hz

e) [POSW 1 to 3] subswitches (SW4 switch)

When the position deviation reaches the positioning completion width (number of pulses) in the position control mode, the COIN signal becomes on and the positioning is completed. The number of pulses of the positioning completion width can be set or selected as shown in the table below by using the POSW 1 to 3 subswitches. Note that it may take so much time to complete positioning if the positioning completion width is small, resulting in insufficient adjustment.

POSW 1	POSW 2	POSW 3	Positioning completion width
OFF	OFF	OFF	1 pulse
ON	OFF	OFF	2 pulses
OFF	ON	OFF	4 pulses
ON	ON	OFF	8 pulses
OFF	OFF	ON	16 pulses
ON	OFF	ON	32 pulses
OFF	ON	ON	64 pulses
ON	ON	ON	128 pulses

f) [GAIN 1, 2] subswitches (SW4 switch)

These are subswitches to set the loop gain magnification when the loop gain is variably adjusted using the DC GAIN adjustment control provided at the front panel of the driver. Setting the two subswitches can select the multipliers as shown in the table below. The function to vary the gain multipliers by the GAIN 2 subswitch is the same as that of GAIN 2 signal of the CN1 connector. To use GAIN 2 signal, the GAIN 2 subswitch must be set to off. Refer to page 5-1 to do other settings for use with the GAIN 2 signal.

GAIN 1	GAIN 2	Gain multipliers
OFF	OFF	× 1
OFF	ON	× 6.6
ON	OFF	× 14
ON	ON	× 20

g) For f_c , I-LIM, DC GAIN, and AC GAIN, refer to Chapter 5, "CONTROL MODE AND ADJUSTMENT."

3.3 Connection

(1) External Connection Outline Diagram

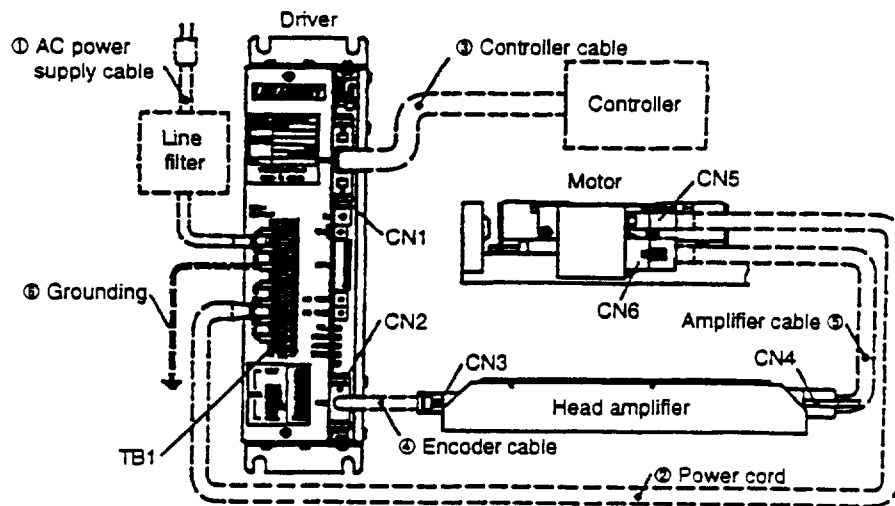

Note: The items indicated by the dotted lines must be provided by the customer (see the optional parts described below).

(2) Cable Sizes and Rated Currents

Cable		Specification	
Power Line	① AC Power Cable	Current (A)	5
		Cable Size	More than 0.5mm ² (20 AWG): Length: ≤ 30 m(98 ft)
	② Motor Cable	Current (A)	5
		Cable Size	More than 0.5mm ² (20 AWG): Length: ≤ 15 m(49 ft)
Signal Line	③ Controller Cable	Current (A)	100 mA DC Maximum
		Cable Size	0.2mm ² (24 AWG) twisted pair cable having an outer diameter of 14mm(0.55in) or less. Collectively shielded wire. Length: ≤ 3m(10 ft)
	④ Encoder Cable	Current (A)	100 mA DC Maximum
		Cable Size	0.2mm ² (24 AWG) twisted pair cable having an outer diameter of 14mm(0.55in) or less. Collectively shielded wire. Length: ≤ 10m(30ft)
	⑤ Head Amp Cable	Current (A)	100 mA DC Maximum
		Cable Size	0.3mm ² (22 AWG) twisted pair cable having an outer diameter of 9mm(0.35in) or less. Collectively shielded wire. Length: ≤ 5m(15 ft)
⑥ Grounding	Cable Size	More than 0.5mm ² (20 AWG)	

(3) Wiring Cautions

- Use the specified multi-core twisted pair cables with collective shielding for the controller, encoder, and head amplifier cables. Ensure proper end shield connections.
- Use thick conductors as grounding cables as much as possible. Ground the LINEARSERV through a resistance of less than 100Ω.
- Since high voltage and large current flow through the motor and the AC power cables, ensure proper wiring connections.
- Separate the power lines from the signal lines for wiring as much as possible. Avoid binding both lines together.
- Crimp tools are necessary for wiring of CN5 and CN6 terminals.

(4) Optional Cables

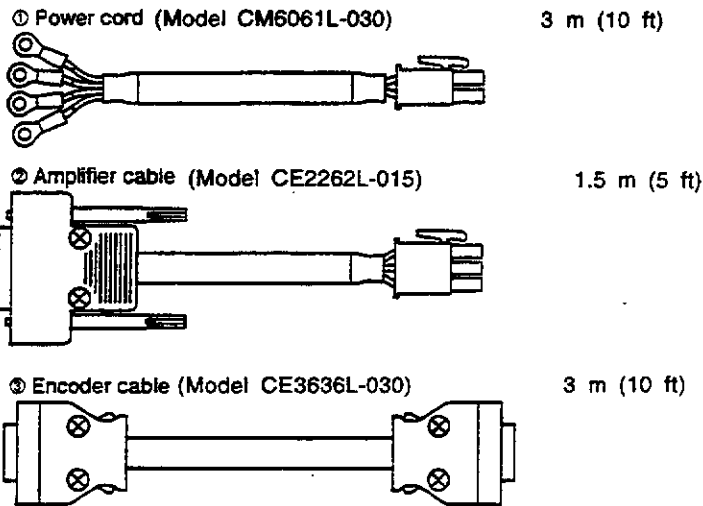

(5) Connection Between the Motor and the Driver



NOTE

Shielding must always be done for each line.

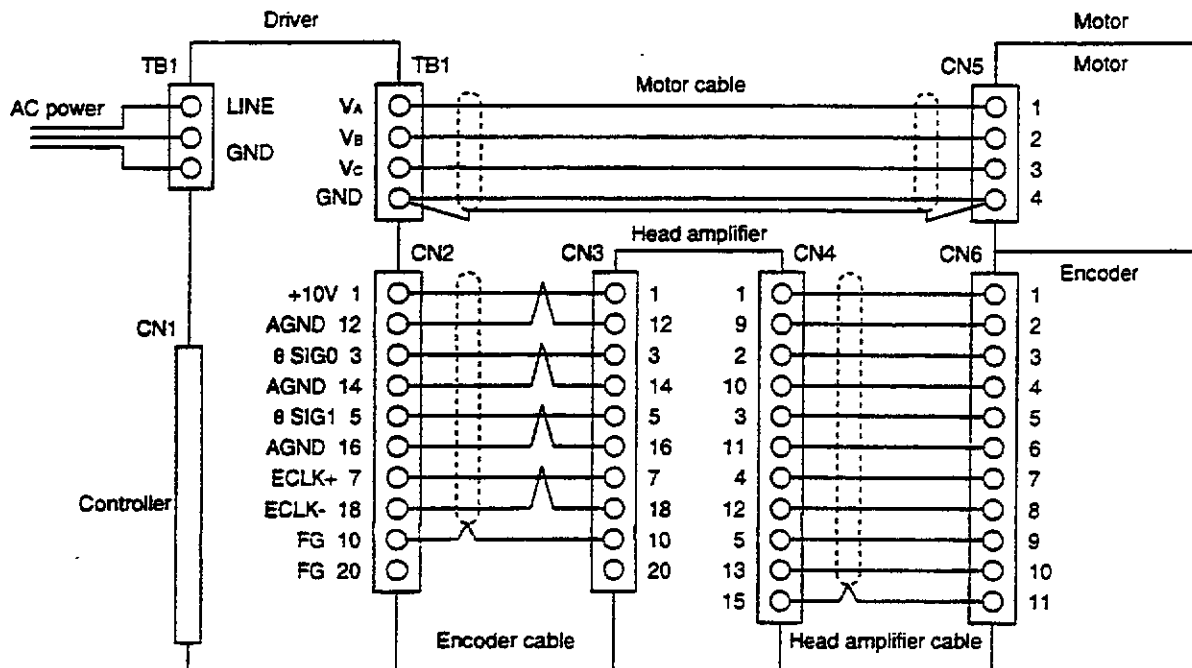

(6) Pin Arrangement of Connection Terminals and Connection Signals

a) CN1 terminal

Pin #	Signal name	Pin #	Signal name	Pin #	Signal name	Pin #	Signal name	Pin #	Signal name
1	COM+	11	ERR 0	21	Z+	31	RDY	41	A/U-
2	———	12	———	22	AGND	32	———	42	———
3	GAIN 2	13	SIGN+	23	TRQIN	33	ERR 3	43	B/D-
4	———	14	———	24	AGND	34	———	44	———
5	SRVON	15	PULS+	25	VELIN	35	ERR 1	45	Z-
6	———	16	———	26	COM-	36	———	46	———
7	COIN	17	A/U+	27	I/ACT/P/ACT	37	SIGN-	47	TLIM
8	———	18	———	28	IRST	38	———	48	GND
9	ERR 2	19	B/D+	29	RST	39	PULS-	49	VELMON
10	———	20	———	30	———	40	———	50	AGND

b) CN2 and CN3 terminals

Pin #	Signal name	Pin #	Signal name
1	+10V	11	———
2	———	12	GND
3	SIG 0	13	———
4	———	14	GND
5	SIG 1	15	———
6	———	16	GND
7	ECLK+	17	———
8	———	18	ECLK-
9	———	19	———
10	FG	20	FG

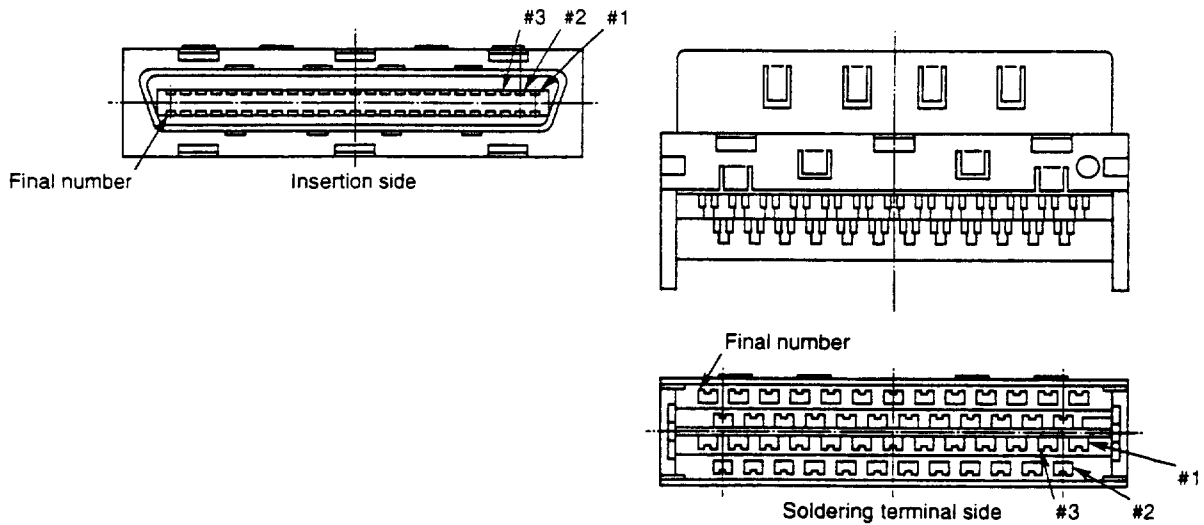

Terminal arrangement for 50 pins (Terminal arrangement for 20 pins is the same as that of 50 pins.)

c) CN4 terminal

Pin #	Signal name	Pin #	Signal name
1	PDA 1	11	PDA 6
2	PDA 3	12	PDA 8
3	PDA 5	13	AGND
4	PDA 7	14	_____
5	+10V	15	FG
6	_____		
7	_____		
8	_____		
9	PDA 2		
10	PDA 4		

Pin arrangement from the insertion side

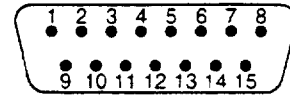

<CN4>

d) CN5 terminal

Pin #	Signal name
1	V _A
2	V _B
3	V _C
4	GND

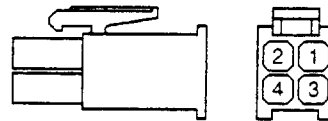

<CN5>

e) CN6 terminal

Pin #	Signal name
1	PDA 1
2	PDA 2
3	PDA 3
4	PDA 4
5	PDA 5
6	PDA 6
7	PDA 7
8	PDA 8
9	+10V
10	AGND
11	FG
12	_____

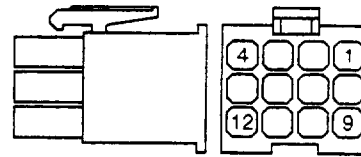

<CN6>

(7) Connections to 6000 Series Controllers/Indexers

Linearserv		6250/AT6n50	
50 Pin Connector (CN1)		Drive Connector	
---		COM	Pin 2
Servo On -	Pin 5	SHNO	Pin 4
Ready +	Pin 31	DFT	Pin 5
Com -	Pin 26	AGND	Pin 6
Agnd-TQ(Agnd-VEL)*	Pin 22(24)*	CMD -	Pin 8
Vin-TQ(Vin-VEL)*	Pin 23(25)*	CMD +	Pin 9
---		Encoder Connector	
		GND	Pin 2
Com +	Pin 1	+5V	Pin 9
A -**	Pin 41**	A +**	Pin 8**
A +**	Pin 17**	A -**	Pin 7**
B +	Pin 19	B +	Pin 6
B -	Pin 43	B -	Pin 5
Z +	Pin 21	Z +	Pin 4
Z -	Pin 45	Z -	Pin 3

NOTE:
Connect
COM to GND

* Pins 23 & 22 are CMD+/- in Torque mode(25 & 24 in Velocity mode)

**Please note that A+ and A - are swapped.

Linearserv		6200/AT6n00	
50 Pin Connector (CN1)		Drive Connector (15 pin D)	
Pulse +	Pin 15	Step +	Pin 1
Pulse -	Pin 39	Step -	Pin 9
Sign +	Pin 13	Dir +	Pin 2
Sign -	Pin 37	Dir-	Pin 10
Com +	Pin 1	Sht -	Pin 12
Servo On -	Pin 5	Gnd	Pin 14
Servo Ready +	Pin 31	Dft +	Pin 5
Servo Ready -	Pin 26	Dft -	Pin 13
		Encoder Connector	
A -**	Pin 41**	A +**	Pin 8**
A +**	Pin 17**	A -**	Pin 7**
B +	Pin 19	B+	Pin 6
B -	Pin 43	B -	Pin 5
Z +	Pin 21	Z +	Pin 4
Z -	Pin 45	Z -	Pin 3

**Please note that A+ and A - are swapped.

(8) Connection to External Controller

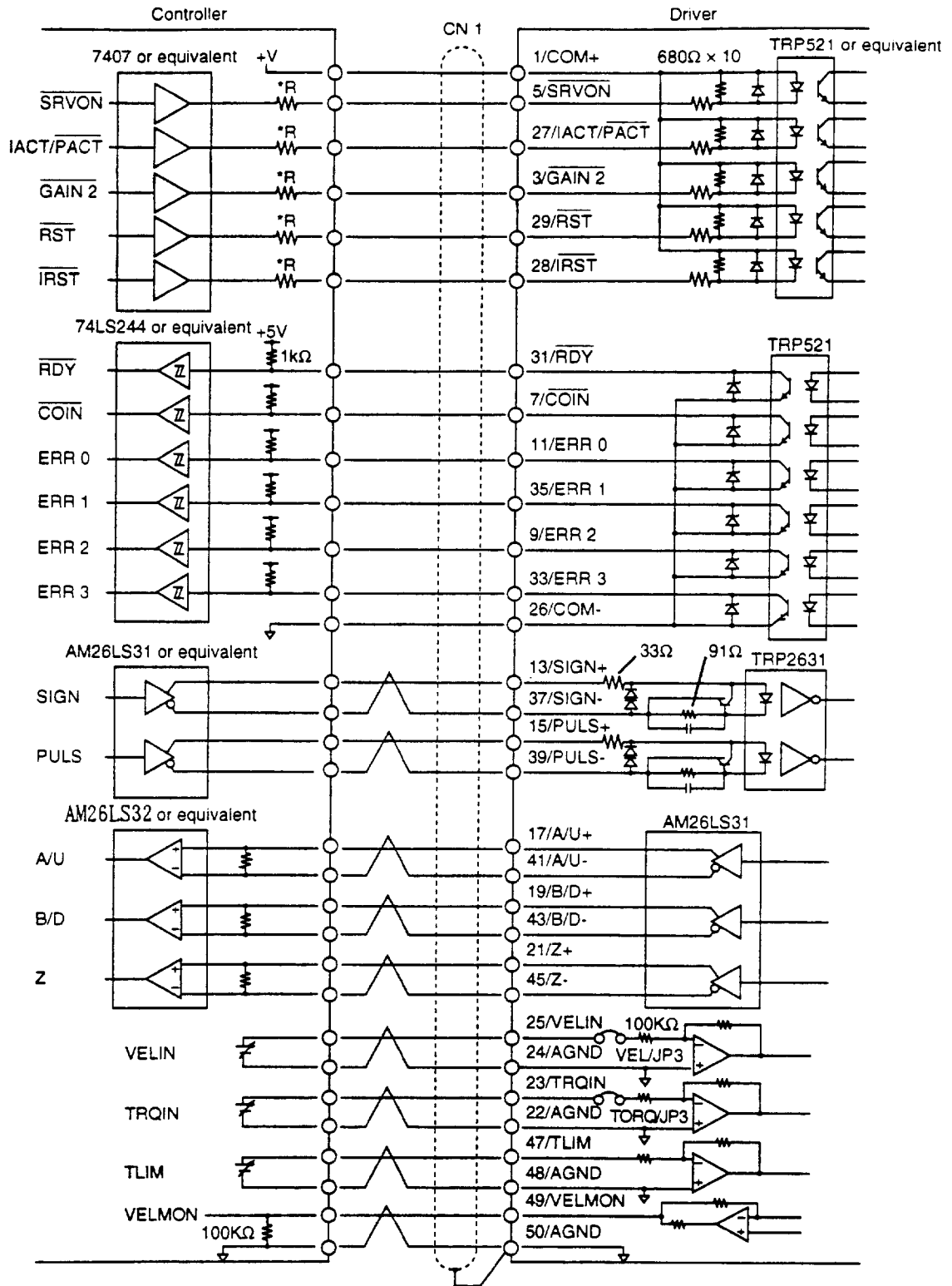

Insert a resistance of 0Ω at 5 V, 680Ω at 12 V, and 1.2 kΩ at 24 V in the circuit marked with *R.

3.4 I/O Signals

(1) **Input** (Note: Number in parentheses indicates the Vcc signal input's terminal (COM+).)

Signal name	Pin No.	Meaning	Details
COM +	1	Signal power	Usually a voltage of 5 V is entered (allowed to enter a voltage of 5 to 24 V). However, if you enter a voltage of 24 V, insert a resistance of 1.2 k Ω . (See the circuit diagram on page 3-11.)
SIGN+ SIGN-	13 37	Motor-rotating direction command	The motor rotates in the UP direction with this signal set to H and in the DOWN direction with the same signal set to L.
$\overline{\text{IRST}}$	28 (1)	Integral capacitor reset	The integral capacitor in the velocity loop is shorted.
$\overline{\text{SRVON}}$	5 (1)	Servo ON	The motor is set to the servo ON status 0.2 sec. after this signal is set to L to set the driver to the command wait status.
$\overline{\text{IACT/PACT}}$	27 (1)	Integral/proportional action selection	Integral action is selected when this signal is set to H and proportional action is selected when this signal is set to L in the position control mode.
TLIM	47 48	Current limit input	The maximum current is limited according to the input signal (analog) thus entered. The voltage between -8 and +8 V must be entered. When a voltage of -8 V is entered, it becomes the maximum thrust. If this signal is not used, always keep it open.
$\overline{\text{GAIN 2}}$	3 (1)	Gain selection	This selects the DC gain variable range. This has the same function as GAIN 2 in the SW4 switch. To use this signal, the GAIN 2 subswitch must be set to off. (see Note 1)
$\overline{\text{RST}}$	29 (1)	CPU reset	The driver control section is initialized with this signal set to L for more than 1 msec (the same status as power on status). It takes about 3 seconds to be in the operable [RDY] status.
PULS+ PULS-	15 39	Position command pulse	Driver position command pulse signal. A pulse width of 150 nsec or more is required.
VELIN	25 24	Velocity command input	This is an analog signal to enter a velocity command to the motor when this actuator is in the velocity control mode. Set to the maximum number of rotations at ± 6 V input. The input sensitivity is 2.5 V/rps.
TRQIN	23 22	Current command input	The maximum thrust is generated at ± 8 V.

(2) **Output** (Note: Number in parentheses indicates signal GND (COM-) output.)

Signal name	Pin N	Meaning	Details
COM -	26	Signal GND	
A+/U+	17	Position feedback pulse signal	Pulse signal to indicate the motor rotating position. Either A/B phase or UP/DOWN phase pulse can be selected by the jumper on the board. These are differential output signals because the velocity of frequency is very high.
A-/U-	41		
B+/D+	19		
B-/D-	43		
RDY	31 (26)	Servo ready	The motor is ready to operate with this signal set to L. This signal is set to the H level about 3 seconds after driver power on.
VELMON	49 50	Velocity monitoring	Signal for monitoring the number of motor rotations to output positive voltage for the UP direction and negative voltage for the DOWN direction. (Refer to Note 2.)
COIN	7 (26)	Positioning completion signal	This signal shows that the position deviation is within the positioning completion width. This signal is set to L when positioning is completed.
ERR 0 ERR 1 ERR 2 ERR 3	11 (26) 35 (26) 9 (26) 33 (26)	Error status output	These signals output error statuses. Generally, the RDY signal turns off as an error occurs. However, RDY signal remains as is depending on error contents.
Z+ Z-	21 45	Origin pulse	Signal for detecting the position for every pitch of glass scale (2.048 mm).

(Note 1)

GAIN 2 signal	GAIN 1 subswitch (SW4)	Gain magnification
H	OFF	x1
L	OFF	x6.6
H	ON	x14
L	ON	x20

(Note 2)

	Velocity/Volt [in/s/V (m/s/V)]
LM1000 Series	32.90 / 6 (0.8356 / 6)
LM1000* Series	6.58 / 6 (0.1671 / 6)
LM5000 Series	78.74 / 5 (2.0 / 5)

*LM1000 Series with Ultra Precision Option

3.5 Installation

When the product is delivered, first check the product type and model as well as the inclusion or absence of accessories and for the exact combination of the motor and driver.

(1) Motor Mounting

The motor can be mounted either horizontally (normal or reverse direction) or vertically. Incorrect mounting and an unsuitable mounting location may shorten the motor's service life and cause problems. Therefore, always observe the following.

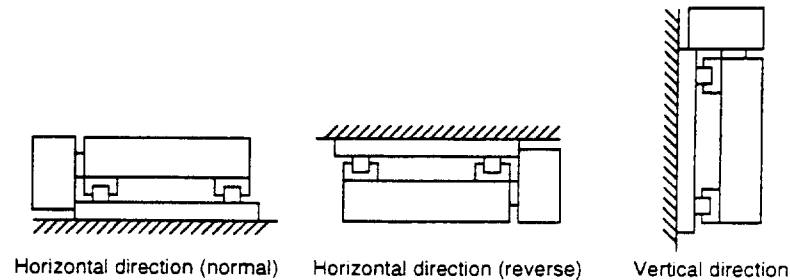

a) Installation Location

The motor section is designed for indoor use. Therefore, the installation location must be such that:

- There are no corrosive or explosive gases.
- The ambient temperature is between 0° and 45°C.
- Dust concentration is low, with adequate air ventilation and low humidity.



NOTE

The LINEARSERV is not moisture-proof or oil-proof, so it should be covered with a suitable moisture-proof or oil-proof cover.

b) Mechanical Coupling

- The flatness of the object-surface to be mounted on the slider must be maintained within a parallelism specification of less than 0.01 mm.
- The gap between the base and the slider of this system is 0.1 mm, which is extremely limited in terms of space. Hence, ensure that the base surface is free from particle dust contamination (or accumulation).
- A rust-prevention coating has been applied to the base-mount at the motor. The presence of the coating may lead to severe mechanical inaccuracies of the assembled system. Before assembling the motor, completely remove this coating using a cloth or paper dipped in a petroleum or chlorine solvent.
- Observe the following for screw-tightening torque when mounting the base and mounting the load to the slider. When tightening the screws, always apply LOCTITE 601 or the equivalent to these screws to lock them.
130 kg•cm or less for slider; 40 kg•cm or less for base
- The accuracy of the motor is influenced by the levelness of the mounting surface at the base. Hence, it is necessary to obtain the best levelness of the mounting surface.

(2) Driver Mounting

The standard driver is designed for rack mounting or wall mounting.

a) Installation Location

- If there is a heat generating source near the installation location, ensure that temperature does not exceed 50°C in the proximity of the driver by providing an appropriate heat shield or cover, etc.
- If there is a vibration generating source near the driver, then mount the driver on the rack with appropriate vibration insulators.
- Further, installation must be at a location where the humidity is low, and where the surrounding environment is free from high temperature and humidity, dust, metal powders or corrosive gases.

b) Mounting Procedure

- Normally, the driver is rack-mounted (with angle brackets) on a level plane with the front panel facing forward. However, it may be mounted with its driver panel facing upward. Always avoid mounting it with the panel turned on its side or upside down. (See the figure below.)
- The driver box adopts a natural air-cooling system. To mount it, make sure there is a clearance of more than 25 mm above and below the box for ventilation. The self-power loss of the driver is approximately 30 W. (See the figure below.)

**CAUTION**

Never use screws having a length of 6 mm or more to fix the clamps to the driver box to avoid damaging the controller board.

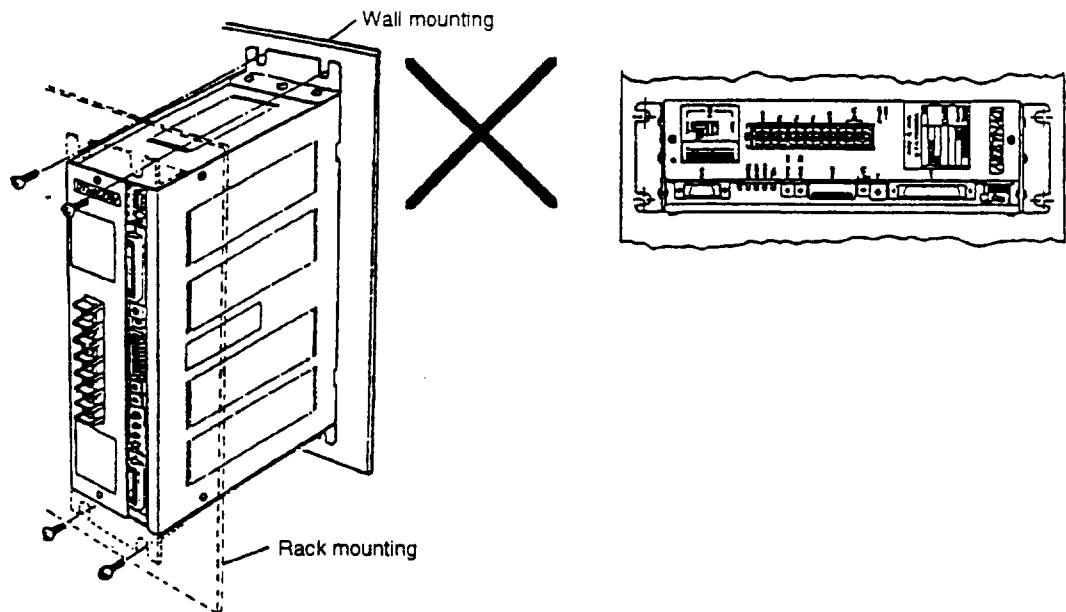

(3) Fixing Cables to the Slider

Power and encoder cables are coming out of the two connectors at the slider. For slider installation, fix the cables to the side of the slider. The screw holes are provided at two places on the side of the slider to fix the cables (see the figure at right - cable leadout to the right. See attached drawings for the other models)

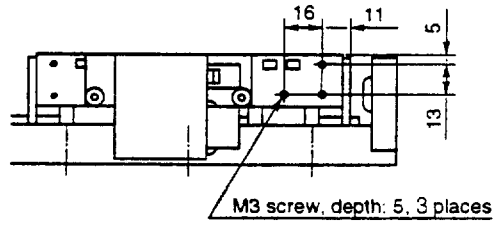

3.6 Service Life

The service life of the motor of the DYNASERV is determined by that of the four linear guides provided at the driver. The following shows the rated loads of the linear guides:

Load	LM1050/1100, LM5040/5090	LM2050/2100, LM3040/3090	LM1300/5270
Basic dynamic rated load: C	2000N	4700N	8330N
Basic static rated load: Co	3000N	8530N	13500N

The attracting force of the magnetic circuit applies to the motor as follows:

LM1050 series: 400N; LM110 series: 900N; LM1300 series: 2400N

Therefore, one-fourth of the attracting force applies to each linear guide. According to the above, the service life of the motor can be obtained according to the following equations assuming that L is the distance:

<Example>

LM1050 series: $L = 50(1600/(100+P))^2$ [km]



LM1100 series: $L = 50(1600/(225+P))^2$ [km]

However, $P[N] = \text{Load quality [kg]} \times 9.8$ [m/s²]

If the load applies to the center of the slider, assume that one-fourth of the load applies to each guide. Adding the four loads makes the value of P. If the load is not in the center of the slider, see the diagrams on the right. In this case, dimensions f and c between guides should conform to the table below.

Model	f (mm)	c (mm)
LM1050/5040	76	55
LM1100/5090	76	76
LM1300/5270	125	125
LM2050/3040	91	72
LM2100/3090	91	93

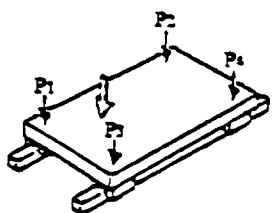
Equations to Obtain Loads Depending on Load Position

Example of load position	Guide position	Equation
(1) Two horizontal-axis vertical loads 	$P_1 = b/c \cdot d/f \cdot F$ $P_2 = b/c \cdot d/f \cdot F$ $P_3 = a/c \cdot d/f \cdot F$ $P_4 = a/c \cdot d/f \cdot F$	
(2) Two horizontal-axis vertical overhanging loads 	$P_1 = b/c \cdot d/f \cdot F$ $P_2 = b/c \cdot d/f \cdot F$	

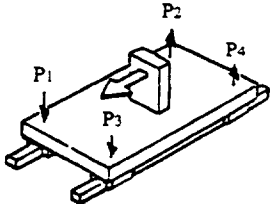
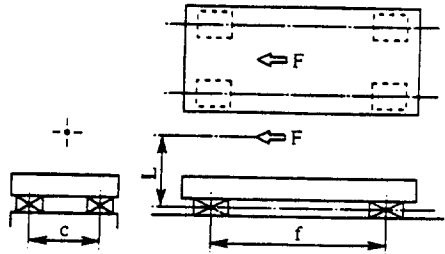
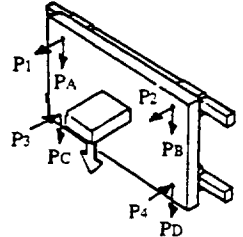
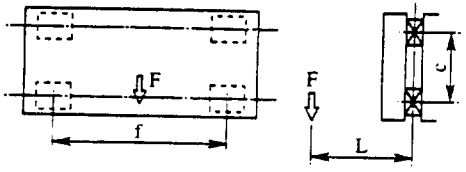
Example of load position	Guide position	Equation
<p>(3) Two horizontal-axis horizontal loads</p> 		$P_1 = 1/2 \cdot L/f \cdot F$ $P_2 = -1/2 \cdot L/f \cdot F$ $P_3 = P_1$ $P_4 = P_2$
<p>(4) Two axes on the vertical guide plane vertical load</p> 		$P_1 = -1/2 \cdot L/c \cdot F$ $P_2 = P_1$ $P_3 = 1/2 \cdot L/c \cdot F$ $P_4 = P_3$ $P_A = P_B = P_C = P_D = F/4$

Note: F: Load [N]

a, b, c, d, e, f, L: Distance [mm]

P1, P2, P3, P4: Vertical load on bearing [N]

PA, PB, PC, PD: Lateral load on bearing [N]

Static safety factor

Generally, we consider the basic static load as the permissible limit of the static load. However, its limit is determined depending on the operating conditions of and required conditions to the bearing. The static safety factor f_s in this case is obtained according to the following equation:

$$f_s = C_0/P_0 \quad (C_0: \text{Basic static rated load [N]}; P_0: \text{Static load [N]})$$

Set the f_s value to 5 or greater in this LINEARSERV.

Therefore, the maximum static load (F) of the motor is:

$$F < 4C_0/f_s - F_M \quad (F_M: \text{Attracting force})$$

3.7 Definitions and Measurement Methods of Specification Accuracies

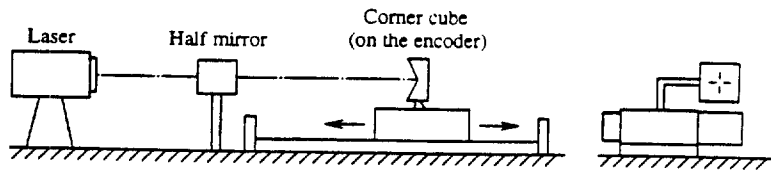
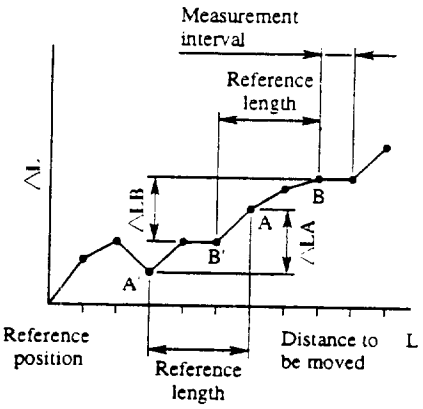
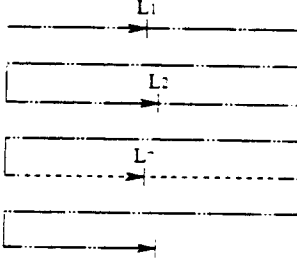
Item	Specification value	Definition and measurement method
Positioning accuracy	10 μ m(P-P)	<p>■ Measurement by laser interferometer</p>  <p><Positioning accuracy> Positioning should be made sequentially from a reference position in a direction, and then measure the difference between the actually moved distance and the one to be moved at each position to obtain the maximum difference within each reference length. This measurement should be done in the total moving distance with a specified interval. These maximum values thus obtained are taken as measured values.</p> <p><Repeatability> Determine an arbitrary point for positioning and repeat positioning seven times with the same direction in order to measure stop positions, and then obtain a half of the maximum difference of the reading. As a rule, this measurement should be done at the center of the distance to move or at both side positions. Of these values obtained, the maximum one is taken as the measured value. Represent the accuracy by adding a \pm sign to the half of the maximum value.</p>
	Repeatability $\pm 0.5\mu$ m	  <p>$\Delta L = (\text{actually moved distance}) - (\text{command value of distance to be moved})$</p>

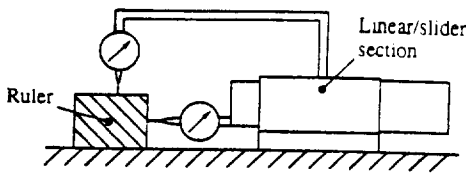
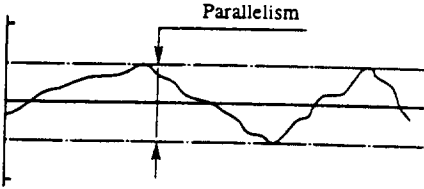
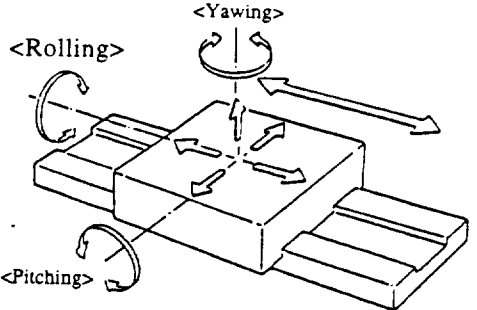
Item	Specification value	Definition and measurement method
Mechanical accuracy	Parallelism	<p>■ Measurement by dial gauges</p> <p><Parallelism> Deflection of the gauges on the vertical and horizontal directions on table moving axis</p>  <p>(Measured values are indicated by two direct lines in parallel. Parallelism is the distance between the maximum and minimum measured values (the range indicated by two direct lines in parallel).)</p> 
	Pitching Yawing Rolling	<p>■ Measurement by autocollimator (indicated by the maximum difference of measurement reading)</p> <p><Pitching> Angle change in the vertical direction on table moving shaft</p> <p><Yawing> Angle change in the horizontal direction on table moving shaft</p> <p><Rolling> Angle change about the table moving shaft</p> 

4. CAUTION ON OPERATION

4.1 Cautions on I/O Signals

(1) Position Command Pulse Input Signal (PULS±)

This is the driver position command pulse signal. The pulse signal uses positive switching logic with a minimum pulse width of 150 ns. This signal should be connected upon the position control mode.

(2) Motor Rotating Direction Command Input Signal (SIGN±)

This is the signal that indicates the motor rotation. The motor rotates clockwise when this signal is set to H and counterclockwise when this signal is set to L. The timing of this signal with respect to the position command pulse signal at the output is as shown below:

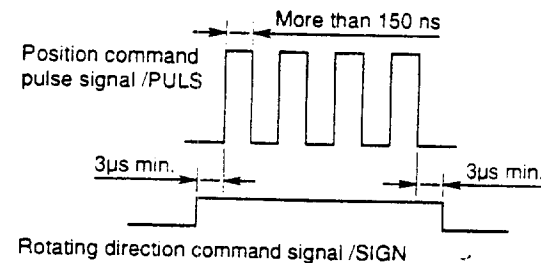

Note: The pulse should be set to active H. This means that there is no current flowing through the driver photocoupler if a pulse is not output.

(3) Velocity Command Input (VELIN)

This is connected when the signal is in the velocity control mode. An analog input signal is used as the motor rotating velocity command value. The motor rotates clockwise when a positive voltage is supplied and counterclockwise when a negative voltage is supplied. (Input range: -10 to +10 V; input impedance: 100 kΩ)

(4) Current Command Input (TRQIN)

This is connected when the signal is in the thrust mode. An analog input signal is used as the motor current command value. The motor rotates to the UP direction when a positive voltage is supplied and to the DOWN direction when a negative voltage is supplied. Upon the position control mode, this command can be used as a thrust feedforward signal.

(5) Current Limit Input (TLIM)

This is an analog signal to limit (regulate) the motor current.

(6) Velocity Monitoring Output (VELMON)

Motor analog velocity monitoring output

Output voltage: At maximum velocity +6 V (UP direction)

At maximum velocity -6 V (DOWN direction)

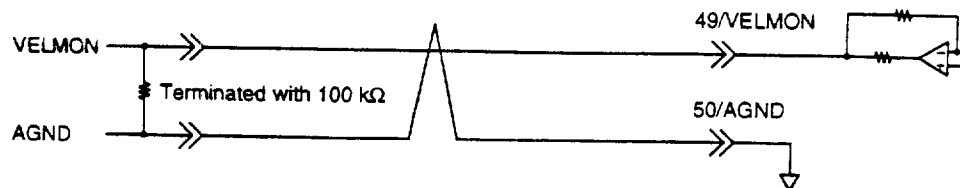

(7) A/B Phase, UP/DOWN Pulse Output Signals (A/U±, B/D±)

Pulse signals to indicate the motor position. The following two pulse output statuses can be selected by jumpers on the controller board.



NOTE

As the 0.1-μm version outputs signals after averaging, a delay occurs to the actual motor position.

a) A/B Phase Output Pulse

The following pulse signal is output with the jumper [UD/AB] on the controller board shorted.

	DOWN direction	UP direction
A-phase pulse		
B-phase pulse		

b) UP/DOWN Output Pulse

The following pulse signal is output with the jumper [UD/AB] on the controller board opened.

	DOWN direction	UP direction
UP-pulse signal		

(8) Origin Pulse Output Signal (Z±)

This is the signal for detecting the original position provided on each stroke (2.048 mm)* of the motor. When the original position is detected, the next pulse signal is output. The point at which H changes to L when the motor rotates to the UP direction, or L changes to H when the motor rotates to the DOWN direction, corresponds to the original position. The accuracy of origin pulse depends on that of the motor. The characteristics of the origin pulse signal are as shown in the diagrams on the below. The origin repeatability upon positioning control is influenced by the following items:

- Origin return algorithm *(High speed model : 4.096mm)
- Position control system
- External vibration
- Control gain

When the motor rotates to UP direction: 200µs or more



When the motor rotates to DOWN direction: 200µs or more

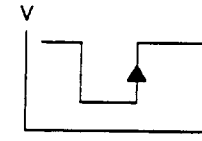

<Origin pulse signal and zero position>

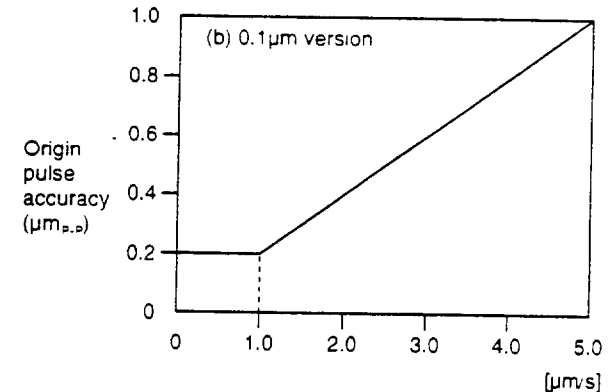
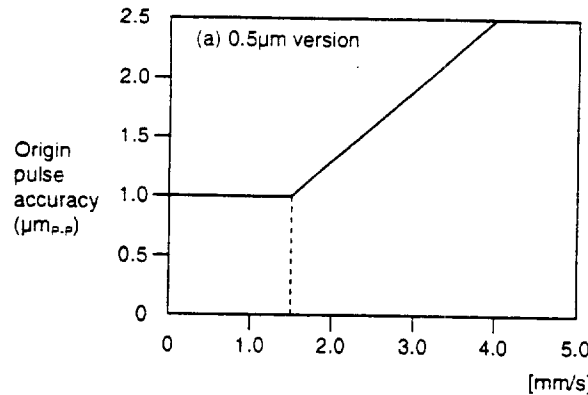

<Relationship between motor velocity and pulse accuracy>

In the 0.1-µm version, since the feedback pulse signal that is equalized in the servo driver is output, it is not synchronized with the origin pulse signal. Thus, if the controller does an origin return, select the method which does not use feedback pulse. If feedback pulse is used, the origin return accuracy may be insufficient.

<Example of origin return>



(9) **ERR Output Signal**

ERR 0 to 3 show the driver statuses. For details, see Section 7.2, "LED Displays." Since these signals are updated every 20 msec, take proper actions to prevent misreading if the signals are read by the controller (double reading, etc.)

4.2 Power On/Off

Pay special attention to the following when the power is turned on.

- (1) The inrush current in both the main and control power circuits is about 20 A (100 V AC source) peak.
- (2) The motor is set to the servo status about 200 ms after the SRVON signal is set to L. At this time, serial pulse input becomes effective.
- (3) After the power supply is turned on, the RDY=H condition is maintained up to 3 seconds.

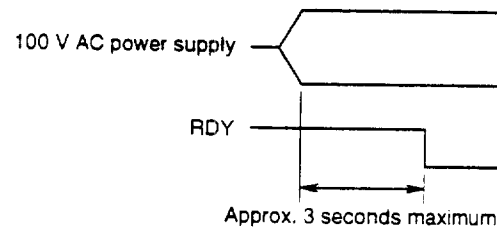

5. CONTROL MODE AND ADJUSTMENT

5.1 Position Control Mode Adjustment

In the position control mode, motor positioning control is performed according to the command position sent from the higher-level controller. Two control methods are available in the velocity control mode: the I-PD control system is selected with the CN1 connector [LACT/PACT] signal set to H, and the P control system, with the same signal set to L. Usually, the I-PD control system is selected in the positioning mode of operation.

(1) I-PD Position Control

This method uses position integral feedback and is suitable for highly accurate positioning. A stable control characteristic is also achieved even under load variations. In this mode, adjustment of the fc switch, I-LIM switch, and DC gain adjustment control becomes necessary.

a) fc switch (Natural frequency adjustment switch)

The 1 to 16 Hz position control system band is selected from a scale of 0 to F.

b) I-LIM switch (Integral limiter adjustment switch)

This prevents the wind-up phenomenon by limiting the output of the digital integrator during software servo computation. The larger the switch number, the larger the limited value. The smaller the limited value, the smaller the wind-up and the shorter the settling time. However, if the limited value becomes too small, the motor output torque is also limited. Therefore, it is better to make the switch value large within no wind-up range. Fine adjustment is performed during the acceleration/deceleration operation. If this value is inappropriate, an overcount alarm may occur.

c) DC gain adjustment control

The combination of the GAIN 1 and 2 subswitches with DC GAIN adjustment control in the SW4 setting switch provided at the front panel results in an adjustment range from 0.5 to 110 times. The DC gain should be as large as possible. If there is a change in inertia, adjust the gain so that it reaches the optimum at the maximum load.

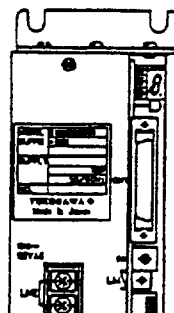

(2) P Position Control

Positioning accuracy is not high because proportional control is used for positioning feedback. The velocity controls which can be set for simultaneous selection are P and I controls, and they can be set with a jumper.

With P velocity control (P-P type), torque which is proportional to the positioning error is obtained, and compliance control is possible. In this control mode, only the fc switch and DC gain control are to be adjusted.

With I velocity control (P-I type), high tact positioning can be achieved. In this control mode, the fc switch, DC gain control, and AC gain control are to be adjusted.

(3) Position Control System Adjustment Procedure (see the following figure)

The position control system can be adjusted in the test mode. Turning on the test switch at the front of the driver generates a 2.5Hz square-wave position command signal inside the driver to output the motor position to the POSN signal terminal. At this time, ensure that the motor exhibits reciprocal action at very small rotating angles.

① The adjustment procedure for I-PD position control in the test mode is as follows:

Step 1: Connect an oscilloscope to the POSN signal terminal.

Step 2: Set the CN1 connector SRVON signal to L. At that time, set the TEST subswitch to off.

Step 3: Set the TEST subswitch at the front of the driver to on.

Step 4: Adjust the fc switch. Its variable range is from 1 to 16 Hz and should be set to about 10 Hz (scale graduation: 9) under normal load conditions. Set the I-LIM switch to a large value within the range in which there is no hunting. Select the GAIN 1 or 2 subswitch in accordance with the load condition. Fine adjustment is made by DC gain control. Perform the above adjustments so that the POSN signal becomes a square wave.

Step 5: Set the TEST subswitch at the front of the driver to off.

Step 6: Set the CN1 connector SRVON signal to H.

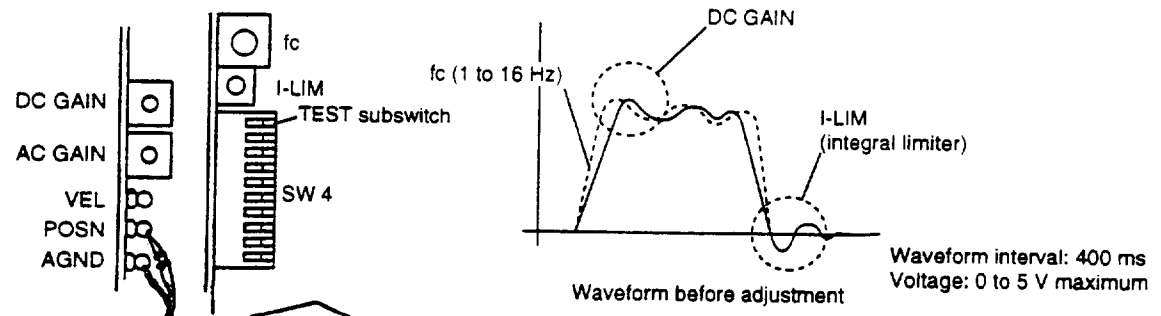

② The adjustment procedure for P-I type position control in the test mode is as follows:

- Step 1:** Connect an oscilloscope to the POSN signal terminal.
- Step 2:** Set the CN1 connector SRVON signal to L. At that time, set the TEST subswitch to off.
- Step 3:** Set the TEST subswitch at the front of the driver to on.
- Step 4:** Adjust the f_c switch. Its variable range is from 1 to 16 Hz. Set AC gain control to a large value within the range in which there is no hunting. Fine adjustment is made by DC gain control. Perform the above adjustments so that the POSN signal becomes a square wave.
- Step 5:** Set the TEST subswitch at the front of the driver to off.
- Step 6:** Set the CN1 connector SRVON signal to H.

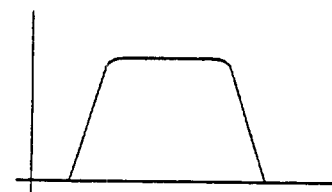
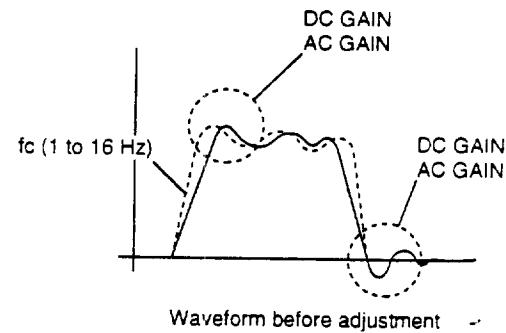

Waveform after adjustment (optimum waveform)

(4) Procedure for Adjustment Without Measuring Instruments

The preceding demonstrated procedures for making adjustments while monitoring the waveform; this section demonstrates an adjustment procedure that does not use any measuring instruments. These adjustment methods are valid only in the case of the position control mode (I-PD type, the setting upon shipment). Make the adjustment according to the following order:

- 1) Calculate the load $\langle W \rangle$ [kg].
- 2) Set the f_c switch on the driver front panel to ON.
Position band frequency $\langle f \rangle$ is $(f_c + 1)$ [Hz]. Usually, set the switch to near "9."
- 3) Calculate the value of DC gain.

	LM1000 Series		LM1000* Series	
	LM1050	LM1100	LM1050*	LM1100*
DC GAIN	$f_p/4*(1.2+W)$	$f_p/8*(1.4+W)$	$f_p/20*(1.2+W)$	$f_p/40*(1.4+W)$

	LM1000 Series		LM1000* Series	
	LM1300		LM1300*	
DC GAIN	$f_p/24*(5+W)$		$f_p/120*(5+W)$	

* LM1000 Series with Ultra Precision option

	LM5000 Series		
	LM5040	LM5090	LM5270
DC GAIN	$3*f_p/4*(1.2+W)$	$3*f_p/8*(1.4+W)$	$3*f_p/24*(5+W)$

Example: When $\langle W \rangle = 10$ [kg] and $f_c = 10$ [Hz] in LM1050;
DC GAIN = $11/4 * (1.2 + 10) = 30$

- 4) Set the value of DC GAIN calculated in 3) above using the SW4 switch and the DC gain control.

SW4 switch

GAIN 1	GAIN 2	Gain magnification
OFF	OFF	x1
OFF	ON	x6.6
ON	OFF	x14
ON	ON	x20

DC gain control

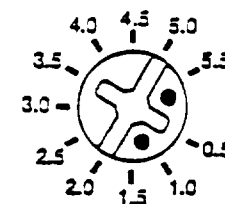

Example: To set GAIN magnification to x30, set the SW4 switch to "x20" and then the DC gain control to "1.5." This results in $20 \times 1.5 = 30$.

Generally, a satisfactory result can be obtained by setting the setpoint a little greater than the calculated value.

- 5) $\langle LIM \rangle$ switch setting

Usually set the $\langle LIM \rangle$ switch to "3 to 4." If you make the setpoint smaller, the

5.2 Velocity Control Mode Adjustment

In the velocity control mode, the motor rotating angle is controlled so as to correspond to the velocity command voltage (-10 to +10V) from the higher-level controller. The two control methods can be selected in the velocity control mode. The following table shows the relationship between the velocity command voltage and motor velocity.

	Velocity/Volt [in/s/V (m/s/V)]
LM1000 Series	32.9/6 (0.8356 / 6)
LM1000* Series	6.8/6 (0.1671 / 6)
LM5000 Series	78.7/5 (2.0 / 5)

*LM1000 Series with Ultra Precision Option

(1) PI Velocity Control

The use of integral/proportional action in velocity control achieves smooth and disturbance-resistant control. This is the same control mode used in a conventional DC/AC servo motor control. In this control mode, only the DC gain and AC gain adjustment controls are adjusted.

a) DC gain

The combination of the driver's GAIN 1 and 2 subswitches in the SW4 switch results in an adjustment range of from 0.5 to 110 times.

b) AC gain

Velocity loop band damping is adjusted.

(2) P Velocity Control

Since velocity control is effective only in proportional action, response is fast but is strongly influenced by disturbances in the controlled motor. In this control mode, DC gain control at the front of the driver and the GAIN 1 and 2 subswitches in the SW4 are adjusted.

(3) Adjustment of Velocity Control System

Adjustment of the velocity control system can be carried out in the test mode. By turning on the TEST subswitch at the front of the driver, a 2.5Hz square waveform signal is applied to the velocity input in the driver, and the motor starts moving back and forth, repeatedly, at a small rotating angle. Under this condition, observe the VEL signal on the front panel on an oscilloscope, and adjust the DC gain and AC gain so that the VEL signal becomes an optimum waveform as shown in the figure below.

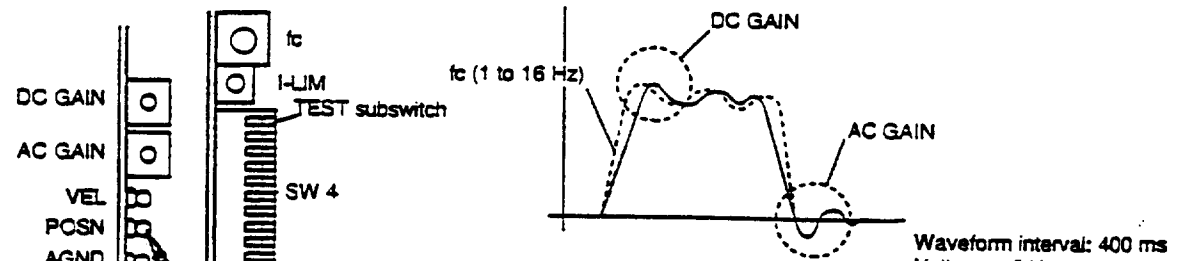

5.3 Thrust Control Mode Adjustment

In the thrust control mode, current flows through the motor corresponding to the current command voltage (-8 to +8 V) from the higher-level controller. Motor output thrust depends on the current. Therefore, thrust is 0 at 0 V of command voltage, and the maximum thrust is produced at 8 V.



NOTE

When desirous of using the thrust control mode, carefully plan and design the velocity and position control loops and a proper interlocking system so that the final control system meets the exact specifications of the application.

5.4 Mechanical Resonance Notch Filter Adjustment

The following explains the adjustment procedure when a mechanical resonance notch filter is installed as an option. The board of the filter is located as shown in the figure below just inside the square cut-out on the side of the driver. Controls f_1 and f_2 on the board are used to set the notch frequencies at the first and second stages, respectively. The frequencies can be set within the range from 150 Hz to 1.5 kHz (the frequencies are factory-set to 1.5 kHz when shipped).

Use controls Q_1 and Q_2 to change the setting of the Q values. The Q values can be set within a range from 0.5 to 2.5 (0 to 20 k Ω) (the Q values are factory-set to 2.5 when shipped).

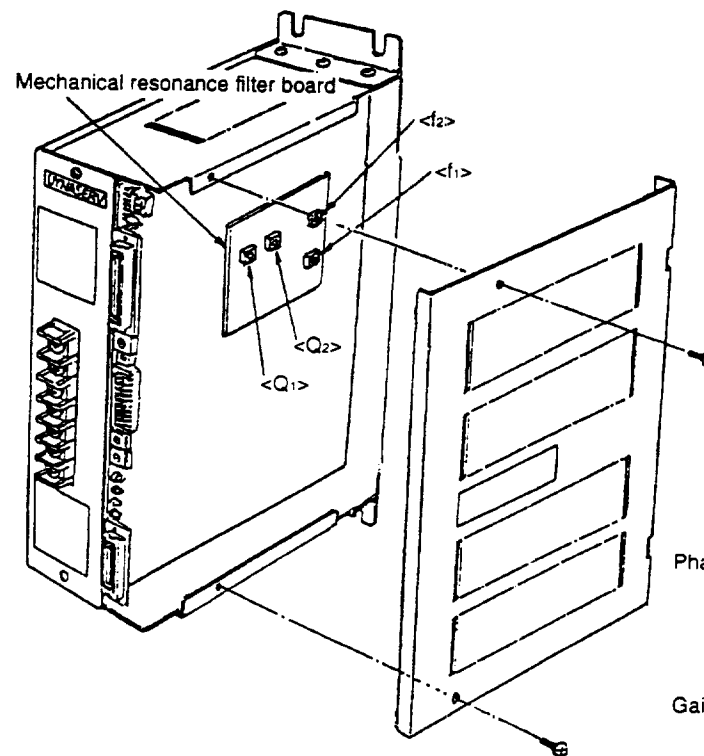

f_1 and f_2 adjustment controls

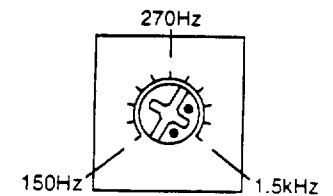

Q_1 and Q_2 adjustment controls

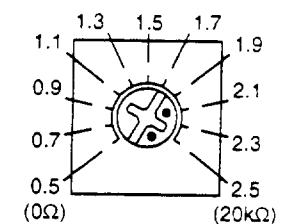

Phase (Deg.)

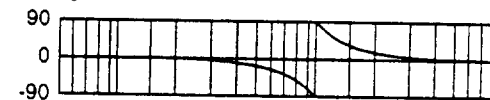

Gain (dB)

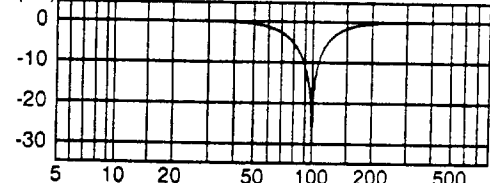

Notch frequency: 100 Hz
Q=2.0

6. MAINTENANCE AND INSPECTION

6.1 Motor

Only simple daily checks need be carried out on the motor. Check for noise or excessive vibration which is not normal. Never disassemble the motor. If the condition of the motor is not normal after 20,000 hours of use or five years after installation, replace the motor together with the servo driver, if necessary. This time period may vary depending on the environmental and operating conditions where the motor is used.



CAUTION

It is absolutely imperative to lubricate the motor (at specific locations as shown in the figure the below) with the specified lubricating grease only, either after every run of 100km, or after every 3 months of usage, whichever occurs first.

If the lubricating points are inaccessible due to some reason, then use the specified lubricating grease on the guide – rails instead.

As the type of grease lubricant varies with the model of motor, kindly contact the manufacturer or it's authorized distributor for recommended products.

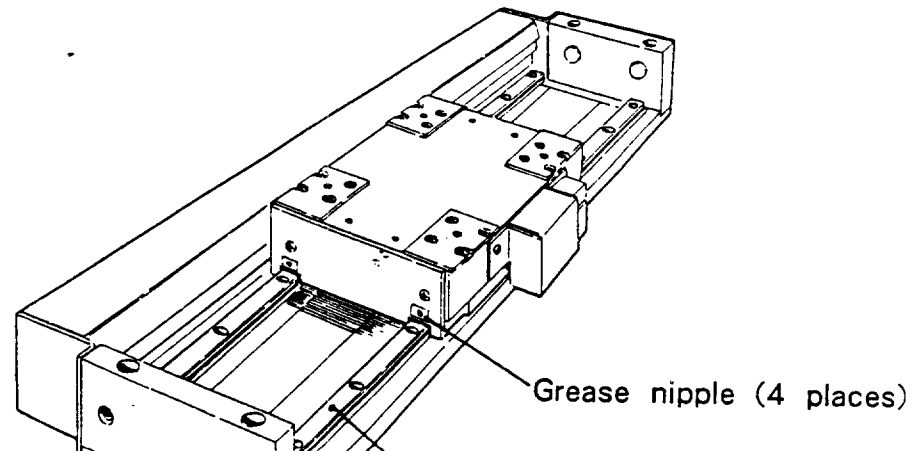

7. TROUBLESHOOTING AND MEASURES

7.1 Motor Problems and Measures

Whenever any abnormal condition occurs while operating the motor, check the LED display on the front panel of the driver first. If the cause of the abnormal condition is not determinable by the LED indicated on the display, take the appropriate countermeasures shown in the table below. If the motor still does not function normally, even after the following measures have been taken, immediately cease operation and consult Parker-Compumotor (800-358-9070).

Problem	Estimated Cause	Inspection Item	Measure	Page(s) for Reference
The motor is not servo-locked.	■ No AC power is being fed.	Wiring	Turn on the specified AC power	3-6, 3-7
	■ The servo ON (SRVON) terminal is set to H.	Inspection	Set to L	3-12
	■ The CPU reset (RST) terminal is set to L.	Inspection	Set to H	3-12
	■ The integral capacitor reset (IRST) terminal is set to L.	Inspection	Set to H	3-12
	■ fc, I-LIM, or DC gain is too small.	Inspection	Adjust to the appropriate value	5-1 - 5-4
The motor does not start.	■ Overloaded	Operation of the motor with no load.	When starting the motor, lighten the load or replace the motor with a larger output motor.	
	■ Incorrect external wiring	Inspection of wiring	Re-wire correctly by referring to the connection diagram.	3-6, 3-7
	■ fc, I-LIM, or DC gain is too small.	Inspection	Adjust to the appropriate value	5-1 - 5-4
Motor rotation is	■ Inverter M			

Problem	Estimated Cause	Inspection Item	Measure	Page(s) for Reference
Abnormally small motor thrust	■ Incorrect motor/driver combination	Check of combination numbers on the nameplate.	If the combination is wrong, then return to the appropriate combination.	1-3
	■ Overloaded	Check the OVL signal.	Recheck the operation. Lighten the load.	3-12, 3-13
	■ fc, I-LIM, or DC gain is too small.	Inspection	Adjust to the appropriate value	5-1 - 5-4
The motor runs out of control.	■ Incorrect motor/driver combination	Check of combination numbers on the nameplate.	If the combination is wrong, then return to the appropriate combination.	1-3
	■ Improper jumper setting	Inspection	Perform correct jumper setting.	3-1 - 3-5
	■ Improper connection	Check of motor/encoder connection.	Re-wire correctly by referring to the connection diagram.	3-6, 3-7
Position is out of kilter.	■ Incorrect A/B-phase and U/D pulse jumper selection	To be inspected		3-1 - 3-5
	■ Command pulse rate and width are not as specified.	Check the command pulse width.		4-1 - 4-4
	■ Feedback pulse rate and receive circuit response speed are not as specified	Check the feedback pulse rate (3 MHz max.) and receive circuit response speed.		4-1 - 4-4
	■ Neither end of the feedback pulse transmission cable shield is connected to the ground	To be inspected. If so, connect the driver to AGND and the controller to SG.		
The motor does not return to its origin accurately.	■ Connection with unmatched controller	Check the method for returning the motor to its origin and reconfigure the settings.		
	■ Improper positioning of the "around-the-origin" sensor	Observe the positional relationship of the accuracy-marker edge of the "around-the-origin" sensor signal with the one for the origin signal using an oscilloscope to ensure that these two edges do not overlap.		
	■ Chattering in origin signal	Check for any chattering in the origin signal. Increasing the speed of the return-to-origin signal helps prevent chattering from occurring. If chattering still persists, adjust the position of the "around-the-origin" sensor. (If the reverse-going edge appears first, you may confuse it with the accuracy-marker edge.)		

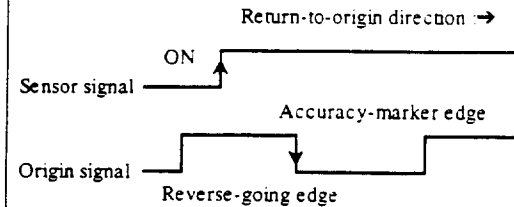

7.2 LED Displays

A 7-segment LED is mounted on the front panel of the driver to display the normal/abnormal status of the motor and driver. An error signal is output at the same time. Display details are as shown in the following tables.

LED display		Display details with TEST subswitch on	Output signal					Status	Estimated cause	Possibility of recovery
Servo			ERR				R D Y			
OFF	ON		3	2	1	0				
0	0.	—	L	L	L	L	L	Normal display		
1	1.	—	L	L	L	H	L	Overspeed	Motor velocity exceeds 125% of its maximum velocity.	Possible
2		—	L	L	L	L	H	RAM error	RAM read/write error	Impossible
3		0000-0002	L	L	H	H	H	Encoder error	Encoder signal level has dropped. See "Procedure for Error Correction."	Impossible
		0006-0009							Encoder signal having abnormal intervals is entered. See "Procedure for Error Correction."	
6		—	L	H	H	L	H	Over count, shut down	Effective only upon option setting	Impossible
								L	Counter overflow	
7		—	L	H	H	H	H	ROM error	ROM checksum error	Impossible
8		—	H	L	L	L	H	Main power supply dropped	Input AC power supply voltage has dropped.	Possible
9.		—	L	L	L	L	H	Driver reset	Driver reset status	Possible
9		0000	H	L	L	H	H	CPU error	Watchdog timer (WDT) error	Impossible
A		—	H	L	H	L	H	Overcurrent error	Excessive current flows through the motor.	Impossible
C	C.	—	H	H	L	L	L	Overload	Motor input power exceeds the specified value. The motor current becomes 1/2.5 as detection is done.	Possible
E		—	H	H	H	L	H	Overvoltage	Excessive voltage is entered into the driver or excessive load is made to rotate at high speed.	Impossible

Note: Consult Yokogawa Precision Corporation or its authorized agency for cases where recovery is impossible.

(1) Encoder error

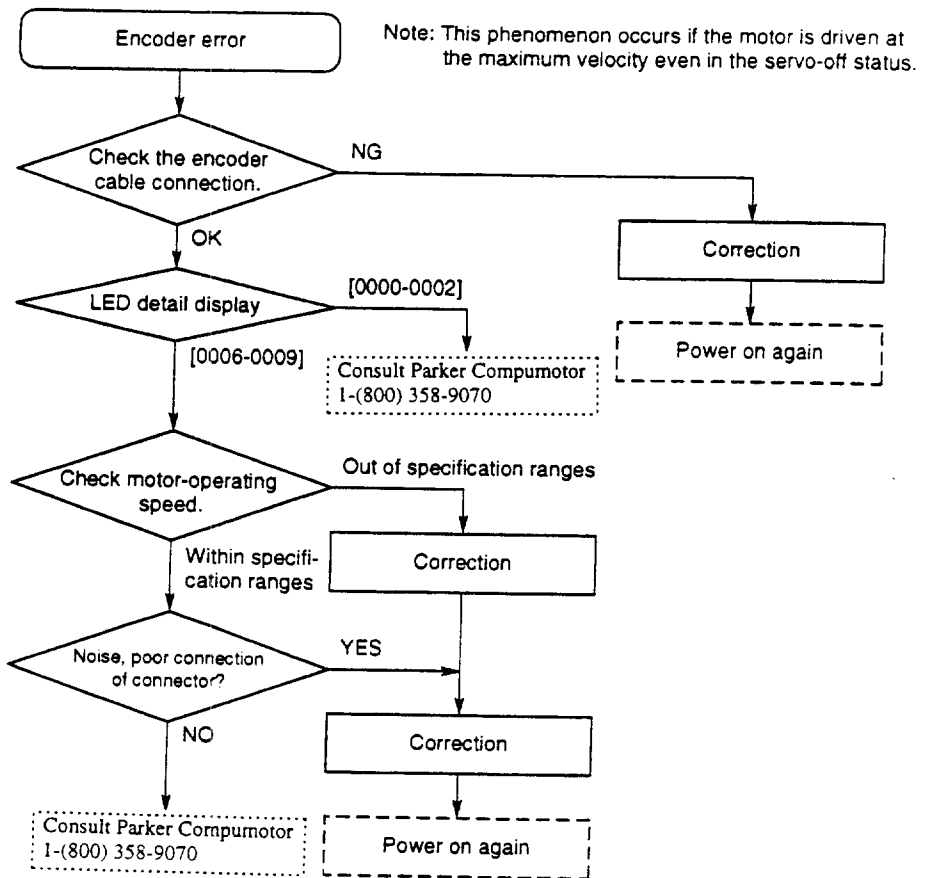

(2) Overspeed

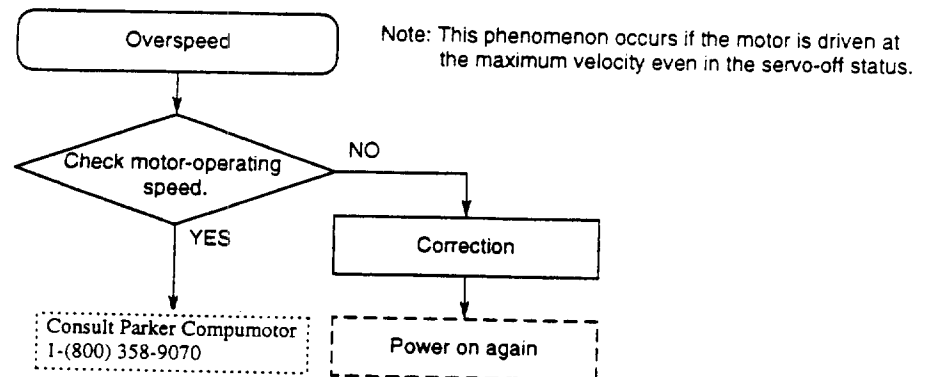

(3) Overcount

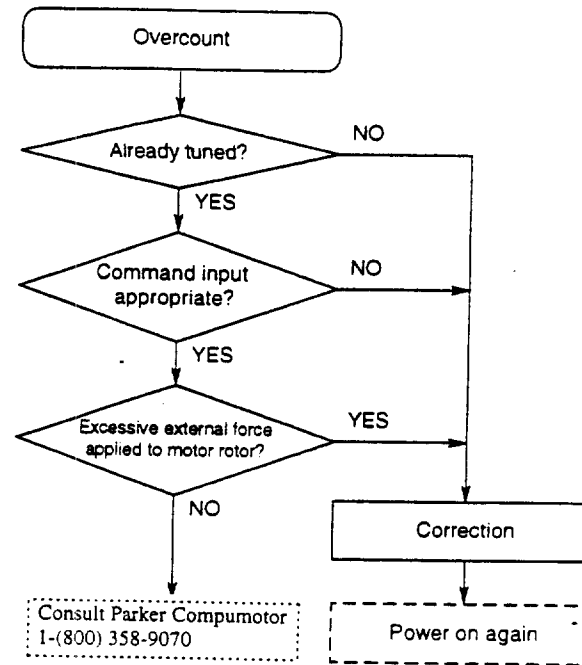

Note: The position deviation exceeds 16.4 mm in the position control mode.
 This phenomenon tends to occur if the motor is driven at the maximum velocity or if the < j LIM > switch is set to too high a value.

(4) Main power supply lowered

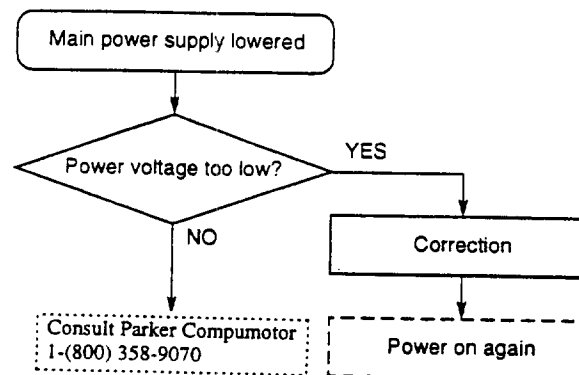

(5) Overvoltage, Overcurrent

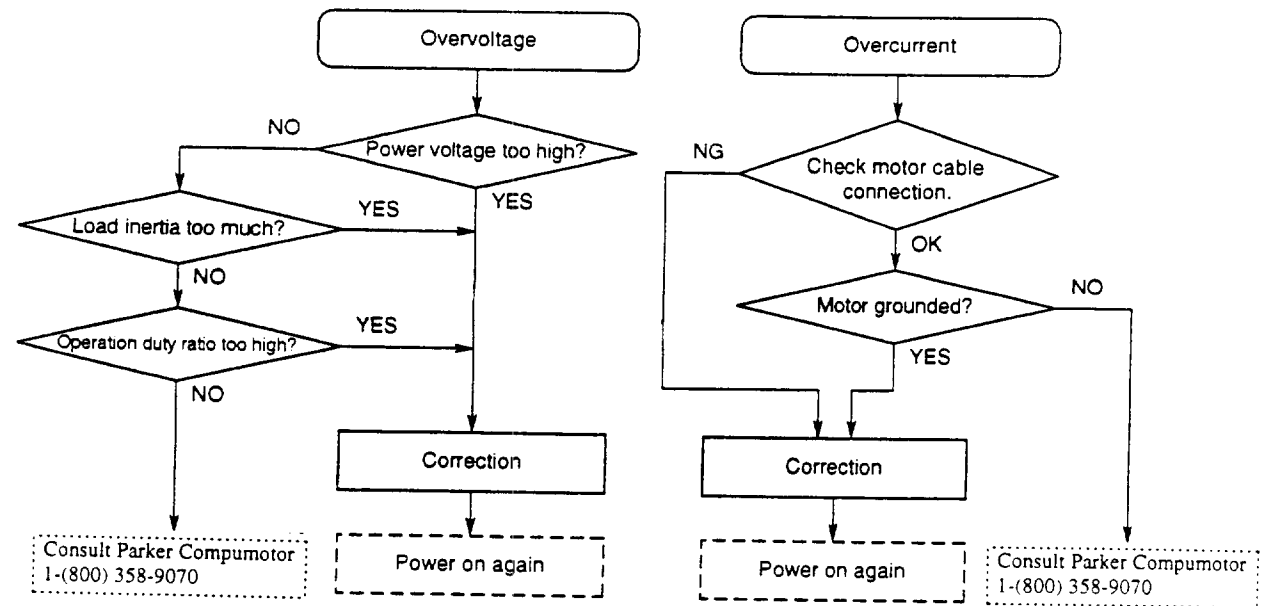

(6) Overload

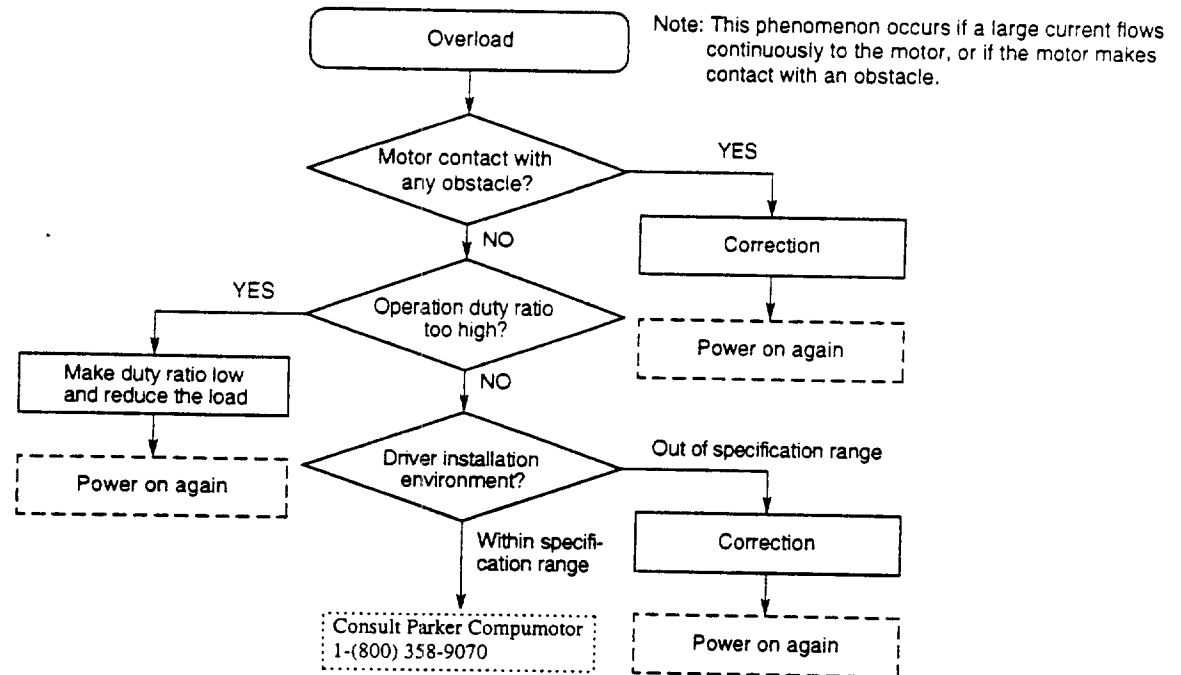

8. REFERENCE

8.1 Standard Specification

LM1000 Series Motor Specifications

		LM1050	LM1100	LM1300
Performance				
Maximum force	lb	11.25	22.5	67.5
	N	50	100	300
Positional accuracy ^a	in x 10 ⁻⁴	3.9 ^c	3.9 ^c	3.9 ^c
	μm	10 ^c	10 ^c	10 ^c
Maximum speed	in/s	32 (6) ^a	32 (6) ^a	32 (6) ^a
	m/s	0.83 (0.16) ^a	0.83 (0.16) ^a	0.83 (0.16) ^a
Encoder resolution	in x 10 ⁻⁵ /pulse	1.95 (0.39) ^a	1.95 (0.39) ^a	1.95 (0.39) ^a
	μm/pulse	0.5 (±0.1) ^a	0.5 (±0.1) ^a	0.5 (±0.1) ^a
Repeatability	in x 10 ⁻⁵	±1.95 (±0.39) ^a	±1.95 (±0.39) ^a	±1.95 (±0.39) ^a
	μm	±0.5 (±0.1) ^a	±0.5 (±0.1) ^a	±0.5 (±0.1) ^a
Parallelism	in x 10 ⁻⁵	39	39	39
	μm	10	10	10
Max load	lb	45	45	225
	N	200	200	1,000
Max transportable moments				
Rolling moment	ft-lb	3.69	5.16	45.73
	N-m	5.0	7.0	62.0
Pitching moment	ft-lb	5.16	5.16	45.73
	N-m	7.0	7.0	62.0
Yaw moment	ft-lb	5.16	5.16	45.73
	N-m	7.0	7.0	62.0
Slider weight	lb	2.2	3.1	11.0
	kg	1.0	1.4	5.0
Rail weight	lb/in	0.73	0.84	1.40
	kg/m	13	15	25
Z-channel	pulse/in	1/0.0808	1/0.0808	1/0.0808
	pulse/mm	1/2.048	1/2.048	1/2.048
Stroke length	in	1.9-59	1.9-59	1.9-59
	mm	50-1,500	50-1,500	50-1,500
Life	km	[2,000/(200+W/4)] ^b x 50	[2,000/(200+W/4)] ^b x 50	[8,330/(500+W/4)] ^b x 50
		W: Load (N)	W: Load (N)	W: Load (N)

- Notes: ^a Shown the specification of ±0.1 (μm) version, which can be requested through Custom Products.
^b Shown here is the positional accuracy, the value at 22°C (coefficient of linear expansion 8 x 10⁻⁶/°C)
^c Shown for L₁ ≤ 700 mm (27.5 in), positional accuracy for L₁ ≥ 800 mm (31.5 in) = 50 + 50/1,000 * L₁ (μm)
 English units are provided for convenience.

Driver Specifications

	LM1050/LM5040	LM1100/LM5090	LM1300/LM5270
Input Signal			
Command Interface			
Position mode	Step input: Low going, low pulse, 150 nanoseconds minimum pulse width, 1.8 MHz max (LM1000) or 2.0 MHz max (LM5000) Direction input: Logic high = UP direction; Logic low = DOWN direction		
Velocity mode	Analog input: ±10 VDC command signal		
Force mode	Analog input: ±8 VDC command signal		
Output Signal			
Speed signal	+6V (UP direction); -6V (DOWN direction)		
Encoder signal	Track A/B (4,000 kHz max.), Z-channel signal: 1 pulse/2.048 mm (LM1000) or 1 pulse/4.096 mm (LM5000)		
Alarm signal	Over current, over voltage, over temperature of heat sink, Under voltage, encoder abnormal, CPU		

LM5000 Series Motor Specifications

		LM5040	LM5090	LM5270
Performance				
Maximum force	lb	9.0	20.2	60.7
	N	40	90	270
Positional accuracy ^b	in x 10 ⁻⁴	19.5 + (0.0195) * L _s ^c	19.5 + (0.0195) * L _s ^c	19.5 + (0.0195) * L _s ^c
	µm	50 + (50/1,000) * L _s ^a	50 + (50/1,000) * L _s ^a	50 + (50/1,000) * L _s ^a
Maximum speed	in/s	78	78	78
	m/s	2.0	2.0	2.0
Encoder resolution	in x 10 ⁻⁸ /pulse	3.9	3.9	3.9
	µm/pulse	1.0	1.0	1.0
Repeatability	in x 10 ⁻⁸	±3.9	±3.9	±3.9
	µm	±1	±1	±1
Parallelism	in x 10 ⁻⁶	39	39	39
	µm	10	10	10
Max load	lb	45	45	225
	N	200	200	1,000
Max transportable moments				
Rolling moment	ft-lb	3.69	5.16	45.73
	N-m	5.0	7.0	62.0
Pitching moment	ft-lb	5.16	5.16	45.73
	N-m	7.0	7.0	62.0
Yaw moment	ft-lb	5.16	5.16	45.73
	N-m	7.0	7.0	62.0
Slider weight	lb	2.2	3.1	11.0
	kg	1.0	1.4	5.0
Rail weight	lb/in	0.73	0.84	1.40
	kg/m	13	15	25
Z-channel	pulse/in	1/0.161	1/0.161	1/0.161
	pulse/mm	1/4.096	1/4.096	1/4.096
Stroke length	in	1.9-59	1.9-59	1.9-59
	mm	50-1,500	50-1,500	50-1,500
Life	km	$[2,000/(200+W/4)]^3 \times 50$	$[2,000/(200+W/4)]^3 \times 50$	$[8,330/(600+W/4)]^3 \times 50$
		W: Load (N)	W: Load (N)	W: Load (N)

Notes: ^a L_s = stroke length in mm
^b Shown the value at 22°C (Coefficient of linear expansion 8 x 10⁻⁶/°C)
^c L_s = stroke length in inches
 English units are provided for convenience.

Linear Series Standard Product Configuration

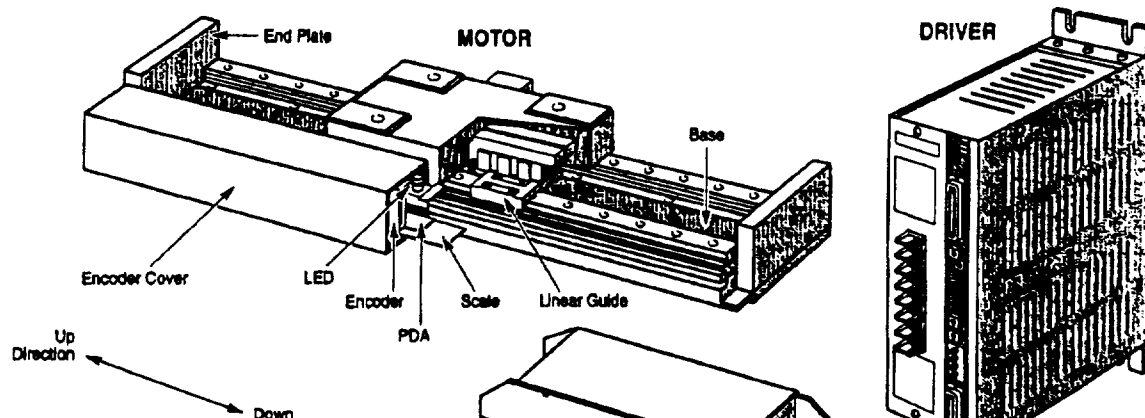

8.2 Linear Serv Speed/Force Curves

The speed/force curves represent peak force available; continuous forces are approximately 2/3 of the peak force value.

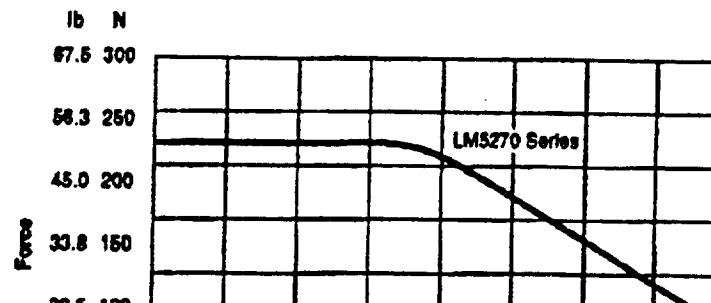
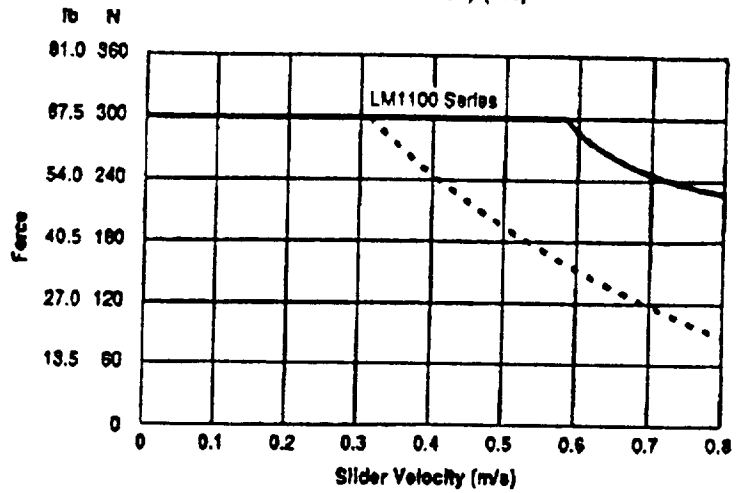
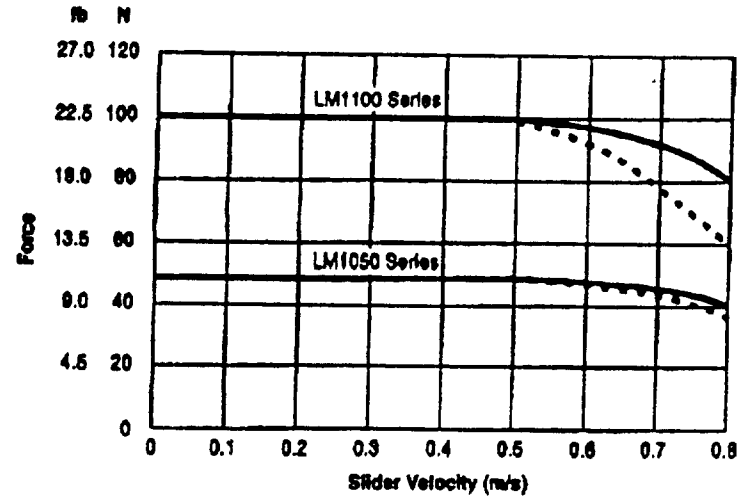

8.3 External Dimensions

LM1050/LM5040 Motor Dimensions (—) denotes millimeters

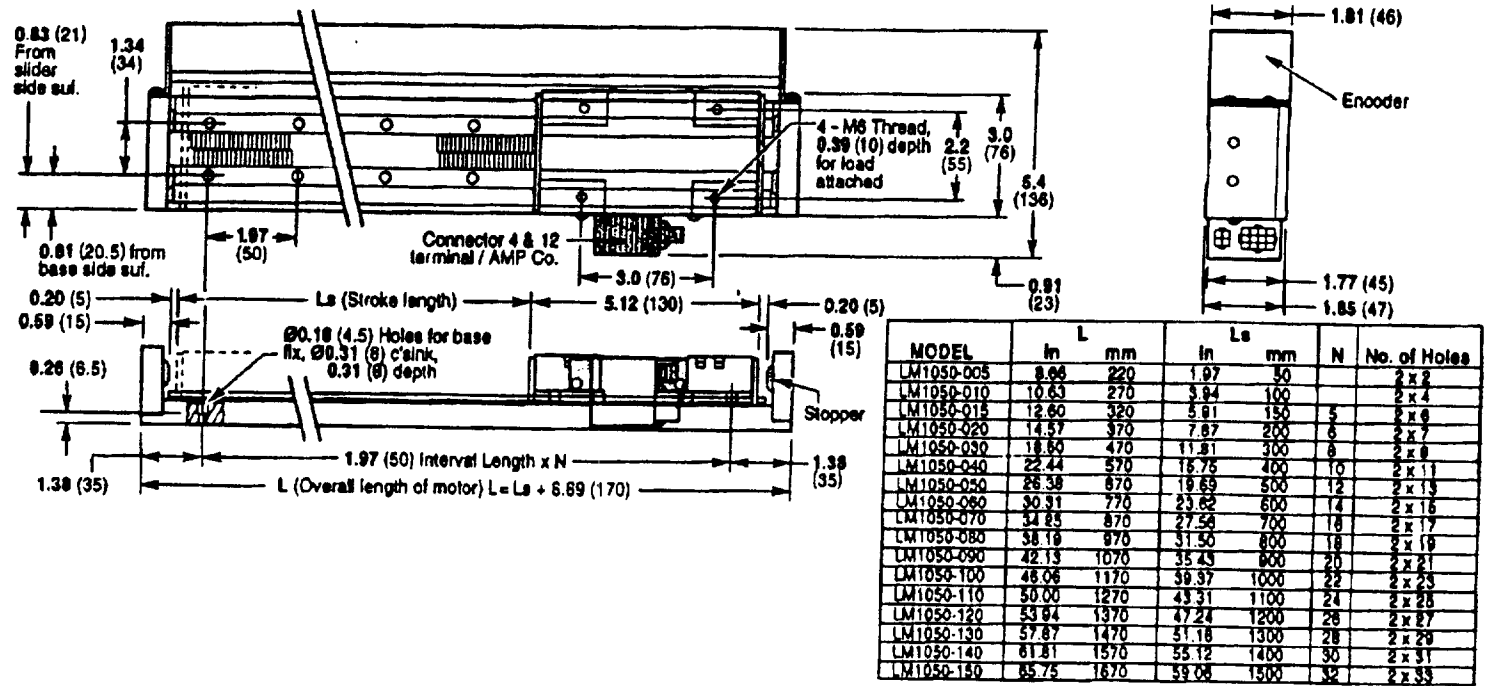

LM1100/LM5090 Motor Dimensions (—) denotes millimeters

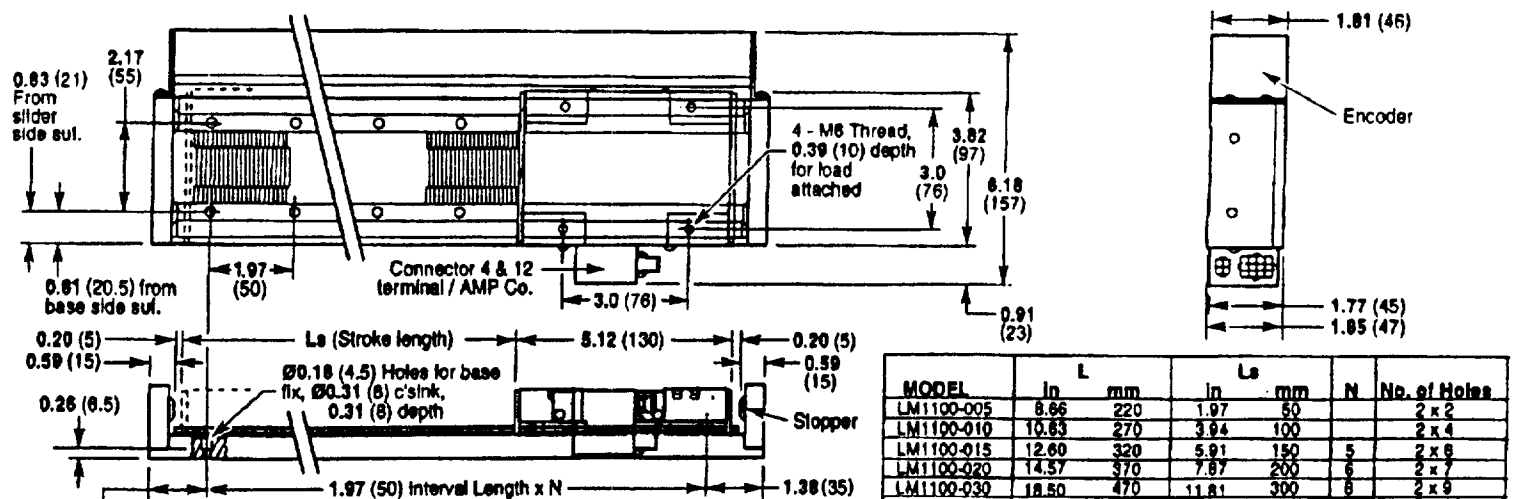

LM1300/LM5270 Motor Dimensions (—) denotes millimeters

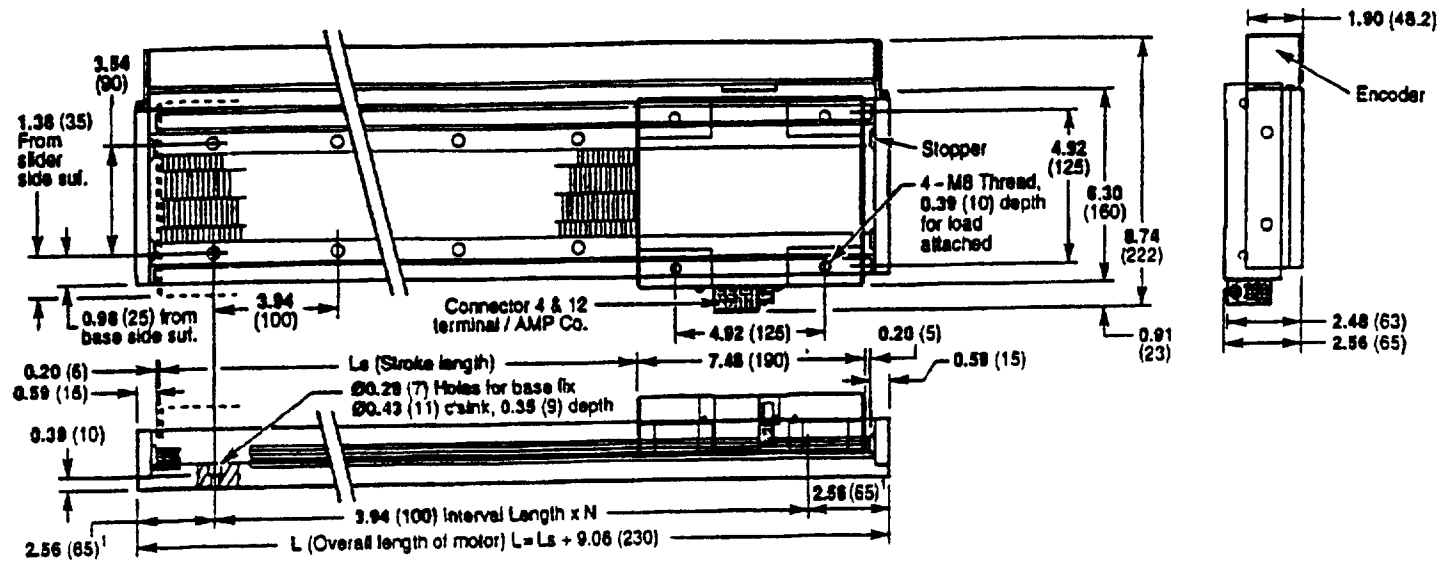

Note:¹ Dimensions for LM1300-005 and LM1300-015 are 1.57 (40) instead of 2.56 (65).

English units are provided for convenience.

MODEL	L		L _s		N	No. of Holes
	in	mm	in	mm		
LM1300-005	11.02	280	1.97	50		2 x 2
LM1300-010	12.99	330	3.94	100		2 x 2
LM1300-015	14.96	380	5.91	150	3	2 x 4
LM1300-020	16.93	430	7.87	200	3	2 x 4
LM1300-030	20.87	530	11.81	300	4	2 x 6
LM1300-040	24.80	630	15.75	400	5	2 x 6
LM1300-050	28.74	730	19.69	500	6	2 x 7
LM1300-060	32.68	830	23.62	600	7	2 x 8
LM1300-070	36.61	930	27.56	700	8	2 x 9
LM1300-080	40.55	1030	31.50	800	9	2 x 10
LM1300-090	44.49	1130	35.43	900	10	2 x 11
LM1300-100	48.43	1230	39.37	1000	11	2 x 12
LM1300-110	52.36	1330	43.31	1100	12	2 x 13
LM1300-120	56.30	1430	47.24	1200	13	2 x 14
LM1300-130	60.24	1530	51.18	1300	14	2 x 15
LM1300-140	64.17	1630	55.12	1400	15	2 x 16
LM1300-150	68.11	1730	59.06	1500	16	2 x 17

Drive Dimensions
 (—) denotes millimeters

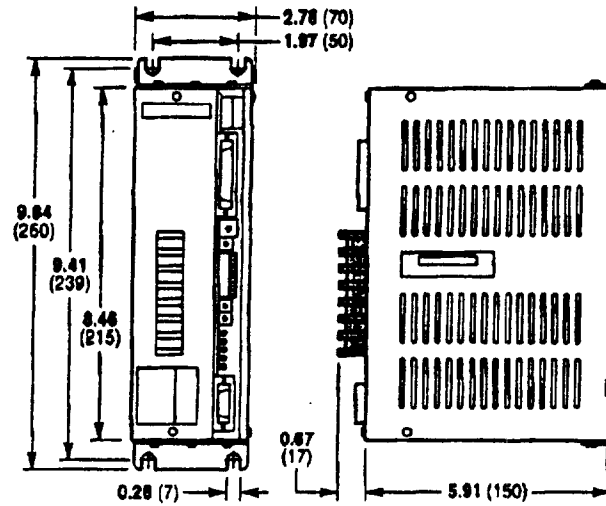

Head Amplifier

(—) denotes millimeters

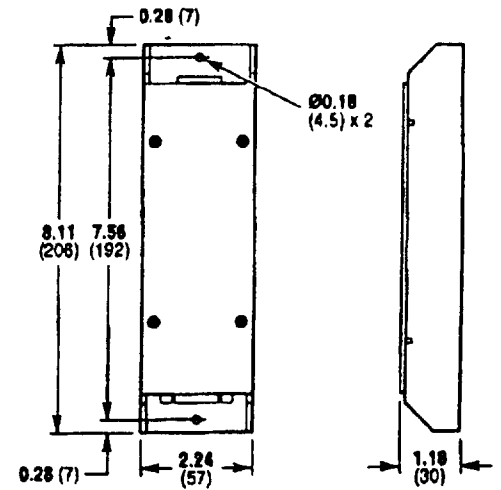

Cable Option #1

- ① 3 m (10 ft) Motor Cable

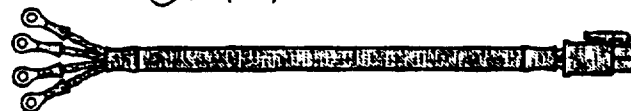

- ② 1.5 m (5 ft) Head-Amp Cable



8.4 Driver Block Diagram

