

# C H A P T E R ①

---

## *Introduction*

### **OEM670T/OEM675T DESCRIPTION**

The OEM670T/OEM675T is a torque servo drive designed to operate standard 3 phase brushless DC servo motors equipped with Hall effect sensors, or equivalent feedback signals. It can also operate brushed DC servo motors. It is a high-performance module around which the Original Equipment Manufacturer (OEM) can design a motion control system. The drive offers a basic set of features designed to meet the needs of most customers. It is compatible with standard industry servo controllers, and is intended to be used in positioning applications. It uses three-state current control for efficient drive performance and cooler motor operation.

The OEM670T/OEM675T is small and convenient to use. It installs with only two screws (the screws also provide grounding and captivate the cover). Its rightangle screw terminal allows side-by-side mounting, and its small footprint maximizes cabinet space. The snap-on molded cover is removable for drive configuration, and helps provide a barrier against environmental contamination. The drive is the same size as a 3U Eurorack card. Its standard 25 pin D-connector is compatible with universally available connectors.

The drive is designed for manufacturability and reliability. It uses surface mount components and a custom designed ASIC to conserve space, reduce cost, and improve reliability. More than 90% of the components are auto inserted, which reduces assembly time and cost, and further improves reliability.

### **OEM670T/OEM675T OPERATION & BLOCK DIAGRAM**

The OEM670T/OEM675T Torque Drive requires a single external power supply. The drive accepts 24VDC to 75VDC for

① Introduction • OEM670/OEM675

its power input. Its internal DC-to-DC converter produces +5V to power Hall effect sensors, ±15V to power isolated outputs, and all internal voltages used for the drive's circuits.

The drive operates in *torque mode*, which means it provides a commanded amount of current to a motor. This current causes torque in the motor.

The drive's block diagram is shown in the next drawing.

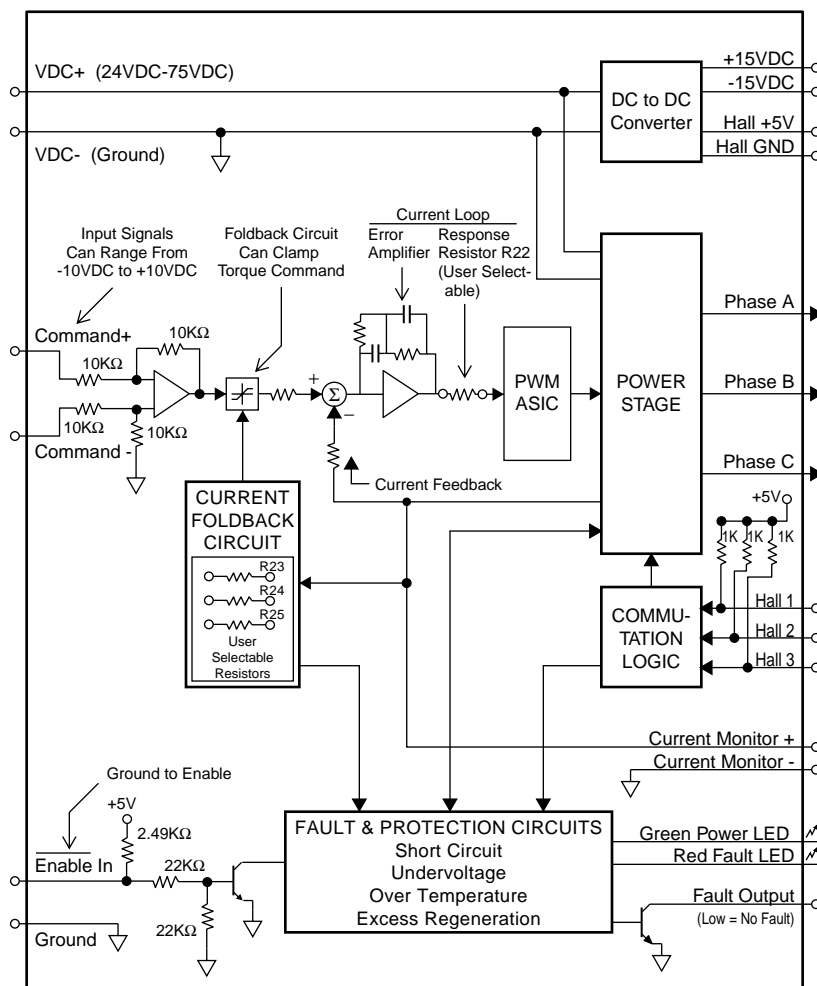

Block Diagram — OEM670T & OEM675T Torque Servo Drive

Input to the drive is a voltage signal called *command input*. It can range from -10VDC to +10VDC. Output current is scaled so that each volt of command input corresponds to 1.2A of output current. For example, a command input of 5V results in a 6A output current. The maximum command input of 10V results in the full 12A output current.

The command input terminals can accommodate single ended, differential, or isolated controller wiring systems. When the command input signal enters the drive, it is amplified, sent through a foldback circuit (which may or may not be active) and an inverter, and summed with a current feedback signal that is proportional to the actual output current.

An error signal—the difference between commanded and actual output current—goes through an error amplifier. The amplifier's output controls a pulse width modulation (PWM) circuit. If actual current is too low, the PWM circuit will send longer pulses to the power stage. These pulses keep the stage turned on longer, which results in more output current. If actual current is too high, the PWM circuit sends shorter pulses, resulting in less current.

A *response resistor* affects the signal level that goes into the PWM circuit. The user can choose a value for this resistor that produces the best current loop gain and system dynamics for a particular motor.

The power stage has three outputs—each connects to a particular motor coil. The drive gets inputs from the motor's Hall effect sensors, and determines which of six possible positions the rotor is in. It then uses a six-state commutation technique to send current into one coil and out of another (the third coil receives no current). The current creates a torque on the rotor, and the rotor turns to the next position. The drive reads the new position from the Hall sensors, and switches current to a different combination of coils. The rotor turns further, and the process repeats. (The drive can also be configured to commutate brushed servo motors.)

The drive has several fault and protection circuits. These monitor temperature, regeneration, undervoltage, and short circuits. They can shut down the drive if limits are exceeded. LEDs indicate power and fault status.

① *Introduction • OEM670/OEM675*

A foldback circuit monitors motor current, and protects the motor from overheating due to prolonged high currents. The user can install resistors to set levels for peak current, foldback current, and time constant. When the circuit invokes foldback, it clamps the command input signal at a voltage that reduces motor current to the preset level. After a period of time, the circuit may release its clamp on the command input signal, and normal operations can continue.

The drive has several other inputs and outputs. An enable input must be grounded to enable the drive. A fault output is held low if there are no faults. A current monitor output provides a voltage scaled to represent the actual output current. It can range from -10V to +10V, with one volt corresponding to 1.2 amps of output current.

## RELATED PRODUCTS

---

The OEM670T/OEM675T is the “building block” in a family of servo drives. It has an internal slot where an additional circuit board can be inserted to make a different product.

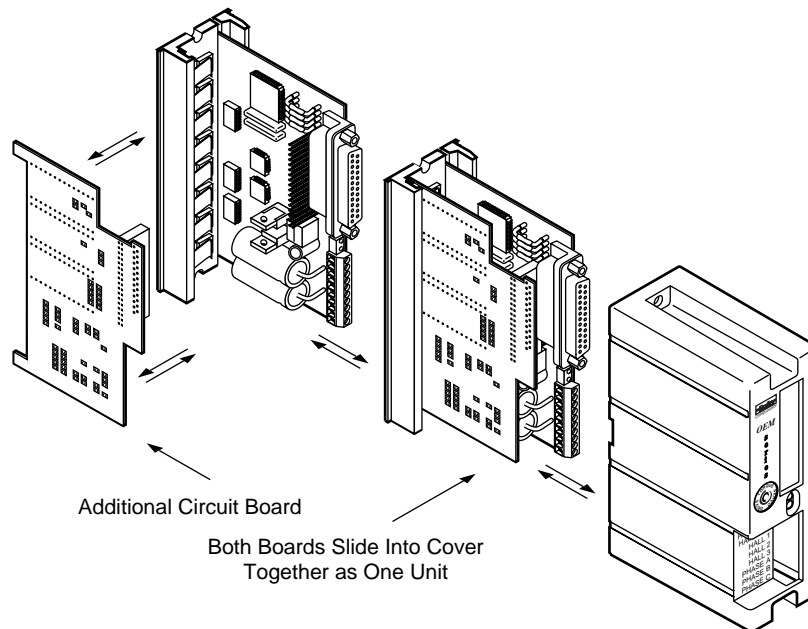

*Additional Circuit Board Can Mount Internally*

The additional circuit board is inserted at the factory, at the time of manufacture. Externally, the new product looks just like the OEM670T/OEM675T, except that the label is a different color.

**OEM670SD & OEM675SD STEP & DIRECTION SERVO DRIVE**

The OEM670SD/OEM675SD Step & Direction Servo Drive consists of the OEM670T/OEM675T with a position controller circuit board added.

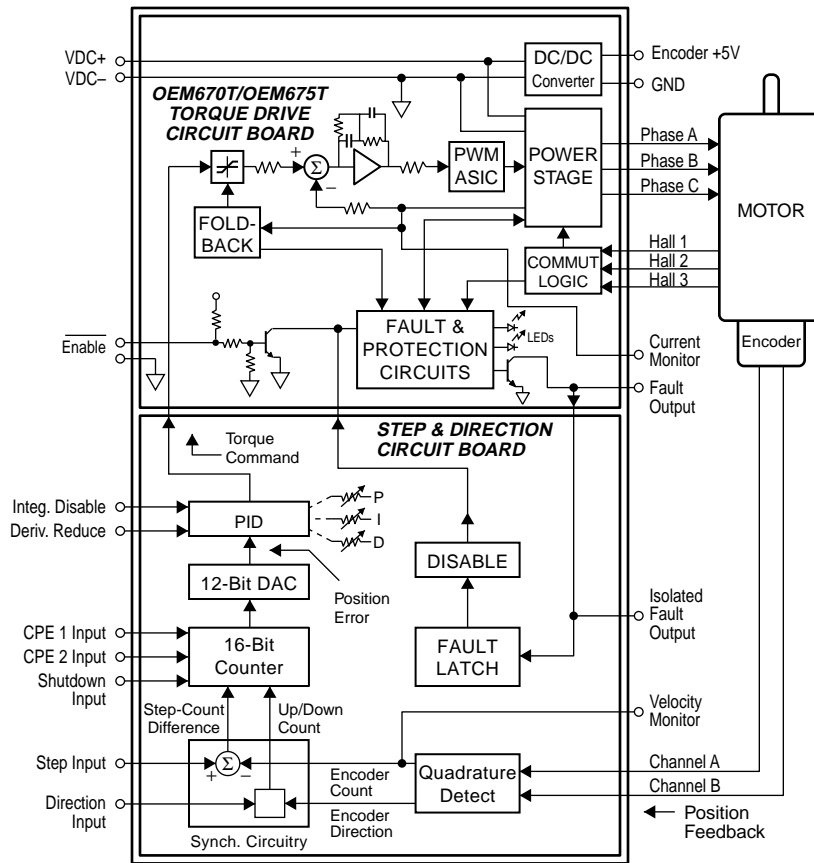

Block Diagram – OEM670SD/OEM675SD Step & Direction Servo Drive

The controller accepts step and direction position commands from an indexer. It uses encoder signals for feedback. Its

① Introduction • OEM670/OEM675

internal PID position control loop generates an analog command output voltage that is sent to the torque board.

Indexers intended for use with step motor systems can operate the OEM670SD. It emulates a stepper drive, but can achieve servo system levels of high speed performance and thermal efficiency.

**OEM670X & OEM675X POSITION CONTROLLER/DRIVE**

The OEM670X/OEM675X Controller/Drive consists of the OEM670T/OEM675T with a position controller circuit board.

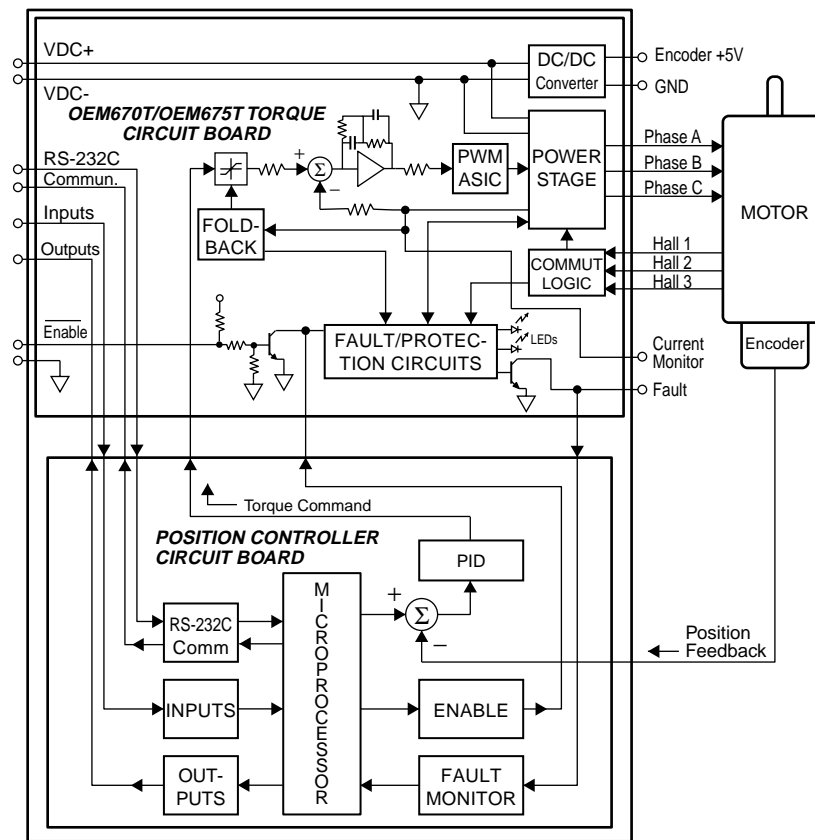

OEM670X/OEM675X Position Controller/Drive — Block Diagram

Inputs, outputs, and RS-232C communications are internally routed to the position controller board, where they interface

with a microprocessor. The microprocessor generates a position command. It can also enable or disable the torque board.

The position controller board receives feedback about actual position from an encoder, and compares commanded position with actual position. It generates a torque command to correct any position errors. The torque command (which is an analog voltage) then goes to the torque board, passes through the foldback circuit, and proceeds through the remainder of the torque board's circuits.

### OEM070 SERVO CONTROLLER

The OEM070 Servo Controller is a compact, stand-alone controller designed to operate with analog servo drives.

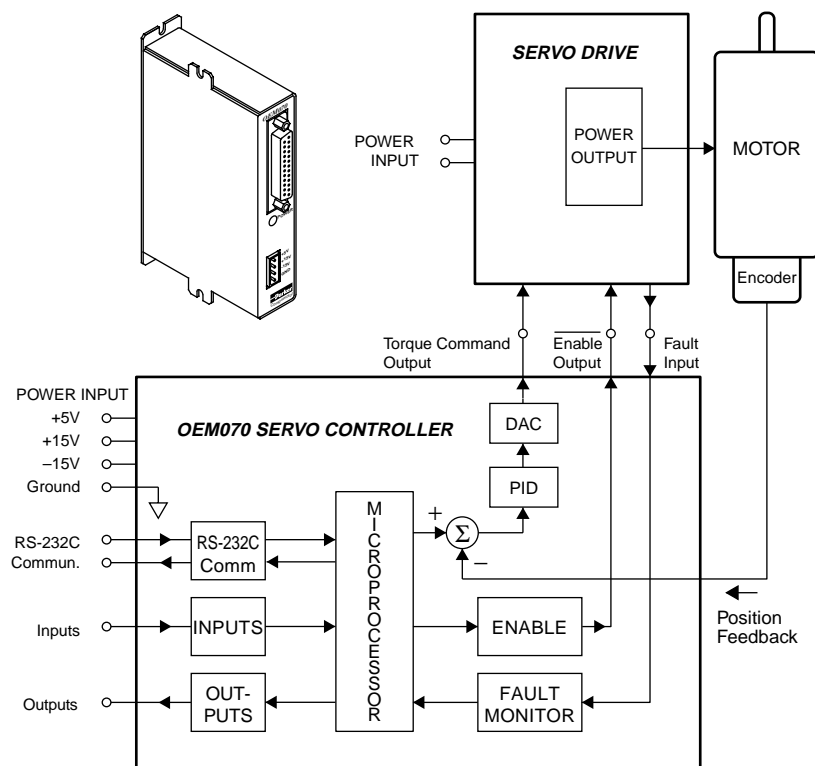

OEM070 Servo Controller – Block Diagram

### ① Introduction • OEM670/OEM675

The OEM070 contains the same position controller board used in the OEM670X/OEM675X. The board is packaged by itself in a minimum depth, small footprint housing. It controls motor torque or velocity with a  $\pm 10V$  command output signal. Through its I/O and RS-232C ports, the OEM070 can interface with external devices such as incremental encoders, switches, computers, and programmable control units.

## **SM AND NEOMETRIC SERIES SERVO MOTORS**

---

Compumotor offers SM Series and NeoMetric Series servo motors designed to operate with OEM Series servo drives. Each motor is equipped with Hall effect outputs and an encoder.

### **OEM670 versus OEM675: How to Choose?**

---

You can decide whether to use an OEM670 or OEM675 based upon the motor you choose for your application.

**Compumotor SM Series Motor:** choose an OEM675. Its current compensation loop is optimized for SM (slotless) motors.

**Compumotor NeoMetric Series Motor:** choose an OEM670. Its current compensation loop is optimized for NeoMetric (slotted) motors.

**Non-Compumotor Motor:** If yours is a non-Compumotor motor, examine the motor specification tables for Compumotor motors in *Chapter ③ Specifications*, and find a motor with inductance and resistance similar to yours. If the similar motor is an SM Series motor, choose an OEM675. If the similar motor is a NeoMetric Series motor, choose an OEM670.

If you cannot find a similar motor in the specification tables, you may need to contact a Compumotor Applications Engineer (800-358-9070) for advice on choosing a drive for use with your motor.