

# C H A P T E R ④

---

## *Special Internal Circuits*

The OEM670/OEM675 has several internal circuits that can protect the drive, protect equipment connected to the drive, or change the drive's performance characteristics.

Four of the built-in circuits work automatically. Their performance cannot be changed or altered.

- Short Circuit Protection
- Undervoltage
- Overvoltage
- Overtemperature

Two of the circuits use removable resistors in sockets. You can change these resistors to alter the circuit parameters.

- Response Circuit
- Current Foldback Circuit

This chapter explains the performance of these circuits.

### **SHORT CIRCUIT PROTECTION**

---

The OEM670/OEM675 continuously monitors the current it sends to the motor. If it detects excessive current, it interprets the excessive current as a short circuit fault in the motor or cabling. The OEM670/OEM675 disables its power output to the motor terminals—Phase A, Phase B, and Phase C.

To show that a short circuit fault has occurred, the drive illuminates the red LED, turns off the green LED, and causes the fault output (pin 9) to go high. Other power outputs—Hall +5, +15VDC, -15VDC—remain on.

④ **Special Internal Circuits • OEM670/OEM675**

The short circuit fault is a *latched* condition. Latched means that the output will remain off until power is cycled. To *cycle power*, turn off the power to the drive, wait approximately 30 seconds, then turn on the power.

The other power outputs (Hall +5, +15VDC, -15VDC) are not short circuit protected.

Short circuit protection features are summarized below.

- Power to motor is turned OFF
- Red LED is turned ON (Illuminated)
- Green LED is turned OFF (Not Illuminated)
- Fault output goes HIGH
- Latched
- Hall +5, +15VDC, -15VDC remain powered
- Hall +5, +15VDC, -15VDC are not short circuit protected

*(Troubleshooting Note: Other faults will also turn on the red LED, but they leave the green LED illuminated. Short circuit protection is the only fault that will turn off the green LED when it turns on the red LED.)*

A short circuit fault is not the only event that can trigger this circuit. A power supply fault can also trigger short circuit protection. The fault can occur if the supply is undersized, and cannot provide enough power during demanding move profiles.

The next drawing shows graphs for motor current and power supply voltage during a normal move profile.

OEM670/OEM675 • ④ *Special Internal Circuits*

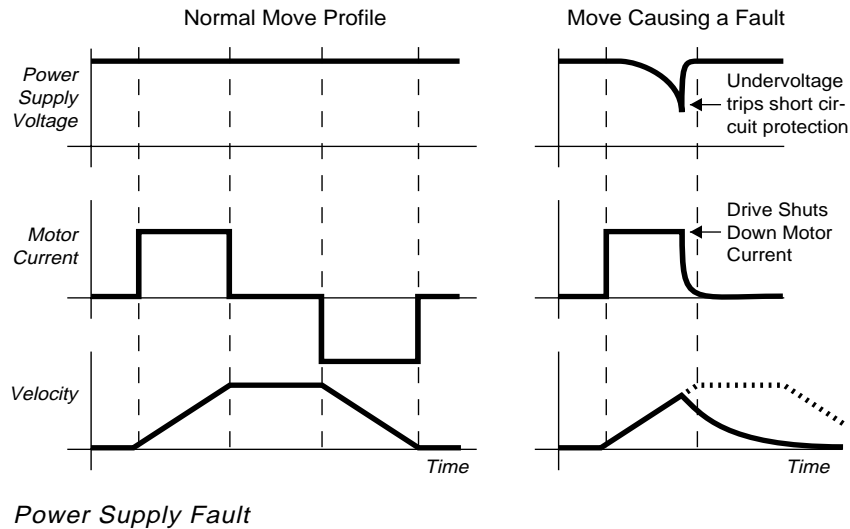

The drawing also shows what happens to voltage if the power supply is inadequate. During the first part of the move, energy stored in the power supply (in the capacitors, for example) can provide power for the move. As this energy is used up, the power supply cannot replenish it fast enough, and the voltage drops. If the voltage gets too low, short circuit protection is turned on, and shuts down motor current. At this point the power supply no longer needs to provide power to the drive. It can now direct power into its own capacitors. They recharge, and the supply voltage quickly returns to normal levels.

This is a transient event. Without short circuit protection, it may go undetected. Your system's performance could be less than you expected, and you might not know why. Short circuit protection latches the drive off during the transient event, however. This allows you to realize there is a problem, and find the cause. Once you determine there is no short circuit in your motor or cabling, you can inspect your power supply.

If your system runs while the motor is stopped or turning slowly, but faults during demanding move cycles, then your power supply may be causing the fault because it is inadequate for the task. Consider using a larger power supply, or altering your move profile so that the move requires less power.

#### ④ *Special Internal Circuits • OEM670/OEM675*

The same condition—a momentary power supply fault—can sometimes turn on the undervoltage circuit, rather than short circuit protection. The undervoltage circuit is explained in the next section.

There are two potential warning signals, then, to alert you about power supply problems. Short circuit protection will latch, and shut down the drive. Undervoltage protection will momentarily turn on the red LED (but not turn off the green LED), and will not latch.

## **UNDervOLTAGE**

---

The undervoltage circuit monitors power supply voltage. If the voltage falls below a threshold level—21.5VDC or less—the undervoltage circuit will illuminate the red LED, and cause the fault output (pin 9) to go high. The green LED remains illuminated.

For the OEM670T/OEM675T, this condition *is not latched*. If the power supply voltage rises above the threshold, the red LED turns off, and the fault output goes low.

For the OEM670SD/OEM675SD, this condition *is latched*.

Undervoltage circuit features are summarized below.

- 21.5VDC threshold (Maximum)
- Red LED is turned ON (Illuminated)
- Green LED stays ON (Illuminated)
- Fault output goes HIGH
- Not Latched - OEM670T/OEM675T  
Latched - OEM670SD/OEM675SD

The undervoltage circuit ensures an orderly startup and shutdown process. During startup, when the power supply's voltage is rising, the undervoltage circuit will not allow the drive to turn on until the voltage rises above the threshold, and there is enough power to maintain the drive's circuits. During shutdown, when the power supply voltage falls below the threshold, the circuit will turn off the drive's circuits in an

orderly and systematic manner. You may see the red LED come on briefly when the drive is turned on or off. This is normal, and does not indicate a problem.

One problem situation—a power supply undervoltage fault—can trigger the undervoltage circuit. (See the power supply fault explanation above, under *Short Circuit Protection*.) An undervoltage fault can trigger either the undervoltage circuit or short circuit protection. Sometimes the undervoltage circuit will react first, and turn on the red LED and send the fault output high. At other times, short circuit protection will react first, and latch the drive off. Which circuit reacts first depends on the dynamics of the fault, and is not easily predictable.

The undervoltage circuit can help you diagnose power supply problems.

*OEM670T/OEM675T Example:* You use a 24VDC power supply to power an OEM670T/OEM675T. During certain parts of the move, your system's performance is less than you expect, and you notice that the red LED flashes. The flashing LED indicates that either the drive is in current foldback, or that the power supply's voltage is too low. If you monitor the fault output and notice that Pin #9 goes high when the LED flashes, you can rule out foldback. Foldback does not make the fault output go high. The problem is a power supply undervoltage fault. Try a larger power supply, or a less demanding move profile.

## **OVERVOLTAGE**

---

The overvoltage circuit protects the drive from regeneration. The OEM670/OEM675 monitors voltage at its motor output terminals—Phase A, Phase B, and Phase C. If the motor regenerates energy, and the voltage rises above a threshold level—95VDC  $\pm$  5VDC—the circuit will disable power output to the motor. This is a latched condition. You must cycle power to restart the drive.

The circuit also turns on the red LED, and activates the fault output. Other power outputs—Hall +5, +15VDC, -15VDC—remain on. The green LED also stays on.

#### ④ *Special Internal Circuits • OEM670/OEM675*

Overvoltage circuit features are listed below.

- 95VDC  $\pm$  5VDC threshold
- Power to motor is turned OFF
- Red LED is turned ON (Illuminated)
- Green LED stays ON (Illuminated)
- Fault output goes HIGH
- Latched
- Motor freewheels to a stop
- Does not protect against power supply overvoltage

After an overvoltage fault, the drive does nothing to stop the motor. When it stops receiving current, the motor will freewheel to a stop. If you have components that could be damaged by a freewheeling motor, consider using an external brake.

For example, in a system that raises and lowers a load, regeneration may occur while the load is being lowered. If the regeneration exceeds the 90VDC threshold and the overvoltage circuit shuts down motor current, the motor might freewheel, and the load could plunge to the floor. To avoid damage, a brake could be employed to stop the load in the event of a sudden loss of motor torque.

---

---

#### **CAUTION**

The overvoltage protection circuit can shut down current to the motor. This can cause a sudden and unexpected loss of motor torque. The motor will freewheel to a stop. Consider using a brake to arrest motion if your system regenerates energy.

---

---

Another possible concern is power supply overvoltage. The overvoltage circuit only monitors voltage at the output terminals to the motor. It does not monitor power supply voltage. This means that the drive is not protected from a defective power supply that produces excessive voltage. To protect the drive in this situation, use a power supply with built-in overvoltage protection on its outputs, such as Compumotor's OEM300 Power Module.

---

## **OVERTEMPERATURE**

The overtemperature circuit protects the OEM670/OEM675 from damage due to overtemperature conditions. This circuit

#### OEM670/OEM675 • ④ *Special Internal Circuits*

monitors the temperature of the drive's heatplate. A temperature rise above 50°C (122°F) will cause an overtemperature fault. The protection circuit will disable power output to the motor, turn on the red LED, and activate the fault output. This is a latched condition. Other power outputs—Hall +5, +15VDC, -15VDC—remain on.

Overtemperature circuit features are listed below.

- 55°C ± 5°C (131°F ± 9°F) threshold
- Power to motor is turned OFF
- Red LED is turned ON (Illuminated)
- Green LED stays ON (Illuminated)
- Fault output goes HIGH
- Latched
- Cool below 40°C (104°F) and cycle power to restart

The overtemperature protection circuit has built-in thermal hysteresis. This means that the OEM670/OEM675 cannot operate again until it has had time to cool below approximately 40°C (104°F). Once it has cooled, you must cycle power to restart the drive.

#### ***Design Tip***

Use 50°C (122°F) as the maximum heatplate temperature allowed for continuous operation of the drive. Because of manufacturing tolerances on circuit components, different OEM670/OEM675 units will shut down at different temperatures in the 50°C to 60°C range (122°F to 140°F). For predictability, use 50°C (122°F) as the shutdown temperature.

#### ***Troubleshooting Note***

An overtemperature fault is a sign that something is wrong with your installation. Typical causes of overtemperature faults are:

- Inadequate Ventilation (broken fan, blocked vent, etc.)
- Inadequate Heatsink (too small, missing, not cooled properly, etc.)
- Assembly mistakes (mounting screw not tight, poor thermal contact, etc.)

If your drive has an overtemperature fault, do not simply cool the drive, cycle power, and resume operations. Instead, find the problem that caused the fault, and fix the problem.

## **Response Circuit**

---

All servo motors are not the same! The inductance of different motors covers a wide range. When you select a motor for use with the OEM670/OEM675, its inductance affects the gain and frequency response of the current feedback loop, and thus the performance of your system.

To accommodate the wide range of motors that customers are likely to use, the drive has a response circuit that is adjustable. You can tailor the response circuit to match your motor. This can help you achieve optimum performance.

You can adjust the response circuit by changing the response resistor, R22, on the drive's circuit board.

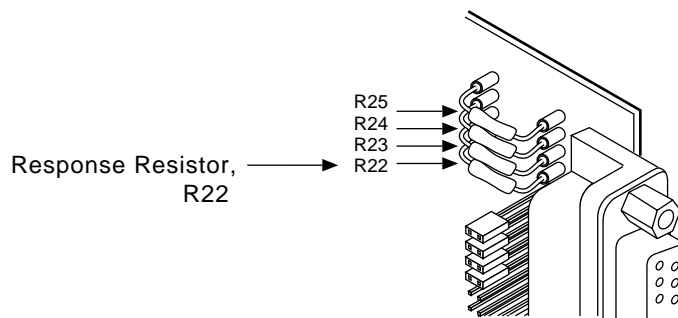

*Response Resistor Location*

See *Installing Selectable Resistors* in *Chapter 2 Installation* for instructions about installing a different response resistor, and for a list of resistors to use with Compumotor motors.

In the following sections, we will explain how the current feedback loop works, how motor inductance affects the loop, and how the response resistor can adjust drive performance to compensate for different motor inductances. Then, we will give detailed instructions for selecting a response resistor.

### **CURRENT FEEDBACK LOOP**

---

The following section of the OEM670/OEM675's block diagram shows the main components in the *current feedback loop*. This diagram shows the drive in one particular Hall state, with current flowing into phase A and out of phase C. Five other Hall states are possible. Their diagrams are similar.



OEM670/OEM675 • ④ Special Internal Circuits

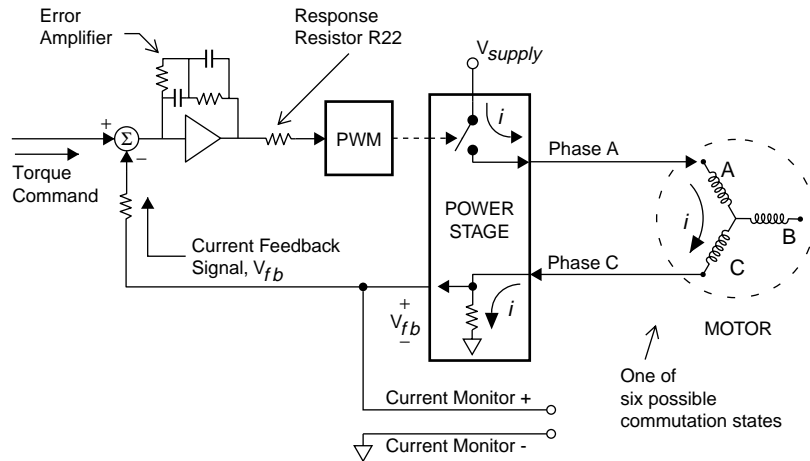

*Current Feedback Loop*

The torque command is a signal that tells the drive how much current to produce. This desired current is called *commanded current*. It enters the loop through a summing node, where it is combined with a current feedback signal.

The feedback signal is a voltage that represents *actual current* flowing in the motor. The signal's polarity is adjusted so that it is inverted at the summing node. (Inverters and other components that accomplish this are not shown in the diagram.) This makes it a negative feedback signal. If actual current is identical to commanded current, the sum of the two signals will be zero.

If the two currents are not identical, the summing node will produce an *error signal*, which enters an *error amplifier*. This amplifier has very high gain at low frequencies, and will amplify even very small signals by a factor of thousands.

The amplified error signal next passes through the *response resistor*, which can change the level of the error signal, and thus modify the gain of the error amplifier. Higher resistor values will reduce the signal; lower values will increase it. (More information about selecting a response resistor will be given at the end of this section.)

The error signal enters a *pulse width modulation (PWM)* circuit that controls the power stage. The drawing shows a simplified

#### ④ *Special Internal Circuits • OEM670/OEM675*

conceptual representation of how this control is accomplished. Voltage from a PWM pulse causes a switch to close. Current can then flow from an external power supply, through two coils of the motor, a sense resistor, and to ground. When the PWM pulse stops, the voltage controlled switch opens, which disconnects the power supply from the motor.

Together, the error amplifier, PWM circuit, and power stage form a voltage-to-current converter. A voltage that represents commanded current is converted to an actual current flowing in the motor. Longer PWM pulses will cause more current to flow; shorter pulses will cause less current to flow.

Notice that the motor current goes through a *sense resistor* before it reaches ground. The sense resistor is a current-to-voltage converter. Motor current flowing through it generates a voltage across the resistor. This voltage is proportional to actual current. It is used as the current feedback signal, *v<sub>fb</sub>*, which is fed back to the summing node. This signal is also accessible to the user at the current monitor output.

#### MOTOR INDUCTANCE AFFECTS FEEDBACK

So far, we have seen that there is motor inductance in the feedback loop, but we have not discussed its significance. To understand how inductance can affect a circuit, let us first look at a very simple circuit.

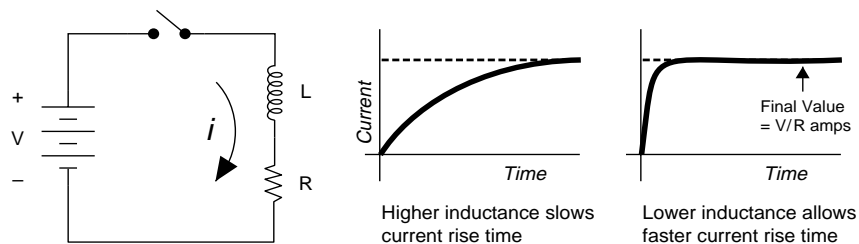

#### *Inductance Controls Rise Time*

This circuit consists of a battery, an inductor, a resistor, and a switch. When the switch is closed, current begins to flow in the circuit. The final value of the current depends on the voltage of the battery,  $V$ , and the size of the resistor,  $R$ . Its value is

OEM670/OEM675 • ④ *Special Internal Circuits*

$$I_{final} = V/R \text{ amps}$$

How long until the current reaches this final value? The rise time is determined by the size of the inductor. The inductor opposes the *change* in current flow. A large inductor will cause slow rise times. A small inductor will allow much faster rise times.

This circuit, although quite simple, is actually very similar to the OEM670/OEM675's current feedback loop, which is redrawn below.

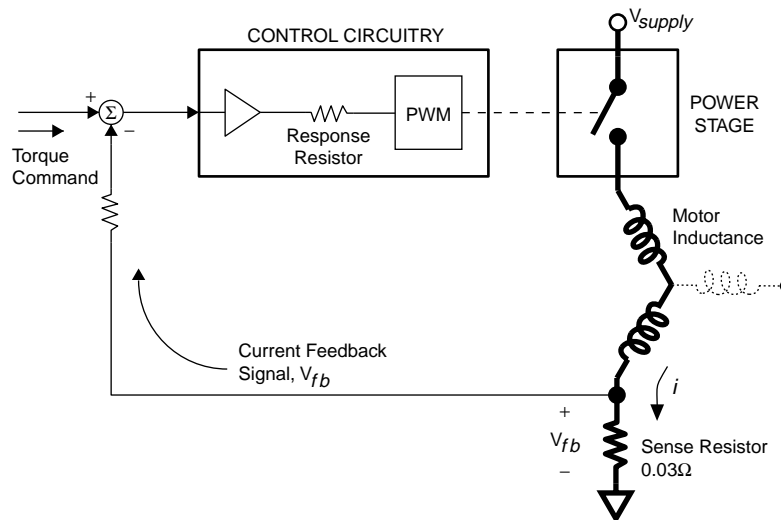

*Inductance in Feedback Loop*

Compare this circuit to the simple circuit with a battery, switch, inductor and resistor. In this circuit, the battery has been replaced with a power supply, the switch has been replaced by the power stage, the inductor has been replaced by the motor inductance, and the resistor has been replaced with a sense resistor (and motor and cabling resistance).

Most importantly, the switch is no longer controlled manually—it is now automatically controlled by a feedback loop. The most important control elements are shown together in the box labeled *Control Circuitry*.

In the feedback loop, commanded current is compared with actual current 20,000 times each second. After each compari-

#### ④ *Special Internal Circuits • OEM670/OEM675*

son, the control circuit increases or decreases current flow by changing the width of PWM pulses. Feedback about results of the change is not instantaneous, however, because time delays are built into each step of the feedback loop. Each PWM setting is maintained for 50 microseconds, until the next comparison is made. At that time, the control circuit compares the feedback signal to the command signal, adjusts PWM pulses—and the whole process repeats.

How does motor inductance affect feedback and the current control process? We will consider several situations in which the only variable that changes is motor inductance. In each of the following examples, assume that the power supply voltage and error amplifier gain do not change.

#### **Response with Low Inductance Motor**

The first drawing shows what can happen when the motor's inductance is low.

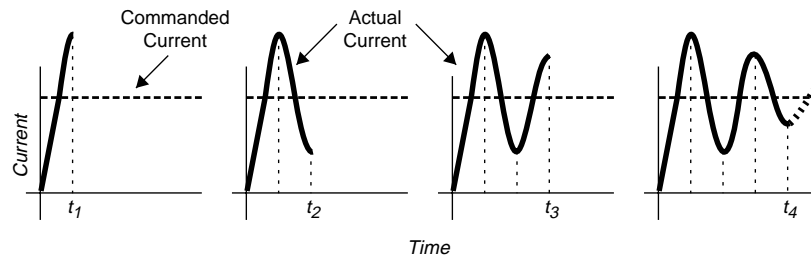

*Underdamped Response*

Recall that a low inductance permits a fast current rise. In this drawing, the system is given a commanded current. The drive compares actual current with commanded current, sees a large error, and directs the PWM circuit to produce maximum current. Motor inductance barely opposes current rise; because of the error amplifier's high gain, the current quickly rises to a level *higher* than commanded current.

At time  $t_1$ , the drive again compares actual with commanded current, and sees that actual current is too high. As a result, it *reduces* the power stage's current output. The change quickly results in an actual current that, at the next sample

time  $t_2$ , is too low. Current is *increased*, and by the next sample point, time  $t_3$ , it is once again too high. Adjustments continue in this manner, and eventually the amount of actual current settles near the commanded current level.

This type of response is called an *underdamped* response. For a given loop gain and power supply voltage, the main component influencing this response is the inductance of the motor. If the inductance is very low, the system can oscillate, with actual current never settling near commanded current. The next drawing shows this case.

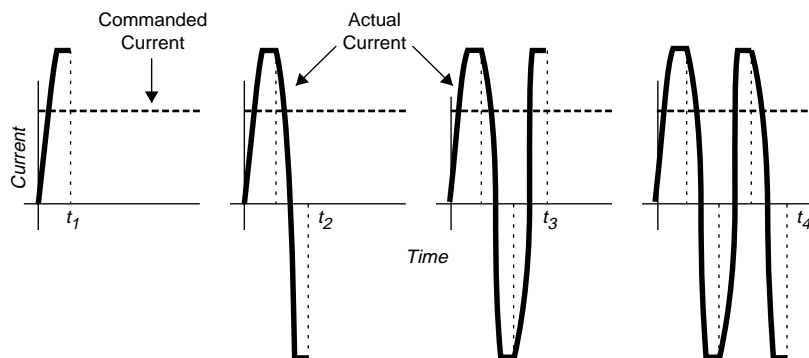

*Oscillating Response*

Here we see that current rise is so fast that the current output saturates at its maximum level before each successive sample. With 12A set as the maximum current, for example, actual current will oscillate between +12A and -12A. The motor will probably not turn—it can not respond as fast as the quickly changing currents—but it may become excessively hot due to the oscillating currents.

#### ***Response with High Inductance Motor***

Next, we consider the effects that a high inductance motor has on the feedback loop. The drawing below shows the *overdamped* response that is typical with high inductance.

④ **Special Internal Circuits • OEM670/OEM675**

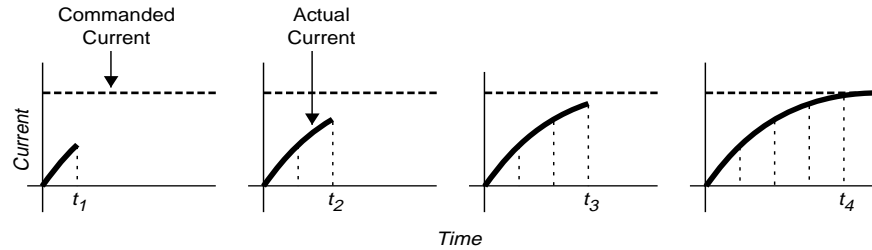

*Overdamped Response*

We see that actual current slowly rises to meet commanded current. The high inductance limits the current rise so much that by times  $t_1$ ,  $t_2$ , and  $t_3$ , actual current is still too low. In overdamped situations, we can achieve very good control, with no overshoot—but the response time is very slow.

**Optimum Response**

What type of response, then, is best? We want a fast current rise, so the system can quickly get to the commanded current level. But, the rise should not be so fast that the system repeatedly overshoots, and is underdamped. The next drawing shows an *optimum* response.

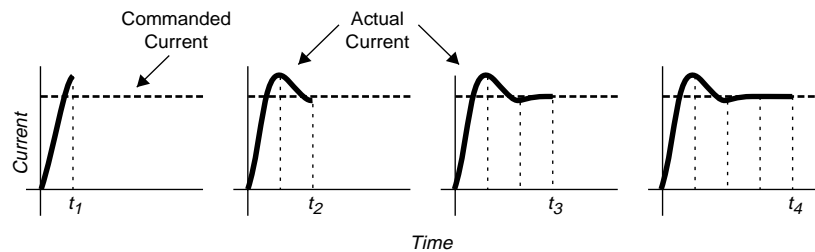

*Optimum Response*

In this example, the motor's inductance is well matched with the gain and timing of the current feedback loop. The inductance allows a fast current rise—but just fast enough so that, when the actual current level is rising past the commanded current level, it is time for the next sample. The control circuit compares commanded with actual current, and makes an adjustment. There is little overshoot, with a minimum settling time before actual current reaches commanded current.

If you change one component in this well-matched system—motor inductance, for example—you may need to adjust some other component to maintain the system's optimum response.

### **SELECTING A RESPONSE RESISTOR**

In the previous section, we discussed the effect different motors have on the drive's response. Once you have chosen a motor, the inductance in your system is fixed—it is no longer a variable. To adjust the response of your system for the motor you have chosen, you can install the correct response resistor.

If yours is a Compumotor motor, use the response resistor recommended for your motor in *Installing Selectable Resistors* in *Chapter ② Installation*. If yours is a non-Compumotor motor, examine the motor specification tables for Compumotor motors in *Chapter ③ Specifications*; find a motor with inductance and resistance similar to yours, and use the resistor recommended for that motor. In either case, you may have to make further adjustments as described below.

Once you have chosen a resistor, there are three possibilities for what to do next, based upon the response of your system.

- OPTIMUM RESPONSE – Use the resistor you have chosen.
- UNDERDAMPED RESPONSE – Use a higher value than the resistor you have chosen.
- OVERDAMPED – Use a lower value than the resistor you have chosen.

We will discuss each of these options below, and show a method for viewing response waveforms on an oscilloscope.

#### ***Optimum Response***

If your system has an optimum response with the resistor you have chosen, no further adjustments are necessary.

#### ***Underdamped Response***

To optimize if your system is underdamped, use a resistor

④ **Special Internal Circuits • OEM670/OEM675**

whose value is *larger*. The increased resistance will reduce the gain of the error amplifier, and diminish the signal that goes into the PWM circuit. Consequently, the power stage will be on for a shorter period of time, current rise will be slowed, and damping in your system will be increased.

**Overdamped Response**

To optimize if your system is overdamped, use a resistor whose value is *smaller*. With less resistance, the error amplifier's gain will be higher, a larger signal will reach the PWM circuit, and the power stage will stay on longer. More current will flow, which will cause a faster current rise. The system will have less damping, and will respond more quickly.

**A Graphical Representation**

The next drawing provides a visual summary of effects you can expect from changing either the motor inductance or the response resistor.

Arrows on the left side of the drawing show the effects of changing the motor inductance while keeping other components unchanged. Increasing the inductance will cause overdamping; decreasing the inductance will cause underdamping.

Arrows on the right side of the drawing show the effects of changing the response resistor while keeping other components unchanged. Increasing the resistance will make your system overdamped; decreasing the resistance will make it underdamped.



OEM670/OEM675 • ④ Special Internal Circuits

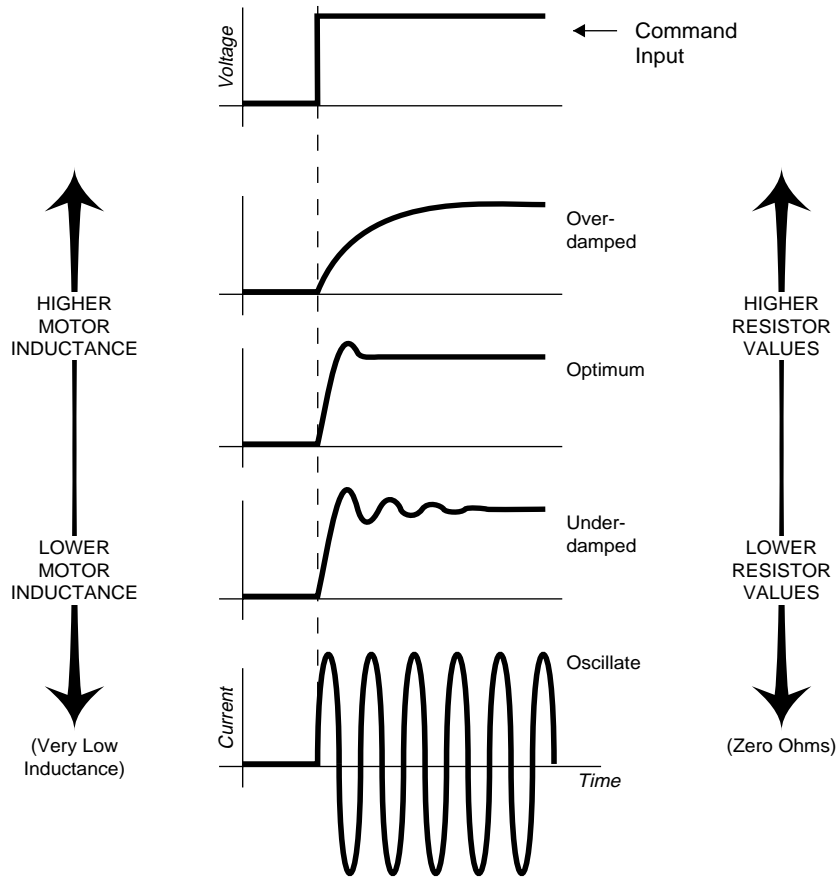

Response Waveforms

④ **Special Internal Circuits • OEM670/OEM675**

**Viewing the Response Waveform**

You can view your system's response waveforms on an oscilloscope, and compare them to the drawings we have presented throughout this section.

Connect an oscilloscope to the drive's current monitor output, as shown in the next drawing.

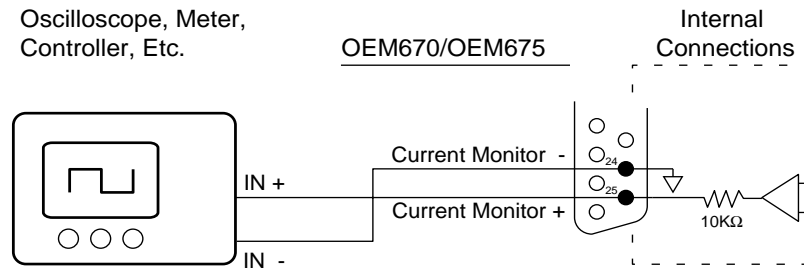

*Current Monitor Output Connections*

From the picture on your oscilloscope screen, you can see if your system is overdamped or underdamped. If necessary, change the value of the response resistor to improve performance. Monitor the waveforms until you get the response you want.

## **CURRENT FOLDBACK**

---

A mechanical jam in a servo system can cause the motor to overheat. In contrast to a stepper motor, which does not run hotter when jammed, a servo will apply full current (for full torque) while it attempts to move as commanded. Usually, this current will be *much* higher than the motor can withstand continuously. If it persists indefinitely, it may damage the motor's windings.

To help protect the motor from overheating, the OEM670/OEM675 has a *current foldback* circuit. If high motor current continues for too long, the circuit reduces the current to a lower level, which decreases the rate of motor heating.

You can adjust the foldback circuit by changing three resistors on the drive's circuit board—R23, R24, and R25.

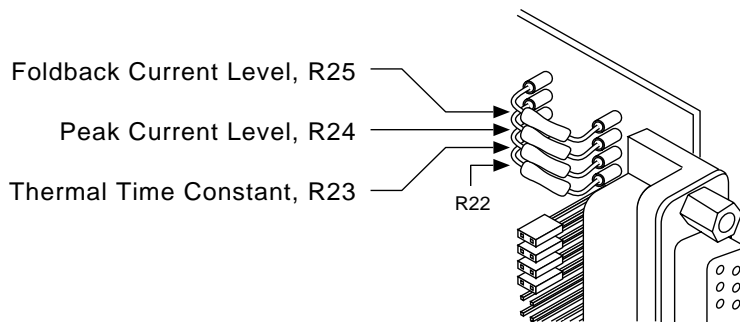

### *Foldback Resistor Locations*

See *Installing Selectable Resistors* in *Chapter ② Installation* for an explanation on how to change foldback resistors.

You have two options for choosing resistors for current foldback:

- Select resistors to use with Compumotor SM and NeoMetric Series motors.
- Select resistors to use with motors from other vendors.

The following sections will explain when you should use foldback, how the current foldback circuit works, and how to choose resistor values.

#### ④ *Special Internal Circuits • OEM670/OEM675*

##### **WHEN DO YOU NEED FOLDBACK?**

If you have properly sized the motor for your application, and you use a controller that can detect a mechanical jam, *you do not need foldback*. The controller can protect the motor more quickly and completely than a foldback circuit can. It can also keep the machine from producing bad parts, which sometimes happens when one axis folds back and others continue to run normally.

In the most common method of detecting a jam, the controller shuts down the system if the actual position is significantly different from the commanded position. All servo applications should include a position error shutdown, if possible.

If your controller cannot detect a jam, or if you need to limit peak torque in your system, you should use the foldback circuit.

##### **CURRENT FOLDBACK—HOW DOES IT WORK?**

The OEM670/OEM675 does not directly measure motor temperature. Instead, it uses an electrical circuit to model the motor's thermal performance. Actual current flows in the motor; a replica of the actual current flows in the foldback circuit. Current in the motor is converted to heat, and the motor temperature rises; current in the foldback circuit charges a capacitor, and the voltage on the capacitor rises. The drive uses the capacitor voltage to represent motor temperature.

The following drawing shows the relationship between current, heat, and temperature in the motor. (For clarity, only positive motor currents are shown.)

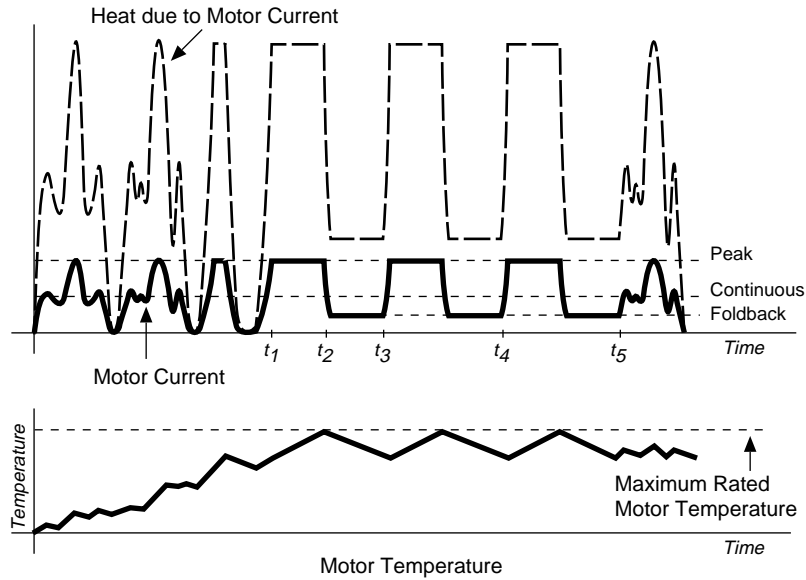

*Current Foldback*

The current waveforms for several moves are shown. The rotor becomes locked at time  $t_1$ , and peak current flows in the motor (for maximum torque). Current is converted to heat, and the motor temperature rises. When the temperature reaches the motor's maximum rating at time  $t_2$ , the foldback circuit takes control, and reduces motor current to a lower level. The motor can then cool down.

At times  $t_3$  and  $t_4$ , the foldback circuit permits full current to flow again. Because the rotor is still locked, the foldback cycle repeats. By time  $t_5$ , however, the rotor has been released. Normal operations can now continue. (Note: Sometimes when the drive goes into foldback, it stays in foldback until the command input voltage is reduced. The system's parameters determine whether the drive goes in and out of foldback, as shown in the drawing above, or stays in foldback.)

While the rotor was locked, the foldback circuit reduced the rate of motor heating.

Notice the relationship between current, heat, and motor temperature. Current is converted to heat in the motor. The

④ **Special Internal Circuits • OEM670/OEM675**

heat's magnitude is proportional to the *square* of the current. As this heat is dumped into the motor, the motor's temperature rises. The temperature is the accumulation, over time, of the net heat in the motor. It is also proportional to the square of the motor current.

You can match the foldback circuit to your particular motor and application by selecting three resistors. The following sections describe the function of each resistor.

**Peak Current:  $I_{pk}$ , R24**

Peak current is the maximum current the OEM670/OEM675 will produce in the motor. You can set it as high as 12 amps. For Compumotor SM motors with "A" windings, and NeoMetric motors with "D" or "E" windings, recommended peak currents are in the 6 – 10 amp range.

In applications where you wish to limit peak current, or the peak torque applied to mechanical assemblies, use R24 to reduce the peak current the drive supplies to your motor.

**Foldback Current:  $I_{fold}$ , R25**

When the foldback circuit takes control, it reduces motor current to a lower level, which is called the *foldback current*. R25 sets the foldback current level.

To ensure that the rate of motor heating is reduced, the foldback circuit enforces a limited duty cycle between operations at high current and operations at foldback current. The *average* power in the motor during this period is approximately equal to the power that would be produced if the motor operated at its rated continuous current level for the same period of time.

The motor's continuous current rating specifies the maximum current at which the motor can run indefinitely without overheating. Try to match your motor's current rating to your application and operating conditions.

If you use R24 to limit peak current, be sure to also change R25, so that the foldback current is lower than the peak current.

**Thermal Time Constant:  $T_{c-therm}$ , R23**

Every motor has its own particular winding-to-stator time constant. This is the time it takes for the *motor winding* to reach 63% of its equilibrium temperature, after application of rated current. The time for the *motor case* to reach equilibrium temperature is different, and is usually much longer.

Small motors usually have much shorter time constants than large motors. Heat dumped into a small motor causes a fast rise to the equilibrium temperature. A large motor has a much greater thermal mass—consequently, the same quantity of heat will cause a much lower temperature rise. The large motor can absorb heat over a longer period of time before it reaches its maximum rated winding temperature.

The next drawing shows time constants for a small motor and a large motor.

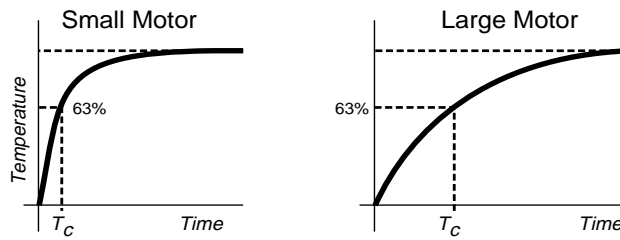

*Motor Time Constant*

The drive uses an electrical circuit to model the motor's thermal characteristics. The next drawing shows the part of the circuit that models the motor's thermal time constant.

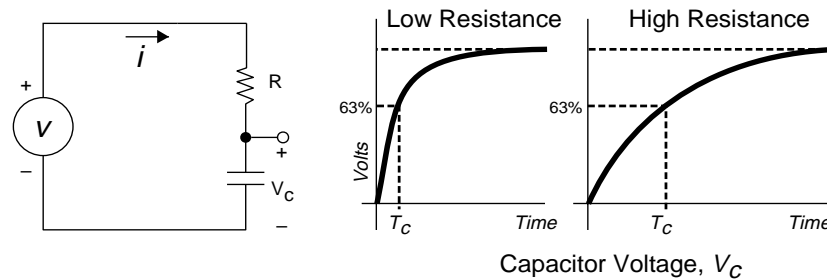

*Foldback Time Constant*

④ **Special Internal Circuits • OEM670/OEM675**

In this circuit, the voltage source  $v$  is proportional to heat in the motor.

$$v \propto (I_{\text{replica}})^2 - (I_{\text{foldback}})^2$$

where

$I_{\text{replica}}$  is a scaled replica of the motor current

$(I_{\text{replica}})^2$  represents heat entering the motor

$(I_{\text{foldback}})^2$  represents heat leaving the motor

$v_c$ , the voltage on the capacitor, represents motor temperature. R23 controls how fast  $v_c$  can change.

If you select an appropriate value for R23, the RC time constant of the circuit will match the thermal time constant of your motor. In the drawing above, the two graphs on the right show that a low resistance produces a time constant similar to a small motor's time constant; a high resistance gives a longer time constant, similar to that in a large motor.

R23, therefore, controls the time constant in the foldback circuit. It is scaled to one second per megohm. Very small motors should use a lower (faster) value for R23. For larger motors that need peak power for long acceleration times, you can increase R23 to as high as 10 megohms. Values higher than this are not recommended.

These points are summarized below.

- SCALING: 1 sec per  $M\Omega$
- MAXIMUM: 10  $M\Omega$

Notice that the time constant *averages* the flow of heat in the motor. This means that previous circuit behavior will affect foldback. If the motor has been working hard, then suddenly demands peak current, the time to foldback will be short. On the other hand, if the motor has been idle much of the time, its average heat will be low. The circuit will recognize this—if the motor demands peak current, the time before foldback occurs will be longer.

As a general guideline, if you reduce R23 by half, then time to foldback will be cut almost in half.



**RESISTOR SELECTION**

The following sections describe three application situations.

- High Torque Permitted / Controller Can Detect a Jam
- High Torque Not Permitted
- Controller Cannot Detect a Jam

To select foldback resistors, determine which of the situations apply to your system, and follow the instructions in the relevant section below.

***High Torque Permitted/Controller Detects Jam***

If your mechanical system can withstand the peak torque of your motor with 12 amps in it, and your controller can detect a jam, you can probably use the resistors in the table below. These resistors allow 12 amps peak current for 0.5 – 2 seconds before foldback occurs (depending on the level of current *before* the peak), and will allow currents up to 6 amps continuously.

**Foldback Resistors for 12A Peak, 6A Continuous**

<u>Res. #:</u>	<u>Function</u>	<u>Resistor Value</u>	<u>Current</u>
R25	Foldback Current	23.7 KΩ	6A
R24	Peak Current	∅ Ω	12A
R23	Time Constant	5.1 MΩ	

To verify that these resistors are suitable for your application, test your system as described below.

If you experience undesired foldback (red LED lights, but goes out when the command input voltage is reduced), the foldback circuit can be disabled by replacing R25 with a 0 – 10 ohm resistor. Even with foldback disabled, you can still limit peak current (and thus peak torque), by installing an appropriate resistor value for R24,  $I_{pk}$ .

***High Torque Not Permitted***

If your mechanical system cannot withstand the peak torque that the OEM670/OEM675 can produce, you can limit peak current, and thus peak torque, with R24. See the *Peak Current* table below for appropriate resistor values.

④ **Special Internal Circuits • OEM670/OEM675**

**Controller Cannot Detect a Jam**

If your controller *cannot* detect a jam, you should determine foldback resistor values appropriate for your application and install them in your drive. When a jam occurs with these resistors installed, the OEM670/OEM675 will reduce the motor current to a lower level. (*OEM670SD/OEM675SD only*: see *CPE – Position Error Limits* in *Chapter 2, Installation*. If the drive does not detect a jam soon enough with position error limits set, then install foldback resistors.)

This mode of operation greatly reduces the rate of motor heating, and allows more time for the machine operator to notice that there is a problem and shut the system down. As a warning to the operator, the red LED on the front panel will be illuminated while the drive is in foldback.

If you use Compumotor servo motors, the table *Resistors for SM and NeoMetric Motors* in *Chapter ② Installation* lists suggested resistors for you to use.

These values will be appropriate for most applications. However, there are many variables that affect the actual motor operating temperature (see the list below in *Application Conditions Affect Foldback*). You may need to adjust these resistors further.

The next table gives resistor values for specific peak currents and foldback currents.

<b>R24, PEAK CURRENT</b>		<b>R25, FOLDBACK CURRENT <math>I_{pk}</math></b>	
(amps)	<u>R24</u>	$I_{fold}$ (amps)	<u>R25</u>
3	845 K $\Omega$	1	1.2 M $\Omega$
4	450 K $\Omega$	2	165 K $\Omega$
5	348 K $\Omega$	3	86.6 K $\Omega$
6	249 K $\Omega$	4	53.6 K $\Omega$
7	182 K $\Omega$	5	34.8 K $\Omega$
8	124 K $\Omega$	6	23.7 K $\Omega$
9	86.6 K $\Omega$	7	16.9 K $\Omega$
10	56.2 K $\Omega$	8	12.3 K $\Omega$
12	$\emptyset$ $\Omega$		

A starting point for  $I_{fold}$  is to choose R25 so that the foldback current is 70% of the motor's continuous current rating.

If you experience “nuisance” foldback where the current is reduced, but the motor is not too hot and no jam exists, try increasing the foldback current.

To disable current foldback, replace R25 with a 0 – 10 ohm resistor. You can still specify peak current with R24—but the drive will never reduce current with R25 below 10 ohms.

#### ***Application Conditions Affect Foldback***

The foldback circuit is well defined, but it is a simplified, approximate model of what actually occurs in the motor. Circuit limitations and differences in application conditions can cause widely varying results.

Some conditions that affect motor temperature are:

- Ambient temperature
- Air flow on the motor
- Heatsinking of motor (size, composition, and temperature of the motor mounting surface)
- Move profile and duty cycle
- Motor core losses

Other conditions may be important in your system.

Because many variables affect motor temperature, we recommend that you treat the suggested resistor values as a starting point in developing your thermal management strategy. You may need to determine the best values empirically. For optimum motor protection, choose values as conservatively as possible. Finally, test your system as described below.

#### ***Application Examples***

If you have a load that is primarily frictional (for example, a spindle drive), you can set the peak current limit resistor, R24, to a value that will keep the current below the continuous current rating of your motor. This will ensure that the current cannot exceed the motor's rating. Check the motor temperature under actual operating conditions.

If you have a load that is primarily inertial (for example, a point-to-point move with low friction), you can set the

#### ④ *Special Internal Circuits • OEM670/OEM675*

foldback current resistor, R25, to a low value that will protect against a jam but still allow full peak current for the acceleration portion of the move. If the move duty cycle is low, the overall average power will also be low, even though the peak power may be quite high. Therefore, you can use a low foldback current setting.

#### TEST YOUR SYSTEM

Once you have selected and installed foldback resistors, you should perform two tests to verify that the foldback circuit adequately protects your motor.

- Measure Motor Temperature
- Simulate a Jam

These tests are described below.

#### ***Measure Motor Temperature***

Measure the motor case temperature under actual operating conditions. Make your measurements after the motor temperature has reached equilibrium (which can take several hours). Compare the results with the motor's ratings.

Compumotor servo motors have an internal thermostatic switch, with normally closed contacts. If the motor windings exceed predetermined temperature levels, the contacts will open. Monitor the thermostatic switch to verify that the contacts remain closed during operating conditions.

#### ***Simulate a Jam to Verify Resistor Values***

Set controller position-error shutdown limits to appropriate values. To avoid motor overheating, follow these steps:

1. With foldback resistors installed, start your test with a cold motor. Command full current while you simulate a jam.
3. Monitor the red LED. It will illuminate when the drive goes into foldback. ***Do not overheat the motor!*** If the drive does not go into foldback when you expect it to, stop the test immediately.
4. Monitor the fault output. It should be low at the start of your test, and should remain low when the drive goes into foldback. (Foldback is the only condition where the red LED illuminates, but the fault output is low.)
5. Watch to see that the drive comes out of foldback, indicated by the red LED turning off. If the drive does not come out of foldback on its own, reduce the command input voltage; the red LED should then turn off.

The results of your test indicate how much time an operator has to shut down the system in the event of an actual jam.

#### **HOW LONG WILL FOLDBACK PROTECT YOUR SYSTEM?**

Ideally, foldback should prevent the motor from overheating under all conditions of improper application. In practice, because of the many variables affecting motor temperature, foldback can only *delay* motor overheating. This will allow more reaction time for an operator or control system to detect that the machine is jammed.

With foldback, the time before motor overheating occurs can be increased from a few minutes to 10 – 30 minutes for large motors, or from seconds to 1 – 2 minutes for small motors.

The degree of expected operator attention is also a factor. If the machine will be running unattended, we strongly recommend you use a controller that can detect a jam. (For the OEM670SD/OEM675SD, we recommend you set tight position error limits.)

If your controller cannot detect a jam, use a conservative approach and select foldback resistors that limit worst-case motor temperature to a safe value for an indefinitely long period of time.

If the machine operator is nearby and will notice within a reasonable period of time that the machine is jammed, you can use a more aggressive approach to selecting resistors. Different resistors may allow higher motor performance, yet still limit the rate of rise of motor temperature so that the operator has time to react, and shut the machine down.

④ *Special Internal Circuits • OEM670/OEM675*