

Compumotor

AR23 Encoder User Guide

Compumotor Division
Parker Hannifin Corporation
p/n 88-008192-01 D



Table of Contents

TABLE OF CONTENTS.....	I
List of Figures.....	iii
List of Tables.....	iv
How To Use This Manual.....	v
Assumptions.....	v
Contents of This Manual.....	v
Installation Process Overview.....	vi
Developing Your Application.....	vii
Conventions.....	vii
CW and CCW.....	vii
Using Commands.....	vii
Highlighted Text.....	vii
Related Publications.....	vii
CHAPTER 1. INTRODUCTION.....	1
Chapter Objectives.....	1
Product Description.....	1
Product Features.....	1
Theory of Operation.....	1
CHAPTER 2. GETTING STARTED.....	5
What You Should Have.....	5
Decoder Options.....	5
Single-Turn vs. Multi-Turn Decoders.....	6
Decoder Resolution.....	6
Configuring the System.....	6
-1 Decoder.....	6
-1 Decoder DIP Switch and Jumper Locations.....	8
-1 Decoder Default Settings.....	10
Description of DIP Switch Functions.....	10
-1 Decoder RS-232C Interface.....	12
-1 Decoder RS-422/485 Interface.....	14
-1 Decoder AX-A Indexer/Drive Interface.....	15
-1 Decoder JSI Controller Interface.....	16
-1 Decoder 8-Bit Parallel Interface.....	17
-1 Decoder 16-Bit Parallel Interface.....	18
-2 Decoder.....	20
-2 Decoder RS-232C Interface.....	21
-2 Decoder 16-Bit Parallel Interface.....	21
-4 Decoder.....	23
-4 Decoder RS-422/485 Interface.....	24
-4 Decoder JSI Controller Interface.....	24
-4 Decoder 8-Bit Parallel Interface.....	25
CHAPTER 3. INSTALLATION.....	27
Chapter Objectives.....	27
Environmental Considerations.....	27
Mounting.....	27
Panel Layout Guidelines.....	27
Decoder Mounting.....	28
Encoder Mounting.....	29
System Connections.....	31
Wiring Guidelines.....	31
Cabling.....	32
Power Supply.....	33

CHAPTER 4. APPLICATION DESIGN.....	35
Chapter Objectives.....	35
Application Considerations.....	36
AR23 Operation with a PLC.....	36
Parallel Output Control.....	36
Explanation of Parallel Output Examples.....	37
-1 Decoder 8-Bit Data Output.....	38
Interpreting 8-Bit BCD Output for the -1 Decoder.....	40
Interpreting 8-Bit Binary Output for the -1 Decoder.....	41
-1 Decoder 16-Bit Data Output.....	42
Interpreting 16-Bit BCD Output for the -1 Decoder.....	43
Interpreting 16-Bit Binary Output for the -1 Decoder.....	44
-2 Decoder 16-Bit Data Output.....	45
Interpreting 16-Bit Output for the -2 Decoder.....	46
-4 Decoder 8-Bit Data Output.....	46
Interpreting 8-Bit Output for the -4 Decoder.....	48
Host Computer Operation.....	48
Serial Interface Considerations.....	48
Operating the Serial Interface.....	48
Using Multiple Units on an RS-232C Interface.....	49
Daisy Chaining Three -1 Decoders.....	49
Using Multiple Units on an RS-422/485 Interface.....	51
Multi-Dropping Three -1 Decoders.....	52
Using Multiple Units in Parallel Output Mode (-1 & -4 Decoders).....	54
CHAPTER 5. SOFTWARE REFERENCE.....	57
Chapter Objectives.....	57
Command Descriptions.....	57
Command Listing.....	59
CHAPTER 6. HARDWARE REFERENCE.....	67
Chapter Objectives.....	67
AR23 System Specifications.....	67
Mechanical.....	67
Electrical.....	67
Environment.....	68
-1 Decoder Box Pin Out.....	69
-2 Decoder Box Pin Out.....	70
-4 Decoder Box Pin Out.....	71
Decoder Box Dimensions.....	72
-1 Decoder.....	72
-2 Decoder.....	74
-4 Decoder.....	75
-1 Decoder Box DIP Switch and Jumper Settings.....	81
Numbering Code Table.....	82
CHAPTER 7. MAINTENANCE & TROUBLESHOOTING.....	83
Troubleshooting.....	83
RS-232C Communications(-1 & -2 Decoders).....	83
RS-422/485 Communications (-1 & -4 Decoders).....	86
Recommended RS-422/485 Interface Devices.....	86
Reducing Electrical Noise.....	86
Error Code Descriptions.....	91
APPENDICES.....	93
Command Summary.....	93
Recommended Third-Party Vendors.....	93
Warranty.....	94
Glossary.....	97
Index.....	101

List of Figures

Figure 1-1. Absolute Encoding Disk	2
Figure 1-2. Cross-Section Sensing Circuit	2
Figure 1-3. Cross-Section of Multi-Turn AR23 Encoder	3
Figure 1-4. Encoder Block Diagram	4
Figure 2-1. -1 Decoder Box.....	8
Figure 2-2. -1 Decoder Box DIP Switch and Jumper Location.....	9
Figure 2-3. -1 Decoder Jumper Default Settings.....	12
Figure 2-4. -1 Decoder RS-232C Serial Communication (-1 Decoder)	12
Figure 2-5. RS-422/485 Full-Duplex Serial Communication (-1 Decoder)	14
Figure 2-6. AX-A Wiring (-1 Decoder)	16
Figure 2-7. JSI Wiring (-1 Decoder)	17
Figure 2-8. 8-Bit Parallel Wiring (-1 Decoder)	18
Figure 2-9. 16-Bit Parallel Wiring (-1 Decoder)	19
Figure 2-10. -2 Decoder Box.....	20
Figure 2-11. RS-232C Wiring (-2 Decoder).....	21
Figure 2-12. -2 Decoder 16-Bit Parallel Wiring (-2 Decoder)	22
Figure 2-13. -4 Decoder Box.....	23
Figure 2-14. RS-422/485 Wiring (-4 Decoder).....	24
Figure 2-15. JSI Interface (-4 Decoder)	25
Figure 2-16. -4 Decoder 8-Bit Parallel Interface (-4 Decoder)	26
Figure 3-1. Panel Layout	27
Figure 3-2. Minimum Width Decoder Box Mounting	28
Figure 3-3. Minimum Depth Decoder Box Mounting	28
Figure 3-4. -F Option for Flange Mounting	30
Figure 3-5. -B, -C, and -D Mounting Options.....	31
Figure 4-1. Byte Pattern For Output Data	36
Figure 4-2. Output Data Types.....	37
Figure 4-3. Timing—8-Bit Parallel Output (-1 Decoder).....	39
Figure 4-4. Timing—16-Bit Parallel Output (-1 Decoder).....	42
Figure 4-5. Timing—16-Bit Parallel Output (-2 Decoder).....	45
Figure 4-6. Timing—8-Bit Parallel Output (-4 Decoder).....	47
Figure 4-7. RS-232C Daisy Chain Configuration	49
Figure 4-8. AR23 Multi-Drop Wiring	52
Figure 4-9. Location of RN8 and RN11 Resistor Packs (-1 Decoder Board).....	55
Figure 4-10. Multiplexing Configuration (-1 Decoder).....	56
Figure 6-1. -1 Decoder Box Pin Out.....	69
Figure 6-2. -2 Decoder Box Pin Out.....	70
Figure 6-3. -4 Decoder Box Pin Out.....	71
Figure 6-4. -1 Decoder Box Dimensions (Minimum Width Mounting)	72
Figure 6-5. -1 Decoder Box Dimensions (Minimum Depth Mounting)	73
Figure 6-6. -2 Decoder Box Dimensions	74
Figure 6-7. -4 Decoder Box Dimensions	75
Figure 6-8. Serial Interface (-1 Decoder).....	76
Figure 6-9. Parallel Control Inputs (-1 Decoder)	77
Figure 6-10. Parallel Outputs (-1 Decoder).....	78
Figure 6-11. Parallel Outputs & Control Inputs (-2 Decoder)	79
Figure 6-12. Parallel Outputs & Control Inputs (-4 Decoder)	80
Figure 6-13. Jumper Default Settings.....	81
Figure 7-1. Disabling the Handshaking Function	85
Figure 7-2. Noise Suppression Devices.....	87

List of Tables

Table 2-1. Decoder Box Power & Options Summary	6
Table 2-2. Ship Kit List (-1 Decoder box)	7
Table 2-3. -1 Decoder Box Default DIP Switch Settings.....	10
Table 2-4. Special Configuration DIP Switch Settings	11
Table 2-5. Ship Kit List (-2 Decoder box)	20
Table 2-6. Ship Kit List (-4 Decoder box)	23
Table 4-1. Mathematic Byte Table (Binary Output)	38
Table 4-2. Mathematical Byte Table (BCD Output)	38
Table 6-1. -1 Decoder Box Default DIP Switch Settings.....	81
Table 6-2. Numbering Codes.....	82
Table 7-1. Error Code Descriptions.....	91

How To Use This Manual

The manual is designed to help you install, develop, and maintain your system. Each chapter begins with a list of specific objectives that should be met after you have read the chapter. This section is intended to help you find and use the information in this manual.

Assumptions

This user guide assumes that you have the skills or fundamental understanding of the following information.

- IBM (or IBM-Compatible) computer experience
- Programmable logic controller (PLC) experience
- The differences between BCD and binary output
- Basic electronics concepts (voltage, switches, current, etc.)

With this basic level of understanding, you will be able to effectively use this manual to install, develop, and maintain your system.

Contents of This Manual

This user guide contains the following information.

Chapter 1: Introduction

This chapter provides a description of the product and a brief account of its specific features.

Chapter 2: Getting Started

This chapter contains a detailed list of the items you should have received with your AR23 shipment. It will help you to become familiar with the system and ensure that each component functions properly. You will learn how to configure the system properly in this chapter.

Chapter 3: Installation

This chapter provides instructions for you to properly mount the system and make all electrical connections. Upon completion of this chapter, your system should be completely installed and ready to perform basic operations.

Chapter 4: Application Design

This chapter will help you customize the system to meet your application needs. Important application considerations are discussed. Sample applications are provided.

Chapter 5: Software Reference

This chapter discusses the X Series commands that are applicable to the AR23. It is divided into two sections. The first section explains command syntax and parameters that affect command usage. The second section contains an alphabetical listing of all commands, with a syntax and command description for each command. Examples are provided for each command.

Chapter 6: Hardware Reference

This chapter contains information on system specifications (dimensions and performance). This chapter may be used as a quick-reference tool for proper switch settings and I/O connections.

Chapter 7: Maintenance & Troubleshooting

This chapter describes Compumotor's recommended system maintenance procedures. It also provides methods for isolating and resolving hardware and software problems. A list of diagnostic codes is included in this chapter.

Installation Process Overview

To ensure trouble-free operation, you should pay special attention to the environment in which the AR23 equipment will operate, the layout and mounting, and the wiring and grounding practices used. These recommendations are intended to help you easily and safely integrate AR23 equipment into your manufacturing facility. Industrial environments often contain conditions that may adversely affect solid state equipment. Electrical noise, atmospheric contamination, or installation may also affect the operation of the AR23 System.

Before you attempt to install this product, you should complete the following steps:

1. Review this entire manual. Become familiar with the manual's contents so that you can quickly find the information you need.
2. Develop a basic understanding of all system components, their functions, and interrelationships.
3. Complete the basic system configuration and wiring instructions (in a simulated environment, not a permanent installation) provided in Chapter 2, Getting Started.
4. Perform as many basic moves and functions as you can with the preliminary configuration. You can only perform this task if you have reviewed the entire manual. You should try to simulate the task(s) that you expect to perform when you permanently install your application (however, do not attach a load at this time). This will give you a realistic preview of what to expect from the complete configuration.
5. After you have tested all of the system's functions and used or become familiar with all of the system's features, carefully read Chapter 3, Installation.
6. After you have read Chapter 3 and clearly understand what must be done to properly install the system, you should begin the installation process. Do not deviate from the sequence or installation methods provided.
7. Before you begin to tune and customize your system, check all of the system functions and features to ensure that you have completed the installation process correctly.

The successful completion of these steps will prevent subsequent performance problems and allow you to isolate and resolve any potential system difficulties before they affect your operation.

Developing Your Application

Before you attempt to develop and implement your application, there are several issues that you should consider and address.

1. Recognize and clarify the requirements of your application. Clearly define what you expect the system to do.
2. Assess your resources and limitations. This will help you find the most efficient and effective means of developing and implementing your application.
3. Follow the guidelines and instructions outlined in this user guide. Do not skip any steps or procedures. Proper installation and implementation can only be ensured if all procedures are completed in the proper sequence

Conventions

To help you understand and use this user guide effectively, the conventions used throughout this manual are explained in this section.

CW and CCW

When a reference is made to a clockwise (CW) or counterclockwise (CCW) movement of the encoder, it is assumed that you are facing the encoder shaft (you are directly in front of the encoder).

Using Commands

Whenever you enter a command on your keyboard, you must enter a carriage return [cr] to prompt the system to process the command. If you are using an IBM computer, an IBM-compatible computer, or a terminal, you can send a carriage return by pressing the Enter key. This will activate processing. In this user guide, you will not be reminded to enter the carriage return. *Generally, all system responses provide a [cr] and line feed [lf].*

Highlighted Text

Italics are to be used to set off important material. Refer to the example below.

Example: Outputs 1 and 2 are user programmable. *Do not use outputs 3 and 4.*

Related Publications

The following publications may be helpful resources.

Parker Compumotor Motion Control Catalog

Schram, Peter (editor). *The National Electric Code Handbook (Third Edition)*. Quincy, MA To receive this publication, contact the National Fire Protection Association (Batterymarch Park, MA 02269)

CHAPTER 1. INTRODUCTION

Chapter Objectives

The information in this chapter will enable you to:

- Understand the product's basic functions and features
- Understand basic motion control concepts and apply them to your application

Product Description

An absolute encoder is a feedback device that provides digital position information corresponding to a mechanical location. This value may be offset and scaled which will be discussed in later sections. This information is independent of the previous value and will output a discrete numeric position.

Product Features

The AR23 absolute rotary encoder provides the following features:

- Industry standard size 23 style
- High-resolution—1,024 or 16,384 discrete positions/rev
- Multi-turn—up to 512 turns at full resolution—8,388,608 total discrete positions
- Microprocessor decoding eliminates user decoding
- Four communication methods
 - BCD (8- or 16-bit words)
 - Binary (8- or 16-bit words)
 - RS-422/485 (ASCII Decimal or Hexadecimal)
 - RS-232C (ASCII Decimal or Hexadecimal)
- Programmable resolutions
- Multiple encoders may be multi-dropped via RS-422/485
- Microprocessor monitors for errors and sensor failure
- Compatible with AX-A microstepping indexer/drive (1,024 positions/rev only)

Theory of Operation

The output data is obtained when light shines through a disk and is detected by a photo-transistor. Figure 1-1 is a top view of this disk (where the light sources will be aimed). The disk is constructed of metal and is arranged in concentric tracks. Each track has an independent LED, and photo-transistor parallel to the disk. This encoder disk has each track phased in a binary ratio to the next. The inside tracks are coarser, and the outside track has the finest resolution.

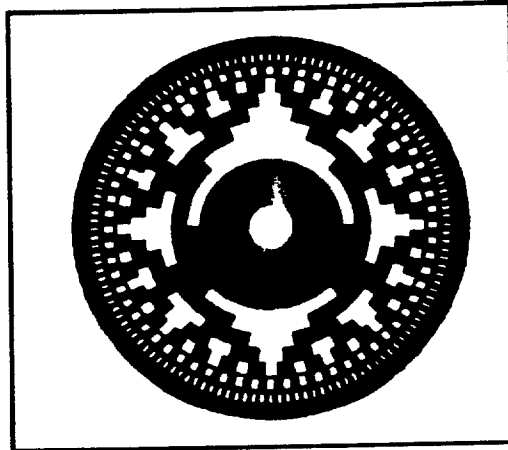

Figure 1-1. Absolute Encoding Disk

Figure 1-2 provides a cross-sectional view of the LED and sensors in relation to the disk. The only moving device is the disk, which is attached to the shaft. As each LED passes an opening on the disk, it causes current to flow to the output circuit. The output circuit is then in a high state. The lights that are blocked by the track have no current flow to the output circuit, which causes a low state. The output circuit then assigns a number for these high and low states. A high signal is assigned with a one (1) and a low signal is assigned with a zero (0). Each high or low (1 or 0) value per light is referred to as a bit. Most encoders use ten tracks on the encoding disk to obtain ten bits of positional data. With the AR23, redundancy encoding is employed, which eliminates uncertainty between positions. In this case, only mechanical motion is allowed to change the position. This is commonly referred to as redundant gray code. This form of encoding has been developed by Compumotor using the disk shown in Figure 1-1.

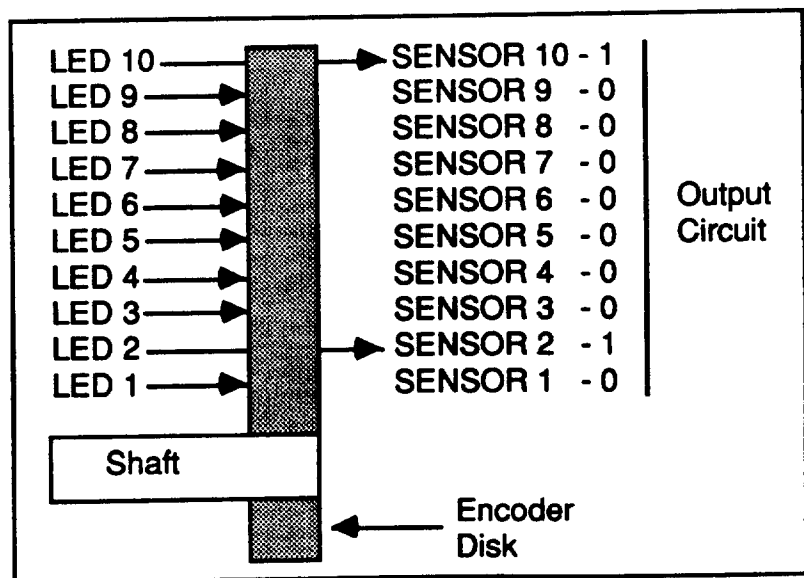

Figure 1-2. Cross-Section Sensing Circuit

Single-turn absolute encoders provide discrete position output for one shaft revolution. Multi-turn absolute encoders provide discrete position output for numerous shaft revolutions.

You can obtain multi-turn information with the construction shown in Figure 1-2 and gearing up the primary encoder disk. As in the AR23, three additional geared disks are added to increase the amount of position data. By adding three 8:1 (8 x 8 x 8) geared disks, the absolute travel increases to 512 turns. Figure 1-3 depicts an AR23 with multi-turn geared disks added.

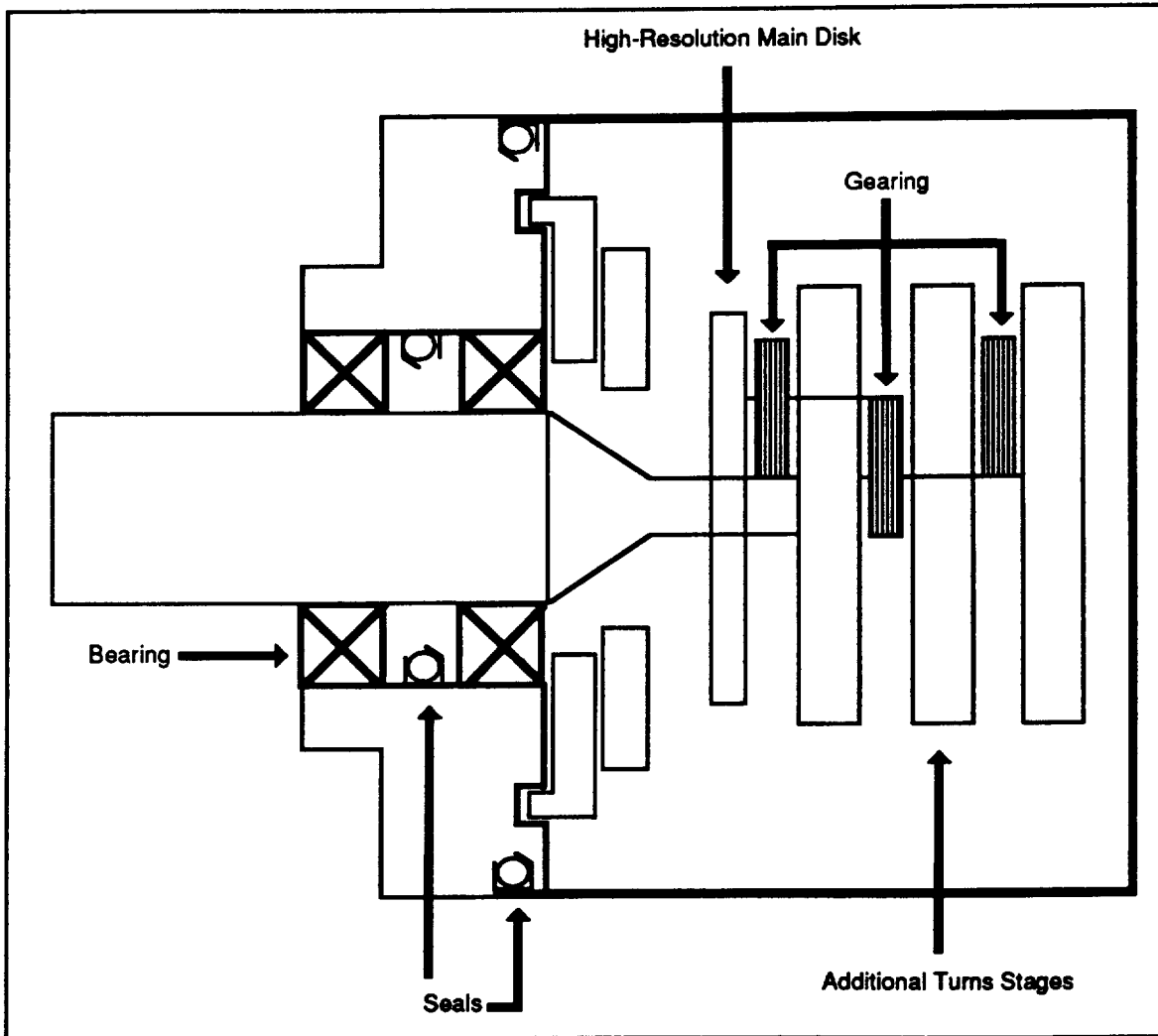

Figure 1-3. Cross-Section of Multi-Turn AR23 Encoder

Each geared disk has its own concentric tracks for turns counting. With three tracks, LEDs, and photo detectors, a discrete count can be maintained for 0 - 7 revolutions of the gear. With 14 bits of resolution, the number of discrete positions increases to 8,388,608 over the total 512 turns.

The redundant gray code data from the AR23 encoder head, whether single or multi-turn, is provided to the AR23's output electronics (decoder box) for interface to the user's control system (e.g., AX-A, JSI, computer, PLC, or terminal). With the AR23, this circuit's main function is to decode the redundant gray code to a more useful output format. The microprocessor-based decoder performs error checking, resolution scaling, and data formatting. Figure 1-4 shows a block diagram of encoder system.

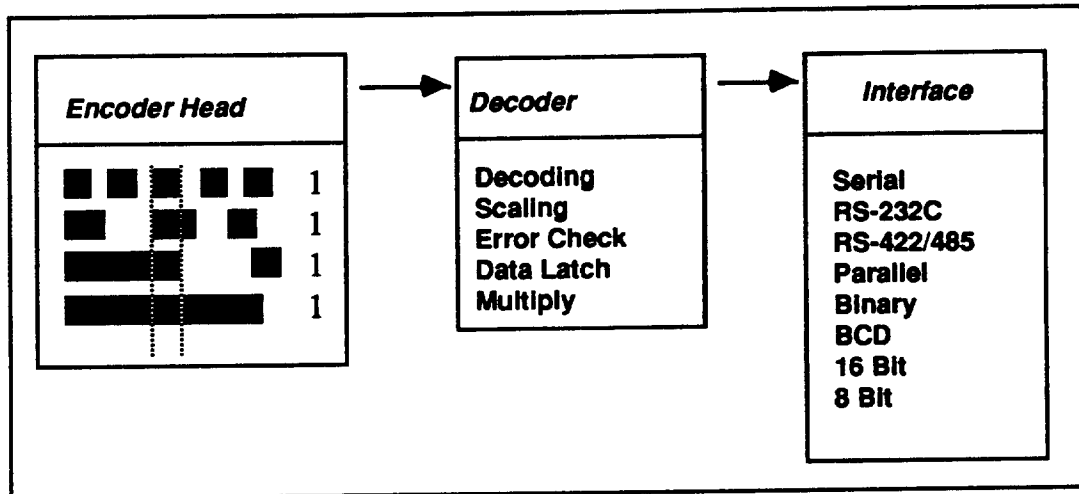

Figure 1-4. Encoder Block Diagram

The encoder signals are transferred to this remote location in a redundant gray code form for a particular position. The processor decodes this information and conforms the position output to the user-selectable format. After this process, you can use this data via a parallel or serial interface. Error checking is a continuously updated feature for encoder status.

Data such as position scale factor, device address, offset, output format, and resolution are maintained in non-volatile electrically erasable programmable read-only memory (EEPROM). The scale factor allows you to obtain data in engineering units. You can use device addresses if more than one unit is interfaced via the serial interface. The serial interface allows you to multi-drop up to 16 units, or daisy chain 4 units from 1 port. If you use more than one decoder in parallel output mode (8-bit or 16-bit), you can *multiplex* the parallel outputs. Multiplexing allows you to share common data and control signals between decoders. You may multiplex as many units as your PLC can handle (refer to Chapter 4, Application Design for detailed information on using multiple units). You can use the offset to define a home position away from a known location. A summary of the commands that define the output data is provided in Chapter 5, Software Reference.

CHAPTER 2. GETTING STARTED

Chapter Objectives

The information in this chapter will enable you to:

- Verify that each component of your system has been delivered safely
- Become familiar with system components and their interrelationships
- Ensure that each component functions properly by bench testing
- Configure the system properly

What You Should Have

You should inspect your AR23 System upon receipt for obvious damage to its shipping container. Report any such damage to the shipping company as soon as possible. Parker Compumotor cannot be held responsible for damage incurred in shipment. Subsequent sections of this chapter contain detailed ship kit lists for each type of configuration that you may have purchased (-1, -2, or -4 Decoder box with AR23 Encoder).

Decoder Options

There are three types of decoder electronics boxes that you can use with the AR23 encoder. Each decoder has a specific set-up procedure that you must successfully complete (depending on the decoder box that you are using) to enable proper operation. The following decoder boxes can be used with the AR23:

- -1 Decoder
- -2 Decoder
- -4 Decoder

The -2 and -4 Decoder boxes do not require you to make any configuration changes (DIP switches and jumpers) to prepare them to operate with the AR23 Encoder. The -1 Decoder configuration, however, can be modified to enable and disable various functions and modes of operation.

Each of these decoders allows you to operate your system with a variety of interface options. Table 2-1 summarizes the interface options available for each decoder. ***If you are not sure which decoder box you have, compare your unit to the decoder front-panel diagrams provided in Figures 2-1, 2-10, and 2-13.***

Decoder Type & Power	Interface Options
-1 (120VAC)	<ol style="list-style-type: none"> 1. RS-232C 2. RS-422/485 3. AX-A Indexer/Drive 4. Digital Servo Controller (JSI) 5. 8-Bit Parallel 6. 16-Bit Parallel
-2 (5VDC)	<ol style="list-style-type: none"> 1. RS-232C 2. 16-Bit Parallel
-4 (5VDC)	<ol style="list-style-type: none"> 1. RS-422/485 2. 8-Bit Parallel 3. Digital Servo Controller (JSI)

Table 2-1. Decoder Box Power & Options Summary

Single-Turn vs. Multi-Turn Decoders

You may purchase any of these decoders as single-turn or multi-turn (refer to Chapter 1, Introduction for a discussion of single-turn and multi-turn decoders). If you purchased a multi-turn encoder, single-turn and multi-turn operation is DIP switch selectable (refer to Table 2-3).

Decoder Resolution

Decoder resolution is factory-set at one of the following levels based on your order:

- 1,024 positions/rev
- 16,384 positions/rev

To operate the AR23 Encoder with the AX-A interface, you must have a **multi-turn -1 Decoder** with a resolution of **1,024 positions/rev**.

To operate the AR23 Encoder with the JSI Controller you must have a **-1 Decoder** or **-4 Decoder**. This interface will only run with the **high-resolution** option and a **multi-turn encoder**.

If you received or ordered a decoder that is not compatible with your system, contact Parker Compumotor.

Configuring the System

Read the following sections carefully for detailed information on how to properly integrate the AR23 Encoder into your system. *Instructions are provided for the three types of decoder boxes that may be used with the AR23 Encoder. You only need to follow the instructions that apply to your application. You may skip configuration instructions that do not apply to your application.*

-1 Decoder

The -1 Decoder box (refer to Figure 2-1) provides several features that the other decoders do not offer.

- Two programmable outputs
- Switch-selectable options
- General status LEDs

The following items should be present and in good condition.

Part	Part Number
AR23 Encoder Head & Cable	
Single-turn*	72-7887-02
Multi-turn*	72-7839-02
-1 Decoder Box	72-8142-01
AR23 Encoder User Guide	88-8192-01
<i>*You will receive one of these two parts depending on your order</i>	

Table 2-2. Ship Kit List (-1 Decoder box)

The red status light goes on when the encoder is at the zero position. This LED will not illuminate for any other fault condition.

The parallel outputs are optically isolated for reliable performance. Each output is an open collector with an internal pull-up resistor (pulled up to +5VDC). *This output should be referenced to the OPTO- (pin #24) for the interface interconnect.*

Output 1 is activated whenever the encoder position reaches its zero position. You can program Output 2 (using the **SL** command) to activate at any position. Refer to Chapter 5, Software Reference for more information on the **SL** command.

The interface options for this unit are enabled and configured with internal DIP switch and jumper settings. This section contains the proper DIP switch and jumper settings for the various interface modes and a simple test routine that you can run to ensure that the system is operating properly.

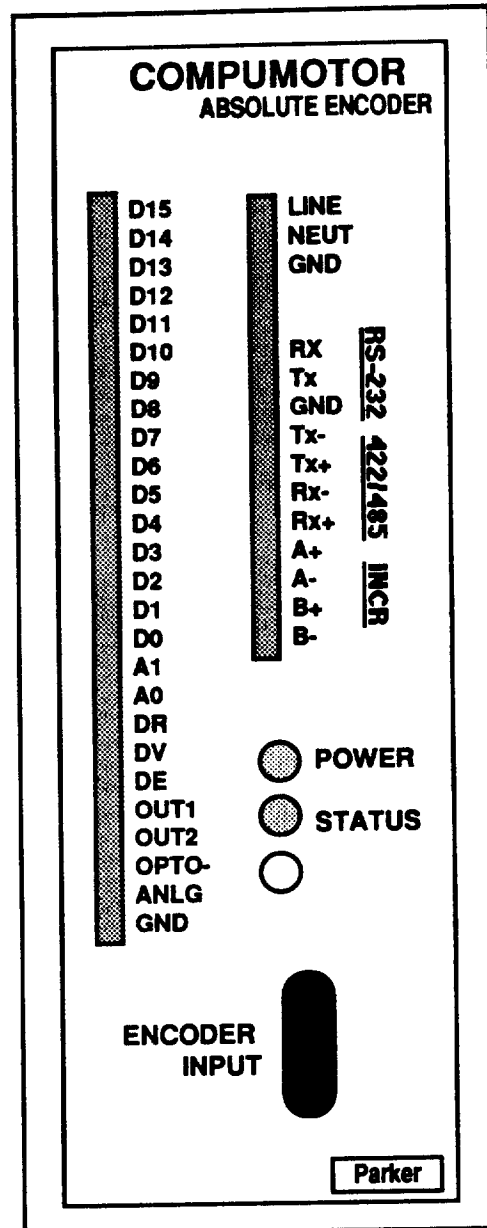

Figure 2-1. -1 Decoder Box

**-1 Decoder DIP
Switch and
Jumper
Locations**

To properly configure the -1 Decoder for your application, you must set the DIP switches and jumpers correctly. To gain access to the DIP switches and jumpers follow the steps described in Figure 2-2 .

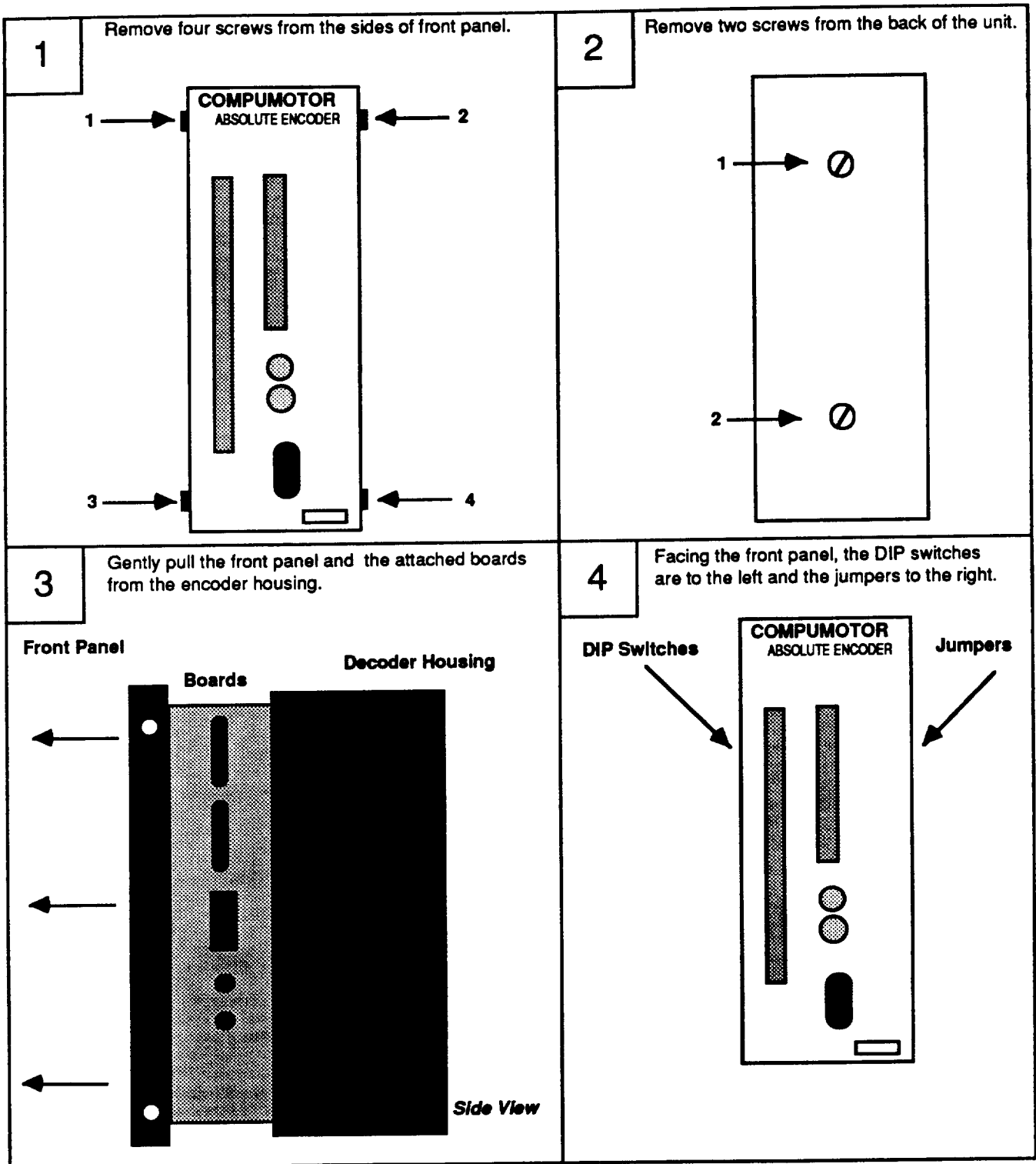

Figure 2-2. -1 Decoder Box DIP Switch and Jumper Location

**-1 Decoder
Default Settings**

Refer to DIP switches marked **S3** on the board (near the top of the board).

Switch #	OFF	ON
S1	RS-232C*	RS-422/485
S2	Full Duplex*	Half Duplex
S3	CCW Direction*	CW Direction
S4	8-Bit Parallel	16-Bit Parallel*
S5	Binary (Hex)*	BCD (Decimal)
S6**	Single turn	Multi-turn
S7	Binary Mode*	Mode Select
S8	Binary Mode*	Mode Select-

*Factory-default setting
**This function is determined by the type of encoder used

Table 2-3. -1 Decoder Box Default DIP Switch Settings

**Description of
DIP Switch
Functions**

The following section describes the function of each -1 Decoder Box DIP switch.

Switch 1

This switch allows you to select one of the two forms of serial communication available with this product—RS-232C (OFF) or RS-422/485 (ON). These forms of communication are Electronic Industry Association (EIA) standards for equipment that employs serial binary data exchange. For more information on the standards associated with these modes of communication, contact:

EIA Engineering Department
Standard Sales
2001 Eye Street N.W.
Washington, D.C. 20006
(202) 457-4966

Switch 2

This switch allows you to select full duplex (OFF) or half-duplex (ON) transmission (*This switch should be ON only if you are using RS-422/485 communications or AX-A mode.*)

Full Duplex mode allows you to transmit and receive data simultaneously via a four-wire facility.

Half Duplex mode allows you to transmit and receive data, but not simultaneously in both directions. This mode of transmission is performed over two wires and is often referred to as *two-way alternate transmission*.

- Switch 3** This switch allows you to determine the encoder's direction. When the switch is OFF, the encoder count increases when the encoder moves in the **CCW** direction. When the switch is ON, the encoder count increases when the encoder moves in the **CW** direction. *This switch does not affect incremental encoder output. If you change this switch setting, you will change (complement) the output encoder position.*
- Switch 4** This switch allows you to select one of the two forms of parallel communication available with this product—8-bit (OFF) or 16-bit (ON).
- Switch 5** This switch allows you to select the form of your output data—binary (OFF) or BCD (ON) for the parallel interface.
- For the serial interface, you may select the Hexadecimal output format if you turn S5 OFF. You may select the Decimal output format by turning S5 ON. If S5 is OFF (with a serial interface), you may also select Decimal output with the **SP** (Define Data Output) command. This command overrides the DIP Switch setting. With a serial interface, DIP Switch S5 is only operable when the **SP** command is set to \emptyset . Table 6-2 (Chapter 6, Hardware Reference) shows the relationships between decimal, BCD, binary, and hexadecimal numbers.
- Switch 6** This switch is set for you (at the factory) to match the type of encoder that you purchased—single-turn or multi-turn (512 turns).
- Switches 7 & 8** These switches allow you to operate your system in a special configuration (AX-A Drive and JSI Controller compatibility). Refer to Table 2-4 for the appropriate DIP switch settings to make your system compatible with these products.

S 7	S 8	Function
OFF	OFF	Standard Product
ON	OFF	Reserved
ON	ON	JSI Controller
OFF	ON	AX-A Drive/Indexer

Table 2-4. Special Configuration DIP Switch Settings

Jumper Location

The jumpers add or remove various termination resistors depending on the particular interface configuration. The jumpers can be moved up or down or left or right on the pins. Figure 2-3 shows the default jumper settings. Modifications to this setting, depending on your configuration, are discussed later in this user guide.

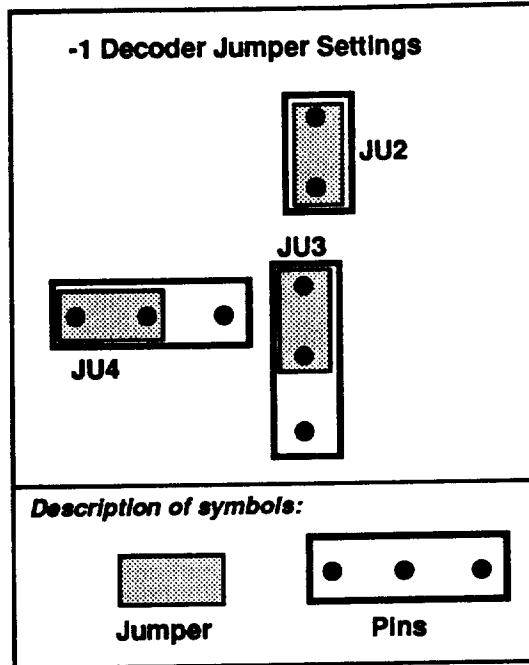

Figure 2-3. Jumper Default Settings

**-1 Decoder
RS-232C
Interface**

This interface communicates serially (with ASCII characters). The 3-wire interconnect and proper DIP Switch settings are shown in Figure 2-4. *Do not change the jumper settings (maintain factory default settings).*

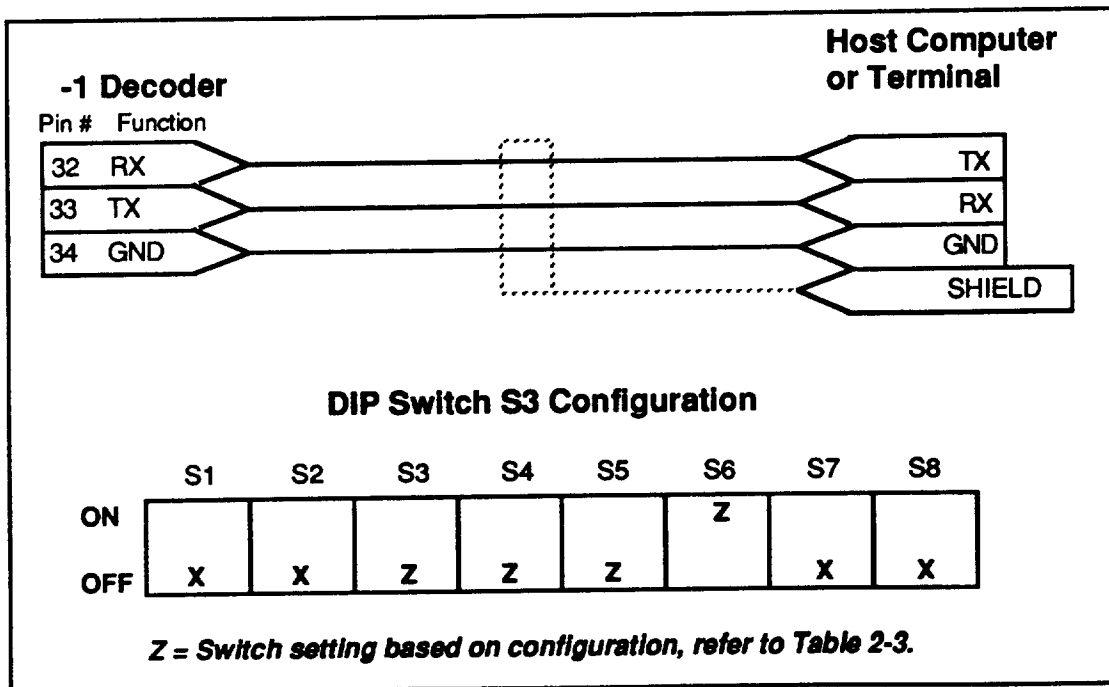

Figure 2-4. RS-232C Serial Communication (-1 Decoder)

**RS-232C
Verification**

To verify that your RS-232C link is operating properly, follow the procedure described below. To perform these steps, you will need a terminal or you may enable your computer to emulate a *dumb terminal*. Emulation packages (e.g., ProComm™) are available that will allow you to use your computer as a terminal. *Only upper-case ASCII characters are valid.*

1. Be sure that power is not applied to the system. Remove the cover from the AR23 decoder and set the DIP switches (refer to Figure 2-4). Put the cover back on the unit before proceeding.
2. Connect the interface from the decoder box to the computer/terminal using the instructions shown in Figure 2-4.
3. Plug the encoder head's 15-pin D connector into the decoder box and use the supplied 120VAC input cable to power up the unit. The green power LED should light up.
4. Enable your computer/terminal to operate at the following specifications:
 - Baud Rate: 9,600
 - Data Bits: 8
 - Start/Stop Bit(s): 1
 - Parity: None
5. After you power up the unit, press the space bar on your keyboard to determine if the computer/terminal is operating properly. If your cursor moves on the screen after you press the space bar, you are receiving an *echo*. An echo indicates that communication is occurring from the computer/terminal to the decoder box and from the decoder box back to the computer/terminal. If you receive an echo, proceed to step 8.
6. If no echo is received, switch the wires labeled Rx and Tx on the decoder box and press the space bar again. If an echo is received, proceed to step 8.
7. If the computer/terminal is still not receiving an echo, refer to Chapter 7, Maintenance & Troubleshooting.
8. After verifying that you have received an echo, type: **ØPR**. You should receive the following response: **Ø_nnnnnnnn** (Ø = an error code, _ = a space, and n = a digit from 0 - 9, A - F which represents the current absolute encoder position in hexadecimal). If you do not receive a report such as this, re-enter the command shown above. After any reset, the first character in the ØPR command's response will be a 1. If you are still unable to obtain the appropriate response, refer to Chapter 7, Maintenance & Troubleshooting.
9. Move the encoder shaft manually and repeat Step 8. The position report should change. If the position report does indicate a change in position, the system is operating properly. Refer to Chapter 5, Software Reference, for further command description information.

**-1 Decoder
RS-422/485
Interface**

This interface communicates serially (with ASCII characters—only upper case characters are valid). The 4-wire interconnect and proper DIP Switch settings are shown in Figure 2-5.

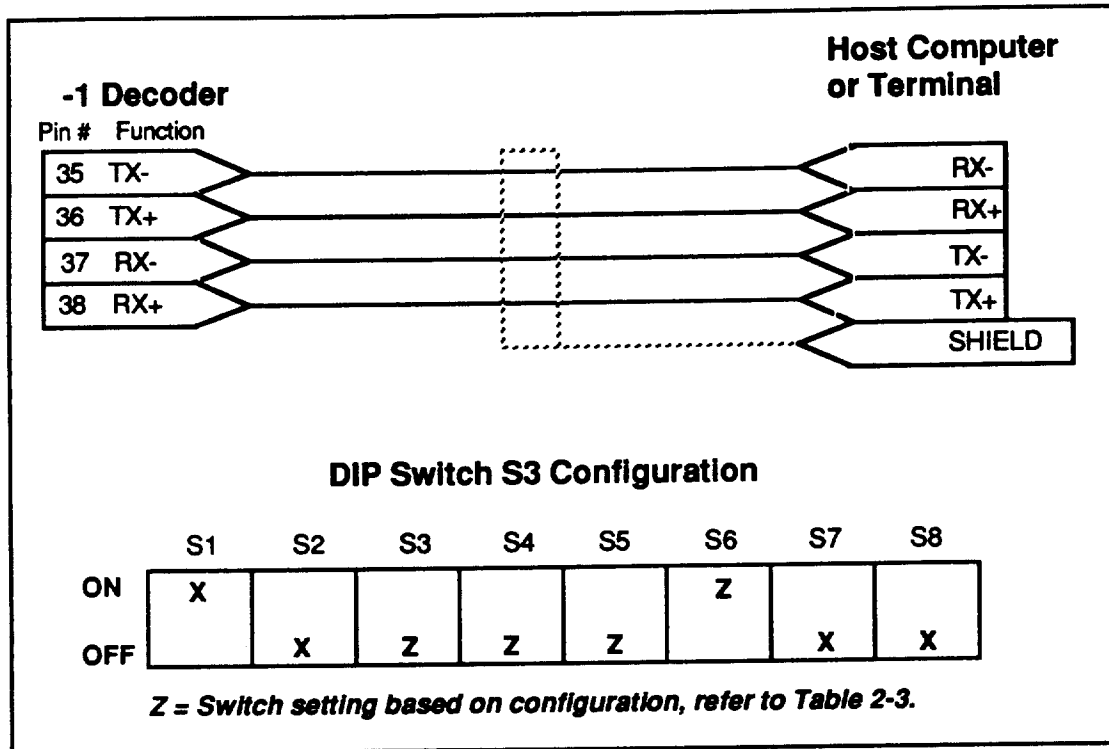

Figure 2-5. RS-422/485 Full-Duplex Serial Communication (-1 Decoder)

You should be aware of the following information if you use the configuration setting shown in Figure 2-5.

- The RS-422/485 interface does not provide character echoes.
- If more than one unit is multi-dropped, remove jumpers JU3 and JU4. *You should do this to all units that you intend to multi-drop, except one.* One unit in the configuration should maintain the default jumper settings (jumper settings only). Refer to Chapter 4, Application Design for more information on multi-drop configurations.

**RS-422/485
Verification**

To verify that your RS-422/485 link is operating properly, follow the procedure described below. Compumotor recommends that you use a Qua-Tech model DS-201/DS-202 if you are using an RS-422/485 interface with an IBM or IBM compatible computer.

1. Be sure that power is not applied to the system. Remove the cover from the AR23 decoder and set the DIP switches (refer to Figure 2-5). If you are using only one unit with this interface, leave the jumpers at their factory default settings. You will have to change all of the other units' jumper settings. Put the cover back on the unit before proceeding.
2. Connect the interface from the decoder box to the computer/terminal using the instructions shown in Figure 2-5.
3. Plug the encoder head's 15-pin connector into the decoder box and use the supplied 120VAC input cable to power up the unit. The green power LED should light up.
4. Enable your computer/terminal to operate at the following specifications:
 - Baud Rate: 9,600
 - Data Bits: 8
 - Start/Stop Bit(s): 1
 - Parity: None
5. After you power up the unit, type the following command: **ØPR** (this command requests a position report from the unit with device Ø). You should receive the following response: **Ø_nnnnnnnn** (Ø = an error code, _ = a space, and n = a digit from 0 - 9 which represents the current absolute encoder position). If you do not receive a report such as this, re-enter the command shown above. If you are still unable to obtain the appropriate response, refer to Chapter 7, Maintenance & Troubleshooting.
6. Move the encoder shaft manually and repeat Step 5. The position report response should change. If the position report does indicate a change in position, the system is operating properly. Refer to Chapter 5, Software Reference, for further command description information.

**-1 Decoder AX-A
Indexer/Drive
Interface**

The AR23 encoder can interface with Compumotor's AX-A Indexer/Drive microstepping package. This interface requires incremental and absolute encoder data. The 7-wire interconnect and proper DIP Switch settings are shown in Figure 2-6. *To operate this configuration, you must remove the jumpers from JU3 and JU4. The jumper on JU2 must be kept in place. Refer to Figure 2-3 for detailed information on jumper location.*

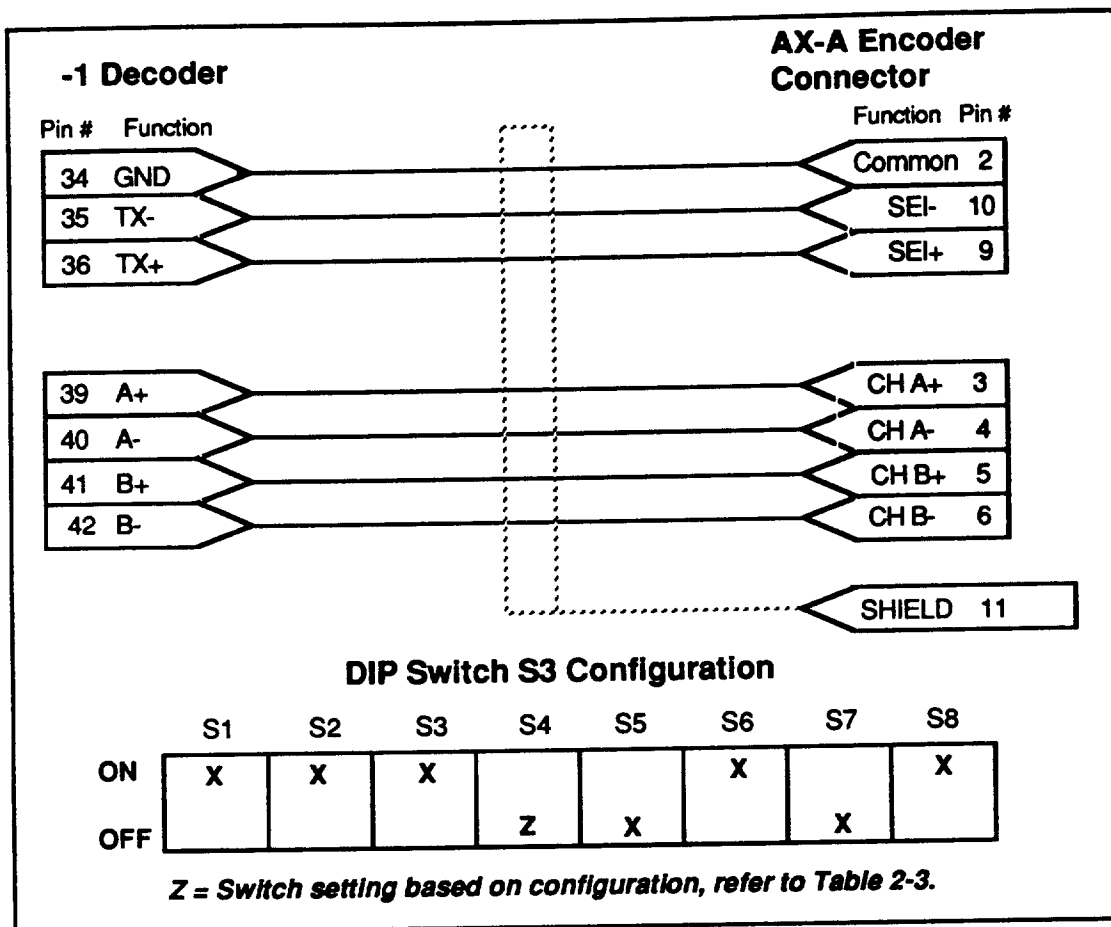

Figure 2-6. AX-A Wiring (-1 Decoder)

AX-A Verification

Before proceeding, be sure that power is not applied to the system. Remove the decoder box cover and set the switches as shown in Figure 2-6. After setting the switches, put the cover back on the decoder. To verify that the AR23 and the AX-A are operating properly together, follow the test procedures provided in the AX-A User Guide.

-1 Decoder JSI Controller Interface

The AR23 encoder can interface with Compumotor's JSI Digital Servo Controller. The interface between these units is performed through the 8-bit parallel mode. The 14-wire interconnect and proper DIP Switch settings are shown in Figure 2-7. *Jumper settings do not affect this configuration.*

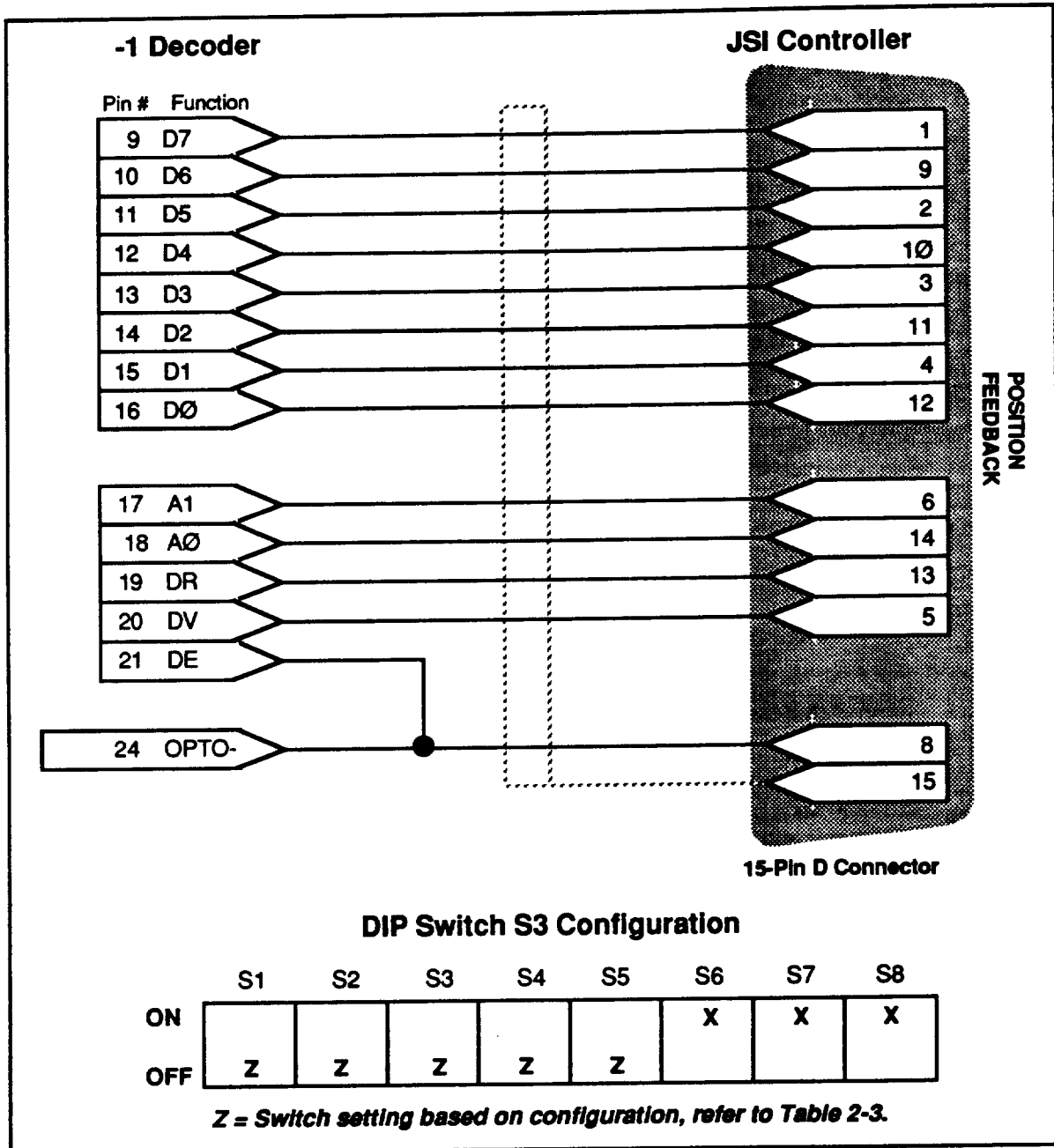

Figure 2-7. JSI Wiring (-1 Decoder)

JSI Verification

Before proceeding, be sure that power is not applied to the system. Remove the decoder box cover and set the switches as shown in Figure 2-7. After setting the switches, put the cover back on the decoder. To verify that the AR23 and the JSI are operating properly together, follow the test procedures provided in the JSI User Guide.

**-1 Decoder
8-Bit Parallel
Interface**

This TTL interface allows you to transfer data at a higher rate of speed than the serial interface options (RS-232C and RS-422/485). The 14-wire interconnect and proper DIP Switch settings are shown in Figure 2-8. *Maintain the factory default jumper settings.*

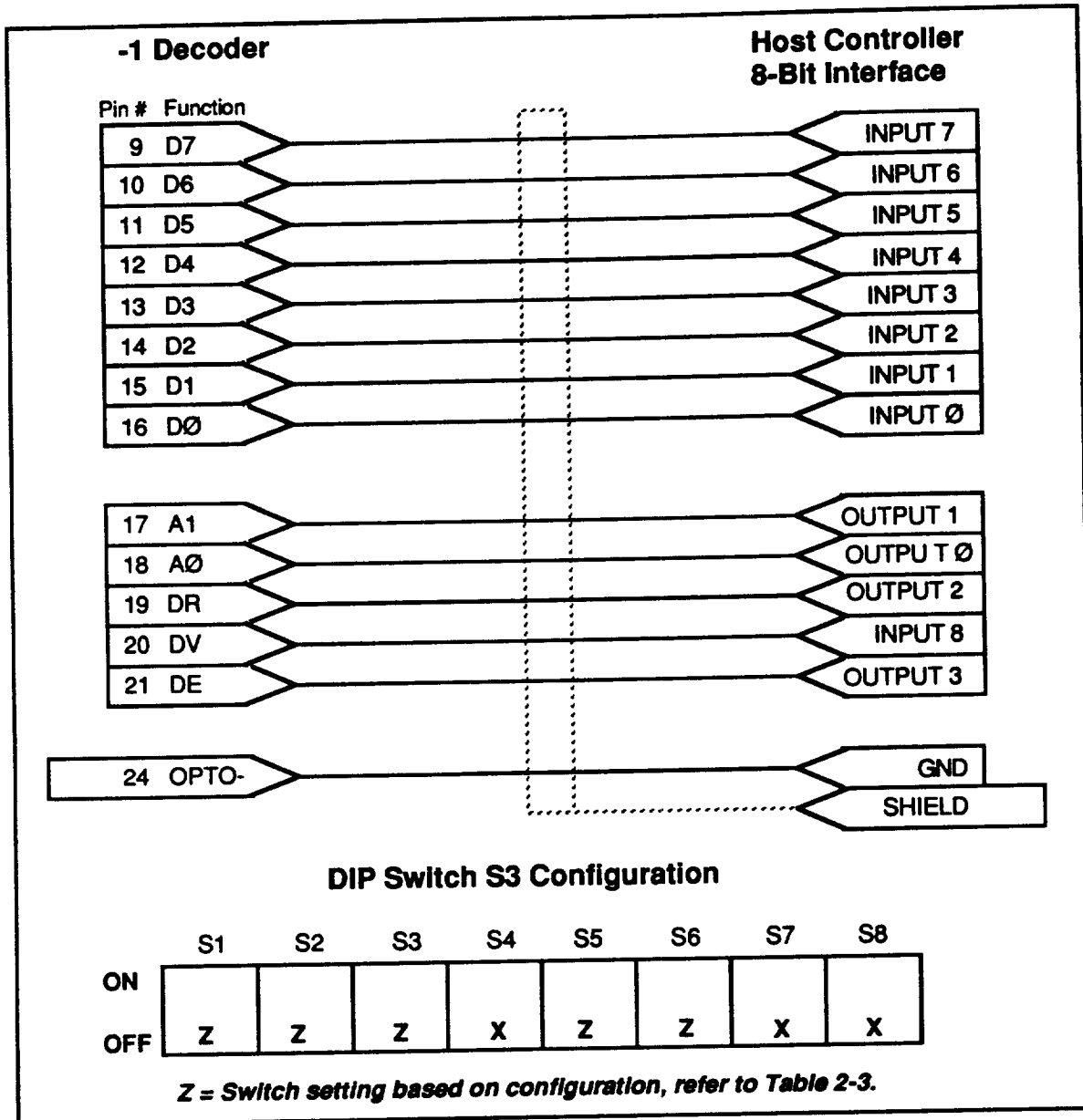

Figure 2-8. 8-Bit Parallel Wiring (-1 Decoder)

8-Bit Parallel Verification

Before proceeding, be sure that power is not applied to the system. Remove the decoder box cover and set the switches as shown in Figure 2-8. After setting the switches, put the cover back on the decoder. To verify that the 8-bit parallel interface is operating properly, refer to Chapter 4, Application Design.

-1 Decoder 16-Bit Parallel Interface

This TTL interface allows you to transfer data at a higher rate of speed than the 8-bit parallel interface. More interface wires are required for this interface. The 21-wire interconnect and proper DIP Switch settings are shown in Figure 2-9. *Maintain the factory default jumper settings.*

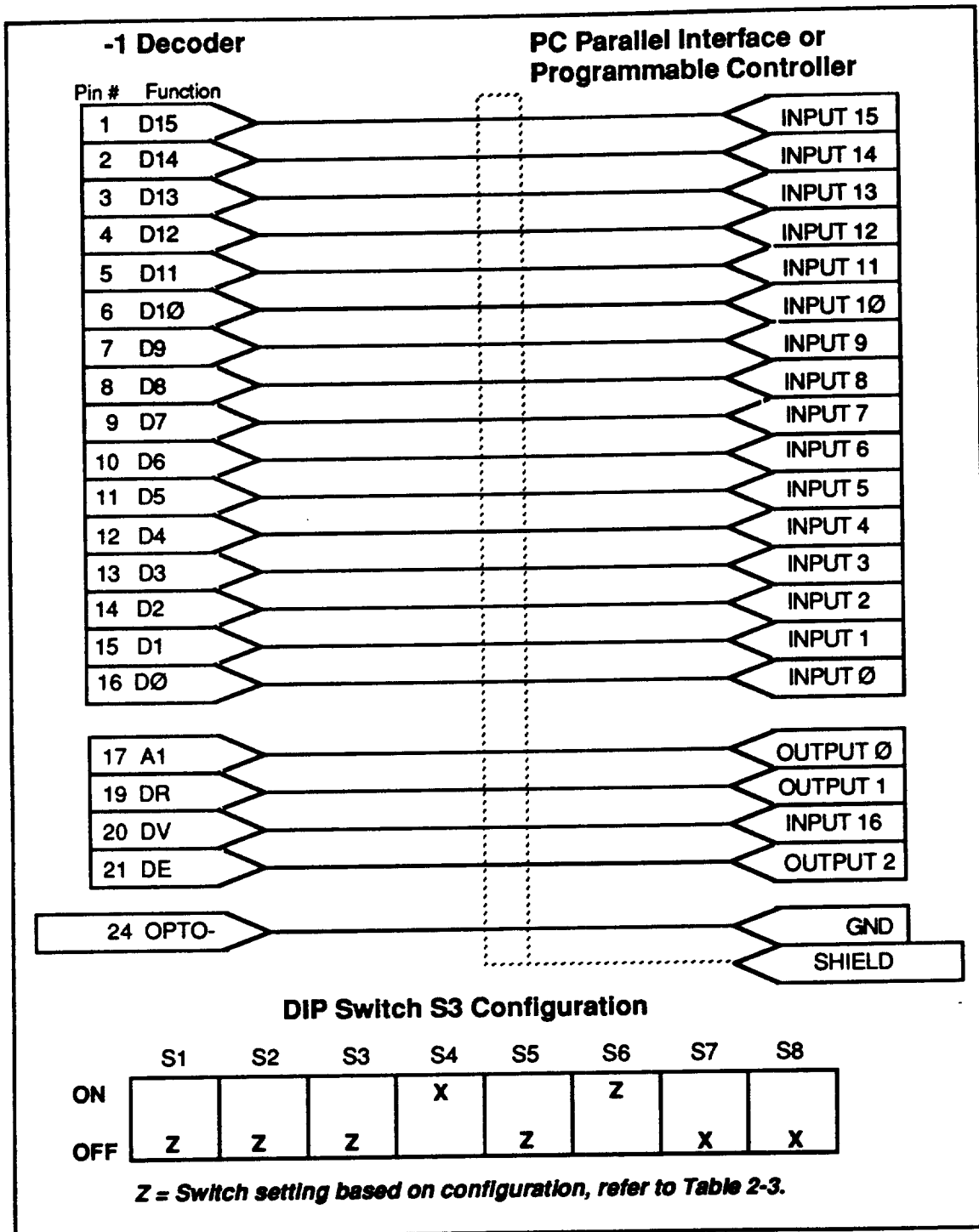

Figure 2-9. 16-Bit Parallel Wiring (-1 Decoder)

16-Bit Parallel Verification

Before proceeding, be sure that power is not applied to the system. Remove the decoder box cover and set the switches as shown in Figure 2-9. After setting the switches, put the cover back on the decoder. To verify that the 16-bit parallel interface is operating properly, refer to Chapter 4, Application Design.

-2 Decoder

The -2 Decoder box (refer to Figure 2-10) provides two interface options. Unlike the -1 Decoder, you will not need to make any DIP switch setting adjustments when you use the -2 Decoder. All of the set-up parameters are configured with the serial interface. The serial interface is RS-232C, and the parallel interface is 16-bit parallel. The following items should be present and in good condition.

Part	Part Number
AR23 Encoder Head & Cable	
Single-turn*	72-7887-01
Multi-turn*	72-7839-01
-2 Decoder Box	72-7938-01
AR23 Encoder User Guide	88-8192-01

**You will receive one of these two parts depending on your order*

Table 2-5. Ship Kit List (-2 Decoder box)

You do not need to make any additional configuration modifications to enable either interface. Either option can be used independently. You may have to modify the configuration to obtain the data format that you require.

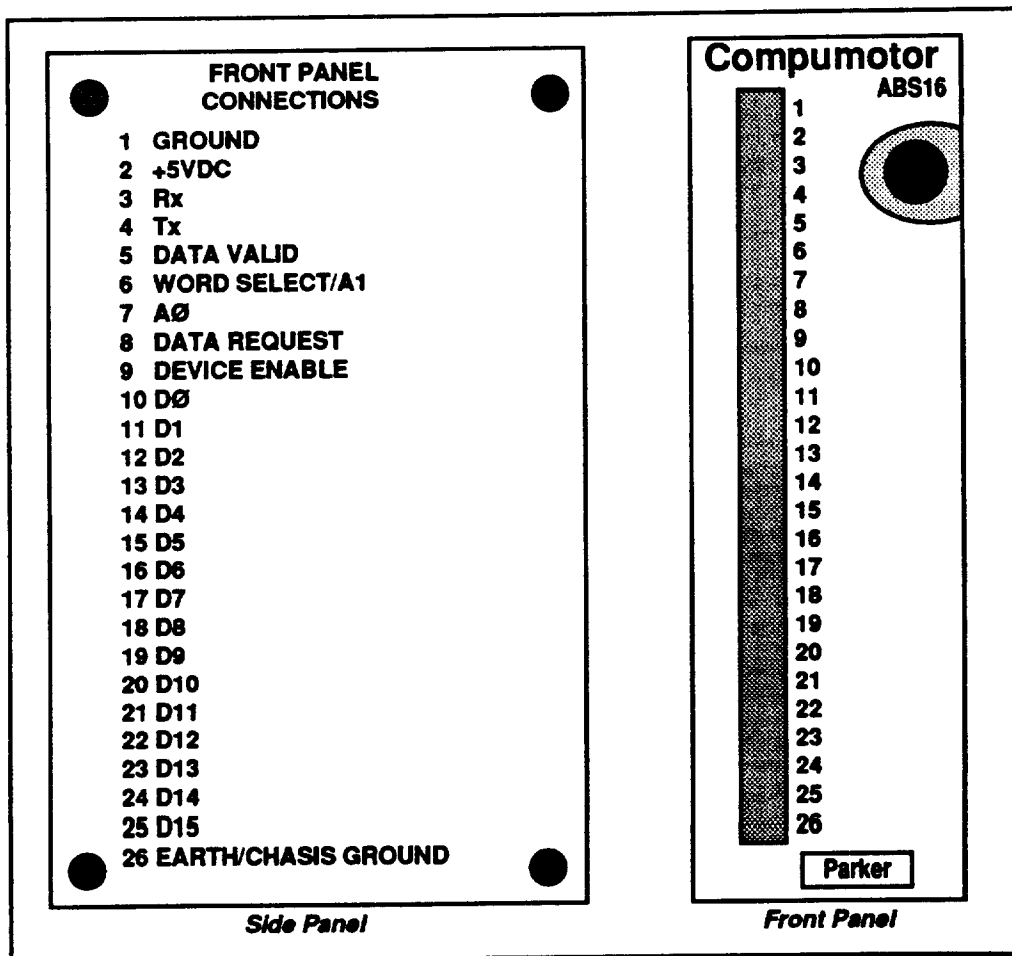

Figure 2-10. -2 Decoder Box

-2 Decoder RS-232C Interface

The 3-wire interconnect for the serial RS-232C interconnect is shown in Figure 2-11.

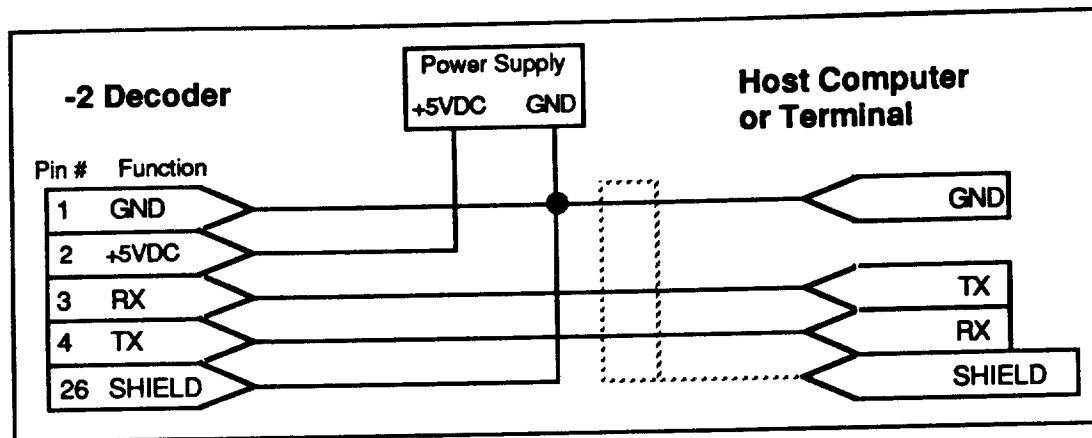

Figure 2-11. RS-232C Wiring (-2 Decoder)

RS-232C Verification

To verify that your RS-232C link is operating properly, wire the system as shown above and follow **steps 4-9** from the procedure described in the -1 Decoder Box *RS-232C Verification* (earlier in this chapter). To perform these steps, you will need a terminal or you may enable your computer to emulate a *dumb terminal*. Emulation packages (e.g., ProComm™) are available that will allow you to use your computer as a terminal.

-2 Decoder 16-Bit Parallel Interface

This TTL interface allows you to transfer data at a higher rate of speed than the serial interface (RS-232C). The 21-wire interconnect is shown in Figure 2-12. Refer to Chapter 4, Application Design for detailed implementation examples.

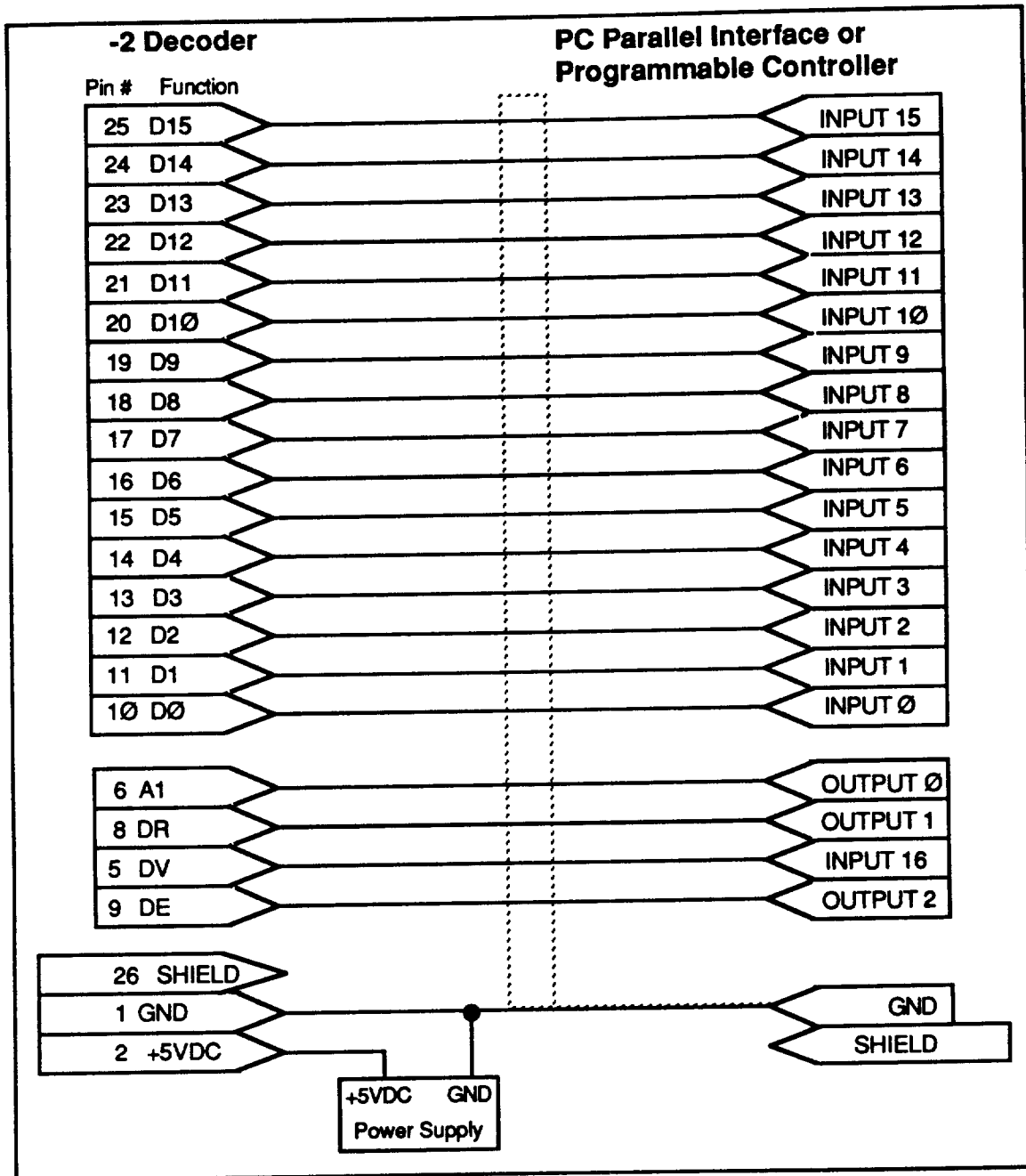

Figure 2-12. 16-Bit Parallel Wiring (-2 Decoder)

-4 Decoder

The -4 Decoder box (refer to Figure 2-13) provides two interface options. You will not need to make any DIP switch setting adjustments. All of the set-up parameters are configured with the serial interface. The serial interface is RS-422/485 and the parallel interface is 8-bit parallel. The following items should be present and in good condition.

Part	Part Number
AR23 Encoder Head & Cable	
Single-turn*	72-7887-01
Multi-turn*	72-7839-01
-4 Decoder Box	72-7937-01
AR23 Encoder User Guide	88-8192-01
<i>*You will receive one of these two parts depending on your order</i>	

Table 2-6. Shlp Kit List (-4 Decoder box)

Either interface option can be used independently. You may have to modify the configuration to obtain the data format that you require.

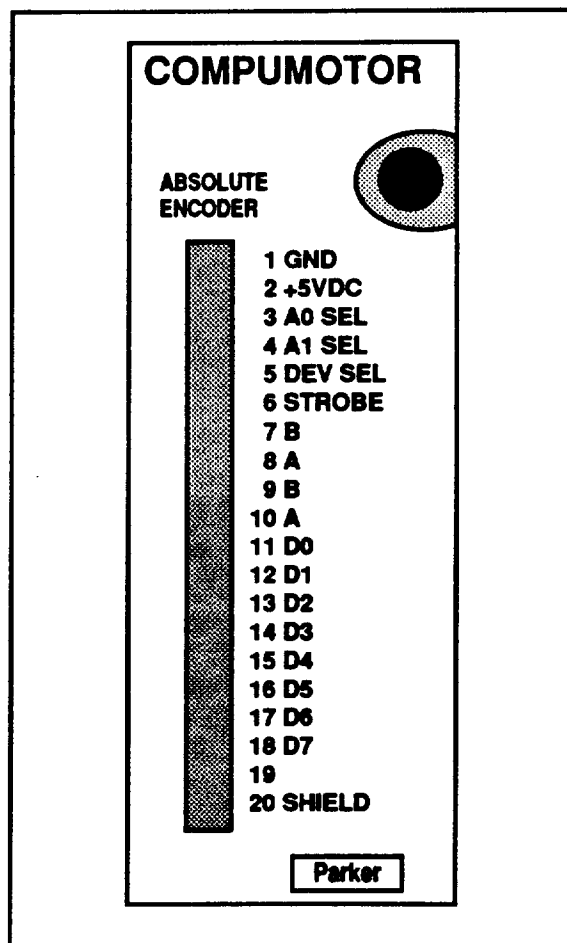

Figure 2-13. -4 Decoder Box

**-4 Decoder
RS-422/485
Interface**

The 4-wire interconnect for the serial RS-422/485 interconnect is shown in Figure 2-14. Refer to Chapter 4, Application Design to determine what parameters (if any) you must alter for your application.

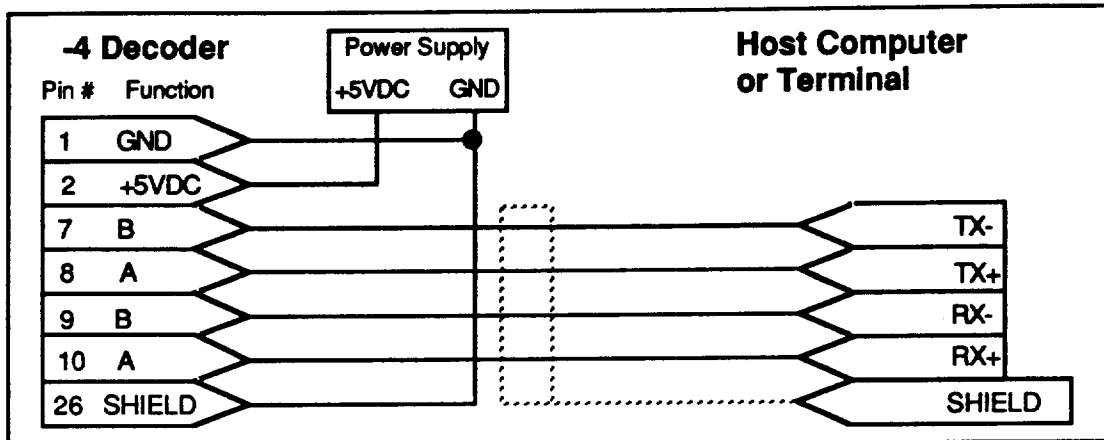

Figure 2-14. RS-422/485 Wiring (-4 Decoder)

**RS-422/485
Verification**

To verify that your RS-422/485 link is operating properly, wire the system as shown above and follow **steps 4-6** from the procedure described in the -1 Decoder Box *RS-422/485 Verification* (earlier in this chapter). To perform these steps, you will need a terminal or you may enable your computer to emulate a *dumb terminal*. Several emulation packages (e.g., Pro-Comm™) are available that will allow you to use your computer as a terminal.

**-4 Decoder JSI
Controller
Interface**

The AR23 encoder can interface with Compumotor's JSI Digital Servo Controller. The interface between these units is performed through the 8-bit parallel mode. The 14-wire interconnect is shown in Figure 2-15. **The 5VDC supply from the JSI will not supply enough current to power the -4 Decoder. You must use an external power supply. Refer to Figure 2-15.**

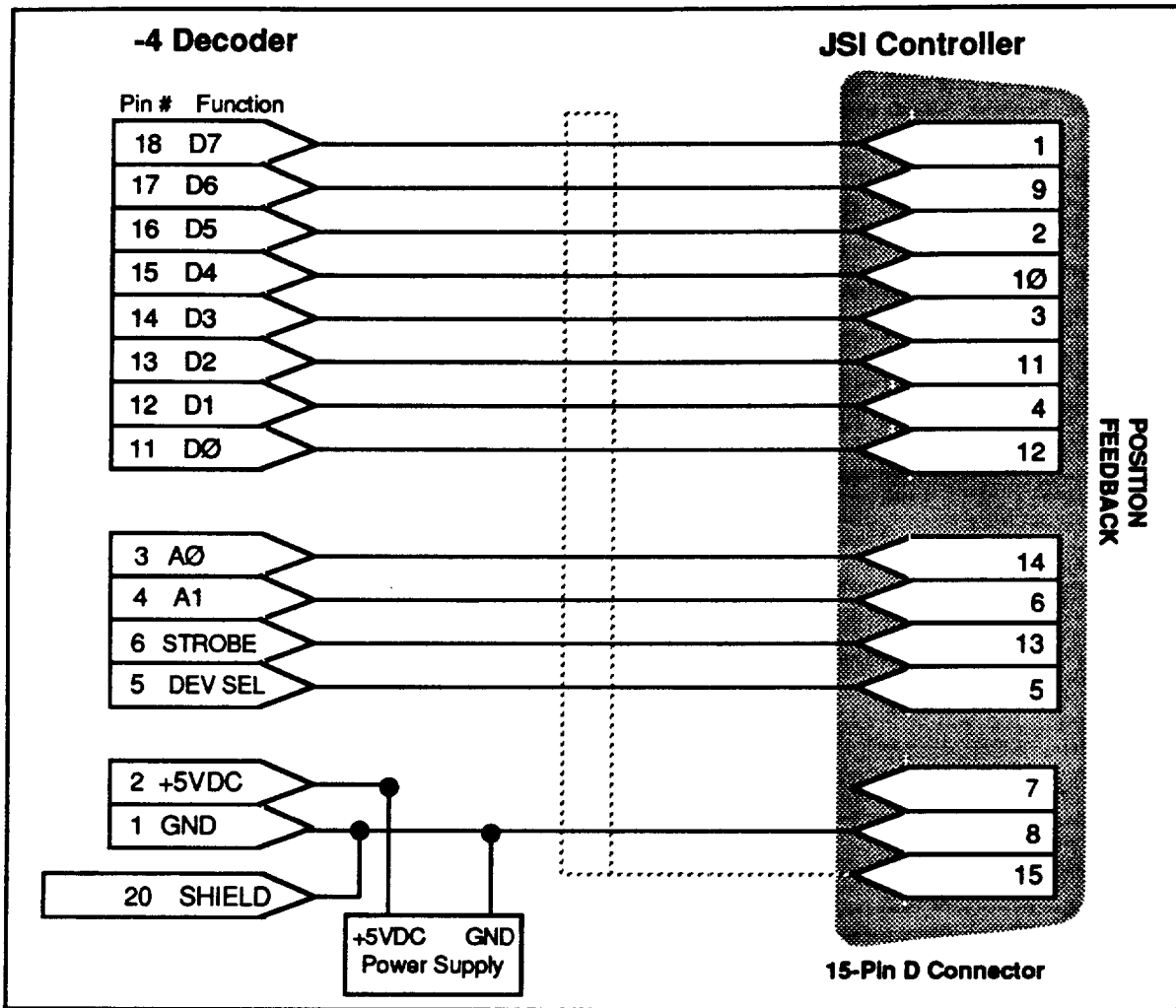

Figure 2-15. JSI Interface (-4 Decoder)

JSI Verification

To verify that the AR23 and the JSI are operating properly together, follow the test procedures provided in the JSI User Guide

**-4 Decoder
8-Bit Parallel
Interface**

This TTL interface allows you to transfer data at a higher rate of speed than the serial interface option (RS-422/485). The 13-wire interconnect is shown in Figure 2-16. Refer to the Parallel Output section in Chapter 4, Application Design for detailed implementation examples.

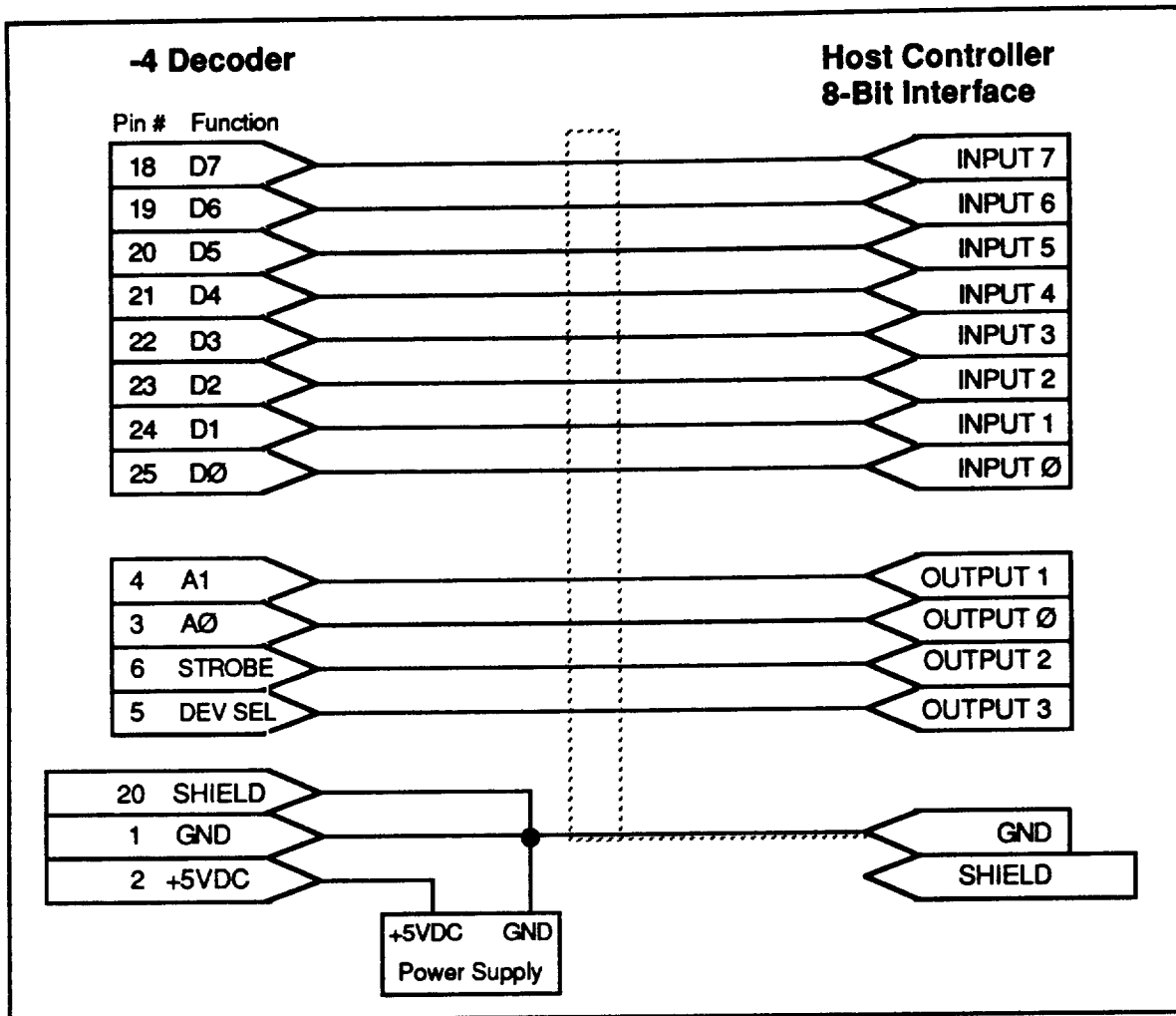

Figure 2-16. 8-Bit Parallel Interface (-4 Decoder)

Chapter 3. INSTALLATION

Chapter Objectives

The information in this chapter will enable you to:

- Mount all system components properly
- Connect all electrical system inputs and outputs properly
- Ensure that the complete system is installed properly

You must complete the steps in Chapter 2, Getting Started that pertain to your application before you perform the steps in this chapter.

Environmental Considerations

The AR23 head has an *O-ring* seal around its housing base, and a sealed cable connection. This sealed connection prevents fluid from penetrating the enclosure. It also serves as a dust-proof barrier.

The shaft is supported by two shielded bearings separated by a fluorocarbon seal. Fluid should not penetrate into the unit through the shaft. You should prevent direct fluid flow onto the unit by altering the flow of fluids. You can accomplish this with a splash guard or some other protective device.

Mounting

Refer to Chapter 6, Hardware Reference for all encoder and decoder box mounting dimensions.

Panel Layout Guidelines

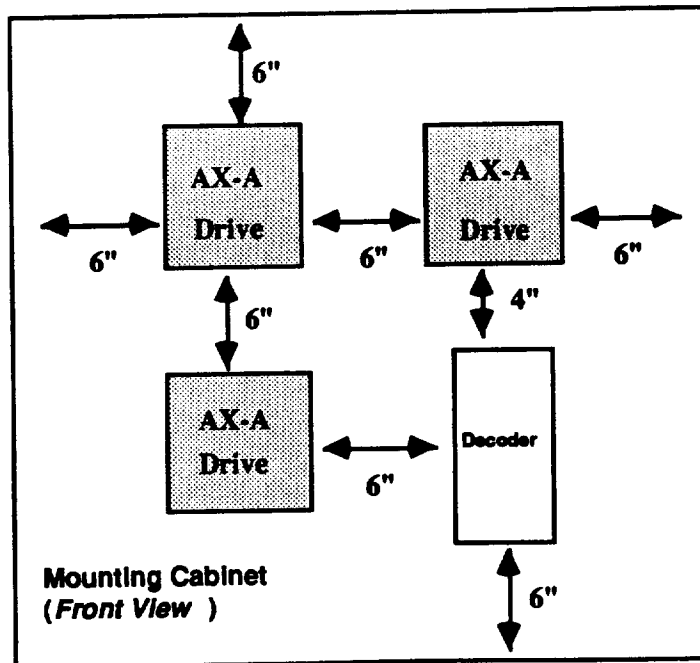

Figure 3-1. Panel Layout

Decoder Mounting

This circuitry is microprocessor based and fully digital (all voltages are within TTL levels). For this reason, the unit should be enclosed within a panel with other control devices. Electrically noisy devices should be suppressed, or housed in separate enclosures (whenever possible).

The electronics box is panel-mounted with two mounting brackets. Chapter 6, Hardware Reference, provides mounting hole dimensions. You may mount the -1 Decoder box in two ways: minimum width or minimum depth. Refer to Figures 3-2 and 3-3. You can only mount the -2 and -4 Decoders as shown in Figure 3-2.

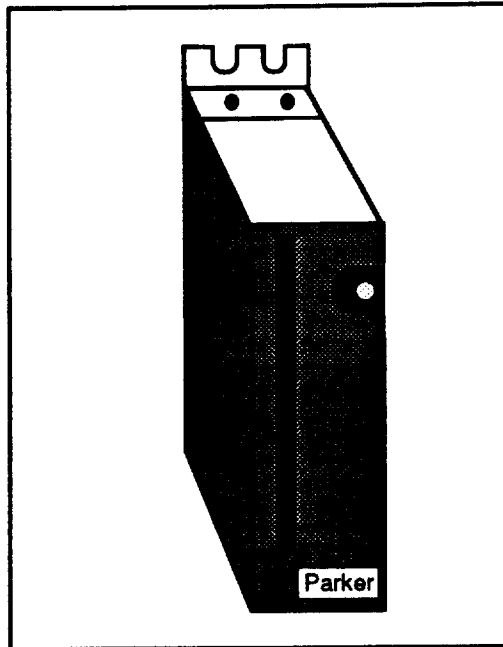

Figure 3-2. Minimum Width Decoder Box Mounting

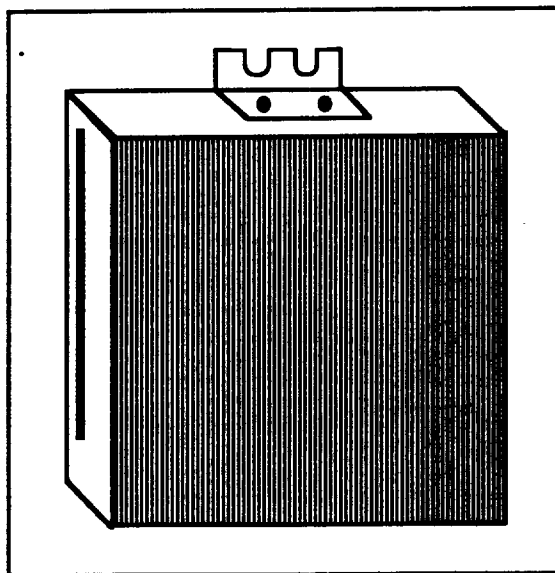

Figure 3-3. Minimum Depth Decoder Box Mounting

Since there are no high-power devices in this circuitry, the box gives off very little heat. However, the unit is not over-temperature protected and must be kept in an ambient environment below 50°C. To maintain this temperature, you may need to vent the enclosure (fan cooling may be necessary if the internal temperature reaches the upper limit). *Logic devices may perform unpredictably if they become too hot.*

Encoder Mounting

The encoder can be mounted by employing one of three possible methods. These options are listed below.

- 1 Standard servo mount; tapped holes on the encoder face on a 1.865" bolt circle, with #6-32 tapped holes.
- 2 The -F option is available for flange mounting. This comes connected to the AR23 providing square construction with unthreaded bolt holes on a 2.741" bolt circle. Refer to Figure 3-4.
3. The -B, -C, and -D options are available for NEMA size stepper motors (Refer to Figure 3-5). This includes the mounting bracket for the encoder and the necessary coupling and screws.
 - -B = NEMA 23 motor
 - -C = NEMA 34 motor
 - -D = NEMA 42 motor

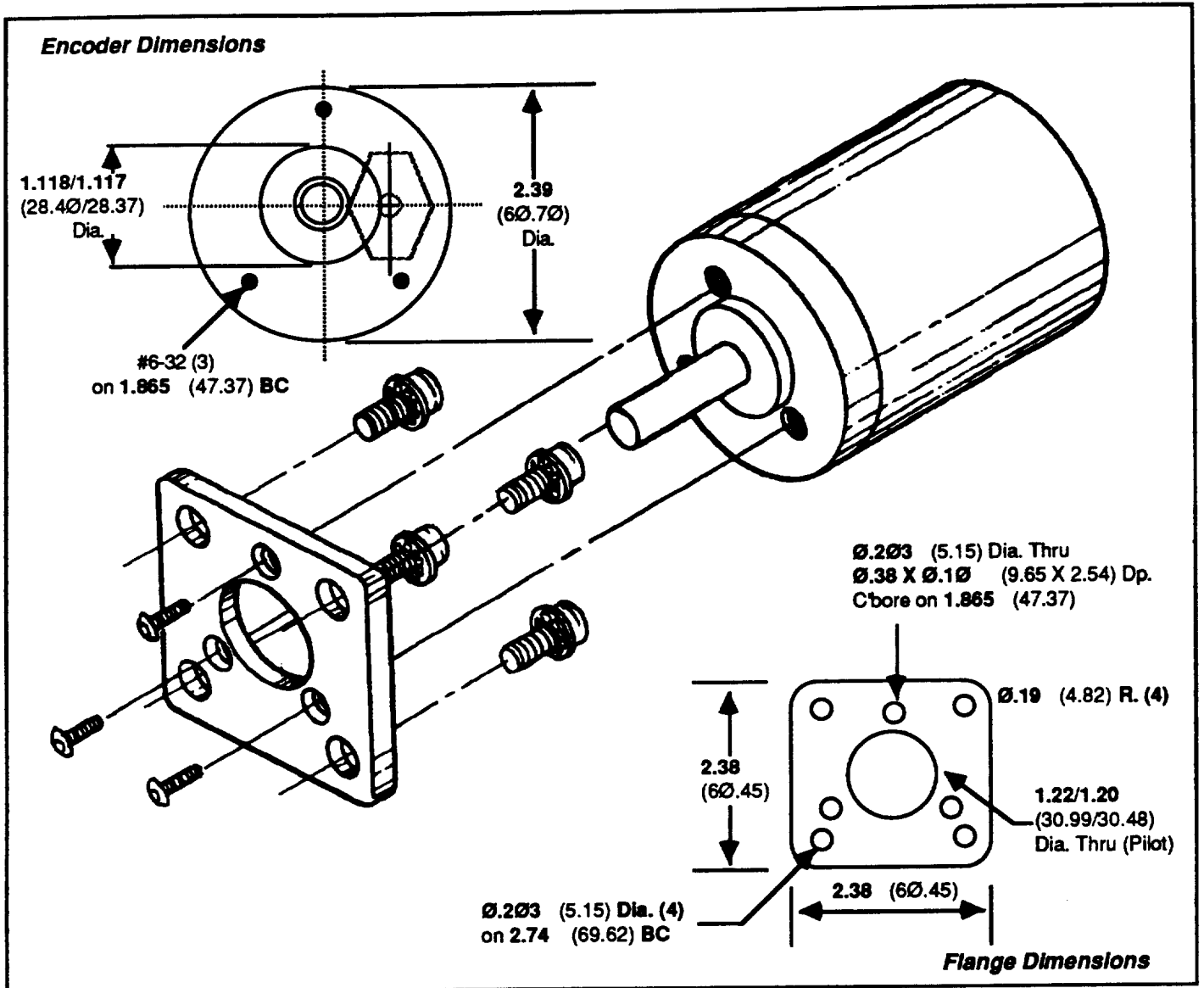

Figure 3-4. -F Option for Flange Mounting

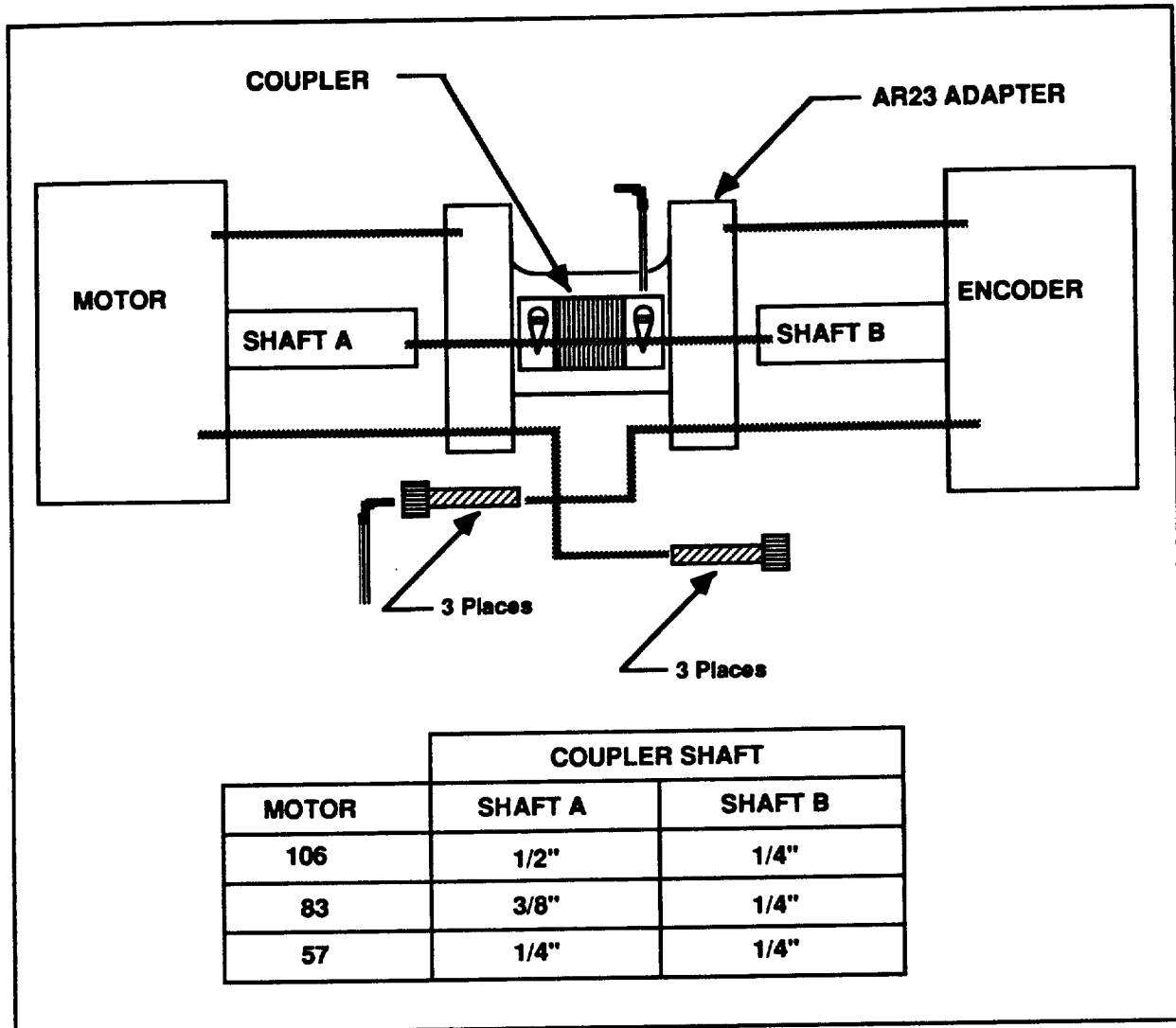

Figure 3-5. -B, -C, and -D Mounting Options

Refer to Chapter 6, Hardware Reference for all dimensional data for the mounting options described above.

System Connections

Wiring Guidelines

This section contains directions and procedures to complete all of the AR23's electrical connections. Refer to Chapter 2, Getting Started for specific I/O locations.

Proper grounding of electrical equipment is essential to ensure the safety of personnel. You can reduce the effects of electrical noise due to electromagnetic interference (EMI) by grounding. All Compumotor equipment should be properly grounded. A good source of information on grounding requirements is the National Electrical Code published by the National Fire Protection Association of Boston, Massachusetts.

In general, all components and enclosures must be connected to earth ground through a grounding electrode conductor to provide a low impedance path for ground fault or noise-induced currents. All earth ground connections must be continuous and permanent. Compumotor recommends a single-point grounding setup. Prepare components and mounting surfaces prior to installation so that good electrical contact is made between mounting surfaces of equipment and enclosure. Remove the paint from equipment surfaces where the ground contact will be bolted to a panel and use star washers to ensure solid bare metal contact.

For temporary installation, or when you cannot implement the grounding method described above, connect the GROUND terminal on the AC power connector to the earth ground. Whenever possible, route high-power signals (i.e., motor and power) away from logic signals (i.e., RS-232C, RS-422/485, parallel output) to prevent electrical noise problems.

Drive and Motor Wiring

Refer to the manuals provided with your drive and motor to properly wire these components. Ensure that you have performed this wiring step successfully by following any test routines or verification procedures that your motor/drive installation recommends.

Cabling

The cable from the encoder head to the decoder box is made of 15 conductor #26 gauge wire. These wires are not twisted, but they are shielded. The shield is terminated at the decoder box end and is not connected at the encoder end. The standard length is 10'. The maximum length for -1 Decoders is 50'. The maximum length for -2 and -4 Decoders is 20'.

If you mount the AR23 in an environment that contains fluids, always route the cable down from the encoder. This prevents fluid flow on the cable from penetrating into the encoder housing. The same precaution should be used at the decoder box end.

If the requirements of your application prohibit you from routing the cable downward, loop the cable to prevent any direct fluid flow. You may have to order a longer cable.

To route the cable for the -2 and -4 Decoder boxes, follow the procedure below.

1. Do not remove the cable from the encoder head when routing the cable. This cable is connected internally to the circuit board.
2. The cable should be removed at the decoder box end only.
3. Take the cover off of the decoder box. Slowly remove encoder cable from printed circuit board. This cable should come out easily.

Any modifications to the cable will void the warranty! Please consult Compumotor prior to making any changes.

Power Supply

The -2 and -4 Decoder boxes have the same power supply requirements. Each unit needs +4.85VDC (min) to +5.25VDC (max). The current that the supply should be able to provide is 0.5 A (maximum) per decoder box. Thus, if 10 boxes run parallel from one supply, the power supply should have a minimum rating of 5A.

For most applications, the power supply ground should be allowed to float with reference to earth (no connection to earth ground). Refer to Chapter 6, Hardware reference for further details.

Chapter 4. APPLICATION DESIGN

Chapter Objectives

The information in this chapter will enable you to:

- Recognize and understand important considerations that you must address before you implement your application
- Understand the capabilities of the system
- Customize the system to meet your requirements

You must complete the steps in Chapter 2, Getting Started, and Chapter 3, Installation, that pertain to your application before you perform the steps in this chapter. Examples are provided for the three types of decoder boxes that may be used with the AR23 Encoder. You only need to follow the examples that apply to your application. You may skip examples that do not apply to your application.

Interface Modes

There are two interface modes that allow you to obtain the encoder's position—serial and parallel. The serial interface includes RS-232C and RS-422/485. The parallel interface includes 8-bit and 16-bit output. Prior to using either interface, you must define certain parameters within the unit for the application.

These parameters configure the format of the information to be provided to the control system. You must define all of the commands that are available for configuration with the serial interface. These commands include configuration for the following functions:

- Report format
- Position scaling
- Position offset
- Output interface

Factory default values, which should be suitable for most applications, are provided. These default values, as well as the configuration command descriptions, are provided in Chapter 5, Software Reference.

After you configure the encoder, you must save all parameters in non-volatile memory. This chapter provides detailed procedures for using the interface modes for each decoder box. The information is divided into two modes of operation: PLC (Parallel) and host-computer (serial) operation.

Application Considerations

Electrical noise, which can cause an incremental system to miscount, is a minor problem with the AR23. You can eliminate any noise-induced errors by reading the encoder position over again. This provides proper position output (as long as the noise is not severe).

It is always good practice to take precautions to prevent problems from occurring. For this reason, below are some shielding recommendations for various applications.

1. If the 5V logic supply that powers the decoder box has its ground floating from earth ground, connect the encoder cable shield to logic ground. For the -2 Decoder box, connect jumper pin 1 to pin 26. For the -4 Decoder box, connect jumper pin 1 to pin 20.
2. If the 5V logic supply powering decoder box has its ground connected to earth ground, the encoder cable shield should be connected to earth ground at the same point to avoid ground loops.
3. Always tie the shield to only one end instead of both ends. Connecting shields at both ends will cause a ground loop and could cause problems for the microprocessor when current flows in the logic ground (GND).

AR23 Operation with a PLC

Parallel Output Control

This interface can output eight (D0-D7) bits, or sixteen (D0-D15) bits of data, depending on the type of encoder you are using. The full-position output of the AR23 Encoder is 32 bits for multi-turn decoders. This data is read in segments.

All data should be read from the least-significant segment to the most-significant segment. Figure 4-1 clarifies the data's position. The figure shows each portion of the data in bytes.

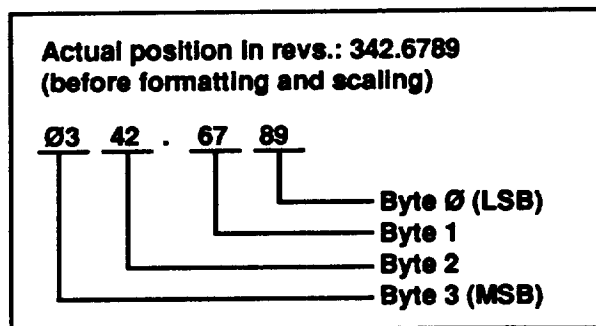

Figure 4-1. Byte Pattern For Output Data

There are three types of data output segments—words, bytes and bits. There are two bytes in each word and eight bits in each byte. Figure 4-2 shows the difference between these segments.

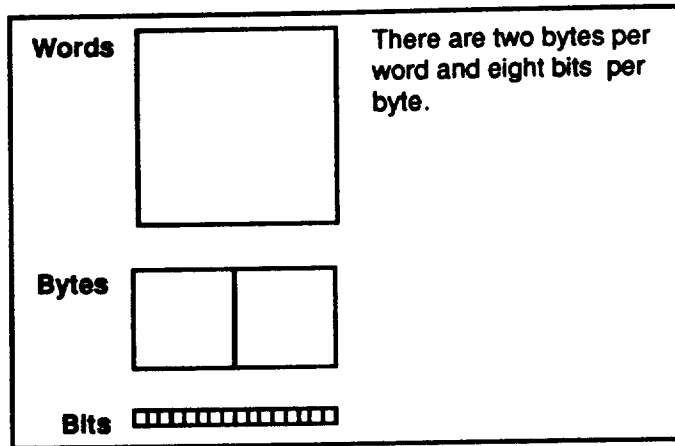

Figure 4-2. Output Data Types

Each output can sink or source up to 15 mA of current, with an output voltage level of +5VDC. The output data can be provided in binary or BCD format. The output format is software selectable with the **SP** command (or hardware selectable with the DIP switches inside the -1 Decoder box). The state of address inputs A0 and A1 determine which segment of position data is to be read.

All inputs are normally high and are pulled up to +5VDC. To activate the inputs, the input must be grounded. Outputs are normally in a high-impedance state with leakage current under 20 μ A. The following sections provide the step-by-step processes required to read data in the the following formats.

- 8-Bit Parallel Output (-1 Decoder)
- 16-Bit Parallel Output (-1 Decoder)
- 16-Bit Parallel Output (-2 Decoder)
- 8-Bit Parallel Output (-4 Decoder)

You only need to read the section that applies to your application.

Explanation of Parallel Output Examples

The examples in this section illustrate how to operate the AR23 to obtain position data in BCD and binary format for 8-bit and 16-bit output (with -1, -2, and -4 decoders). These examples are based on a random position value.

*You must enable the AR23 for one of the output modes (BCD or Binary) with the **SP** (Define Data Output) command before you read the data. If you are using the -1 Decoder, the DIP switch settings must correspond to the settings shown in Chapter 2, Getting Started. You do not need to configure the -2 and -4 Decoders.*

To use the data provided from the encoder, you must convert the decoder's output into position information. Tables 4-1 and 4-2 illustrate the mathematical relationship of each byte being read (in Binary and BCD;). The tables also provide the ratio for 8-bit and 16-bit output. The PLC or computer should read each byte shown in the tables and perform the math functions shown for accurate and meaningful position data.

Binary Output			
BYTE	8-Bit Representation	WORD	16-Bit Representation
1st (LSB)	0-255 units x 1/65536	1st (LSW)	0-65535 units x 1/65535
2nd	0-255 units x 1/256	2nd (MSW)	0-4095 units x 1
3rd	0 - 255 units x 1		(mask error code & sign bit)
4th (MSB)	0-15 units x 256 (mask error code & sign bit)		

Table 4-1. Mathematic Byte Table (Binary Output)

BCD Output			
BYTE	8-Bit Representation	WORD	16-Bit Representation
1st (LSB)	0-99 units x 0.0001	1st (LSW)	0-9999 units x .0001
2nd	0-99 units x 0.01	2nd (MSW)	0-999 units x 1
3rd	0 - 99 units x 1		(mask error code & sign bit)
4th (MSB)	0-9 units x 100 (mask error code & sign bit)		

Table 4-2. Mathematical Byte Table (BCD Output)

-1 Decoder 8-Bit Data Output

This section explains the process of reading a position in 8-bit segments. Wire and configure your decoder (DIP switches and jumpers) as described in Chapter 2, Getting Started (-1 Decoder 8-Bit Parallel Interface). Use DIP switch S5 to select the binary (OFF) or BCD (ON) output format. To read a position (4 bytes) from the AR23 Encoder, refer to Figure 4-3 and follow the steps below.

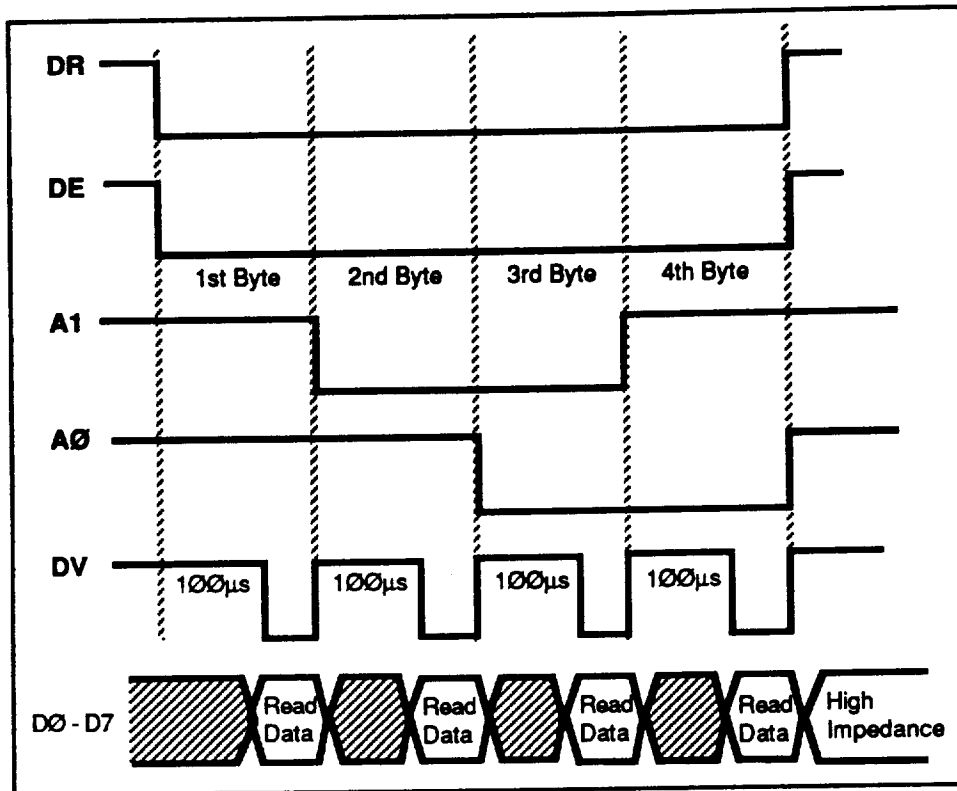

Figure 4-3. Timing—8-Bit Parallel Output (-1 Decoder)

If you are using only one AR23 Encoder, ground the Device Enable (DE) input. The Device Enable function controls when the output goes in or out of a high-impedance state. (This input must be grounded to allow you to read output data from the device.) If you multiplex more than one unit, the Device Enable input will select which output the system will read. The Data Request (DR) output must remain active during the entire data transfer (all four bytes). A1 and A0 select which segment to read. The Data Valid (DV) output provides a signal to you when the data is stable or ready.

- Step 1** Request the first byte (least significant byte—LSB). Bring address selects A0 and A1 high. Ground the Data Request (DR) and Device Enable (DE) outputs.
- Step 2** Wait for the Data Valid (DV) output to go low. *This usually takes approximately 100µs.*
- Step 3** Read the first byte.
- Step 4** Request the second byte. Leave the DR and DE outputs grounded. Leave Address Select A0 high and ground A1.
- Step 5** Wait for the Data Valid (DV) output to go low.
- Step 6** Read the second byte.
- Step 7** Request the third byte. Leave the DR and DE outputs grounded. Leave address select A1 grounded and ground A0.

- Step 8** Wait for the Data Valid (DV) output to go low.
- Step 9** Read the third byte.
- Step 10** Request the fourth byte (most significant byte—MSB). Leave the DR and DE outputs grounded. Leave address select A0 grounded and bring A0 high.
- Step 11** Wait for the Data Valid (DV) output to go low.
- Step 12** Read the fourth byte.
- Step 13** Bring all of the inputs high.

The last three most significant bits (MSB) of the fourth byte contain error code information. Refer to Chapter 7, Maintenance & Troubleshooting for a description of the error codes.

The 4th Byte must always be read. This contains not only the error code, but also the direction indication. This byte will be frozen as long as the data request is active.

If you are using a single-turn encoder, only the first and second bytes contain the encoder's actual position. You must read the third and fourth bytes to obtain error codes.

Interpreting 8-Bit BCD Output for the -1 Decoder

Turn DIP switch 5 (S5) on to select the BCD output format. After the system reads each byte, refer to Table 4-2 (BCD Output) for the mathematic table that corresponds to each byte for the control system. This example assumes that you are using a multi-turn absolute encoder.

When you read BCD or binary parallel output, the serial interface will be disabled. You must complete the parallel read cycle (4 bytes) before you can establish the serial interface. In this application, you must complete the read cycle and bring the DR, DE, A1, and A0 inputs to the 5 VDC level before establishing the serial interface.

In the example below, the encoder position at the time of the read is 0249.3556 turns. The step-by-step process that you must follow to read this position is provided below.

- Step 1** Read the four bytes of data as described earlier in this section.
- Step 2** Interpret each byte as follows.

1ST BYTE (LSB)	Position Byte Value	5	6
	BCD Value	0 1 0 1	0 1 1 0
	Terminal Numbers	D7 D6 D5 D4	D3 D2 D1 D0
2ND BYTE	Position Byte Value	3	5
	BCD Value	0 0 1 1	0 1 0 1
	Terminal Numbers	D7 D6 D5 D4	D3 D2 D1 D0

3RD BYTE	Position Byte Value								
	BCD Value	0	1	0	0	1	0	0	1
	Terminal Numbers	D7	D6	D5	D4	D3	D2	D1	D0
4TH BYTE (MSB)	Position Byte Value								
	BCD Value	0	0	0	0	0	0	1	0
	Terminal Numbers	D7	D6	D5	D4	D3	D2	D1	D0

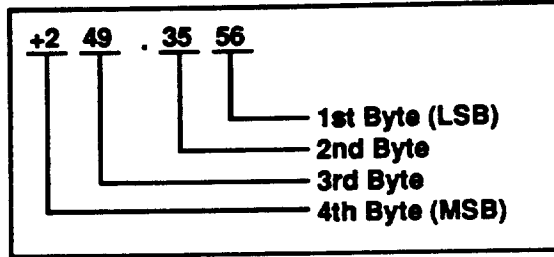

The value above will be frozen until the Data Request input returns to its high or off state. Notice that D4 is used for the sign bit (0 = +, 1 = -). Also, no bits are used for the decimal point. The location of this point is imaginary and should be signified within the device that is reading the encoder data.

Interpreting 8-Bit Binary Output for the -1 Decoder

Turn DIP switch 5 (S5) off to select the binary output format. Refer to Table 4-1 for the multiplication table to establish corresponding data. This example assumes that you are using a multi-turn absolute encoder.

The encoder position at the time of the read is **0249.3556** turns. The step-by-step process that you must follow to read this position is provided below.

Step 1 Read the four bytes of data.

Step 2 Interpret each byte as follows.

1ST BYTE (LSB)	Position Byte Value								
	Binary Value	0	0	1	1	1	0	0	0
	Terminal Numbers	D7	D6	D5	D4	D3	D2	D1	D0
2ND BYTE	Position Byte Value								
	Binary Value	0	0	1	0	0	0	1	1
	Terminal Numbers	D7	D6	D5	D4	D3	D2	D1	D0
3RD BYTE	Position Byte Value								
	Binary Value	0	0	1	1	0	0	0	1
	Terminal Numbers	D7	D6	D5	D4	D3	D2	D1	D0
4TH BYTE (MSB)	Position Byte Value								
	Binary Value	0	0	1	0	0	0	1	1
	Terminal Numbers	D7	D6	D5	D4	D3	D2	D1	D0

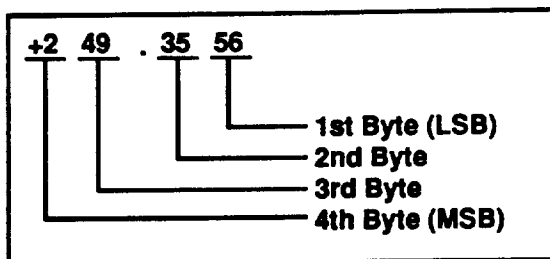

The value above will be frozen until the Data Dequest input returns to its high or off state. Notice that D4 is used for the sign bit (0 = +, 1 = -). Also, no bits are used for the decimal point. The location of this point is imaginary and should be signified within the device that is reading the encoder data.

-1 Decoder 16-Bit Data Output

This section explains the process of reading a position in 16-bit segments. Wire and configure your decoder (DIP switches and jumpers) as described in Chapter 2, Getting Started (-1 Decoder 16-Bit Parallel Interface). Use DIP switch S5 to select the binary (OFF) or BCD (ON) output format. To read a position (two two-byte segments—also referred to as a *word*) from the AR23, refer to Figure 4-4 and follow the steps below.

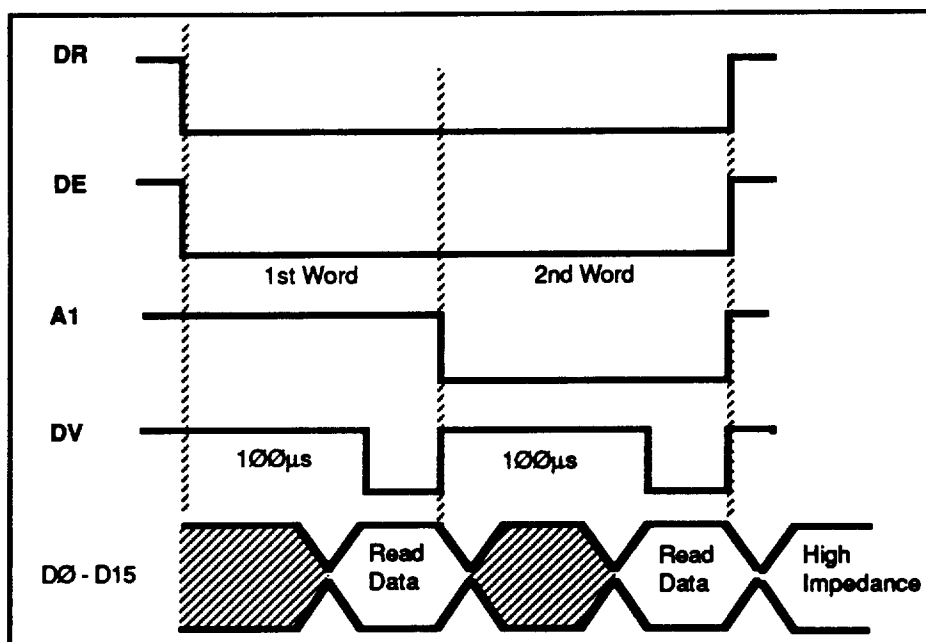

Figure 4-4. Timing—16-Bit Parallel Output (-1 Decoder)

If you are using only one AR23 Encoder, you can tie the Device Enable input low. The Device Enable function controls when the output goes in or out of a high-impedance state. If you multiplex more than one unit, the Device Enable input selects which output the system will read. The Data Request output must remain active during the entire data transfer (all four bytes). A1 selects which word to read. The Data Valid (DV) output provides a signal when the data is stable or ready.

- Step 1** Request the least significant word (LSW) by bringing Address Select A1 high. Ground the Data Request (DR) and Device Enable (DE) outputs.
- Step 2** Wait for the Data Valid (DV) output to go low. *This usually takes approximately 100µs.*
- Step 3** Read the LSW.
- Step 4** Request the most significant word (MSW) by leaving the DR and DE outputs grounded and grounding Address Select A1.
- Step 5** Wait for the Data Valid (DV) output to go low.
- Step 6** Read the MSW.

The three MSBs of the second word contain error code information. Refer to Chapter 7, Maintenance & Troubleshooting for a description of the error codes.

The second word must always be read. This contains not only the error code, but also the direction indication. This word will be frozen as long as the Data Request is active.

If you are using a single-turn encoder, only the first word contains the encoder's actual position. You must read the second word to obtain error codes.

If this interface is with a PLC, use a 16-bit TTL input module with a minimum of two TTL-compatible outputs to control output operation. If you are using an IBM PC, use a TTL-compatible I/O card with 16 inputs and at least two outputs. Compumotor recommends that you use a MetraByte™ parallel interface card (p/n PIO12). For more information, contact MetraByte™ at (617) 880-3000.

Interpreting 16-Bit BCD Output for the -1 Decoder

Prior to implementing a binary output read, you must properly configure the unit. Turn DIP switch 5 (S5) on to select the BCD output format. After the system reads each byte, refer to Tables 4-1 (Binary) and 4-2 (BCD) for multiplication tables to be established for corresponding data. This example assumes that you are using a multi-turn absolute encoder. The 16-bit output is used. The encoder position at the time of the read is **-254.5802** turns. The process to read the position is as follows:

When you read BCD or binary parallel output, the serial interface will be disabled. You must complete the parallel read cycle (2 words) before you can establish the serial interface. In this application, you must complete the read cycle and bring the DR, DE, A1, and A0 inputs to the 5 VDC level before establishing the serial interface.

Step 1 Read both words (MSW and LSW).

Step 2 Interpret each word as follows.

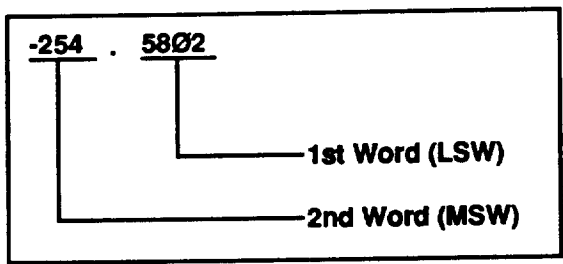
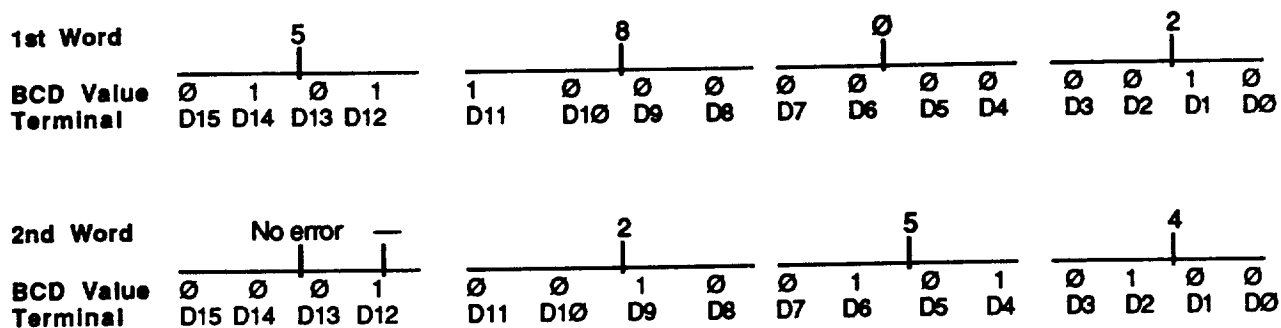

No bits are used for the decimal point. This location is imaginary and should be fixed within the device reading the data.

Interpreting 16-Bit Binary Output for the -1 Decoder

Turn DIP switch 5 (S5) off to select the binary output format. After the system reads each byte, refer to Table 4-1 (Binary) for the multiplication table that corresponds to the data. This example assumes that you are using a multi-turn absolute encoder.

Assuming the encoder position at the time of the read is -254.5802 turns. The process to read the position is as follows:

Step 1 Read both words (MSW and LSW).

Step 2 Interpret each word as follows.

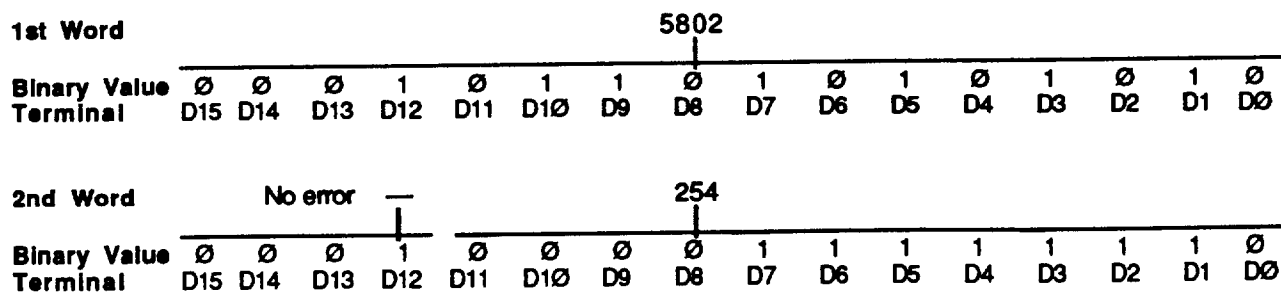

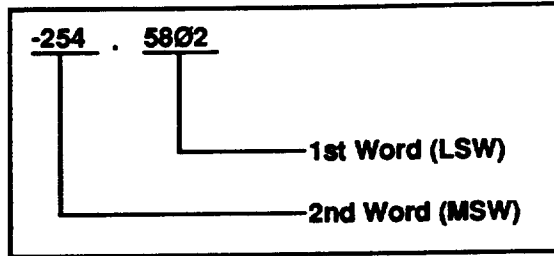

No bits are used for decimal point. This location is imaginary and should be fixed within the device reading the data.

-2 Decoder 16-Bit Data Output

The most popular application of the 16-bit parallel interface is with a programmable controller. The AR23 Encoder needs a TTL compatible 16-bit input module, and a minimum of two TTL-compatible output bits to interface with a programmable controller.

If you are using an IBM PC or an IBM-compatible computer, you must use a TTL-compatible I/O card with 16 inputs and at least 2 outputs. Wire your decoder as described in Chapter 2, Getting Started (-2 Decoder 16-Bit Parallel Interface).

You can configure the output format as either BCD or binary with the SP (Define Data Output) command. SP0 outputs position data in a binary format. SP1 outputs position data in a BCD format. *The default setting is SP1.*

To read a position (two two-byte segments—also referred to as a word) from the AR23 Encoder, refer to Figure 4-5 and follow the steps below.

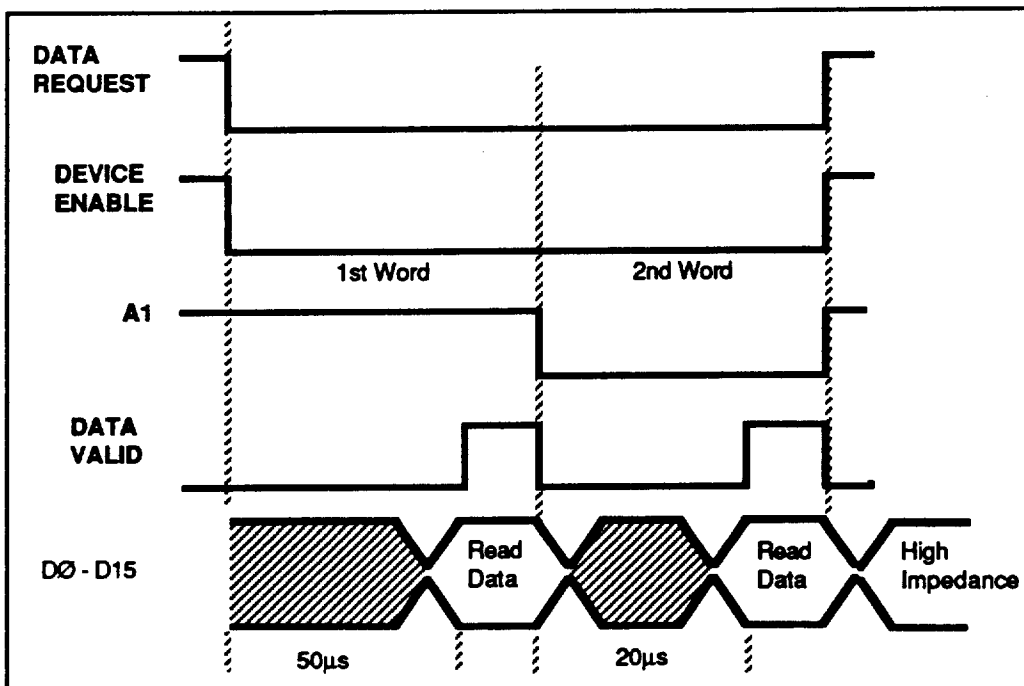

Figure 4-5. Timing—16-Bit Parallel Output (-2 Decoder)

- Step 1** Ground the Device Enable input (pin #9). If your system has only one -2 Decoder, *always* connect the Device Enable input to ground. To select the LSW, bring the WORD SELECT/A1 input (pin #6) high. Ground the Data Request input (pin #8).
- Step 2** Wait for the Data Valid output to go high. *This usually takes approximately 50µs.*
- Step 3** Read the 16-bit output from the -2 Decoder (LSW).
- Step 4** To select the MSW, ground the WORD SELECT/A1 input (pin #6).
- Step 5** Wait for the Data Valid output to go high. *This usually takes approximately 20µs.*
- Step 6** Read the 16-bit output from the -2 Decoder (MSW).
- Step 7** Bring all of the inputs high.

If you do not have the ability to process the Data Valid output line, allow a delay of 100µs between requesting and reading the data port. This will ensure that the data is valid at parallel outputs D0 - D15.

Interpreting 16-Bit Output for the -2 Decoder

To read and interpret BCD and binary output data from this decoder in the 16-bit parallel format, refer to the examples provided earlier in this chapter (*Interpreting 16-Bit BCD Output for the -1 Decoder* and *Interpreting 16-Bit Binary Output for the -1 Decoder*).

When you read BCD or binary parallel output, the serial interface will be disabled. You must complete the parallel read cycle (2 words) before you can establish the serial interface. In this application, you must complete the read cycle and bring the DATA REQUEST, DEVICE ENABLE, and WORD SELECT/A1 high before establishing the serial interface.

-4 Decoder 8-Bit Data Output

This section explains the process of reading a position in 8-bit segments. Wire your decoder as described in Chapter 2, *Getting Started (-4 Decoder 8-Bit Parallel Interface)*. You can configure the output format as either BCD or binary with the SP (Define Data Output) command. SP0 outputs position data in a binary format. SP1 outputs position data in a BCD format. *The default setting is SP1.* To read a position (4 bytes) from the AR23 Encoder, refer to Figure 4-6 and follow the steps below.

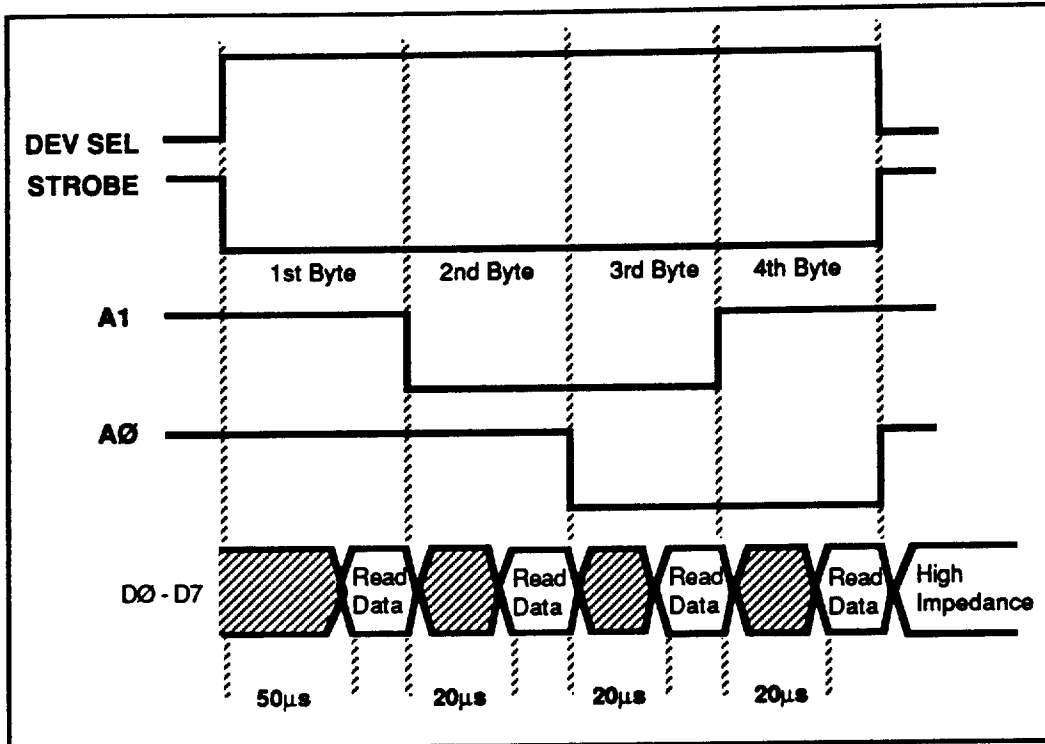

Figure 4-6. Timing—8-Bit Parallel Output (-4 Decoder)

- Step 1** Bring the Device Select input (pin #5) high. If your system has only one -4 Decoder, the Device Select input can remain high at all times. To select the LSB, bring the A1 SEL (pin #4) and A0 SEL (pin #3) inputs high.
- Step 2** Ground the Strobe input (pin #6). The -4 Decoder will process the parallel data output. *The LSB will be valid after 50µs.*
- Step 3** Read the 8-bit output from the -4 Decoder (LSB).
- Step 4** To select the second LSB, ground the A1 input (pin #4) and leave the A0 (pin #3) input high. *The second LSB will be valid after 20µs.*
- Step 5** Read the 8-bit output from the -4 Decoder (second LSB).
- Step 6** To select the second MSB, ground the A0 input (pin #3) and leave the A1 input (pin #4) grounded. *The second MSB will be valid after 20µs.*
- Step 7** Read the 8-bit output from the -4 Decoder (second MSB).
- Step 8** To select the MSB, ground the A0 input (pin #3) and bring the A1 input (pin #4) high. *The second MSB will be valid after 20µs.*
- Step 9** Read the 8-bit output from the -4 Decoder (MSB).
- Step 10** Bring all of the inputs high.

Step 11

If you are using more than one AR23 Encoder, ground the DEV SEL input so you can read output data from other -4 Decoders. The DEV SEL input must be high to allow you to read data.

Interpreting 8-Bit Output for the -4 Decoder

To read and interpret BCD and binary output data from this decoder in the 8-bit parallel format, refer to the examples provided earlier in this chapter (*Interpreting 8-Bit BCD Output for the -1 Decoder* and *Interpreting 8-Bit Binary Output for the -1 Decoder*).

When you read BCD or binary parallel output, the serial interface will be disabled. You must complete the parallel read cycle (4 bytes) before you can establish the serial interface. In this application, you must complete the read cycle and ground the DEVICE SELECT low and bring the STROBE, A0, and A1 inputs high before establishing the serial interface.

Host Computer Operation

If you use the AR23 encoder with a host computer, two interface options are available (depending upon the decoder that you use). The -1 Decoder provides a DIP switch selectable interface for either RS-232C or RS-422/485. The -2 Decoder provides an RS-232C serial link. The -4 Decoder provides an RS-422/485 serial link.

Serial Interface Considerations

This section presents the advantages and disadvantages associated with serial communications.

Advantages

- Wiring required is minimal (usually from 3 - 5 wires).
- If you use RS-422/485, the length of wire from decoder box can be up to 4,000 feet. If you use RS-232C, length of wire can be up to 50 feet.
- Greater capabilities available with status commands.
- Cable is much easier to shield for reliable transmission.
- Simple wiring implementation required for multiple unit connection.

Disadvantage

- Transfer of data is limited. Only one bit can be transmitted every 100 microseconds.

Operating the Serial Interface

The host must be a *dumb terminal*, or have software that allows the computer to emulate a *dumb terminal* (e.g., Pro-Comm™). Before proceeding, enable the host computer for the following protocol:

- Baud Rate: 9,600
- Data Bits: 8
- Start/Stop Bit(s): 1
- Parity: None

Using Multiple Units on an RS-232C Interface (-1 & -2 Decoders)

If you intend to use more than one decoder (i.e., a daisy chain configuration), verify that each unit is communicating properly (as specified in Chapter 2, Getting Started). Ensure proper communications with each unit *before you configure your daisy chain.*

When you use multiple decoders with a single RS-232C interface, you can include a maximum of four decoders in your daisy chain configuration. *Each decoder configured on the daisy chain must have a unique device address.* You can assign a unique device address with the **SN** (Define Device Address) command. The factory default address assigned to every decoder is \emptyset . Refer to Chapter 5, Software Reference for more information on the **SN** command. This section provides a step-by-step procedure for assigning unique device addresses for your decoders. *Do not attempt to assign device addresses at this time.*

Refer to Figure 4-7 for an example of proper daisy chain wiring. The configuration for proper operation with the -1 and -2 decoder is different. *Check the configuration instructions in Chapter 2, Getting Started and complete the steps provided below before wiring the daisy chain to ensure that your system is properly configured.*

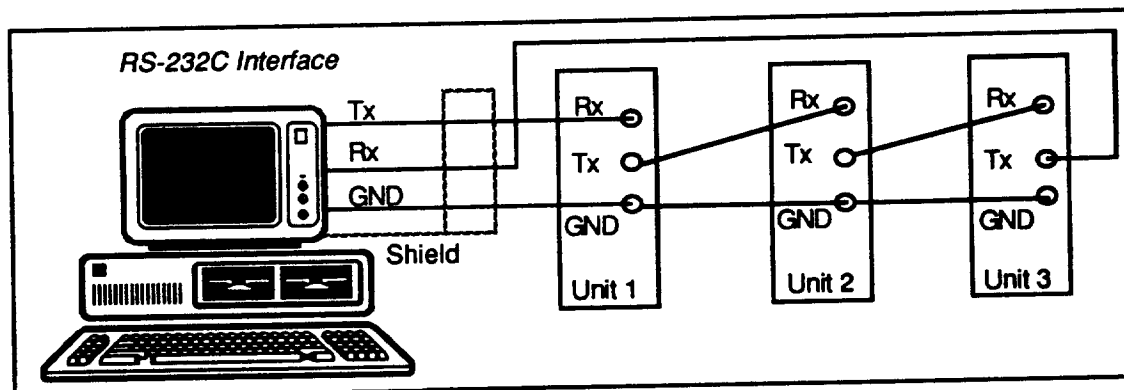

Figure 4-7. RS-232C Daisy Chain Configuration

Daisy Chaining Three -1 Decoders

To perform this example, you must have three -1 decoders. You will wire the units to the single RS-232C interface one at a time to assign unique device addresses for each unit. At the conclusion of this procedure, you will be able to complete the daisy chain configuration.

Step 1

After verifying that each decoder is functioning properly, wire one of the units to the host computer (as per the instructions in Chapter 2, Getting Started) apply power to the all of the units. Enter the following command on your keyboard to the decoder box.

\emptyset SN1

This command changes the device address of this unit to 1.

Step 2 To save this unique address setting to non-volatile memory, enter the following command:

1SS

This unit now has a unique device of **1**. Remove power from the system. Disconnect this unit from the RS-232C interface and wire another one of the units to the interface. Re-apply power.

Step 3 To assign a unique device address to this unit, enter the following command:

ØSN2

This command changes the device address of this unit to **2**.

Step 4 To save this unique address setting to non-volatile memory, enter the following command:

2SS

This unit now has a unique device of **2**. **Remove power from the system.** Disconnect the unit from the RS-232C interface.

At this point, all three of the decoders have a unique device address (Ø, 1, and 2—the decoder you did not change maintains the default address setting of Ø).

Step 5 Refer to Figure 4-7 and wire the daisy chain configuration as shown.

Step 6 Apply power to the three decoders and the computer/terminal. Press the space bar on your keyboard. If the cursor on the screen moves, you are receiving an echo. This indicates that the RS-232C communication link is working properly (from computer/terminal to decoder and from decoder back to computer/terminal). If your cursor does not move when you press the space key, check your wiring connections (refer to Figure 4-7 and repeat this step. If the problem persists, refer to Chapter 7, Maintenance & Troubleshooting.

Step 7 After you have successfully received an echo, enter the following commands (you will receive a response after each command):

ØPR

1PR

2PR

The **PR** (Position Report) command provides a position report. You should receive a position report for each decoder with these commands. If you do not receive the position reports, check your wiring.

Step 8 Manually move the encoder shaft position of the encoder with the unique device address of \emptyset . To see the change in position, type the following command:

\emptyset PR

The position report for this unit's position should differ from the position report you received for this unit in Step 7.

Step 9 Manually move the encoder shaft position of the encoder with the unique device address of 1. To see the change in position, type the following command:

1PR

The position report for this unit's position should differ from the position report you received for this unit in Step 7.

Step 10 Manually move the encoder shaft position of the encoder with the unique device address of 2. To see the change in position, type the following command:

2PR

The position report for this unit's position should differ from the position report you received for this unit in Step 7.

The successful completion of these steps verify that all of the decoders configured on your daisy chain are operating properly. If you encounter problems, check your wiring and try this procedure again (from Step 1), or refer to Chapter 7, Maintenance & Troubleshooting.

Using Multiple Units on an RS-422/485 Interface (-1 & -4 Decoders)

If you intend to use more than one decoder (i.e., a multi-drop configuration), verify that each unit is communicating properly (as specified in Chapter 2, Getting Started). Ensure proper communications with each unit *before you configure your multi-drop system*.

When you use multiple units with the RS-422/485 interface, you can multi-drop up to 16 units to one host serial port. *Each decoder wired on a multi-drop configuration must have a unique device address.* You can assign a unique device address with the SN (Define Device Address) command. The factory default address assigned to every decoder is \emptyset . Refer to Chapter 5, Software Reference for more information on the SN command. This section provides a step-by-step procedure for assigning unique device addresses for your decoders. *Do not attempt to assign device addresses at this time.*

Refer to Figure 4-8 for an example of proper multi-drop wiring. The configuration for proper operation with the -1 and -4 decoder is different. *Check the configuration instructions in Chapter 2, Getting Started and complete the steps provided below before wiring the multi-drop configuration to ensure that your system is properly configured.*

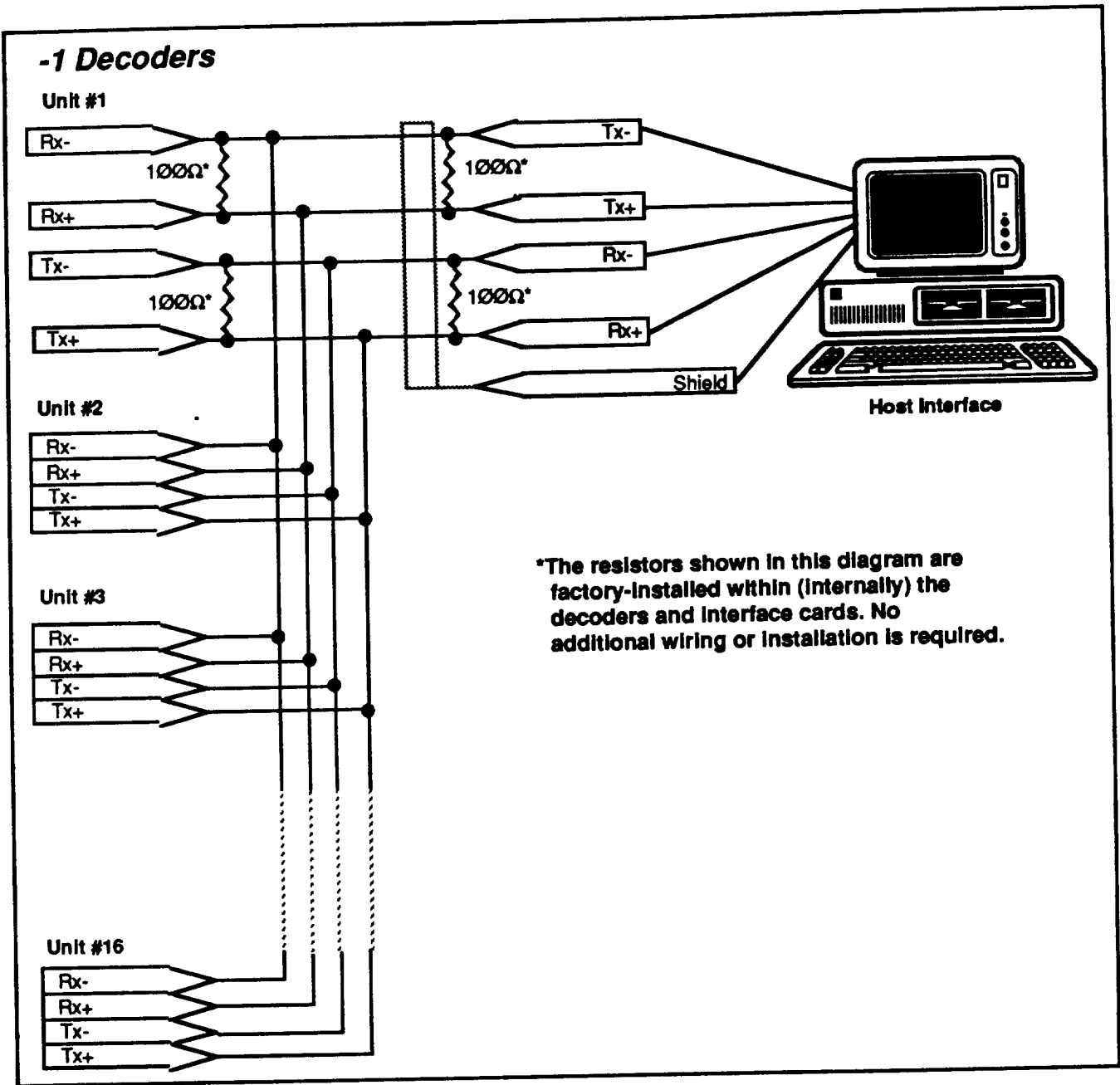

Figure 4-8. AR23 Multi-Drop Wiring

**Multi-Dropping
Three -1
Decoders**

To perform this example, you must have three -1 decoders. You will wire the units to the single RS-422/485 interface one at a time to assign unique device addresses for each unit. At the conclusion of this procedure, you will be able to complete the multi-drop configuration.

Step 1 After verifying that each decoder is functioning properly, wire one of the units to the host computer (as per the instructions in Chapter 2, Getting Started) apply power to the all of the units. Enter the following command on your keyboard to the decoder box.

ØSN1

This command changes the device address of this unit to 1.

Step 2 To save this unique address setting to non-volatile memory, enter the following command:

1SS

This unit now has a unique device of 1. Remove power from the system. Disconnect this unit from the RS-422/485 interface and wire another one of the units to the interface. Re-apply power.

Step 3 To assign a unique device address to this unit, enter the following command:

ØSN2

This command changes the device address of this unit to 2.

Step 4 To save this unique address setting to non-volatile memory, enter the following command:

2SS

This unit now has a unique device of 2. **Remove power from the system.** Disconnect the unit from the RS-422/485 interface.

At this point, all three of the decoders have a unique device address (Ø, 1, and 2—the decoder you did not change maintains the default address setting of Ø).

Step 5 Refer to Figure 4-8 and wire the multi-drop configuration as shown.

Step 6 Apply power to the three decoders and the computer/terminal.

Step 7 After you have successfully received an echo, enter the following commands (you will receive a response after each command):

ØPR

1PR

2PR

The PR (Position Report) command provides a position report. You should receive a position report for each decoder with these commands. If you do not receive the position reports, check your wiring.

- Step 8** Manually move the encoder shaft position of the encoder with the unique device address of \emptyset . To see the change in position, type the following command:

\emptyset PR

The position report for this unit's position should differ from the position report you received for this unit in Step 7.

- Step 9** Manually move the encoder shaft position of the encoder with the unique device address of 1. To see the change in position, type the following command:

1PR

The position report for this unit's position should differ from the position report you received for this unit in Step 7.

- Step 10** Manually move the encoder shaft position of the encoder with the unique device address of 2. To see the change in position, type the following command:

2PR

The position report for this unit's position should differ from the position report you received for this unit in Step 7.

The successful completion of these steps verify that all of the decoders configured on your multi-drop configuration are operating properly. If you encounter problems, check your wiring and try this procedure again (from Step 1), or refer to Chapter 7, Maintenance & Troubleshooting.

Using Multiple Units in Parallel Output Mode (-1 & -4 Decoders)

If you intend to use more than one decoder in parallel output mode (8-bit or 16-bit), you can *multiplex* the parallel outputs. Multiplexing allows you to share common data and control signals between decoders. This reduces the number of inputs and outputs that your PLC uses. You may multiplex as many units as your PLC can handle. For example, if your PLC has 16 available inputs (Device Enable) and outputs (Data Valid), you can multiplex 16 units. You are limited only by the capability of your PLC.

You can read only one decoder at a time. Each decoder must have its own distinct input and output on the PLC. Refer to your PLC's user guide for specific information on I/O capabilities and programming.

Before you begin to wire your multiplex configuration with **-1 Decoders**, you must remove resistor packs **RNS** and **RN11** from all but one decoder in the multiplex configuration (the last unit). For example, if you multiplex 5 units, you would remove resistor packs **RNS** and **RN11** from units 1-4 and keep them in unit 5. Removing these resistors prevents the output transistors from saturating due to low impedance. Refer to Figure 4-9 for the location of these resistors.

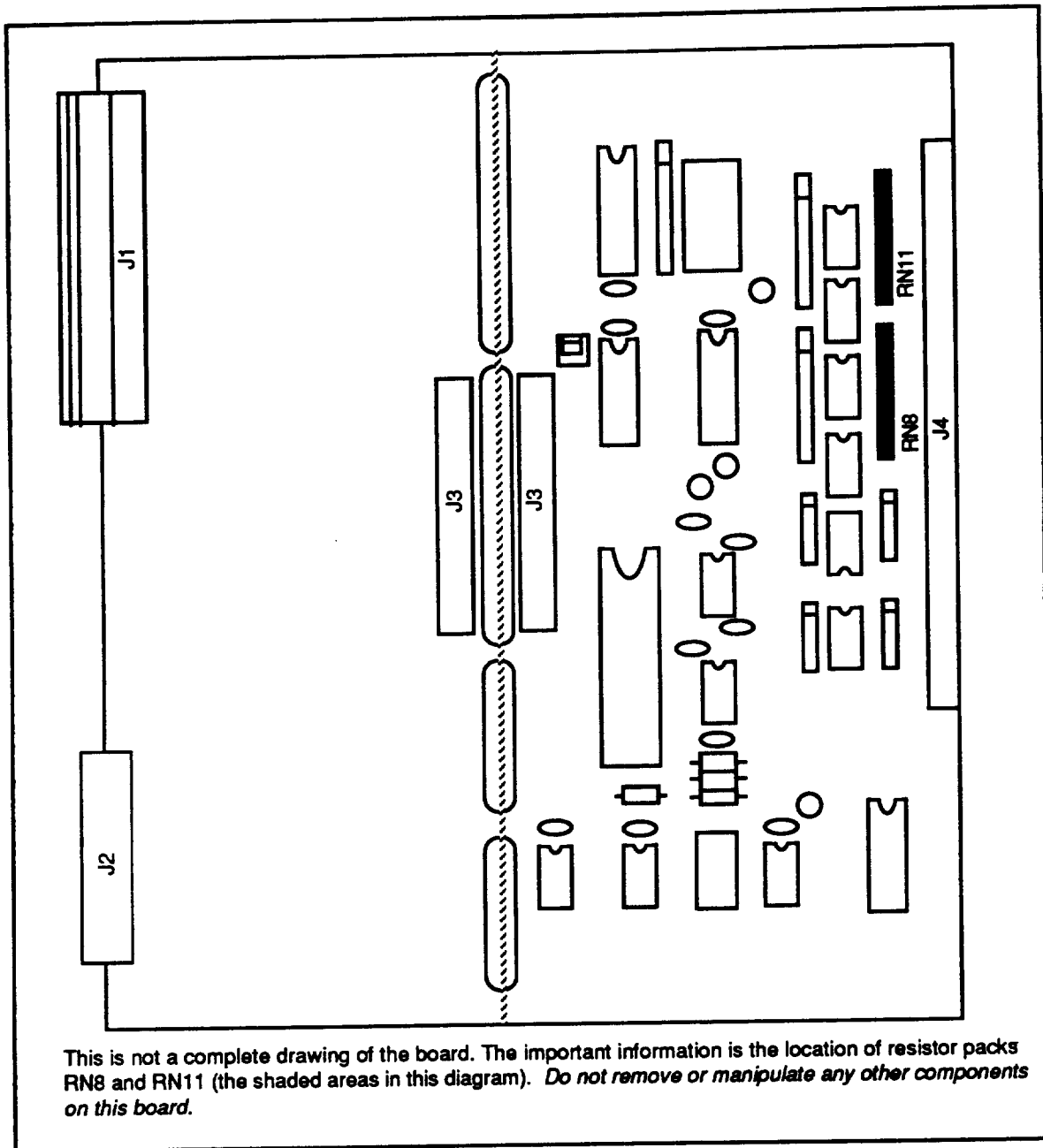

Figure 4-9. Location of RN8 and RN11 Resistor Packs (-1 Decoder Board)

Figure 4-10 illustrates the wiring configuration for -1 Decoder multiplexing. Before wiring the units, be sure that each unit complies with the recommendations previously discussed (distinct I/O on PLC and removal of resistors on all but one unit).

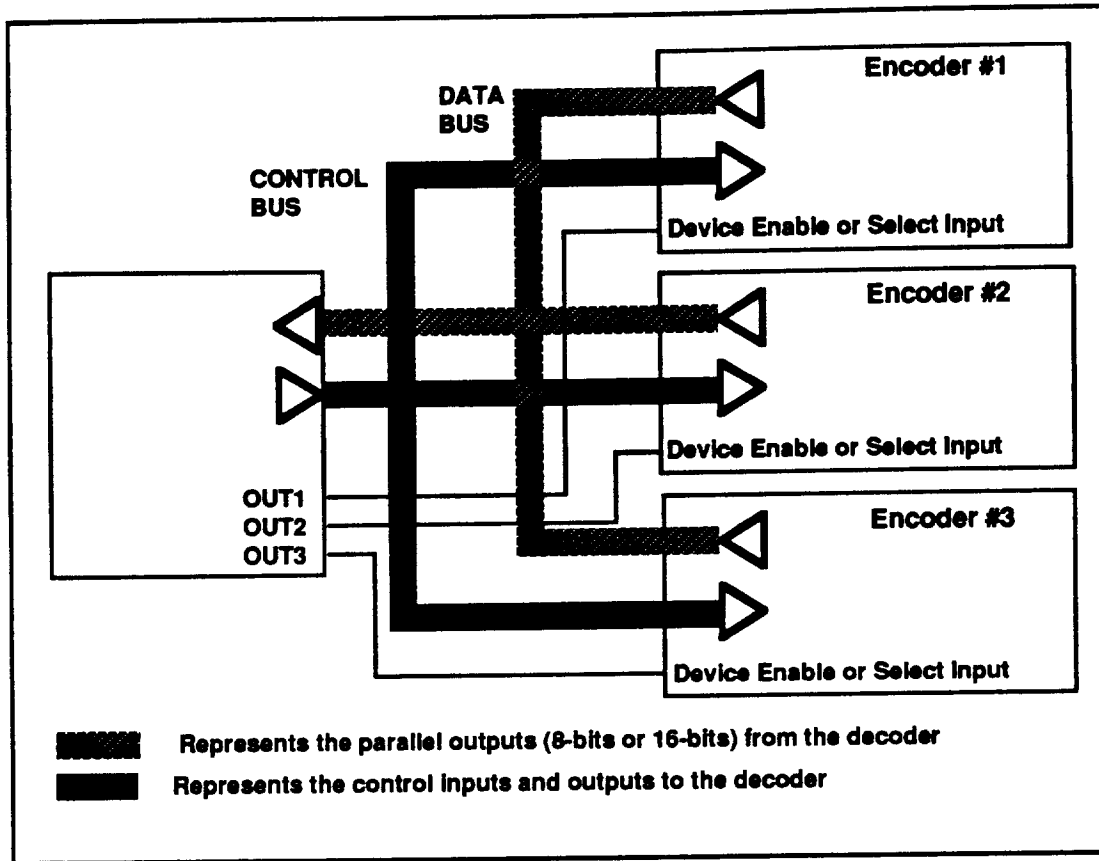

Figure 4-10. Multiplexing Configuration (-1 Decoder)

The -1 and -2 Decoders also have a Data Valid (DV) output. The PLC can handshake with the decoder using the DV output and the Device Enable (DE) input of the decoder. For -4 Decoders, the PLC can have a dwell time of approximately 50µs before reading the data.

Chapter 5. SOFTWARE REFERENCE

Chapter Objectives

The information in this chapter will enable you to:

- Use this chapter as a reference for the function, range, default, and sample use of each command

Command Descriptions

The AR23 allows you to communicate over the serial interface with several software commands.

SO Set-Up		Define Position Offset		Valid Software Version Y
SYNTAX aSONnnnnnnn	UNITS n = offset	RANGE Ø - 255, A	DEFAULT Ø	ATTRIBUTES Immediate Independently Saved
EXECUTION TIME <2 ms		SEE ALSO SS		
RESPONSE TO <a>An IS No Response				

1. Mnemonic Code

This box contains the command's mnemonic code and the command type. The command types are described below.

2. Type

This portion of the box contains the command's type. The four command types are listed below.

Status

Status commands respond (report back) with information.

Set-Up

Setup commands define setup conditions for the application. Setup commands include the following types of commands:

- Homing (Go home acceleration and velocity, etc.)
- Input/Output (Limits, scan time, in-position time, etc.)
- Tuning (Servo or position tracking)
- General (Set switches, return to factory settings, etc.)

Programming

Programming commands affect programming and program flow. For example, trigger, output, all sequence commands, quote, time delays, pause and continue, enable and front-panel, loop and end loop, line feed, carriage return, and backspace.

3. Full Name

This field contains the full command name.

4. Valid Revision Level

This field contains the revision history of the command. It includes the revision of software when the command was added or modified. If the revision level of the software you are using is equal to or greater than the revision level listed in this field, you are using the proper version of the software.

- 5. Syntax** The proper syntax for the command is shown here. The specific parameters associated with the command are also shown. Definitions of the parameters are described below.
- a This indicates that a device address must accompany the command. Only the device specified by this parameter receives and executes the command. If this parameter, or any other parameter appears within brackets <a>, it is optional.
 - n This represents an integer. You may use an integer to specify a variety of values (acceleration, velocity, etc.).
- 6. Units** This field describes what unit of measurement the parameter in the command syntax represents.
- 7. Range** This is the range of valid values that you can specify for n (or any other parameter specified).
- 8. Default** The default setting for the command is shown in this box. A command will perform its function with the default setting if you do not provide a value.
- 9. Attributes** This box indicates if the command is *immediate* or *buffered*. The system executes immediate commands as soon as it receives them. Buffered commands are executed in the order that they are received with other buffered commands. You can store buffered commands in a sequence and save them in permanent memory.
- The lower portion of the box explains how you can save the command.
- Independently Saved
 - Never Saved
- You must enter an **SS** (Save Parameters) command to maintain parameters that are *independently saved*. A command that is *never saved* is never placed in the system's permanent memory.
- 10. Execution Time** The execution time is the span of time that passes from the moment you issue a command to the moment the system begins to execute it.
- 11. See Also** Commands that are related or similar to the command described are listed here.
- 12. Response** A sample status command is given (next to **RESPONSE TO**) and the system response is shown in the adjoining box. *This box will only be provided if the system provides a response to the command. If no response is provided, this box will not be included with the command description.*

Command Listing

AR Status	Automatic Position Report			VALID Software Version Y
SYNTAX aARn	UNITS n = enable or disable	RANGE 0 or 1	DEFAULT 1	ATTRIBUTES Immediate Never Saved
EXECUTION TIME <2 ms		SEE ALSO SS, SP		

Description

This command enables/disables the automatic serial position report. When enabled, the position will be updated 15 times each second. If you enter Ø, you will disable the function. If you enter 1, you will enable the function. You can only use this command while you are in the serial mode (RS-232C & RS-422/485). If your application requires daisy chaining, you must disable the Automatic Report function (position reports do not contain addresses). Once you enable this function, it reports position information continuously until you issue aARØ to disable the function.

Example

Command
ØAR1

Description
Enables automatic position report

PB Status	Binary Position Report			VALID Software Version Y
SYNTAX aPBn	UNITS revolutions	RANGE N/A	DEFAULT N/A	ATTRIBUTES Immediate Never Saved
EXECUTION TIME <2 ms		SEE ALSO PR, P		
RESPONSE TO aPB IS 0000000001100010001000111001				

Description

When you enter this command, the AR23 reports the encoder's current position in binary format. This position will be offset and scaled by programmed parameters. The position report will not appear in ASCII format, therefore, you must read the response as a binary report. If the AR23 is searching for ASCII characters, the unit's response will be in the form of ASCII characters that correspond to the binary pattern.

Example

Command
ØPB

Response
000000000110001000111001
(represents 0.6239 turns)

PR Status	Position Report			VALID Software Version Y
SYNTAX aPR	UNITS N/A	RANGE N/A	DEFAULT N/A	ATTRIBUTES Immediate Never Saved
EXECUTION TIME <2 ms		SEE ALSO PB		
RESPONSE TO aPR IS Ø_25458Ø2				

Description

This command reports the current absolute position. Upon execution, the AR23 provides formatted and scaled encoder position data over the serial port. The encoder's position is reported with seven digits. The last four digits represent the fraction of a revolution that the encoder is located at. The first three digits represent the absolute number of encoder turns. The report is given in one of the following formats, depending on how you set the SP command.

SP Ø Response is in hexadecimal format

SP 1 Response is in decimal format (no decimal point)

SP 2 Response is in decimal format (decimal point automatically inserted)

ExampleCommand

ØPR

Response

Ø_25458Ø2 (Ø = an error code, _ = a space, and the seven-digit number represents the current absolute encoder position). The space will contain a minus sign [-] if you create a position offset (SO command) and the encoder rotates beyond the new zero point in the decreasing counts direction.

RP Status	Report Set-Up Parameters			VALID Software Version Y
SYNTAX aRP	UNITS N/A	RANGE N/A	DEFAULT N/A	ATTRIBUTES Immediate Never Saved
EXECUTION TIME <2 ms		SEE ALSO N/A		

Description

This command reports the current set-up parameters. The report is sent via the serial port in ASCII decimal format only.

Example

Cmd	-4 Response	-2 Response	-1 Response
ØRP	SN=Ø SP=Ø1 SE=Ø1 AR=ØØ SD=ØØ SM=ØØ SO=ØØØØØØØØ SF=Ø1ØØØØ	SN=Ø SP=Ø1 SE=Ø1 AR=ØØ SD=ØØ SO=ØØØØØØØØ SF=Ø1ØØØØ	SN=Ø SP=ØØ SE=Ø1 AR=ØØ SD=ØØ SM=ØØ SO=ØØØØØØØØ SF=Ø1ØØØØ SL=ØØØØØØØØ
<i>These represent default settings</i>			

RV Status	Revision Level			VALID Software Version Y
SYNTAX aRVn	UNITS N/A	RANGE N/A	DEFAULT N/A	ATTRIBUTES Immediate Never Saved
EXECUTION TIME <2 ms		SEE ALSO PR		
RESPONSE TO aRV IS RV 92-9109-01A				

Description

The RV (Revision) command provides the current software revision level. The response is given in the following format: RV 92-9109-01n (n = the level of the revision, the preceding 8-digit number is the part number). The revision level indicates when the software was written. You may want to record this information in your own records for future use. This type of information is especially useful when directing questions about software to Parker Compumotor's Applications Department.

Example

<u>Command</u> ØRV	<u>Description</u> Indicates the software revision level for this unit
-----------------------	---

SD Set-Up	Define Direction			VALID Software Version Y (-2 & -4 Decoders)
SYNTAX aSDn	UNITS n = CW or CCW	RANGE 0 or 1	DEFAULT 0	ATTRIBUTES Immediate Independently Saved
EXECUTION TIME <2 ms		SEE ALSO SS		

Description The SD command is not valid with the -1 Decoder box. This command allows you to define shaft rotation to increase position output. If you enter 0, position output will increase with CCW shaft rotation. If you enter 1, position output will increase with CW rotation. (You can enable and disable this function with the internal DIP switch.)

Example

<u>Command</u>	<u>Description</u>
0SD1	Position output increases with CW rotation

SE Set-Up	Enable Error Checking			VALID Software Version Y
SYNTAX aSDn	UNITS n = enable or disable	RANGE 0 or 1	DEFAULT 1	ATTRIBUTES Immediate Never Saved
EXECUTION TIME <2 ms		SEE ALSO SS		

Description This command enables/disables the error checking function. If you enter 1, you will enable error checking. If you enter 0, you will disable error checking. The error code is the most significant (first) digit of the position report in serial mode, and the two most significant bits (first two) in parallel mode. Four possible error codes may be reported. These error codes are described in Chapter 7, Troubleshooting & Maintenance.

Example

<u>Command</u>	<u>Description</u>
0SE1	Enables error checking

SF Set-Up	Define Scale Factor			VALID Software Version Y
SYNTAX aSFnnnnn	UNITS n = 0.001	RANGE 00001 - 29999	DEFAULT 10000	ATTRIBUTES Immediate Never Saved
EXECUTION TIME <2 ms		SEE ALSO SS		

Description This command scales the encoder position output in desired units. This is multiplied by the present position before a position output is reported. There is an imaginary decimal after the first number.

Example	<u>Command</u>	<u>Description</u>
	ØSFØ5ØØØ	Defines the scale factor as 0.5
	ØSF2ØØØØ	Defines the scale factor as 2.0000

SL Set-Up	Define Output 2 Position			VALID Software Version Y -1 Decoder
SYNTAX aSLnnnnn	UNITS n = 0.01	RANGE 000001 - 99999	DEFAULT 0	ATTRIBUTES Immediate Independently Saved
EXECUTION TIME <2 ms		SEE ALSO SS		

Description The SL command is only available with the -1 Decoder. It has a dead band value of 0.01 of a revolution. This command defines a position where Output 2 is turned on. This command indicates to a remote controller that the AR23 has reached its home position. Output 1 is used in the same manner as the status LED (Output 1 and the status LED will be on if the encoder reaches the absolute zero position). You cannot control Output 1 with the SL command. It has a dead band value of 0.01 of a revolution. *If the encoder cable is not connected, the decoder will interpret the encoder's position as zero (Ø) and illuminate the status LED.*

Example	<u>Command</u>	<u>Description</u>
	ØSL24ØØ1	Defines Output 2 as active at position 240.01. Output 2 will remain active between encoder position 240.0100 and 240.0199.

SM Set-Up	Define Communications: Full or Half Duplex			VALID Software Version Y -4 Decoder
SYNTAX aSMn	UNITS n = full or half duplex	RANGE 0 = full duplex 1 = half duplex	DEFAULT 0	ATTRIBUTES Immediate Independently Saved
EXECUTION TIME <2 ms		SEE ALSO SS		

Description This command is only applicable for RS-422/485 communications. The command defines RS-422/485 communications as full or half duplex. Half duplex is actually RS-485. If you enter 1, you will enable the serial interface as half duplex. If you enter Ø, you will enable the serial interface as full duplex. This command is only valid for the -4 Decoder.

Example

<u>Command</u>	<u>Description</u>
ØSM1	Enables half duplex interface

SN Set-Up	Define Device Address			VALID Software Version Y
SYNTAX aSNn	UNITS n = device address	RANGE 0 to 9, A - F	DEFAULT 0	ATTRIBUTES Immediate Independently Saved
EXECUTION TIME <2 ms		SEE ALSO N/A		

Description This command defines the device address of each unit. Use this command when more than one unit is connected to same serial port. These addresses are valid for daisy chain and multi-drop configurations. The maximum address capability is 16 units (0 - 9, A - F). Only four units may be configured on an RS-232C daisy chain, however, the units may be assigned any valid address (i.e., the addresses do not have to be sequential—1, 2, 3, 4).

Example

<u>Command</u>	<u>Description</u>
ØSN5	Defines new address as 5 (address was previously 0)

SO Set Up	Define Position Offset			VALID Software Version Y
SYNTAX aSONnnnnnn	UNITS n = position offset	RANGE 0 - 255, A	DEFAULT 0	ATTRIBUTES Immediate Independently Saved
EXECUTION TIME <2 ms		SEE ALSO SS		

Description

This command has an imaginary decimal point after the third digit. It allows you to establish an absolute zero point without turning the shaft until position zero is present. The system compares the value that you enter to the actual position before you entered the command. The difference between the two represents the offset. If you enter A after the command, the offset will be reset to 0. The offset value that you enter after ØSO becomes the new encoder position corresponding to the present mechanical encoder position. *The offset value that you enter cannot be greater than the current encoder value or 2,550,000. Values beyond this range will elicit invalid data from the system.*

Example

Command
ØSOØ

Description
Defines present position as zero (0)

SP Set-Up	Define Position Offset			VALID Software Version Y
SYNTAX aSPn	UNITS n = data output format	RANGE 0 (binary/hex), 1 (BCD/decimal), or 2 (enable decimal)	DEFAULT 0	ATTRIBUTES Immediate Independently Saved
EXECUTION TIME <2 ms		SEE ALSO SS		

Description

This command defines the format of position output data. Zero (0) defines the data format to be binary for parallel output and ASCII hexadecimal for serial output. If you enter 1, you will define the data format as BCD for parallel output and ASCII decimal for serial output. If you enter 2, the decimal point will be enabled at the fourth place from right. *If you are using this option with a -1 Decoder, you must turn DIP switch 5 off.* The SP2 mode is only valid for -1 and -2 Decoders. If you are reading from the parallel output (BCD or binary), set this command to its factory default setting (SP2). The set-up should be performed with DIP switch 3.

Example

Command
ØSPØ

Description
Enables serial output format as ASCII hexadecimal

SS Set-Up	Save Parameters			VALID Software Version Y
SYNTAX aSS	UNITS N/A	RANGE N/A	DEFAULT N/A	ATTRIBUTES Immediate Never Saved
EXECUTION TIME <2 ms		SEE ALSO N/A		

Description Saves all currently defined set-up parameters in non-volatile memory. All commands previously entered will be lost if you do not execute this command.

Example

<u>Command</u>	<u>Description</u>
ØSS	Saves all current set-up parameters

Z Set-Up	Software Reset			VALID Software Version Y
SYNTAX Z	UNITS N/A	RANGE N/A	DEFAULT N/A	ATTRIBUTES Immediate Never Saved
EXECUTION TIME <2 ms		SEE ALSO N/A		

Description The Z (Reset) command is equivalent to cycling power to the decoder. This command returns all internal settings to their default values, unless they were modified and saved with the SS command. This command does not require a device address.

Example

<u>Command</u>	<u>Description</u>
Z	Resets any and all decoders on the system

Chapter 6. HARDWARE REFERENCE

Chapter Objectives

The information in this chapter will enable you to:

- Use this chapter as a quick-reference tool for most system specifications (dimensions & performance)
- Use this chapter as a quick-reference tool for switch settings and proper I/O connections

AR23 System Specifications

This section provides pertinent technical data for the AR23 Encoder.

Mechanical

Resolution	1,024 or 16,384 positions/rev. factory configured
Range	Up to 8,388,608 discrete positions for 512 turns
Accuracy	±0.0002 rev. (5.3 arc minutes)
Repeatability	Less than 0.000061 rev.
Inertia	0.03 oz-in ² (0.387 gm-cm ²)
Friction Torque	1.5 oz-in (.0208 gm-cm)
Maximum Speed	1,000 RPM at full resolution
Slew Speed	5,000 RPM
Housing Material	Aluminum anodized
Shaft Material	#303 stainless steel
Disk Material	Metal
Bearing Rating	ABEC 5
Shaft Loading	<ul style="list-style-type: none"> • Radial 35 lbs • Axial 40 lbs
Seal Type	Fluorocarbon
Housing Weight	1.0 lbs (0.45 Kg)

Electrical

Input Power	-2, -4 Decoder box: 4.8VDC to 5.25VDC, 500 mA/per unit -1 Decoder box: 120VAC, ±10 %, 0.5 A, 50/60 Hz
--------------------	--

Parallel Output	TTL compatible 8 or 16 bits Binary or BCD 20 feet maximum transmission length from decoder box (Use 18-gauge wire for maximum length)
Serial Output	RS-232C or RS-422/485 4,000 feet maximum transmission length for RS-422/485 from decoder box 50 feet maximum transmission length for RS-232C from decoder box
Serial Protocol	<ul style="list-style-type: none">• 9,600 baud• 8 data bits• 1 stop bit• no parity
Update Rate	2 milliseconds
Cable Length	10 feet standard from the encoder head to the decoder box 50 feet maximum (Use 22-gauge wire for maximum length)
Interconnect	Screw terminals, #30 to #14 gauge wire

Environment

Operating Temperature	Encoder/Decoder: 32°F to 122°F (0°C to 50°C)
Storage Temperature	-22°F to 185°F (-30°C to 85°C)
Humidity	0 to 95% (Non-Condensing)

-1 Decoder Box Pin Out

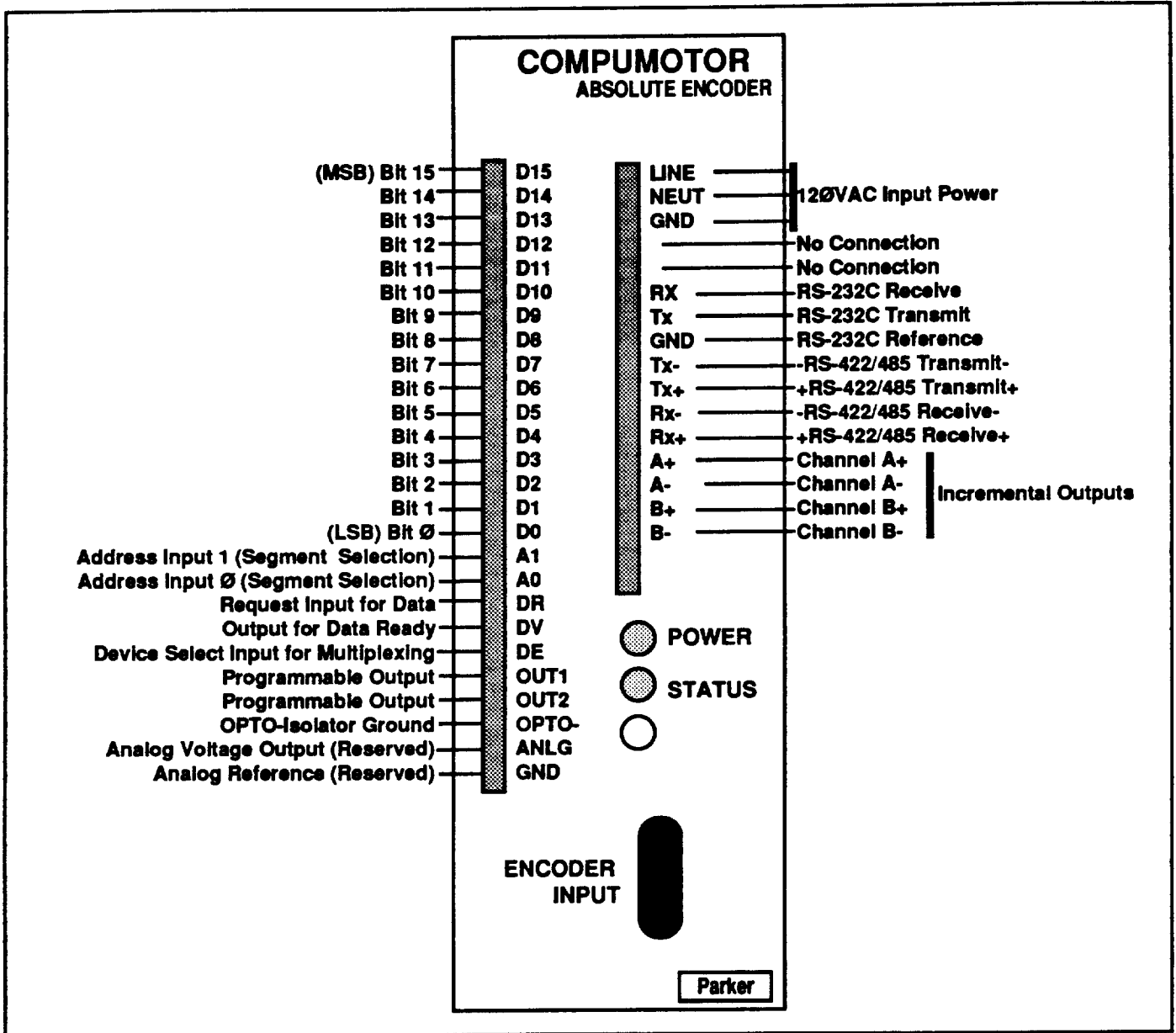

Figure 6-1. -1 Decoder Box Pin Out

-2 Decoder Box Pin Out

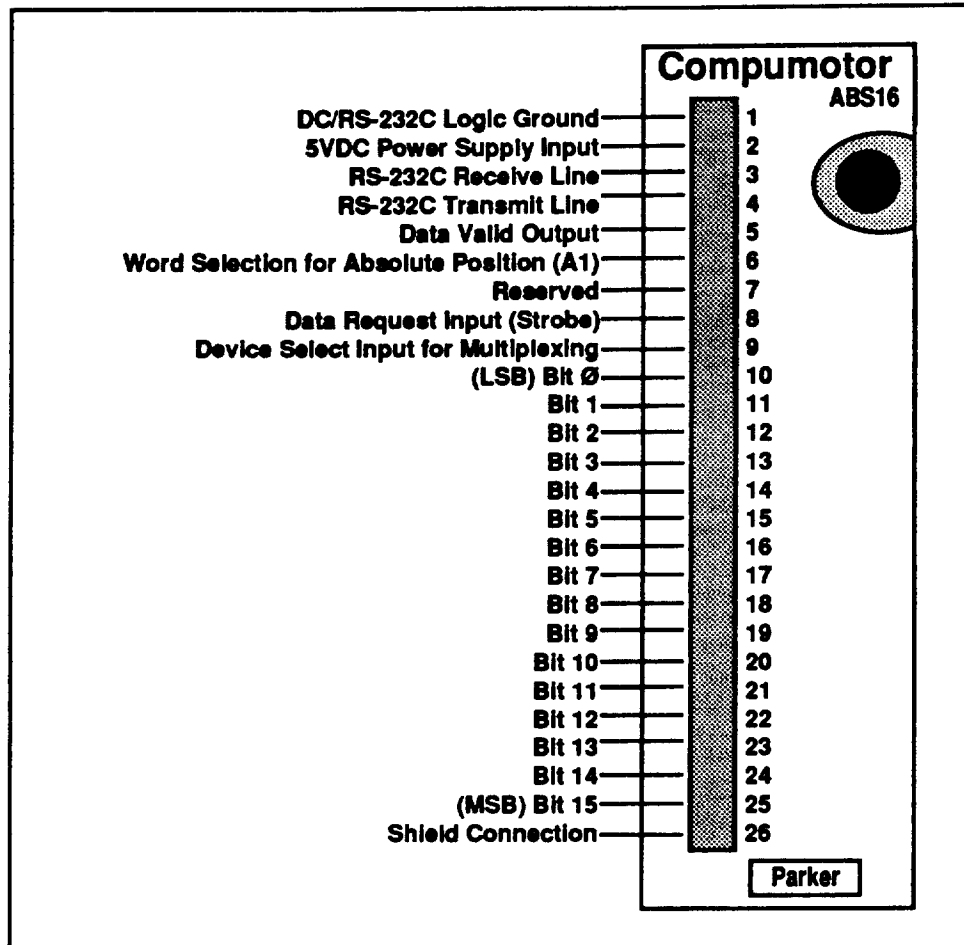

Figure 6-2. -2 Decoder Box Pin Out

-4 Decoder Box Pin Out

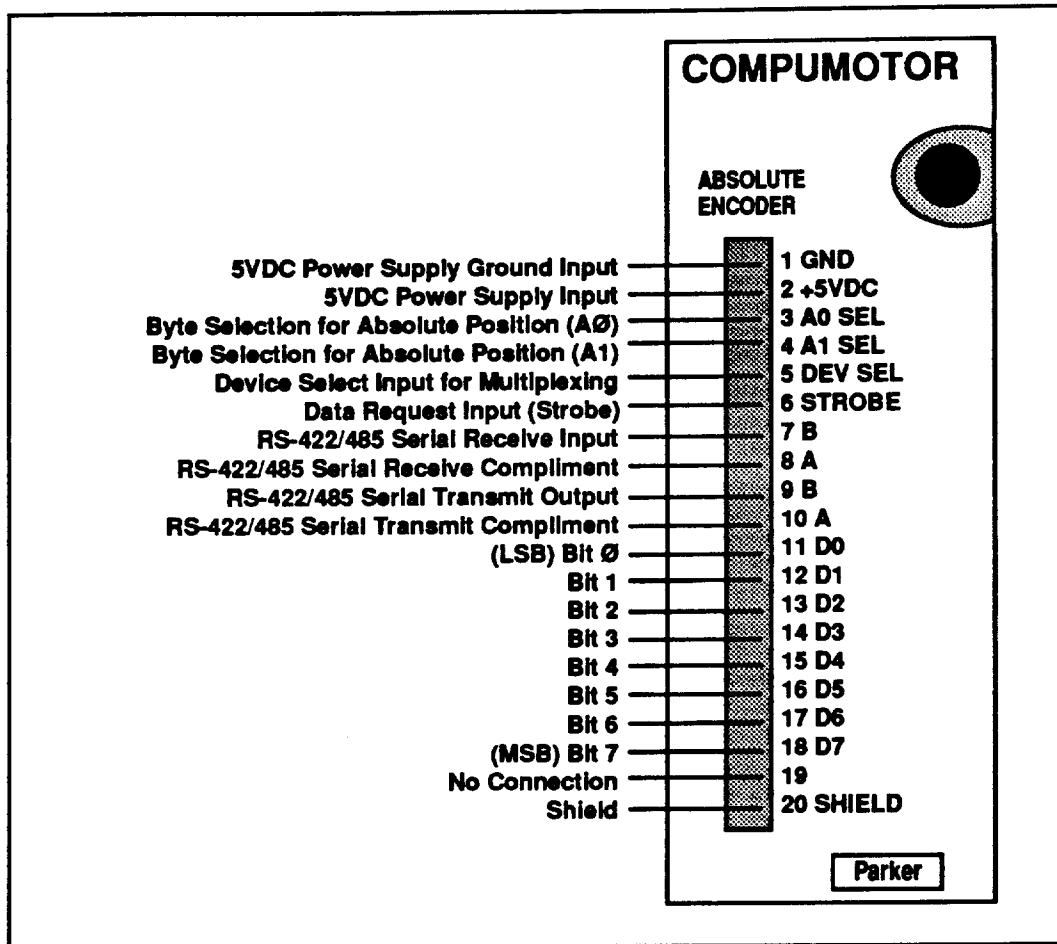

Figure 6-3. -4 Decoder Box Pin Out

Decoder Box Dimensions

-1 Decoder

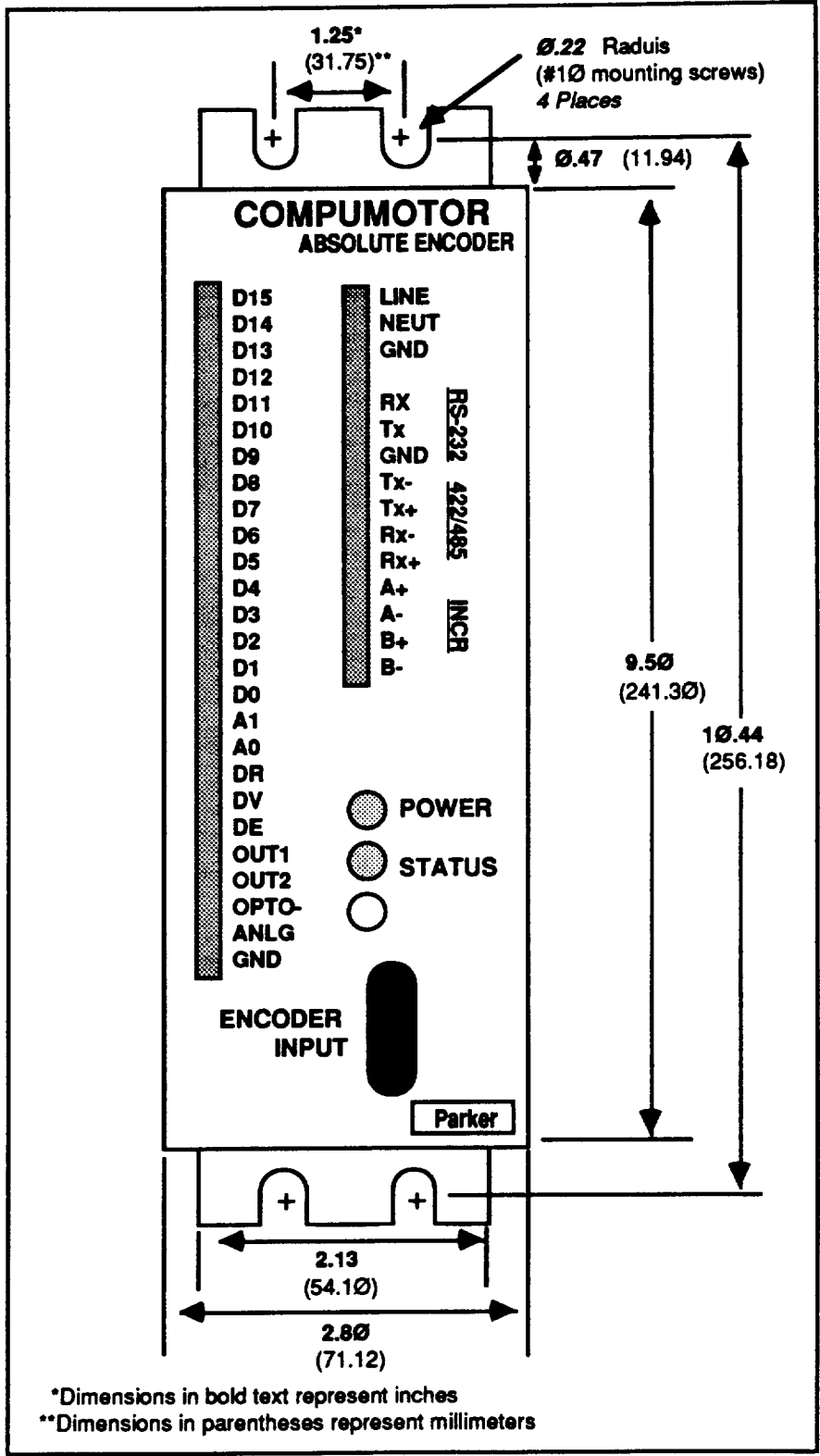

Figure 6-4. -1 Decoder Box Dimensions (Minimum Width Mounting)

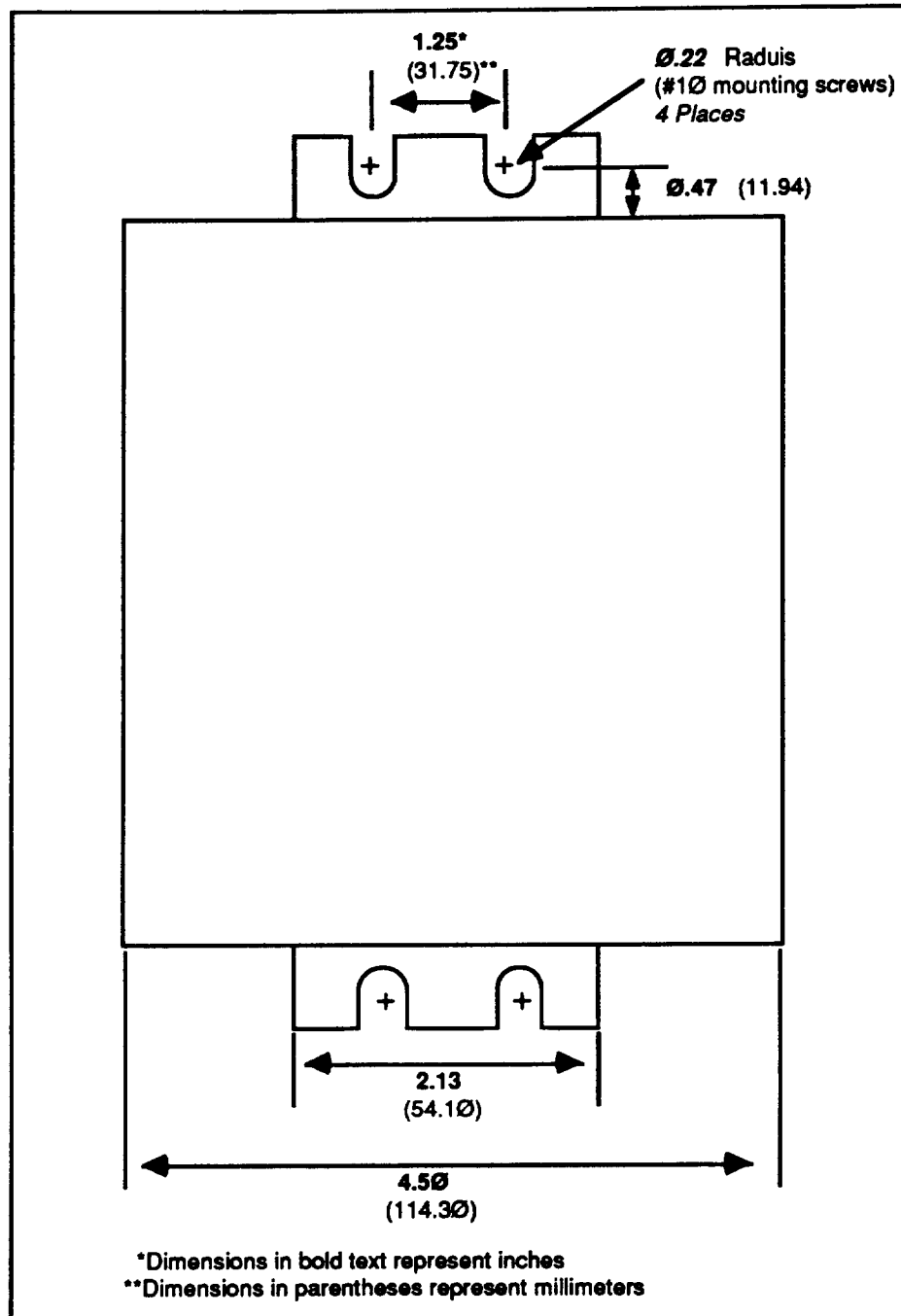

Figure 6-5. -1 Decoder Box Dimensions (Minimum Depth Mounting)

-2 Decoder

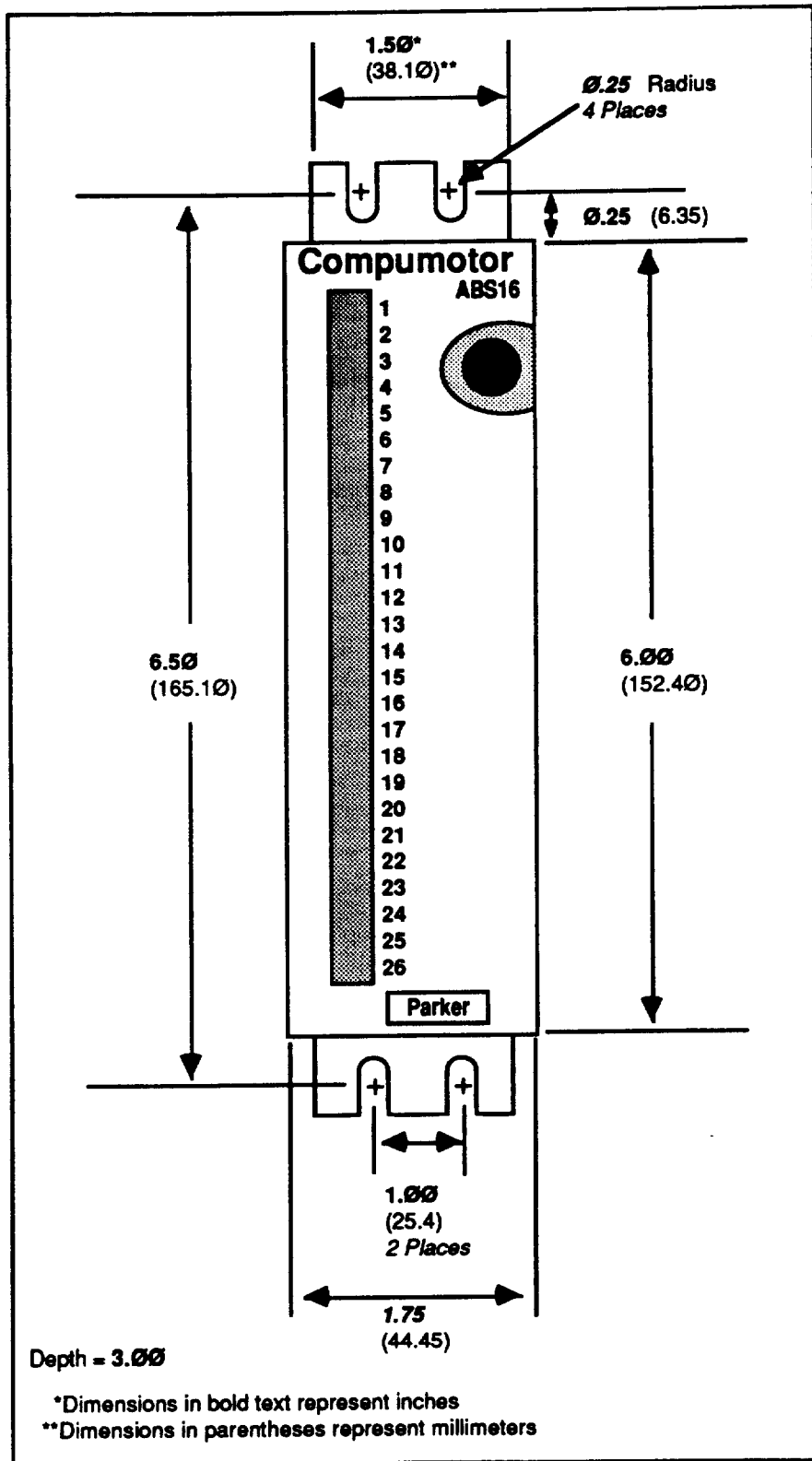

Figure 6-6. -2 Decoder Box Dimensions

-4 Decoder

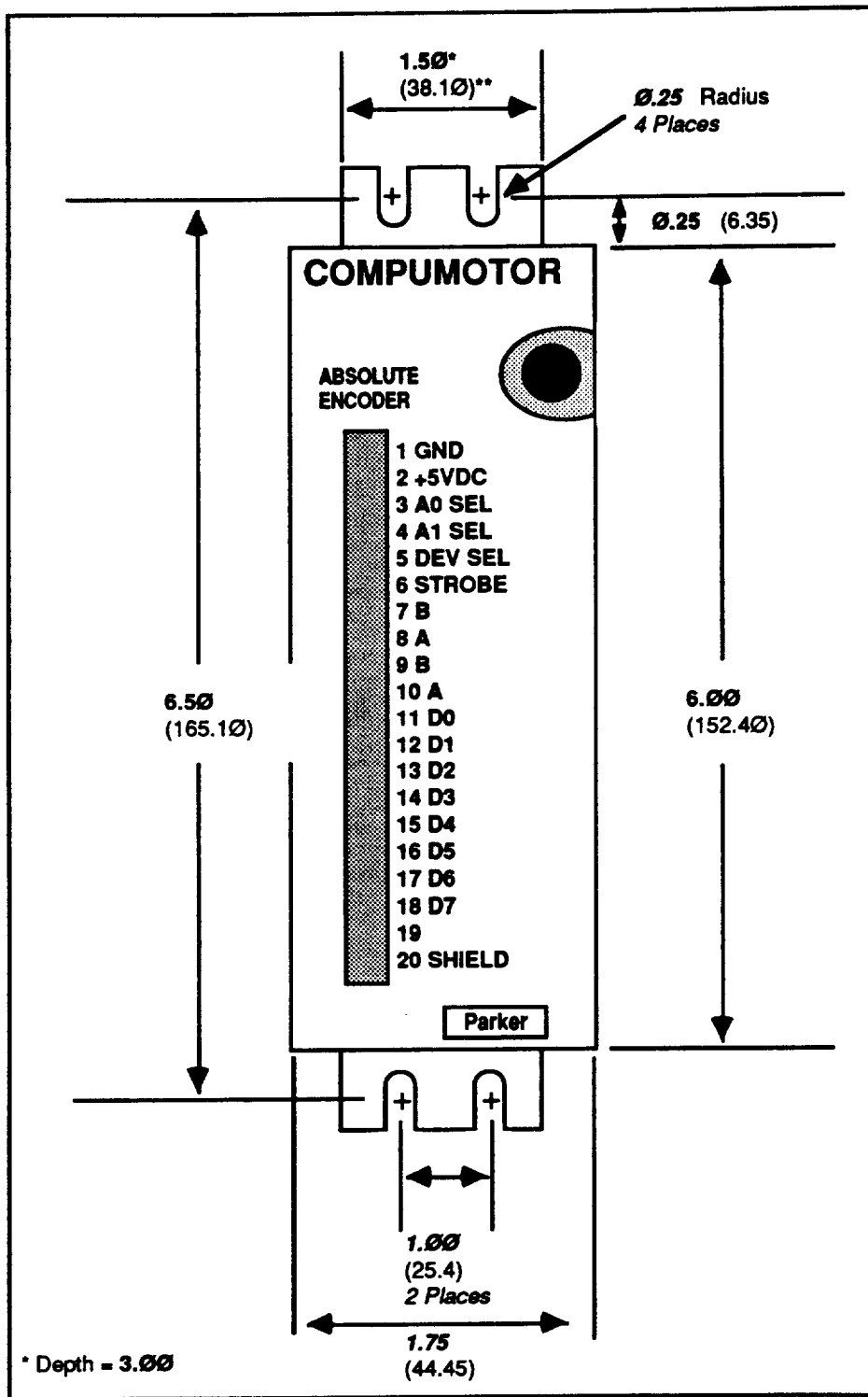

Figure 6-7. -4 Decoder Box Dimensions

Decoder Schematics

-1 Decoder

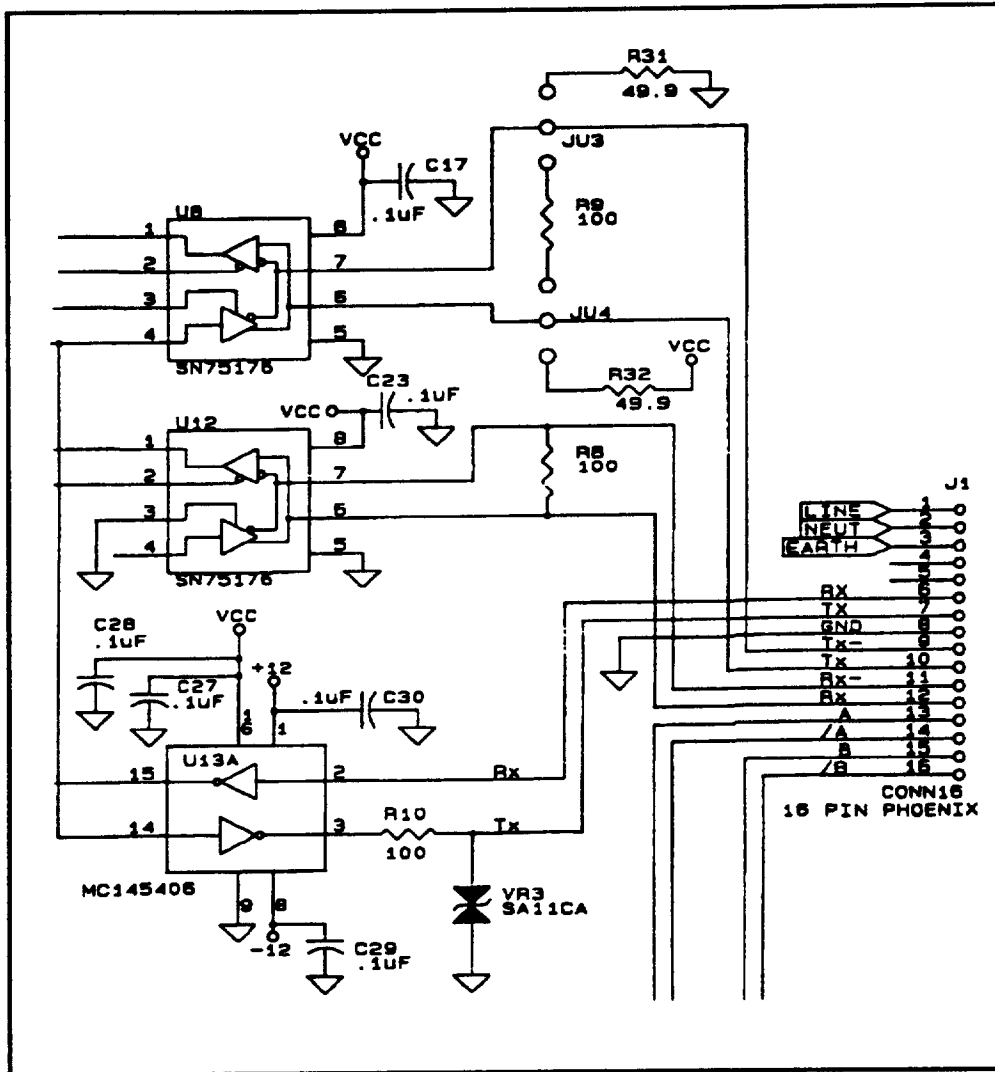

Figure 6-8. Serial Interface (-1 Decoder)

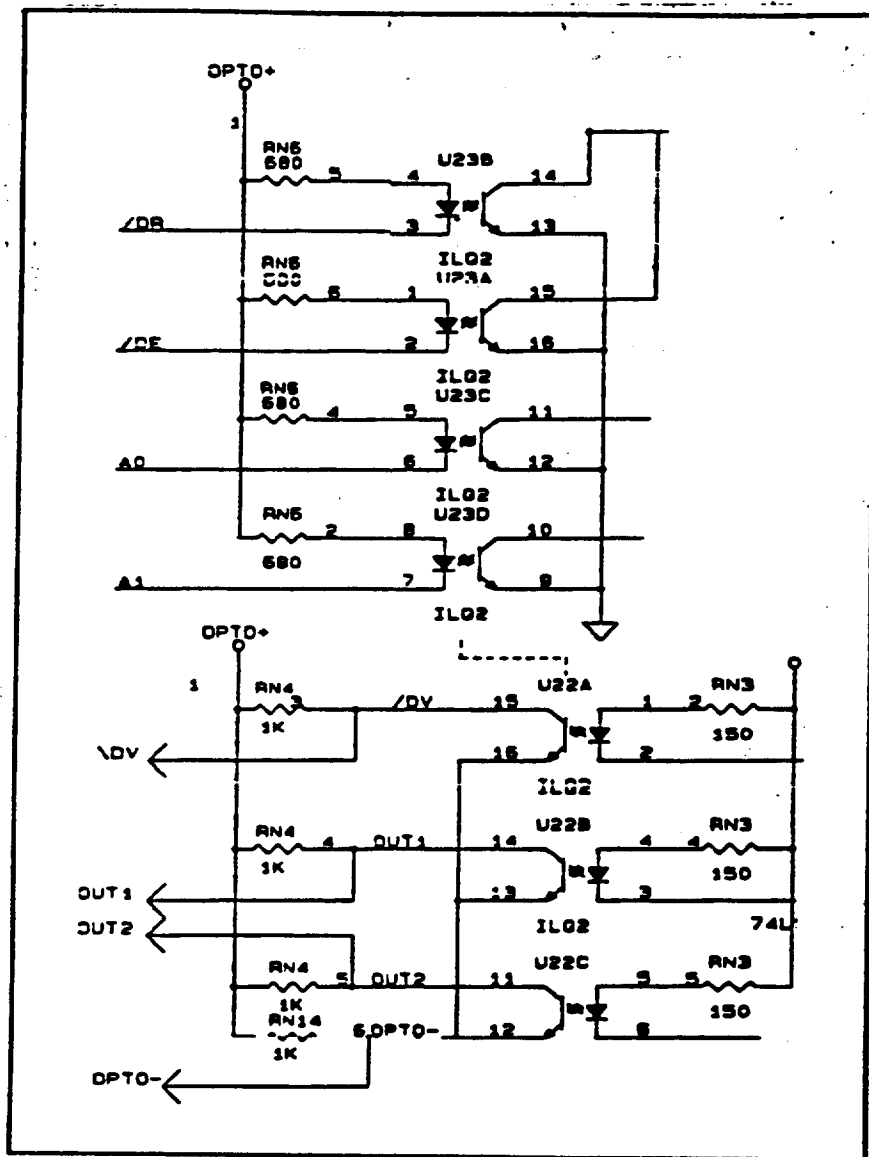

Figure 6-9. Parallel Control Inputs (-1 Decoder)

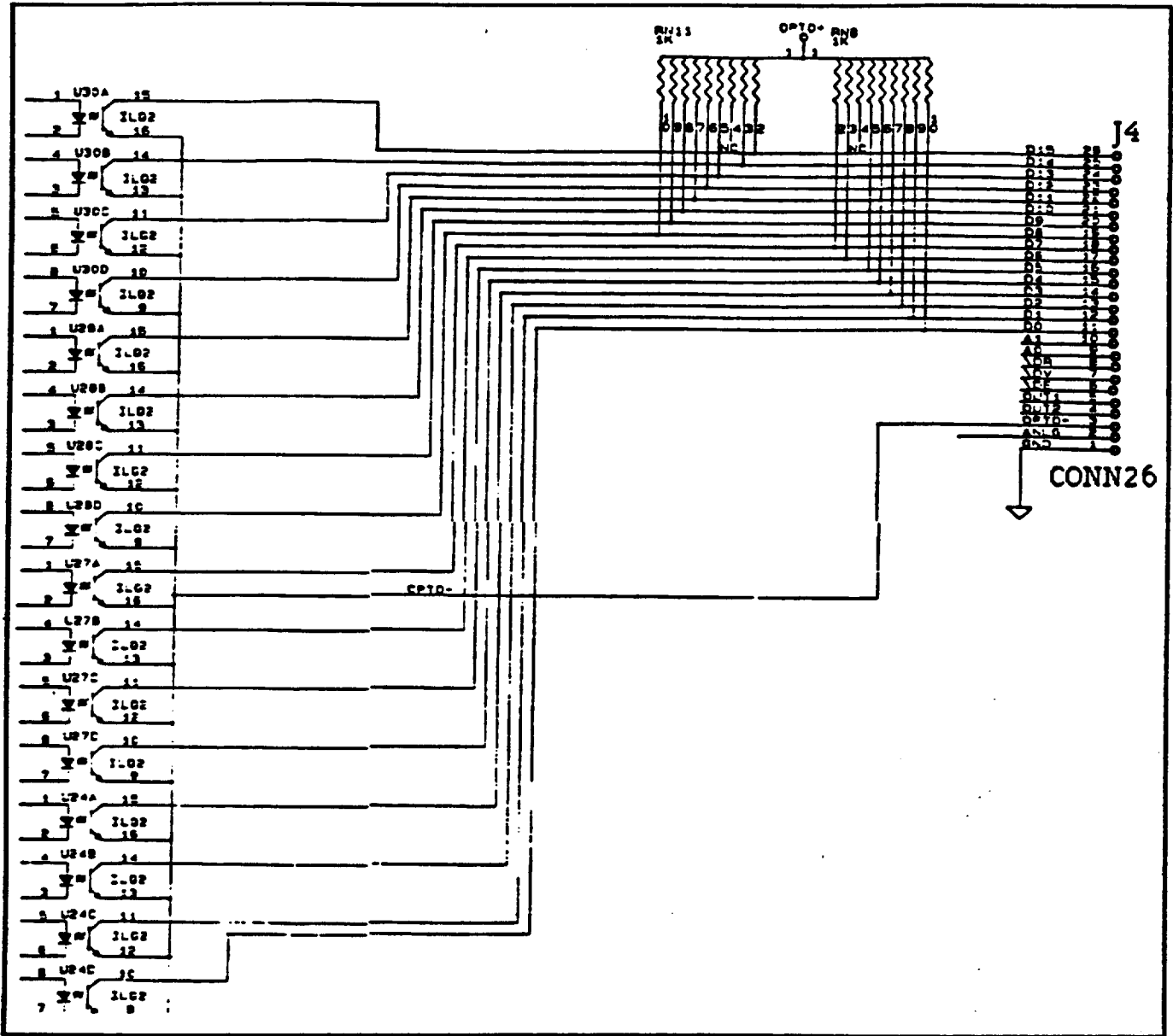

Figure 6-10. Parallel Outputs (-1 Decoder)

-2 Decoder

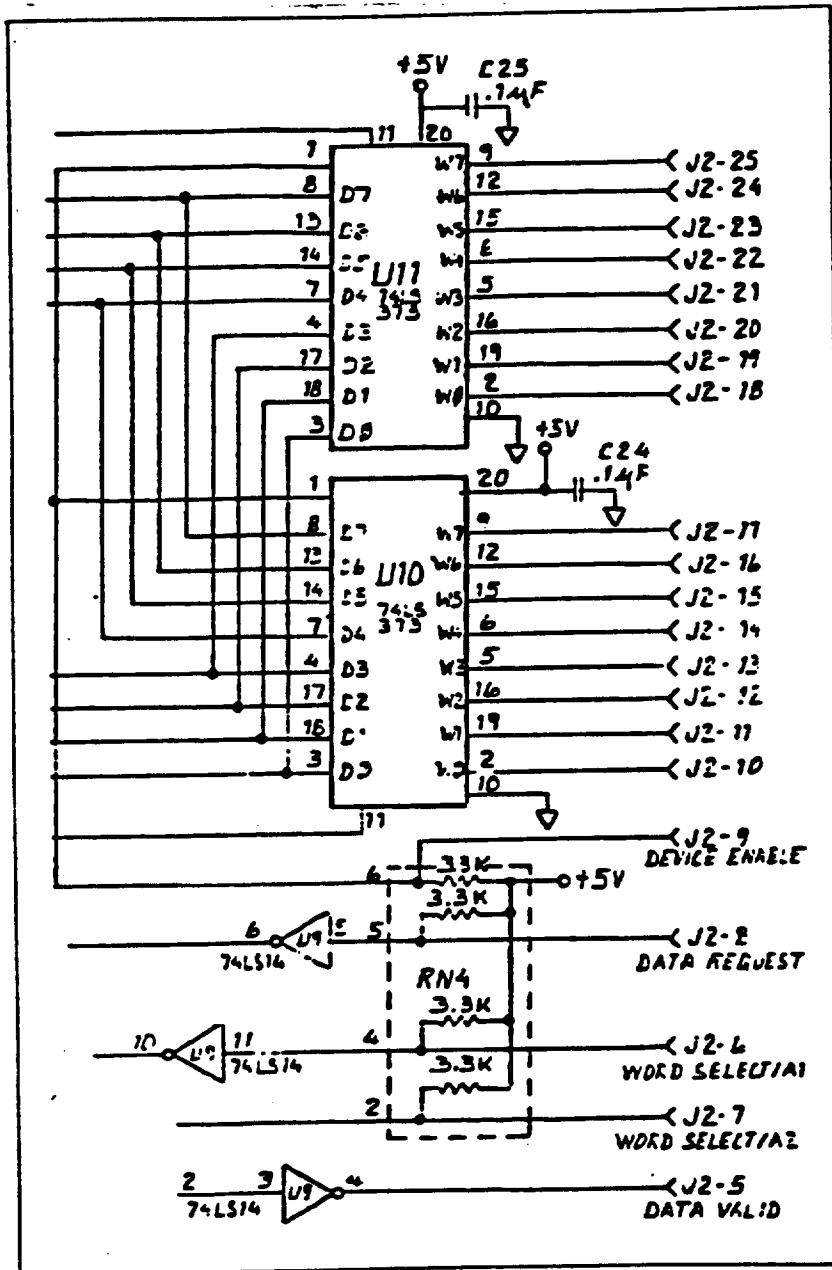

Figure 6-11. Parallel Outputs & Control Inputs (-2 Decoder)

-4 Decoder

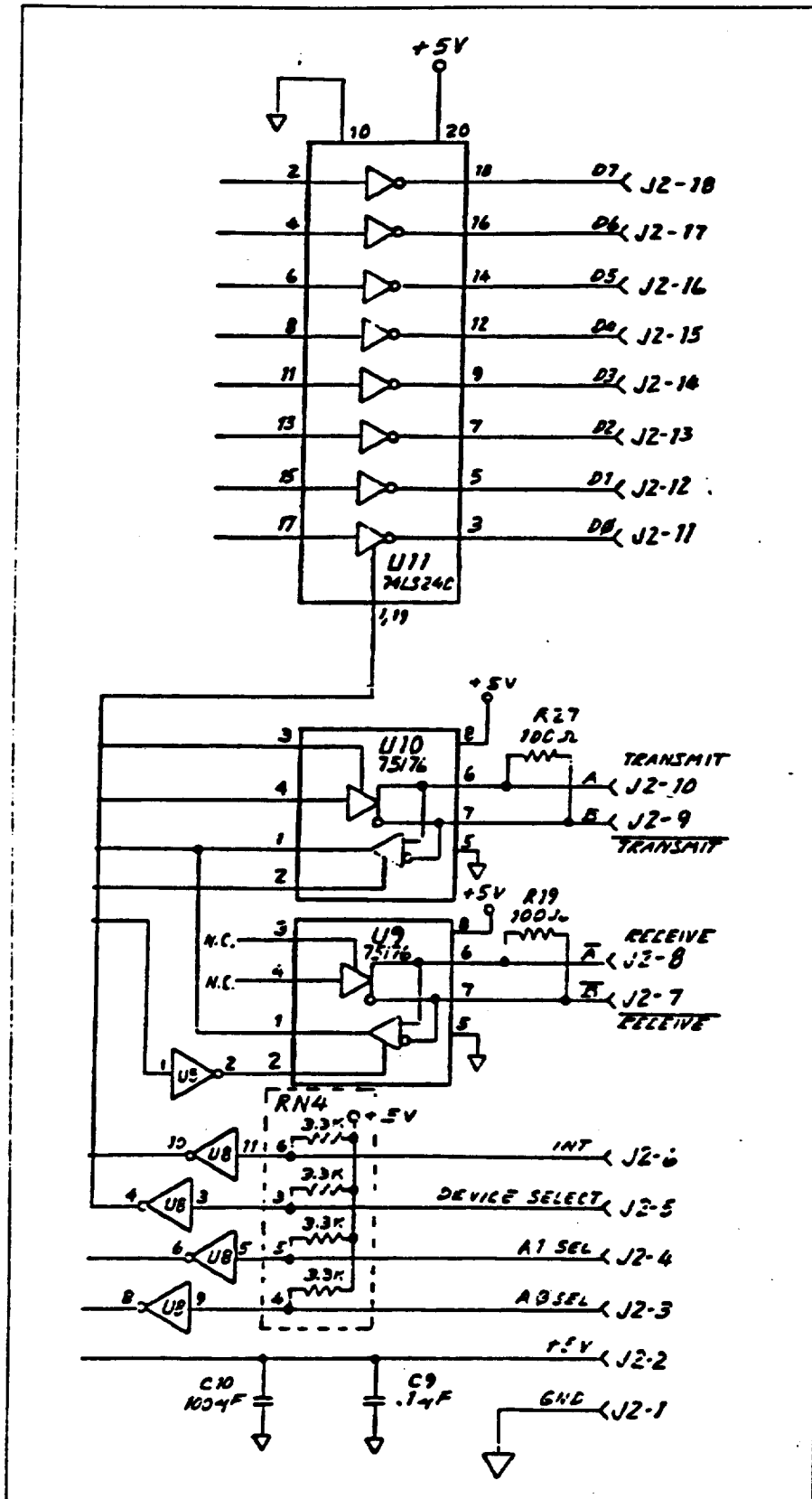

Figure 6-12. Parallel Outputs & Control Inputs (-4 Decoder)

**-1 Decoder Box
DIP Switch and
Jumper Settings**

Setting Description: Switch 3

Switch #	OFF	ON
S1	RS-232C*	RS-422/485
S2	Full Duplex*	Half Duplex
S3	CCW Direction*	CW Direction
S4	8-Bit Parallel	16-Bit Parallel*
S5	Binary (Hex)*	BCD (Decimal)
S6**	Single turn	Multi-turn
S7	Binary Mode*	Mode Select
S8	Binary Mode*	Mode Select-

*Factory-default setting
**This function is determined by the type of encoder used

Table 6-1. -1 Decoder Box Default DIP Switch Settings

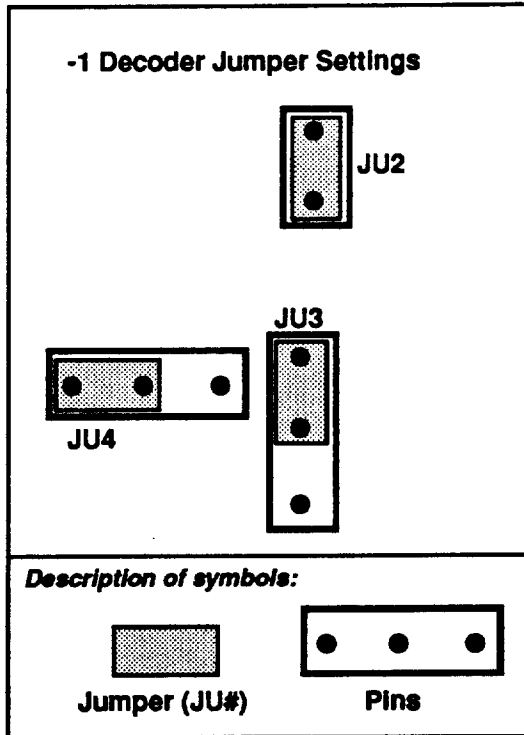

Figure 6-13. Jumper Default Settings

**Numbering Code
Table**

Decimal Digt	BCD Code	Binary Code	Hexadecimal Code
0	0000	0000	0
1	0001	0001	1
2	0010	0010	2
3	0011	0011	3
4	0100	0100	4
5	0101	0101	5
6	0110	0110	6
7	0111	0111	7
8	1000	1000	8
9	1001	1001	9
10	1 0000	1010	A
11	1 0001	1011	B
12	1 0010	1100	C
13	1 0011	1101	D
14	1 0100	1110	E
15	1 0101	1111	F

Table 6-2. Numbering Codes

Chapter 7. MAINTENANCE & TROUBLESHOOTING

Chapter Objectives

The information in this chapter will enable you to:

- Maintain the system's components to ensure smooth, efficient operation
- Isolate and resolve system hardware problems
- Use this chapter as a quick-reference tool for a description of system error codes

Troubleshooting

This section covers the step-by-step procedure to identify and resolve system problems. Troubleshooting is broken into two sections covering serial interface mode only. Each section provides suggestions to help you identify the source of the problem and eliminate the problem.

RS-232C Communications (-1 & -2 Decoders)

Enter `ØRP` to determine if the AR23 reports the set-up parameters. If no echo is even received, switch wires going into decoder box labeled **Rx** and **Tx**. Enter the command again. If you still do not receive a response, remove the decoder box cover and make sure encoder cable is firmly connected to encoder circuit. For the -1 Decoder box, you will not have to remove the cover since the connection is external (outside of the decoder box).

If you are having problems communicating with the indexer, try the following procedure to troubleshoot the communications interface.

1. Make certain the transmit of the host is wired to the receive of the peripheral, and receive of the host is wired to the transmit of the peripheral. *Try switching the receive and transmit wires on either the host or peripheral if you fail to get any communication.*
2. Some serial ports require handshaking. You can then establish three-wire communication by connecting RTS to CTS (usually pins 4 and 5) and DSR to DTR (usually pins 6 to 20).
3. Configure the host and peripheral to the same baud rate, number of data bits, number of stop bits, and parity (refer to Chapter 2, Getting Started for the proper values for these parameters).
4. If you receive double characters, for instance typing **A** and receiving **AA**, your computer is set for half duplex. Change the setup to full duplex.
5. Use DC common or signal ground as your reference, *not* earth ground.

6. Cable lengths should not exceed 50 ft. unless you are using some form of line driver, optical coupler, or shield. As with any control signal, be sure to shield the cable to earth ground at one end only.
7. To test your terminal or terminal emulation software for proper three-wire communication, unhook your peripheral device and transmit a character. You should not receive an echoed character. If you do, you are in half duplex mode. connect the host's transmit and receive lines and send another character. You should receive the echoed character. If not, consult the manufacturer of the host's serial interface for proper pin outs.

If the computer is looking for handshaking signals, you may need to install jumper wires at the terminal end to disable this function. Since the pin-out from various computers are different, refer to your computer's operator's manual for instructions on how to disable the handshaking function. Most computers, however, use the pins shown in Figure 7-1 to install jumpers. For more detailed information on this topic, refer to *RS-232C Made Easy*, published by Prentice -Hall, Inc.

After you have checked your computer, enter **[cr]ORP**. The system should respond with set-up parameters. The reason for entering a **[cr]** before the command is to clear the buffer before you enter the command.

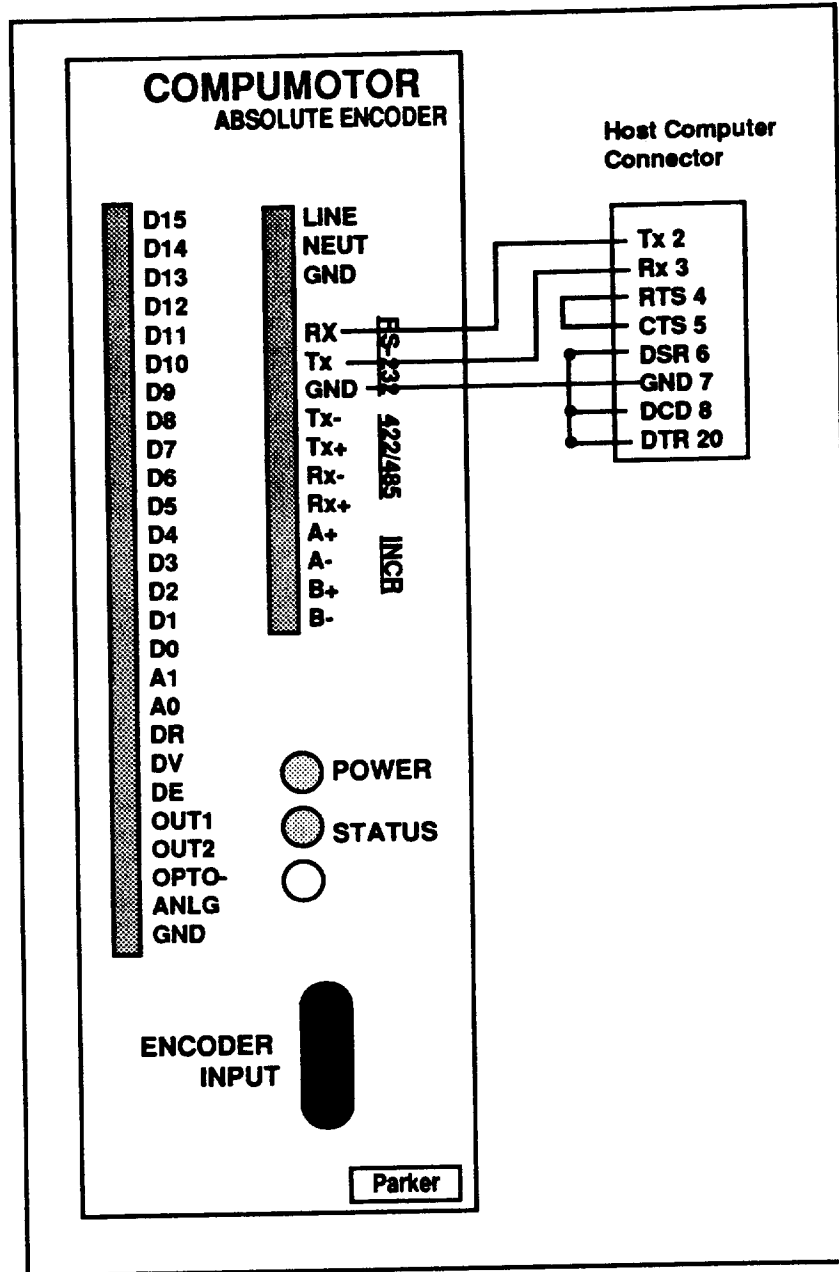

Figure 7-1. Disabling the Handshaking Function

If you still do not received an echo, use another computer to complete this test (determine if the serial port is not compatible with the system or if it is malfunctioning). If this is not possible, contact our Application Department at (800) 358-9068.

If you receive echoed characters, but no parameters are reported, the address preceding the RP command may be something other than 0. The only way to find the proper address is to try all of the numbers in range (0RP - FRP).

**RS-422/485
Communications
(-1 & -4
Decoders)**

If you are using a -1 or -4 Decoder, verify that the DIP switches are properly set (as shown in Chapter 2, Getting Started). Double check the system connections (review Chapter 3, Installation). Type the following command:

ØRP

The response to this command will help you to determine if set-up parameters are reported. If no data is reported, there may be a compatibility problem with the interface circuit that you are using. Since there is no echo with RS-422/485, the next step is to verify that the interface circuit is operating with the following parameters:

- Baud Rate: 9,600
- Data Bits: 8
- Start/Stop Bit(s): 1
- Parity: None

If you receive echoed characters, but no parameters are reported, the address preceding the RP command may be something other than Ø. The only way to find the proper address is to try all of the numbers in range (ØRP - FRP).

**Recommended
RS-422/485
Interface
Devices**

Some customers have made special interface boards that were not compatible with RS-422/485 standards. A listing of interface products that have been used successfully by a variety of AR23 users is provided below.

1. **RS-422/485 to RS-232C converter -B & B model 422CON.** Phone number: (815) 434-0846.
2. **IBM RS-422/485 interface board - Qua-Tech model DS-2Ø1/DS-2Ø2.** Phone number: (216) 434-3154.

If communication problems arise, contact Compumotor's Application Engineering Department at (800) 358-9068.

**Reducing
Electrical Noise**

This section discusses the sources and methods of suppressing electrical noise.

**System
Installation
Recommendations**

To ensure trouble-free operation, you should pay special attention to the environment in which the AR23 will operate, the layout and mounting, and the wiring and grounding practices used. These recommendations are intended to help you easily and safely integrate AR23 into your facility. Industrial environments often contain conditions that may adversely affect solid-state equipment. Electrical noise, atmospheric contamination, or installation may also affect the operation of the AR23 Encoder.

Electrical Noise

When an AR23 is operated in an environment where there is an excess amount of electrical noise, special care must be taken to eliminate sources of possible noise interference. Potential sources of electrical noise include inductive devices such as solenoids, relays, motors, and motor starters when they are operated by a hard contact. For further information on avoiding electrical noise, refer to the technical data section of the *Compumotor Motion Control Catalog*.

Noise suppression devices may be necessary when sources of electrical noise are connected to the same AC power source or are in close proximity to electronic equipment. You may also need to install noise suppression devices if you have multiple drives attached to the same AC power source. Figure 7-2 shows some recommended suppression devices for most small loads. For best results, install these devices as close as possible to the inductive load.

RC	DIODE	VARISTOR (MOV)
		
<p>1. Can be saved for both AC and DC circuits</p> <p>2. Use 500-1000 ohm for R and 0.1 - 0.2 microF @ 200V</p>	<p>For DC circuit only</p>	<p>Can be used for both AC and DC circuits</p>

Figure 7-2. Noise Suppression Devices

Enclosure Considerations

You should install the AR23 in an enclosure to protect it against atmospheric contaminants such as oil, moisture, and dirt. The National Electrical Manufacturers Association (NEMA) has established standards that define the degree of protection that electrical enclosures provide. The enclosure should conform to NEMA Type 12 standards if the intended environment is industrial and contains airborne contaminants. Proper layout of components is required to ensure sufficient cooling of equipment within the enclosure.

**Sources of
Electrical Noise**

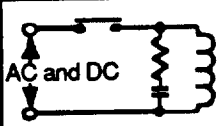
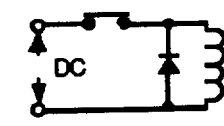
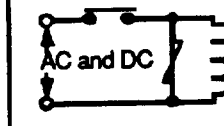
Noise-related difficulties can range in severity from minor positioning errors to damaged equipment from runaway motors crashing through limit switches. In microprocessor-controlled equipment, the processor constantly retrieves instructions from memory in a controlled sequence. If an electrical disturbance occurs, it may cause the processor to misinterpret instruction or access the wrong data. This can be catastrophic to the program and force you to reset the processor. Most Compumotor indexers are designed to with a watchdog timer that shuts down the system if the program is interrupted. This prevents the most damaging failures from occurring.

Since electrical noise is not visible, it is very difficult to detect. You can be certain, however, that noise is generated from the following sources:

- Power line disturbances
- Externally conducted noise
- Transmitted noise
- Ground loops

The following electrical devices are particularly apt to generate unwanted electrical noise conditions:

- Coil-driven devices (conducted and power line noise)
- SCR-fired heaters (transmitted and power line noise)
- Motors and motor drives (transmitted and power line noise)
- Welders: electric (transmitted and power line noise)

Power line disturbances are usually easy to resolve due to the wide variety of line filtering equipment that is available to the motion control industry. Only the most severe electrical noise problems will require you to use an isolation transformer. You will have to use line filtering equipment when other devices connected to the local power line are switching large amounts of current (especially if the switching occurs at a high frequency).

Any device that has coils is likely to disrupt the power line when it is switched off. Surge suppressors, like MOVs (General Electric) are capable of limiting this type of electrical noise. A series RC network across the coil is also an effective means of eliminating the problem (resistance: 500 to 1,000 Ω ; capacitance: 0.1 to 0.2 μF). Coil-driven devices (inductive loads) include relays, solenoids, contactors, clutches, brakes, and motor starters.

**Externally
Conducted Noise**

Externally-conducted noise is similar to power line noise, but the disturbances are created on signal and ground wires that are connected to the indexer. This kind of noise can get into logic circuit ground or into the processor power supply and scramble the program. The problem in this instance is that control equipment often shares a common DC ground wire that may be connected to several devices (such as a DC power supply, programmable controller, remote switches, etc.). When a source of noise like a relay or solenoid is attached to the DC ground, it may cause disturbances within the indexer.

To solve the noise problem caused by DC mechanical relays and solenoids, you must connect a diode backwards across the coil to clamp the induced voltage kick that the coil will produce. The diode should be rated a four times the coil voltage and ten times the coil current. Using solid state relays is another way to eliminate this problem. See Figure 7-2.

Multiple devices on the same circuit should be grounded together at a single point.

Furthermore, power supplies and programmable controllers often have DC common tied to Earth (AC power ground). As a rule, it is preferable to have the indexer signal ground or DC common floating with respect to Earth. This prevents sources of electrical noise that are grounded to Earth from sending noise into the indexer. When you cannot float the signal ground, you should make the Earth ground connection at only one point.

In many cases, optical isolation may be required to completely eliminate electrical contact between the indexer and a noisy environment. Solid state relays provide this type of isolation.

Transmitted Noise

Transmitted noise is picked up by external connections to the indexer, and in severe cases can attack an indexer with no external connections. The indexer enclosure will typically shield the electronics from this, but openings in the enclosure for connections and front panel controls may "leak." As with all electrical equipment, the indexer chassis should be scrupulously connected to Earth to minimize this effect.

When high current contacts open, they draw an arc, producing a burst of broad spectrum radio frequency noise that can be picked up on indexer limit switch or other wiring. High current and high voltage wires have an electrical field around them, and may induce noise on signal wiring, especially when they are tied in the same wiring bundle or conduit.

When this kind of problem occurs, it is time to think about shielding signal cables or isolating the signals. A proper shield surrounds the signal wires to intercept electrical fields, but this shield must be tied to Earth to drain the induced voltages. At the very least, wires should be run in twisted pairs to limit straight line antenna effects.

Most Compumotor cables have shields tied to Earth, but in some cases the shields must be grounded at installation time. Installing the indexer in a NEMA electrical enclosure ensures protection from this kind of noise, unless noise producing equipment is also mounted inside the enclosure. Connections external to the enclosure must be shielded.

Even the worst noise problems, in environments near 600A welders and 25kW transmitters have been solved using enclosures, conduit, optical isolation, and single point ground techniques.

Ground Loops

Ground Loops are the most mysterious noise problems. They seem to occur most often in systems where a control computer is using RS-232C communication. Symptoms like garbled transmissions and intermittent operation are typical.

The problem occurs in systems where multiple Earth ground connections exist, particularly when these connections are far apart.

Suppose a Model 2100 is controlling an axis, and the limit switches use an external power supply. The 2100 is controlled by a computer in another room. If the power supply Common is connected to Earth, the potential exists for ground loop problems. This is because most computers have their RS-232C signal common tied to Earth. The loop starts at the 2100's limit switch ground, goes to Earth through the power supply to Earth at the computer. From there, the loop returns to the 2100 through RS-232C signal ground. If a voltage potential exists between power supply Earth and remote computer Earth, ground current will flow through the RS-232C ground creating unpredictable results.

The way to test for and ultimately eliminate a ground loop is to lift or *cheat* earth ground connections in the system until the symptoms disappear.

Defeating Noise

The best time to handle electrical noise problems is before they occur. When a motion system is in the design process, the designer should consider the following set of guidelines for system wiring in order of importance:

1. Put surge suppression components on all electrical coils: Resistor/capacitor filters, MOVs, Zener and clamping diodes.
2. Shield all remote connection, use twisted pairs. Shield should be tied to Earth at one end.
3. Put all microelectrical components in an enclosure. Keep noisy devices outside, watch internal temperature.
4. Ground signal common wiring at one point. Float this ground from Earth if possible.
5. Tie all mechanical grounds to Earth at one point. Run chassis and motor grounds to the frame, frame to Earth.

6. Isolate remote signals. Solid state relays or OPTO isolators are recommended.
7. Filter the poser line. Use common RF filters, isolation transformer for worst case.

A noise problem must be identified before it can be solved. The obvious way to approach a problem situation is to eliminate potential noise sources until the symptoms disappear, as in the case of ground loops. When this is not practical, use the above guidelines to *shotgun* the installation.

References

Information about the equipment referred to may be obtained by calling the numbers listed below.

- Corcom line filters, (312) 680-7400
- OPTO-22 optically isolated relays, (714) 891-5861
- Crydom optically isolated relays, (213) 322-4987
- Potter Brumfield optically isolated relays, (812) 386-1000
- General Electric MOVs (315) 456-3266
- Teal Electronics Corporation—specializing in power line products—(800) 888-TEAL.

Error Code Descriptions

Error Code	Description	Course of Action
∅	No error present. System is functioning properly.	
1	Not ready for read. Reset must have occurred.	Check your AC power line and ensure that it is clean. If the power line is O.K., apply power and try reading the position again.
2	EEPROM failure. Under this condition, the AR23 will automatically default to factory parameters. If parameters cannot be saved with the SS command, the EEPROM has failed.	Try saving the parameters using the SS command. Cycle power after you complete the save and the error should not re-appear. If the problem persists, you may have a EEPROM problem. Call the factory.
3	Data error. Positional read will need to be repeated. If this persists, noise or a bad component may be the cause.	Check for noise in the encoder. (Refer to the noise reduction procedures explained in this chapter).
5	Fine resolution data error. Position read will need to be repeated. This usually occurs when the electronics are not tuned to the encoder head.	Try to read the position again. If you receive this error on a regular basis, call the factory.

Table 7-1. Error Code Descriptions

All error codes are cleared after every read.

APPENDICES

Command Summary

<u>Command</u>	<u>Description</u>	<u>Default Setting</u>
AR	Auto position report in ASCII	Ø/Auto report disabled
PB	Report present position in binary	
PR	Report present position in ASCII	
RP	Report present parameter settings	
RV	Report software revision level (-1 Decoder only)	
SD	Set Direction of system	Ø/Increasing output CCW
SE	Set (enable) error check	1/Error check enabled
SF	Define scale factor	1/Scale factor multiplier
SL	Define position for Output 2	511.99/Set Output 2 position
SM	Define RS-422/485 full/half duplex	Ø/Full Duplex
SN	Define device address	Ø/Address Ø
SO	Define position offset	Ø/Ø Offset
SP	Define positional data format	1/Output format ASCII decimal
SS	Save set-up parameters in EEPROM	
Z	Hardware and software reset (-1 Decoder only)	

All parameters input must be saved with SS command or they will be lost after power is cycled.

Recommended Third-Party Vendors

Vendor	Product(s)	Address
Metabyte	Models PIO12, COM485, DUAL 422	440 Myles Standish Blvd. Taunton, MA 02780 Phone: (508) 880-3000
Datastorm Technologies	Pro-Comm™	P.O. Box 1471 Columbia, MO 65205 Phone: (314) 449-9401

Glossary

Absolute Positioning

A positioning coordinate reference wherein all positions are specified relative to some reference, or "home" position. This is different from incremental programming, where distances are specified relative to the current position.

Absolute Programming

Refers to a motion control system employing position feedback devices (absolute encoders) to maintain a given mechanical location.

Acceleration

The change in velocity as a function of time. Acceleration usually refers to increasing velocity and deceleration describes decreasing velocity.

Accuracy

A measure of the difference between expected position and actual position of a motor or mechanical system. Motor accuracy is usually specified as an angle representing the maximum deviation from expected position.

Address

Multiple devices, each with a separate address or unit number, can be controlled on the same bus. The address allows the host to communicate individually to each device.

Ambient Temperature

The temperature of the cooling medium, usually air, immediately surrounding the motor or another device.

ASCII

American Standard Code for Information Interchange. This code assigns a number to each numeral and letter of the alphabet. In this manner, information can be transmitted between machines as a series of binary numbers.

Baud Rate

The number of bits transmitted per second. Typical rates include 300, 600, 1200, 2400, 4800, 9600, 19,200. This means at 9600 baud, one character (-10 bits) can be sent nearly every millisecond.

BCD

Binary Coded Decimal is an encoding technique used to describe the numbers 0 through 9 with four digital (on or off) signal lines. Popular in machine tool equipment.

Bit

Abbreviation of Binary Digit, the smallest unit of memory equal to 1 or 0.

Block Diagram

A simplified schematic representing components and signal flow through a system.

Byte

A group of 8 bits treated as a whole, with 256 possible combinations of ones and zeros, each combination representing a unique piece of information. Characters are stored as bytes.

Closed Loop

A broadly applied term relating to any system where the output is measured and compared to the input. The output is then adjusted to reach the desired condition. In motion control, the term is used to describe a system wherein a velocity or position (or both) transducer is used to generate correction signals by comparison to desired parameters.

Daisy-Chain

A term used to describe the linking of several RS-232C devices in sequence such that a single data stream flows through one device and on to the next. Daisy-chained devices usually are distinguished by device addresses, which serve to indicate the desired destination for data in the stream.

Data Bits

Since the ASCII character set consists of 128 characters, computers may transmit only seven bits of data. However, most computers support an eight bit extended ASCII character set.

DCE

Data Communications Equipment transmits on pin three and receives on pin two of a 25 pin D connector.

Dead Band

A range of input signals (steps) for which there is no system response or correction.

Detent Torque

The minimal torque present in an unenergized motor. The detent torque of a Compumotor or step motor is typically about one percent of its static energized torque.

DTE

Data Communications Equipment transmits characters on pin two and receives on pin three of a 25 pin D connector.

Duty Cycle

For a repetitive cycle, the ratio of on time to total cycle time.
Duty Cycle = On Time + (On Time + Off Time)

Efficiency

The ratio of power output to power input.

Encoder

A device which translates mechanical motion into electronic signals used for monitoring position or velocity.

Friction

A resistance to motion caused by surfaces rubbing together. Friction can be constant with varying speed (Coulomb friction) or proportional to speed (viscous friction).

Full Duplex

The terminal will display only received or echoed characters.

Half Duplex

In half duplex mode, a terminal will display every character transmitted. It may also display the received character, resulting in double character displays.

Hand Shaking Signals

RST: Request To Send
CTS: Clear To Send
DSR: Data Set Ready
DTR: Data Terminal Ready
IDB: Input Data Buffer
ODB: Output Data Buffer

Holding Torque

Sometimes called static torque, it specifies the maximum external force or torque that can be applied to a stopped, energized motor without causing the rotor to rotate continuously.

Home

A reference position in a motion control system, usually derived from a mechanical datum. Often designated as the "zero" position.

Hysteresis

The difference in response of a system to an increasing or a decreasing input signal.

IEEE-488

A digital data communications standard popular in instrumentation electronics. This parallel interface is also known as GPIB, or General Purpose Interface Bus.

Incremental Motion

A motion control term that is used to describe a device that produces one step of motion for each step command (usually a pulse) received.

Incremental Programming

A coordinated system where position or distances are specified relative to the current position.

Inertia

A measure of an object's resistance to a change in velocity. The larger an object's inertia, the larger the torque that is required to accelerate or decelerate it. Inertia is a function of an object's mass and its shape.

Inertial Match

For most efficient operation, the system coupling ratio should be selected so that the reflected inertia of the load is equal to the rotor inertia of the motor.

Limits

Properly designed motion control systems have sensors called limits that alert the control electronics that the physical end of travel is being approached and that motion should stop.

Logic Ground

An electrical potential to which all control signals in a particular system are referenced.

Microstepping

An electronic control technique that proportions the current in a step motor's windings to provide additional intermediate positions between poles. Produces smooth rotation over a wide speed range and high positional resolution.

Multi-Dropping

A method of linking several RS-422/485 devices in parallel fashion. The data still flows one bit at a time, but it is faster than RS-232C because the information reaches all devices at the same time. Multi-dropped devices must have unique device addresses. These addresses are used in software command syntax to send data to specific units.

Multiplexing

A method of linking several parallel output devices into a single unit and reading only one unit at a time. This mode of operation involves input/output handshaking. It allows the host to communicate with multiple units while requiring fewer inputs and outputs.

Null Modem

A simple device or set of connectors which switches the receive and transmit lines of a three wire RS-232C connector.

Open Collector

A term used to describe a signal output that is performed with a transistor. An open collector output acts like a switch closure with one end of the switch at ground potential and the other end of the switch accessible.

Open Loop

Refers to a motion control system where no external sensors are used to provide position or velocity correction signals.

OPTO-Isolated

A method of sending a signal from one piece of equipment to another without the usual requirement of common ground potentials. The signal is transmitted optically with a light source (usually a Light Emitting Diode) and a light sensor (usually a photosensitive transistor). These optical components provide electrical isolation.

Parallel

Refers to a data communication format wherein many signal lines are used to communicate more than one piece of data at the same time.

Parity

An RS-232C error detection scheme which can detect an odd number of transmission errors.

Pulse Rate

The frequency of the step pulses applied to a motor driver. The pulse rate multiplied by the resolution of the motor/drive combination (in steps per revolution) yields the rotational speed in revolutions per second.

Ramping

The acceleration and deceleration of a motor. May also refer to the change in frequency of the applied step pulse train.

Rated Torque

The torque producing capacity of a motor at a given speed. This is the maximum torque the motor can deliver to a load and is usually specified with a torque/speed curve.

Relative Accuracy

Also referred to as "Step to Step Accuracy," this specification tells how microsteps can change in size. In a perfect system, microsteps would all be exactly the same size, but drive characteristics and the absolute accuracy of the motor cause the steps to expand and contract by an amount up to the relative accuracy figure. The error is not cumulative.

Repeatability

The degree to which the positioning accuracy for a given move performed repetitively can be duplicated.

Resolution

The smallest positioning increment that can be achieved. Frequently defined as the number of steps required for a motor's shaft to rotate one complete revolution.

Ringling

Oscillation of a system following a sudden change in state.

RS-232C

A data communications standard that encodes a string of information on a single line in a time sequential format. The standard specifies the proper voltage and timing requirements so that different manufacturers' devices are compatible.

RS-422/485

A data communications standard that encodes a string of information on a single line in a time sequential format. The standard runs at high voltage ($\pm 15\text{VDC}$), which allows for longer cable lengths and fewer noise problems.

Slew

In motion control, the portion of a move made at a constant non-zero velocity.

Speed

Used to describe the linear or rotational velocity of a motor or other object in motion.

Start Bits

RS-232C character transmissions begin with a bit which signals the receiver that data is now being transmitted.

Static Torque

The maximum torque available at zero speed.

Step Angle

The angle the shaft rotates upon receipt of a single step command.

Stiffness

The ability to resist movement induced by an applied torque. Is often specified as a torque displacement curve, indicating the amount a motor shaft will rotate upon application of a known external force when stopped.

Stop Bits

When using RS-232C, one or two bits are added to every character to signal the end of a character.

Synchronism

A motor rotating at a speed correctly corresponding to the applied step pulse frequency is said to be in synchronism. Load torques in excess of the motor's capacity (rated torque) will cause a loss of

synchronism. This condition is not damaging to a step motor.

Text/Echo (Off/On)

This setup allows received characters to be re-transmitted back to the original sending device. Echoing characters can be used to verify or "close the loop" on a transmission.

Torque

Force tending to produce rotation.

Torque-to Inertia Ratio

Defined as a motor's holding torque divided by the inertia of its rotor. The higher the ratio, the higher a motor's maximum acceleration capability will be.

TTL

Transistor-Transistor Logic. Describes a common digital logic device family that is used in most modern digital electronics. TTL signals have two distinct states that are described with a voltage—a logical "zero" or "low" is represented by a voltage of less than 0.8 volts and a logical "one" or "high" is represented by a voltage from 2.5 to 5 volts.

XON/XOFF

Two ASCII characters supported in some serial communication programs. If supported, the receiving device transmits an XOFF character to the host when its character buffer is full. The XOFF character directs the host to stop transmitting characters to the device. Once the buffer empties the device will transmit an XON character to signal the host to resume transmission.

Index

- Absolute Encoding Disk 2
- Absolute position 60
- AR23 System Specifications 67
- Assumptions v
- AX-A Drive 11

- CTS 83

- Daisy chain 49
- DC common 89
- DC ground wire 89
- Decoders
 - 1 Decoder 6
 - 16-bit parallel interface 19
 - 8-bit parallel interface 18
 - AX-A Indexer/Drive 15
 - CCW 10
 - CW 10
 - DIP switches 10
 - Full Duplex 10
 - Half Duplex 10
 - JSI Digital Servo Controller 16
 - Jumper Default Settings 12
 - Output Data 11
 - Parallel Communication 11
 - RS-232C 12
 - RS-422/485 14
 - Status Light 7
 - 2 Decoder 20
 - 16-Bit Parallel 22
 - RS-232C 21
 - 4 Decoder 23
 - 8-Bit Parallel Interface 26
 - JSI Digital Servo Controller 24
 - RS-422/485 24
- Mounting 28
 - Minimum depth 28
 - Minimum width 28
- Resolution 6
- Defeating Noise 90
- Device address 64
- DSR 83
- DTR 83

- Earth (AC power ground) 89
- Earth ground 90
- Echo 13
- Electrical Noise 87
- Enclosure Considerations 87
- Encoder Mounting
 - Flange mounting 29
 - NEMA size stepper motors 29
 - Standard servo mount 29
- Encoders 2
 - Multi-turn absolute encoders 3
 - Single-turn absolute encoders 3
- Error checking 62
- Error Code Descriptions 91
- Externally Conducted Noise 89

- Fluid flow 27

- Ground Loops 90
- Ground signal 90

- Hexadecimal 65

- Inputs 37
- Interface modes 35
- Isolate remote signals 91

- JSI Controller 11

- Microelectrical components 90
- MOVs 88
- Multi-drop 51
- Multiplex configuration 54
- Noise suppression devices 87

- O-ring 27
- Output Segments 36
 - Bits 36
 - Bytes 36
 - Words 36
- Outputs 37

- Power supply ground 33
- Power supply requirements 33
- Proper grounding 31

- Reducing Electrical Noise 86
- Redundant gray code 4
- References 91
- Remote connection 90
- RS-232C 90
- RTS 83

- Shielding 36
- Ship Kit List (-1 Decoder box) 7
- Ship Kit List (-2 Decoder box) 20
- Ship Kit List (-4 Decoder box) 23
- Software revision 61
- Sources of Electrical Noise 88
- Surge suppression 90
- System Installation Recommendations 86

- Transmitted Noise 89