

# Compumotor

## AR-C Absolute Encoder User Guide

Compumotor Division  
Parker Hannifin Corporation  
p/n 88-012007-01 D



# ***User Guide Change Summary***

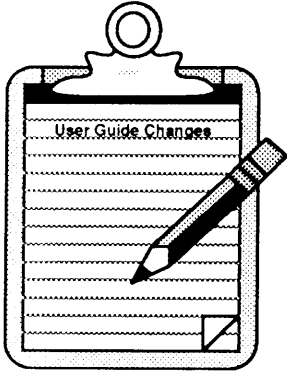

This version of the Absolute Encoder User Guide includes major changes in every section. Many errors and inaccuracies have been corrected and the user guide has been updated to reflect current product information.



# TABLE OF CONTENTS

---

How To Use This User Guide.....	iii
Assumptions for Using This Guide.....	iii
Contents of This Guide.....	iii
Entering Commands.....	iv
CW and CCW (AR-C).....	iv
Related Publications.....	iv
<b>CHAPTER ① INTRODUCTION.....</b>	<b>1</b>
Product Description.....	1
Product Features.....	1
<b>CHAPTER ② GETTING STARTED.....</b>	<b>3</b>
What You Should Have.....	3
Configure Decoder Box.....	3
Opening the Decoder Box.....	4
AR-C Decoder Box Configuration.....	4
Closing the Decoder Box.....	4
How to Connect Power.....	5
Standalone Operation.....	
Bench Test.....	6
RS-232C Interface.....	6
RS-422/485 Interface.....	7
<b>CHAPTER ③ INSTALLATION.....</b>	<b>9</b>
Installation Process Overview.....	9
Installation Procedures.....	9
System Mounting.....	10
mounting.....	10
Decoder.....	10
AR-C Encoder Mounting.....	10
System Connections.....	10
Wiring Guidelines.....	11
Cabling.....	12
Encoder Connections.....	12
Power Connections.....	12
RS-232C Connections.....	12
RS-422/485 Connections.....	13
8-Bit Parallel Connections.....	13
16-Bit Parallel Connections.....	14
Indexer Mode Connections.....	15
Operating with JSI, Model 500, or Model 4000.....	15
Operating With The SX/SXF.....	16
Operating with the AX-A.....	16

<b>CHAPTER ④ STANDALONE OPERATION.....</b>	<b>17</b>
Interface Modes .....	17
Serial Output Control .....	17
Host Computer Operation .....	17
Operating the Serial Interface.....	18
Using Multiple Units On An RS-232C Interface .....	18
Daisy Chaining Three Decoders .....	18
Using Multiple Units on an RS-422/485 Interface .....	20
RS-422/485 interface.....	20
Parallel Output Control.....	21
Parallel Output Examples .....	22
Parallel Output Control.....	22
8-Bit Data Output.....	23
Interpreting 8-Bit BCD Output.....	24
Interpreting 8-Bit Binary Output .....	25
16-Bit Data Output .....	26
Interpreting 16-Bit BCD Output .....	27
Interpreting 16-Bit Binary Output.....	27
Using Multiple Units in Parallel Output Mode .....	28
Offset Pushbutton .....	29
<b>CHAPTER ⑤ HARDWARE REFERENCE.....</b>	<b>31</b>
Dimensional Specifications.....	31
AR-C Encoder Head Dimensions .....	32
Mechanical Specifications.....	33
Electrical Specifications.....	33
I/O Circuit Descriptions.....	33
Environmental Specifications.....	33
Default DIP Switch Settings .....	34
Standalone Mode (RS-232C Serial Interface).....	34
SX Indexer Mode (RS-422C Serial) .....	34
AX-A Indexer Mode (RS-485C Serial) .....	35
JSI, Model 500, and Model 4000 Indexer Mode (Parallel Interface).....	35
Jumper Settings .....	36
<b>CHAPTER ⑥ SOFTWARE REFERENCE .....</b>	<b>39</b>
Command Format Description .....	39
Alphabetical Command Listing.....	42
<b>CHAPTER ⑦ TROUBLESHOOTING &amp; MAINTENANCE.....</b>	<b>49</b>
Troubleshooting.....	49
RS-232C Communications .....	49
RS-422/485 Communications .....	50
Recommended RS-422/485 Interface Devices .....	51
LEDs.....	51
Reducing Electrical Noise .....	51
Diagnostic Code Descriptions.....	51
Returning the System for Maintenance.....	52
<b>INDEX.....</b>	<b>53</b>

# O V E R V I E W

---

---

## How To Use This User Guide

---

This user guide is designed to help you install, develop, and maintain your system. Each chapter begins with a list of specific objectives that should be met after you have read the chapter. This section is intended to help you find and use the information in this user guide.

### Assumptions for Using This Guide

This user guide assumes that you have a fundamental understanding of basic electronics concepts (voltage, switches, current, etc.). With this basic level of understanding, you will be able to effectively use this user guide to install, develop, and maintain your system.

### Contents of This Guide

- |   |  |
|---|--|
| Chapter ①<br>Introduction                     | The introduction chapter describes the product and its specific features. Included in this chapter is a description of how the product operates.   |
| Chapter ②<br>Getting Started                  | This chapter contains a list of items you should have received with your absolute encoder shipment. A bench test that guides you through configuration and hook-up is included in this chapter. The successful completion of the procedures in this chapter allow you to verify that the encoder and its components are in good working order. |
| Chapter ③<br>Installation                     | The installation chapter provides guidelines and instructions for you to properly mount the system and make all electrical connections. Included in this chapter is a table of system specifications. Upon completion of this chapter, your system should be completely installed, tested, and ready to perform basic operations.              |
| Chapter ④<br>Application<br>Design            | This chapter will help you customize the system to meet your application's needs. Important application considerations are discussed. Sample applications are provided.  |
| Chapter ⑤<br>Software<br>Reference            | This chapter describes the X Series commands that are applicable to Compumotor's AR-C. Command syntax and parameters that affect command usage and an alphabetical listing of all commands (with a syntax, command description, and example for each command).   |
| Chapter ⑥<br>Mechanical<br>Reference          | The mechanical reference contains information about the physical characteristics of the encoders described in this guide. It also contains information about accuracy and environmental considerations.  |
| Chapter ⑦<br>Troubleshooting<br>& Maintenance | This chapter contains information that will allow you to identify and resolve system problems.   |

## Entering Commands

---

During installation and feature implementation, you will be asked to send commands over RS-232C (or RS-422/485) to the decoder box. To be executed, each command must be followed by a *delimiter* (space or carriage return).

The decoder ignores command syntax that is not within the valid range for a specific command.

## CW and CCW (AR-C)

---

Throughout this user guide there are references to the AR-C's shaft movement (clockwise—CW or counterclockwise—CCW direction). The CW or CCW direction is determined while facing the front (flange) of the encoder.

## Related Publications

---

- ❑ Current Parker Compumotor Motion Control Catalog
- ❑ *The National Electric Code Handbook (Third Edition)*. Schram, Peter (editor), Quincy, MA. To receive this publication, contact the National Fire Protection Association (Batterymarch Park, MA 02269).

---

---

## Introduction

The information in this chapter will enable you to do the following.

- ❑ You should understand how to use this guide.
- ❑ You should have a general understanding of the AR-C product features.

---

## Product Description

 **Helpful Hint:**  
The AR-C will not lose position data if a power outage occurs.

The AR-C absolute encoder is an easy-to-use feedback device that provides digital position information corresponding to a mechanical location. The need to find a home position or a reference point is eliminated, since an absolute encoding system always knows its location.

The AR-C is supplied with a decoder box that may be used as a standalone interface device or with a Compumotor motion controller. The AR-C is a rotary absolute encoder providing rotary position information. The AR-C is designed to be used independently of a Compumotor motion control system (e.g., standalone). The encoder may be used with an RS-232C, RS-422/485, or 16-bit parallel interface.

---

## Product Features

 **Helpful Hint:**  
A complete AR-C operation description is in Compumotor's current *Motion Catalog*

- ❑ AR-C Features
  - Industry standard size 23 style encoder head with 10-foot cable
  - Two DIP-switch-selectable resolutions (1,024 and 16,384 discrete positions per rev)
  - Multi-turn operation—up to 512 turns max (8,388,608 total discrete positions)
- ❑ Decoder Box Features
  - Integral power supply
  - Microprocessor does the gray scale decoding (eliminates user decoding)
  - Microprocessor monitors for errors and encoder source/sensor failures
  - Interface options:
    - RS-232C interface (with daisy-chain capability)
    - RS-422/485 interface (with multi-drop capability)
    - 8-bit parallel interface (with multi-drop capability)
    - 16-bit parallel interface (with multi-drop capability)
  - Position reports in ASCII decimal, ASCII hexadecimal, or binary for compatibility with any controller
  - Two status LEDs for quick status assessment





# C H A P T E R ②

## Getting Started

The information in this chapter will enable you to do the following:

- Verify that each component of your system has been delivered safely
- Configure the system properly
- Ensure that each component functions properly by bench testing

### What You Should Have

Inspect the encoder system upon receipt for obvious damage to its shipping container. Report any such damage to the shipping company. Parker Compumotor cannot be held responsible for damage incurred in shipment.

#### AR-C Ship Kit

Component/Part	Part Number
AR-C Encoder Head with Cable	72-007839-02
Decoder Box	71-008142-11
Power Cord	44-001609-01
Decoder-to-Indexer Cable	88-012007-01
AR-C User Guide	71-011562-06

### Configure Decoder Box

The decoder box is configured by setting an eight position DIP switch (S3). You must open the decoder box to gain access to the DIP switches. Refer to the diagram and instructions below for DIP switch location and how to open the decoder box.

#### **CAUTION**

The settings shown in the following sections are the recommended settings. There are a number of setting options (*not shown in this chapter*) that you may want to use to suit your particular needs. These options include encoder logical direction, resolution and reporting method, among others. You may refer to *Chapter ⑤ Hardware Reference* for more information on these options.

## Opening the Decoder Box

- 1 Remove power to the unit.

**CAUTION**

Remove power before continuing. There are hazardous voltages in the decoder box.

- 2 Remove the four screws from the corners of the front panel.
- 3 Remove the two screws from the back of the decoder box.
- 4 Grasp the front panel and gently pull the front panel and the attached boards from the encoder housing.

 **Helpful Hint:**  
Facing the front panel, the DIP switches are on the left side of the unit.

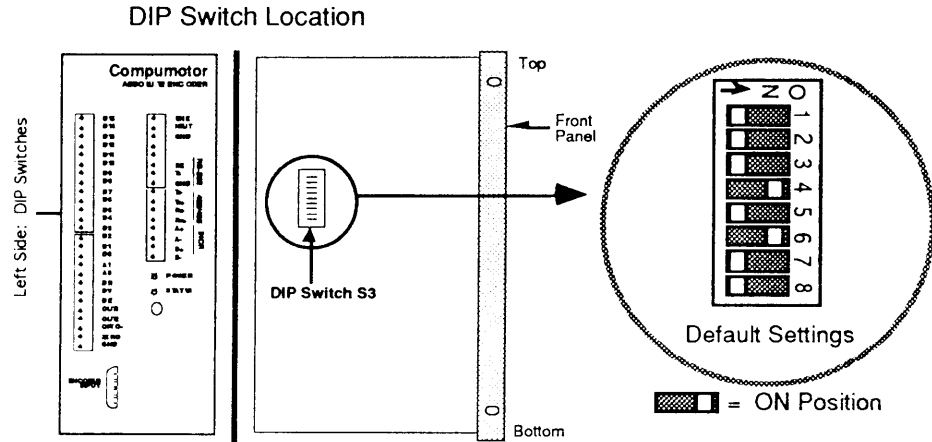

## AR-C Decoder Box Configuration

 **Helpful Hint:**  
DIP Switch changes are not recognized unless the unit is reset or powered down.

This section describes how to configure the decoder box for operation. The decoder box can be used in a **standalone configuration**, or it can be configured with **Compumotor indexers and controllers**.

**CAUTION**

Before applying power to the AR-C, the DIP switches must be properly set for your configuration.

### Standalone Configuration

Use one of the DIP switch configurations below to set the decoder box for standalone use. In Standalone mode, the AR-C, with the decoder box, is connected to a PLC, RS-232C, or RS-422/485 “dumb” terminal, host computer, or just a simple position display. For more on these options, refer to *Chapter 3 Installation* and *Chapter 5 Hardware Reference* of this guide.

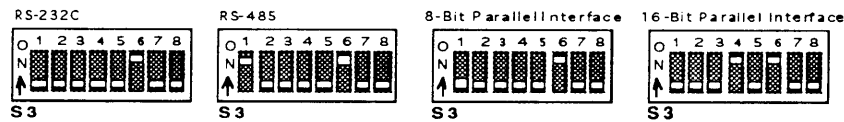

### Compumotor Motion Controller Configuration

Use one of the DIP switch configurations below to set the decoder box for use with Compumotor motion controllers (indexers). For more on these options, refer to *Chapter 3 Installation* and *Chapter 5 Hardware Reference* of this guide.

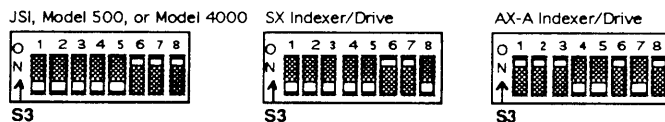

## Closing the Decoder Box

Once the decoder box is properly configured, close it using the steps below.

- 1 Re-insert the printed circuit board into the decoder box housing.
- 2 Replace the two screws into the back of the decoder box.
- 3 Replace the four screws into the corners of the front panel.

# How to Connect Power

Connect the power cord and encoder as shown in the illustration below. Do not apply power yet. Wait until the unit is completely connected as described in the following sections.

## WARNING

Do not apply power to the decoder box until you are instructed to do so later in this chapter.

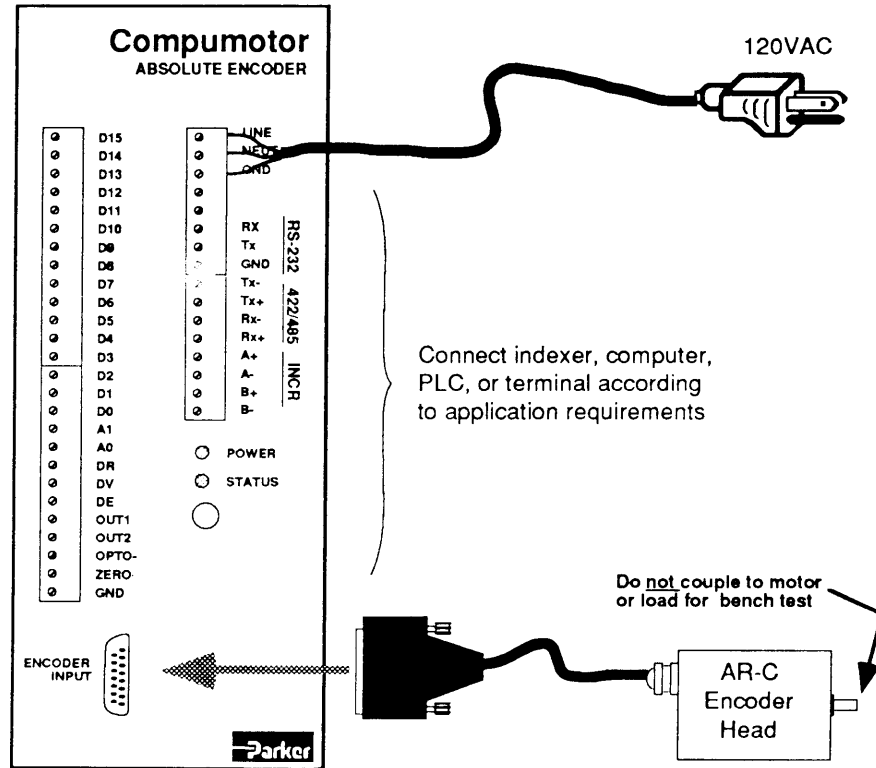

# Standalone Operation Bench Test

 **Helpful Hint:**  
You should have set the decoder box switches as shown in earlier in this chapter.

This section explains how to verify AR-C operation when used with an RS-232C or RS-422/RS-485. In this configuration, the encoder is operating in Standalone mode. **Wiring and bench test instructions for the AR-C and Compumotor indexers (Indexer mode) are provided in Chapter ③ Installation.**

## RS-232C Interface

The RS-232C interface communicates serially using uppercase ASCII characters. Be sure you have followed the configuration procedure at the beginning of this chapter to properly set the DIP switches.

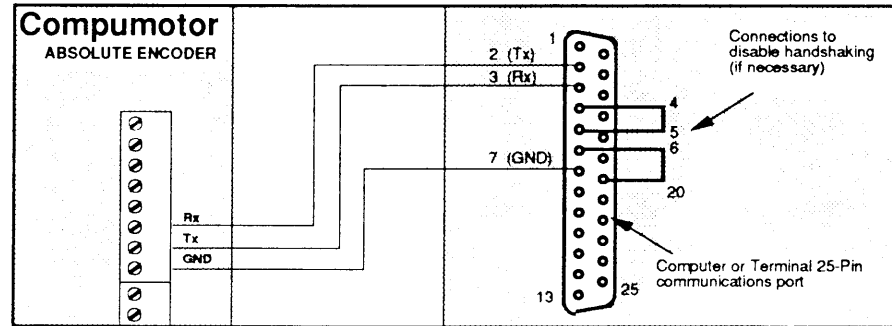

Standalone RS-232C Serial Connections

## RS-232C Verification

To verify that your RS-232C link is operating properly, follow the procedure described below. To perform these steps, you will need a terminal or you may enable a computer to emulate a *dumb terminal*. Software packages such as Pro-Comm™ or Compumotor's XWARE™ allow you to use your computer as a terminal.

The decoder does not accept handshaking in any form. Therefore, you may have to disable the handshaking via software or by jumpering RTS to CTS (usually pins 4 and 5) and DSR to DTR (usually pins 6 and 20) as shown in the above figure. Many terminal emulation software programs allow you to disable handshaking from within the program. Refer to the terminal emulator's documentation for information on how to do this.

 **Helpful Hint:** Use only upper-case ASCII characters when communicating with the decoder box.

- ① **Be sure that power is not applied to the system.**
- ② Plug the encoder 15-pin D connector into the decoder box connector marked **ENCODER INPUT**.
- ③ Connect the decoder box to the computer or terminal (as shown above).
- ④ Apply power to the decoder box (refer to *How to Connect Power* in this chapter). The green POWER LED should illuminate. If it does not, recheck the power connections.
- ⑤ Enable your computer or terminal to operate at the following specifications:
  - Baud Rate: 9,600
  - Start/Stop Bit(s): 1
  - Data Bits: 8
  - Parity: None
- ⑥ After you power up the computer/terminal, press the space bar several times to determine if the computer/terminal is operating properly. If the cursor on the screen moves after you press the space bar, you are receiving an *echo*. Echoes indicate that the computer/terminal is communicating properly with the decoder box.  
  
If you receive an echo, proceed to step ⑦. If no echo is received, refer to *Chapter ⑦ Troubleshooting & Maintenance*.
- ⑦ After verifying that you have received an echo, type **ØPR** followed by pressing the *Return* key. You should receive the following response: `x_nnnnnnnn`

Helpful Hint:  
The x and n values

x = a diagnostic code.

n = a digit from 0 - 9, or A - F (which represents the current absolute encoder position in hexadecimal).

If you do not receive this response, re-enter the command shown above. If you still do not receive the proper response, refer to *Chapter 7 Maintenance & Troubleshooting*.

- Move the encoder shaft manually and repeat step 7. The position report should change. If the position report indicates a change in position, the system is operating properly. Refer to *Chapter 6 Software Reference*, for further information.

## RS-422/485 Interface

The RS-422/485 interface communicates serially using uppercase ASCII characters. Be sure you have followed the configuration procedure at the beginning of this chapter to properly set the DIP switches. Connect the decoder box to the computer or terminal as shown below.

Helpful Hint: The RS-422/485 interface does not provide character echoes.

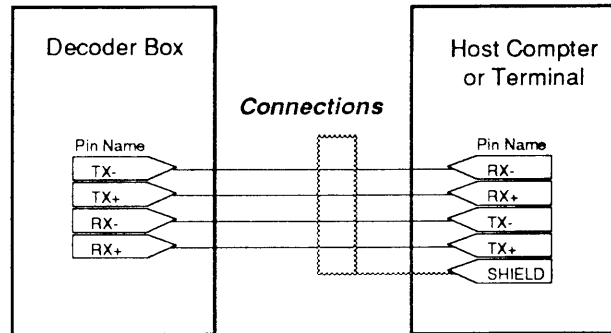

RS-422/485 Full-Duplex Serial Connection

## RS-422/485 Verification

Follow the steps below to verify that the RS-422/485 link is operating properly.

- Be sure that power is not applied to the system.**
- Plug the encoder's 15-pin D connector into the decoder box connector marked **ENCODER INPUT**.
- Connect the decoder box to the computer or terminal as shown above.
- Apply power to the decoder box (refer to *How to Connect Power* section for instructions). The green POWER LED should be illuminated. If it does not, recheck the power connections.
- Enable your computer/terminal to operate at the following specifications:
  - Baud Rate: 9,600
  - Start/Stop Bit(s): 1
  - Data Bits: 8
  - Parity: None
- Type **ØPR** followed by pressing the *Return* key. You should receive the following response: x\_nnnnnnnn
  - x = Diagnostic code,
  - n = Digit from 0 - 9, or A - F (the current absolute encoder position—hexadecimal).If you do not receive this response, re-enter the command shown above. If you still do not receive the proper response, refer to *Chapter 7 Troubleshooting & Maintenance*.
- Move the encoder shaft manually and repeat step 5. The position report response should change. If the position report indicates a change in position, the system is operating properly. Refer to *Chapter 6 Software Reference* for further information.

Helpful Hint: The x and n values



# C H A P T E R ③

---

## ***Installation***

The information in this chapter will enable you to do the following:

- ❑ Mount all system components
- ❑ Make all electrical system connections
- ❑ Ensure that the complete system is installed properly and functions correctly

### **Installation Process Overview**

---

To ensure safe, trouble-free system integration and operation, you should pay special attention to the environment in which the absolute encoder equipment will operate. Environmental conditions include the layout, mounting, and wiring, grounding, and shielding practices used.

### **Installation Procedures**

Before you install this product, you should complete the following steps. If you have any problems, refer to *Chapter ⑦ Maintenance & Troubleshooting*.

- ① Review *Chapter ① Introduction*, (and the user documentation for peripheral equipment) to develop a basic understanding of the system components, their functions, and interrelationships.
- ② Perform bench test as instructed in *Chapter ② Getting Started*.
- ③ Use the procedures in this chapter to tailor the absolute encoder to your particular application.



# System Mounting

This section contains AR-C encoder and decoder box mounting instructions.

## Panel Layout Guidelines

The decoder's circuitry is microprocessor-based and fully digital (all voltages are within TTL levels). For this reason, the unit should be mounted with other control devices on a panel in a NEMA-approved enclosure. The figure below illustrates the minimum required clearances. Electrically noisy devices should be suppressed or housed in separate enclosures.

**Do not mount large, heat-producing equipment directly beneath the decoder.** Logic devices may perform unpredictably if they become too hot. The maximum allowable ambient temperature directly below the decoder is 122°F (50°C). Fan cooling may be required if adequate air flow is not provided.

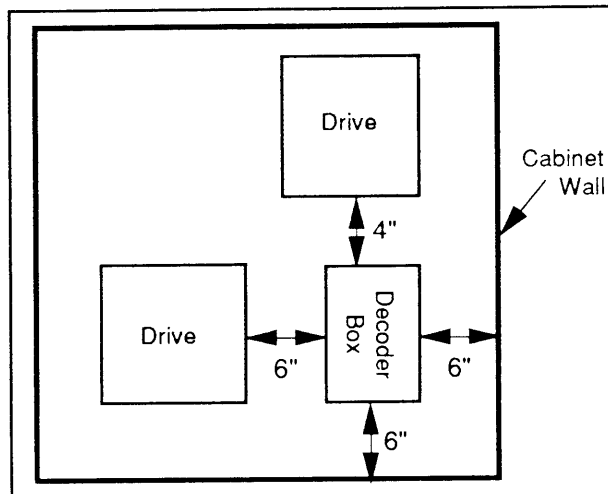

Panel Layout

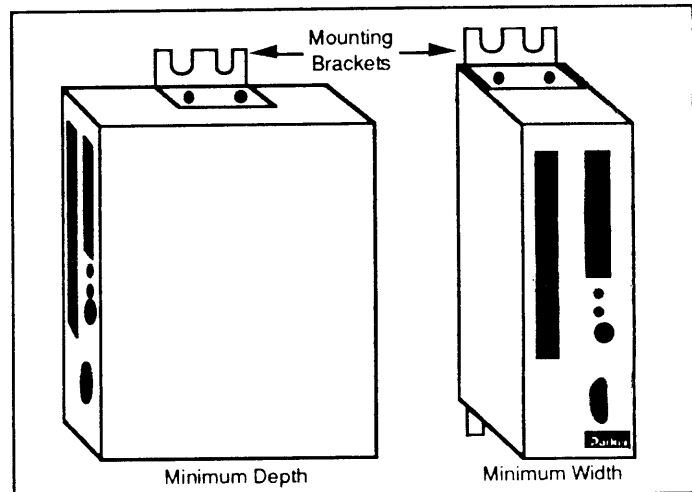

Minimum-Width & Minimum-Depth Options

## Decoder Mounting Options

The decoder box is shipped with two mounting brackets. You can use these brackets to mount the box for minimum width or minimum depth. *Minimum-width* mounting allows more decoder boxes per panel. *Minimum-depth* mounting allows you to use a shallow enclosure. The figure above illustrates where to attach the brackets for the desired mounting configuration.

## AR-C Encoder Mounting

The encoder can be mounted by employing one of three possible methods. These options are listed below.

- ❑ Standard servo mount; tapped holes on the encoder face on a 1.865" bolt circle, with #6-32 tapped holes.
- ❑ The -F option (p/n 72-008140-01) is available for flange mounting. This comes connected to the AR-C providing square construction with unthreaded bolt holes on a 2.741" bolt circle.
- ❑ The -B, -C, and -D options are available for NEMA size stepper motors. This includes the mounting bracket for the encoder and the necessary coupling and screws.
  - -B (p/n 72-008141-01) = NEMA 23 motor
  - -C (p/n 72-008141-02) = NEMA 34 motor
  - -D (p/n 72-008141-03) = NEMA 42 motor

# System Connections

Use the step-by-step procedures in this section to complete the AR-C's electrical connections. The decoder box can be connected to a PLC, dumb terminal, host computer, or a simple position display. *Do not connect the components now. Use the configuration procedures later in this chapter.*

**Helpful Hint:**  
The procedures in this section assume that you have performed all necessary DIP switch and/or jumper modifications to meet your application's requirements. If you have not done so, read *Configure Decoder Box* in Chapter 2.

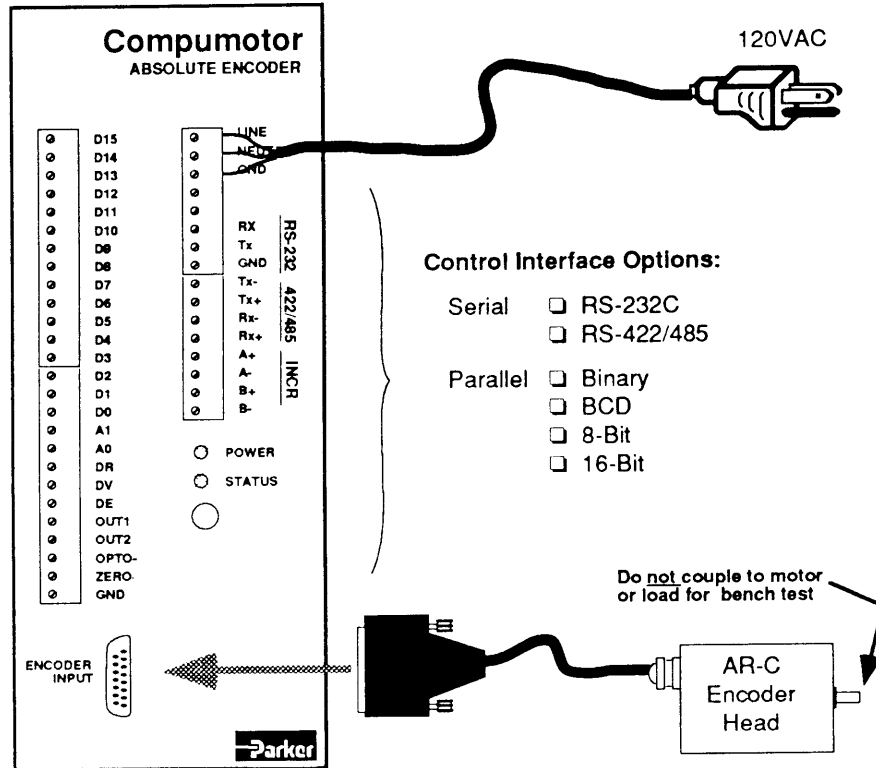

System Configuration

## Wiring Guidelines

Proper grounding of electrical equipment is essential to ensure the safety of personnel. You can reduce the effects of electrical noise due to electromagnetic interference (EMI) by grounding. All Compumotor equipment should be properly grounded. A good source of information on grounding requirements is the National Electrical Code published by the National Fire Protection Association of Boston, Massachusetts.

In general, all components and enclosures must be connected to earth ground through a grounding electrode conductor to provide a low impedance path for ground fault or noise-induced currents. All earth ground connections must be continuous and permanent. Compumotor recommends a single-point (one end only) grounding setup. Prepare components and mounting surfaces prior to installation so that good electrical contact is made between mounting surfaces of equipment and enclosure. Remove the paint from equipment surfaces where the ground contact will be bolted to a panel and use star washers to ensure solid bare metal contact.

For temporary installation, or when you cannot ground the equipment as recommended, connect the **GND** terminal on the AC power connector to the earth ground. Whenever possible, route high-power signals (i.e., motor and power) away from logic signals (i.e., RS-232C, RS-422/485, parallel output) to prevent electrical noise problems.

## Cabling

The cable from the encoder head to the decoder box is made of 15-conductor #26 gauge wire. These wires are not twisted, but they are shielded. The shield is terminated at the decoder box end and is not connected at the encoder end. The standard length is 10 feet.

To minimize interface problems, mount the decoder as close as possible to the controller. Use shielded cables with the shield connected to the controller's earth ground only.

If you mount the AR-C in an environment that contains fluids, always route the cable down from the encoder. This prevents fluid flow on the cable from penetrating into the encoder housing. The same precaution should be used at the decoder box end.

## Encoder Connections

Connect the encoder's 15-pin cable to the **ENCODER INPUT** connector on the decoder box.

## Power Connections

Connect the supplied 120VAC input cable to the decoder box **first**. The green **POWER** LED should illuminate when power is applied.

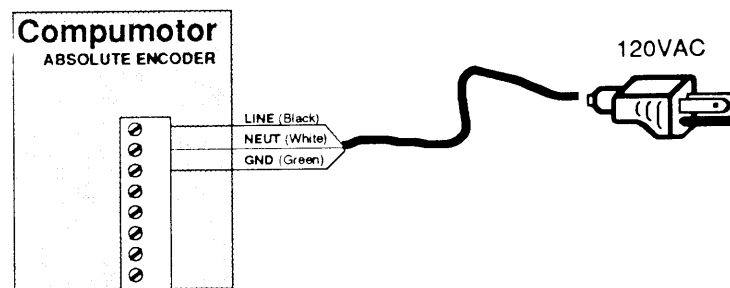

Power Connections to the Decoder Box

## RS-232C Connections

**Helpful Hint:** To use the encoder's set-up and status commands, you must communicate to the decoder over either RS-232C or RS-422/485.

This interface communicates serially (with ASCII characters). With a host computer or dumb terminal, you can scale and offset the position data transmitted over this port.

*Checking first to ensure the power is not applied*, connect the decoder box to the computer or terminal using the diagram below. The decoder does not accept handshaking in any form. Therefore, you should disable the computer's/terminal's handshaking via software or by jumpering RTS to CTS (usually pins 4 and 5) and DSR to DTR (usually pins 6 and 20).

**Helpful Hint:** To verify that the RS-232C link is operating properly, complete the *RS-232C Verification* steps in (Chapter 2 Getting Started)

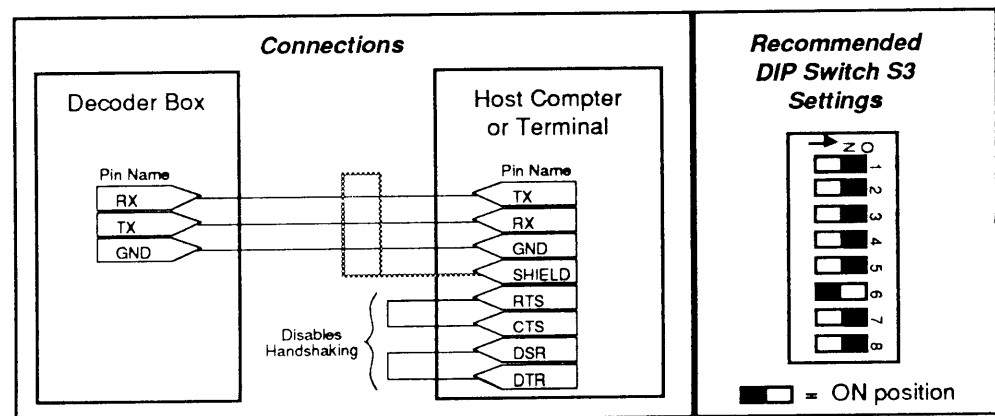

RS-232C Serial Connections (handshaking disabled) and DIP Switch Settings

## RS-422/485 Connections

**Helpful Hint:** To use the encoder's set-up and status commands, you must communicate to the decoder via RS-232C or RS-422/485.

**Helpful Hint:** To verify that the RS-422/485 link is operating properly, complete the *RS-422/485 Verification* steps in (*Chapter 2 Getting Started*)

This interface communicates serially (with ASCII characters—*only upper case characters are valid*). With a host computer or dumb terminal, you can scale and offset the position data transmitted over this port.

**Checking first to ensure the power is not applied**, connect the decoder box to the computer or terminal according the figure below.

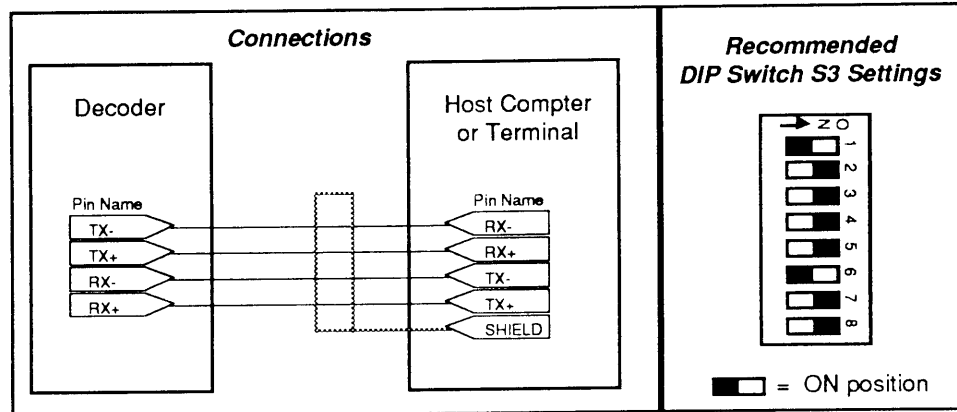

RS-422/485 Full-Duplex Serial Connection and DIP Switch Settings

If you use the configuration setting shown in the figure above, you should be aware the RS-422/485 interface does not provide character echoes.

## 8-Bit Parallel Connections

This optically-isolated interface allows you to transfer data at a higher rate of speed than the serial interface options (RS-232C and RS-422/485). Use the procedure below to configure the decoder for standalone operation over an 8-bit parallel interface. To program the AR-C via its X language commands, you must use an RS-232C or RS-422/485 interface as described above. Connect the decoder box to the host controller 8-bit interface as shown below. **Make sure power is removed from the decoder box.**

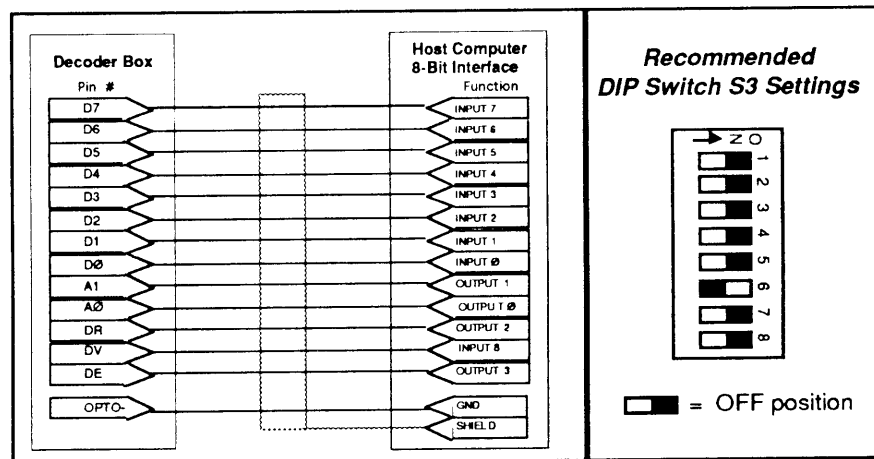

8-Bit Parallel Connections and DIP Switch Settings

# 16-Bit Parallel Connections

**Helpful Hint:** If you are not using 16-bit parallel communications in your application, ignore this section.

This optically-isolated interface allows you to transfer data at a higher rate of speed than the 8-bit parallel interface. More interface wires are required for this interface. *Remember: To program the AR-C via its X language commands, you must use an RS-232 or RS-422/485 interface as described above.* Connect the decoder box to the host parallel interface or programmable controller. The diagram below illustrates the input and output signals. **Make sure power is removed from the decoder box.**

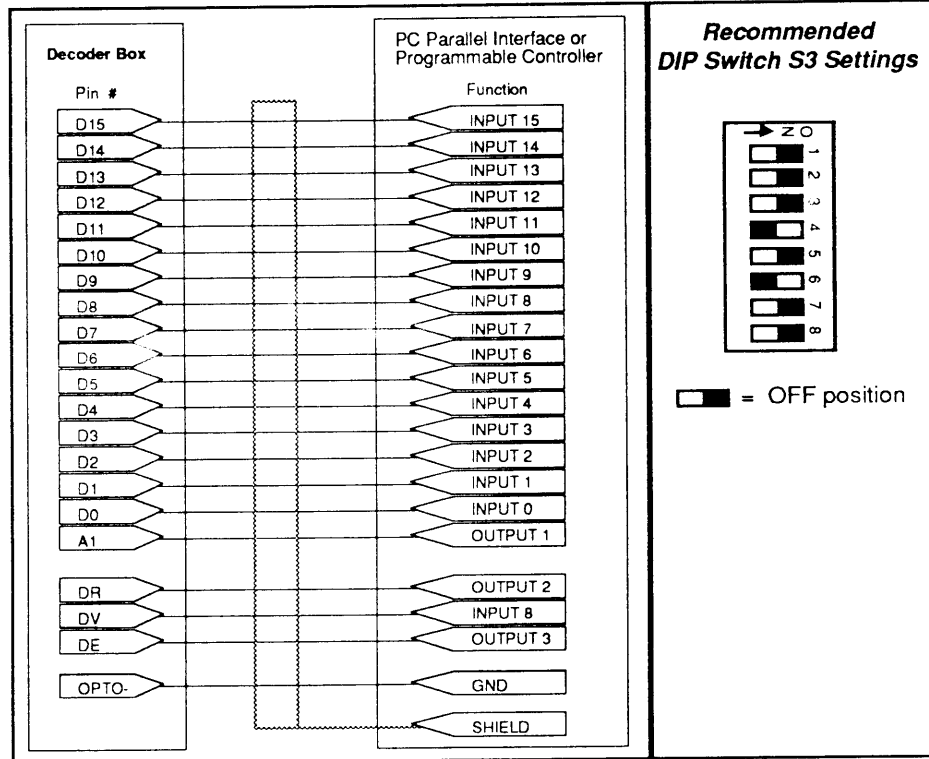

16-Bit Parallel Connections and DIP Switch Settings

# Indexer Mode Connections and Bench Test

In Indexer Mode, the encoder is connected to a Compumotor indexer and functions solely as an absolute position transducer. It does not provide scaling or device addressing. The AR-C is compatible with the JSI Servo Controller, Model 500 Indexer, Model 4000 Controller, SX Indexer/Drive, and AX-A Indexer/Drive. Refer to *Chapter 2 Getting Started* for information on how to configure the DIP switches.

*DIP switch 3 should be configured such that increasing encoder position matches increasing motor position. If DIP switch 3 is off, increasing encoder counts correspond to CCW shaft rotation (when facing the encoder face).*

## Operating with JSI, Model 500, or Model 4000

Use the following procedure to configure the decoder box for operation with Compumotor controllers (JSI, Model 500, or Model 4000).

### CAUTION

Use **only** the configuration procedures that are relevant to your application.

- ① Connect the decoder box to the controller/indexer using a shielded cable with a **maximum length of 6 feet** (1.8 meters). Refer to the appropriate diagram below for connection details.
- ② To verify that the AR-C and the controller/indexer operate properly together, refer to absolute encoder verification procedures in the user guide for the Compumotor controller/indexer you are using.

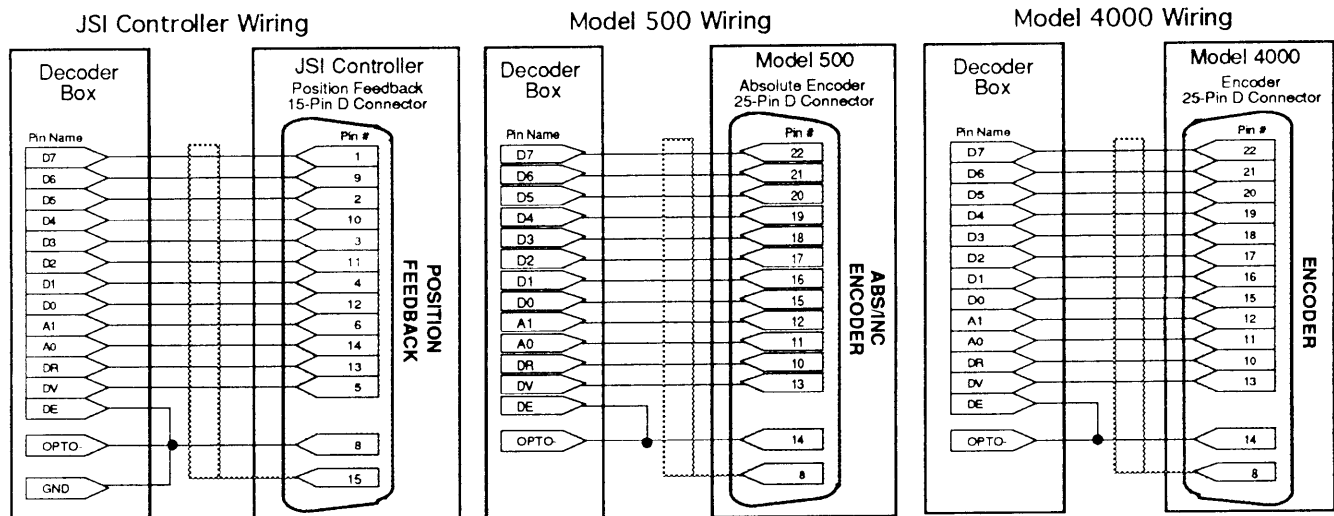

AR-C Decoder Box Connections to Compumotor Controllers/Indexers

### CAUTION

When using the AR-C with the Model 500, be sure to use the **ABS/INC ENCODER** connector on the Model 500.

When using the AR-C with the JSI, you must provide a 15-pin D connector.

## Operating With The SX/SXF

Use the following steps to configure the decoder for operation with the SX/SXF Indexer/Drive.

- ① Connect the decoder box to the indexer using a shielded cable with a **maximum length of 200 feet** (61 meters), Refer to the appropriate illustration below for connection details.
- ② To verify that the AR-C and the SX operate properly together, refer to absolute encoder verification procedures in the user guide for the SX Indexer/Drive.

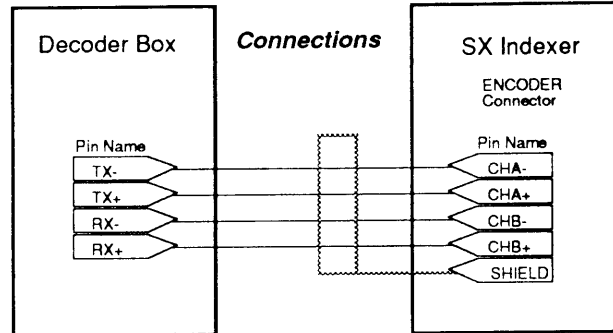

Connections to the SX

## Operating with the AX-A

The AR-C can interface with Compumotor's microstepping AX-A Indexer/Drive. This interface requires both incremental and absolute encoder data. Incremental encoder data is used during a move, and absolute encoder data is used during power-up to synchronize the AX-A position counters. After a move, the AX-A can request the absolute position from the AR-C and compares it with its internal position counter. For more information, refer to the **AX-A User Guide**.

Configure Decoder Box for the AX-A

Be sure to configure the decoder box as described in the beginning of this chapter, then connect the decoder box to the AX-A as shown in the figure below.

To verify that the AR-C and AX-A operate properly together, refer to *Verifying Absolute Encoder Connections* in Chapter ③ *Installation of the **AX-A User Guide***.

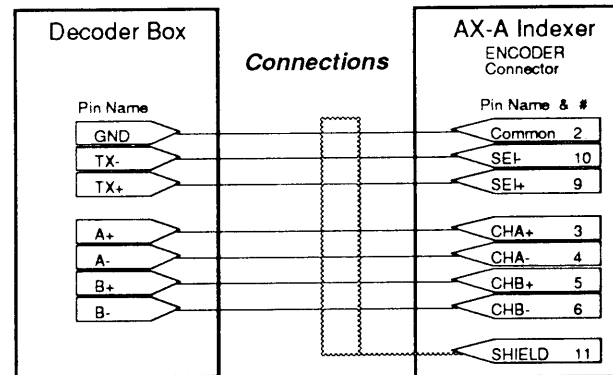

Connections to the AX-A

---



---

## Standalone Operation

 **Helpful Hint:**  
If you are use the AR-C with a Compumotor controller or indexer, refer to that product's user guide for more information on operation with an encoder.

The information in this chapter will enable you to:

- Recognize and understand important considerations that you must address before you implement your application
- Understand the capabilities of the system
- Customize the system to meet your requirements

*You must complete the steps in Chapter ② Getting Started, and Chapter ③ Installation, that pertain to your application before you perform the steps in this chapter. **You only need to follow the examples that apply to your application. Skip examples that do not apply to your application.***

---

### Interface Modes

There are two interface modes that allow you to obtain the encoder's position—serial and parallel. The serial interface includes RS-232C and RS-422/485. The parallel interface includes 8-bit and 16-bit output. Prior to using either interface, you must define certain parameters within the unit for the application.

---

### Serial Output Control

In Serial mode, absolute data can be transmitted in several different formats. These formats can be selected via software position requests and set-up commands. Refer to *Chapter ⑥ Software Reference* for more command descriptions and parameters.

### Host Computer Operation

If you use the AR-C encoder with a host computer, two interface options are available (depending upon the decoder that you use). The decoder provides a DIP switch-selectable interface for either RS-232C or RS-422/485.

#### Serial Interface Advantages

- Wiring required is minimal (usually from 3 - 5 wires).
- If you use RS-422/485, the length of wire from decoder box can be up to 4,000 feet. If you use RS-232C, length of wire can be up to 20 feet.
- Greater capabilities available with status and set-up commands.
- Simple wiring implementation required for multiple unit connection.

#### Serial Interface Disadvantage

- Transfer of data is limited. Only one character can be transmitted every millisecond.



## Operating the Serial Interface

The host must be a *dumb terminal*, or have software that allows the computer to emulate a *dumb terminal*. Before proceeding, enable the host computer for the following protocol:

- Baud Rate: 9,600
- Data Bits: 8
- Start/Stop Bit(s): 1
- Parity: None

## Using Multiple Units On An RS-232C Interface

If you intend to use more than one decoder (i.e., a daisy chain configuration), verify that each unit is communicating properly (as specified in *Chapter 2 Getting Started*). Ensure proper communications with each unit *before you configure your daisy chain*.

 **Helpful Hint:**  
The AR-C actually echoes characters at less than 9600 baud. Only AR-C's should be in the daisy chain.

When you use multiple decoders with a single RS-232C interface, you can include a maximum of four decoders in your daisy chain configuration. *Each decoder configured on the daisy chain must have a unique device address.* You can assign a unique device address with the **SN** (Define Device Address) command. The factory default address assigned to every decoder is  $\emptyset$ . Refer to *Chapter 6 Software Reference* for more information on the **SN** command. This section provides a step-by-step procedure for assigning unique device addresses for your decoders. *Do not attempt to assign device addresses at this time.*

Refer to the figure below for an example of proper daisy chain wiring. Check the configuration instructions in *Chapter 2 Getting Started* and complete the steps provided below **before** wiring the daisy chain to ensure that your system is properly configured.

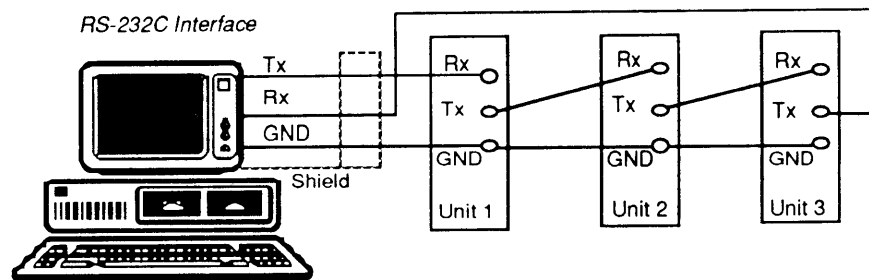

RS-232C Daisy Chain Configuration

## Daisy Chaining Three Decoders

To perform this example, you must have three decoders. You will wire the units to the single RS-232C interface **one at a time** to assign unique device addresses for each unit. At the conclusion of this procedure, you will be able to complete the daisy chain configuration.

- ① After verifying that each decoder is functioning properly, wire one of the units to the host computer (as per the instructions in *Chapter 2 Getting Started*) apply power to the all of the units. Enter the following command on your keyboard to the decoder box: **ØSN1**  
This command changes the device address of this unit to **1**.
- ② To save this unique address setting to nonvolatile memory, enter the following command: **1SS**  
This unit now has a unique device of **1**. Verify the address change by entering **1PR** (the system should respond with a position report). Remove power from the system. Disconnect this unit from the RS-232C interface and wire another one of the units to the interface. Re-apply power.

- ③ To assign a unique device address to this unit, enter the following command:  
**ØSN2**  
This command changes the device address of this unit to **2**.
- ④ To save this unique address setting to nonvolatile memory, enter the following command: **2SS**  
This unit now has a unique device of **2**. *Verify the address change by entering **2PR** (the system should respond with a position report). **Remove power from the system.** Disconnect the unit from the RS-232C interface.*  
*At this point, all three of the decoders have a unique device address (Ø, 1, and 2—the decoder you did not change maintains the default address setting of Ø). Wire the daisy chain configuration as shown in the figure above.*
- ⑤ Apply power to the three decoders and the computer/terminal. Press the space bar on your keyboard. If the cursor on the screen moves, you are receiving an echo. This indicates that the RS-232C communication link is working properly (from computer/terminal to decoder and from decoder back to computer/terminal). If your cursor does not move when you press the space key, check your wiring connections (refer to the figure above and repeat this step. If the problem persists, refer to *Chapter 7 Troubleshooting & Maintenance*).
- ⑥ After you successfully receive an echo, enter the following commands (you will receive a response after each command): **ØPR 1PR 2PR**  
The **PR** (Position Report) command provides a position report. You should receive a position report for each decoder with these commands. If you do not receive the position reports, check your wiring.
- ⑦ Manually move the encoder shaft position of the encoder with the unique device address of Ø. To see the change in position, type the following command: **ØPR**  
The position report for this unit's position should differ from the position report you received for this unit in Step ⑥.
- ⑧ Manually move the encoder shaft position of the encoder with the unique device address of 1. To see the change in position, type the following command: **1PR**  
The position report for this unit's position should differ from the position report you received for this unit in Step ⑥.
- ⑨ Manually move the encoder shaft position of the encoder with the unique device address of 2. To see the change in position, type the following command: **2PR**  
The position report for this unit's position should differ from the position report you received for this unit in Step ⑥.  
The successful completion of these steps verify that all of the decoders configured on your daisy chain are operating properly. If you encounter problems, check your wiring and try this procedure again (from Step ①), or refer to *Chapter 7 Troubleshooting & Maintenance*.

## Using Multiple Units on an RS-422/485 Interface

If you intend to use more than one decoder (i.e., a multi-drop configuration), verify that each unit is communicating properly (as specified in *Chapter 2 Getting Started*). Ensure proper communications with each unit *before you configure your multi-drop system*.

When you use multiple units with the RS-422/485 interface, you can multi-drop up to 16 units to one host serial port. *Each decoder wired on a multi-drop configuration must have a unique device address*. You can assign a unique device address with the **SN** (Define Device Address) command. The factory default address assigned to every decoder is 0. Refer to *Chapter 5 Software Reference* for more information on the **SN** command. *Do not attempt to assign device addresses at this time*.

Refer to the figure below for an example of proper multi-drop wiring. Check the configuration instructions in *Chapter 2 Getting Started* and complete the steps provided below **before** wiring the multi-drop configuration to ensure that your system is properly configured.

 **Helpful Hint:**  
If more than one unit is multi-dropped, remove jumpers JU4 and JU5. You should do this to all units that you intend to multi-drop, **except one**. The last unit in the configuration should maintain the default jumper settings (jumper settings only).

### Decoders

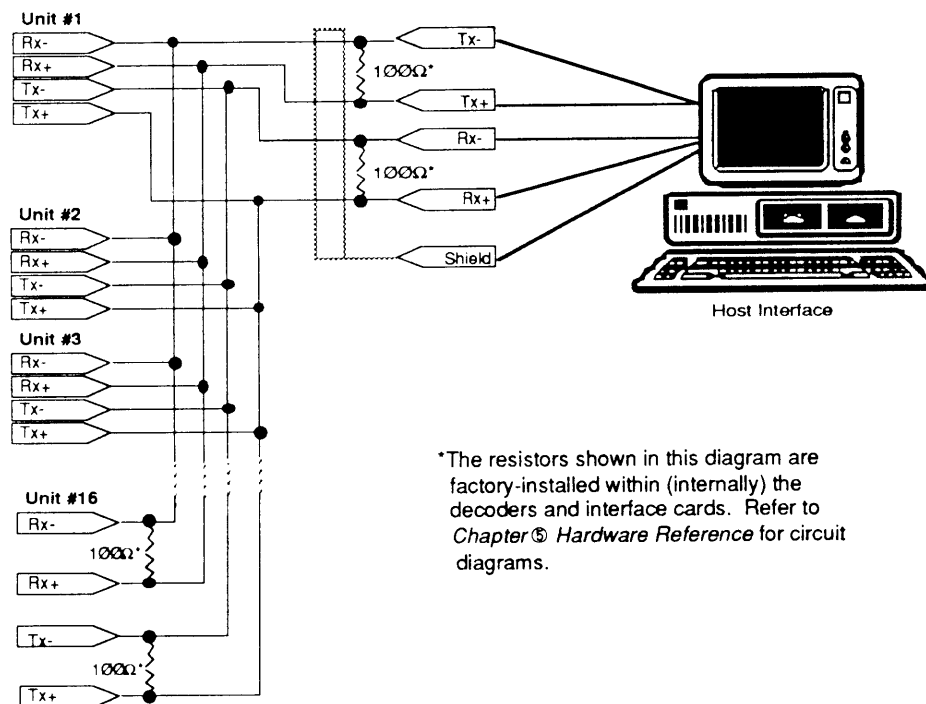

\*The resistors shown in this diagram are factory-installed within (internally) the decoders and interface cards. Refer to *Chapter 9 Hardware Reference* for circuit diagrams.

AR-C Multi-Drop Wiring

## Multi-Dropping Three Decoders

To perform this example, you must have three decoders. You will wire the units to the single RS-422/485 interface one at a time to assign unique device addresses for each unit. At the conclusion of this procedure, you will be able to complete the multi-drop configuration.

- ① After verifying that each decoder is functioning properly, wire one of the units to the host computer (as per the instructions in *Chapter 2 Getting Started*) apply power to the all of the units. Enter the following command on your keyboard to the decoder box: **0SN1**  
This command changes the device address of this unit to 1.
- ② To save this unique address setting to non-volatile memory, enter the following command: **1SS**

This unit now has a unique device of **1**. *Verify the address change by entering **1PR** (the system should respond with a position report)*. Remove power from the system. Disconnect this unit from the RS-422/485 interface and wire another one of the units to the interface. Re-apply power.

- ③ To assign a unique device address to this unit, enter the following command:  
**ØSN2**

This command changes the device address of this unit to **2**.

- ④ To save this unique address setting to nonvolatile memory, enter the following command: **2SS**

This unit now has a unique device of **2**. *Verify the address change by entering **2PR** (the system should respond with a position report)*. **Remove power from the system.** Disconnect the unit from the RS-422/485 interface.

*At this point, all three of the decoders have a unique device address (Ø, 1, and 2—the decoder you did not change maintains the default address setting of Ø). Wire the multi-drop configuration as shown in the figure above.*

- ⑤ Apply power to the three decoders and the computer/terminal.  
⑥ After you successfully receive an echo, enter the following commands (you will receive a response after each command): **ØPR 1PR 2PR**

The **PR** (Position Report) command provides a position report. You should receive a position report for each decoder with these commands. If you do not receive the position reports, check your wiring.

- ⑦ Manually move the encoder shaft position of the encoder with the unique device address of Ø. To see the change in position, type the following command: **ØPR**

The position report for this unit's position should differ from the position report you received for this unit in Step ⑥.

- ⑧ Manually move the encoder shaft position of the encoder with the unique device address of **1**. To see the change in position, type the following command: **1PR**

The position report for this unit's position should differ from the position report you received for this unit in Step ⑥.

- ⑨ Manually move the encoder shaft position of the encoder with the unique device address of **2**. To see the change in position, type the following command: **2PR**

The position report for this unit's position should differ from the position report you received for this unit in Step ⑥.

The successful completion of these steps verify that all of the decoders configured on your multi-drop configuration are operating properly. If you encounter problems, check your wiring and try this procedure again (from Step ①), or refer to *Chapter 7 Troubleshooting & Maintenance*.

#### Application Considerations

If the transmission lines are long, termination of these lines is critical. In Multi-drop configurations, avoid Y's in the line. If branches must be made, terminate each branch with a termination resistor. Improper line termination will cause the system to generate extra characters and corrupt characters during communication.

## Parallel Output Control

---

This interface can output eight (DØ-D7) bits, or sixteen (DØ-D15) bits of data, depending on the DIP switch selector. The full-position output of the AR-C Encoder is 32 bits. This data is read in segments.

When you read BCD or binary parallel output, the serial interface will be disabled. You must complete the parallel read cycle (4 bytes ) before you can establish the serial interface. In this application, you must complete the read cycle and bring the DR, DE, A1, and AØ inputs to the 5VDC level before establishing the serial interface.

**Helpful Hint:**  
All data should be read from the least-significant segment to the most-significant segment. The figure shows each portion of the data in bytes.

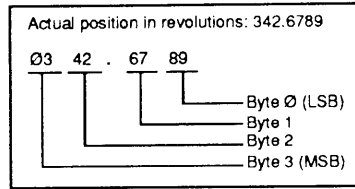

Byte Pattern For Output Data

**Helpful Hint:**  
Schematics of the AR-C outputs are provided in Chapter 6 Hardware Reference

Each output can sink or source up to 15 mA of current, with an output voltage level of +5VDC. The output data can be provided in binary or BCD format. The output format is software selectable with the **SP** command or hardware selectable with the DIP switches inside the decoder box. The state of address inputs A0 and A1 determine which segment of position data is to be read.

All inputs are normally high and are pulled up to +5VDC. To activate the inputs, the input must be grounded. Outputs are normally in a high-impedance state with leakage current under 20µA.

## Parallel Output Examples

The examples in this section illustrate how to operate the AR-C to obtain position data in BCD and binary format for 8-bit and 16-bit output. These examples are based on a random position value.

You can select BCD or binary output modes with the **SP** (Define Data Output) command or DIP switch 5 before you read the data.

To use the data provided from the encoder, you must convert the decoder's output into position information. The PLC or computer should read each byte shown in the tables and perform the math functions shown for accurate and meaningful position data.

## Interpreting Parallel Data

Byte	Byte Value	Byte	Byte Value
0 0 0 0	0	1 0 0 0	8
0 0 0 1	1	1 0 0 1	9
0 0 1 0	2	1 0 1 0	A
0 0 1 1	3	1 0 1 1	B
0 1 0 0	4	1 1 0 0	C
0 1 0 1	5	1 1 0 1	D
0 1 1 0	6	1 1 1 0	E
0 1 1 1	7	1 1 1 1	F

Byte Conversion Table

# 8-Bit Data Output

This section explains the process of reading a position in 8-bit segments. Wire and configure your decoder (DIP switches) as described in prior chapters. To read a position (4 bytes) from the AR-C Encoder, follow the steps below.

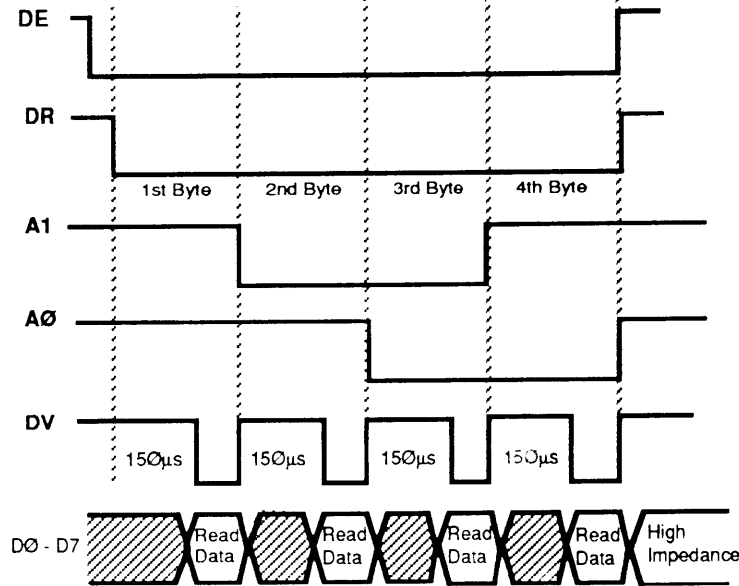

Timing—8-Bit Parallel Output

If you are using only one AR-C Encoder, ground the Device Enable (DE) input. The Device Enable input allows the selected encoder to respond to position requests. If you multiplex more than one unit, the Device Enable input will select which output the system will read. *DE must be active before you attempt to read position information.* The Data Request (DR) output must remain active during the entire data transfer (all four bytes). A1 and A0 select which segment to read. The Data Valid (DV) output signals you when the data is stable or ready.

- ① Ground the Device Enable (DE) and then Data Request (DR) inputs. Request the first byte (least significant byte—LSB) by bringing address selects A0 and A1 high.
- ② Wait for the Data Valid (DV) output to go low. **Read the first byte.**
- ③ Request the second byte. Leave the DR and DE outputs grounded. Leave Address Select A0 high and ground A1.
- ④ Wait for the Data Valid (DV) output to go low. **Read the second byte.**
- ⑤ Request the third byte. Leave address select A1 grounded and ground A0.
- ⑥ Wait for the Data Valid (DV) output to go low. **Read the third byte.**
- ⑦ Request the fourth byte (most significant byte—MSB). Leave address select A0 grounded and bring A0 high.
- ⑧ Wait for the Data Valid (DV) output to go low. **Read the fourth byte.**
- ⑨ Bring all of the inputs high.

## Interpreting 8-Bit BCD Output

The encoder position at the time of the read is **0249.3556** turns.

### 1st Byte (LSB)

Terminal Number	D7	D6	D5	D4	D3	D2	D1	D0
BCD Value	0	1	0	1	0	1	1	0
	Position Byte Value = 5				Position Byte Value = 6			

### 2nd Byte

Terminal Number	D7	D6	D5	D4	D3	D2	D1	D0
BCD Value	0	0	1	1	0	1	0	1
	Position Byte Value = 3				Position Byte Value = 5			

### 3rd Byte

Terminal Number	D7	D6	D5	D4	D3	D2	D1	D0
BCD Value	0	1	0	0	1	0	0	1
	Position Byte Value = 4				Position Byte Value = 9			

### 4th Byte (MSB)

Terminal Number	D7	D6	D5	D4	D3	D2	D1	D0
BCD Value	0	1	1	0	0	0	1	0
	Error Code (D5, D6, D7) = 3 Sign Bit (D4) = +				Position Byte Value = 2			

 **Helpful Hint:**  
This value will be frozen until the Data Request input returns to its high or off state.

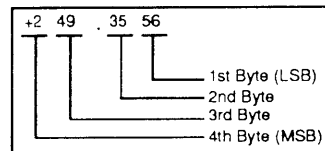

*D4 of the 4th byte represents the sign bit (0 = +, 1 = -). No bits are used for the decimal point. The location of this point is imaginary and should be signified within the device that is reading the encoder data. D5, D6, and D7 represent error codes. Refer to Chapter ① Troubleshooting & Maintenance for error code descriptions.*

# Interpreting 8-Bit Binary Output

 Helpful Hint:  
All example values are hexadecimal.

The encoder position at the time of the read is **0249.3556 = 0F9.5B08H** turns.

## First Byte (LSB)

Terminal Number	D7	D6	D5	D4	D3	D2	D1	D0
BCD Value	0	0	0	0	1	0	0	1
	Position Byte Value = 0				Position Byte Value = 8			

## 2nd Byte

Terminal Number	D7	D6	D5	D4	D3	D2	D1	D0
BCD Value	0	1	0	1	1	0	1	1
	Position Byte Value = 5				Position Byte Value = B			

## 3rd Byte

Terminal Number	D7	D6	D5	D4	D3	D2	D1	D0
BCD Value	1	1	1	1	1	0	0	1
	Position Byte Value = F				Position Byte Value = 9			

## 4th Byte (MSB)

Terminal Number	D7	D6	D5	D4	D3	D2	D1	D0
BCD Value	0	1	1	0	0	0	0	0
	Error Code (D5, D6, D7) = 3 Sign Bit (D4) = +				Position Byte Value = 0			

 Helpful Hint:  
This value will be frozen until the Data Request input returns to its high or off state.

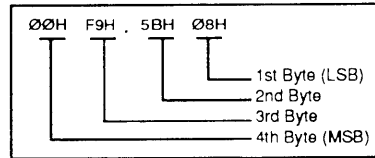

No bits are used for the decimal point. The location of this point is imaginary and should be signified within the device that is reading the encoder data. D5, D6, and D7 are used for error codes. Refer to Chapter 7 Troubleshooting & Maintenance for error code descriptions.

### CAUTION

The AR-C is accurate to 16,384 steps per rev. The last two bits in the report back will always be 0's since only 14 bits are needed for 16,384 positions (16 bits give 65,535 positions).



## 16-Bit Data Output

This section explains the process of reading a position in 16-bit segments. Wire and configure your decoder (DIP switches) as described in previous chapters. To read a position (two two-byte segments—also referred to as a *word*) from the AR-C, follow the steps below.

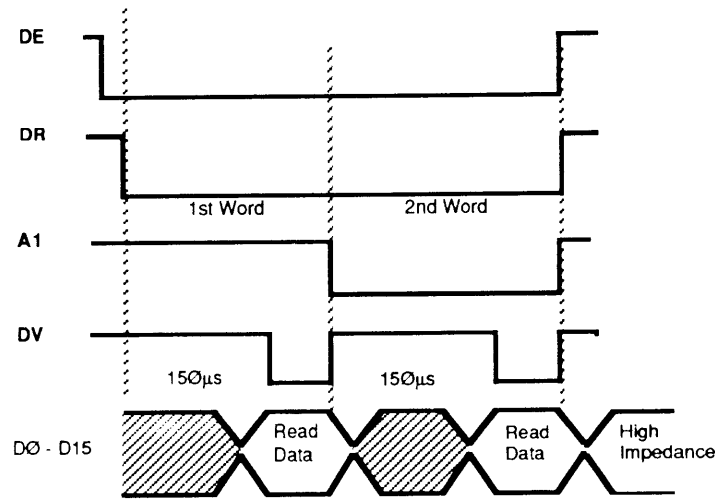

Timing—16-Bit Parallel Output

If you are using only one AR-C Encoder, ground the Device Enable (DE) input. The Device Enable input allows the selected encoder to respond to position requests. If you multiplex more than one unit, the Device Enable input will select which output the system will read. *DE must be active before you attempt to read position information.* The Data Request (DR) output must remain active during the entire data transfer (all four bytes). A1 and A0 select which segment to read. The Data Valid (DV) output signals you when the data is stable or ready.

- ① Ground the Device Enable (DE) and then Data Request (DR) inputs. Request the first byte (least significant byte—LSB) by bringing address select A1 high.
- ② Wait for the Data Valid (DV) output to go low. **Read the LSW.**
- ③ Request the most significant word (MSW) by grounding Address Select A1.
- ④ Wait for the Data Valid (DV) output to go low. **Read the MSW.**
- ⑤ Bring all of the inputs high.

## Interpreting 16-Bit BCD Output

The encoder position at the time of the read is **-254.5802** turns.

### 1st Word

Terminal Number	D15	D14	D13	D12	D11	D10	D9	D8	D7	D6	D5	D4	D3	D2	D1	D0
BCD Value	0	1	0	1	1	0	0	0	0	0	0	0	0	0	1	0
	Position Byte Value = 5				Position Byte Value = 8				Position Byte Value = 0				Position Byte Value = 2			

### 2nd Word

Terminal Number	D15	D14	D13	D12	D11	D10	D9	D8	D7	D6	D5	D4	D3	D2	D1	D0
BCD Value	0	0	0	1	0	0	1	0	0	1	0	1	0	1	0	0
	Error Code (D13, D14, D15) = No Error <b>Sign Bit (D12) = (-)</b>				Position Byte Value = 2				Position Byte Value = 5				Position Byte Value = 4			

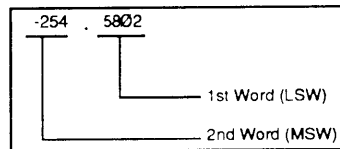

*No bits are used for the decimal point. This location is imaginary and should be fixed within the device reading the data.*

## Interpreting 16-Bit Binary Output

The encoder position at the time of the read is **-254.5802 = -FE9488** turns.

### 1st Word

Terminal Number	D15	D14	D13	D12	D11	D10	D9	D8	D7	D6	D5	D4	D3	D2	D1	D0
BCD Value	1	0	0	1	0	1	0	0	1	0	0	0	1	0	0	0
	Position Byte Value = 9				Position Byte Value = 4				Position Byte Value = 8				Position Byte Value = 8			

### 2nd Word

Terminal Number	D15	D14	D13	D12	D11	D10	D9	D8	D7	D6	D5	D4	D3	D2	D1	D0
BCD Value	0	0	0	1	0	0	0	0	1	1	1	1	1	1	1	0
	Error Code (D13, D14, D15) = No Error <b>Sign Bit (D12) = (-)</b>				Position Byte Value = 0				Position Byte Value = F				Position Byte Value = E			

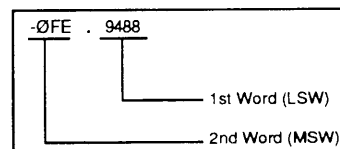

*No bits are used for decimal point. This location is imaginary and should be fixed within the device reading the data.*

### CAUTION

The AR-C is accurate to 16,384 steps per rev. The last two bits in the report back will always be 0's since only 14 bits are needed for 16,384 positions (16 bits give 65,535 positions).

## Using Multiple Units in Parallel Output Mode

If you intend to use more than one decoder in parallel output mode (8-bit or 16-bit), you can *multiplex* the parallel outputs. Multiplexing allows you to share common data and control signals between decoders. This reduces the number of inputs and outputs that your PLC uses. You may multiplex as many units as your PLC can handle.

You can read only one decoder at a time. Each decoder must have its own distinct Device Enable (DE) input from the PLC. Refer to your PLC's user guide for specific information on I/O capabilities and programming.

Before you begin to wire your multiplex configuration with the decoders, you must remove resistor packs **RN10** and **RN11** from all but one decoder in the multiplex configuration (the last unit). For example, if you multiplex 5 units, remove resistor packs **RN10** and **RN11** from units 1-4 and keep them in unit 5. Removing these resistors prevents the output transistors from saturating due to low impedance.

The figure below illustrates the wiring configuration for decoder multiplexing. Before wiring the units, be sure that each unit complies with the recommendations previously discussed (distinct I/O on PLC and removal of resistors on all but one unit).

 **Helpful Hint:**  
The decoder also has a Data Valid (DV) output. The PLC can handshake with the decoder using the decoder's DV output and Device Enable (DE) input.

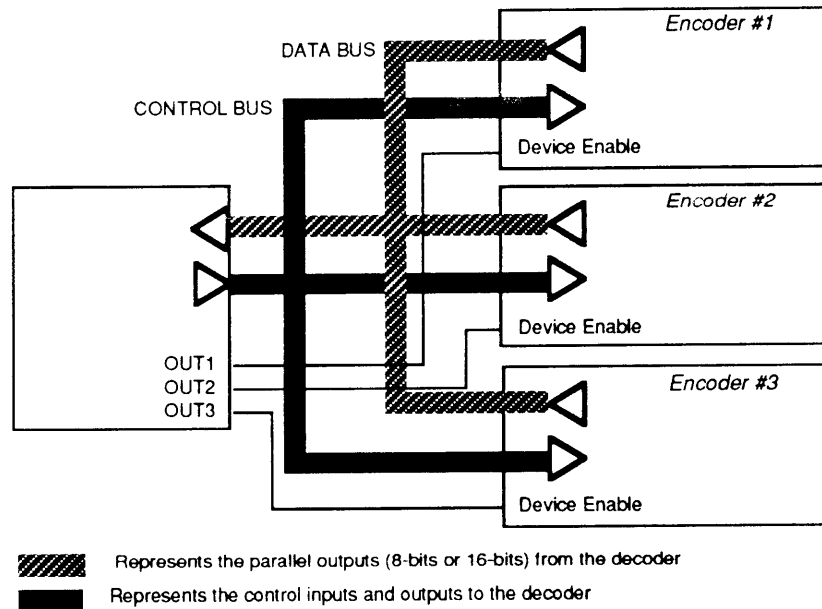

*Multiplexing Configuration*

## Offset Pushbutton

The default position format is a binary number in the range from zero (zero turns) to the maximum count (512 turns) with no position offset. To add flexibility, you may select another absolute encoder position to be zero by pushing the *offset pushbutton* on the decoder box.

This pushbutton is accessible with a pencil through a hole in the front panel. This hole is covered with a plastic plug, which must be removed. After pressing the button, the current absolute encoder position is saved in nonvolatile memory. When set, this saved position is subtracted from each absolute position before it is transmitted to the indexer.

A remote switch can be installed to the ZERO input on the decoder box to zero the position. When the ZERO pin is connected to ground, an offset of zero will be selected. The ZERO pin is located between the OPTO- and GND pins on the front panel (it is left blank). Jumper JU6 must be installed properly for this input to be acknowledged.

To select an offset other than zero, move your rotary motion system with the AR-C encoder attached to the desired (*home*) position and press the offset pushbutton switch after motion has stopped. The red **STATUS** LED will illuminate for approximately 2 seconds after detection of the depressed pushbutton switch. **To save the new position offset in EEPROM, you must release the pushbutton before the red STATUS LED turns off.**

To clear the position offset, keep the pushbutton depressed until the red **STATUS** LED on the decoder's front panel turns off about 2 seconds later. *This procedure is only applicable when the AR-C is operated with the Model 4000 (4000 mode).*



## Hardware Reference

The information in this chapter will enable you to do the following:

- ❑ Determine the dimensions of the AR-C and its decoder box.
- ❑ Determine the mechanical, environmental, and electrical specifications of the AR-C and its decoder box.
- ❑ Determine the proper switch and jumper settings for the AR-C.

### Dimensional Specifications

The following section contains AR-C dimensional information.

#### Decoder Box Dimensions

Refer to the following figure for decoder box dimensions.

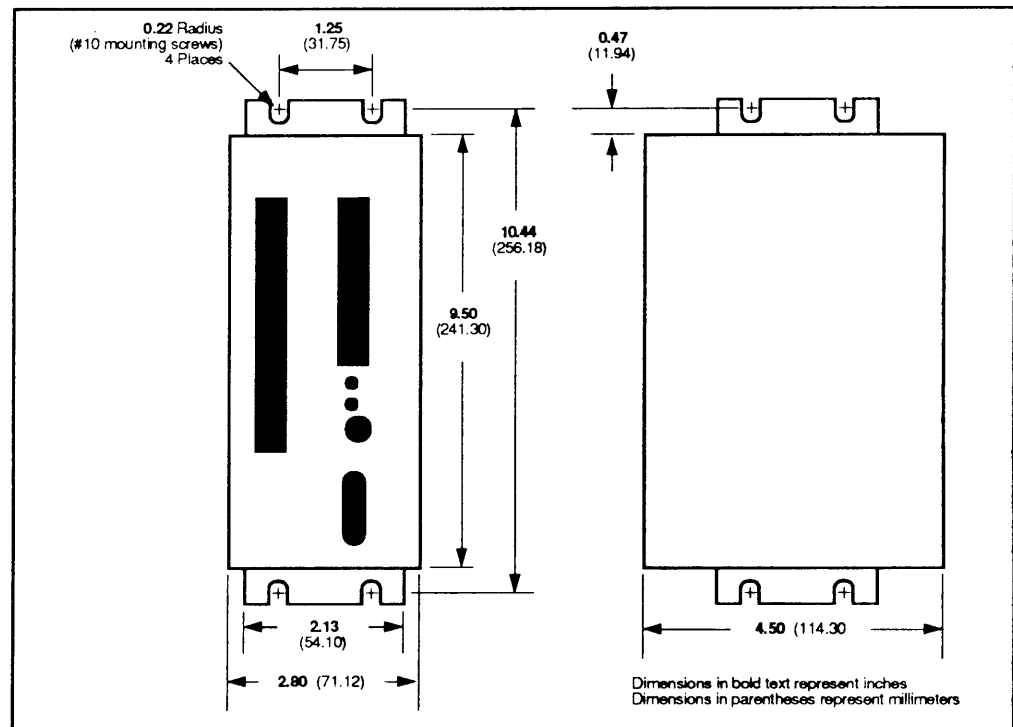

# AR-C Encoder Head Dimensions

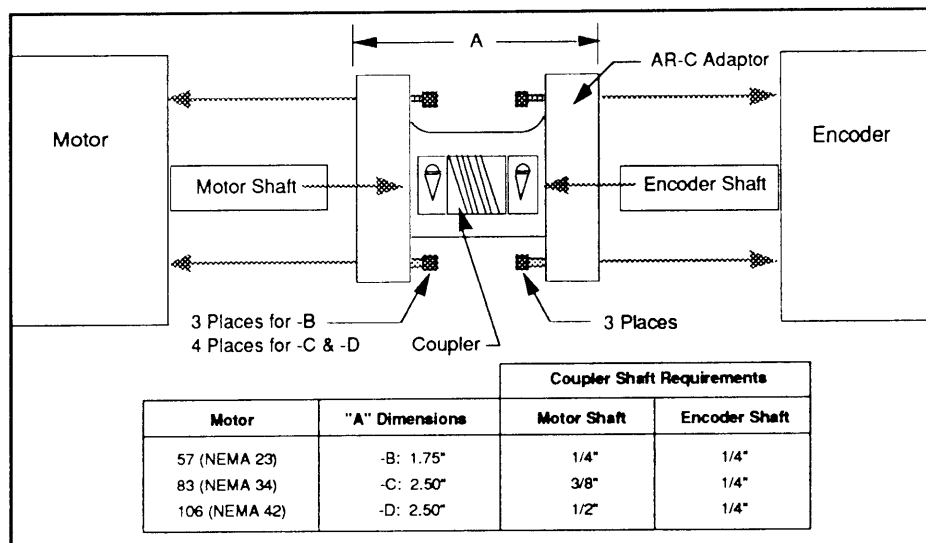
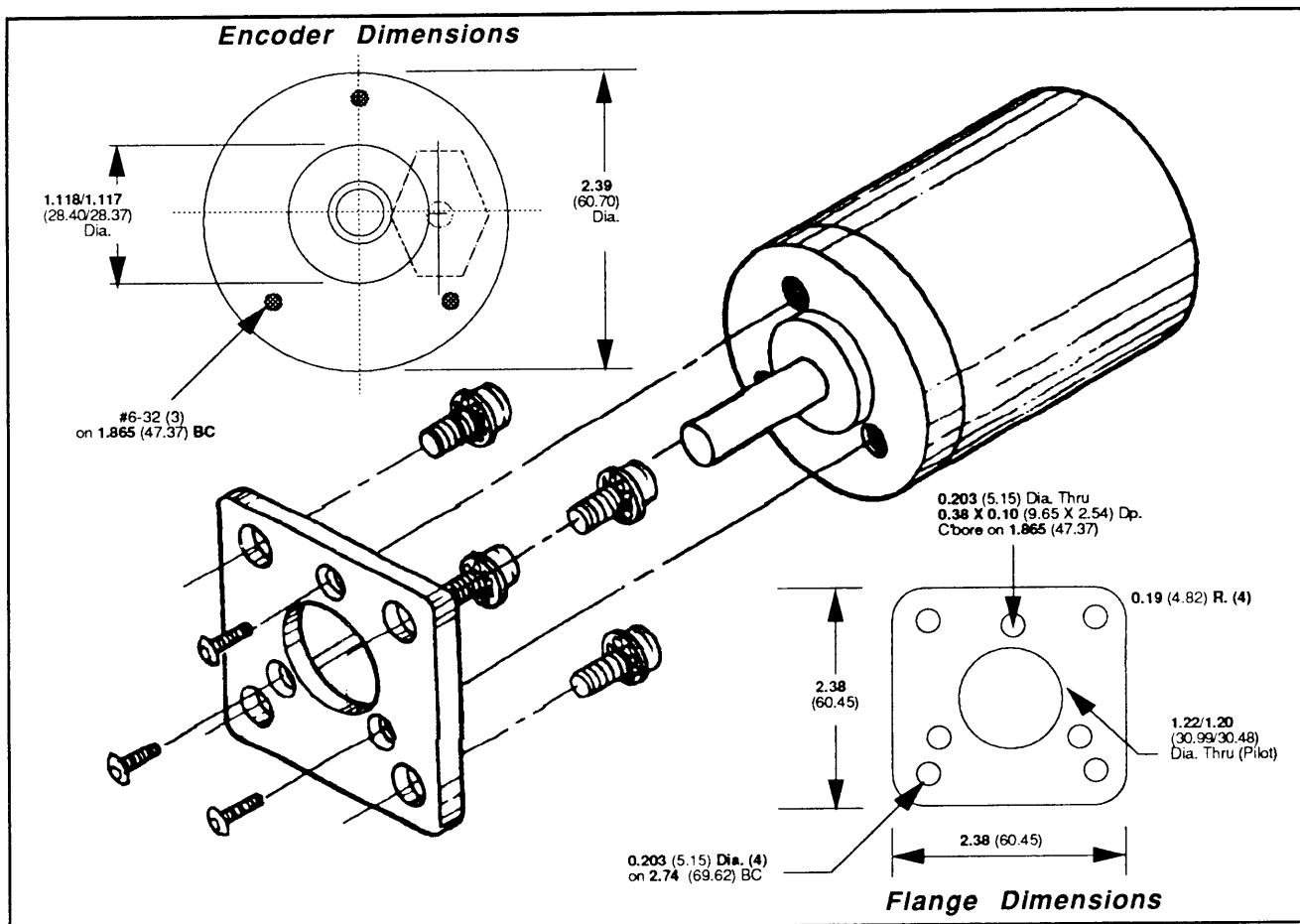

## Mechanical Specifications

Use the following table as a quick reference for AR-C mechanical specifications.

Mechanical Parameter	AR-C Specification
Resolution	1,024 or 16,384 positions per revolution (ppr)
Range	Up to 8,388,608 discrete positions for 512 turns
Accuracy	@ 16,384 ppr: $\pm 0.0002$ rev. (5.3 arc minutes) @ 1,024 ppr:
Repeatability	Less than 0.000061 rev.
Inertia	0.03 oz-in <sup>2</sup> (0.387 gm-cm <sup>2</sup> )
Torque	Friction Torque: 1.5 oz-in (0.0208 gm-cm)
Maximum Speed	1,000 rpm at full resolution
Housing Material	Anodized aluminum
Shaft Material	#303 stainless steel
Rack Material	N/A
Encoding Disk Material	Metal
Bearing Rating	ABEC 5
Shaft Loading	Radial 3 lbs; Axial 1 lb
Seal Type	Fluorocarbon
Housing Weight	1.0 lb (0.45 Kg)

## Electrical Specifications

Use the following table as a quick reference for AR-C electrical specifications.

Electrical Parameter	Specification
Input Power	Decoder Box: 120VAC, $\pm 10\%$ , 0.5 A, 50/60 Hz
Parallel Output	TTL Compatible Options: 8- or 16-Bit; Binary or BCD
Serial Interface	RS-232C or RS-422C/485C Maximum Cable Length: RS-422/485 is 4,000'; RS-232 is 20'
Cable Length (encoder to decoder)	10' Standard; Maximum is 20' (optional 20' cable available)

## I/O Circuit Descriptions

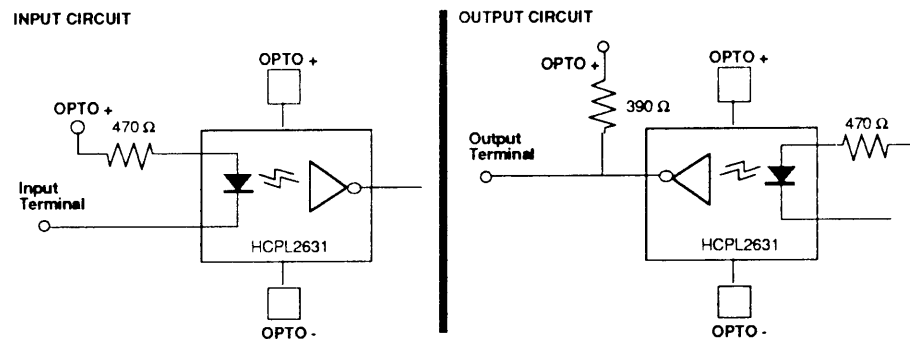

*OPTO Isolator Circuits for Inputs and Outputs*

## Environmental Specifications

Use the following table as a quick reference for AR-C mechanical specifications.

Environmental Parameter	Specification
Operating Temperature	32°F to 122°F (0°C to 50°C)
Storage Temperature	-22°F to 185°F (-30°C to 85°C)
Humidity	0 to 95% (non-condensing)
Fluid Protection	AR-C: Fluids can seep through cable hole — protect with splash guard or some other protective device



## Default DIP Switch Settings

Use the following table as a quick reference for the decoder box DIP switch settings. Refer to *Chapter 2 Getting Started* for information on how to open the decoder box.

Switch #	Setting	Description	Comments
#1	ON	Selects RS-422/485 serial communication	None
	OFF*	Selects RS-232 serial communication	
#2	ON	Half-Duplex: transmit & receive data (not simultaneously in both directions) over two wires	None
	OFF*	Full-Duplex: transmit & receive data simultaneously over 4-wire or 3-wire interface	
#3	ON	Encoder count increases when encoder head rotates in CW direction	Switch #3 does not affect incremental encoder output.
	OFF*	Encoder count increases when encoder head rotates in CCW direction	
#4	ON*	16-bit parallel communication	None
	OFF	8-bit parallel communication	
#5	OFF*	Stand-alone operation mode	None
#6	ON*	Operate as a multi-turn absolute encoder	None
	OFF	Operate as a single-turn absolute encoder	PB & PR command responses are shortened
#7 — #8	OFF* — OFF*	Standalone operation mode	None

\* Factory default settings

DIP Switch Settings

Refer to *Chapter 2 Getting Started* for setting to be selected in common applications.

### Standalone Mode (RS-232C Serial Interface)

The following tables show the default AR-C settings for the decoder box DIP switches and jumpers in standalone mode.

DIP Switch	Default Position	Function
S3-1	OFF	RS-232C
S3-2	OFF	Full-Duplex
S3-3	OFF	CCW is increasing count
S3-4	ON	16-bit parallel
S3-5	OFF	Hexadecimal reporting
S3-6	ON	Multi-turn
S3-7 - S3-8	OFF - OFF	Stand-alone mode (#7 and #8 both must be off).

### SX Indexer Mode (RS-422C Serial)

The following table shows the switch definitions for DIP switch S3 in the decoder box when the decoder box is in SX Drive/Indexer mode.

Switch #	Setting	Function
S3-1	-----	No function
S3-2	-----	No function
S3-3	OFF	CCW is increasing count
	ON	CW is increasing count
S3-4 - S3-5	OFF — OFF	16,384 positions/revolution
	ON — OFF	8,192 positions/revolution
	OFF — ON	4,096 positions/revolution
	ON — ON	2,048 positions/revolution
S3-6	-----	No function
S3-7 - S3-8	ON — OFF	SX mode

## AX-A Indexer Mode (RS-485C Serial)

The following table shows the switch definitions for DIP switch S3 in the decoder box when the decoder box is in AX-A Indexer mode.

Switch S3-	Setting	Function
S3-1	Must be ON	RS-422/485
S3-2	Must be ON	Half-duplex
S3-3	Must be ON	CW is increasing count
S3-4	-----	No function
S3-5	Must be ON	Hexadecimal reporting
S3-6	Must be ON	Multi-turn
S3-7 — S3-8	OFF — ON	AX-A mode

## JSI, Model 500, and Model 4000 Indexer Mode (Parallel Interface)

The following table shows the switch definitions for DIP switch S3 in the decoder box when the decoder box is in the JSI, Model 500, and Model 4000 Indexers mode.

Switch #	Setting	Function
S3-1	—	No function
S3-2	—	No function
S3-3	OFF	CCW is increasing count
	ON	CW is increasing count
S3-4 — S3-5	OFF — OFF	16,384 positions/revolution
	ON — OFF	8,192 positions/revolution
	OFF — ON	4,096 positions/revolution
	ON — ON	2,048 positions/revolution
S3-5	—	No function
S3-6	Must be ON	Multi-turn
S3-7 — S3-8	ON — ON	JSI, Model 500 and Model 4000 mode

# Jumper Settings

Use the following table as a quick reference for the decoder box jumper settings.

Jumper	Default Function	Non-Default Function
JU1	Standard bias voltage to encoder head	Increase bias voltage to encoder head
JU2	Logic ground is connected to Earth ground	Logic ground is floating
JU3	Standard bias voltage to encoder head	Increase bias voltage to encoder head
JU4	Terminate RS-422/485 with a 100 Ω resistor (JU4 and JU5 must be set the same: either both on or both off)	Terminate RS-422/485 with a 50 Ω resistor (JU4 and JU5 must be set the same: either both on or both off)
JU5		
JU6	Zero Input	Analog Output

### AR-C Jumper Functions

**Helpful Hint:** Facing the front panel, the jumpers are on the right side of the unit.

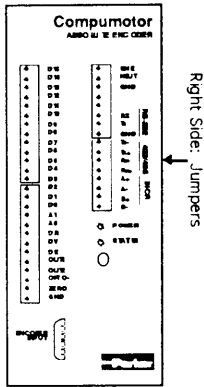

The figure below is a circuit diagram of jumpers JU4 and JU5. These jumper settings may be changed for RS-422/485 applications requiring special considerations.

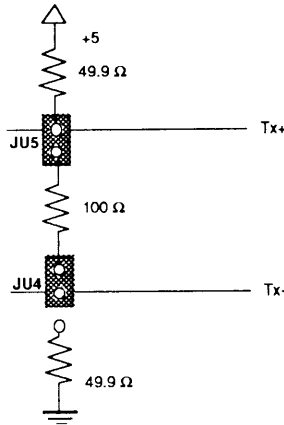

### WARNING

Only special applications require the AR-C's jumper settings to be modified. Compumotor should be consulted before making any modifications. Unauthorized modification may damage your application and void your product's warranty.

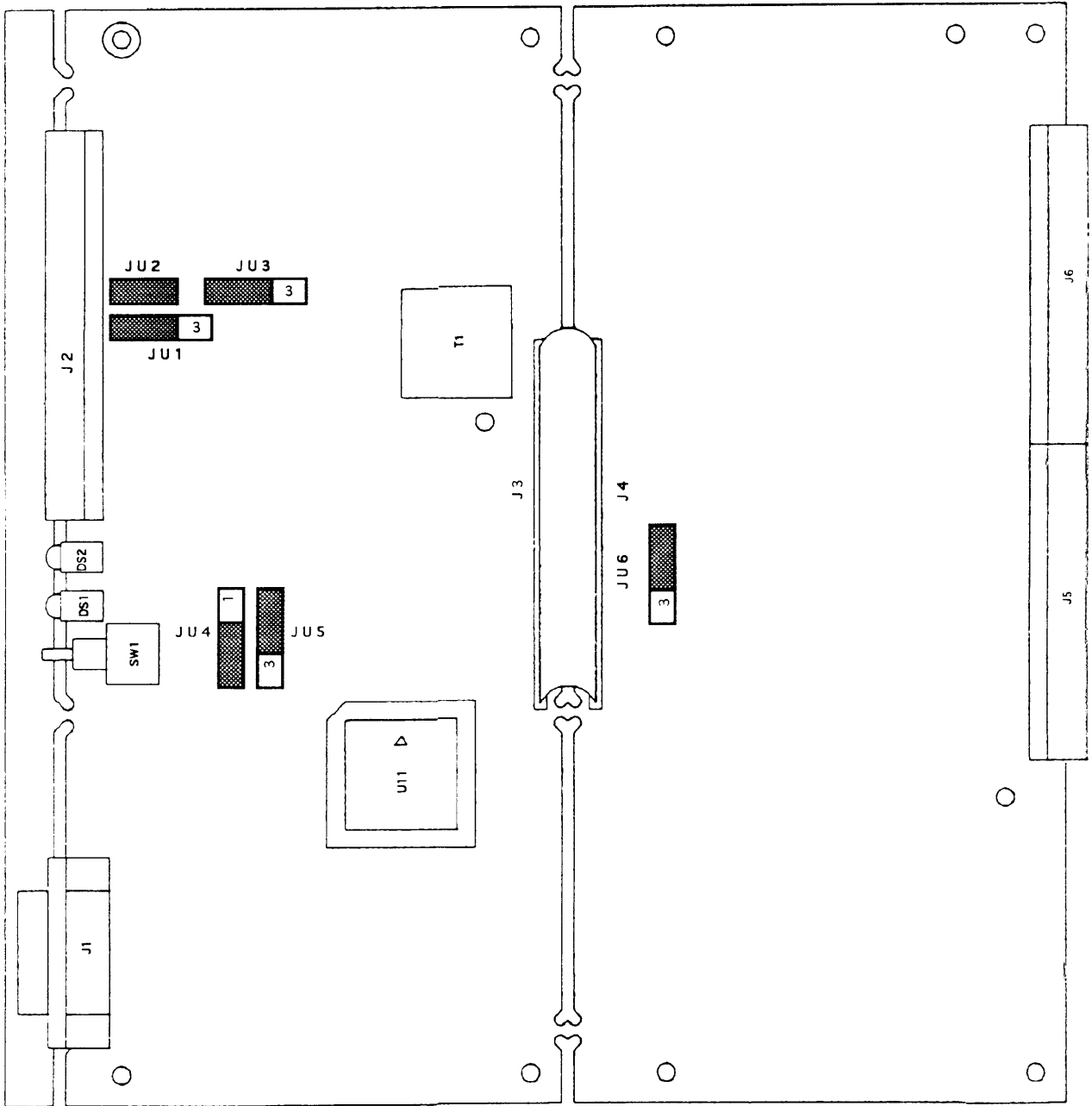

AR-C Jumper Locations



## Software Reference

Use this chapter as a reference for the function, range, default, and sample use of each command

### Command Format Description

The AR-C allows you to communicate over the serial interface with several software commands. This section describes the format of the command descriptions in this chapter. The numbered arrows refer to the numbered sections below the drawing.

**① PB** **② Binary Position Report** **③ Version Y**

<b>Type</b>	Status	<b>⑤ Attributes</b>
<b>Syntax</b>	aPBn	[ ] Buffered
<b>④ Units</b>	n = revolutions	[ ] Device Specific
<b>Range</b>	None	[ ] Saved Independently
<b>Default</b>	None	[ ] Saved in Sequences
<b>Response</b>	4 bytes of binary data and a carriage return	
<b>See Also</b>	SS, SP	

**⑥** When you enter this command, the AR-C reports the encoder's current position in binary format. This position will be offset and scaled by programmed parameters. The position report will not appear in ASCII format, therefore you must read the response as a binary report. If the AR-C is searching for ASCII characters, the unit's response will be in the form of ASCII characters that correspond to the binary pattern.

<b>⑦ Command</b>	<b>Description</b>
ØPB	ØØØØØØØØB, ØØØØØØØØB, 1ØØ11111B, 1Ø111ØØØB, ØØØ111Ø1B,

#### ① Command Identifier

The letter or letters used to represent the command.

#### ② Command Name

This is the actual command name.

### ③ Version

The revision of software in the AR-C when the described command was first introduced or last modified. If the revision level of the software you are using is equal to or greater than the revision level listed here, the command is available in your unit. You can determine the level of software in your AR-C by issuing the Revision Level (RV) command.

### ④ Characteristics

The following sections describe the main characteristics of the command.

#### Type

This portion of the box contains the command's type. The four command types are listed below.

**Set-Up:** These commands define Set-Up conditions for the application. Set-Up commands include the following types of commands:

- Homing (go home acceleration and velocity, etc.)
- Input/Output (limits, scan time, in-position time, etc.)
- Tuning (servo or position tracking)
- General (set switches, return to factory settings, etc.)

**Programming:** Programming commands affect programming and program flow. For example, trigger, output, all sequence commands, quote, time delays, pause and continue, enable and front-panel, loop and end loop, line feed, carriage return, and backspace.

**Status:** Status commands respond (report back) information.

**Motion:** Motion commands affect motor motion (for example, acceleration, velocity, distance, go home, stop, direction, mode, etc.)

#### Syntax

This field shows the syntax for the command. AR-C commands use the following generic syntax: `a c s d`

**Variable a** This variable is the device address. If the address is optional it is shown in angle brackets: `<d>`. Only commands that require the AR-C to send a response require a device address. All commands may use a device address to designate which unit on a daisy chain is intended to receive the command.

**Variable c** This variable is the command identifier, which is one or more letters.

**Variable s** This variable represents a sign. A sign is not allowed for all commands. The **s** is not shown in the syntax if not allowed.

**Variable d** This variable is the end of command delimiter. This is always required and is not shown in the following descriptions for clarity. The delimiter may be a space character or a carriage return.

#### Units

This field describes what unit of measurement the parameter in the command syntax represents.

#### Range

This is the range of valid values that you can specify for **n** (or any other parameter specified).

#### Default

The default setting for the command is shown in this box. A command will perform its function with the default setting if you do not provide a value.

#### Response

The response to the command is shown in this box. Status commands report a condition in the indexer. Status commands do not affect the status they read.

Commands that set parameters report the parameters when the command is issued without a parameter. For example, **A100** sets the acceleration to 100 rps, but **1A** returns the current setting. **Note:** To receive a response, a device address is required.

See Also Commands that are related or similar to the command described are listed here.

## ⑤ Attributes

Each command has attributes as shown below.

**Attributes**  
 Buffered  
 Device Specific  
 Saved Independently  
 Saved in Sequences

### Buffered

If the Buffered box is checked the command is buffered. If it is not checked the command is acted on immediately. Buffered commands are executed in the order they are received. An internal buffer, or storage area, holds the commands in a queue until the previous command has been executed.

Immediate commands are executed as they are received. Immediate commands are executed even if the command buffer has commands in it. For example, the Stop (S) command is immediate. When a Stop command is received the motor is stopped as soon as the command is received. The AR-C does not process the commands in its command buffer before stopping the motor.

### Device Specific

If the Device Specific box is checked the command requires a device identifier. If it is not checked the command may be used with or without a device identifier. Status commands are generally device specific. Device specific commands have a syntax description with an **a** by itself before the command. If it is not device specific the command syntax description has a **<a>** in angle brackets before the command.

### Saved Independently

If the Saved Independently box is checked, the parameter controlled by the command is saved with the Save Parameters (SS) command. This differs from commands that may only be saved in sequences and those that are never saved. If neither the Saved Independently nor the Saved in Sequences box is checked, the command is never saved.

### Saved in Sequences

If the Saved in Sequences box is checked, the command will be saved only if it is in a sequence and you issue the Save Parameters command (SS). If neither the Saved Independently nor the Saved in Sequences box is checked, the command is never saved.

## ⑥ Description

A description of the command appears in this area along with any special considerations you should know about.

## ⑦ Example

An example of how to use the command appears in this area. The left column contains the commands you would issue to the AR-C. The right column contains descriptions of what the commands do in the program.



# Alphabetical Command Listing

---

## AR Automatic Position Report

Version All

**Type** Status  
**Syntax** aARn  
**Units** n = Enable or Disable  
**Range** n = 0 (Disable) or 1 (Enable)  
**Default** Last Saved Value  
**Response** Reports Position Continuously  
**See Also** SS, SP, PR

**Attributes**  
[ ] Buffered  
[X] Device Specific  
[X] Saved Independently  
[ ] Saved in Sequences

This command enables/disables the automatic serial position report. When enabled, the position will be updated approximately 12 times each second. If you enter 0, you will disable the function. If you enter 1, you will enable the function. You can only use this command while you are in the serial mode (RS-232C & RS-422/485). If your application requires daisy chaining, you **must** disable the Automatic Report function (position reports do not contain addresses). Once you enable this function, it reports position information continuously until you issue aAR0 to disable the function.

<u>Command</u>	<u>Description</u>
> 0AR1	Enables automatic position report

---

## DS Display DIP Switch Settings

Version C2

**Type** Status  
**Syntax** aDS  
**Units** None  
**Range** None  
**Default** None  
**Response** \*00\_10\_11\_00  
**See Also**

**Attributes**  
[ ] Buffered  
[X] Device Specific  
[ ] Saved Independently  
[ ] Saved in Sequences

The DS command displays the current DIP switch settings. The AR-C has eight DIP switches. Each digit in the command response corresponds to a DIP switch status. In the response, 0 = off and 1 = on.

<u>Command</u>	<u>Response</u>
0DS	*00_10_11_00 (DIP Switch Settings: #1 = off, #2 = off, #3 = on, #4 = off, #5 = on, #6 = on, #7 = off, #8 = off)

---

## PB Binary Position Report

Version Y

**Type** Status  
**Syntax** aPB  
**Units** None  
**Range** None  
**Default** None  
**Response** 4 bytes of binary data [cr] [lf]  
**See Also** AR, PR

**Attributes**  
[ ] Buffered  
[X] Device Specific  
[ ] Saved Independently  
[ ] Saved in Sequences

When you enter this command, the AR-C reports the encoder's current position in binary format. The first three bits are error information. This position will be offset and scaled by programmed parameters. If the AR-C is operated in Single-turn mode, the response will be shortened to three bytes with the first containing only error information.

<u>Command</u>	<u>Response</u>
> 0PB	<i>If you attempt to display this response, unfamiliar characters may appear (e.g., ∞, @, :.). In some cases, the characters may not visible.</i>

## PR

## Position Report

Version Y

**Type** Status  
**Syntax** aPR  
**Units** None  
**Range** None  
**Default** None  
**Response** Ø\_25458Ø2 [cr] [lf] (*Response Range = 0.0000 to 511.9999*)  
**See Also** AR, PB

**Attributes**  
 Buffered  
 Device Specific  
 Saved Independently  
 Saved in Sequences

This command reports the current absolute position. Upon execution, the AR-C provides formatted and scaled encoder position data over the serial port. The encoder's position is reported with seven or four digits. If the AR-C is operated in Multi-turn mode, the position response will be given in seven digits. If the AR-C is operated in Single-turn mode, the position response will be given in four digits.

The last four digits represent the fraction of a revolution that the encoder is located at. The first three digits represent the absolute number of encoder turns. The report is given in one of the following formats, depending on how you set the **SP** command. Refer to *Chapter 7 Troubleshooting & Maintenance* for error code descriptions.

**SPØ** Response is in hexadecimal format  
**SP1** Response is in decimal format (no decimal point)  
**SP2** Response is in decimal format (decimal point automatically inserted)

### Command

### Response

> ØPR

Ø\_25458Ø2 (Ø = an error code, \_ = a space, and the seven-digit number represents the current absolute encoder position). The space will contain a minus sign [-] if you create a position offset (**SO** command) and the encoder rotates beyond the new zero point in the decreasing counts direction.

## RP

## Report Set-Up Parameters

Version Y

**Type** Status  
**Syntax** aRP  
**Units** None  
**Range** None  
**Default** None  
**Response** See Table Below  
**See Also** None

**Attributes**  
 Buffered  
 Device Specific  
 Saved Independently  
 Saved in Sequences

This command reports the current set-up parameters. The report is sent via the serial port in ASCII decimal format only.

Cmd	Decoder Response	Description
ØRP	SN=Ø	Device Address
	SP=ØØ	Data Output (first)
	SE=Ø1	Enable Error Code
	AR=ØØ	Auto report
	SD=ØØ	Direction
	SM=ØØ	Full/Half Duplex
	SO=ØØØØØØØØ	Offset
	SF=Ø1ØØØØ	Scale Factor
	SL=ØØØØØØØØ	Output 2 pos
	SI=ØØ	Low/High Resolution

*These represent factory default settings*

All values except SN have an extra "Ø" preceding the user-entered values.

---

## RV Revision Level

**Type** Status  
**Syntax** aRV  
**Units** None  
**Range** None  
**Default** None  
**Response** \*92-11855-A  
**See Also** PR

**Version** Y

**Attributes**  
[ ] Buffered  
[x] Device Specific  
[ ] Saved Independently  
[ ] Saved in Sequences

The **RV** (Revision) command provides the current software revision level. You may want to record this information in your own records for future use. This type of information is especially useful when directing questions about software to Parker Compumotor's Applications Department.

<u>Command</u>	<u>Description</u>
> ØRV	*92-11855-A

---

## SE Enable Error Checking

**Type** Status  
**Syntax** aSEn  
**Units** n = Enable or Disable  
**Range** n = Ø (Disable) or 1 (Enable)  
**Default** Last Saved Value  
**Response** See Table Below  
**See Also** RP, SS

**Version** Y

**Attributes**  
[ ] Buffered  
[x] Device Specific  
[x] Saved Independently  
[ ] Saved in Sequences

This command enables/disables the error checking function. If you enter **1**, you will enable error checking. If you enter **Ø**, you will disable error checking. The error code is the most significant (first) digit of the position report in serial mode, and the two most significant bits (first two) in parallel mode. Four possible error codes may be reported. These error codes are described in *Chapter 7 Troubleshooting & Maintenance*.

### Valid Error Codes

- Ø No Error
- 1 Not ready for read
- 2 EEPROM Failure
- 3 Roll-over error or data error
- 5 High-resolution error
- 8 Encoder head disconnected

<u>Command</u>	<u>Description</u>
> ØSE1	Enables error checking

---

## SF Define Scale Factor

Version Y

**Type** Set-Up  
**Syntax** aSFn  
**Units** n = Scale Factor  
**Range** 00001 - 29999  
**Default** Last Saved Value  
**Response** None  
**See Also** RP, SS

**Attributes**  
[ ] Buffered  
[x] Device Specific  
[x] Saved Independently  
[ ] Saved in Sequences

This command scales the encoder position output in desired units. This is multiplied by the present position before a position output is reported. There is an imaginary decimal after the first number.

<u>Command</u>	<u>Description</u>
> 0SF05000	Defines the scale factor as 0.5
> 0SF20000	Defines the scale factor as 2.0000

---

## SI Define Resolution

Version Y

**Type** Set-Up  
**Syntax** aSIn  
**Units** n = Resolution  
**Range** 0 = Low Resolution, 1 = High Resolution  
**Default** 1  
**Response** None  
**See Also** None

**Attributes**  
[ ] Buffered  
[x] Device Specific  
[x] Saved Independently  
[ ] Saved in Sequences

This command sets the resolution of the encoder head.

- SI0 = Low resolution (AR-C = 1,024 steps/rev)
- SI1 = High resolution (AR-C = 16,384 steps/rev)

---

## SL Define Output 2 Position

Version C4

**Type** Set-Up  
**Syntax** aSLn  
**Units** n = Output 2 Position (rev)  
**Range** 0 - 255.99  
**Default** Last Saved Value  
**Response** None  
**See Also** RP, SS

**Attributes**  
[ ] Buffered  
[x] Device Specific  
[x] Saved Independently  
[ ] Saved in Sequences

The SL command allows users to select a 256 step region (0.0156 rev) as a "home" region. When the encoder head is within this region, Output #2 will turn on (become active).

<u>Command</u>	<u>Description</u>
> 0SL02000	Output 2 will turn on (become active) between positions 20.0000 and 20.0156 revs.

*If you select a fraction of a rev. (e.g., 0SL02015), the selected setpoint will be contained within the active region (i.e., 0.0156 region). The active region may start before the actual setpoint.*

---

## SN Define Device Address

Version Y

**Type** Set-Up  
**Syntax** aSNn  
**Units** n = Device Address  
**Range** Ø - 9, A - F  
**Default** Last Saved Value  
**Response** None  
**See Also** RP

**Attributes**  
[ ] Buffered  
[X] Device Specific  
[X] Saved Independently  
[ ] Saved in Sequences

This command defines the device address of each unit. Use this command when more than one unit is connected to the same serial port. These addresses are valid for daisy chain and multi-drop configurations. The maximum address capability is 16 units (Ø - 9, A - F). Only four units may be configured on an RS-232C daisy chain, however, the units may be assigned any valid address (i.e., the addresses do not have to be sequential—1, 2, 3, 4).

### Command

> ØSN5

### Description

Defines new address as 5 (address was previously Ø)

---

## SO Define Position Offset

Version Y

**Type** Set-Up  
**Syntax** aSOnnnnnnn  
**Units** n = Turns  
**Range** Ø - 255, A  
**Default** Last Saved Value  
**Response** None  
**See Also** RP, SS

**Attributes**  
[ ] Buffered  
[X] Device Specific  
[X] Saved Independently  
[ ] Saved in Sequences

This command has an imaginary decimal point after the third digit. It allows you to establish an absolute zero point without turning the shaft until position zero is present. The system compares the value that you enter to the actual position before you entered the command. The difference between the two represents the offset. If you enter **A** after the command, the offset will be reset to Ø. The offset value that you enter after ØSO becomes the new encoder position corresponding to the present mechanical encoder position. *The offset value that you enter cannot be greater than the current encoder value or 2,550,000. Values beyond this range will elicit invalid data from the system.*

### Command

> ØSOØ

### Description

Defines present position as zero (0)

## SP

## Define Data Output Format

Version Y

Type	Set Up
Syntax	aSPn
Units	n = Data Output Format
Range	0 = Binary/Hex, 1 = BCD/Decimal, 2 = Enable Decimal
Default	0
Response	None
See Also	SS

### Attributes

[ ]	Buffered
[x]	Device Specific
[x]	Saved Independently
[ ]	Saved in Sequences

This command defines the format of position output data. Zero (0) defines the data format to be binary for parallel output and ASCII hexadecimal for serial output. If you enter 1, you will define the data format as BCD for parallel output and ASCII decimal for serial output. If you enter 2, the decimal point will be enabled at the fourth place from right. *SP0 must be selected to enable DIP switch 5 to function. If SP0 is not selected, SP1 and SP2 will override the DIP switch 5 setting.*

- SP0** defines the data to be binary for the parallel port and ASCII hexadecimal for the serial port.
- SP1** Defines the data as BCD for parallel output and ASCII BCD for serial output.
- If you enter **SP2** a decimal point is inserted before the last 4 digits of the ASCII BCD data for serial output.

### Command

### Description

> 0SP0 Enables serial output format as ASCII hexadecimal

## SS

## Save Parameters

Version Y

Type	Set Up
Syntax	aSS
Units	None
Range	None
Default	None
Response	None
See Also	None

### Attributes

[ ]	Buffered
[x]	Device Specific
[ ]	Saved Independently
[ ]	Saved in Sequences

Saves all currently defined set-up parameters in non-volatile memory. All commands previously entered will be lost if you do not execute this command.

### Command

### Description

> 0SS Saves all current set-up parameters

## Z

## Software Reset

Version Y

Type	Set Up
Syntax	Z
Units	None
Range	None
Default	None
Response	None
See Also	None

### Attributes

[ ]	Buffered
[ ]	Device Specific
[ ]	Saved Independently
[ ]	Saved in Sequences

The **Z** (Reset) command is equivalent to cycling power to the decoder. This command returns all internal settings to the last values saved with the **ss** command. This command does not require a device address.

### Command

### Description

> Z Resets any and all decoders on the system



---

---

## Troubleshooting & Maintenance

The information in this chapter will enable you to do the following:

- isolate and resolve system hardware problems.

### Troubleshooting

---

This section provides methods to identify and resolve possible encoder-related system problems.

#### RS-232C Communications

If you are having problems communicating with the indexer, check the following key areas to troubleshoot the communications interface.

- Ensure that the DR input for parallel communication is **not** grounded.
- Verify that the DIP switches are set properly (refer to *Chapter 2 Getting Started*)
- Try switching the receive and transmit wires on either the host or peripheral if you fail to successfully communicate. The wires may be switched.
- Configure the host and peripheral to the same baud rate, number of data bits, number of stop bits, and parity (refer to *Chapter 2 Getting Started* for the proper values for these parameters).
- If you receive double characters, for instance typing **A** and receiving **AA**, your computer is set for half duplex. Change the setup to full duplex.
- Use DC common or signal ground as your reference, *not* earth ground.
- Cable lengths should not exceed 20 ft. unless you are using some form of line driver, optical coupler, or shield. As with any control signal, be sure to shield the cable to earth ground at one end only.
- To test your terminal or terminal emulation software for proper three-wire communication, unhook your peripheral device and transmit a character. You should not receive an echoed character. If you do, you are in Half-duplex mode. Short the host's transmit and receive lines and send another character. You should receive the echoed character. If not, consult the manufacturer of the host's serial interface for proper pin outs.



**Helpful Hint:**  
Some serial ports require handshaking. You can then establish three-wire communication by connecting RTS to CTS (usually pins 4 and 5) and DSR to DTR (usually pins 6 to 20).

**Helpful Hint:**  
After checking your computer, enter **[cr]ØRP**. The system should respond with set-up parameters. The reason for entering a **[cr]** before the command is to clear the buffer before you enter the command.

- ❑ If the computer is looking for handshaking signals, you may need to install jumper wires at the terminal end to disable this function. Since the pin-out from various computers are different, refer to your computer's operator's manual for instructions on how to disable the handshaking function. Most computers, however, use the pins shown in the figure below to install jumpers. For more detailed information on this topic, refer to *RS-232C Made Easy*, published by Prentice-Hall, Inc.

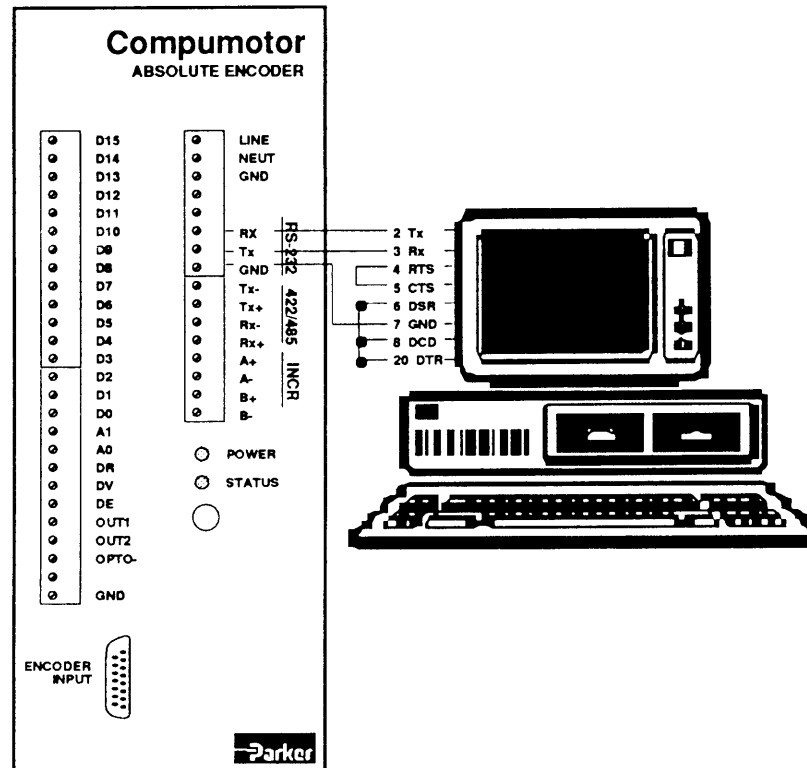

Disabling the Handshaking Function

- ❑ If you still do not received an echo, use another computer to complete this test (determine if the serial port is not compatible with the system or if it is malfunctioning). If this is not possible, contact our Application Department at (800) 358-9070.
- ❑ If you receive echoed characters, but no parameters are reported, the address preceding the **RP** command may be something other than **Ø**. The only way to find the proper address is to try all of the numbers in range (**ØRP** - **FRP**).

## RS-422/485 Communications

If you are having problems communicating with the indexer, check the following key areas to troubleshoot the communications interface.

- ❑ Ensure that the DR input for parallel communication is **not** grounded.
- ❑ Verify that the DIP switches are properly set (as shown in *Chapter 2 Getting Started*). Double check the system connections (review *Chapter 3 Installation*). Type **ØRP**.

The response to this command will help you to determine if set-up parameters are reported. If no data is reported, there may be a compatibility problem with the interface circuit that you are using. Since there is no echo with RS-422/485, the next step is to verify that the interface circuit is operating with the following parameters:

- Baud Rate: 9,600
- Start/Stop Bit(s): 1
- Data Bits: 8
- Parity: None

- ❑ If nothing is received or command is echoed, the address preceding the **RP** command may be something other than  $\emptyset$ . The only way to find the proper address is to try all of the numbers in range ( $\emptyset$ RP - FRP).
- ❑ Verify terminal operation by removing RS-422/485 connections from the AR-C. Connect Tx+ to Rx+ and Tx- to Rx-. All characters entered at the terminal should now be echoed back.

## Recommended RS-422/485 Interface Devices

Some customers have made special interface boards that were not compatible with RS-422/485 standards. A listing of interface products that have been used successfully by a variety of AR-C users is provided below.

- ① RS-422/485 to RS-232C converter -B & B model 422CON. Phone number: 815-434-0846.
- ② IBM RS-422/485 interface board—Qua-Tech model DS-201/DS-202 (Phone number: 216-434-3154).

If communication problems arise, contact Compumotor's Application Engineering Department at 800-358-9070.

## LEDs

The **POWER** LED on the decoder box front panel will be on if 120VAC is applied to the unit. If this LED is not on, verify that power is properly connected and applied.

The **STATUS** LED illuminates only when the encoder head is at the absolute zero position. If the encoder travels to the end of its absolute range, thus coming to a false zero position, the encoder will send an error message via RS-232C. This LED does not indicate fault conditions.

## Reducing Electrical Noise

---

Try to eliminate sources of possible noise interference. Potential noise sources include inductive devices such as solenoids, relays, motors, and motor starters operated by a hard contact.

A technique for improving the AR-C's noise immunity is to connect the case of the motor (to which the encoder head is attached) to the **GND** input on the decoder box.

For more information on identifying and suppressing electrical noise, refer to the *Compumotor Programmable Motion Control Catalog*.

## Diagnostic Code Descriptions

---

Diagnostic Code	Description	Course of Action
$\emptyset$	No error present.	System is functioning properly.
1	Not ready for read. Reset must have occurred.	Check your AC power line and ensure that it is clean. If the power line is O.K., apply power and try reading the position again.
2	EEPROM failure. In this condition, the AR-C will automatically default to factory parameters. If parameters cannot be saved with the SS command, the EEPROM has failed.	Try saving the parameters using the SS command. Cycle power after you complete the save and the error should not re-appear. If the problem persists, you may have a EEPROM problem. Call the factory.
3	Data error. Positional read needs to be repeated. If this persists, noise or a bad component may be the cause. A rollover will also cause this error.	Check for noise in the encoder. (Refer to the noise reduction procedures explained in this chapter).
5	Fine resolution data error. Position read will need to be repeated. This usually occurs when the electronics are not tuned to the encoder head.	Try to read the position again. If you receive this error on a regular basis, call the factory.
8	Encoder Head Disconnected	Connect encoder head to encoder box.

\* All error codes are cleared after every read.

*Error Code Descriptions*

## Returning the System for Maintenance

---

If you must return your AR-C system to affect repairs or upgrades, use the following steps:

- ① Get the serial number and the model number of the defective unit, and a purchase order number to cover repair costs in the event the unit is determined by the manufacturers to be out of warranty.
- ② Before you return the unit, have someone from your organization with a technical understanding of the AR-C system and its application call Compumotor's Applications Engineering Department (800-358-9070). Your representative should be able to provide the following information.
  - What is the extent of the failure/reason for return?
  - How long did it operate?
  - Did any other items fail at the same time?
  - What was happening when the unit failed (i.e., installing the unit, cycling power, starting other equipment, etc)?
  - How was the product configured (in detail)?
  - What, if any, cables were modified and how?
  - With what equipment is the unit interfaced?
  - What was the application?
  - What was the system environment (temperature, enclosure, spacing, unit orientation, contaminants, etc.)?
  - What upgrades, if any, are required (hardware, software, user guide)?
- ③ In the USA, call Parker Compumotor for a Return Material Authorization (RMA) number. Returned products cannot be accepted without an RMA number. The phone number for Parker Compumotor's Customer Service Department is 800-722-2282.

Ship the unit to: Parker Hannifin Corporation  
Compumotor Division  
5500 Business Park Drive  
Rohnert Park, CA 94928  
Attn: RMA # xxxxxxxx

- ④ In the UK, call Parker Digiplan for a GRA (Goods Returned Authorization) number. Returned products cannot be accepted without a GRA number. The phone number for Parker Digiplan Repair Department is 0202-690911. The phone number for Parker Digiplan Service/Applications Department is 0202-699000.

Ship the unit to:  
Parker Digiplan Ltd.  
21, Balena Close  
Poole, Dorset  
England BH17 7DX

- ⑤ Elsewhere: Contact the distributor who supplied the equipment.

# I N D E X

- 16-BIT DATA OUTPUT 26
  - DATA REQUEST (DR) OUTPUT 26
  - DATA VALID (DV) OUTPUT 26
  - DEVICE ENABLE (DE) INPUT 26
- 16-BIT PARALLEL CONNECTIONS 14
- 8-BIT DATA OUTPUT 23
  - DATA REQUEST (DR) OUTPUT 23
  - DATA VALID (DV) OUTPUT 23
  - DEVICE ENABLE (DE) INPUT 23
- 8-BIT PARALLEL CONNECTIONS 13
  
- ABSOLUTE POSITION 43
- ABSOLUTE ZERO POSITION 51
- AR-C ENCODER HEAD DIMENSIONS 32
- ASCII CHARACTERS 12, 13
- AX-A INDEXER/DRIVE 15, 16
- BAUD RATE 18
- BUFFERED COMMANDS 41
- BYTE CONVERSION TABLE 22
  
- CABLE 12
- COMMAND
  - ATTRIBUTES 41
  - CHARACTERISTICS 40
  - DEFAULT 40
  - DESCRIPTION 41
  - EXAMPLE 41
  - IDENTIFIER 39
  - NAME 39
  - RANGE 40
  - SYNTAX 40
  - TYPE 40
  - UNITS 40
  - VERSION 40
- CTS 50
  
- DAISY CHAIN 18
- DATA BITS 18
- DECODER
  - MOUNTING
    - DIMENSIONS 31
    - MOUNTING OPTIONS 10
- DECODER BOX 3, 11
  - DIP SWITCHES 3, 4
  - MOTION CONTROLLER CONFIGURATION 4
  - STANDALONE MODE 4
- DECODER BOX DIMENSIONS 31
- DELIMITER IV
- DEVICE ADDRESS 46
- DIAGNOSTIC CODE DESCRIPTIONS 52
- DIP SWITCH SETTINGS 34
  - OPERATIONAL MODE 34
- DSR 50
- DTR 50
- DUMB TERMINAL 18
  
- ECHOES 6
- ELECTRICAL NOISE 51
- ELECTRICAL SPECIFICATIONS 33
- ENCODER
  - MOUNTING
    - FLANGE MOUNTING 10
    - STANDARD SERVO MOUNT 10
- ENVIRONMENTAL CONDITIONS 9
  
- ENVIRONMENTAL SPECIFICATIONS 33
- ERROR CHECKING 44
- GOODS RETURNED AUTHORIZATION 53
- GROUNDING 9, 11
  - SINGLE-POINT 11
- GROUNDING ELECTRODE 11
  
- HANDSHAKING 6
- HEXADECIMAL 47
  
- I/O CIRCUIT DESCRIPTIONS 33
- IMMEDIATE COMMANDS 41
- INDEXER MODE 15
- INDEXER MODE CONNECTIONS 15
- INPUTS 22
- INTERFACE MODES 17
  - SERIAL MODE 17
- INTERPRETING 16-BIT BINARY OUTPUT 27
- INTERPRETING 8-BIT BCD OUTPUT 24
- INTERPRETING 8-BIT BINARY OUTPUT 25
  
- JSI SERVO CONTROLLER 15
- JUMPER FUNCTIONS 36
- JUMPER LOCATIONS 37
- JUMPER SETTINGS 36
- JUMPERS 36
  - CIRCUIT DIAGRAM 36
  
- LAYOUT 9
  
- MECHANICAL SPECIFICATIONS 33
- MODEL 4000 CONTROLLER 15
- MODEL 500 INDEXER 15
  - ABS/INC ENCODER 15
- MOUNTING 9, 10
  - DECODER BOX 10
  - ENCODER 10
  - FAN COOLING 10
  - NEMA-APPROVED ENCLOSURE 10
  - PANEL LAYOUT GUIDELINES 10
- MULTI-DROP 20
- MULTI-DROP WIRING 20
- MULTIPLEX CONFIGURATION 28
- MULTIPLEXING 28
  - CONFIGURATION 28
  - RESISTOR PACKS 28
  
- NONVOLATILE MEMORY 19, 21
  
- OFFSET PUSHBUTTON 29
  - CLEAR THE POSITION OFFSET 29
  - JUMPER JU6 29
  - STATUS LED 29
  - ZERO INPUT 29
- OUTPUT FORMAT 22
- OUTPUTS 22
  
- PARALLEL OUTPUT CONTROL 21
  - INTERPRETING PARALLEL DATA 22
- PARITY 18
- POWER 5
- POWER CONNECTIONS 12
  
- RETURN MATERIAL AUTHORIZATION 52
  
- RS-232C DAISY CHAIN 18
- RS-232C INTERFACE 6
  - POWER LED 6
  - SERIAL CONNECTIONS 6
- RS-232C SERIAL CONNECTIONS 12
- RS-422/485
  - JUMPER SETTINGS 36
- RS-422/485 FULL-DUPLEX SERIAL CONNECTION 13
- RS-422/485 INTERFACE 7, 20
  - MULTI-DROPPING 20
  - POWER LED 7
  - SERIAL CONNECTION 7
- RTS 50
  
- SERIAL OUTPUT CONTROL 17
  - HOST COMPUTER 17
- SHIELDED CABLES 12
- SHIELDING 9
- SHIP KIT 3
- SOFTWARE COMMANDS
  - AR 42
  - DS 42
  - PB 42
  - PR 43
  - RP 43
  - RV 44
  - SE 44
  - SF 45
  - SI 45
  - SL 45
  - SN 46
  - SO 46
  - SP 47
  - SS 47
  - Z 47
- SOFTWARE REVISION 44
- STANDALONE MODE 6
  - BENCH TEST 6
  - RS-232C INTERFACE 6
  - RS-422/485 INTERFACE 7
- START/STOP BIT(S) 18
- SX INDEXER/DRIVE 15
- SX/SXF INDEXER/DRIVE 16
- SYSTEM CONNECTIONS 10
  
- TERMINAL EMULATION 6
  - PRO-COMM™ 6
  - XWARE™ 6
- TIMING—16-BIT PARALLEL OUTPUT 26
- TIMING—8-BIT PARALLEL OUTPUT 23
  
- WIRING 9

