

Parker I/O-System PIO-346

DeviceNet ECO + I/O-Modules



Manual

Technical Description,
Installation and Configuration

Copyright © 2003 Parker Hannifin GmbH EME
All rights reserved.

Microsoft Word, Microsoft Office, Windows®, Window 95™, Window 98™, Windows NT®, Window 2000™, Window XP™ and MS-DOS™ are trademarks of Microsoft Corporation.

EME - Electromechanical Automation Europe

Germany: Parker Hannifin GmbH
Electromechanical Automation
Postfach: 77607-1720
Robert-Bosch-Str. 22
D-77656 Offenburg
Tel.: +49 (0)781 509-0
Fax: +49 (0)781 509-176

E-mail: sales.hauser@parker.com
Internet: www.parker-eme.com

England: Parker Hannifin plc
Electromechanical Automation
21 Balena Close
Poole, Dorset England, BH17 /DX UK
Tel.: +44 (0)1202 69 9000
Fax: +44 (0)1202 69 5750

E-mail: sales.digiplan@parker.com
Internet: www.parker-eme.com

Italy: Parker Hannifin S. p. A
Electromechanical Automation
Via Gounod 1
I-20092 Cinisello Balsamo (MI), Italy
Tel.: +39 (0)2660 12459
Fax: +39 (0)2660 12808

E-mail: sales.sbc@parker.com
Internet: www.parker-eme.com

EMN - Electromechanical Automation North America

USA: Parker Hannifin Corporation
Electromechanical Automation
5500 Business Park Drive
Rohnert Park, CA 94928
Phone #: (800) 358-9068
FAX #: (707) 584-3715

E-mail: CMR_help@parker.com
Internet: www.compumotor.com

TABLE OF CONTENTS

1	Important comments	5
1.1	Legal principles.....	5
1.2	Symbols.....	6
1.3	Font Conventions	6
1.4	Number Notation	6
1.5	Safety Notes.....	7
1.6	Scope	7
1.7	Abbreviation.....	8
2	I/O-SYSTEM	9
2.1	I/O-System Description	9
2.2	Technical Data.....	10
2.3	Manufacturing Number.....	14
2.4	Storage, Assembly and Transport.....	14
2.5	Mechanical Setup	14
2.6	Power Supply	21
2.7	Grounding.....	25
2.8	Shielding (Screening).....	28
2.9	Assembly Guidelines / Standards	28
3	Fieldbus Coupler.....	29
3.1	Fieldbus Coupler	29
4	I/O modules.....	47
4.1	PIO-400 [2 DI DC 24 V 3.0 ms, high-side switching]	47
4.2	PIO-402 [4 DI DC 24 V 3.0 ms, high-side switching]	50
4.3	PIO-430 [8 DI DC 24 V 3.0 ms, high-side switching]	53
4.4	PIO-468 [4 AI DC 0-10 V, Single-Ended]	56
4.5	PIO-480 [2 AI 0-20 mA Differential Measurement Input].....	60
4.6	PIO-501 [2 DO DC 24 V 0.5 A, high-side switching]	64
4.7	PIO-504 [4 DO DC 24 V 0.5 A, high-side switching]	67
4.8	PIO-530 [8 DO DC 24 V 0.5 A, high-side switching]	70
4.9	PIO-550 [2 AO DC 0-10 V].....	73
4.10	PIO-552 [2 AO 0-20 mA]	77
4.11	PIO-600 [End Module].....	81
4.12	PIO-602 [24 V DC Power Supply]	83
5	DeviceNet.....	86
5.1	Description.....	86
5.2	Network Architecture	87
5.3	Network Communication	90
5.4	Module Characteristics.....	91
5.5	Process Data and Diagnostic Status.....	91
5.6	Configuration / Parametering with the Object Model.....	94
6	Use in Hazardous Environments.....	111
6.1	Foreword	111
6.2	Protective measures.....	111
6.3	Classification meeting CENELEC and IEC	111
6.4	Classifications meeting the NEC 500	115
6.5	Identification	117
6.6	Installation regulations.....	119
7	Glossary.....	120
8	Literature list	121
9	Index.....	122

1 Important comments

To ensure fast installation and start-up of the units described in this manual, we strongly recommend that the following information and explanation is carefully read and adhered to.

1.1 Legal principles

1.1.1 Copyright

This manual is copyrighted, together with all figures and illustrations contained therein. Any use of this manual which infringes the copyright provisions stipulated herein, is not permitted. Reproduction, translation and electronic and photo-technical archiving and amendments require the written consent. Non-observance will entail the right of claims for damages.

1.1.2 Personnel qualification

The use of the product detailed in this manual is exclusively geared to specialists having qualifications in PLC programming, electrical specialists or persons instructed by electrical specialists who are also familiar with the valid standards. The manufacturer declines all liability resulting from improper action and damage to products and third party products due to non-observance of the information contained in this manual.

1.1.3 Intended use

For each individual application, the components supplied are to work with a dedicated hardware and software configuration. Modifications are only admitted within the framework of the possibilities documented in the manuals. All other changes to the hardware and/or software and the non-conforming use of the components entail the exclusion of liability.

1.2 Symbols



Danger

Always abide by this information to protect persons from injury.



Warning

Always abide by this information to prevent damage to the device.



Attention

Marginal conditions must always be observed to ensure smooth operation.



ESD (Electrostatic Discharge)

Warning of damage to the components by electrostatic discharge. Observe the precautionary measure for handling components at risk.



Note

Routines or advice for efficient use of the device and software optimization.



More information

References on additional literature, manuals, data sheets and INTERNET pages

1.3 Font Conventions

<i>Italic</i>	Names of path and files are marked italic i.e.: <i>C:\programs</i>
<i>Italic</i>	Menu items are marked as bold italic i.e.: <i>Save</i>
\	A backslash between two names marks a sequence of menu items i.e.: <i>FileNew</i>
END	Press buttons are marked as bold with small capitals i.e.: ENTER
< >	Keys are marked bold within angle brackets i.e.: <F5>
Courier	Program code is printed with the font Courier. i.e.: END_VAR

1.4 Number Notation

Number Code	Example	Note
Decimal	100	normal notation
Hexadecimal	0x64	C notation
Binary	'100' '0110.0100'	Within ', Nibble separated with dots

1.5 Safety Notes

**Attention**

Switch off the I/O-system prior to working on bus modules!

In the event of deformed contacts, the module in question is to be replaced, as its functionality can no longer be ensured on a long-term basis.

The components are not resistant against materials having seeping and insulating properties. Belonging to this group of materials is: e.g. aerosols, silicones, triglycerides (found in some hand creams).

If it cannot be ruled out that these materials appear in the component environment, then additional measures are to be taken:

- installation of the components into an appropriate enclosure
- handling of the components only with clean tools and materials.

**Attention**

Cleaning of soiled contacts may only be done with ethyl alcohol and leather cloths. Thereby, the ESD information is to be regarded.

Do not use any contact spray. The spray may impair the functioning of the contact area.

The I/O-SYSTEM and its components are an open system. It must only be assembled in housings, cabinets or in electrical operation rooms. Access must only be given via a key or tool to authorized qualified personnel.

The relevant valid and applicable standards and guidelines concerning the installation of switch boxes are to be observed.

**ESD (Electrostatic Discharge)**

The modules are equipped with electronic components that may be destroyed by electrostatic discharge. When handling the modules, ensure that the environment (persons, workplace and packing) is well grounded. Avoid touching conductive components, e.g. gold contacts.

1.6 Scope

This manual describes the modular I/O-SYSTEM with the DeviceNet ECO fieldbus coupler.

Description

DeviceNet ECO Fieldbus coupler, 125 kBaud ... 500 kBaud;
digital and analog signals

1.7 Abbreviation

AI	Analog Input
AO	Analog Output
CAL	CAN Application Layer
CAN	Controller Area Network
DI	Digital Input
DIP	Dual In-line Package
DO	Digital Output
EDS	Electronic Data Sheets
I/O	Input/Output
ID	Identifier, Identification
Idx	Index
ISO/ OSI	International Organization for Standardization / Open Systems Interconnection (model)
HB	High Byte
HW	Hardware
LB	Low Byte
MAC ID	Media Access Control Identifier (nodeaddress)
MS	Module Status
NMT	Network Management
NS	Network Status
RO	Read Only
RW	Read/Write
SW	Software

2 I/O-SYSTEM

2.1 I/O-System Description

The I/O-SYSTEM is a modular, fieldbus independent I/O system. The structure described here consists of an ECO fieldbus coupler (1) and up to 64 connected fieldbus modules (2) for any kind of signal. Together, these make up the fieldbus node. The end module (3) completes the node.

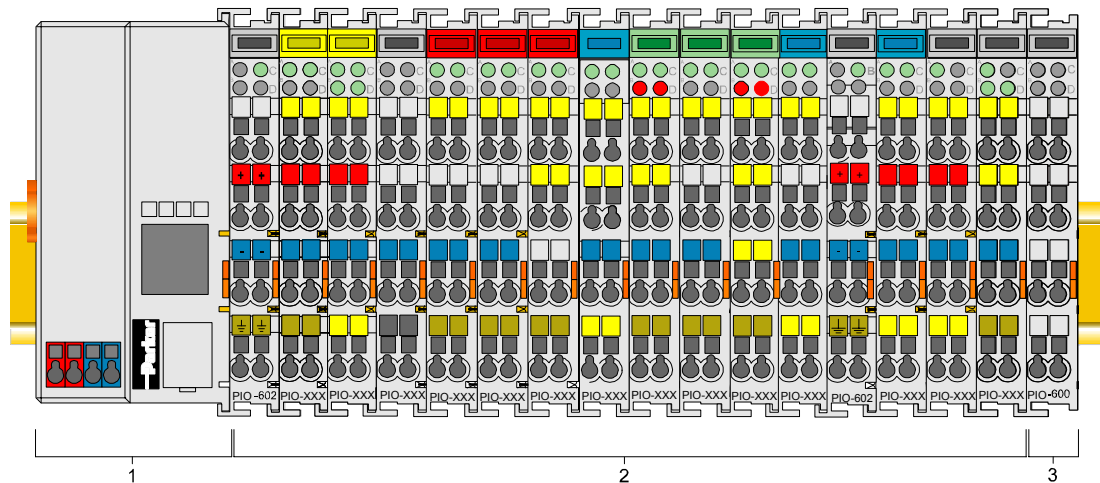

Fig. 2-1: Fieldbus node

ECO couplers for fieldbus systems such as PROFIBUS, CANopen and DeviceNet are available.

The ECO coupler contains the fieldbus interface, electronics and a power supply terminal. The fieldbus interface forms the physical interface to the relevant fieldbus. The electronics process the data of the bus modules and make it available for the fieldbus communication. The 24 V I/O-system supply are fed in via the integrated power supply terminal.

The fieldbus coupler communicates via the relevant fieldbus.

At first the ECO coupler is conceived for applications with digital I/O functions. Bus modules for diverse digital and analog I/O functions and special functions can be connected as well. The communication between the ECO coupler and the bus modules is carried out via an internal bus.

The I/O-SYSTEM has a clear port level with LEDs the status indication, insertable mini WSB markers and pullout group marker carriers. The 3-wire technology supplemented by a ground wire connection allows for direct sensor/actuator wiring.

2.2 Technical Data

Mechanic	
Material	Polycarbonate, Polyamide 6.6
Dimensions Coupler	50 mm x 65* mm x 97 mm
Dimensions I/O module, single	12 mm x 64* mm x 100 mm
Dimensions I/O module, double	24 mm x 64* mm x 100 mm
Installation	on DIN 35 with interlock
modular by	double featherkey-dovetail
Mounting position	any position
Length of entire node	≤ 831 mm
Marking	marking label type 247 and 248 paper marking label 8 x 47 mm
Wire range	
Wire range	CAGE CLAMP® Connection 0,08 mm ² ... 2,5 mm ² AWG 28-14 8 – 9 mm Stripped length
Contacts	
Power jumpers contacts	blade/spring contact self-cleaning
Current via power contacts _{max}	10 A
Voltage drop at I _{max}	< 1 V/64 modules
Data contacts	slide contact, hard gold plated 1,5μ, self-cleaning
Climatic environmental conditions	
Operating temperature	0 °C ... 55 °C
Storage temperature	-20 °C ... +85 °C
Relative humidity	95 % without condensation
Resistance to harmful substances	acc. to IEC 60068-2-42 and IEC 60068-2-43
Special conditions	Ensure that additional measures for components are taken, which are used in an environment involving: – dust, caustic vapors or gasses – ionization radiation.
Mechanical strength	
Vibration resistance	acc. to IEC 60068-2-6
Shock resistance	acc. to IEC 60068-2-27
Free fall	acc. to IEC 60068-2-32 ≤ 1m (module in original packing)

* from upper edge of DIN 35 rail

Safe electrical isolation			
Air and creepage distance	acc. to IEC 60664-1		
Degree of protection			
Degree of protection	IP 20		
Electromagnetic compatibility*			
Directive	Test values	Strength class	Evaluation criteria
Immunity to interference acc. to EN 50082-2 (96)			
EN 61000-4-2	4kV/8kV	(2/4)	B
EN 61000-4-3	10V/m 80% AM	(3)	A
EN 61000-4-4	2kV	(3/4)	B
EN 61000-4-6	10V/m 80% AM	(3)	A
Emission of interference acc. to EN 50081-2 (94)		Measuring distance	Class
EN 55011	30 dB μ V/m	(30m)	A
	37 dB μ V/m		
Emission of interference acc. to EN 50081-1 (93)		Measuring distance	Class
EN 55022	30 dB μ V/m	(10m)	B
	37 dB μ V/m		
Range of application	Required specification emission of interference	Required specification immunity to interference	
Industrial areas	EN 50081-2 : 1993	EN 50082-2 : 1996	
Residential areas	EN 50081-1 : 1993 ^{*)}	EN 50082-1 : 1992	

*) The I/O-system meets the requirements on emission of interference in residential areas with the fieldbus coupler for:

CANopen 337

DeviceNet 306

With a special permit, the I/O-system can also be implemented with other fieldbus couplers in residential areas (housing, commercial and business areas, small-scale enterprises). The special permit can be obtained from an authority or inspection office. In Germany, the Federal Office for Post and Telecommunications and its branch offices issues the permit.

It is possible to use other field bus couplers under certain boundary conditions. Please contact the manufacturer.

Maximum power dissipation of the components	
Bus modules	0,8 W / bus terminal (total power dissipation, system/field)
ECO Fieldbus coupler	2,0 W / coupler

**Warning**

The power dissipation of all installed components must not exceed the maximum conductible power of the housing (cabinet).

When dimensioning the housing, care is to be taken that even under high external temperatures, the temperature inside the housing does not exceed the permissible ambient temperature of 55 °C.

Dimensions

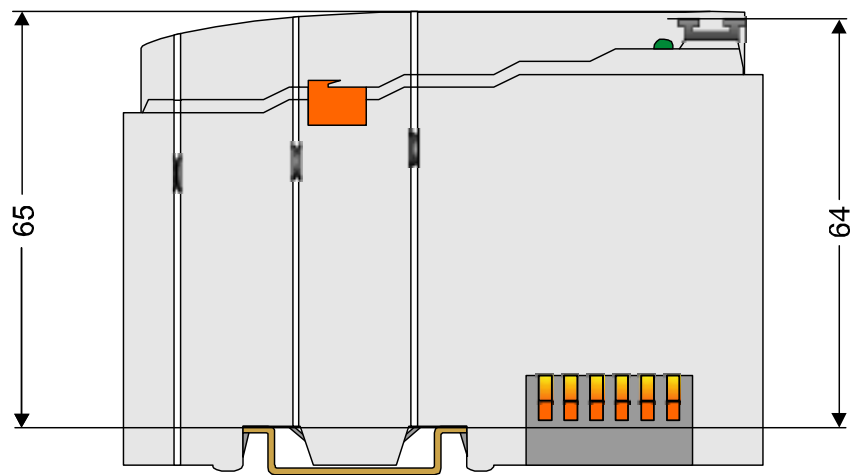
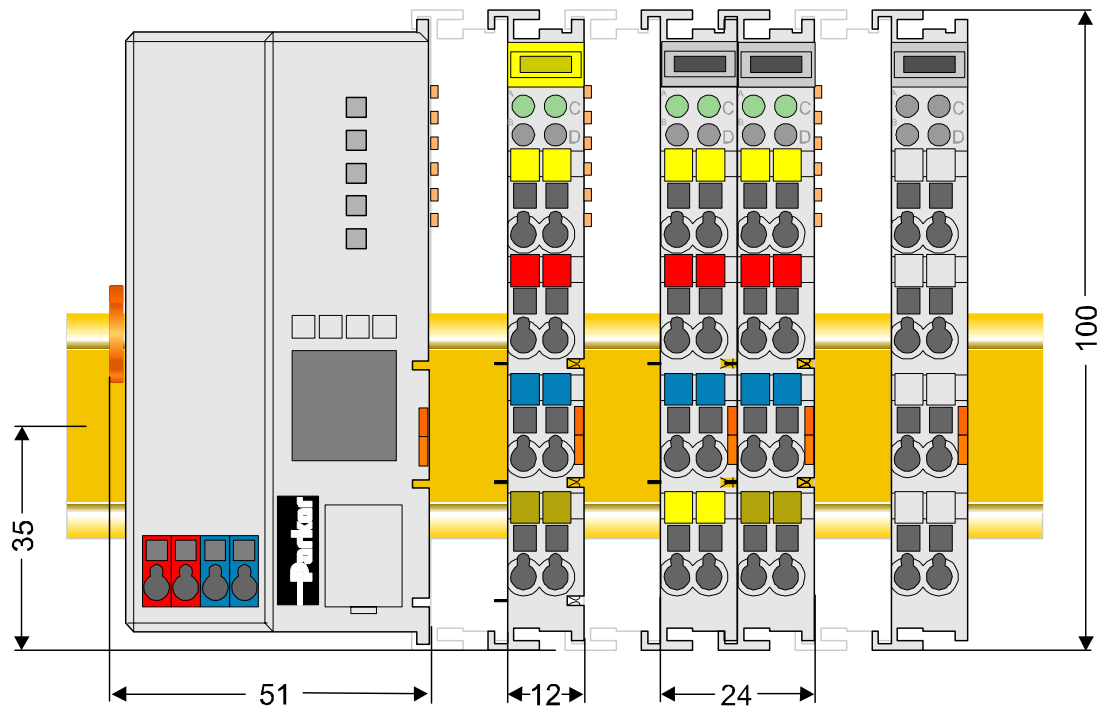

Side view

Dimensions in mm

Fig. 2-2: Dimensions

2.3 Manufacturing Number

The manufacturing number is part of the lateral marking on the component.

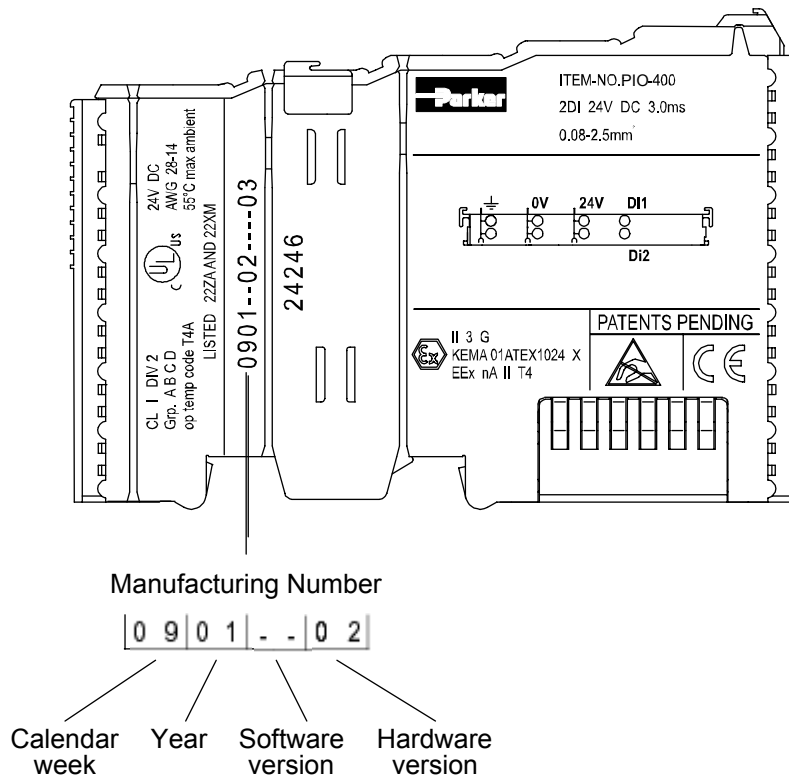

Fig. 2-3: Manufacturing Number

The manufacturing number consists of the production week and year, the software version (if available), the hardware version of the component, the firmware loader (if available) and further internal information for the manufacturer.

The production number is also printed on the cover of the configuration and programming interface of the fieldbus coupler.

2.4 Storage, Assembly and Transport

Wherever possible, the components are to be stored in their original packaging. Likewise, the original packaging provides optimal protection during transport.

When assembling or repacking the components, the contacts must not be soiled or damaged. The components must be stored and transported in appropriate containers/packaging. Thereby, the ESD information is to be regarded.

Statically shielded transport bags with metal coatings are to be used for the transport of open components for which soiling with amine, amide and silicone has been ruled out, e.g. 3M 1900E.

2.5 Mechanical Setup

2.5.1 Installation Position

Along with horizontal and vertical installation, all other installation positions are allowed.

**Attention**

In the case of vertical assembly, an end stop has to be mounted as an additional safeguard against slipping.

2.5.2 Total Expansion

The maximum total expansion of a node is calculated as follows:

Quantity	Width	Components
1	50 mm	ECO coupler
64	12 mm	bus modules - inputs / outputs - power supply modules - etc.
1	12 mm	end module
sum	830 mm	

**Warning**

The maximal total expansion of a node must not exceed 830 mm.

2.5.3 Assembly onto Carrier Rail

Carrier Rail Properties

All I/O-system components can be snapped directly onto a carrier rail in accordance with the European standard EN 50022 (DIN 35).

Carrier rails have different mechanical and electrical properties. For the optimal I/O-system setup on a carrier rail, certain guidelines must be observed:

- The material must be non-corrosive.
- Most components have a contact to the carrier rail to ground electro-magnetic disturbances. In order to avoid corrosion, this tin-plated carrier rail contact must not form a galvanic cell with the material of the carrier rail which generates a differential voltage above 0.5 V (saline solution of 0.3% at 20°C) .
- The carrier rail must optimally support the EMC measures integrated into the I/O-system and the shielding of the bus module connections.
- A sufficiently stable carrier rail should be selected and, if necessary, several mounting points (every 20 cm) should be used in order to prevent bending and twisting (torsion).
- The geometry of the carrier rail must not be altered in order to secure the safe hold of the components. In particular, when shortening or mounting the carrier rail, it must not be crushed or bent.
- The base of the I/O components extends into the profile of the carrier rail. For carrier rails with a height of 7.5 mm, mounting points are to be riveted under the node in the carrier rail (slotted head captive screws or blind rivets).

2.5.4 Spacing

The spacing between adjacent components, cable conduits, casing and frame sides must be maintained for the complete field bus node.

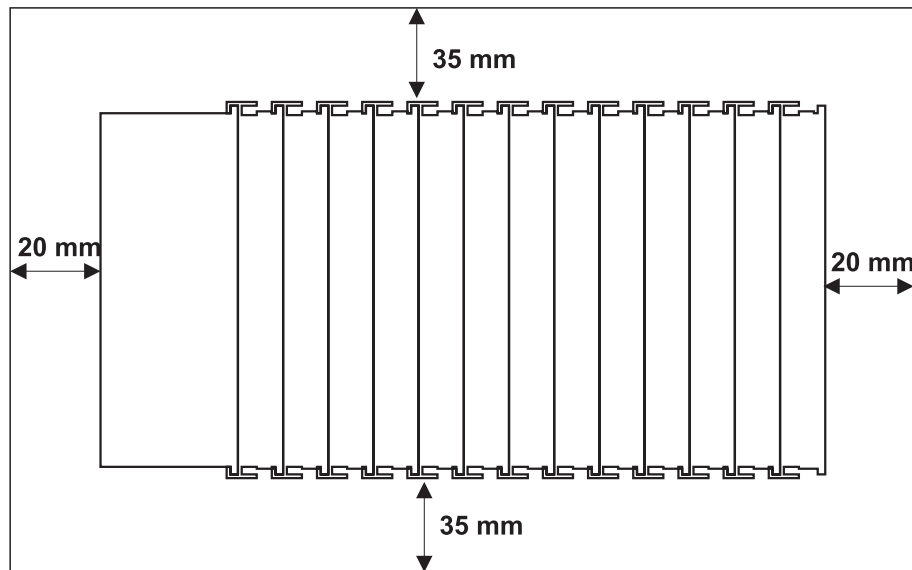

Fig. 2-4: Spacing

The spacing creates room for heat transfer, installation or wiring. The spacing to cable conduits also prevents conducted electromagnetic interferences from influencing the operation.

2.5.5 Plugging and Removal of the Components



Warning

Before work is done on the components, the voltage supply must be turned off.

In order to safeguard the ECO coupler from jamming, it should be fixed onto the carrier rail with the locking disc. To do so, push on the upper groove of the locking disc using a screwdriver.

To pull out the fieldbus coupler, release the locking disc by pressing on the bottom groove with a screwdriver and then pulling the orange colored unlocking lug.

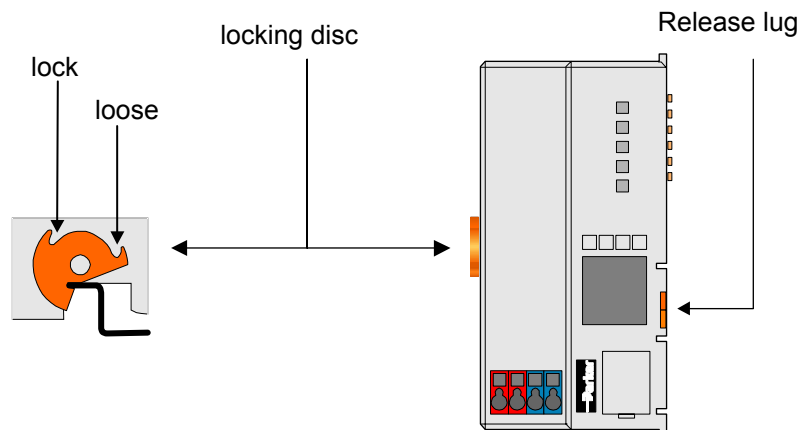

Fig. 2-5: Coupler and unlocking lug

It is also possible to release an individual I/O module from the unit by pulling an unlocking lug.

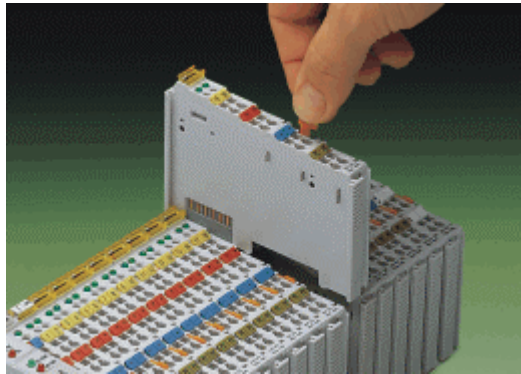

Fig. 2-6: removing bus terminal



Danger

Ensure that an interruption of the PE will not result in a condition which could endanger a person or equipment!

For planning the ring feeding of the ground wire, please see chapter "Protective Earth".

2.5.6 Assembly Sequence

All I/O-system components can be snapped directly on a carrier rail in accordance with the European standard EN 50022 (DIN 35).

The reliable positioning and connection is made using a tongue and groove I/O-system. Due to the automatic locking, the individual components are securely seated on the rail after installing.

Starting with the ECO coupler, the bus modules are assembled adjacent to each other according to the project planning. Errors in the planning of the node in terms of the potential groups (connection via the power contacts) are recognized, as the bus modules with power contacts (male contacts) cannot be linked to bus modules with fewer power contacts.

**Attention**

Always link the bus modules with the ECO coupler, and always plug from above.

**Warning**

Never plug bus modules from the direction of the end terminal. A ground wire power contact, which is inserted into a terminal without contacts, e.g. a 4-channel digital input module, has a decreased air and creepage distance to the neighboring contact. Always terminate the fieldbus node with an end module (PIO-600).

2.5.7 Internal Bus / Data Contacts

Communication between the ECO coupler and the bus modules as well as the I/O-system supply of the bus modules is carried out via the internal bus. It is comprised of 6 data contacts, which are available as self-cleaning gold spring contacts.

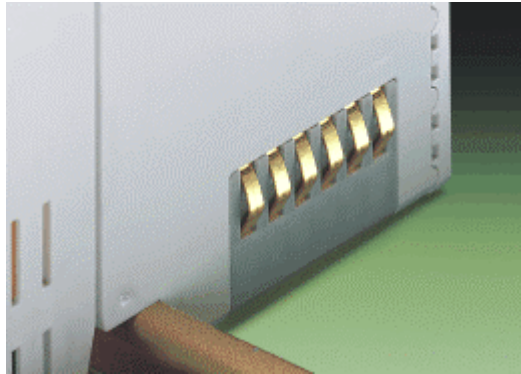

Fig. 2-7: Data contacts



Warning

Do not touch the gold spring contacts on the I/O Modules in order to avoid soiling or scratching!



ESD (Electrostatic Discharge)

The modules are equipped with electronic components that may be destroyed by electrostatic discharge. When handling the modules, ensure that the environment (persons, workplace and packing) is well grounded. Avoid touching conductive components, e.g. gold contacts.

2.5.8 Power Contacts

Self-cleaning power contacts, are situated on the side of the components which further conduct the supply voltage for the field side. These contacts come as touchproof spring contacts on the right side of the coupler and the bus module. As fitting counterparts the module has male contacts on the left side.



Danger

The power contacts are sharp-edged. Handle the module carefully to prevent injury.



Attention

Please take into consideration that some bus modules have no or only a few power jumper contacts. The design of some modules does not allow them to be physically assembled in rows, as the grooves for the male contacts are closed at the top.

Power jumper contacts

Blade	0	0	3	2
Spring		0	3	3
				2

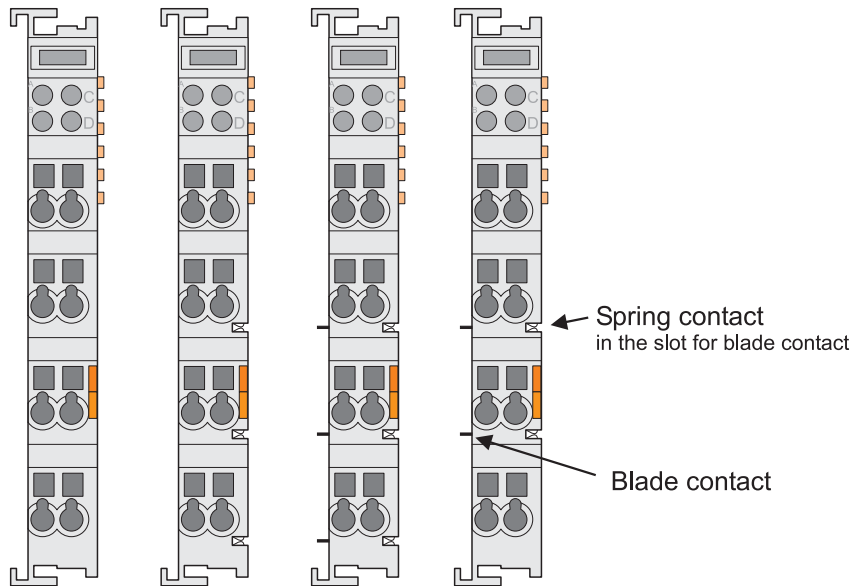

Fig. 2-8: Example for the arrangement of power contacts

2.5.9 Wire Connection

All components have CAGE CLAMP® connections.

The CAGE CLAMP® connection is appropriate for solid, stranded and fine-stranded conductors. Each clamping unit accommodates one conductor.

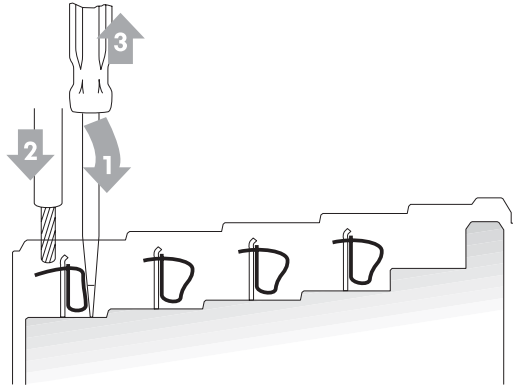

Fig. 2-9: CAGE CLAMP® Connection

The operating tool is inserted into the opening above the connection. This opens the CAGE CLAMP®. Subsequently the conductor can be inserted into the opening. After removing the operating tool, the conductor is safely clamped.

More than one conductor per connection is not permissible. If several conductors have to be made at one connection point, then they should be made away from the connection point using Terminal Blocks. The terminal blocks may be jumpered together and a single wire brought back to the I/O module connection point.



Attention

If it is unavoidable to jointly connect 2 conductors, then a ferrule must be used to join the wires together.

Ferrule:

Length	8 mm
Nominal cross section _{max.}	1 mm ² for 2 conductors with 0.5 mm ² each.

2.6 Power Supply

2.6.1 Isolation

Within the fieldbus node, there are three electrically isolated potentials.

- Operational voltage for the fieldbus interface.
- Electronics of the couplers and the bus modules (internal bus).
- All bus modules have an electrical isolation between the electronics (internal bus, logic) and the field electronics. Some analog input modules have each channel electrically isolated, please see catalog.

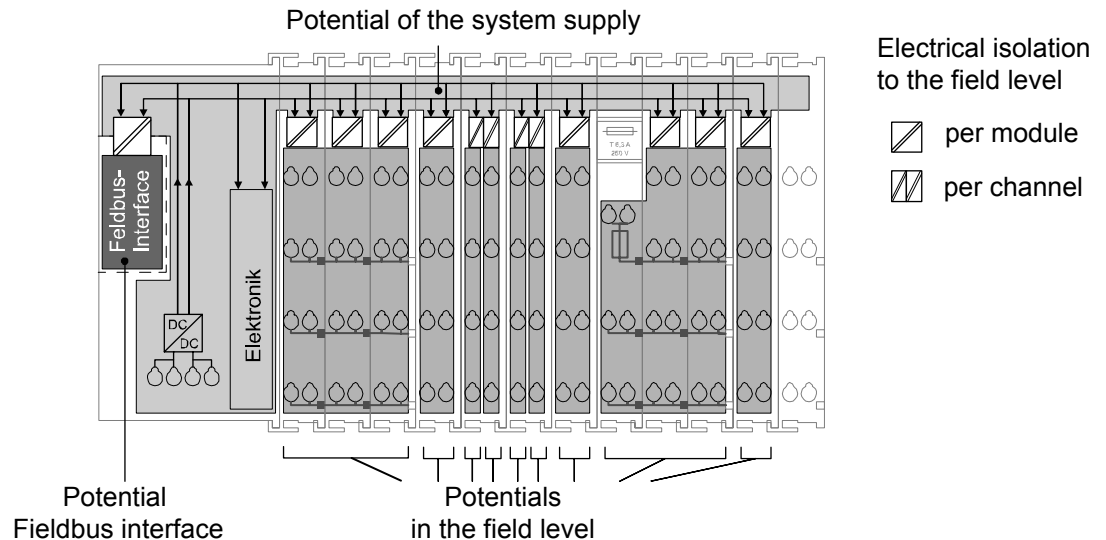

Fig. 2-10: Isolation



Attention

The ground wire connection must be present in each group. In order that all protective conductor functions are maintained under all circumstances, it is recommended that a ground wire be connected at the beginning and end of a potential group. (ring format, please see chapter "Grounding Protecti"). Thus, if a bus module comes loose from the node during servicing, then the protective conductor connection is still guaranteed for all connected field devices. When using a joint power supply unit for the 24 V I/O-system supply and the 24 V field supply, the electrical isolation between the internal bus and the field level is eliminated for the potential group.

2.6.2 I/O-system Supply

Connection

The I/O-SYSTEM requires a 24 V direct current I/O-system supply (-15% or +20 %). The power supply is provided via the coupler. The voltage supply is reverse voltage protected.

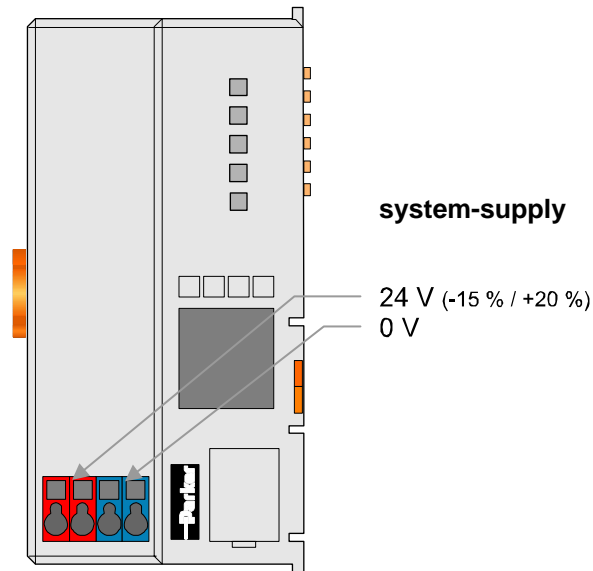

Fig. 2-11: I/O-system Supply

The direct current supplies all internal I/O-system components, e.g. ECO coupler electronics, fieldbus interface and bus modules via the internal bus (5 V I/O-system voltage). The 5 V I/O-system voltage is electrically connected to the 24 V I/O-system supply.

Alignment

Recommendation

A stable network supply cannot be taken for granted always and everywhere. Therefore, regulated power supply units should be used in order to guarantee the quality of the supply voltage.

The supply capacity of the ECO coupler can be taken from the technical data of the components.

Internal current consumption ^{*)}	Current consumption via I/O-system voltage: 5 V for electronics of the bus modules and ECO coupler
Residual current for bus terminals ^{*)}	Available current for the bus modules. Provided by the bus power supply unit. See ECO coupler

Example**ECO coupler:**

internal current consumption: 350 mA at 5V

residual current for bus modules : 650 mA at 5V

sum $I_{(5V) total}$: 1000 mA at 5V

The internal current consumption is indicated in the technical data for each bus terminal. In order to determine the overall requirement, add together the values of all bus modules in the node.

Example:

A node with a DeviceNet ECO Coupler consists of 16 digital output modules (PIO-530) and 14 digital input modules (PIO-430).

Current consumption:

16*25 mA = 400 mA

14*17 mA = 238 mA

Sum : 638 mA

The coupler can provide 638 mA (max. 650 mA) for the bus modules.

The maximum input current of the 24 V I/O-system supply is 260 mA. The exact electrical consumption ($I_{(24 V)}$) can be determined with the following formulas:

ECO Coupler

$I_{(5 V) total} =$ Sum of all the internal current consumption of the connected bus modules
+ internal current consumption of the ECO coupler

$I_{(5 V) total} =$ Sum of all the internal current consumptions of the connected bus modules

Input current $m I_{(24 V)} = 5 V / 24 V * I_{(5 V) total} / \eta$
 $\eta = 0.80$ (at nominal load)

**Note**

If the electrical consumption of the power supply point for the 24 V-I/O-system supply exceeds 260 mA for the ECO coupler, then the cause may be an improperly aligned node or a defect.

During the test, all outputs must be active.

2.6.3 Field Supply

Connection

Sensors and actuators can be directly connected to the relevant channel of the bus module in 1-/4 conductor connection technology. The bus module supplies power to the sensors and actuators. The input and output drivers of some bus modules require the field side supply voltage.

Power supply modules provides field side power. The connections are linked in pairs with a power contact.

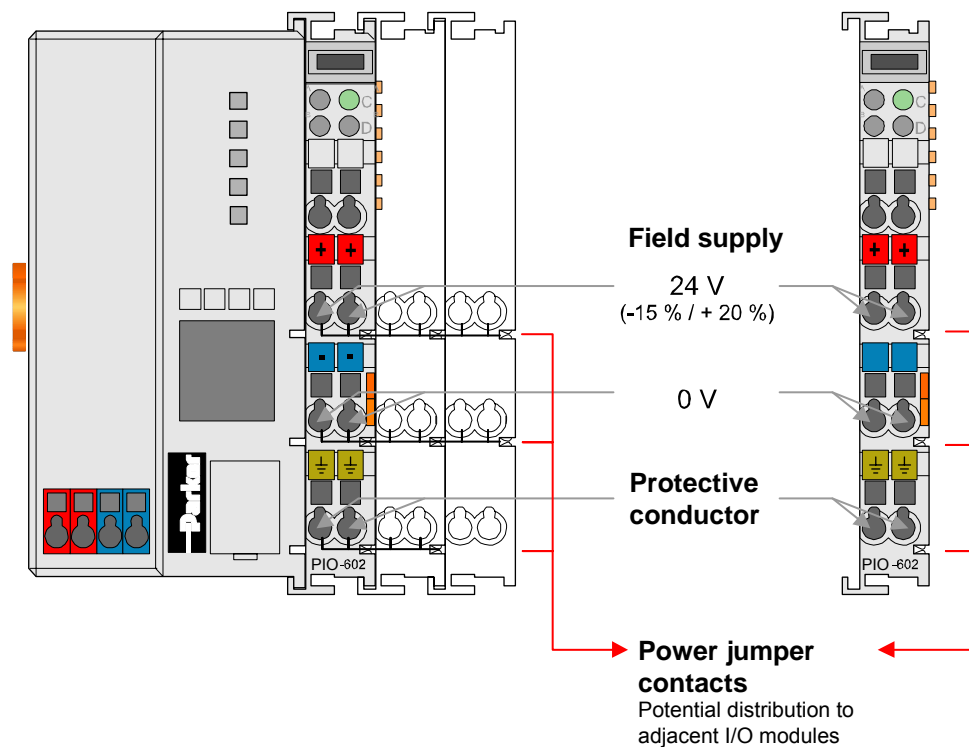

Fig. 2-12: Field Supply (Sensor / Actuator)

The supply voltage for the field side is automatically passed to the next module via the power jumper contacts when assembling the bus modules .

The current load of the power contacts must not exceed 10 A on a continual basis. The current load capacity between two connection terminals is identical to the load capacity of the connection wires.

By inserting an additional power supply module, the field supply via the power contacts is disrupted. From there a new power supply occurs which may also contain a new voltage potential.



Attention

Some bus modules have no or very few power contacts (depending on the I/O function). Due to this, the passing through of the relevant potential is disrupted. If a field supply is required for subsequent bus modules, then a power supply module must be used.

Note the data sheets of the bus modules.

2.6.4 Power Supply Unit

The I/O-SYSTEM requires a 24 V direct current I/O-system supply with a maximum deviation of -15% or +20 %.

Recommendation

A stable network supply cannot be taken for granted always and everywhere. Therefore, regulated power supply units should be used in order to guarantee the quality of the supply voltage.

A buffer (200 μ F per 1 A current load) should be provided for brief voltage dips. The I/O system buffers for approx. 1 ms.

The electrical requirement for the field supply is to be determined individually for each power supply point. Thereby all loads through the field devices and bus modules should be considered. The field supply as well influences the bus modules, as the inputs and outputs of some bus modules require the voltage of the field supply.



Note

The I/O-system supply and the field supply should be isolated in order to ensure bus operation in the event of short circuits on the actuator side.

2.7 Grounding

2.7.1 Grounding the DIN Rail

Framework Assembly

When setting up the framework, the carrier rail must be screwed together with the electrically conducting cabinet or housing frame. The framework or the housing must be grounded. The electronic connection is established via the screw. Thus, the carrier rail is grounded.



Attention

Care must be taken to ensure the flawless electrical connection between the carrier rail and the frame or housing in order to guarantee sufficient grounding.

Insulated Assembly

Insulated assembly has been achieved when there is constructively no direct conduction connection between the cabinet frame or machine parts and the carrier rail. Here the earth must be set up via an electrical conductor.

The connected grounding conductor should have a cross section of at least 4 mm².

Recommendation

The optimal insulated setup is a metallic assembly plate with grounding connection with an electrical conductive link with the carrier rail.

2.7.2 Grounding Function

The grounding function increases the resistance against disturbances from electro-magnetic interferences. Some components in the I/O system have a carrier rail contact that dissipates electro-magnetic disturbances to the carrier rail.

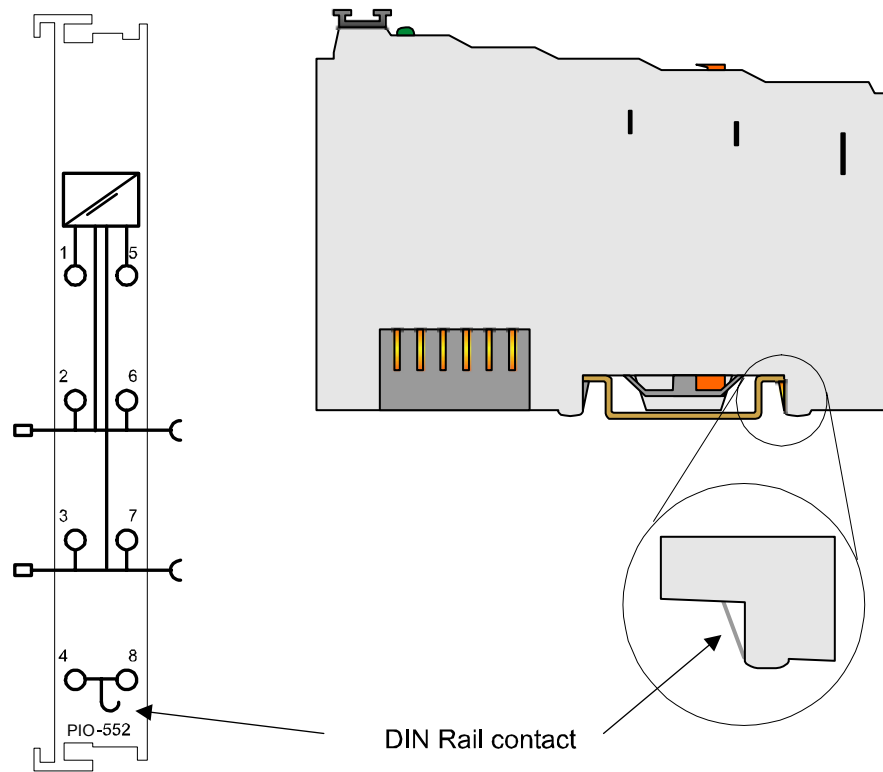

Fig. 2-13: Carrier rail contact



Attention

Care must be taken to ensure the direct electrical connection between the carrier rail contact and the carrier rail.

The carrier rail must be grounded.

For information on carrier rail properties, please see chapter "Carrier rail properties".

2.7.3 Grounding Protection

For the field side, the ground wire is connected to the lowest connection terminals of the power supply module. The ground connection is then connected to the next module via the Power Jumper Contact (PJC). If the bus module has the lower power jumper contact, then the ground wire connection of the field devices can be directly connected to the lower connection terminals of the bus module.



Attention

Should the ground conductor connection of the power jumper contacts within the node become disrupted, e.g. due to a 4-channel bus terminal, the ground connection will need to be re-established.

The ring feeding of the grounding potential will increase the I/O-system safety. When one bus module is removed from the group, the grounding connection will remain intact.

The ring feeding method has the grounding conductor connected to the beginning and end of each potential group.

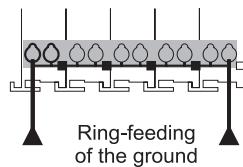

Fig. 2-14: Ring-feeding

2.8 Shielding (Screening)

2.8.1 General

The shielding of the data and signal conductors reduces electromagnetic interference thereby increasing the signal quality. Measurement errors, data transmission errors and even disturbances caused by overvoltage can be avoided.



Attention

Constant shielding is absolutely required in order to ensure the technical specifications in terms of the measurement accuracy.

The data and signal conductors should be separated from all high-voltage cables.

The cable shield should be potential. With this, incoming disturbances can be easily diverted.

The shielding should be placed over the entrance of the cabinet or housing in order to already repel disturbances at the entrance.

2.8.2 Bus Conductors

The shielding of the bus conductor is described in the relevant assembly guideline of the bus system.

2.8.3 Signal Conductors

Bus modules for most analog signals along with many of the interface bus modules include a connection for the shield.

2.9 Assembly Guidelines / Standards

DIN 60204,	Electrical equipping of machines
DIN EN 50178	Equipping of high-voltage systems with electronic components (replacement for VDE 0160)
EN 60439	Low voltage – switch box combinatio

3 Fieldbus Coupler

3.1 Fieldbus Coupler

This chapter includes:

3.1.1	Description	30
3.1.2	Hardware	31
3.1.3	Operating System	35
3.1.4	Process Image	35
3.1.5	Data Exchange	36
3.1.6	Configuration Software	40
3.1.7	Starting up DeviceNet Fieldbus Nodes.....	40
3.1.8	LED Display	42
3.1.9	Technical Data	46

3.1.1 Description

The ECO fieldbus coupler is designed for applications with a reduced scale I/O requirement. By using digital only process data, or small amounts of analog data, the ECO Fieldbus coupler retains all of the choices that are offered by the Series PIO I/O.

The coupler has an integrated supply terminal for the I/O-system voltage. The field power jumper contacts are supplied via a separate supply module.

The DeviceNet bus coupler is capable of supporting all I/O modules and automatically configures, creating a local process image.

DeviceNet allows the storing of the process image in the corresponding Master control (PLC, PC or NC).

The local process image is divided into two data zones containing the data received and the data to be sent.

The process data can be sent via the DeviceNet fieldbus to the PLC, PC or NC for further processing, and received from the field via DeviceNet TM.

The data of the analog modules is stored in the process image which is created automatically according to the order in which the modules are connected to the buscoupler. The bits of the digital modules are sent byte by byte and added to the analog data. If the amount of digital information exceeds 8 bits, the buscoupler automatically starts with a new byte.

3.1.2 Hardware

View

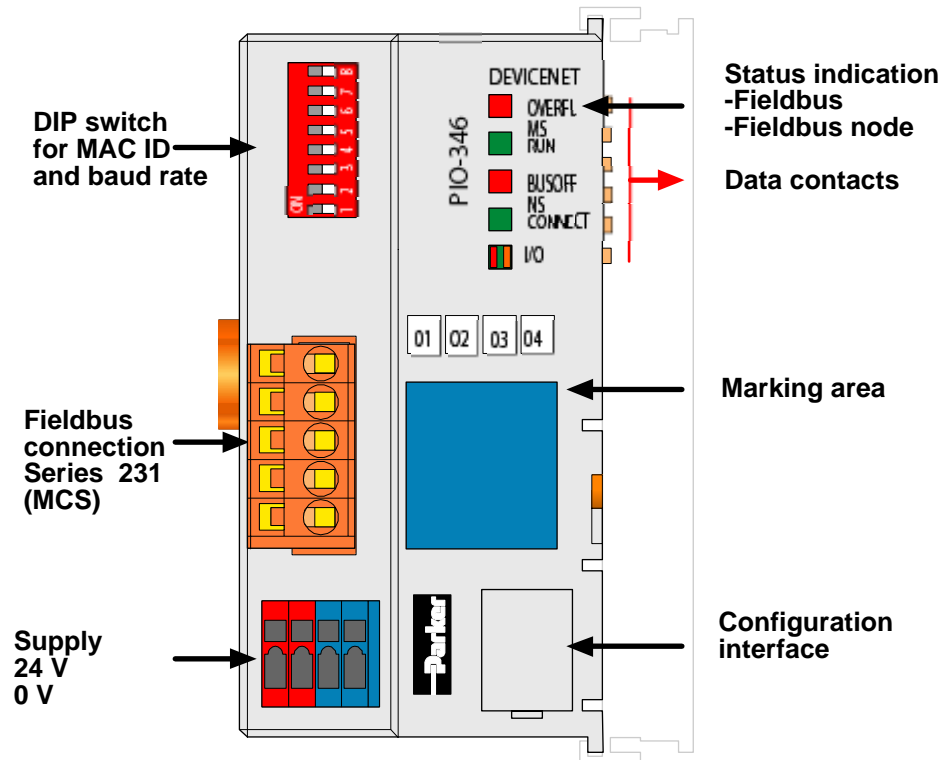

Fig. 3-1: ECO fieldbus coupler DeviceNet

The fieldbus coupler comprises of:

- Supply module with internal I/O-system supply module for the I/O-system supply
- Fieldbus interface with the bus connection
- Display elements (LED's) for status display of the operation, the bus communication, the operating voltages as well as for fault messages and diagnostics
- Configuration interface
- Electronics for communication with the I/O modules (internal bus) and the fieldbus interface

Device Supply

The supply is made via terminal blocks with CAGE CLAMP® connection. The device supply is intended for the I/O-system unit.

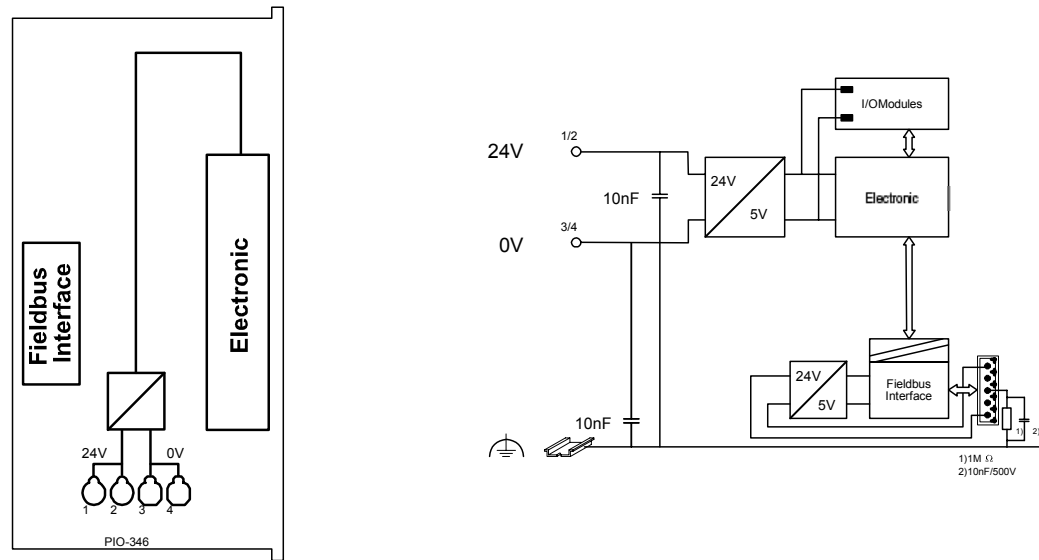

Fig. 3-2: Device supply

The integrated internal I/O-system supply module generates the necessary voltage to supply the electronics of the coupler and the connected I/O modules.

The fieldbus interface is supplied by the fieldbus.

Fieldbus Connection

For the field bus connection, the DeviceNet interface is equipped with a 5 pole header, its counter-piece being a plug connector (Open Style Connector).

The table below shows the connection diagram, the colors resulting in accordance with the DeviceNet specification and are identical to the conductor colors of the DeviceNet cables.

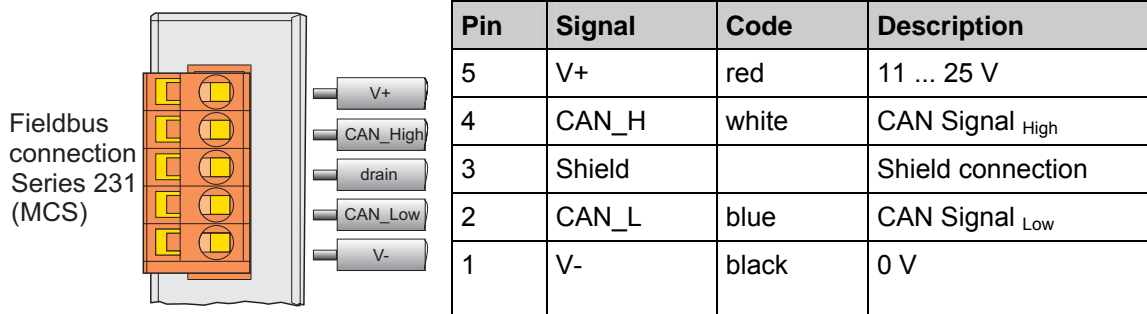

Fig. 3-3: Fieldbus connection, MCS

For the connection of small conductor cross sections, we recommend to insert an insulation stop from series 231-670 (white), 231-671 (light grey) or 231-672 (dark grey) due to the low kink resistance. This insulation stop prevents a conductor from kinking when it hits the conductor contact point, and as such the conductor insulation from also being entered into and clamped in the connection point. Connector marking and housing components, test connectors including cables and header connectors for cable extensions are available.

The connection point is lowered in such a way that after a connector is inserted, installation in an 80 mm high switchbox is possible.

The electrical isolation between the fieldbus system and the electronics is made via the DC/DC converter and the optocoupler in the fieldbus.

Display Elements

The operating condition of the fieldbus coupler or node is signalled via light diodes (LED).

Four LEDs specific for DeviceNet (OVERFL, RUN, BUSOFF, CONNECT) indicate the module status (MS) and the network status (NS).

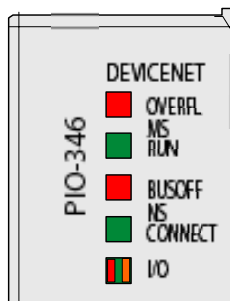

Fig. 3-4: Display elements

LED	Color	Meaning
OVERFL	red	Errors or faults at the fieldbus coupler.
RUN	green	Fieldbus coupler is ready for operation.
BUS OFF	red	Error or malfunction at network
CONNECT	green	Fieldbus coupler is ready for network communication.
I/O	red/ green/ orange	The ,I/O'-LED indicates the operation of the node and signals faults encountered.

Configuration Interface

The configuration interface used for the communication or for firmware transfer is located behind the cover flap.

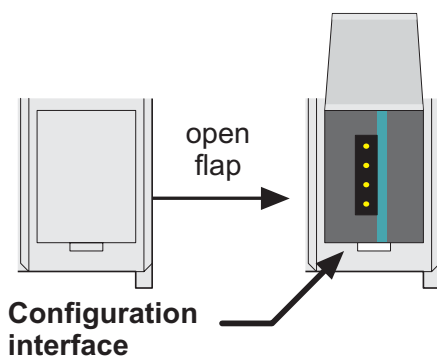

Fig. 3-5: Configuration interface

Hardware Address (MAC ID)

The DIP switch is used both for parametrizing (setting the baud rate) of the fieldbus coupler and for setting the MAC ID.

The MAC-ID (node address) is set with the DIP switches 1 to 6 by 'sliding' the desired DIP switch to 'ON'.

The binary significance of the individual DIP switches increases according to the switch number. DIP switch 1 being the lowest bit with the value 2^0 and switch 6 the highest bit with the value 2^5 . Therefore the MAC ID 1 is set with DIP1 = ON, the MAC ID 8 with DIP4 = ON, etc.

For the DeviceNet fieldbus nodes the node address can be set within the range from 0 to 63.

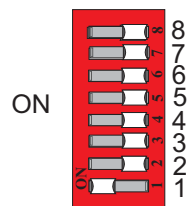

Fig. 3-6: Example: Setting of station (node) address MAC ID 1 (DIP 1 = ON)

The configuration is only read during the power up sequence. Changing the switch position during operation does not change the configuration of the buscoupler. Turn off and on the power supply for the fieldbus coupler to accept the DIP switch change.

The default setting is MAC ID 1.

Setting the Baud Rate

The bus coupler supports 3 different Baud rates, 125 kBaud, 250 kBaud and 500 kBaud. DIP switches 7 and 8 are used to set the baud rate.

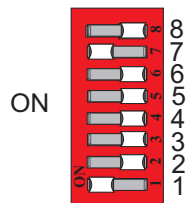

Fig. 3-7: Example: Setting the baud rate 250 kBaud (DIP 7 = ON) on a station (node) with the address MAC ID 1.

Baudrate	DIP7	DIP8
125 kBaud ^{*)}	OFF	OFF
250 kBaud	ON	OFF
500 kBaud	OFF	ON
not allowed	ON	ON

^{*)} Presetting

The configuration is only read during the power up sequence. Changing the switch position during operation does not change the configuration of the buscoupler. Turn off and on the power supply for the fieldbus coupler to accept the DIP switch change.

The default setting is Baud rate 125 kB.

3.1.3 Operating System

Following is the configuration of the master activation and the electrical installation of the fieldbus station.

After switching on the supply voltage, the coupler performs a self test of all functions of its devices, the I/O module and the fieldbus interface. Following this the I/O modules and the present configuration is determined, whereby an external not visible list is generated.

In the event of a fault the coupler changes to the "Stop" condition. The "I/O" LED flashes red. After clearing the fault and cycling power, the coupler changes to the "Fieldbus start" status and the "I/O" LED lights up green.

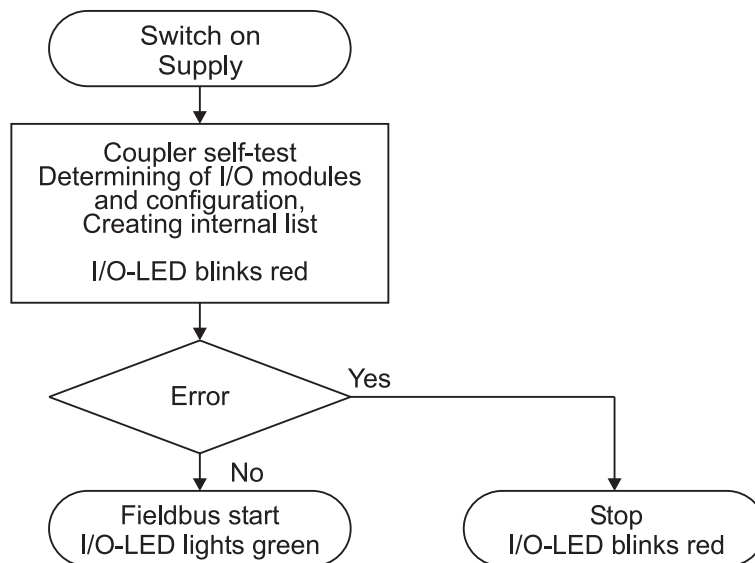

Fig. 3-8: Operating system - Power on

3.1.4 Process Image

After powering up, the coupler recognizes all I/O modules plugged into the node which supply or wait for data (data width/bit width > 0). In the nodes analog and digital I/O modules can be mixed.

The coupler produces an internal process image from the data width and the type of I/O module as well as the position of the I/O modules in the node. It is divided into an input and an output data area.

The data of the digital I/O modules is bit orientated, i.e. the data exchange is made bit for bit. The analog I/O modules are all byte orientated I/O modules, i.e. modules where the data exchange is made byte for byte. These I/O modules include for example the counter modules, I/O modules for angle and path measurement as well as the communication modules.



Note

For the number of input and output bits or bytes of the individual I/O modules please refer to the corresponding I/O module description.

The data of the I/O modules is separated for the local input and output process image in the sequence of their position after the coupler in the individual process image. In the respective I/O area, analog modules are mapped first, then all digital modules, even if the order of the connected analog and digital modules does not comply with this order. The digital channels are grouped, each of these groups having a data width of 1 byte. Should the number of digital I/Os exceed 8 bits, the coupler automatically starts another byte.

**Note**

A process image restructuring may result if a node is changed or extended. In this case the process data addresses also change in comparison with earlier ones. In the event of adding a module, take the process data of all previous modules into account.

3.1.5 Data Exchange

With DeviceNet, the transmission and exchange of data is made using objects.

For a network access on the single objects of the coupler, it is necessary to create a connection between the desired participants and to allocate connection objects.

For an easy and quick set-up of a connection the DeviceNet fieldbus coupler uses the "Predefined Master/Slave Connection Set", which contains 4 pre-defined connections. For the access on the coupler the connections only need to be allocated. The "Predefined Master/Slave Connection Set" confines itself to pure Master/Slave relationships.

The DeviceNet fieldbus coupler can only communicate via its assigned client and it is a so-called "Group 2 Only Server". The Group 2 Only Server communicating is only possible via the Group 2 Only Unconnected Explicit Message Port. These slaves exclusively receive messages defined in message group 2.

The object configuration for the data transmission is defined by an Assembly Object. The Assembly Object can be used to group data (e.g. I/O data) into blocks (mapping) and send this data via one single communication connection. This mapping results in a reduced number of accesses to the network.

A differentiation is made between "Input-Assemblies" and "Output-Assemblies".

An Input-Assembly reads in data from the application via the network or produces data on the network respectively.

An Output-Assembly writes data to the application or consumes data from the network respectively.

Various Assembly instances are permanently programmed (static assembly) in the fieldbus coupler.

**Further information**

The Assembly instances for the static assembly are described in chapter "Assembly Instances"

Communication Interfaces

For a data exchange, the DeviceNet fieldbus coupler is equipped with two interfaces:

- the interface to fieldbus (-master) and
- the interface to the bus modules.

Data exchange takes place between the fieldbus master and the bus modules.

Access from the fieldbus side is fieldbus specific.

Memory Areas

The coupler uses a memory space of 32 bytes for the physical input and 32 bytes for the physical output data.

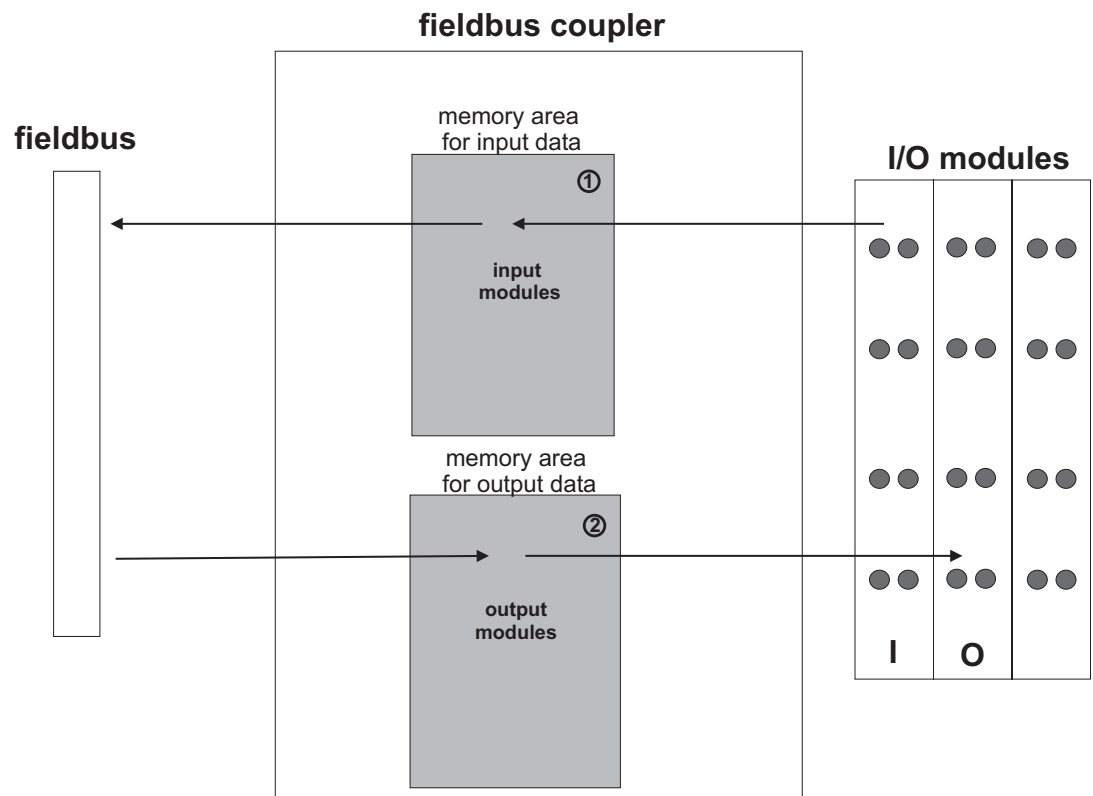

Fig. 3-9: Memory areas and data exchange for a fieldbus coupler

The coupler process image contains the physical data of the bus modules in a storage area for input data and in a storage area for output data (32 bytes each).

- ① The input module data can be read from the fieldbus side.
- ② In the same manner, writing to the output modules is possible from the fieldbus side.

Addressing

Fieldbus Specific

Once the supply voltage is applied, the Assembly Object maps data from the process image. As soon as a connection is established, a DeviceNet-Master (Scanner) can address and access the data by "Class", "Instance" and "Attribute". Data mapping depends on the selected Assembly Instance of the static Assembly.



Further information

The Assembly Instances of the static Assembly are described in chapter " Assembly Instances".

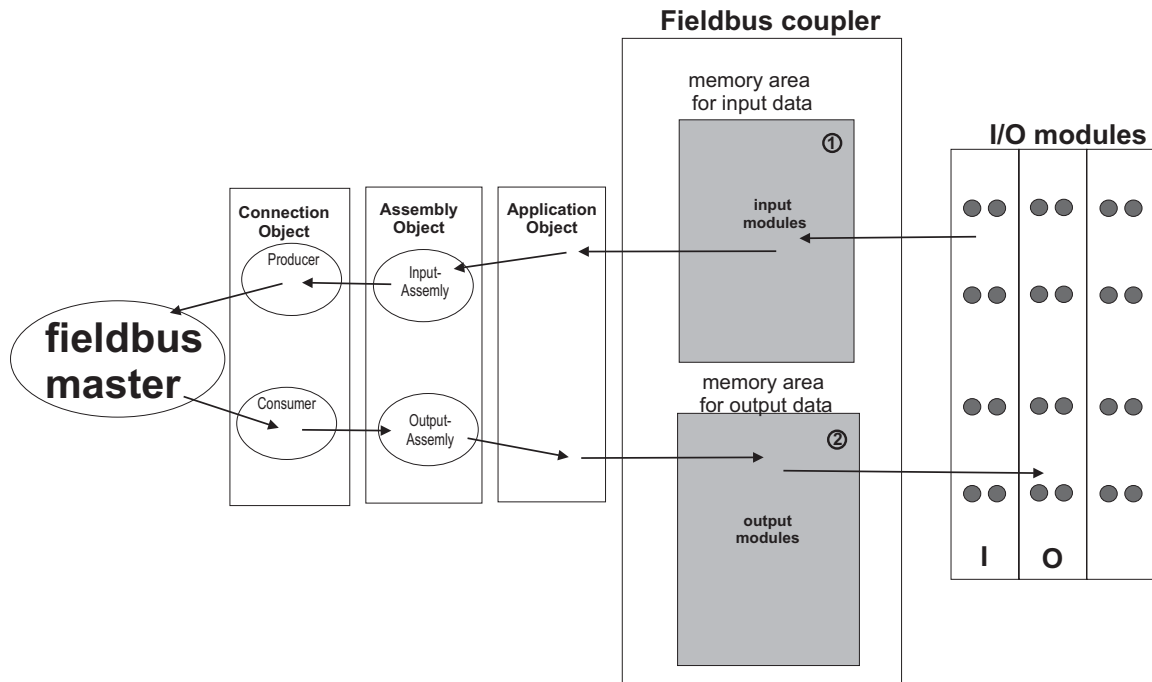

Fig. 3-1: Fieldbus specific data exchange for a DeviceNet fieldbus coupler



Note

For the number of input and output bits or bytes of the individual I/O modules, please refer to the corresponding I/O module description.



Note

A process image restructuring may result if a node is changed or extended. In this case the process data addresses also change in comparison with earlier ones. In the event of adding a module, take the process data of all previous modules into account.

Example for static assembly (default assembly):

The default assembly is:

Output1 (I/O Assembly Instance 1)
Input1 (I/O Assembly Instance 4)

In this example, the fieldbus node arrangement looks like this:

- 1) 1 ECO fieldbus coupler DeviceNet (PIO-346),
- 2) 1 digital 4-channel input modules (i. e. PIO-402),
- 3) 1 digital 4- channel output module (z. B. PIO-504),
- 4) 1 analog 2- channel output module with 2 bytes per channel (i. e. PIO-552),
- 5) 1 analog 2- channel input module with 2 bytes per channel (i. e. PIO-480),
- 6) 1 End module (PIO-600).

Input process image:

Default process data, input image (Assembly Class, Instance 4)

Byte	.7	.6	.5	.4	.3	.2	.1	.0
0	low byte channel 1							
1	high byte channel 1							
2	low byte channel 2							
3	high byte channel 2							
4	not used				DI04 ¹⁾	DI03 ¹⁾	DI02 ¹⁾	DI01 ¹⁾
5	DS08 ₂₎	DS07 ₂₎	DS06 ₂₎	DS05 ₂₎	DS04 ₂₎	DS03 ₂₎	DS02 ₂₎	DS01 ₂₎

¹⁾ DI = Digital Input

²⁾ DS = Diagnostic Status

Output process image:

Default process data, output image (Assembly Class, Instance 1)

Byte	.7	.6	.5	.4	.3	.2	.1	.0
0	low byte channel 1							
1	high byte channel 1							
2	low byte channel 2							
3	high byte channel 2							
4	not used				DO04 ¹⁾	DO03 ¹⁾	DO02 ¹⁾	DO01 ¹⁾

¹⁾ DO = Digital Output

3.1.6 Configuration Software

To enable a connection between the PLC and the fieldbus devices, the interface modules have to be configured with the individual station data.

3.1.7 Starting up DeviceNet Fieldbus Nodes

This chapter shows the step-by-step procedure for starting up a PARKER DeviceNet fieldbus node.



Attention

This description is given as an example and is limited to the execution of a local start-up of an individual DeviceNet fieldbus node.

The procedure contains the following steps:

Connecting the PC and fieldbus node

Setting the MAC ID and baud rate

1. Configuration with static Assembly

Connecting the PC and Fieldbus Node

1. Connect the fitted DeviceNet fieldbus node to the DeviceNet fieldbus PCB in your PC via a fieldbus cable.
The 24 V field bus supply is fed by an external fieldbus network power supply over the connections V+, V- of the 5-pin fieldbus connector (MCS Series 231).
2. Start your PC.

Setting the MAC ID and Baud Rate

3. Use the DIP switches 1...6 to set the desired node address (MAC ID). The binary significance of the individual DIP switches increases according to the switch number.

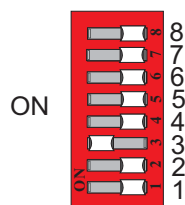

Fig. 3-10: Example: Setting the MAC ID 4 (DIP 3 = ON).

DIP switch	Value
1	2^0
2	2^1
3	2^2
4	2^3
5	2^4
6	2^5

DIP switches 7 and 8 are used to set the desired baud rate.

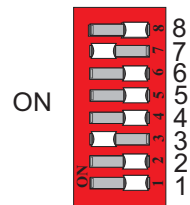

Fig. 3-11: Example: Setting the baud rate 250 kBaud (DIP 7 = ON) of the station with MAC ID 1.

Baud rate	DIP7	DIP8
125 kBaud ^{*)}	OFF	OFF
250 kBaud	ON	OFF
500 kBaud	OFF	ON
not allowed	ON	ON

^{*)} Presetting

4. Then switch on the coupler supply voltage.

3.1.8 LED Display

The coupler possesses several LEDs for on site display of the coupler operating status or the complete node.

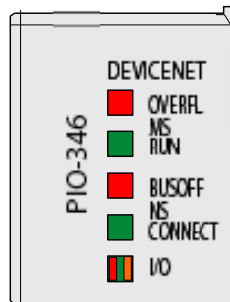

Fig. 3-12: Display elements

The module status (MS) and the network status (NS) can be displayed by the top 4 LED's. They react as described in the table.

Module status			
OVERFL (red)	RUN (green)	State of device	Meaning
off	off	no power	No power supply to the device.
off	on	device operational	The device operates correctly.
off	blinking	device in standby	The device needs to be configured or has been partly configured.
blinking	off	minor fault	A minor fault has occurred. It exists a diagnostics.
on	off	unrecoverable fault	The device is defective, needs to be serviced or replaced.
blinking	blinking	device self testing	The device performs a built-in check.

Table 3-1: Fault and status displays: MS

Network status			
BUSOFF (red)	CONNECT (green)	State of device	Meaning
off	off	not powered, not online	No power supply to the device / fieldbus supply / DeviceNet cable not connected and „Duplicate MAC ID detection“ is not yet completed.
off	blinking	online, not connected	The device operates correctly at the fieldbus. However, it has not yet been integrated by a scanner.
off	on	link ok online, connected	The device operates correctly at the fieldbus. At least one connection to another device has been established.
blinking	off	connection time out	A minor fault has occurred.
on	off	critical link failure	The device has detected a fault. It is unable to perform any more functions in the network.

Table 3-2: Fault and status displays: NS

Node Status

LED	Color	Meaning
I/O	red /green / orange	The 'I/O' LED indicates the node operation and signals faults occurring.

The coupler starts after switching on the supply voltage. The "I/O" LED flashes red. Following an error free start up the "I/O" LED changes to green steady light. In the case of a fault the "I/O" LED continues blinking red. The fault is cyclically displayed with the blink code.

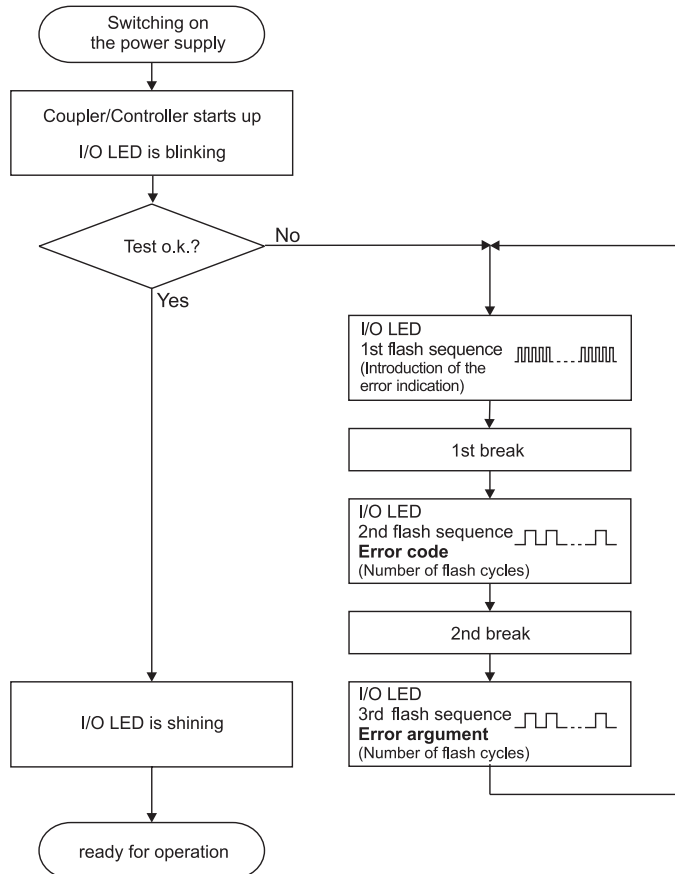

Fig. 3-13: Signalling the LED's node status

After overcoming a fault, restart the coupler by cycling the power.

I/O	Meaning
green	Data cycle on the internal bus
off	No data cycle on the internal bus
red	Coupler hardware defective
red blinks	When starting: internal bus is initialized During operation: general internal bus fault
red blinks cyclically	Fault message during internal bus reset and internal fault:

Blink Code

Detailed fault messages are displayed with the aid of a blink code. A fault is cyclically displayed with up to 3 blink sequences.

- The first blink sequence (approx. 10 Hz) starts the fault display.
- The second blink sequence (approx. 1 Hz) following a pause. The number of blink pulses indicates the **fault code**.
- The third blink sequence (approx. 1 Hz) follows after a further pause. The number of blink pulses indicates the **fault argument**.

Fault Message via the Blink Code of the I/O LED

Fault argument	Fault description
Fault code 1: Hardware and configuration fault	
0	EEPROM check sum fault / check sum fault in parameter area of the flash memory
1	Overflow of the internal buffer memory for the inline code
2	Unknown data type
3	Module type of the flash program memory could not be determined / is incorrect
4	Fault during writing in the flash memory
5	Fault when deleting the FLASH memory
6	Changed I/O module configuration found after AUTORESET
7	Invalid firmware
8	Timeout error serial EPROM
Fault code 2: Additional Configuration fault	
1	Process image is inactive at the switching operation Control or Monitor mode
2	Process image is bigger than the available cache
3	Error by the process image compilation
Fault code 3: Internal bus command fault	
0	I/O module(s) has (have) identified internal bus command as incorrect
Fault code 4: Internal bus data fault	
0	Data fault on internal bus or Internal bus interruption on coupler
n* (n>0)	Internal bus interrupted after I/O module n
Fault code 5: Register communication fault	
n*	Internal bus fault during register communication with the I/O module n
Fault code 6: Fieldbus specific fault	
0	Number of I/O modules is exceeded, the Process image is bigger than the available cache
Fault code 7: I/O module not supported	
n*	I/O module not supported at position n

Fault code 8: not used	
-	Fault code 8 is not used.
Fault code 9: CPU-TRAP-error	
-	Fault code 9 is not used.

* The number of blink pulses (n) indicates the position of the I/O module. I/O modules without data are not counted (i.e. supply module without diagnosis)

Example: the 13th I/O module is removed.	
1.	The "I/O" LED generates a fault display with the first blink sequence (approx. 10 Hz).
2.	The first pause is followed by the second blink sequence (approx. 1 Hz). The "I/O" LED blinks four times and thus signals the fault code 4 (internal bus data fault).
3.	The third blink sequence follows the second pause. The "I/O" LED blinks twelve times. The fault argument 12 means that the internal bus is interrupted after the 12 th I/O module.

3.1.9 Technical Data

System data	
Max. no. of nodes	64 with scanner
Max. no. of I/O points	ca. 6000 (depends on master)
Transmission medium	shielded Cu cable, trunk line: AWG 15, 18 (2x 0.82mm ² +2x1.7mm ²) drop line: AWG 22, 24 (2x0.2mm ² +2x0.32mm ²)
Max. length of bus line	100 m ... 500 m (depends on baud rate / on the cable)
Baud rate	125 kBaud, 250 kBaud, 500 kBaud
Buscoupler connection	5-pole male connector, series 231 (MCS) female connector 231-305/010-000/050-000 is included
Standards and approvals	
UL	E198563, UL508
Conformity marking	CE
Technical data	
Max. number of I/O modules	64
Fieldbus	
Input process image	max. 32 Byte
Output process image	max. 32 Byte
Configuration	via PC or PLC
Voltage supply	DC 24 V (-15 % / + 20 %)
Current consumption	
- via power supply terminal <small>typ.</small> at nominal load	260 mA at 24 V
- via DeviceNet interface	<120 mA at 11 V
Efficiency of the power supply <small>typ.</small> at nominal load	80 %
Internal current consumption	350 mA at 5 V
Total current for I/O modules	650 mA at 5 V
Dimensions (mm) W x H x L	50 x 65* x 97 (*from top edge of mounting rail)
Weight	ca. 120 g
EMC interference resistance	gem. EN 50082-2 (96)
EMC interference transmission	gem. EN 50081-2 (94)

4 I/O modules

4.1 PIO-400 [2 DI DC 24 V 3.0 ms, high-side switching]

2-Channel Digital Input Module DC 24 V 3.0 ms,
2-, 3- or 4-conductor connection; high-side switching

4.1.1 View

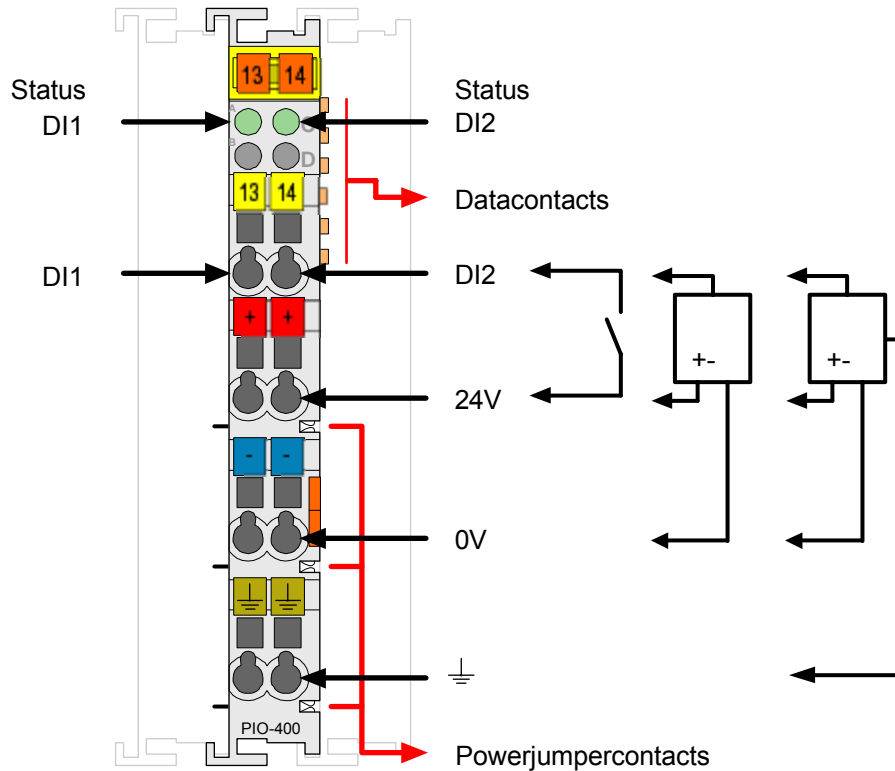

Fig. 4.1.1-1: 2-Channel Digital Input Module PIO-400

4.1.2 Description

The digital input module PIO-400 receives control signals from digital field devices (sensors, switches, etc.).

The module is a 2- to 4-conductor device and has two input channels. Two sensors may be directly connected to the module.

Two 4-conductor sensors with ground (earth) wire may be directly connected to 24 V, 0 V, PE (earth potential), signal input DI 1 or signal input DI 2.

Each input module has an RC noise rejection filter with a time constant of 3.0 ms.

The status of the input channels is indicated via status LEDs.

An optocoupler is used for electrical isolation between the bus and the field side.

Any configuration of the input modules is possible when designing the fieldbus node.

Grouping of module types is not necessary.

The field side supply voltage of 24 V for the input module is derived from adjacent I/O modules or from a supply module. The supply voltage for the field side is made automatically through the individual I/O modules by means of power jumper contacts.

The digital input module can be used with all couplers/controllers of the PARKER-I/O-SYSTEM PIO.

4.1.3 Display Elements

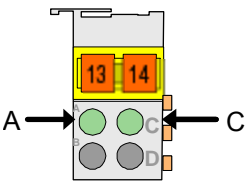

Fig. 4.1.3-1: Display Elements

LED	Channel	Designation	State	Function
A green	1	Status DI 1	off	Input DI 1: Signal voltage (0)
			on	Input DI 1: Signal voltage (1)
C green	2	Status DI 2	off	Input DI 2: Signal voltage (0)
			on	Input DI 2: Signal voltage (1)

4.1.4 Schematic Diagram

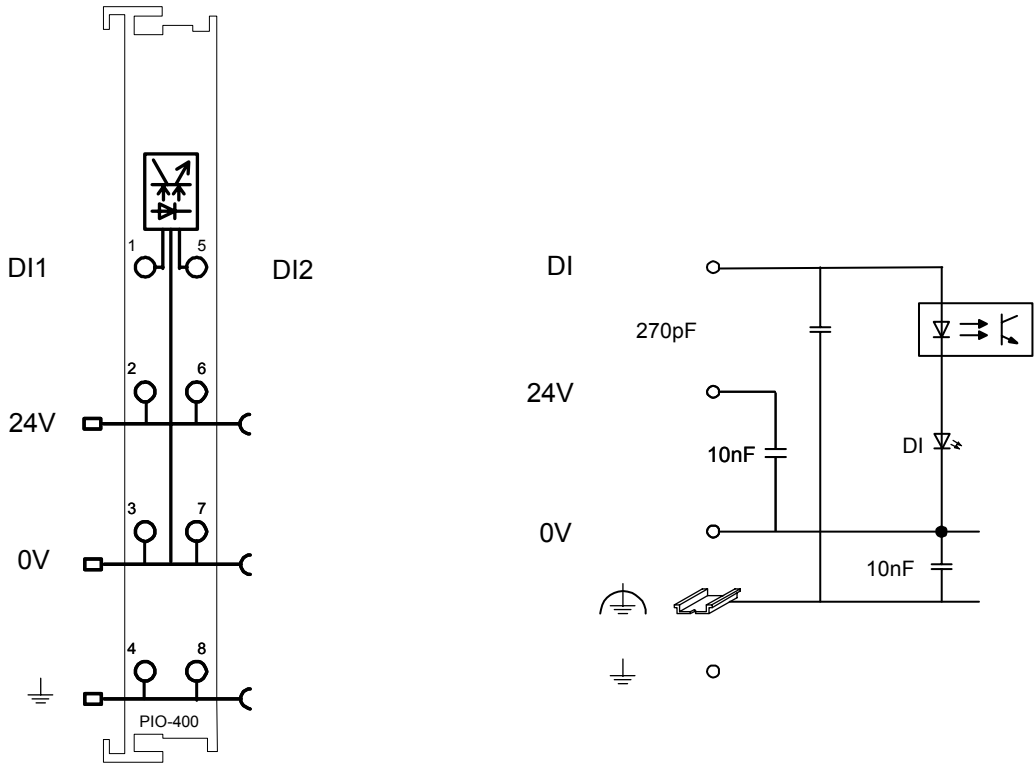

Fig. 4.1.4-1: 2-Channel Digital Input Module PIO-400

4.1.5 Technical Data

Module Specific Data	
Number of inputs	2
Current consumption (internal)	3.7 mA
Nominal voltage	DC 24 V (-15 % / +20%)
Signal voltage (0)	DC -3 V to +5 V
Signal voltage (1)	DC 15 V to 30 V
Input filter	3.0 ms
Current supply <small>typ.</small>	4.5 mA
Isolation	500 V _{eff} (Field/System)
Internal bit width	2 Bit
Weight	ca. 50 g
Approvals	
UL	E198563, UL508
KEMA	01ATEX1024 X II 3 G EEx nA II T4
GL (Germanischer Lloyd)	40 197-01 HH Cat. A, B, C, D
LR (Lloyd's Register)	02/20026 Env. 1, 2, 3, 4
DNV (Det Norske Veritas)	A-8471 Cl. B
RINA (Registro Italiano Navale)	MAC30402CS1
ABS (American Bureau of Shipping)	03-HG374860-PDA
Conformity marking	CE

4.1.6 Process Image

Input bit	B1	B0
Meaning	Signal status DI 2 – Channel 2	Signal status DI 1 – Channel 1

4.2 PIO-402 [4 DI DC 24 V 3.0 ms, high-side switching]

4- Channel Digital Input Module DC 24 V 3.0 ms,
2- or 3- conductor connection; high-side switching

4.2.1 View

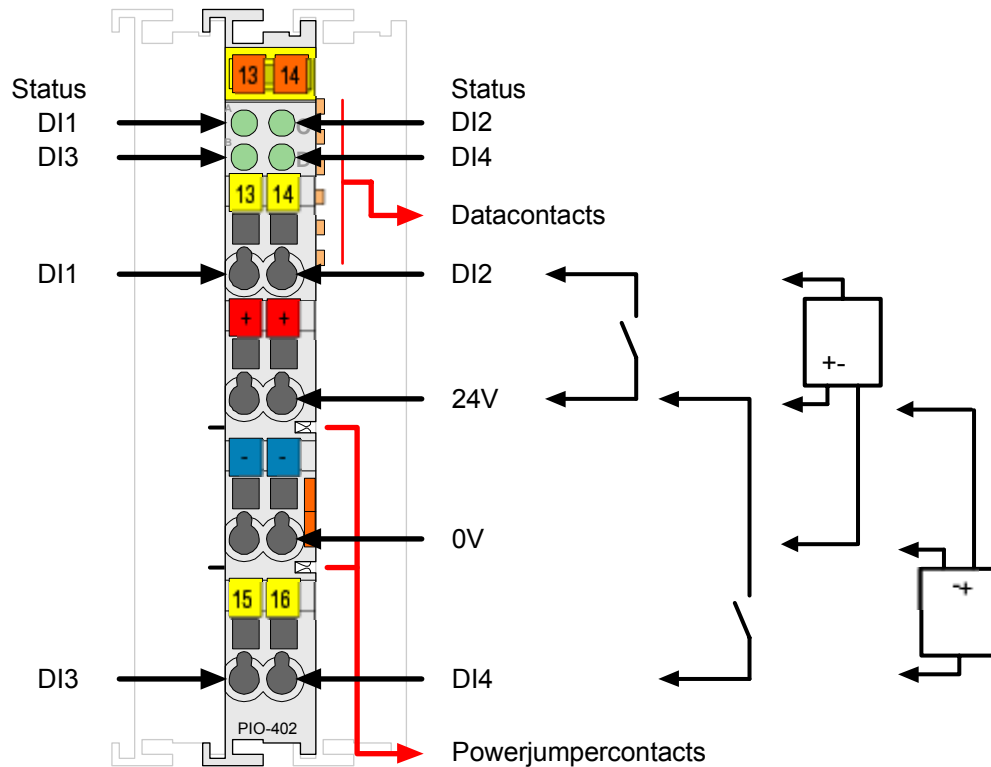

Fig. 4.2.1-1: 4- Channel Digital Input Module PIO-402

4.2.2 Description

The digital input module PIO-402 receives control signals from digital field devices (sensors, switches, etc.).

The module is a 2- to 3-conductor device and has 4 input channels. Two sensors may be directly connected to the module.

As an example, two 3-conductor sensors can be directly connected using connection 24V, 0V and signal input DI1 or DI2.

Each input module has an RC noise rejection filter with a time constant of 3.0 ms.

The status of the input channels is indicated via status LEDs.

An optocoupler is used for electrical isolation between the bus and the field side.

Any configuration of the input modules is possible when designing the fieldbus node. Grouping of module types is not necessary.

The field side supply voltage of 24V for the input module is derived from adjacent I/O modules or from a supply module. The supply voltage for the field side is made automatically through the individual I/O modules by means of power jumper contacts. The digital input module can be used with all couplers/controllers of the PARKER-I/O-SYSTEM PIO.

4.2.3 Display Elements

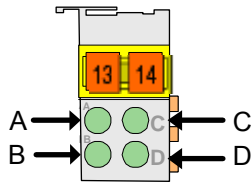

Fig. 4.2.3-1: Display Elements

LED	Channel	Designation	State	Function
A green	1	Status DI 1	off	Input DI 1: Signal voltage (0)
			on	Input DI 1: Signal voltage (1)
C green	2	Status DI 2	off	Input DI 2: Signal voltage (0)
			on	Input DI 2: Signal voltage (1)
B green	3	Status DI 3	off	Input DI 3: Signal voltage (0)
			on	Input DI 3: Signal voltage (1)
D green	4	Status DI 4	off	Input DI 4: Signal voltage (0)
			on	Input DI 4: Signal voltage (1)

4.2.4 Schematic Diagram

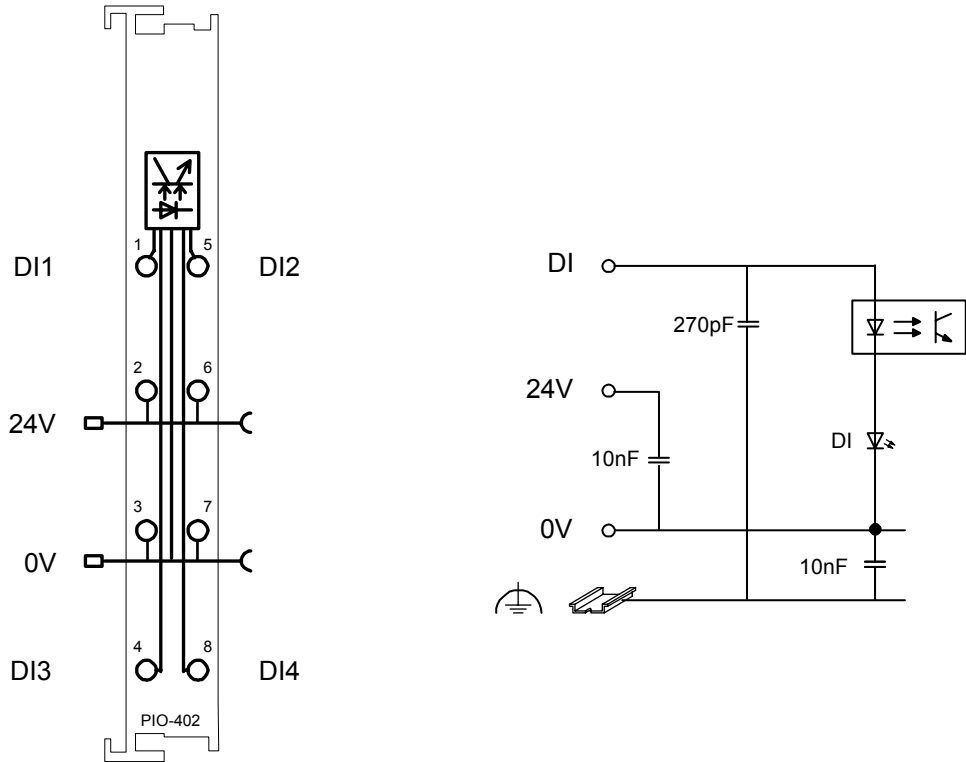

Fig. 4.2.4-1: 4-Channel Digital Input Module PIO-402

4.2.5 Technical Data

Module Specific Data	
Number of inputs	4
Current consumption (internal)	7.5 mA
Nominal voltage	DC 24 V (-15 % / +20 %)
Signal voltage (0)	DC -3 V to +5 V
Signal voltage (1)	DC 15 V to 30 V
Input filter	3.0 ms
Current supply <small>typ.</small>	4.5 mA
Isolation	500 V _{eff.} (Field/System)
Internal bit width	4 Bit
Weight	ca. 50 g
Approvals	
UL	E198563, UL508
KEMA	01ATEX1024 X II 3 G EEx nA II T4
GL (Germanischer Lloyd)	40 197-01 HH Cat. A, B, C, D
LR (Lloyd's Register)	02/20026 Env. 1, 2, 3, 4
DNV (Det Norske Veritas)	A-8471 Cl. B
RINA (Registro Italiano Navale)	MAC30402CS1
ABS (American Bureau of Shipping)	03-HG374860-PDA
Conformity marking	CE

4.2.6 Process Image

Input bit	B3	B2	B1	B0
Meaning	Signal status DI 4 – Channel 4	Signal status DI 3 – Channel 3	Signal status DI 2 – Channel 2	Signal status DI 1 – Channel 1

4.3 PIO-430 [8 DI DC 24 V 3.0 ms, high-side switching]

8-Channel Digital Input Module DC 24 V 3.0 ms,
1-conductor connection; high-side switching

4.3.1 View

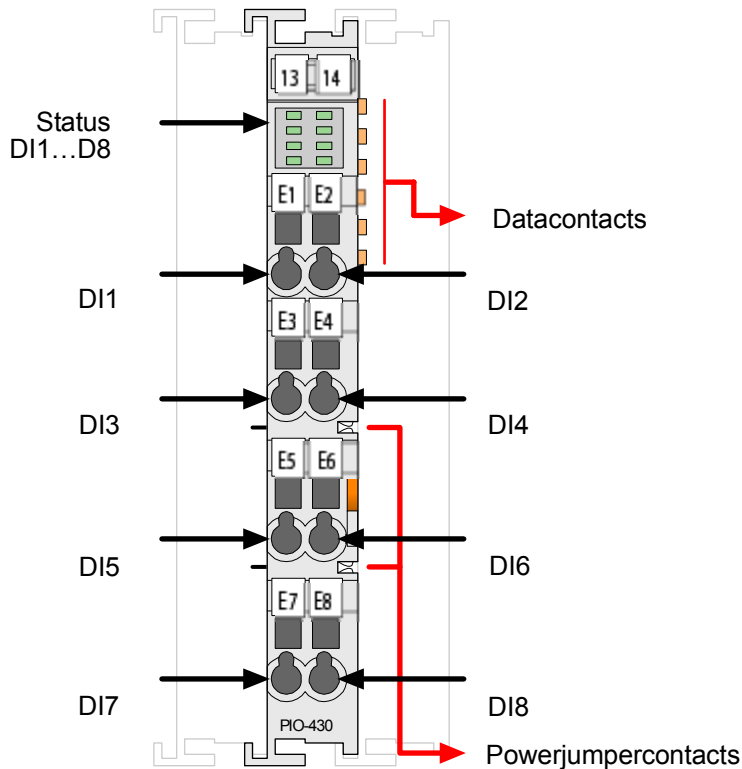

Fig. 4.3.1-1: 8-Channel Digital Input Module PIO-430

4.3.2 Description

The digital input module PIO-430 receives control signals from digital field devices (sensors, switches, etc.).

The module is a 1-conductor device and has eight input channels. Eight 1-conductor sensors may be directly connected to signal input DI 1, ... DI 8.

Each input module has an RC noise rejection filter with a time constant of 3.0 ms.

All inputs are isolated.

The status of the input channels is indicated via status LEDs.

An optocoupler is used for electrical isolation between the bus and the field side.

Any configuration of the input modules is possible when designing the fieldbus node. Grouping of module types is not necessary.



Note

The module possesses power jumper contacts to pass through supply voltage for the field side to the following modules.

The field side supply voltage of 24V for the input module is derived from adjacent I/O modules or from a supply module. The supply voltage for the field side is made automatically through the individual I/O modules by means of power jumper contacts. The digital input module can be used with all couplers/controllers of the PARKER-I/O-SYSTEM PIO.

4.3.3 Display Elements

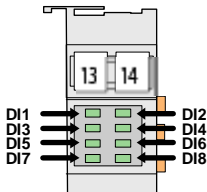

Fig. 4.3.3-1: Display Elements

LED	Channel	Designation	State	Function
green	1	Status DI 1	off	Input DI 1: Signal voltage (0)
			on	Input DI 1: Signal voltage (1)
green	2	Status DI 2	off	Input DI 2: Signal voltage (0)
			on	Input DI 2: Signal voltage (1)
green	3	Status DI 3	off	Input DI 3: Signal voltage (0)
			on	Input DI 3: Signal voltage (1)
green	4	Status DI 4	off	Input DI 4: Signal voltage (0)
			on	Input DI 4: Signal voltage (1)
green	5	Status DI 5	off	Input DI 5: Signal voltage (0)
			on	Input DI 5: Signal voltage (1)
green	6	Status DI 6	off	Input DI 6: Signal voltage (0)
			on	Input DI 6: Signal voltage (1)
green	7	Status DI 7	aus	Input DI 7: Signal voltage (0)
			on	Input DI 7: Signal voltage (1)
green	8	Status DI 8	off	Input DI 8: Signal voltage (0)
			on	Input DI 8: Signal voltage (1)

4.3.4 Schematic Diagram

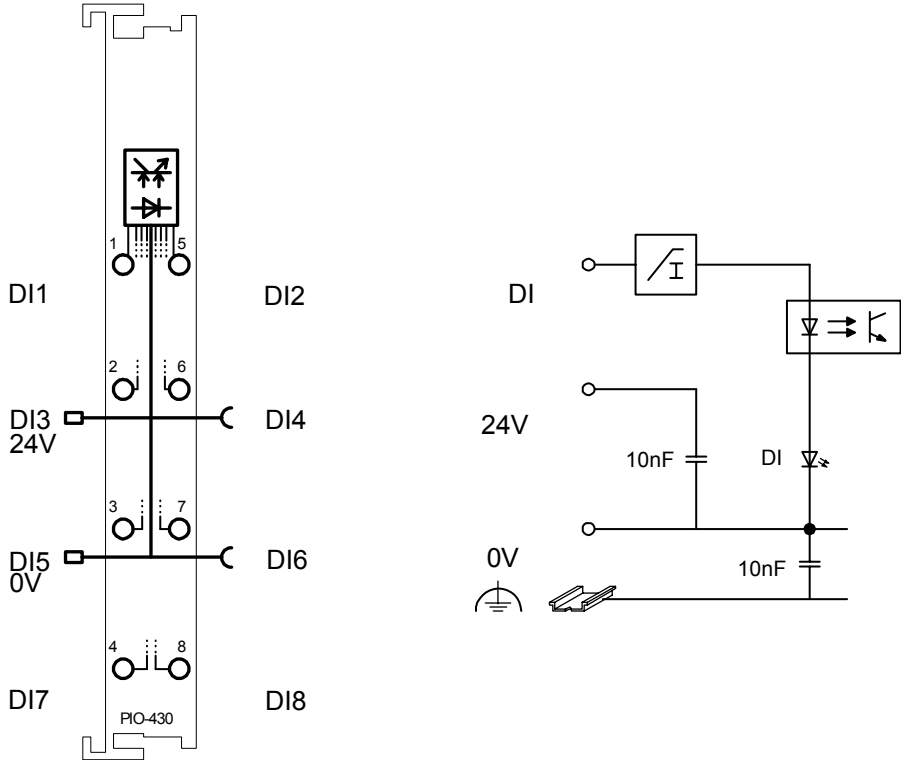

Fig. 4.3.4-1: 8-Channel Digital Input Module PIO-430

4.3.5 Technical Data

Module Specific Data	
Number of inputs	8
Current consumption (internal)	17 mA
Signal voltage (0)	DC -3 V to +5 V
Signal voltage (1)	DC 15 V to 30 V
Input filter	3.0 ms
Current supply <small>typ.</small>	2.8 mA
Isolation	500 V _{eff} (Field/System)
Internal bit width	8 Bit
Weight	ca. 50 g
Approvals	
UL	E198563, UL508
DEMKO	02 ATEX 132273 X II 3 GD EEx nA II T4
Conformity marking	CE

4.3.6 Process Image

Input bit	B7	B6	B5	B4	B3	B2	B1	B0
Meaning	Signal status DI 8 – Channel 8	Signal status DI 7 – Channel 7	Signal status DI 6 – Channel 6	Signal status DI 5 – Channel 5	Signal status DI 4 – Channel 4	Signal status DI 3 – Channel 3	Signal status DI 2 – Channel 2	Signal status DI 1 – Channel 1

4.4 PIO-468 [4 AI DC 0-10 V, Single-Ended]

4-Channel Analog Input Module (0-10V, Single-Ended)

4.4.1 View

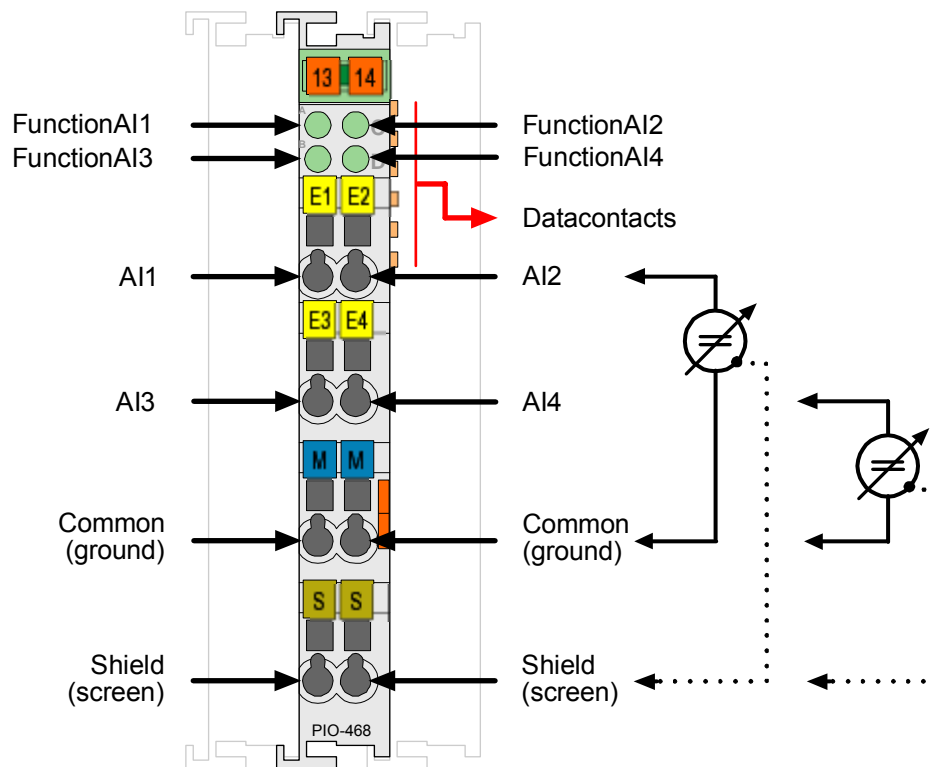

Fig. 4.4.1-1: 4-Channel Analog Input Module PIO-468

4.4.2 Description

The analog input module receives signals with the standardized values of 0-10 V. The module has four input channels. As an example, the fieldside signals may be received via the connections AI 1 and Common (ground) or AI 2 and Common (ground). The connection of more sensors to signal inputs AI 3 and AI 4 requires a suitable measure for the Common (ground) and the Shield (screen) connection, if need be.

The input channels of a module have a common ground and a shield (screen) connection (S). The Shield (screen) is directly connected to the DIN rail.

A capacitive connection is made automatically when snapped onto the DIN rail.

The input signal of each channel is electrically isolated and will be transmitted with a resolution of 12 bits.

The operational readiness and the trouble-free internal data bus communication of the channels are indicated via a green function LED.

Any configuration of the input modules is possible when designing the fieldbus node.

Grouping of module types is not necessary

The voltage supply is done via system voltage.



Attention

This module has no power contacts. For field supply to downstream I/O modules, a supply module will be needed.

The analog input module can be used with all couplers/controllers of the PARKER-I/O-SYSTEM PIO.

4.4.3 Display Elements

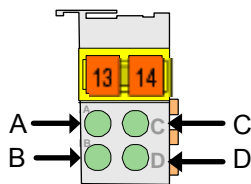

Fig. 4.4.3-1: Display Elements

LED	Channel	Designation	State	Function
A green	1	Function AI 1	off	No operational readiness or the internal data bus communication is interrupted
			on	Operational readiness and trouble-free internal data bus communication
C green	2	Function AI 2	off	No operational readiness or the internal data bus communication is interrupted
			on	Operational readiness and trouble-free internal data bus communication
B green	3	Function AI 3	off	No operational readiness or the internal data bus communication is interrupted
			on	Operational readiness and trouble-free internal data bus communication
D green	4	Function AI 4	off	No operational readiness or the internal data bus communication is interrupted
			on	Operational readiness and trouble-free internal data bus communication

4.4.4 Schematic Diagram

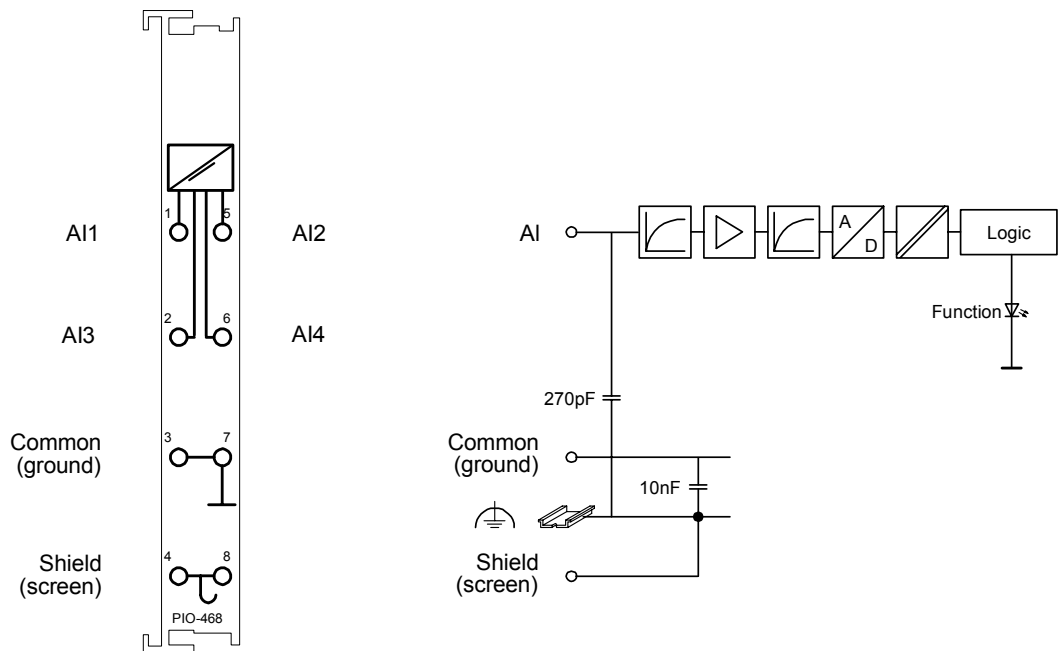

Fig. 4.4.4-1: 4-Channel Analog Input Module PIO-468

4.4.5 Technical Data

Module Specific Data	
Number of inputs	4
Voltage supply	via system voltage DC /DC
Current consumption _{typ.} (internal)	60 mA
Input voltage _{max.}	35 V
Signal voltage	0 V... 10 V
Internal resistance _{typ.}	133 kΩ
Resolution	12 Bit
Conversion time _{typ.}	4 ms
Measuring error _{25 °C}	<± 0,2 % of the full scale value
Temperature coefficient	<± 0,01 % /K of the full scale value
Isolation	500 V _{eff} (system/supply)
Bit width	4 x 16 bits data 4 x 8 bits control / status(option)
Weight	ca. 55 g
Approvals	
UL	E198563, UL508
KEMA	01ATEX1024 X II 3 G EEx nA II T4
GL (Germanischer Lloyd)	40 197-01 HH Cat. A, B, C, D
LR (Lloyd's Register)	02/20026 Env. 1, 2, 3, 4
DNV (Det Norske Veritas)	A-8471 Cl. B
RINA (Registro Italiano Navale)	MAC30402CS1
ABS (American Bureau of Shipping)	03-HG374860-PDA
Conformity marking	CE

4.4.6 Process Image

The analog input module PIO-468 transmit 16-bit measured values and 8 status bits per channel.

The digitalized measured value is transmitted in a data word (16 bits) as input byte 0 (low) and input byte 1 (high) into the process image of the coupler / controller.

This value is represented with a 12 bit resolution on bit B3 ... B14.

From the manufacturing number [32]02[XX][XX] onwards, the status information included in the three least significant bits (B0 ... B2) can be parsed in the event of an error. Bit B0 = 1 is set when the range of measurement is overranged.

For modules having a previous manufacturing number, the last 3 bits are not parsed.

The manufacturing number is part of the lateral marking on the module enclosure.

Some fieldbus systems can process input channel status information by means of a status byte.

However, the coupler / controller process operation is optional, which means that accessing or parsing the status information depends on the fieldbus system.

**Attention**

The representation of the process data of some fieldbus modules in the process image depends on the fieldbus coupler/-controller used. Please take this information as well as the particular design of the respective control/status bytes from the section "Fieldbus specific design of the process data" included in the description of the process image of the corresponding coupler/ controller.

4.4.7 Standard Format

For the standard module PIO-468, the input voltage ranging from < 0 V to > 10 V is scaled on the numerical values ranging from 0x0000 to 0x7FF9.

Process values of module PIO-468						
Input current 0 - 10 V	numerical value				status- byte hex.	
	binary value	* ₁) X F Ü	hex.	dec.		
0	0000 0000 0000 0	000	00 00	0	00	
5	0100 0000 0000 0	000	40 00	16384	00	
10	0111 1111 1111 1	000	7F F8	32760	00	
> 10	0111 1111 1111 1	001	7F F9	32761	42	

*₁) status bits: X = not used, F = short-circuit, Ü = oversize

4.5 PIO-480 [2 AI 0-20 mA Differential Measurement Input]

2-Channel Analog Input Module 0-20 mA,
differential measurement input

4.5.1 View

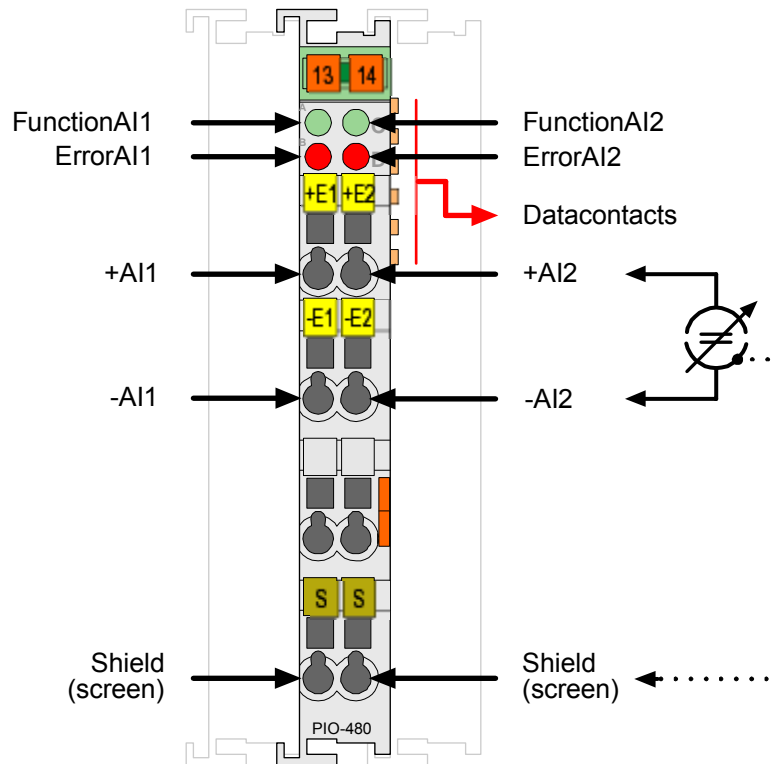

Fig. 4.5.1-1: 2-Channel Analog Input Module 0-20 mA

4.5.2 Description

The analog input module receives differential signals of values 0-20 mA.

The module has two differential input channels and can receive differential signals via the connections +AI 1 and -AI 1 or +AI 2 and -AI 2.

The shield (screen) is directly connected to the DIN rail. A capacitive connection is made automatically when snapped onto the DIN rail.

The input signal of each channel is electrically isolated and will be transmitted with a resolution of 13 bits.

The operational readiness and trouble-free internal data bus communication of the channels are indicated via a Function LED. Overrange or underflow of the measuring range is indicated via an Error LED.

Any configuration of the input modules is possible when designing the fieldbus node. Grouping of module types is not necessary.

The voltage supply is done via system voltage.



Attention

This module has no power contacts. For field supply to downstream I/O modules, a supply module will be needed.

The analog input module can be used with all couplers/controllers of the PARKER-I/O-SYSTEM PIO.

4.5.3 Display Elements

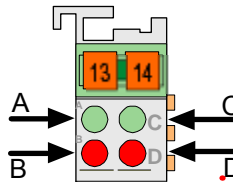

Fig. 4.5.3-1: Display Elements

LED	Channel	Designation	State	Function
A green	1	Function AI 1	off	No operational readiness or the internal data bus communication is interrupted
			on	Operational readiness and trouble-free internal data bus communication
B red		Error AI 1	off	Normal operation
			on	Overrange/underflow of the admissible measuring range
C green	2	Function AI 2	off	No operational readiness or the internal data bus communication is interrupted
			on	Operational readiness and trouble-free internal data bus communication
D red		Error AI 2	off	Normal operation
			on	Overrange/underflow of the admissible measuring range

4.5.4 Schematic Diagram

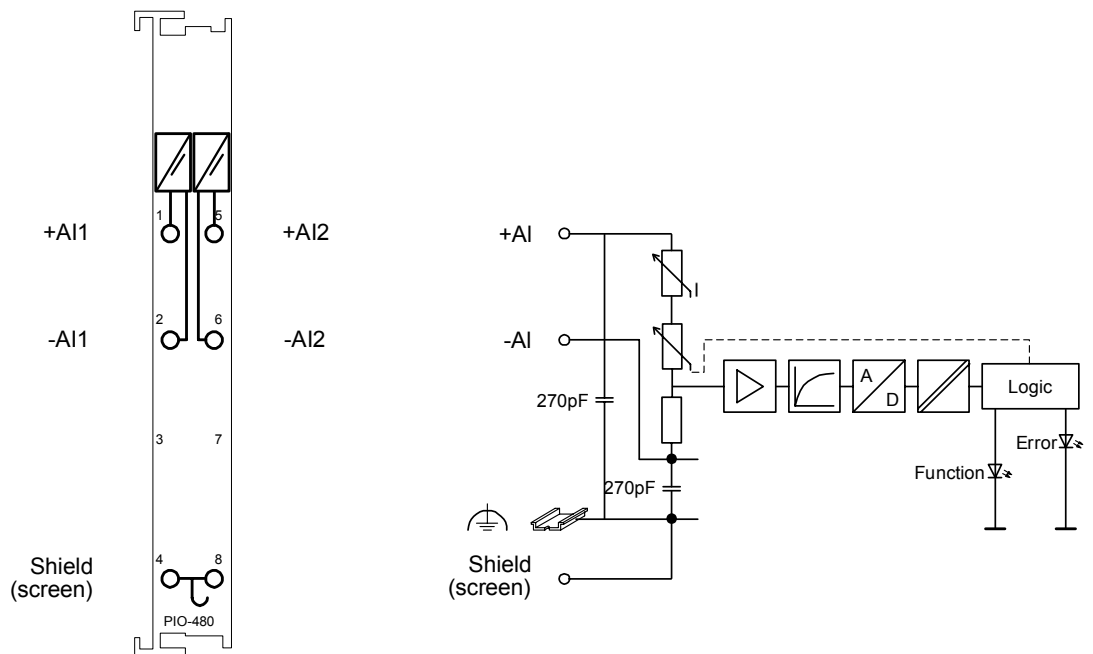

Fig. 4.5.4-1: 2-Channel Analog Input Module 0-20 mA

4.5.5 Technical Data

Module Specific Data	
Number of outputs	2, electrically isolated from each other
Measured-value acquisition	time synchronous (both inputs)
Voltage supply	via system voltage DC /DC
Current consumption (internal)	≤ 100 mA
Signal current	0 ... 20 mA
Internal resistance	< 270 Ω at 20 mA
Overrange/ measuring range underflow	status byte and LED
Input filter	low pass first order, fG = 5 kHz
Resolution of the A/D converter	14 Bit
Monotonicity without missing codes	yes
Resolution of the measured value	13 Bit
Value of a LSB (Bit 2) (Least Significant Bit)	2.4 µA
Measuring error _{25 °C}	≤ ±0.05% of the full scale value
Temperature coefficient	< ±0.01%/K of the full scale value
Measuring error	≤ 0.4 % over whole temperature range ≤ 0.1 % of upper range value (non-linearity)
Crosstalk attenuation	≥ 80 db
Sampling time of repetition	1 ms
Sampling delay (module)	1 ms
Sampling delay (channel/channel)	≤ 1 µs
Sampling duration	≤ 5 µs
Method of conversion	SAR (Successive Approximation Register)
Operating mode	continuously sampling (preset)
Protection	non-linear limiting
Admissible continuous overload	30 V
Voltage resistance	DC 500V channel/channel or channel/system
Bit width	2 x 16 bits data 2 x 8 Bit bits control/status (option)
Weight	ca. 55 g
Approvals	
UL	E198563, UL508
DEMKO	02 ATEX 132273 X II 3 GD EEx nA II T4
Conformity marking	CE

4.5.6 Process Image

The analog input module PIO-480 transmits 16-bit measured values and 8 optional status bits per channel.

The digitalized measured value is transmitted in a data word (16 bits) as input byte 0 (low) and input byte 1 (high) into the process image of the coupler / controller.

This value is represented with a 13 bit resolution on bit B2 ... B14.

The most significant bit15 (MSB) is always '0'.

The states of the first two least significant bits B0 and B1 are not defined in the range between 0 and 20 mA. Therefore, they are represented with a 'X' in the table.

The hexadecimal and decimal measured values are listed in the table provided that the first two bits have the state '0'. If the state '1' is taken into consideration for both bits, the decimal measured value will be higher by the value 3 as it is indicated in the table.

Some fieldbus systems can process input channel status information by means of a status byte.

However, processing via the coupler / controller is optional, which means that accessing or parsing the status information depends on the fieldbus system.



Attention

The representation of the process data of some I/O modules in the process image depends on the fieldbus coupler/-controller used. Please take this information as well as the particular design of the respective control/status bytes from the section "Fieldbus Specific Design of the Process Data" included in the description concerning the process image of the corresponding coupler/controller.

4.5.7 Standard Format

For the standard module PIO-480, the input current ranging from < 0 mA to > 20 mA is scaled on the numerical values ranging from 0x0000 to 0x7FFF.

Process values of module PIO-480					
Input current 0 - 20 mA	numerical value			status- byte hex.	LED error AI 1, 2
	binary	hex.	dec.		
> 21	'0111.1111.1111.11XX'	0x7FFC	32764	0x42	on
> 20	'0111.1111.1111.11XX'	0x7FFC	32764	0x00	off
20,00	'0111.1111.1111.11XX'	0x7FFC	32764	0x00	off
17,50	'0111.0000.0000.00XX'	0x7000	28672	0x00	off
15,00	'0110.0000.0000.00XX'	0x6000	24576	0x00	off
12,50	'0101.0000.0000.00XX'	0x5000	20480	0x00	off
10,00	'0100.0000.0000.00XX'	0x4000	16384	0x00	off
7,50	'0011.0000.0000.00XX'	0x3000	12288	0x00	off
5,00	'0010.0000.0000.00XX'	0x2000	8192	0x00	off
2,50	'0001.0000.0000.00XX'	0x1000	4096	0x00	off
0,00	'0000.0000.0000.00XX'	0x0000	0	0x00	off
< 0	'0000.0000.0000.00XX'	0x0000	0	0x00	off
< -1	'0000.0000.0000.00XX'	0x0000	0	0x41	on

4.6 PIO-501 [2 DO DC 24 V 0.5 A, high-side switching]

2-Channel Digital Output Module DC 24 V 0.5 A,
short-circuit-protected, high-side switching

4.6.1 View

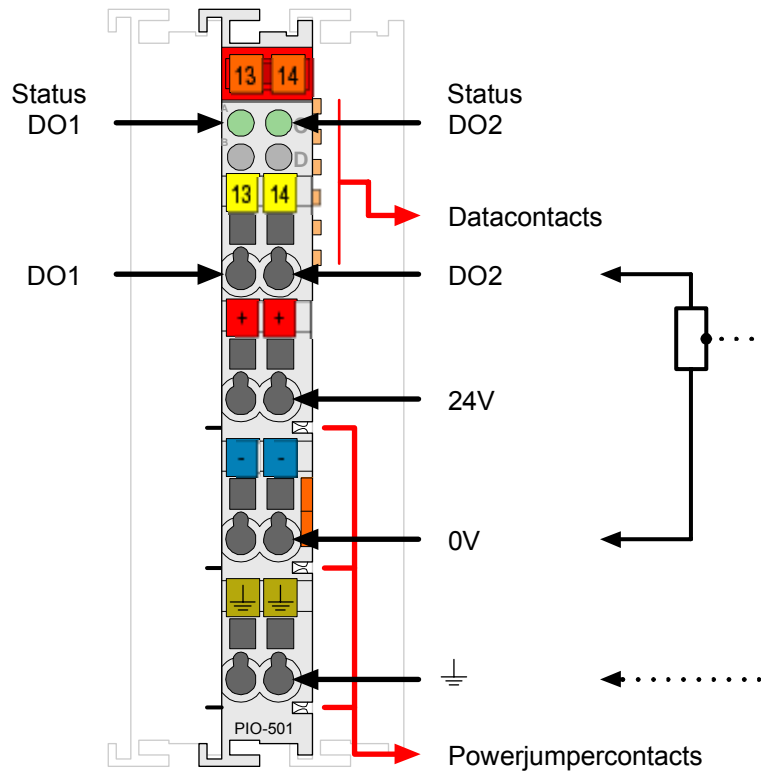

Fig. 4.6.1-1: 2-Channel Digital Output Module PIO-501

4.6.2 Description

The connected load is switched via the digital output from the control system. The module has two output channels. Two actuators with ground (earth) wire may be directly connected to signal output DO 1, 0V and PE (earth potential) or signal output DO 2, 0V and PE.



Note

For the connection of inductive loads a protected circuit, e. g. a recovery diode, has to be switched parallel to this load.

The output channels are electrically short-circuit-protected and high-side switching. Which means that the status of the output channels is "high" if the output channels switch to the 24 V supply voltage for the field side.

The status of the two output channels is indicated via green status LEDs.

An optocoupler is used for electrical isolation between the bus and the field side.

Any configuration of the output modules is possible when designing the fieldbus node. Grouping of module types is not necessary.

The field side supply voltage of 24 V for the output module is derived from adjacent I/O modules or from a supply module. The supply voltage for the field side is made automatically through the individual I/O modules by means of power jumper contacts.

The digital output module can be used with all couplers/controllers of the PARKER-I/O-SYSTEM PIO.

4.6.3 Display Elements

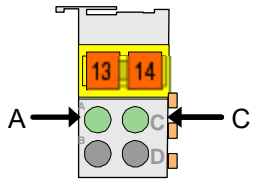

Fig. 4.6.3-1: Display Elements

LED	Channel	Designation	State	Function
A green	1	Status DO 1	off	Output DO 1: not active
			on	Output DO 1: active
C green	2	Status DO 2	off	Output DO 2: not active
			on	Output DO 2: active

4.6.4 Schematic Diagram

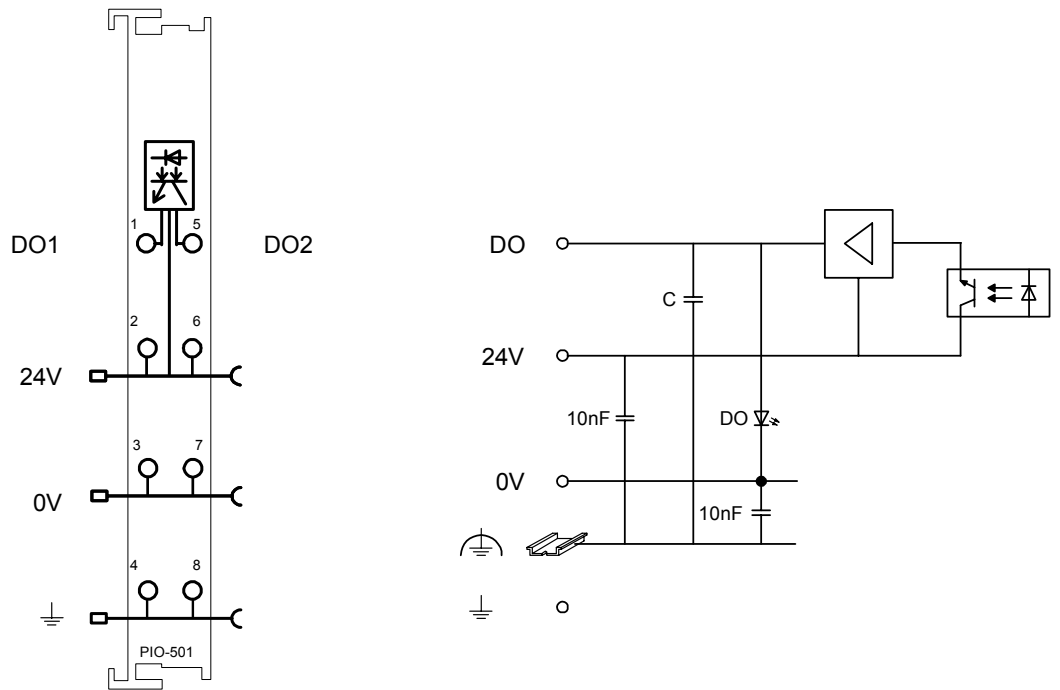

Fig. 4.6.4-1: 2-Channel Digital Output Module PIO-501

4.6.5 Technical Data

Module Specific Data	
Number of outputs	2
Current consumption (internal) _{max.}	3.5 mA
Voltage via power jumper contacts	DC 24 V (-15 % / +20%)
Type of load	resistive, inductive, lamps
Switching rate _{max.}	5 kHz
Reverse voltage protection	no
Output current	0.5 A
Absorbable energy $W_{max.}$ (unique switching off)	0.5 J $L_{max.} = 2 W_{max.} / I^2$
Isolation	500 V (system/field)
Current consumption _{typ.} (field side)	15 mA (per module) + load
Internal bit width	2 Bit out
Weight	ca. 50 g
Approvals	
UL	E198563, UL508
KEMA	01ATEX1024 X II 3 G EEx nA II T4
GL (Germanischer Lloyd)	40 197-01 HH Cat. A, B, C, D (EMC1)
LR (Lloyd's Register)	02/20026 Env. 1, 2, 3, 4
DNV (Det Norske Veritas)	A-8471 Cl. B
RINA (Registro Italiano Navale)	MAC30402CS1
ABS (American Bureau of Shipping)	03-HG374860-PDA
Conformity marking	CE

4.6.6 Process Image

Output bit	B1	B0
Meaning	controls DO 2 Channel 2	controls DO 1 Channel 1

4.7 PIO-504 [4 DO DC 24 V 0.5 A, high-side switching]

4-Channel Digital Output Module DC 24 V 0.5 A,
short-circuit-protected, high-side switching

4.7.1 View

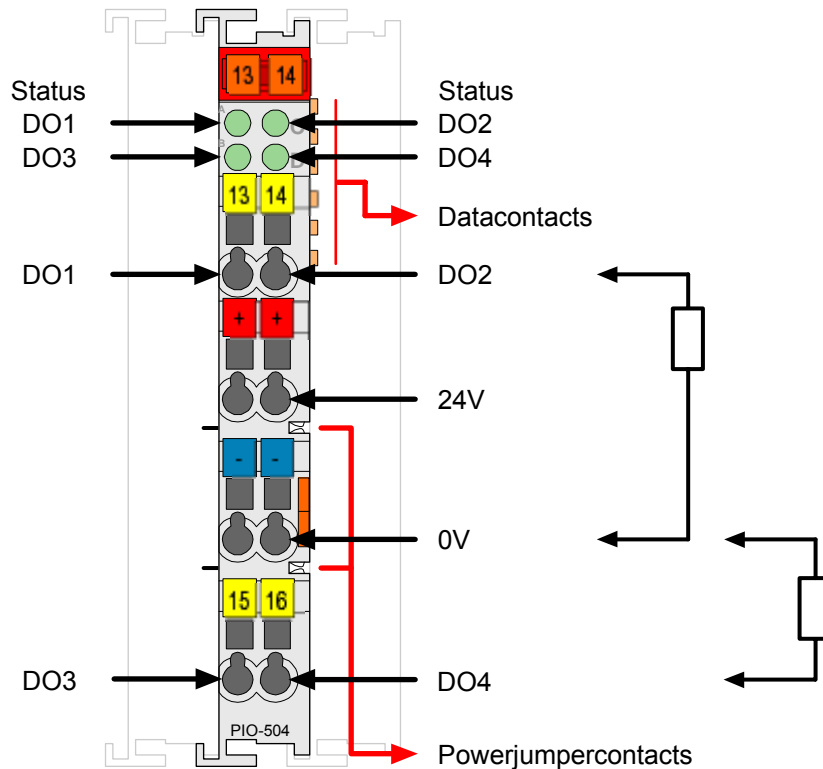

Fig. 4.7.1-1: 4-Channel Digital Output Module PIO-504

4.7.2 Description

The connected load is switched via the digital output from the control system. The module has four output channels. Two actuators may be directly connected to the module.

As an example, two 2-conductor actuators may be directly connected using connection 0 V and signal output DO 1 or 0 V and signal output DO 2.



Note

For the connection of inductive loads a protected circuit, e. g. a recovery diode, has to be switched parallel to this load.

The output channels are electrically short-circuit-protected and high-side switching. Which means that the status of the output channels is "high" if the output channels switch to the 24 V supply voltage for the field side.

The supply voltage for the field side is derived from an adjacent supply module by means of power jumper contacts.

The status of the four output channels is indicated via green status LEDs.

An optocoupler is used for electrical isolation between the bus and the field side.

Any configuration of the output modules is possible when designing the fieldbus node. Grouping of module types is not necessary.

The field side supply voltage of 24 V for the output module is derived from adjacent I/O modules or from a supply module. The supply voltage for the field side is made automatically through the individual I/O modules by means of power jumper contacts. The digital output module can be used with all couplers/controllers of the PARKER-I/O-SYSTEM PIO.

4.7.3 Display Elements

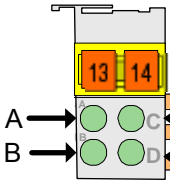

LED	Channel	Designation	State	Function
A green	1	Status DO 1	off	Output DO 1: not active
			on	Output DO 1: active
C green	2	Status DO 2	off	Output DO 2: not active
			on	Output DO 2: active
B green	3	Status DO 3	off	Output DO 3: not active
			on	Output DO 3: active
D green	4	Status DO 4	off	Output DO 4: not active
			on	Output DO 4: active

Fig. 4.7.3-1:
Display Elements

4.7.4 Schematic Diagram

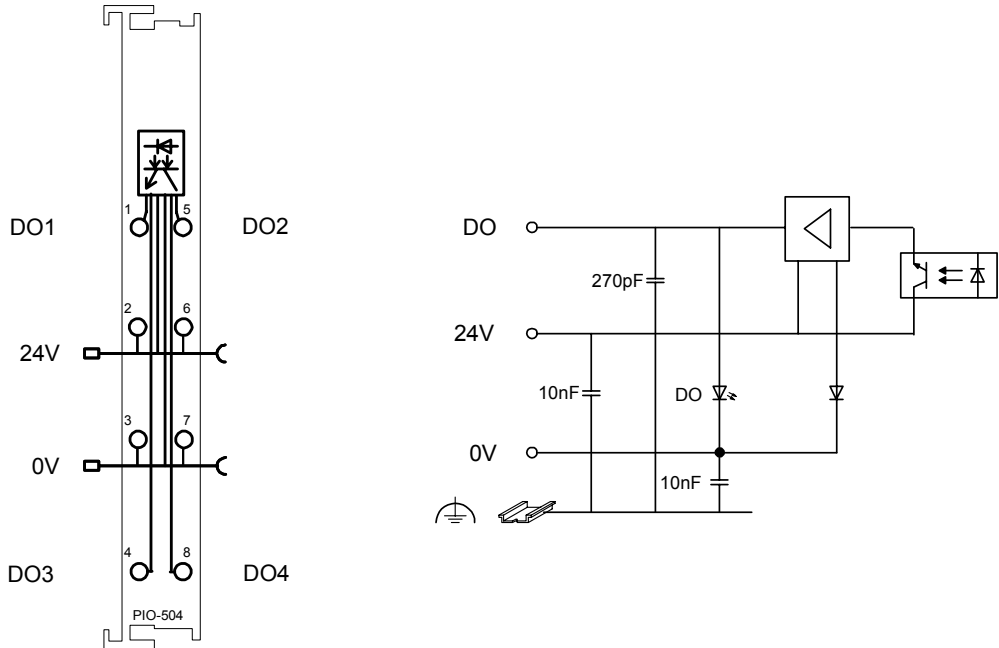

Fig. 4.7.4-1: 4-Channel Digital Output Module PIO-504

4.7.5 Technical Data

Module Specific Data	
Number of outputs	4
Current consumption (internal) _{max.}	7 mA
Voltage via power jumper contacts	DC 24 V (-15 % / + 20 %)
Type of load	resistive, inductive, lamps
Switching rate _{max.}	1 kHz
Reverse voltage protection	no
Output current	0.5 A short-circuit-protected
Absorbable energy $W_{max.}$ (unique switching off)	0.3 J $L_{max.} = 2 W_{max.} / I^2$
Isolation	500 V (system/field)
Current consumption _{typ.} (field side)	30 mA (per module) + load
Internal bit width	4 Bit out
Weight	ca. 50 g
Approvals	
UL	E198563, UL508
KEMA	01ATEX1024 X II 3 G EEx nA II T4
GL (Germanischer Lloyd)	40 197-01 HH Cat. A, B, C, D (EMC1)
LR (Lloyd's Register)	02/20026 Env. 1, 2, 3, 4
DNV (Det Norske Veritas)	A-8471 Cl. B
RINA (Registro Italiano Navale)	MAC30402CS1
ABS (American Bureau of Shipping)	03-HG374860-PDA
Conformity marking	CE

4.7.6 Process Image

Output bit	B3	B2	B1	B0
Meaning	controls DO 4 Channel 4	controls DO 3 Channel 3	controls DO 2 Channel 2	controls DO 1 Channel 1

4.8 PIO-530 [8 DO DC 24 V 0.5 A, high-side switching]

8-Channel Digital Output Module DC 24 V 0.5 A,
short-circuit-protected, high-side switching

4.8.1 View

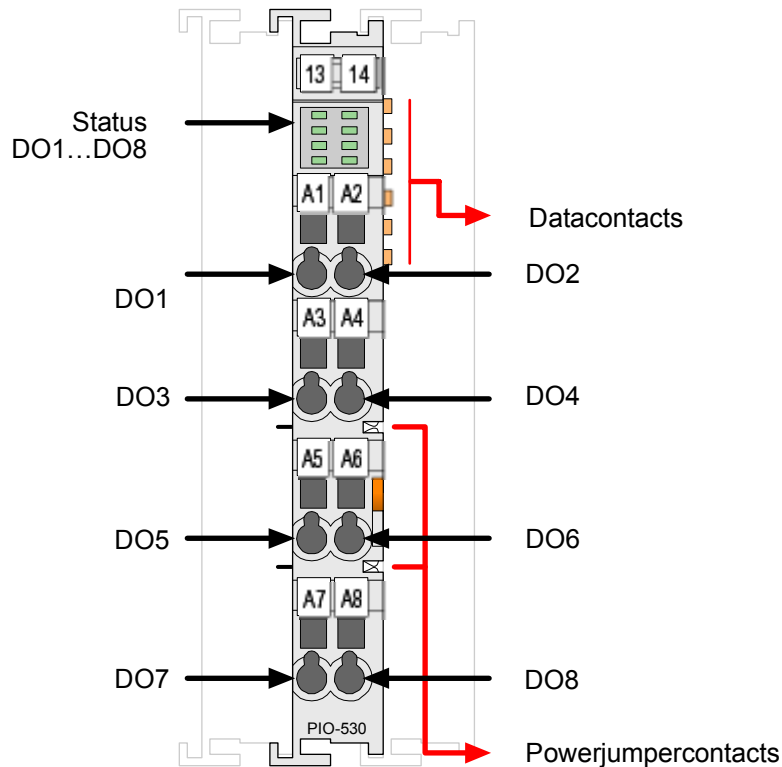

Fig. 4.8.1-1: 8-Channel Digital Output Module PIO-530

4.8.2 Description

The connected load is switched via the digital output from the control system. The module has eight output channels. Eight actuators may be directly connected using the connections signal output DO 1 to DO 8.



Note

For the connection of inductive loads a protected circuit, e. g. a recovery diode, has to be switched parallel to this load.

The output channels are high-side switching. This means that the status of the output channels is "high" when the 24 V field side supply voltage is internally connected to the output channels.

This voltage is fed in via the power jumper contacts of an adjacent supply module. The status of the eight short-circuit-protected output channels is indicated via green status LEDs.

An optocoupler is used for electrical isolation between the bus and the field side.

Any configuration of the output modules is possible when designing the fieldbus node. Grouping of module types is not necessary.

The field side supply voltage of 24 V for the output module is derived from adjacent I/O modules or from a supply module. The supply voltage for the field side is made automatically through the individual I/O modules by means of power jumper contacts. The digital output module can be used with all couplers/controllers of the PARKER-I/O-SYSTEM PIO.

4.8.3 Display Elements

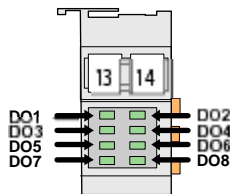

Fig. 4.8.3-1: Display Elements

LED	Channel	Designation	State	Function
green	1	Status DO 1	off	Output DO 1: not active
			on	Output DO 1: active
green	2	Status DO 2	off	Output DO 2: not active
			on	Output DO 2: active
green	3	Status DO 3	off	Output DO 3: not active
			on	Output DO 3: active
green	4	Status DO 4	off	Output DO 4: not active
			on	Output DO 4: active
green	5	Status DO 5	off	Output DO 5: not active
			on	Output DO 5: active
green	6	Status DO 6	off	Output DO 6: not active
			on	Output DO 6: active
green	7	Status DO 7	off	Output DO 7: not active
			on	Output DO 7: active
green	8	Status DO 8	off	Output DO 8: not active
			on	Output DO 8: active

4.8.4 Schematic Diagram

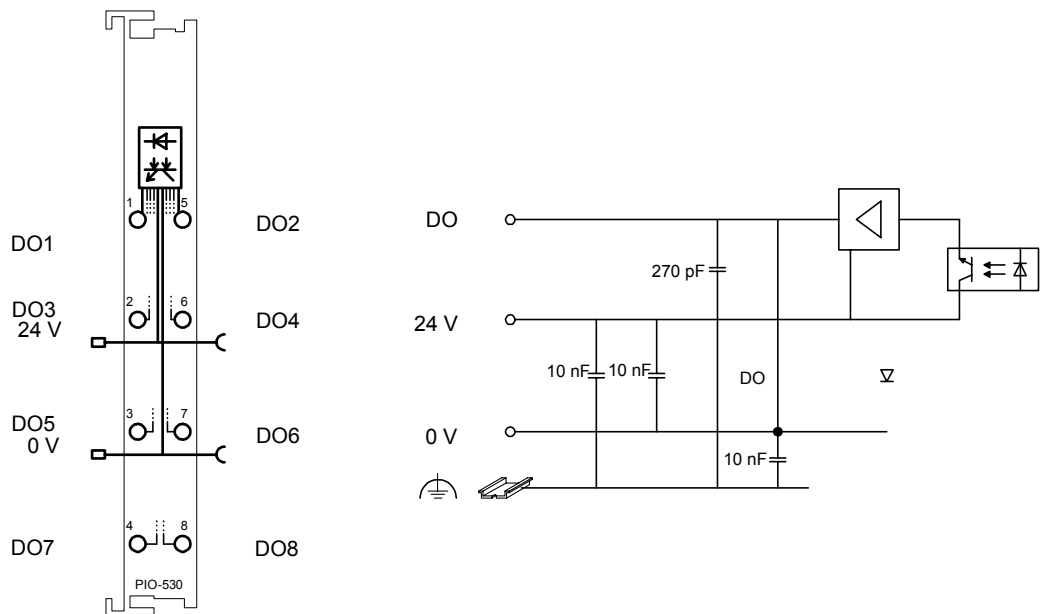

Fig. 4.8.4-1: 8-Channel Digital Output Module PIO-530

4.8.5 Technical Data

Module Specific Data	
Number of outputs	8
Current consumption (internal)	25 mA
Voltage via power jumper contacts	DC 24 V (-15 % / +20%)
Type of load	resistive, inductive, lamps
Switching rate _{max.}	2 kHz
Reverse voltage protection	yes
Output current	0.5 A short-circuit-protected
Absorbable energy $W_{max.}$ (unique switching off)	0.9 J $L_{max.} = 2 W_{max.} / I^2$
Isolation	500 V (system/field)
Current consumption _{typ.} (field side)	15 mA (per module) + load
Internal bit width	8 Bit out
Weight	ca. 50 g
Approvals	
UL	E198563, UL508
DEMKO	02 ATEX 132273 X II 3 GD EEx nA II T4
Conformity marking	CE

4.8.6 Process Image

Output bit	B7	B6	B5	B4	B3	B2	B1	B0
Meaning	controls DO 8 – Channel 8	controls DO 7 – Channel 7	controls DO 6 – Channel 6	controls DO 5 – Channel 5	controls DO 4 – Channel 4	controls DO 3 – Channel 3	controls DO 2 – Channel 2	controls DO 1 – Channel 1

4.9 PIO-550 [2 AO DC 0-10 V]

2-Channel Analog Output Module 0-10 V

4.9.1 View

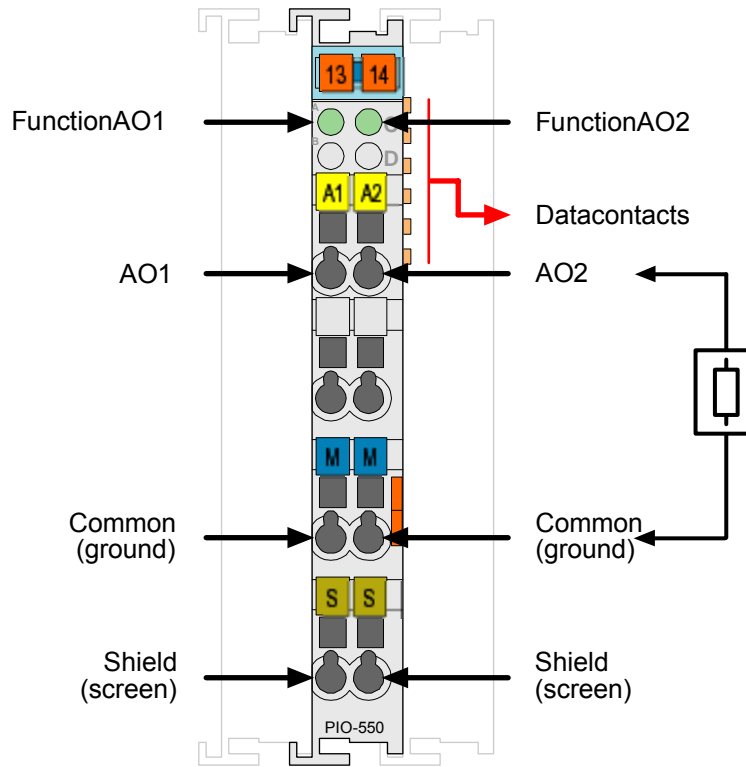

Fig. 4.9.1-1: 2-Channel Analog Output Module PIO-550

4.9.2 Description

The analog output module PIO-550 create a standardized signal of 0-10 V.

The module has two short circuit protected output channels and enables the direct wiring of two 2-conductor actuators to AO 1 and ground or AO 2 and ground. The signals are transmitted via AO 1 or AO 2.

The channels have a common ground and a shield (screen) (S). The shield (screen) is directly connected to the DIN rail. A capacitive connection is made automatically when snapped onto the DIN rail.

The input signal is electrically isolated and will be transmitted with a resolution of 12 bits.

The operational readiness and the trouble-free internal data bus communication of the channels are indicated via a function LED.

Any configuration of the input modules is possible when designing the fieldbus node. Grouping of module types is not necessary.

The voltage supply is done via the internal system voltage.



Attention

This module is not provided with integrated power jumper contacts. For field supply to downstream I/O modules, a supply module will be needed.

The analog output module can be used with all couplers/controllers of the PARKER-I/O-SYSTEM PIO.

4.9.3 Display Elements

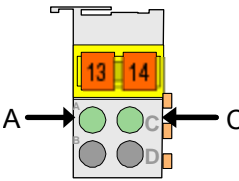

Fig. 4.9.3-1: Display Elements

LED	Channel	Designation	State	Function
A green	1	Function AO 1	off	No operational readiness or the internal data bus communication is interrupted
			on	Operational readiness and trouble-free operational readiness
C green	2	Function AO 2	off	No operational readiness or the internal data bus communication is interrupted
			on	Operational readiness and trouble-free operational readiness

4.9.4 Schematic Diagram

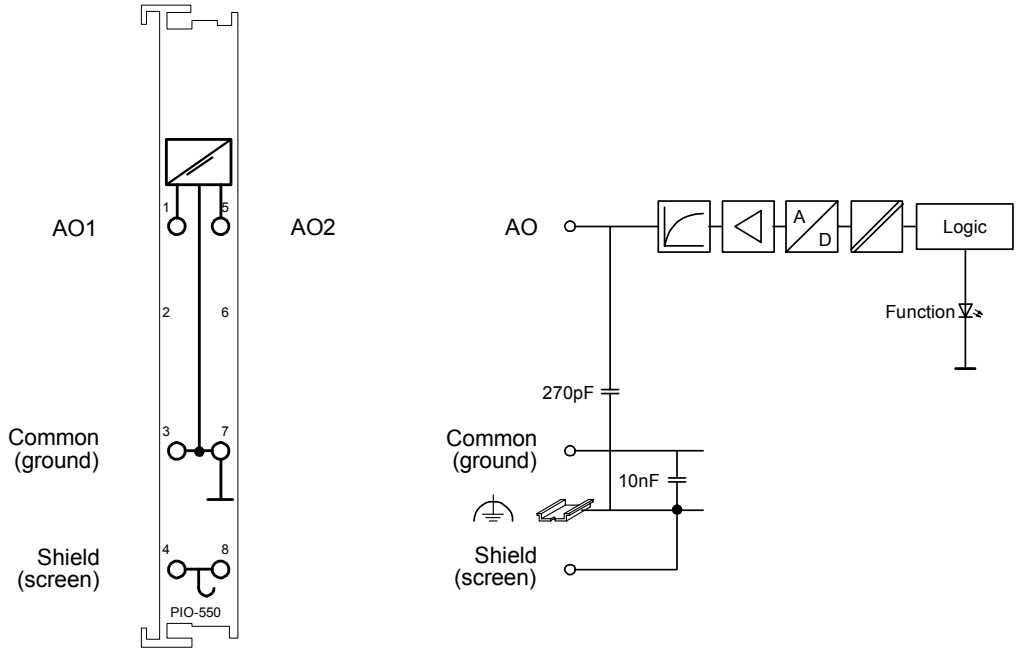

Fig. 4.9.4-1: 2-Channel Analog Output Module PIO-550

4.9.5 Technical Data

Module Specific Data	
Number of outputs	2
Voltage supply	via system voltage DC/DC
Current consumption _{typ.} (internal)	65 mA
Signal voltage	0 ... 10 V
Load impedance	> 5 k Ω
Resolution	12 Bit
Conversion time _{typ.}	2 ms
Measuring error _{25°C}	< \pm 0,1 % of the full scale value
Temperature coefficient	< \pm 0,01 %/°K of the full scale value
Isolation	500 V _{eff} (system/supply)
Bit width	2 x 16 bits data 2 x 8 bits control/status(option)
Weight	ca. 55 g
Approvals	
UL	E198563, UL508
KEMA	01ATEX1024 X II3G EEx nA II T4
GL (Germanischer Lloyd)	40 197-01 HH Cat. A,B,C,D (EMC1)
LR (Lloyd's Register)	02/20026 Env. 1, 2, 3, 4
DNV (Det Norske Veritas)	A-8471 Cl. B
RINA (Registro Italiano Navale)	MAC30402CS1
ABS (American Bureau of Shipping)	03-HG374860-PDA
Conformity marking	CE

4.9.6 Process Image

The analog output module PIO-550 transmit 16-bit data and 8 status bits per channel. The digitalized output value is transmitted in a data word (16 bits) as output byte 0 (low) and output byte 1 (high) into the process image of the coupler / controller. This value is represented with a 12 bit resolution on bit B3 ... B14. The three least significant bits (B0 ... B2) are not parsed. Some fieldbus systems can process status information by means of a status byte. As the returned status byte of this output module is always zero, it will not be parsed.

4.9.7 Standard Format

For the standard module PIO-550, the numerical values ranging from 0x0000 to 0x7FFF are scaled on the output voltage ranging from 0 V to 10 V.

Process values of module PIO-550				
Output voltage 0 - 10 V	numerical value			status- byte hex.
	binary ouptput value	hex.	dec.	
0	0000 0000 0000 0000	00 00	0	00
1,25	0001 0000 0000 0000	10 00	4096	00
2,5	0010 0000 0000 0000	20 00	8192	00
3,75	0011 0000 0000 0000	30 00	12288	00
5	0100 0000 0000 0000	40 00	16384	00
6,25	0101 0000 0000 0000	50 00	20480	00
7,5	0110 0000 0000 0000	60 00	24576	00
8,75	0111 0000 0000 0000	70 00	28672	00
10	0111 1111 1111 1111	7F FF	32764	00

4.10 PIO-552 [2 AO 0-20 mA]

2-Channel Analog Output Module 0-20 mA.

4.10.1 View

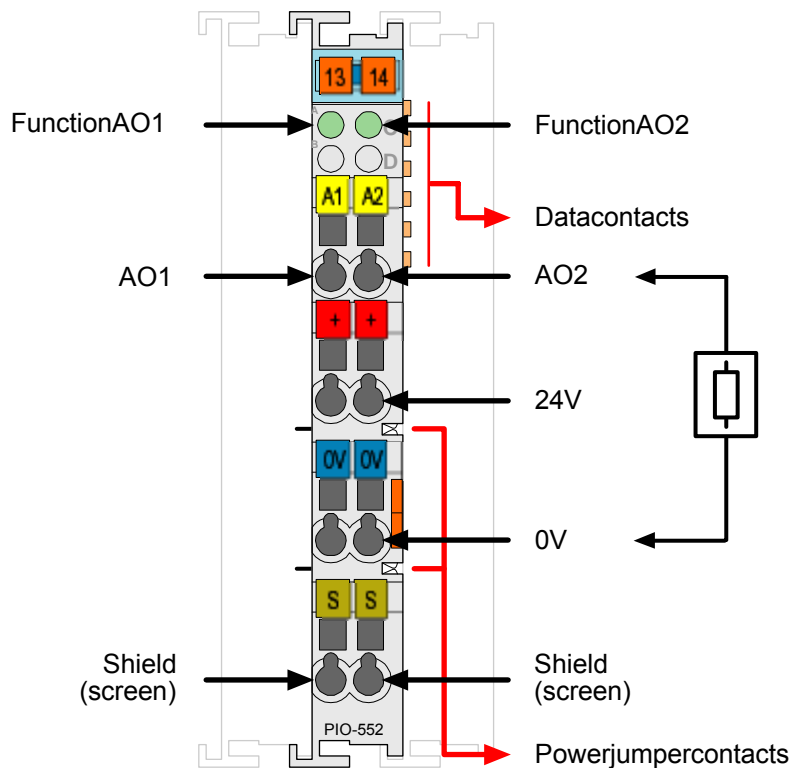

Fig. 4.10.1-1: 2-Channel Analog Output Module PIO-552

4.10.2 Description

The analog output module PIO-552 create a standardized signal of 0-20 mA.

The module has two output channels and enables, for example, the direct wiring of two 2-conductor actuators to the connections AO 1 and 0V or AO 2 and 0V. The signals are transmitted via AO 1 or AO 2.

The channels have a common ground and a shield (screen) (S). The shield (screen) is directly connected to the DIN rail. A capacitive connection is made automatically when snapped onto the DIN rail.

The input signal is electrically isolated and will be transmitted with a resolution of 12 bits.

The operational readiness and the trouble-free internal data bus communication of the channels are indicated via a green function LED.

Any configuration of the input modules is possible when designing the fieldbus node. Grouping of module types is not necessary.

The voltage supply is done via the field supply.

The field side supply voltage of 24 V for the output module is derived from an adjacent I/O module or from a supply module. A capacitive connection of the supply potential to the adjacent I/O modules is made automatically via the internal power contacts when snapping the output modules.



Note

Use an appropriate supply module (e.g. PIO-602) if an electrically isolated voltage supply is required!

The analog output module can be used with all couplers/controllers of the PARKER-I/O-SYSTEM PIO.

4.10.3 Display Elements

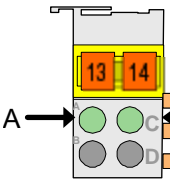

Fig. 4.10.3-1: Display Elements

LED	Channel	Designation	State	Function
A green	1	Function AO 1	off	No operational readiness or the internal data bus communication is interrupted
			on	Operational readiness and trouble-free internal data bus communication
C green	2	Function AO 2	off	No operational readiness or the internal data bus communication is interrupted
			on	Operational readiness and trouble-free internal data bus communication

4.10.4 Schematic Diagram

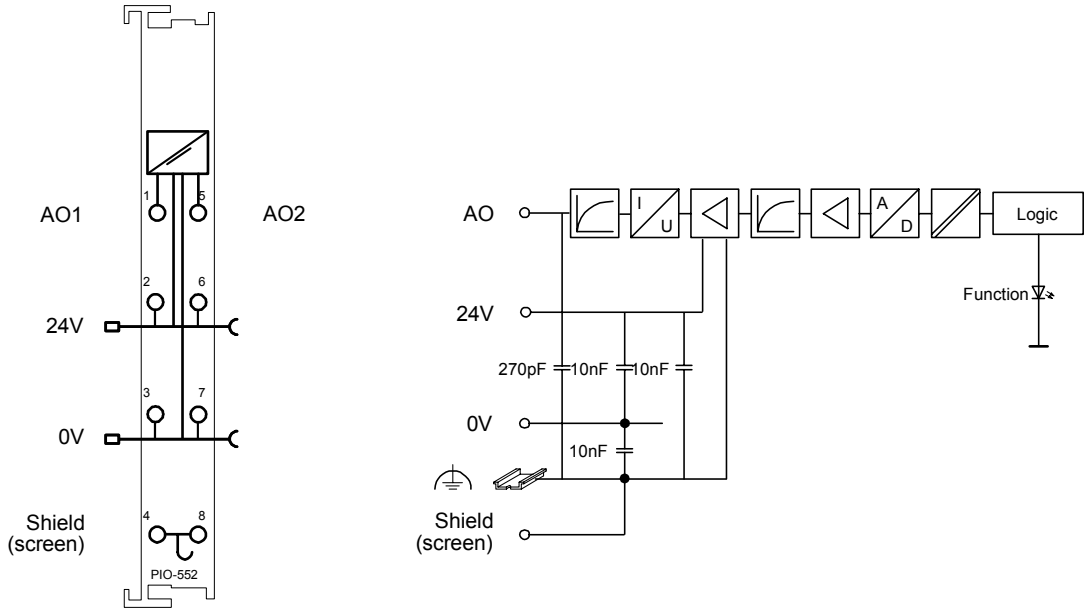

Fig. 4.10.4-1: 2-Channel Analog Output Module PIO-552

4.10.5 Technical Data

Module Specific Data	
Number of outputs	2
Voltage supply	via system voltage DC 24 V (-15% ... +20%)
Current consumption _{typ.} (internal)	60 mA
Signal voltage	0... 20 mA
Load impedance	< 500 Ω
Linearity	± 2 LSB
Resolution	12 Bit
Conversion time _{typ.}	2 ms
Measuring error _{25°C}	<± 0,1 % of the full scale value
Temperature coefficient	<± 0,01 %/°K of the full scale value
Isolation	500 V _{eff} (system/supply)
Bit width	2 x 16 bits data 2 x 8 bits control/status(option)
Weight	ca. 55 g
Approvals	
UL	E198563, UL508
KEMA	01ATEX1024 X II 3 G EEx nA II T4
GL (Germanischer Lloyd)	40 197-01 HH Cat. A, B, C, D (EMC1)
LR (Lloyd's Register)	02/20026 Env. 1, 2, 3, 4
DNV (Det Norske Veritas)	A-8471 Cl. B
RINA (Registro Italiano Navale)	MAC30402CS1
ABS (American Bureau of Shipping)	03-HG374860-PDA
Conformity marking	CE

4.10.6 Process Image

The analog output module PIO-552 transmit 16-bit data and 8 status bits per channel. The digitalized output value is transmitted in a data word (16 bits) as output byte 0 (low) and output byte 1 (high) via the process image of the coupler / controller. This value is represented with a 12 bit resolution on bit B3 ... B14. The three least significant bits (B0 ... B2) are not parsed. Some fieldbus systems can process the status information using by means of a status byte. As the returned status byte of this output module is always zero, it will not be parsed.

4.10.7 Standard Format

For the standard module PIO-552, the numerical values ranging from 0x0000 to 0x7FFF are scaled on the output current ranging from 0 mA to 20 mA.

Process values of module PIO-552				
Output current 0 - 20 mA	numerical value			status- byte hex.
	binary output value	hex.	dec.	
0	0000 0000 0000 0000	00 00	0	00
2,5	0001 0000 0000 0000	10 00	4096	00
5	0010 0000 0000 0000	20 00	8192	00
7,5	0011 0000 0000 0000	30 00	12288	00
10	0100 0000 0000 0000	40 00	16384	00
12,5	0101 0000 0000 0000	50 00	20480	00
15	0110 0000 0000 0000	60 00	24576	00
17,5	0111 0000 0000 0000	70 00	28672	00
20	0111 1111 1111 1111	7F FF	32764	00

4.11 PIO-600 [End Module]

End Module

4.11.1 View

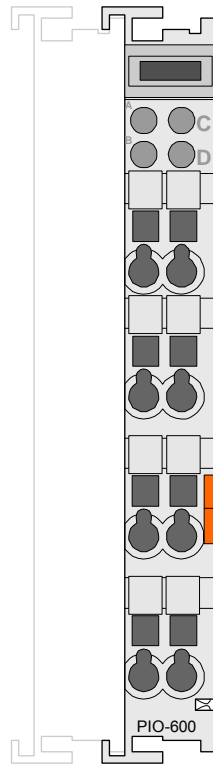

Fig. 4.11.1-1: End Module PIO-600

4.11.2 Description

After the fieldbus node is assembled with the correct buscoupler and selected I/O modules, the end module PIO-600 is snapped onto the assembly.

This module completes the internal data circuit and ensures correct data flow.

The end module is a necessary component to all PARKER-I/O-SYSTEM PIO fieldbus nodes.

4.11.3 Technical Data

Module Specific Data	
Weight	ca. 35 g
Approvals	
UL	E198563, UL508
KEMA	01ATEX1024 X II 3 G EEx nA II T4
GL (Germanischer Lloyd)	40 197-01 HH Cat. A, B, C, D (EMC1)
LR (Lloyd's Register)	02/20026 Env. 1, 2, 3, 4
DNV (Det Norske Veritas)	A-8471 Cl. B
RINA (Registro Italiano Navale)	MAC30402CS1
ABS (American Bureau of Shipping)	03-HG374860-PDA
Conformity marking	CE

4.12 PIO-602 [24 V DC Power Supply]

Supply Module DC 24 V, passive

4.12.1 View

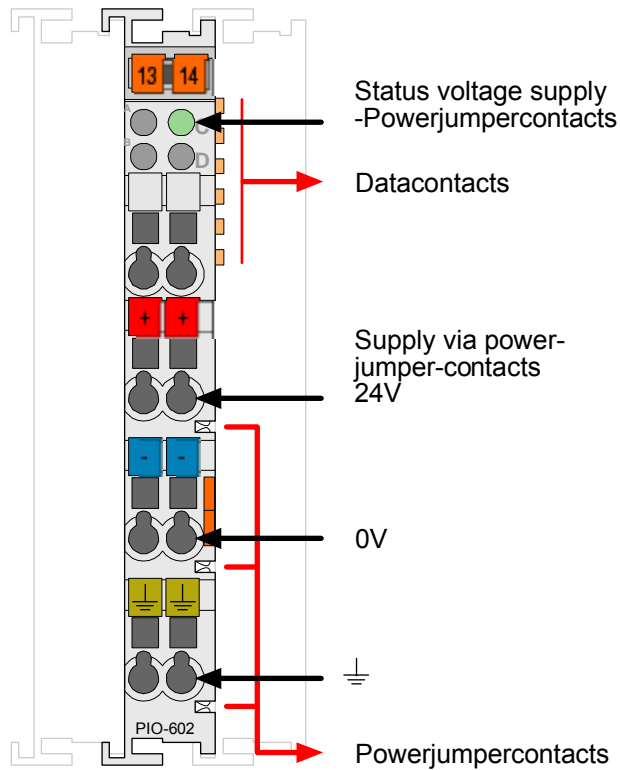

Fig. 4.12.1-1: Supply Module PIO-602

4.12.2 Description

The supply module PIO-602 provides an electrically isolated DC 24 V fieldside power to the adjacent I/O modules.

The module is fed in external via the 24 V, 0V and PE (earth potential) connections. A capacitive connection of the potentials to the adjacent I/O modules is made automatically via the internal power contacts when snapping the I/O modules together.



Note

Maximum current supply to all connected modules is 10 A. Should more current be needed, additional supply modules may be added in the assembly.



Note

Pay particular attention to the admissible voltage of each I/O module when using the supply modules.

The operating voltage of 24 V is indicated via a green status LED.

Any configuration of the output modules is possible when designing the fieldbus node. Grouping of module types is not necessary.

The supply module can be used with all couplers/controllers of the PARKER-I/O-SYSTEM PIO.

4.12.3 Display Elements

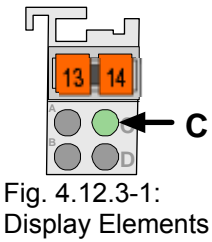

LED	Designation	State	Function
C green	Status voltage supply -Power jumper contacts	off	No DC 24 V voltage supply via power jumper contacts.
		on	DC 24 V voltage supply via power jumper contacts.

4.12.4 Schematic Diagram

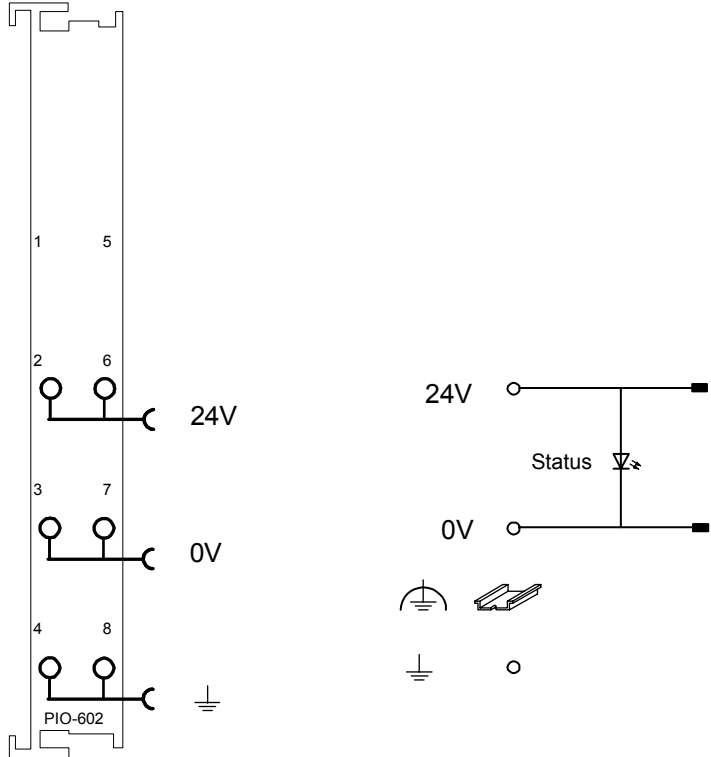

Fig. 4.12.4-1: Supply Module PIO-602

4.12.5 Technical Data

Module Specific Data	
Voltage via power jumper contacts _{max}	DC 24 V
Current via power jumper contacts _{max}	10 A
Weight	ca. 45 g
Approvals	
UL	E198563, UL508
KEMA	01ATEX1024 X II 3 G EEx nA II T4
GL (Germanischer Lloyd) ¹⁾	40 197-01 HH Cat. A, B, C, D
LR (Lloyd's Register) ¹⁾	02/20026 Env. 1, 2, 3, 4
DNV (Det Norske Veritas) ¹⁾	A-8471 Cl. B
RINA (Registro Italiano Navale) ¹⁾	MAC30402CS1
ABS (American Bureau of Shipping) ¹⁾	03-HG374860-PDA
Conformity marking	CE

¹⁾ Note information on "Voltage Supply"!

5 DeviceNet

5.1 Description

DeviceNet is a networking concept in the device level based on the serial bus system CAN (Controller Area Network). It is particularly distinguished by the problem-free addition and removal of devices, from simple light barriers up to complex motor controls during operation. DeviceNet is mainly used in industrial automation and for robot controls.

The Data Link Layer, i.e. the physical and data storage layer, is defined in the CAN specification. The telegram architecture is described. However, there is no information about the application layer.

This is where DeviceNet comes into play. It describes the defined meaning of the data transmitted in the application layer.

The Open DeviceNet Vendor Association (abridged: ODVA) is the user organisation for DeviceNet. In a specification, the ODVA DeviceNet is defined as a uniform application layer and it lays down technical and functional features for device networking.

A maximum of 64 fieldbus nodes can be operated in one DeviceNet network. The extension of the network depends on the selected baud rate (125 kBaud, 250 kBaud or 500 kBaud).

In contrast to other fieldbus systems, CAN does not address the modules connected to the bus but identifies the messages. Whenever the bus is free, subscribers are allowed to send messages. Each bus subscriber decides on its own when it wants to send data or instigate other bus subscribers to send data. This permits a communication without a bus master assembly group.

Bus conflicts are solved in that the messages are assigned a certain priority. This priority is defined by the CAN identifier, called Connection ID in DeviceNet. The following rule applies: the smaller the identifier, the higher the priority.

A general distinction between high priority process messages (I/O Messages) and low priority management messages (Explicit Messages) is done before. Messages having a data length of more than 8 bytes can be fragmented.

The communication with DeviceNet occurs always connection-referenced (connection based). All data and functions of a device are described by means of an object model. Therefore, for a message exchange directly after switching on a device, the connections to the desired subscriber have to be established first and communication objects be created or allocated. Message distribution is according to the broadcast system, data exchange according to the producer consumer model.

A transmitting DeviceNet node produces data that is either consumed via a point-to-point connection (1 to 1) by one receiving nodes, or via a multicast connection (1 to n) by several receiving node.



Further information

The Open DeviceNet Vendor Association (ODVA) provides further documents in the Internet under:

<http://www.odva.org>

5.2 Network Architecture

5.2.1 Transmission Media

Type of Cable

A bus medium forms the basis for the physical realisation of a network using DeviceNet.

According to the line specification, a double 2-conductor twisted pair cable (twisted pair, screened cable) is recommended to be used as a medium.

It consists of two screened twisted pair cables with a wire in the middle of the cable. Further screening extended at the outside.

The blue and the white twisted pair cable is used for signal transmission, the black and red one for the supply voltage.

Cable Types

The DeviceNet bus is configured using a remote bus cable as the trunk line and several drop lines.

For this purpose, the DeviceNet specification distinguishes between 2 cable types:

- Thick Cable**
 For the trunk line of maximal 8 A or for networks extending over more than 100 m. The trunk line topology is linear, i.e. the remote bus cables are not further branched. On each end of the remote bus cable, terminating resistors are required.
- Thin Cable**
 For drop lines with maximum 3 A or for networks extending less than 100 m. One or more nodes can be connected to the drop lines, in other words, branching is permitted here. The length of the individual drop lines is measured from the branching point of the node and can be up to 6 m. The entire length of the drop line depends on the Baud rate.



Note

If possible, route the data line separately from all high current carrying cables.



Further information

For a detailed specification regarding the cable types, please refer to the INTERNET under: <http://www.odva.org>.

Maximum Bus Length

In the following table, the permitted cable length is represented in dependence of the Baud rate. Here a differentiation is made between the maximum length for a transmission using a thick and a thin cable.

Baud rate	Bus length			Tap line length	
	Thick + Thin Cable	only Thick Cable	only Thin Cable	maximal	cumulated
500 kbit/s	$L_{\text{Thick}} + L_{\text{Thin}} \leq 100 \text{ m (328 ft)}$	100 m (328 ft)	100 m (328 ft)	6 m (19,6 ft)	39 m (127,9 ft)
250 kbit/s	$L_{\text{Thick}} + 2,5 \cdot L_{\text{Thin}} \leq 250 \text{ m (820,2 ft)}$	250 m (820,2 ft)	100 m (328 ft)	6 m (19,6 ft)	78 m (255,9 ft)
125 kbit/s	$L_{\text{Thick}} + 5 \cdot L_{\text{Thin}} \leq 500 \text{ m (1640,4 ft)}$	500 m (1640,4 ft)	100 m (328 ft)	6 m (19,6 ft)	156 m (511,8 ft)

Tab. 5-1: Maximum bus length dependent on the set Baud rate

When specifying the maximum cable lengths, it is made sure that communication is possible between two nodes located at maximum distance to each other (worst case).

5.2.2 Cabling

The connection of a fieldbus node to the DeviceNet bus cable is made by the supplied 5-pole plug (Multi Connector 231).

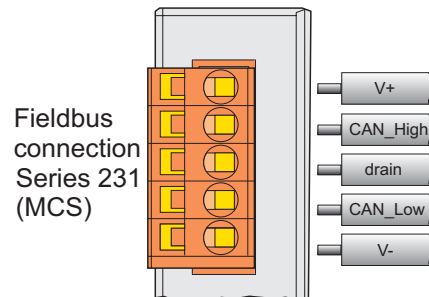

Fig. 5-1: Plug assignment for the fieldbus connection

For wiring using a screened cable, the plug is assigned the connections V+, V- for the voltage supply and with CAN_High, CAN_Low for data transmission.

The 24 V field bus supply is fed by an external fieldbus network power supply.

CAN_High and CAN_Low are two physically different bus levels.

The cable screen is connected to the drain connection.

This is terminated with a 1 M Ω resistor to the DIN rail via the clip on the bottom of the coupler. The DIN rail must then be directly connected to the Grounding Stud that must be connected to Earth Ground. We strongly recommend a central Earth Ground for the entire DeviceNet Bus conductor screening on PE terminal can only be made externally.

Each DeviceNet node forms the differential voltage U_{Diff} with:

$U_{Diff} = U_{CAN_High} - U_{CAN_Low}$. using the bus levels CAN_High and CAN_Low.

Differential signal transmission offers the advantage of an insensitivity compared to common mode malfunctions and ground offset between the nodes.



Note

At its conductor ends, the bus cable must always be connected with a matching resistor of 120 Ohm to avoid reflections and, as a result, transmission problems. This is also required for very short conductor lengths.

The CAN bus is a 2-wire bus and bus error management can detect a cable break or a short-circuit by the asymmetric operation.



Further information

The CiA provides documents regarding specifications, especially cable specifications on the Internet under:

<http://www.can-cia.de>

5.2.3 Network Topology

To build a simple DeviceNet network, you need a scanner (PC with a DeviceNet fieldbus PCB card), a connection cable and a DC 24 V power pack to ensure the power supply in addition to a DeviceNet fieldbus node.

The CANopen network is constructed as a line structure with matching resistors (120 Ohm).

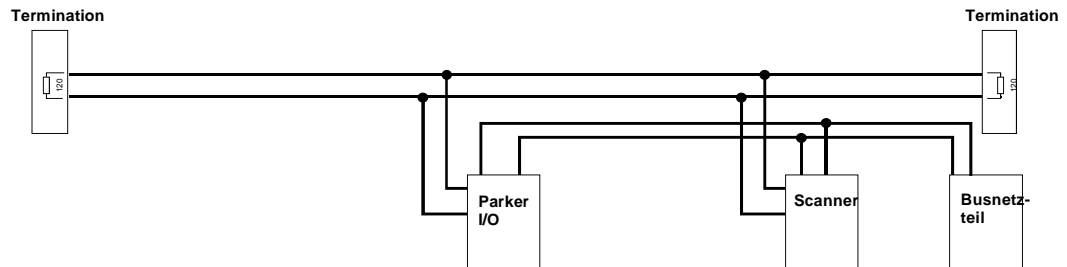

In systems accommodating more than two stations, all subscribers are wired in parallel. Node connection to the remote bus cable (trunk line) is made by means of drop lines. For this purpose, the bus cable has to be looped without interruption. A maximum length of 6 m for a drop line should not be exceeded.

The following is a topology example:

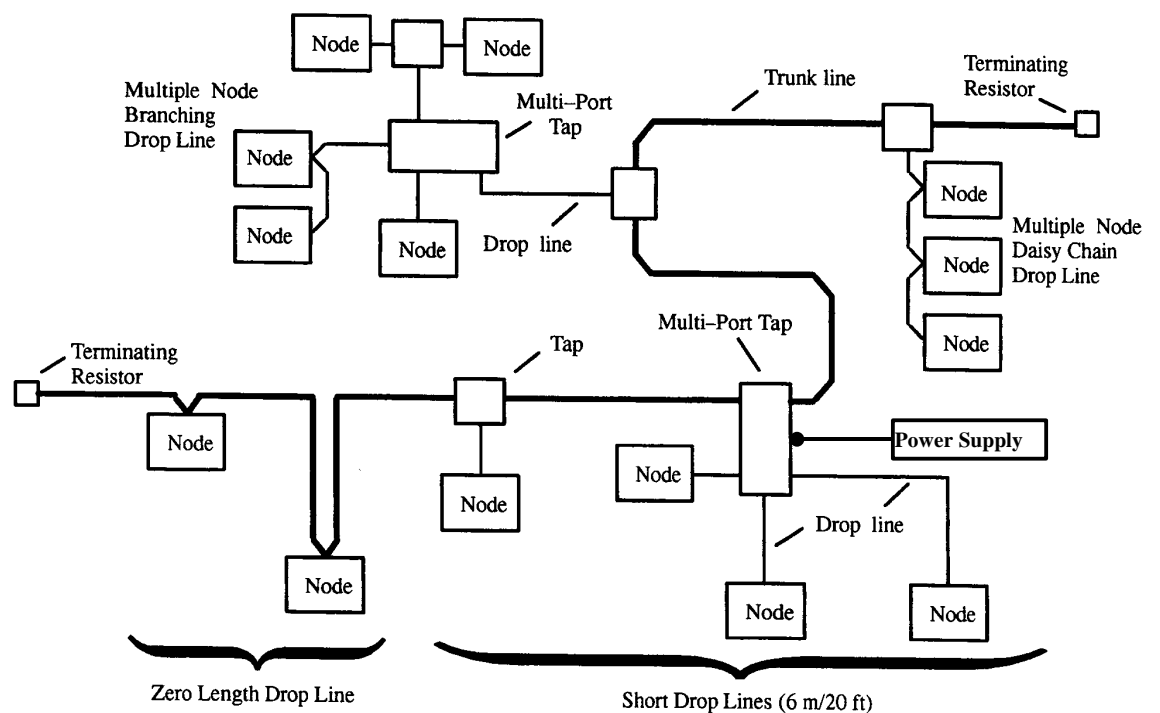

All subscribers in the network communicate at the same Baud rate. The bus structure permits the interference-free connection and disconnection of stations or a stepped start-up of the I/O-system.

Future extensions have no influence on the stations already in operation. Should a subscriber fail or be added to the network as a new one, it is automatically detected by the I/O-system.

5.2.4 Network Grounding

The devices can either be power supplied via the DeviceNet bus or have their own power supply.

Prerequisite being, however, that the network is only grounded at one point. Preferably, grounding is in the network center (V and screen drain with round media) to optimise the capacity and minimize interference.

Not permitted are ground loops via devices that are not disconnected from the power supply. The device must either be insulated or, if this is not possible, the power must be correspondingly disconnected in the device.

5.2.5 Interface Modules

In a network, all DeviceNet fieldbus nodes are delivered to operate as slaves. The master operation is taken over by a central control system, such as PLC, NC or RC.

5.3 Network Communication

5.3.1 Objects, Classes, Instances and Attributes

Protocol processing of DeviceNet is object oriented. Each node in the network is represented as a collection of objects. In the following, several terms connected with them are defined:

- **Object:**
Object is an abstract representation of individual components within a device belonging to each other. It is defined by its data or attributes, its external functions or services available, and by its defined behaviour.
- **Class:**
A class includes objects of a product belonging together, it is organised in instances, e.g. Identity Class, DeviceNet Class.
- **Instance:**
An instance is composed of various variables (attributes). Differing instances of a class have the same services, the same behaviour and the same variables (attributes). However, they can have different variable values, e.g. different connection instances: Explicit Message, Poll I/O or Bit-Strobe connection instance.
- **Attributes:**
The attributes represent data provided by a device via DeviceNet. They contain the current values, e.g. a configuration of an input, such as, for instance Vendor ID, Device Type or Product Name.
- **Service:**
Services can be applied to classes and attributes. They perform defined actions, e.g. reading of variables (attributes) or resetting a class.
- **Behaviour:**
The behaviour defines how a device reacts as a consequence of external events, such as changed process data, or as a consequence of internal events, such as expiring timers.

5.4 Module Characteristics

The I/O module is defined by vendor ID and device type.

Vendor ID	0x04
DeviceType	0x0C (12), Communication Adapter

5.4.1 Communication Model

Message Groups

CAN messages are divided into several groups in order to achieve different priorities.

- message group 1 serves to exchange I/O data via I/O messages
- message group 2 is reserved for Master/Slave applications
- message group 3 serves to exchange configurations data via explicit messages
- message group 4 is reserved for system administration (i. e. Offline Connection Set)

The CAN Identifier (Connection ID) and with it the priority is built via different message groups and the MAC ID.

DeviceNet has 2 types of messages:

- I/O Messages and
- Explicite Messages

I/O Messaging

I/O messages are sent by a node and can be received by one or several other nodes. Only I/O data is transmitted and no protocol data is specified by this way.

Explicit Messaging

Explicit messages are sent directly from one node to another. They consist of a request and an answer. Therefore services can be requested directly from another node. The data field consists of the service identification and the destination address. The format of the explicit messages is defined. Via explicit messages devices can be configured or a dynamic built-up of message connections can be made.

5.4.2 I/O Messaging Connections

The transfer or exchange of process data between the scanner and the I/O device is made via a „Polled I/O Connection“, „Change of State/Cyclic“ or „Bit Strobe“.

Polled I/O Connection	Slaves are cyclically polled by the master.
Strobe Function	All slaves are polled by the master by means of a command.
Change of State	Messages are transmitted either cyclically by the master or the slave, or in the event of a state change.

5.5 Process Data and Diagnostic Status

The data is transmitted between master and slave in the form of objects, a differentiation being made between input and output objects. The object architecture is defined by assembly objects which serve to group attributes of differing application objects. I/O data of different objects can, for this reason, be grouped to form a data block and transmitted by a message connection.

5.5.1 Process Image

The process image is differentiated according to input and output process images. The assembly object makes a statically configured process image available in the instances 1 ... 9.

The desired process image can be selected by setting the Produced Connection Path and the Consumed Connection Path of the individual I/O connections (Poll, Bit Strobe, Change of State or Change of Value).

The architecture of the individual instances of the assembly object is described in the following.

Assembly Instances

Permanently pre-programmed (static) assemblies in the device permit an easy and rapid transmission of input and output images from the fieldbus coupler to the master. For this purpose, various assembly instances are provided in the fieldbus coupler:

Output 1 (I/O Assembly Instance 1):

The entire output data image is transmitted from the master to the coupler via the corresponding I/O message connection. In this case, the data length corresponds to the number of output data in bytes. Analog output data come before digital output data.

Output 2 (I/O Assembly Instance 2):

The digital output data image is transmitted from the master to the coupler via the corresponding I/O message connection. The data length is equivalent to the number of digital output data and is rounded up to full bytes.

Output 3 (I/O Assembly Instance 3):

The analog output data image is transmitted from the master to the coupler via the corresponding I/O message connection. The data length is equivalent to the number of analog output data in bytes.

Input 1 (I/O Assembly Instance 4):

The entire input data image and one status byte are transmitted to the master via the corresponding I/O message connection. The data length is equivalent to the number of input data in bytes and one status byte.

Input 2 (I/O Assembly Instance 5):

The digital input data image and one status byte are transmitted to the master via the corresponding I/O message connection. The data length is equivalent to the number of digital input data and rounded up to full bytes. In addition, a status byte is inserted.

Input 3 (I/O Assembly Instance 6):

The analog input data image and one status byte are transmitted to the master via the corresponding I/O message connection. The data length is equivalent to the number of analog input data in bytes and one status byte.

Input 1 (I/O Assembly Instance 7):

The entire input data image is transmitted to the master via the corresponding I/O message connection. The data length is equivalent to the number of input data in byte.

Input 2 (I/O Assembly Instance 8):

The digital input data image is transmitted to the master via the corresponding I/O message connection. The data length is equivalent to the number of digital input data and is rounded up to full bytes.

Input 3 (I/O Assembly Instance 9):

The analog input data image is transmitted to the master via the corresponding I/O message connection. The data length is equivalent to the number of analog input data in bytes.

5.6 Configuration / Parametering with the Object Model

5.6.1 EDS Files

In DeviceNet, the capacity characteristics of the devices are documented by the manufacturers in the form of an EDS file (Electronic Data Sheet) and made available to the user.

Architecture, contents and coding of the EDS files are standardized which permits design and configuration with devices of different manufacturers.

The EDS file is read by the configuration software and corresponding settings transmitted. For required entries and handling steps for this purpose, please refer to the software user manuals.



Further information

ODVA informs about the EDS files of all listed manufacturers.

<http://www.odva.org>

EDS and symbol files to configure the I/O modules are available under the order number PIO-912 on a floppy disk or on the PARKER INTERNET homepage.

<http://www.wago.com>

5.6.2 Object Model

For network communication DeviceNet uses an object model describing all device functions and data.

System Support Objects (general Management Objects)
• Identity Object
• Message Router Object
Communication Objects (Communications Objects for Data exchange)
• DeviceNet Object
• Connection Object
Application Objects (Application Objects, to determine device function and/or configuration)
• Application Object(s)
• Assembly Object
• Parameter Object

Table 5-1: Object model

Communication can be made exclusively connection oriented. For access by the network to the individual objects, first of all make connections between the desired subscribers and provide or allocate connection objects.

Data Type	
USINT	Unsigned Short INTegeR (8 Bit)
UINT	Unsigned INTegeR (16 Bit)
USINT	Unsigned Short INTegeR (8 Bit)
UDINT	Unsigned Double INTegeR (32 Bit)
BOOL	Boolean, True (1) or False (0)
STRUCT	Structure of ...
ARRAY	Array of ...

Object Model for Coupler

Classes of Coupler:

Object	Class	Instance	Description
Identity	0x01	1	Device type, vendor ID, serial number etc.
Message Router	0x02	1	Routes explicit messages to the proper destination.
DeviceNet	0x03	1	Maintains the physical connection to DeviceNet. This object also allocates/deallocates the Master/Slave connection set.
Assembly	0x04	9	Allows Data transmission of different objects over a single connection, by binding attributes of multiple objects.
Connection class	0x05	3	Allows explicit messages to be conducted.
Acknowledge handler	0x2B	1	The Acknowledge Handler Object is used to manage the reception of messages acknowledgements. This object communicates with a message producing application object within a device. The Acknowledge Handler Object notifies the producing application of acknowledge reception, acknowledge timeouts and production retry limit.
Coupler configuration object	0x64	1	Coupler and module configuration
Discrete input point	0x65	0...255	Digital input channel objects
Discrete output point	0x66	0...255	Digital output channel objects
Analog input point	0x67	0...16	Analog input channel objects
Analog output point	0x68	0...16	Analog output channel objects

Identity Class (0x01):

Instance 0:

Attribute ID	Used in buscoupler	Access rule	Name	Data type	Description	Value
1	required	get	Revision	UINT	Revision of the Identity Object, Range 1-65535, class definition upon which the implementation is based.	0x0001
2	optional	get	Max Instance	UINT	Maximum instance number	0x0001

Instance 1:

Attribute ID	Used in buscoupler	Access rule	Name	Data type	Description	Default Value
1	required	get	Vendor	UINT	Identification of vendor	40 (0x28)
2	required	get	Device Type	UINT	Indication of general type of product	12 (0x0C)
3	required	get	Product Code	UINT	Identification of particular product of an individual vendor	i. e. 346 (0x15A), for the PIO-346
4	required	get	Revision Major/Minor	Stuct: USINT, USINT	Revision of the item the Identity object represents	i. e. {1;2} for the PIO-346
5	required	get	Status	WORD	status of device	-
6	required	get	Serial_number	UDINT	Serial number of device	-
7	required	get	Product name	SHORT_STRING (num, char char...)	Human readable identification	i. e. „PIO-346“ for the PIO-346
10	optional	get	Heartbeat Interval	USINT	The nominal interval between heartbeat messages in seconds	0

Services:

Service Code	Service Name	Description
0x0E	Get_Attribute_Single	Returns the contents of the specified attribute
0x05	Reset	Invokes the reset service for the device

Message Router (0x02):

no attribute, no services

DeviceNet Object (0x03):**Instance 0:**

Attribute ID	Used in buscoupler	Access rule	Name	Data type	Description	Default Value
1	required	get	Revision	UINT	Revision of the Identity Object, Range 1-65535, class definition upon which the implementation is based.	0x02

Instance 1:

Attribute ID	Used in buscoupler	Access rule	Name	Data type	Description	Default Value
1	Optional	get	MAC ID	USINT	Node address	0 - 63
2	Optional	get	Baud Rate	USINT	Baud rate	0 - 2
3	Optional	get/set	BOI	BOOL	Bus-off Interrupt	0/1
4	Optional	get/set	Bus-Off Counter	USINT	Number of times CAN went to the bus-off state	0 - 255
5	Optional	get	Allocation Information Allocation Choice Byte Master's ID	Struct of: BYTE, USINT	s. MAC ID of Master (from Allocate)	0 - 63, 255

Services:

Service Code	Service Name	Description
0x0E	Get_Attribute_Single	Used to read a DeviceNet Object attribute value
0x10	Set_Attribute_Single	Used to modify a DeviceNet object attribute value
0x4B	Allocate_Master/Slave_Connection	Requests the use of the predefined Master/Slave connection
0x4C	Release_Group_2_Identifier_Set	Indicates that the specified connections within the predefined Master/Slave connection set are no longer desired. These connections are to be released (deleted)

Assembly Object (0x04):**Instance 0:**

Attribute ID	Used in buscoupler	Access rule	Name	Data type	Description	Value
1	required	get	Revision	UINT	Revision of the Identity Object, Range 1-65535, class definition upon which the implementation is based.	0x0002

Description of the Instances:

Instance ID	Description
1	References to the process image containing analog and digital output data.
2	References to the process image containing only digital output data.
3	References to the process image containing only analog output data.
4	References to the process image containing containing analog and digital input data plus status.
5	References to the process image containing only digital input data plus status.
6	References to the process image containing only analog input data plus status.
7	References to the process image containing analog and digital input data.
8	References to the process image containing only analog input data.
9	References to the process image containing only analog input data.

Instance 1:

Attribute ID	Used in buscoupler	Access rule	Name	Data type	Description	Value
3	dep. on kind of connected modules	get/set	Process image	Array of Byte	process image, collection of all modules process output data.	

Instance 2:

Attribute ID	Used in buscoupler	Access rule	Name	Data type	Description	Value
3	dep. on kind of connected modules	get/set	Process image	Array of Byte	process image, collection of all modules process output data.	

Instance 3:

Attribute ID	Used in buscoupler	Access rule	Name	Data type	Description	Value
3	dep. on kind of connected modules	get/set	Process image	Array of Byte	process image, collection of all analog modules process output data.	

Instance 4:

Attribute ID	Used in buscoupler	Access rule	Name	Data type	Description	Value
3	dep. on kind of connected modules	get/set	Process image	Array of Byte	process image, collection of all modules process input data plus status byte.	

Instance 5:

Attribute ID	Used in buscoupler	Access rule	Name	Data type	Description	Value
3	dep. on kind of connected modules	get/set	Process image	Array of Byte	process image, collection of all digital modules process input data plus status byte.	

Instance 6:

Attribute ID	Used in buscoupler	Access rule	Name	Data type	Description	Value
3	dep. on kind of connected modules	get/set	Process image	Array of Byte	process image, collection of all analog modules process input data plus status byte.	

Instance 7:

Attribute ID	Used in buscoupler	Access rule	Name	Data type	Description	Value
3	dep. on kind of connected modules	get/set	Process image	Array of Byte	process image, collection of all modules process input data	

Instance 8:

Attribute ID	Used in buscoupler	Access rule	Name	Data type	Description	Value
3	dep. on kind of connected modules	get/set	Process image	Array of Byte	process image, collection of all digital modules process input data	

Instance 9:

Attribute ID	Used in buscoupler	Access rule	Name	Data type	Description	Value
3	dep. on kind of connected modules	get/set	Process image	Array of Byte	process image, collection of all analog modules process input data	

Services:

Service Code	Service Name	Description
0x0E	Get_Attribute_Single	Used to read a DeviceNet Object attribute value
0x10	Set_Attribute_Single	Used to modify a DeviceNet object attribute value

Connection Object (0x05):

Instance 0:

Attribute ID	Used in buscoupler	Access rule	Name	Data type	Description	Default Value
1	required	get	Revision	UINT	Revision of the Identity Object, Range 1-65535, class definition upon which the implementation is based.	0x0001

Description of the instances:

Instance ID	Description
1	References the Explicit Messaging Connection into the Server
2	References the Poll I/O Connection
3	References Bit-Strobe I/O Connection
4	References the Slave's Change of State or Cyclic I/O Connection
5	Reserved for „Reserved Identifier“, Message ID 1

Instance 1 (explicit messaging):

Attribute ID	Used in buscoupler	Access rule	Name	Data type	Description
1	available	get	state	USINT	State of the object
2	required	get	instance_type	USINT	Indicates either I/O or Messaging Connection
3	required	get	transportClass_trigger	USINT	defines behaviour of the connection
4	required	get	produced_connection_id	UINT	CAN Identifier field when the connection transmits
5	required	get	consumed_connection_id	UINT	CAN Identifier field value that denotes message to be received
6	required	get	initial_comm_characteristics	USINT	Defines the message groups across which productions and consumptions associated with this connection occur
7	required	get	produced_connection_size	UINT	maximum number of Bytes transmitted across this connection
8	required	get	consumed_connection_size	UINT	maximum number of Bytes transmitted across this connection
9	required	get/set	expected_packet_rate	UINT	defines timing associated with this connection
10-11	N/A	get	N/A	N/A	not used
12	required	get	watchdog_timeout_action	USINT	defines how to handle inactivity/watchdog timeouts
13	required	get	produced_connection_path_length	UINT	number of Bytes in produced_connection_path attribute
14	required	get/set	produced_connection_path	Array of USINT	specifies the application objects which data is to be produced by this connection object
15	required	get	consumed_connection_path_length	UINT	number of Bytes in consumed_connection_path attribute
16	required	get	consumed_connection_path	Array of USINT	specifies the application objects that are to receive the data consumed by this connection object
17	required	get	production_inhibit_time	USINT	defines minimum time between new data production

Instance 2 (Poll I/O Connection):

Attribute ID	Used in buscoupler	Access rule	Name	Data type	Description
1	available	get	state	USINT	State of the object
2	required	get	instance_type	USINT	Indicates either I/O or Messaging Connection
3	required	get	TransportClass_trigger	USINT	Defines behaviour of the connection
4	required	get	produced_connection_id	UINT	CAN Identifier field when the connection transmits
5	required	get	consumed_connection_id	UINT	CAN Identifier field value that denotes message to be received
6	required	get	initial_comm_characteristics	USINT	Defines the message groups across which productions and consumptions associated with this connection occur
7	required	get	produced_connection_size	UINT	maximum number of Bytes transmitted across this connection
8	required	get	consumed_connection_size	UINT	maximum number of Bytes received across this connection
9	required	get/set	expected_packet_rate	UINT	defines timing associated with this connection
10-11	N/A	get	N/A	N/A	not used
12	required	get	watchdog_timeout_action	USINT	defines how to handle inactivity/watchdog timeouts
13	required	get	produced_connection_path_length	UINT	number of Bytes in produced_connection_path attribute
14	required	get/set	produced_connection_path	Array of USINT	specifies the application objects which data is to be produced by this connection object
15	required	get	consumed_connection_path_length	UINT	number of Bytes in consumed_connection_path attribute
16	required	get/set	consumed_connection_path	Array of USINT	specifies the application objects that are to receive the data consumed by this connection object
17	required	get	production_inhibit_time	USINT	defines minimum time between new data production

Instance 3 (Bit-Strobe I/O Connection):

Attribute ID	Used in buscoupler	Access rule	Name	Data type	Description
1	available	get	state	USINT	State of the object
2	required	get	instance_type	USINT	Indicates either I/O or Messaging Connection
3	required	get	TransportClass_trigger	USINT	defines behaviour of the connection
4	required	get	produced_connection_id	UINT	CAN Identifier field when the connection transmits
5	required	get	consumed_connection_id	UINT	CAN Identifier field value that denotes message to be received
6	required	get	initial_comm_characteristics	USINT	Defines the message groups across which productions and consumptions

					associated with this connection occur
7	required	get	produced_connection_size	UINT	maximum number of Bytes transmitted across this connection
8	required	get	consumed_connection_size	UINT	maximum number of Bytes received across this connection
9	required	get/set	expected_packet_rate	UINT	defines timing associated with this connection
10-11	N/A	get	N/A	N/A	not used
12	required	get	watchdog_timeout_action	USINT	defines how to handle inactivity/watchdog timeouts
13	required	get	produced_connection_path_length	UINT	number of Bytes in produced_connection_path attribute
14	required	get	produced_connection_path	Array of USINT	specifies the application objects which data is to be produced by this connection object
15	required	get	consumed_connection_path_length	UINT	number of Bytes in consumed_connection_path attribute
16	required	get	consumed_connection_path	Array of USINT	specifies the application objects that are to receive the data consumed by this connection object
17	required	get	production_inhibit_time	USINT	defines minimum time between new data production

Instance 4 (Change of State and Cyclic I/O Connection):

Attribute ID	Used in buscoupler	Access rule	Name	Data type	Description
1	available	get	state	USINT	State of the object
2	required	get	instance_type	USINT	Indicates either I/O or Messaging Connection
3	required	get	transportClass_trigger	USINT	defines behaviour of the connection
4	required	get	produced_connection_id	UINT	CAN Identifier field when the connection transmits
5	required	get	consumed_connection_id	UINT	CAN Identifier field value that denotes message to be received
6	required	get	initial_comm_characteristics	USINT	Defines the message groups across which productions and consumptions associated with this connection occur
7	required	get	produced_connection_size	UINT	maximum number of Bytes transmitted across this connection
8	required	get	consumed_connection_size	UINT	maximum number of Bytes received across this connection
9	required	get/set	expected_packet_rate	UINT	defines timing associated with this connection
10-11	N/A	get	N/A	N/A	not used
12	required	get	watchdog_timeout_action	USINT	defines how to handle inactivity/watchdog timeouts
13	required	get	produced_connection_path_length	UINT	number of Bytes in produced_connection_path attribute
14	required	get/set	produced_connection_path	Array of USINT	specifies the application objects which data is to be produced by this

					connection object
15	required	get	consumed_ connection_ path_ length	UINT	number of Bytes in consumed_ connection_ path attribute
16	required	get	consumed_ connection_ path	Array of USINT	specifies the application objects that are to receive the data consumed by this connection object
17	required	get/set	production_ inhibit_ time	USINT	defines minimum time between new data production

Services:

Service Code	Service Name	Description
0x0E	Get_Attribute_Single	Used to read a DeviceNet Object attribute value
0x10	Set_Attribute_Single	Used to modify a DeviceNet object attribute value
0x05	Reset	Restores connection default values.

The instances are not available if the connection is in state „non existent“.

I/O Connection Object State

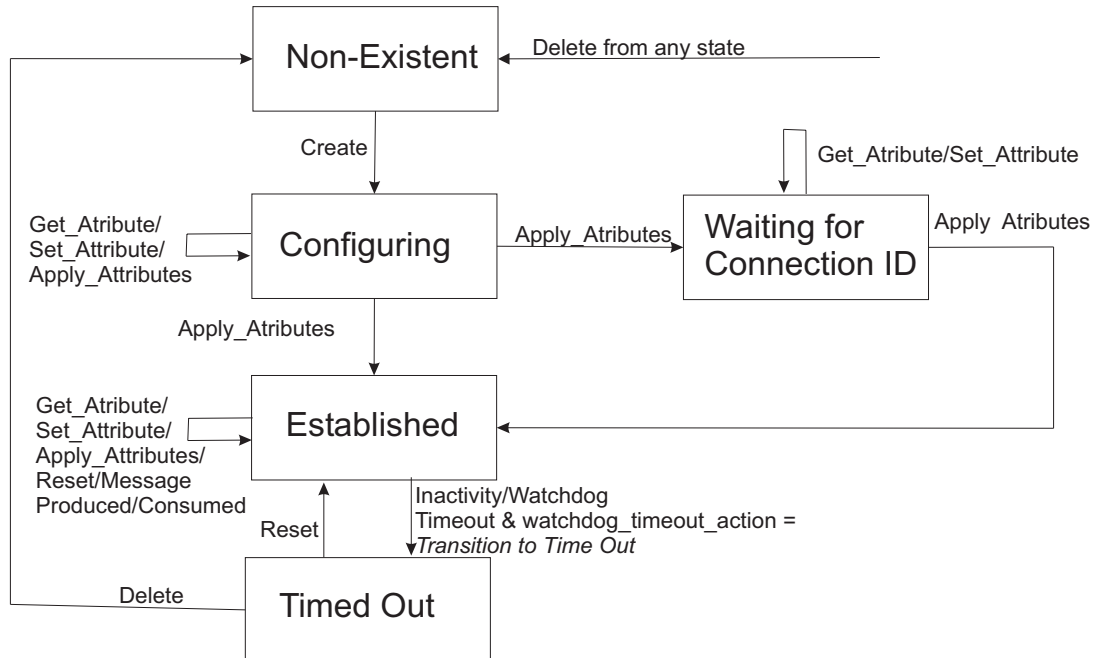

Fig. 5-1: Status of I/O Connection Objects

Acknowledge Handler Object (0x2B):

Instance 0:

Attribute ID	Used in buscoupler	Access rule	Name	Data type	Description	Value
1	required	get	Revision	UINT	Revision of the Identity Object, Range 1-65535, class definition upon which the implementation is based.	0x0001
2	required	get	Max instance	UINT	maximum instance number of an object currently created in this class level of device	0x0001

Instance 1:

Attribute ID	Used in buscoupler	Access rule	Name	Data type	Description
1	required	get/set	Acknowledge timer	UINT	time to wait for acknowledge before resending range 1-65,535 ms (0 invalid), default 16 ms
2	required	get/set	Retry limit	USINT	number of ack timeouts to wait before informing the producing application of a RetryLimit_Reached event default=1, range 0-255; default 16 ms
3	required	get	COS Producing Connection Instance	UINT	0x04, connection instance which contains the path of the producing I/O application object which will be notified of ack handler objects
4	Optional	Get	Ack List Size	BYTE	Maximum number of members in Ack List.
5	Optional	Get	Ack List	BYTE Array of UINT	List of active connection instances which are receiving Acks.
6	Optional	Get	Data with Ack Path List Size	BYTE	Maximum number of members in Data with Ack Path List.
7	Optional	get	Data with Ack Path List	BYTE Array of UINT USINT Array of USINT	List of active connection instance/consuming application object pairs. This attribute is used to forward data received with acknowledgment.

Services:

Service Code	Service Name	Description
0x0E	Get_Attribute_Single	Used to read a DeviceNet Object attribute value
0x10	Set_Attribute_Single	Used to modify a DeviceNet object attribute value

Coupler Configuration Object (0x64):

Instance 0:

Attribute ID	Used in buscoupler	Access rule	Name	Data type	Description	Value
1	required	get	Revision	UINT	Revision of the Identity Object, Range 1-65535, class definition upon which the implementation is based.	0x01
2	required	get	Max instance	UINT	maximum instance number of an object currently created in this class level of device	0x01

Instance 1:

Attribute ID	Used in buscoupler	Access rule	Name	Data type	Description
1	specific	get/set	Bk_ModuleNo	USINT	module number: 0-coupler, 1- first module, 2-2.module
2	specific	get/set	Bk_TableNo	USINT	table number: 0 ... 256; not all existing
3	specific	get/set	Bk_RegisterNo	USINT	Register number: 0...255 for the coupler (0...63 for modules)
4	specific	get/set	Bk_Data	UINT	Register data , Status
5	specific	get	ProcessState	USINT	coupler status: 0x01 module communication error, 0x08: module diagnostic , 0x80 fieldbus error

6	specific	get	DNS_i_TrmIdia (**)	UINT	Module status, 0x8000 to decode a message, High Byte (Bit14..8): channel number, Low Byte (Bit7..0) Module number
7	specific	get	CnfLen. AnalogOut	UINT	number of I/O Bits for analog output data words
8	specific	get	CnfLen. AnalogInp	UINT	number of I/O Bits for analog input data words
9	specific	get	CnfLen. DigitalOut	UINT	number of I/O Bits for digital output data bits
10	specific	get	CnfLen. DigitalInp	UINT	number of I/O Bits for digital input data bits
11	specific	get/set	BK_FAULT_REACTION	USINT	An enumerator used to specify fieldbus error handling 0: stop local I/O cycles (default) 1: switch all outputs to 0 2: do nothing 3: switch all outputs to a predefined output image
12	specific	get/set	BK_SEL_STORED_POLL_P_PATH	UINT	Non volatile power up value for the polled I/O produced connection path. The attribute is used to hold an enumerator for the assembly path and the class and instance for the modules object (discrete input point...) paths. Write only instance values that are available for couplers present module configuration. (e.g. do not use analog input points if only digital modules are fixed to the coupler. 0: bad value, path value not visible 1: analog and digital output data 2: only digital output data 3: only analog output data 4: analog and digital input data, status 5: only digital input data plus status 6: only analog input data plus status 7: analog and digital input data 8: only digital input data 9: only analog input data
13	specific	get/set	BK_SEL_STORED_POLL_C_PATH	UINT	Non volatile power up value for the polled I/O consumed connection path. The attribute is used to hold an enumerator for the assembly path and the class and instance for modules object (discrete input point ...) paths. Write only instance values that are available for couplers present module configuration (e.g. do not use analog input points if only digital modules are fixed to the coupler.
14	specific	get/set	BK_SEL_STORED_COSCYC_C_PATH	UINT	Non volatile power up value for the change of state and cyclic connection path. The attribute is used to hold an enumerator for the assembly path and the class and instance for modules object (discrete input point...) paths. Write only instance values that are available for couplers present module configuration (e.g. Digital Ausgang not use analog input points if only digital modules are fixed to the coupler.
15	specific	get/set	BK_EM_expected_packet_rate	UINT	Defines the default timing associated with this Explicit Messaging Connection

16	specific	get/set	BK_EM_watchdog_timeout_action	USINT	Defines how to handle Inactivity/Watchdog Explicit Messaging Connection timeouts
17	specific	get/set	BK_PIO_expected_packet_rate	UINT	Defines the default timing associated with this Poll I/O Connection
18	specific	get/set	BK_PIO_watchdog_timeout_action	USINT	Defines how to handle Inactivity/Watchdog Poll I/O Connection Connection timeouts
19	specific	get/set	BK_BS_expected_packet_rate	UINT	Defines the default timing associated with this Bit-Strobe I/O Connection
20	specific	get/set	BK_BS_watchdog_timeout_action	USINT	Defines how to handle Inactivity/Watchdog Bit-Strobe I/O Connection Connection timeouts
21	specific	get/set	BK_COS_expected_packet_rate	UINT	Defines the default timing associated with this Change of State and Cyclic I/O Connection
22	specific	get/set	BK_COS_watchdog_timeout_action	USINT	Defines how to handle Inactivity/Watchdog Change of State and Cyclic I/O Connection timeouts
23	specific	get/set	BK_BOI	USINT	Defines the default value for BOI(Obj0x3 Inst. 1 Att. 3. It handles the CAN Bus-Off situation. 0: Hold the CAN chip in its bus-off (reset) state upon detection of a bus-off indication 1: If possible, fully reset the CAN chip and continue communicating upon detection of a bus-off indication
24	specific	get/set	BK_DO_FAULT_REACTION_ON_RELEASE_PIO	USINT	Defines the behavior after de allocation the polled I/O connection 0: (default) do nothing 1: Process the coupler fault reaction
25	specific	get/set	BK_DO_FAULT_REACTION_ON_RELEASE_COS	USINT	Defines the behavior after de allocation the Change of State and Cyclic I/O Connection 0: (default) do nothing 1: Process the coupler fault reaction
26	specific	get/set	BK_DO_FAULT_REACTION_ON_RELEASE_ST	USINT	Defines the behavior after de allocation the strobed Connection 0: (default) do nothing 1: Process the coupler fault reaction
40	specific	get/set	BK_static_analog_digital_input_mapping	UINT	Defines how to calculate the values for the number of analog and digital input bits. 0000: All bits are digital 0016: One word is analog remaining bits are digital 0032: Two words are analog remaining bits are digital ... 0xFFFF: All bits are handled like module type (default)

41	specific	get/set	BK_static_analog_digital_output_mapping	UINT	Defines how to calculate the values for the number of analog and digital input bits. 0000: All bits are digital 0016: One word is analog remaining bits are digital 0032: Two words are analog remaining bits are digital ... 0xFFFF: All bits are handled like module type (default) (If the number of analog bits exceeds the size of the process image all bits are mapped to analog bits.
42	specific	get/set	BK_specific_coupler_behavior	UINT	Defines the couplers functionality. 0xFFFF: All possible functions are enabled. (resetting a bit to 0 disables the assigned functionality). It is only possible to reduce the functionality. Resetting to „1“ is ignored.
43	specific	get/set	BK_revision_setting	UINT	Defines the couplers major and minor revision attribute. 0xFFFF: The major and minor revision Attributes are set by the firmware. (This is the default behavior). 0x??00: The minor revision is set to 0. 0x03??: The major revision is set to 3. All other values are valid to.

() Object 100 (0x64) Instance 1 Attribute 6**

The attribute DNS_i_Trmndia is set depending on the state of the node, i. e. it will be execute a diagnostic evaluation. This word will only supply valid data, if bit 3 (count up from 0) in ProcessState (class 100/Inst1/Attr.5) is set. This bit indicates, that a new diagnostic notification is present (see description ProcessState).

The diagnostic evaluation is done by bit 15 in the attribute DNS_i_Trmndia.

If a diagnostic error appears, bit 15 is set.

If an error is rectified, bit 15 is reset.

As long as at least one diagnostic error is present, the MS LED is blinking red.

If there are a lot of diagnostic notifications at the same time, with every readout of this attribute you get the next diagnostic notification. If DNS_i_Trmndia = 0, there is current no new diagnostic notification.

The MS LED changes on green again, not until the readout of the last diagnostic notification (only if the diagnostic reason is solved).

Services:

Service Code	Service Name	Description
0x0E	Get_Attribute_Single	Used to read a DeviceNet Object attribute value
0x10	Set_Attribute_Single	Used to modify a DeviceNet object attribute value

Discrete Input Point Object (0x65):

Instance 0:

Attribute ID	Used in buscoupler	Access rule	Name	Data type	Description	Value
1	required	get	Revision	UINT	Revision of the Identity Object, Range 1-65535, class definition upon which the implementation is based.	0x01
2	optional	get	Max instance	UINT	maximum number of instances of an object currently created in this class level of the device	0x00ff

Description of the instances:

Instance ID	Description
1	Reference to the first digital input point
2	Reference to the next digital input point
...	
255	Reference to the last possible digital input point

Instance 1 to 255:

Attribute ID	Used in buscoupler	Access rule	Name	Data type	Description	Value
1	dep. on kind of connected modules	get	DIPOBJ_VALUE	BIT	digital input bit	0:off 1:on

Services:

Service Code	Service Name	Description
0x0E	Get_Attribute_Single	Used to read an object attribute value.

Discrete Output Point Object (0x66):

Instance 0:

Attribute ID	Used in buscoupler	Access rule	Name	Data type	Description	Value
1	required	get	Revision	UINT	Revision of the Identity Object, Range 1-65535, class definition upon which the implementation is based.	0x01
2	optional	get	Max instance	UINT	maximum instance number of an object currently created in this class level of device	0x00ff

Description of the instances:

Instance ID	Description
1	Reference to the first digital output point
2	Reference to the next digital output point
...	
255	Reference to the last possible digital output point

Instance 1 to 255:

Attribute ID	Used in buscoupler	Access rule	Name	Data type	Description	Value
1	dep. on kind of connected modules	get/set	DOPOBJ_VALUE	BIT	digital output bit	0:off 1:on

Services:

Service Code	Service Name	Description
0x0E	Get_Attribute_Single	Used to read a DeviceNet Object attribute value
0x10	Set_Attribute_Single	Used to modify a DeviceNet object attribute value

Analog Input Point Object (0x67):**Instance 0:**

Attribute ID	Used in buscoupler	Access rule	Name	Data type	Description	Value
1	required	get	Revision	UINT	Revision of the Identity Object, Range 1-65535, class definition upon which the implementation is based.	0x0001
2	optional	get	Max instance	UINT	maximum instance number of an object currently created in this class level of device	0x0010

Description of the instances:

Instance ID	Description
1	reference to the first analog input point
2	reference to the next analog input point
...	
16	reference to the last possible analog input point

Instance 1 to 16:

Attribute ID	Used in buscoupler	Access rule	Name	Data type	Description	Value
1	dep. on kind of connected modules	get	AIPOBJ_VALUE	Array of Byte	Input data	actual input Values
2	dep. on kind of connected modules	get	AIPOBJ_VALUE	USINT	Input data length	Number of Bytes

Services:

Service Code	Service Name	Description
0x0E	Get_Attribute_Single	Used to read a DeviceNet Object attribute value
0x10	Set_Attribute_Single	Used to modify a DeviceNet object attribute value

Analog Output Point Object (0x68):**Instance 0:**

Attribute ID	Used in buscoupler	Access rule	Name	Data type	Description	Value
1	required	get	Revision	UINT	Revision of the Identity Object, Range 1-65535, class definition upon which the implementation is based.	0x01
2	optional	get	Max instance	UINT	maximum instance number of an object currently created in this class level of device	0x0010

Description of the instances:

Instance ID	Description
1	reference to the first analog output point
2	reference to the next analog output point
...	
16	reference to the last possible analog output point

Instance 1 bis 16:

Attribute ID	Used in buscoupler	Access rule	Name	Data type	Description	Value
1	dep. on kind of connected modules	get	AOPOBJ_VALUE	Array of Byte	output data	actual output value
2	dep. on kind of connected modules	get	AOPOBJ_VALUE	USINT	output data length	number of Bytes

Services:

Service Code	Service Name	Description
0x0E	Get_Attribute_Single	Used to read a DeviceNet Object attribute value
0x10	Set_Attribute_Single	Used to modify a DeviceNet object attribute value

6 Use in Hazardous Environments

6.1 Foreword

Today's development shows that many chemical and petrochemical companies have production plants, production, and process automation machines in operation which use gas-air, vapor-air and dust-air mixtures which can be explosive. For this reason, the electrical components used in such plants and I/O-systems must not pose a risk of explosion resulting in injury to persons or damage to property. This is backed by law, directives or regulations on a national and international scale. The I/O-SYSTEM (electrical components) is designed for use in zone 2 explosive environments. The following basic explosion protection related terms have been defined.

6.2 Protective measures

Primarily, explosion protection describes how to prevent the formation of an explosive atmosphere. For instance by avoiding the use of combustible liquids, reducing the concentration levels, ventilation measures, to name but a few. But there are a large number of applications, which do not allow the implementation of primary protection measures. In such cases, the secondary explosion protection comes into play. Following is a detailed description of such secondary measures.

6.3 Classification meeting CENELEC and IEC

The specifications outlined here are valid for use in Europe and are based on the following standards: EN50... of CENELEC (European Committee for Electrotechnical Standardization). On an international scale, these are reflected by the IEC 60079-... standards of the IEC (International Electrotechnical Commission).

6.3.1 Divisions

Explosive environments are areas in which the atmosphere can potentially become explosive. The term explosive means a special mixture of ignitable substances existing in the form of air-borne gases, fumes, mist or dust under atmospheric conditions which, when heated beyond a tolerable temperature or subjected to an electric arc or sparks, can produce explosions. Explosive zones have been created to describe the concentrations level of an explosive atmosphere. This division, based on the probability of an explosion occurring, is of great importance both for technical safety and feasibility reasons. Knowing that the demands placed on electrical components permanently employed in an explosive environment have to be much more stringent than those placed on electrical components that are only rarely and, if at all, for short periods, subject to a dangerous explosive environment.

Explosive areas resulting from gases, fumes or mist:

- Zone 0 areas are subject to an explosive atmosphere (> 1000 h /year) continuously or for extended periods.
- Zone 1 areas can expect the occasional occurrence of an explosive atmosphere (> 10 h ≤ 1000 h /year).
- Zone 2 areas can expect the rare or short-term occurrence of an explosive atmosphere (> 0 h ≤ 10 h /year).

Explosive areas subject to air-borne dust:

- Zone 20 areas are subject to an explosive atmosphere (> 1000 h /year) continuously or for extended periods.
- Zone 21 areas can expect the occasional occurrence of an explosive atmosphere (> 10 h ≤ 1000 h /year).
- Zone 22 areas can expect the rare or short-term occurrence of an explosive atmosphere (> 0 h ≤ 10 h /year).

6.3.2 Explosion protection group

In addition, the electrical components for explosive areas are subdivided into two groups:

- Group I: Group I includes electrical components for use in fire-damp endangered mine structures.
- Group II: Group II includes electrical components for use in all other explosive environments. This group is further subdivided by pertinent combustible gases in the environment. Subdivision IIA, IIB and IIC takes into account that different materials/substances/gases have various ignition energy characteristic values. For this reason the three sub-groups are assigned representative types of gases:
 - IIA – Propane
 - IIB – Ethylene
 - IIC – Hydrogen

Minimal ignition energy of representative types of gases				
Explosion group	I	IIA	IIB	IIC
Gases	Methane	Propane	Ethylene	Hydrogen
Ignition energy (µJ)	280	250	82	16

Hydrogen being commonly encountered in chemical plants, frequently the explosion group IIC is requested for maximum safety.

6.3.3 Unit categories

Moreover, the areas of use (zones) and the conditions of use (explosion groups) are subdivided into categories for the electrical operating means:

Unit categories	Explosion groups	Area of use
M1	I	Fire-damp protection
M2	I	Fire-damp protection
1G	II	Zone 0 Explosive environment by gas, fumes or mist
2G	II	Zone 1 Explosive environment by gas, fumes or mist
3G	II	Zone 2 Explosive environment by gas, fumes or mist
1D	II	Zone 20 Explosive environment by dust
2D	II	Zone 21 Explosive environment by dust
3D	II	Zone 22 Explosive environment by dust

6.3.4 Temperature classes

The maximum surface temperature for electrical components of explosion protection group I is 150 °C (danger due to coal dust deposits) or 450 °C (if there is no danger of coal dust deposit).

In line with the maximum surface temperature for all ignition protection types, the electrical components are subdivided into temperature classes, as far as electrical components of explosion protection group II are concerned. Here the temperatures refer to a surrounding temperature of 40 °C for operation and testing of the electrical components. The lowest ignition temperature of the existing explosive atmosphere must be higher than the maximum surface temperature.

Temperature classes	Maximum surface temperature	Ignition temperature of the combustible materials
T1	450 °C	> 450 °C
T2	300 °C	> 300 °C to 450 °C
T3	200 °C	> 200 °C to 300 °C
T4	135 °C	> 135 °C to 200 °C
T5	100 °C	>100 °C to 135 °C
T6	85°C	> 85 °C to 100 °C

The following table represents the division and attributes of the materials to the temperature classes and material groups in percent:

Temperature classes						
T1	T2	T3	T4	T5	T6	Total*
26.6 %	42.8 %	25.5 %				
94.9 %			4.9 %	0 %	0.2 %	432
Explosion group						
IIA	IIB	IIC				Total*
85.2%	13.8 %	1,0 %				501

* Number of classified materials

6.3.5 Types of ignition protection

Ignition protection defines the special measures to be taken for electrical components in order to prevent the ignition of surrounding explosive atmospheres. For this reason a differentiation is made between the following types of ignition protection:

Identifi- cation	CENELEC standard	IEC standard	Explanation	Application
EEx o	EN 50 015	IEC 79-6	Oil encapsulation	Zone 1 + 2
EEx p	EN 50 016	IEC 79-2	Overpressure encapsulation	Zone 1 + 2
EEx q	EN 50 017	IEC 79-5	Sand encapsulation	Zone 1 + 2
EEx d	EN 50 018	IEC 79-1	Pressure resistant encapsulation	Zone 1 + 2
EEx e	EN 50 019	IEC 79-7	Increased safety	Zone 1 + 2
EEx m	EN 50 028	IEC 79-18	Cast encapsulation	Zone 1 + 2
EEx i	EN 50 020 (unit) EN 50 039 (system)	IEC 79-11	Intrinsic safety	Zone 0 + 1 + 2
EEx n	EN 50 021	IEC 79-15	Electrical components for zone 2 (see below)	Zone 2

Ignition protection "n" describes exclusively the use of explosion protected electrical components in zone 2. This zone encompasses areas where explosive atmospheres can only be expected to occur rarely or short-term. It represents the transition between the area of zone 1, which requires an explosion protection and safe area in which for instance welding is allowed at any time.

Regulations covering these electrical components are being prepared on a world-wide scale. The standard EN 50 021 allows electrical component manufacturers to obtain certificates from the corresponding authorities for instance KEMA in the Netherlands or the PTB in Germany, certifying that the tested components meet the above mentioned standards draft.

Type "n" ignition protection additionally requires electrical components to be marked with the following extended identification:

- A – non spark generating (function modules without relay /without switches)

- AC – spark generating, contacts protected by seals (function modules with relays / without switches)
- L – limited energy (function modules with switch)



Further information

For more detailed information please refer to the national and/or international standards, directives and regulations!

6.4 Classifications meeting the NEC 500

The following classifications according to NEC 500 (National Electric Code) are valid for North America.

6.4.1 Divisions

The "Divisions" describe the degree of probability of whatever type of dangerous situation occurring. Here the following assignments apply:

Explosion endangered areas due to combustible gases, fumes, mist and dust:	
Division 1	Encompasses areas in which explosive atmospheres are to be expected occasionally ($> 10 \text{ h} \leq 1000 \text{ h /year}$) as well as continuously and long-term ($> 1000 \text{ h /year}$).
Division 2	Encompasses areas in which explosive atmospheres can be expected rarely and short-term ($> 0 \text{ h} \leq 10 \text{ h /year}$).

6.4.2 Explosion protection groups

Electrical components for explosion endangered areas are subdivided in three danger categories:

Class I (gases and fumes):	Group A (Acetylene) Group B (Hydrogen) Group C (Ethylene) Group D (Methane)
Class II (dust):	Group E (Metal dust) Group F (Coal dust) Group G (Flour, starch and cereal dust)
Class III (fibers):	No sub-groups

6.4.3 Temperature classes

Electrical components for explosive areas are differentiated by temperature classes:

Temperature classes	Maximum surface temperature	Ignition temperature of the combustible materials
T1	450 °C	> 450 °C
T2	300 °C	> 300 °C to 450 °C
T2A	280 °C	> 280 °C to 300 °C
T2B	260 °C	> 260 °C to 280 °C
T2C	230 °C	>230 °C to 260 °C
T2D	215 °C	>215 °C to 230 °C
T3	200 °C	>200 °C to 215 °C
T3A	180 °C	>180 °C to 200 °C
T3B	165 °C	>165 °C to 180 °C
T3C	160 °C	>160 °C to 165 °C
T4	135 °C	>135 °C to 160 °C
T4A	120 °C	>120 °C to 135 °C
T5	100 °C	>100 °C to 120 °C
T6	85 °C	> 85 °C to 100 °C

6.5 Identification

6.5.1 For Europe

According to CENELEC and IEC

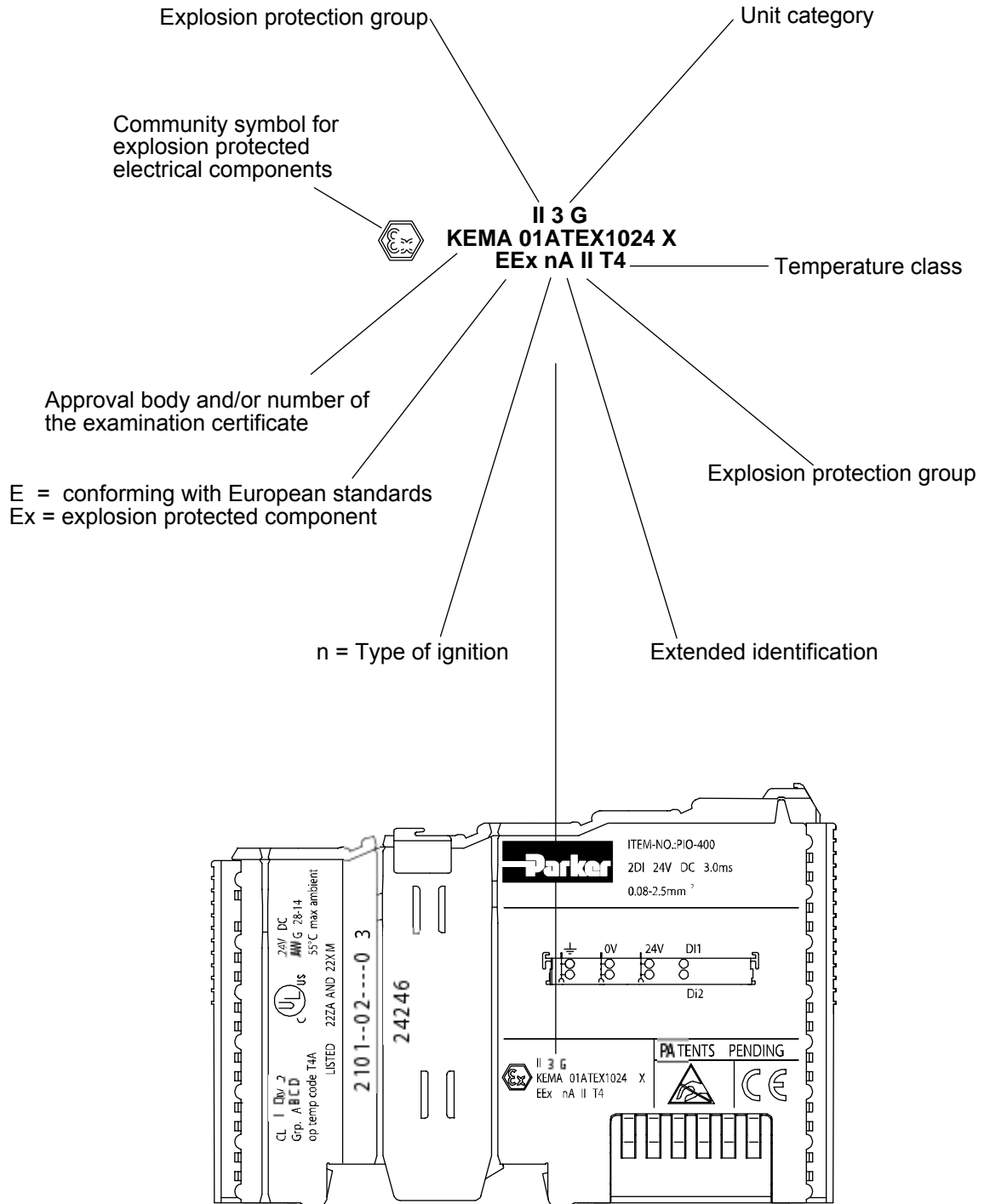

Fig. 6-1: Example for lateral labeling of bus modules (PIO-400, 2 channel digital input module 24 V DC)

6.5.2 For America

According to NEC 500

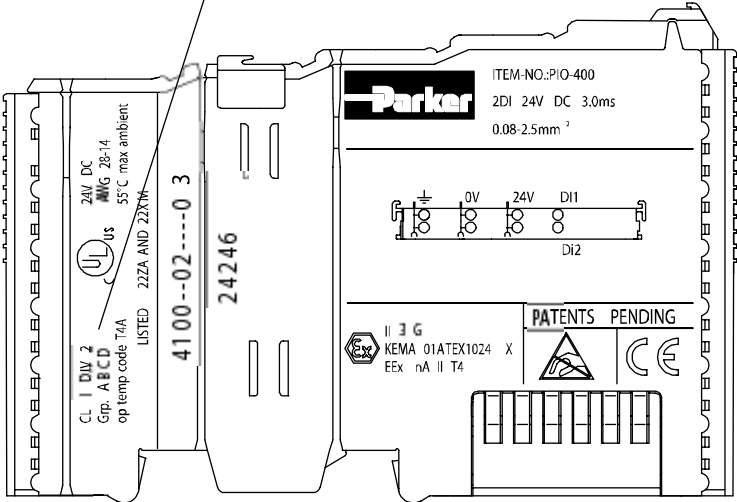
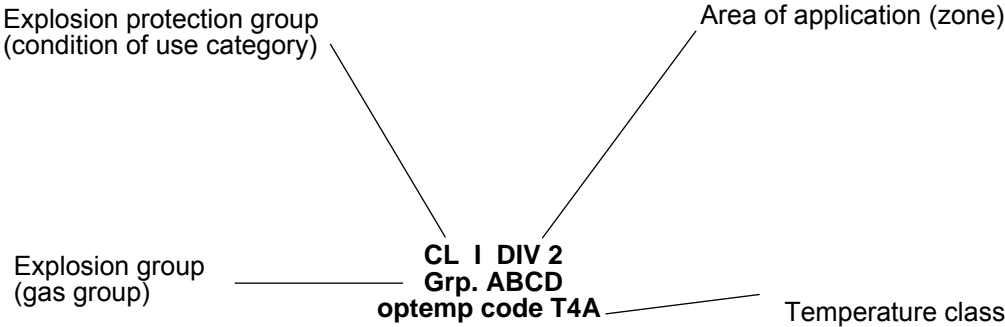

Fig. 6-2: Example for lateral labeling of bus modules (PIO-400, 2 channel digital input module 24 V DC)

6.6 Installation regulations

In the **Federal Republic of Germany**, various national regulations for the installation in explosive areas must be taken into consideration. The basis being the ElexV complemented by the installation regulation DIN VDE 0165/2.91. The following are excerpts from additional VDE regulations:

DIN VDE 0100	Installation in power plants with rated voltages up to 1000 V
DIN VDE 0101	Installation in power plants with rated voltages above 1 kV
DIN VDE 0800	Installation and operation in telecommunication plants including information processing equipment
DIN VDE 0185	lightning protection I/O-systems

The **USA** and **Canada** have their own regulations. The following are excerpts from these regulations:

NFPA 70	National Electrical Code Art. 500 Hazardous Locations
ANSI/ISA-RP 12.6-1987	Recommended Practice
C22.1	Canadian Electrical Code



- **Danger**

When using the I/O-SYSTEM (electrical operation) with Ex approval, the following points are mandatory:

- A. The fieldbus independent I/O-system Modules Type PIO-xxx are to be installed in enclosures that provide for the degree of ingress protection of at least IP54. For use in the presence of combustible dust, the above mentioned modules are to be installed in enclosures that provide for the degree of ingress protection of at least IP64.
- B. The fieldbus independent I/O-system may only be installed in hazardous areas (Europe: Group II, Zone 2 or America: Class I, Division 2, Group A, B, C, D) or in non-hazardous areas!
- C. Installation, connection, addition, removal or replacement of modules, fieldbus connectors or fuses may only take place when the I/O-system supply and the field supply are switched off, or when the area is known to be non-hazardous.
- D. Ensure that only approved modules of the electrical operating type will be used. The Substitution or Replacement of modules can jeopardize the suitability of the I/O-system in hazardous environments!
- E. Operation of intrinsically safe EEx i modules with direct connection to sensors/actuators in hazardous areas of Zone 0 + 1 and Division 1 type requires the use of a 24 V DC Power Supply EEx i module!
- F. DIP switches and potentiometers are only to be adjusted when the area is known to be non-hazardous.



Further Information

Proof of certification is available on request.

Also take note of the information given on the module technical information sheet.

7 Glossary

Bit	Smallest information unit. Its value can either be 1 or 0.
Bitrate	Number of bits transmitted within a time unit.
Bootstrap	Operating mode of the fieldbus Coupler. Device expects a firmware upload.
Bus	A structure used to transmit data. There are two types, serial and parallel. A serial bus transmits data bit by bit, whereas a parallel bus transmits many bits at one time.
Byte	Binary Yoked Transfer Element. A byte generally contains 8 bits.
Data bus	see <i>Bus</i> .
Fieldbus	I/O-system for serial information transmission between devices of automation technology in the process-related field area.
Hardware	Electronic, electrical and mechanic components of a module/subassembly.
Operating system	Software which links the application programs to the hardware.
Segment	Typically, a network is divided up into different physical network segments by way of <i>routers</i> or <i>repeaters</i> .
Server	Device providing services within a client/server system. The service is requested by the <i>Client</i> .
Subnet	A portion of a network that shares the same network address as the other portions. These subnets are distinguished through the subnet mask.

8 Literature list



Controller-Area-Network
Grundlagen, Protokolle, Bausteine, Anwendungen
Konrad Etschberger
2., völlig überarbeitete Auflage
2000 Carl Hanser Verlag München Wien
ISBN 3-4446-19431-2

Further information on web pages:



The ODVA provides further documentation on DeviceNet.
www.odva.org



CAN in Automation (CiA) provides further documentation on CAN.
can-cia.de

9 Index

C

carrier rail	15, 17
contacts	
data-.....	18
power-.....	24

D

data contacts	18
---------------------	----

E

Electrical isolation	32
----------------------------	----

F

Fieldbus node.....	88
--------------------	----

I

I/O modules	47
Internal bus	44

L

Light diodes	33
locking disc.....	16

P

PIO-400 [2 DI DC 24 V 3.0 ms, High-Side Switching].....	47
PIO-402 [4 DI DC 24 V 3.0 ms, High-Side Switching].....	50
PIO-430 [8 DI DC 24 V 3.0 ms, High-Side Switching].....	53
PIO-468 [4 AI DC 0-10 V, Single-Ended]	56
PIO-480 [2 AI 0-20 mA Differential Measurement Input].....	60
PIO-501 [2 DO DC 24 V 0.5 A, High-Side Switching]	64
PIO-504 [4 DO DC 24 V 0.5 A, High-Side Switching]	67
PIO-530 [8 DO DC 24 V 0.5 A, High-Side Switching]	70
PIO-550 [2 AO DC 0-10 V].....	73
PIO-552 [2 AO 0-20 mA]	77
PIO-600 [End Module].....	81
PIO-602 [24 V DC Power Supply]	83
Power contacts.....	19, 24
not carried out.....	24
Process image	46

S

Subnet.....	120
-------------	-----

U

unlocking lug	16
---------------------	----