

# Compumotor

## ZETA6104 Indexer/Drive *Installation Guide*

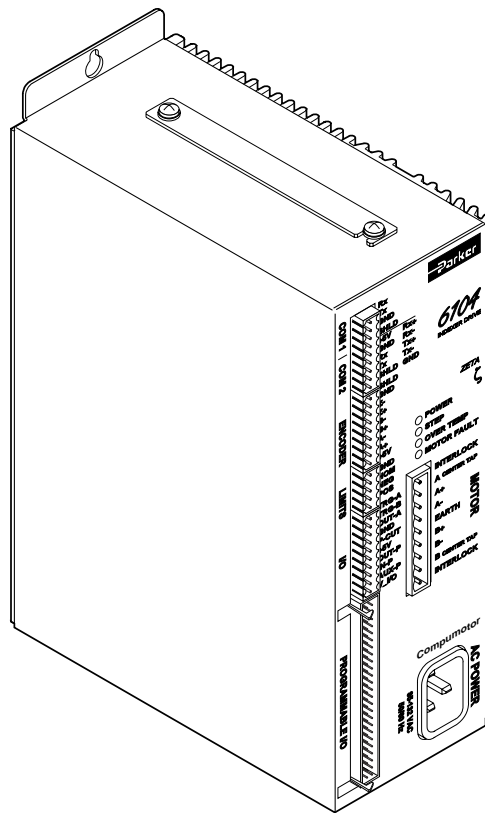

Compumotor Division  
Parker Hannifin Corporation  
p/n 88-014782-02B September 1997



# IMPORTANT

## User Information



### WARNING



6000 Series products are used to control electrical and mechanical components of motion control systems. You should test your motion system for safety under all potential conditions. Failure to do so can result in damage to equipment and/or serious injury to personnel.

6000 Series products and the information in this user guide are the proprietary property of Parker Hannifin Corporation or its licensors, and may not be copied, disclosed, or used for any purpose not expressly authorized by the owner thereof.

Since Parker Hannifin constantly strives to improve all of its products, we reserve the right to change this user guide and software and hardware mentioned therein at any time without notice.

In no event will the provider of the equipment be liable for any incidental, consequential, or special damages of any kind or nature whatsoever, including but not limited to lost profits arising from or in any way connected with the use of the equipment or this user guide.

© 1995-7, Parker Hannifin Corporation  
All Rights Reserved

Motion Architect is a registered trademark of Parker Hannifin Corporation.  
Motion Builder, CompuCAM and DDE6000 are trademarks of Parker Hannifin Corporation.  
Microsoft and MS-DOS are registered trademarks, and Windows, DDE and NetDDE are trademarks of Microsoft Corporation.  
Motion Toolbox is a trademark of Snider Consultants, Inc.  
LabVIEW is a registered trademark of National Instruments Corporation.

### Technical Assistance Contact your local automation technology center (ATC) or distributor, or ...

#### North America and Asia:

Compumotor Division of Parker Hannifin  
5500 Business Park Drive  
Rohnert Park, CA 94928  
Telephone: (800) 358-9070 or (707) 584-7558  
Fax: (707) 584-3793  
FaxBack: (800) 936-6939 or (707) 586-8586  
BBS: (707) 584-4059  
e-mail: [tech\\_help@cmotor.com](mailto:tech_help@cmotor.com)  
Internet: <http://www.compumotor.com>

#### Europe (non-German speaking):

Parker Digiplan  
21 Balena Close  
Poole, Dorset  
England BH17 7DX  
Telephone: +44 (0)1202 69 9000  
Fax: +44 (0)1202 69 5750

#### Germany, Austria, Switzerland:

HAUSER Elektronik GmbH  
Postfach: 77607-1720  
Robert-Bosch-Str. 22  
D-77656 Offenburg  
Telephone: +49 (0)781 509-0  
Fax: +49 (0)781 509-176

# Change Summary

## ZETA6104 Installation Guide

**Rev B**

September 1997

The following is a summary of the primary technical changes to this document.  
This book, p/n 88-014782-**02B**, supersedes 88-014782-**02A** and 88-014782-**01B**.

<b>Revision B Change</b>	
	Wiring diagrams (series/parallel connections) for RSxxx-xxNPS and RSxxx-xxC10 motor options have been corrected – see page 9.
<b>Revision A Changes (from 88-014782-01 B)</b>	
<b>Topic</b>	<b>Description</b>
New Hardware Revision	<p>These are the primary changes resulting from hardware enhancements:</p> <ul style="list-style-type: none"><li>• New input circuit design for P-CUT, HOM, NEG, POS, TRG-A and TRG-B. To power these inputs, you must now connect 5-24VDC (from an on-board <u>or</u> external source) to the new V_I/O terminal on the I/O connector. If V_I/O is connected to +5V, AUX-P can be connected to a supply of up to +24V; if V_I/O is connected to an external +24V supply, AUX-P must also be connected to +24V (or to GND). Switching levels depend on the power applied to V_I/O (<math>\leq 1/3</math> of V_I/O voltage = low, <math>\geq 2/3</math> of V_I/O voltage = high).</li><li>• Jumper JU7 was added to the ZETA6104 PCA. The purpose of JU7 is to select either 4-wire or 2-wire RS-485 communication. The default is 4-wire (JU7 in position 3).</li><li>• A new chip is used for the programmable output circuit (UDK2559).</li></ul>
New CE-marked OS Series and RS Series Motors	This manual has been updated with data to support the new CE-marked OS Series and RS Series motors that may be ordered with your ZETA6104 system.
Miscellaneous Corrections and Clarifications	<p><b>Corrections:</b></p> <ul style="list-style-type: none"><li>• Operating temperature range is 32-113°F (0-45°C); previously documented as 32-122°F (0-50°C).</li><li>• The ZETA6104 does <u>not</u> support RS-422 communication as noted in the previous rev.</li><li>• The Static Torque specs for the ZETA motors were incorrect. The DMTSTT (static torque) command setting for the ZETA57-83 motor should be DMTSTT2 (not DMTSTT1).</li><li>• The parallel motor wiring diagrams (see back cover and page 9) were in error and have now been corrected.</li><li>• The encoder test procedure on page 21 was corrected.</li><li>• The motor inductance requirements for non-Compumotor motors (see page 43) is: recommended range = 5.0 to 50.0 mH; minimum = 0.5 mH; maximum = 80.0 mH.</li></ul> <p><b>Clarifications:</b></p> <ul style="list-style-type: none"><li>• All inputs and outputs are optically isolated from the internal microprocessor (not from the other inputs and outputs).</li><li>• The programmable outputs (including OUT-A) will sink up to 300mA, or source up to 5mA at 5-24VDC.</li><li>• You must select <u>either</u> the on-board +5V terminal <u>or</u> an external 5-24VDC power supply to power the AUX-P, IN-P or OUT-P pull-up resistors. Connecting AUX-P, IN-P or OUT-P to the +5V terminal <u>and</u> to an external supply will <b>damage the ZETA6104</b>.</li><li>• If you are using an RS-232 connection between the host computer and the master ZETA6104 connected to multiple ZETA6104s in an RS-485 multi-drop, make sure the master ZETA6104 has these settings executed in the order given (you should place these settings in your power-up STARTP program):<ul style="list-style-type: none"><li>PORT1 (select RS-232 port, COM1, for configuration)</li><li>ECHO3 (echo to both COM ports)</li><li>PORT2 (select RS-485 port, COM2, for configuration)</li><li>ECHO2 (echo to the other COM port, COM1)</li></ul></li></ul>

Continued . . .

LVD and EMC Installation Guidelines



The ZETA6104 is in compliance with the Low Voltage Directive (72/23/EEC) and the CE Marking Directive (93/68/EEC) of the European Community.

When installed according to the procedures in the main body of this installation guide, the ZETA6104 may not necessarily comply with the Low Voltage Directive (LVD). To install the ZETA6104 so that it is LVD compliant, refer to supplemental installation instructions provided in Appendix C. If you do not follow these instructions, the protection of the ZETA6104 may be impaired.

The ZETA6104 is sold as a complex component to professional assemblers. As a component, it is not required to be compliant with Electromagnetic Compatibility Directive 89/336/EEC. However, Appendix D provides guidelines on how to install the ZETA6104 in a manner most likely to minimize the ZETA6104's emissions and to maximize the ZETA6104's immunity to externally generated electromagnetic interference.

# ABOUT THIS GUIDE

## Chapter 1. Installation

What You Should Have (ship kit) .....	2
Before You Begin .....	2
Recommended Installation Process .....	2
Electrical Noise Guidelines .....	2
General Specifications .....	3
Pre-installation Adjustments .....	4
DIP Switch Settings – Motor Current, Address, Autobaud .....	4
Changing the COM 2 Connector from RS-232 to RS-485 .....	5
Mounting the ZETA6104 .....	6
Electrical Connections .....	7
Grounding System .....	7
Pulse Cut-Off (P-CUT) — Emergency Stop Switch .....	7
Serial Communication .....	8
Motor (ZETA and OS/RS motors only) .....	9
End-of-Travel and Home Limit Inputs .....	11
Encoder .....	12
Trigger Inputs .....	13
General-Purpose Programmable Inputs & Outputs .....	14
RP240 Remote Operator Panel .....	18
Input Power .....	18
Lengthening I/O Cables .....	19
Testing the Installation .....	20
Matching the Motor to the ZETA6104 (OPTIONAL) .....	22
Mounting & Coupling the Motor .....	24
Mounting the Motor .....	24
Coupling the Motor .....	25

Optimizing System Performance (OPTIONAL) .....	26
Configuring Active Damping .....	26
Configuring Electronic Viscosity (EV) .....	29
Record Your System's Configuration .....	30
Recommended Set-up Program Elements .....	30
What's Next? .....	32
Program Your Motion Control Functions .....	32

## Chapter 2. Troubleshooting

Troubleshooting Basics .....	34
Reducing Electrical Noise .....	34
Diagnostic LEDs .....	34
Test Options .....	34
Technical Support .....	34
Common Problems & Solutions .....	35
Troubleshooting Serial Communication Problems .....	36
Product Return Procedure .....	37

<b>Appendix A</b> (Resonance, Ringing & Damping) .....	39
--	----

<b>Appendix B</b> (Using Non-Compumotor Motors) .....	43
---	----

<b>Appendix C</b> (LVD Installation Instructions) .....	47
---	----

<b>Appendix D</b> (EMC Installation Guidelines) .....	49
---	----

<b>Index</b> .....	53
--------------------	----

## Purpose of This Guide

This document is designed to help you install and troubleshoot your ZETA6104 hardware system. Programming related issues are covered in the *6000 Series Programmer's Guide* and the *6000 Series Software Reference*.

### **“ZETA6104” Synonymous with “6104”**

The ZETA6104 product is often referred to as the “6104” because it is part of the 6000 family of products. The ZETA6104's software and the 6000 Series software documentation (i.e., the Software Reference and the Programmer's Guide) refer to this product as the “6104.”

## What You Should Know

To install and troubleshoot the ZETA6104, you should have a fundamental understanding of:

- Electronics concepts, such as voltage, current, switches.
- Mechanical motion control concepts, such as inertia, torque, velocity, distance, force.
- Serial communication and terminal emulator experience: RS-232C and/or RS-485

## Related Publications

- *6000 Series Software Reference*, Parker Hannifin Corporation, Compumotor Division; part number 88-012966-01
- *6000 Series Programmer's Guide*, Parker Hannifin Corporation, Compumotor Division; part number 88-014540-01
- *Current Parker Compumotor Motion Control Catalog*
- Schram, Peter (editor). *The National Electric Code Handbook (Third Edition)*. Quincy, MA: National Fire Protection Association

## LVD Installation Guidelines



The ZETA6104 is in compliance with the Low Voltage Directive (72/23/EEC) and the CE Marking Directive (93/68/EEC) of the European Community.

When installed according to the procedures in the main body of this installation guide, the ZETA6104 may not necessarily comply with the Low Voltage Directive (LVD). To install the ZETA6104 so that it is LVD compliant, refer to supplemental installation instructions provided in Appendix C. If you do not follow these instructions, the protection of the ZETA6104 may be impaired.

The ZETA6104 is sold as a complex component to professional assemblers. As a component, it is not required to be compliant with Electromagnetic Compatibility Directive 89/336/EEC. However, Appendix D provides guidelines on how to install the ZETA6104 in a manner most likely to minimize the ZETA6104's emissions and to maximize the ZETA6104's immunity to externally generated electromagnetic interference.

CHAPTER ONE

# 1 Installation

## IN THIS CHAPTER

- Product ship kit list
- Things to consider before you install the ZETA6104
- General specifications table
- Optional pre-installation alterations
  - DIP switch settings – motor current, device address, autobaud feature
  - Changing the COM 2 port from RS-232C to RS-485
- Mounting the ZETA6104
- Connecting all electrical components (includes specifications)
- Testing the installation
- Matching the motor to the ZETA6104
- Motor mounting and coupling guidelines
- Using the damping features to optimize performance
- Preparing for what to do next



To install the ZETA6104 so that it is LVD compliant, refer to the supplemental instructions in Appendix C. Appendix D provides guidelines on how to install the ZETA6104 in a manner most likely to minimize the ZETA6104's emissions and to maximize the ZETA6104's immunity to externally generated electromagnetic interference.

# What You Should Have (ship kit)

Part Name	Part Number
ZETA6104 standard product (with ship kit).....	<b>ZETA6104</b>
<b>Ship kit:</b>	
120VAC power cord.....	44-014768-01
Motor connector .....	43-008755-01 (ZETA series motors are factory wired with a motor connector)
Wire jumpers: Qty. 3.....	44-015142-01
Qty. 1.....	44-015741-01
Quick-reference magnet (see side of ZETA6104 chassis) .....	87-014873-01
This user guide (ZETA6104 Installation Guide).....	88-014782-02
6000 Series Software Reference .....	88-012966-01
6000 Series Programmer's Guide.....	88-014540-01
Motion Architect disks: Disk 1 .....	95-013070-01
Disk 2 .....	95-013070-02
Driver & Samples.....	95-016324-01

**MOTORS:** These are the motors that can be ordered with the ZETA6104.

ZETA Motors: \*

ZETA57-51 .....Size 23 single-stack (57-51) motor  
ZETA57-83 .....Size 23 double-stack (57-83) motor  
ZETA57-102 .....Size 23 triple-stack (57-102) motor  
ZETA83-62 .....Size 34 single-stack (83-62) motor  
ZETA83-93 .....Size 34 double-stack (83-93) motor  
ZETA83-135 .....Size 34 triple-stack (83-135) motor

\* If you ordered a ZETA6104 and a ZETA motor as a "system", the product part number reflects the motor size (e.g., ZETA6104-57-83).

OS Motors (CE Marked):

OS2HB-xxx-xx.....Size 23 half-stack (57-40) motor, 170VDC winding  
OS21B-xxx-xx.....Size 23 single-stack (57-51) motor, 170VDC winding  
OS21B-xxx-xx.....Size 23 double-stack (57-83) motor, 170VDC winding

RS Motors (CE Marked):

RS31B-xxx-xx.....Size 34 single-stack (83-62) motor, 170VDC winding  
RS32B-xxx-xx.....Size 34 double-stack (83-93) motor, 170VDC winding  
RS33B-xxx-xx.....Size 34 triple-stack (83-135) motor, 170VDC winding

If an item is missing, call the factory (see phone numbers on inside front cover).

## Before You Begin



### WARNINGS



The ZETA6104 is used to control your system's electrical and mechanical components. Therefore, you should test your system for safety under all potential conditions. Failure to do so can result in damage to equipment and/or serious injury to personnel.

**Always remove power to the ZETA6104 before:**

- Connecting any electrical device (e.g., motor, encoder, inputs, outputs, etc.)
- Adjusting the DIP switches, jumpers, or other internal components

## Recommended Installation Process

This chapter is organized sequentially to best approximate a typical installation process.

1. Review the general specifications
2. Perform configuration/adjustments (if necessary)
3. Mount the ZETA6104
4. Connect all electrical system components
5. Test the installation
6. Match the motor to the ZETA6104 — *optional*
7. Mount the motor and couple the load
8. Optimize performance (using the ZETA6104's damping features) — *optional*
9. Record the system configuration (record on the information label and/or in a set-up program)
10. Program your motion control functions. Programming instructions are provided in the *6000 Series Programmer's Guide* and the *6000 Series Software Reference*. We recommend using the programming tools provided in Motion Architect for Windows (found in your ship kit). You can also benefit from an optional iconic programming interface called Motion Builder (sold separately).

## Electrical Noise Guidelines

- Do not route high-voltage wires and low-level signals in the same conduit.
- Ensure that all components are properly grounded.
- Ensure that all wiring is properly shielded.
- Noise suppression guidelines for I/O cables are provided on page 19.
- Appendix D (page 49) provides guidelines on how to install the ZETA6104 in a manner most likely to minimize the ZETA6104's emissions and to maximize the ZETA6104's immunity to externally generated electromagnetic interference.



# General Specifications

Parameter	Specification
<b>Power</b>	
AC input.....	95-132VAC, 50/60Hz, single-phase (refer to page 18 for peak power requirements, based on the motor you are using)
Status LEDs/fault detection.....	Refer to Diagnostic LEDs on page 34
<b>Environmental</b>	
Operating Temperature .....	32 to 113°F (0 to 45°C) — over-temperature shutdown fault at 131°F (55°C)
Storage Temperature.....	-22 to 185°F (-30 to 85°C)
Humidity .....	0 to 95% non-condensing
<b>Performance</b>	
Position Range & Stepping Accuracy .....	Position range: ±2,147,483,648 steps; Stepping accuracy: ±0 steps from preset total
Velocity Range, Accuracy, & Repeatability.....	Range: 1-2,000,000 steps/sec; Accuracy: ±0.02% of maximum rate; Repeatability: ±0.02% of set rate
Acceleration Range.....	1-24,999,975 steps/sec <sup>2</sup>
Motion Algorithm Update Rate.....	2 ms
<b>Serial Communication</b>	
Connection Options.....	RS-485 requires internal jumper and DIP switch configuration (see page 5). RS-232C, 3-wire; RS-485 (default is 4-wire; for 2-wire move JU7 to position 1); Change internal jumpers JU1-JU6 to position 1 to select RS-485 communication
Maximum units in daisy-chain or multi-drop.....	99 (use DIP switch or ADDR command to set individual addresses for each unit)
Communication Parameters.....	9600 baud (range is 19200-1200—see AutoBaud, page 4), 8 data bits, 1 stop bit, no parity; RS-232: Full duplex; RS-485: Half duplex (change jumper JU6 to position 1)
<b>Inputs</b>	
All inputs are optically isolated from the microprocessor (not from the other inputs).	
HOM, POS, NEG, TRG-A, TRG-B, P-CUT .....	Powered by voltage applied to <b>V_I/O</b> terminal (switching levels: ≤1/3 of <b>V_I/O</b> voltage = low, ≥2/3 of <b>V_I/O</b> voltage = high). <b>V_I/O</b> can handle 5-24V with max. current of 100mA. Internal 6.8 KΩ pull-ups to <b>AUX-P</b> terminal—connect <b>AUX-P</b> to power source (+5V terminal or an external 5-24V supply) to source current or connect <b>AUX-P</b> to <b>GND</b> to sink current; <b>AUX-P</b> can handle 0-24V with max. current of 50mA. Voltage range for these inputs is 0-24V.
Encoder.....	Differential comparator accepts two-phase quadrature incremental encoders with differential (recommended) or single-ended outputs. Maximum voltage = 5VDC. Switching levels (TTL-compatible): Low ≤ 0.4V, High ≥ 2.4V. Maximum frequency = 1.6 MHz. Minimum time between transitions = 625 ns.
16 General-Purpose Programmable .....	HCMOS compatible* with internal 6.8 KΩ pull-ups to <b>IN-P</b> terminal—connect <b>IN-P</b> to power source (+5V pin #49 or an external 5-24V supply) to source current or connect <b>IN-P</b> to <b>GND</b> to sink current; <b>IN-P</b> can handle 0-24V with max. current of 100 mA. Voltage range = 0-24V.
<b>Outputs</b>	
All outputs are optically isolated from the microprocessor (not from the other outputs).	
9 Programmable (includes <b>OUT-A</b> ).....	Open collector output with 4.7 KΩ pull-ups. Can be pulled up by connecting <b>OUT-P</b> to power source (+5V terminal or an external 5-24V supply); <b>OUT-P</b> can handle 0-24V with max. current of 50mA. Outputs will sink up to 300mA or source up to 5mA at 5-24VDC. 8 general-purpose outputs on the <b>Programmable I/O</b> connector, <b>OUT-A</b> on the <b>I/O</b> connector.
+5V Output.....	Internally supplied +5VDC. +5V terminals are available on the <b>COM2</b> , <b>ENCODER</b> and <b>I/O</b> connectors. Load limit (total load for all I/O connections) is 0.5A.

\* HCMOS-compatible switching voltage levels: Low ≤ 1.00V, High ≥ 3.25V.  
TTL-compatible switching voltage levels: Low ≤ 0.4V, High ≥ 2.4V.

Motor Specifications		Size 23 ZETA Motors			Size 34 ZETA Motors			Size 23 OS Motors			Size 34 RS Motors		
		ZETA 57-51	ZETA 57-83	ZETA 57-102	ZETA 83-62	ZETA 83-93	ZETA 83-135	OS2HB	OS21B	OS22B	RS31B	RS32B	RS33B
<b>Static Torque</b>	oz-in (N-m)	65 (0.46)	125 (0.88)	148 (1.05)	141 (1.00)	292 (2.11)	382 (2.70)	43 (0.30)	82 (0.58)	155 (1.09)	141 (1.00)	292 (2.06)	382 (2.70)
<b>Rotor Inertia</b>	oz-in <sup>2</sup> (kg-m <sup>2</sup> x 10 <sup>-6</sup> )	0.546 (9.998)	1.1 (20.1)	1.69 (30.9)	3.47 (63.4)	6.76 (124)	10.47 (191)	0.386 (0.070)	0.656 (0.119)	1.390 (0.253)	3.204 (0.583)	6.563 (1.195)	9.652 (1.757)
<b>Bearings</b>													
Thrust load	lb (kg)	25 (11.3)	25 (11.3)	25 (11.3)	50 (22.6)	50 (22.6)	50 (22.6)	13 (5.9)	13 (5.9)	13 (5.9)	180 (81.6)	180 (81.6)	180 (81.6)
Radial load	lb (kg)	15 (6.8)	15 (6.8)	15 (6.8)	25 (11.3)	25 (11.3)	25 (11.3)	20 (9.1)	20 (9.1)	20 (9.1)	35 (15.9)	35 (15.9)	35 (15.9)
End play (Reversing load equal to 1 lb)	in (mm)	0.005 (0.13)	0.005 (0.13)	0.005 (0.13)	0.005 (0.13)	0.005 (0.13)	0.005 (0.13)	0.001 (0.025)	0.001 (0.025)	0.001 (0.025)	0.001 (0.025)	0.001 (0.025)	0.001 (0.025)
Radial play (Per 0.5 lb load)	in (mm)	0.0008 (0.02)	0.0008 (0.02)	0.0008 (0.02)	0.0008 (0.02)	0.0008 (0.02)	0.0008 (0.02)	0.0008 (0.02)	0.0008 (0.02)	0.0008 (0.02)	0.0008 (0.02)	0.0008 (0.02)	0.0008 (0.02)
<b>Weight</b>	lb (Motor+Cable+Connector) (kg)	1.6 (0.7)	2.4 (1.1)	3.2 (1.5)	3.8 (1.7)	5.1 (2.3)	8.3 (3.8)	1.0 (0.45)	1.5 (0.68)	2.5 (1.14)	3.2 (1.45)	5.3 (2.41)	7.6 (3.45)
<b>Certifications</b>	UL Rec. CE (LVD) CE (LVD & EMC)	No No No	No No No	No No No	No No No	No No No	No No No	No Yes No	No Yes No	No Yes No	Yes Yes	Yes Yes	Yes Yes
<b>Speed/Torque Curves</b>		----- Refer to page 10 -----			----- Refer to page 10 -----			----- Refer to page 10 -----			----- Refer to page 10 -----		
<b>Dimensions</b>		----- Refer to page 24 -----			----- Refer to page 24 -----			----- Refer to page 24 -----			----- Refer to page 24 -----		

# Pre-installation Adjustments

## Factory Settings May Be Sufficient (if so, skip this section):

- Device address is set to zero (if daisy-chaining you can automatically establish with the ADDR command).
- Serial communication method is RS-232C.

## DIP Switch Settings – Motor Current, Address, Autobaud

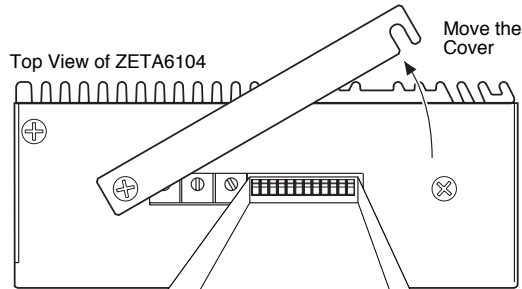

**CAUTION**  
Do not set switches 6-11 to ON at the same time. This invokes a factory test mode in which the ZETA6104 executes a motion sequence upon power up.



Motor Current (Amps)	1	2	3	4	5	6	7	8	9	10	11	12	Address
0.14	off	off	off	off	off	off	off	off	off	off	off	off	0 (default)
0.26	off	off	off	off	off	on	off	off	off	off	off	off	1
0.39	off	off	off	off	on	off	off	off	off	off	off	off	2
0.51	off	off	off	on	off	off	off	off	off	off	off	off	3
0.64	off	off	on	off	off	off	off	off	off	off	off	off	4
0.76	off	off	on	off	on	off	off	off	off	off	off	off	5
0.89	off	off	on	on	off	off	off	off	off	off	off	off	6
1.01	off	off	on	on	on	off	off	off	off	off	off	off	7
1.14	off	on	off	off	off	off	off	off	off	off	off	off	8
Zeta57-51 Series	1.26	off	on	off	off	on	off	off	off	off	off	off	9
Zeta57-83 Series	1.38	off	on	off	on	off	off	off	off	off	off	off	10
OS2HB Series	1.51	off	on	off	on	off	off	off	off	off	off	off	11
Zeta57-102 Series	1.63	off	on	on	off	off	off	off	off	off	off	off	12
OS21B Series	1.76	off	on	on	off	on	off	off	off	off	off	off	13
OS21B Series	1.88	off	on	on	on	off	off	off	off	off	off	off	14
OS22B Series	2.01	off	on	on	on	on	off	off	off	off	off	off	15
Zeta83-62 Series	2.14	on	off	off	off	off	off	off	off	off	off	off	16
Zeta83-62 Series	2.26	on	off	off	off	off	on	off	off	off	off	off	17
RS31B Series	2.38	on	off	off	on	off	off	off	off	off	off	off	18
Zeta57-51 Parallel	2.51	on	off	off	on	off	off	off	off	off	off	off	19
Zeta83-93 Series	2.63	on	off	on	off	off	off	off	off	off	off	off	20
RS32B Series	2.76	on	off	on	on	off	off	off	off	off	off	off	21
OS2HB Parallel	2.88	on	off	on	on	off	off	off	off	off	off	off	22
Zeta57-83 Parallel	3.01	on	on	off	off	off	off	off	off	off	off	off	23
Zeta57-102 Parallel	3.13	on	on	off	off	off	off	off	off	off	off	off	24
Zeta57-102 Parallel	3.26	on	on	off	off	on	off	off	off	off	off	off	25
Zeta83-135 Series	3.38	on	on	off	on	off	off	off	off	off	off	off	26
RS33B Series	3.50	on	on	off	on	on	off	off	off	off	off	off	27
OS21B Parallel	3.63	on	on	on	off	off	off	off	off	off	off	off	28
Zeta83-xxx Parallel	3.75	on	on	on	on	off	off	off	off	off	off	off	29
OS22B Parallel	3.88	on	on	on	on	off	off	off	off	off	off	off	30
RS3xB Parallel	4.00	on	on	on	on	on	off	off	off	off	off	off	31

**Factory Settings:** If you ordered a ZETA Series motor as part of your ZETA6104 "system" (e.g., ZETA6104-83-62), then the DIP switches will be factory-configured to operate your specific motor in a series wiring configuration.

If you ordered the ZETA6104 without a motor, or with an OS or RS Series motor, or if you ordered the ZETA Series motor separately (not as a "system"), all DIP switches are factory-set to the OFF position.

### AutoBaud

The default baud rate is 9600. As an alternative, you can use this procedure to automatically match your terminal's speed of 1200, 2400, 4800, 9600, or 19200 baud.

1. Set switch 6 to on and switch 7 to off.
2. Connect the ZETA6104 to the terminal.
3. Power up the terminal.
4. Cycle power to the ZETA6104 and immediately press the space bar several times.
5. The ZETA6104 should send a message with the baud rate on the first line of the response. If no baud rate message is displayed, verify steps 1-3 and repeat step 4.
6. Change switches 6 & 7 to off.
7. Cycle power to the ZETA6104. This stores the baud rate in non-volatile memory.

**NOTE:** Autobaud works only on the ZETA6104's COM 1 serial port.

# Changing the COM 2 Connector from RS-232 to RS-485



COM 2

- +5V
- GND
- Rx
- Tx
- SHLD

- Rx+
- Rx-
- Tx+
- Tx-
- GND

RS-485 (optional)  
RS-232 (factory default)

### RS-232C Users

The ZETA6104's **COM 2** port is factory configured for RS-232C communication (use the left-hand pin descriptions). If you do not need to use RS-485 communication, you may ignore this section and proceed to the Mounting instructions.

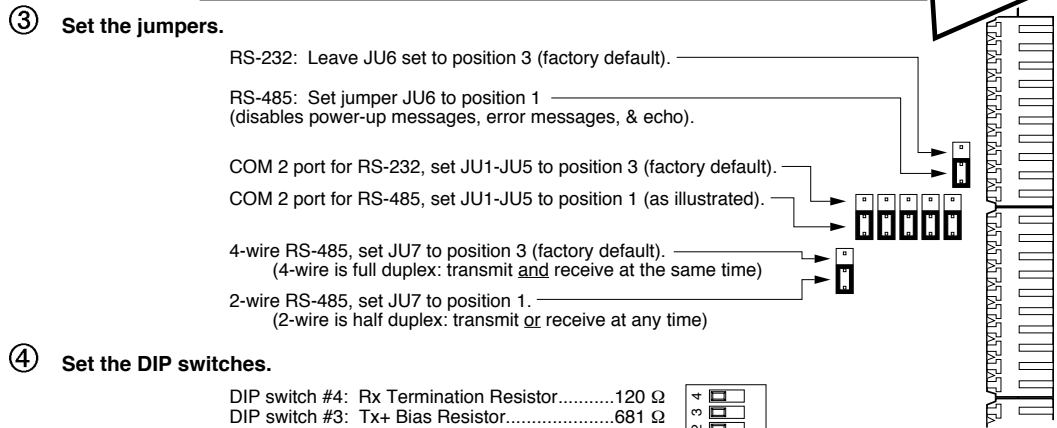
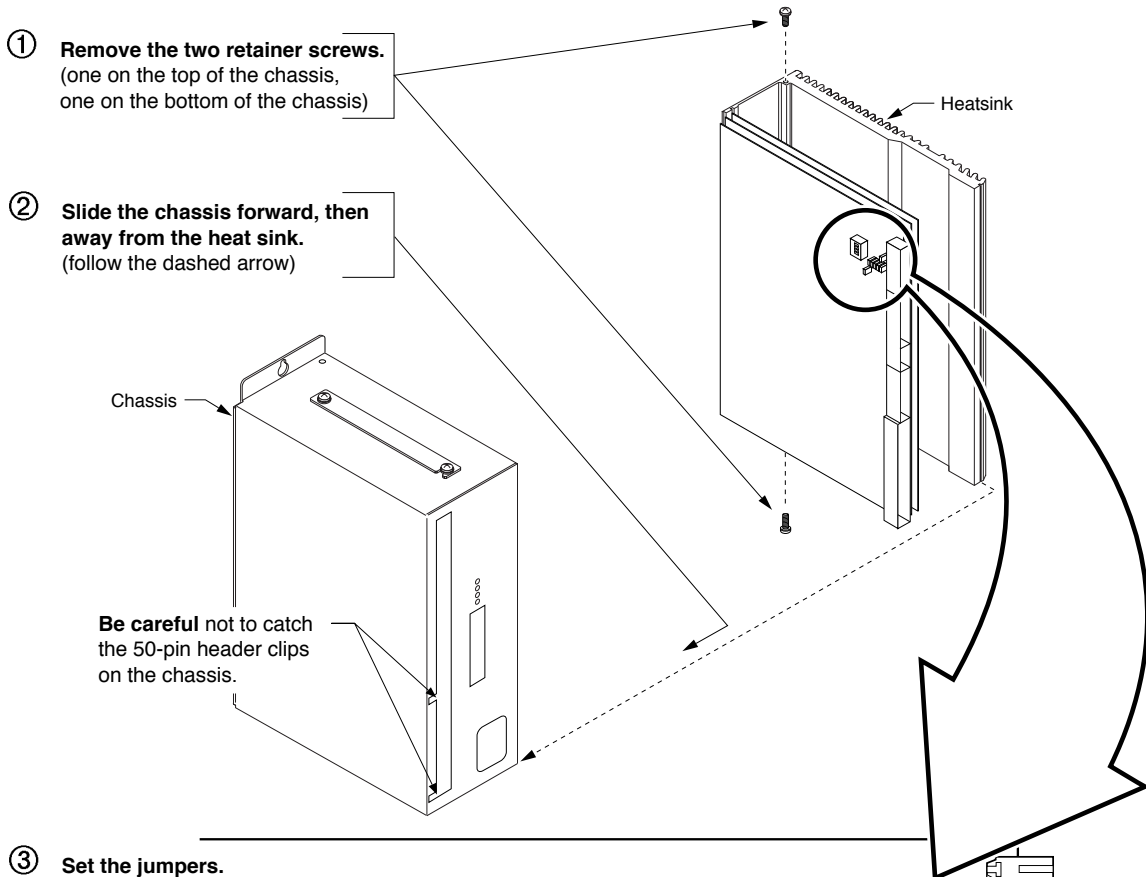

**NOTE:** Set the switches to ON (as illustrated) to use the internal resistors. Do this for a single unit or for the last unit in a multi-drop only. If these resistor values are not appropriate for your application, set the switches to OFF and connect your own external resistors. See page 8 for resistor calculations and wiring instructions.

⑤ **Reattach the chassis and replace the two retainer screws.**

# Mounting the ZETA6104

## Before you mount the ZETA6104

Check the list below to make sure you have performed all the necessary configuration tasks that require accessing internal components (DIP switches, potentiometers, and jumpers). You may, however, be able to adjust DIP switches and pots after mounting, if you allow access to the top of the ZETA6104 chassis.

- **Select motor current (DIP switches).** If you ordered a ZETA motor with your system (e.g., ZETA6104-57-83) and you intend to use series motor winding, use the factory setting. If you need to change this setting, refer to page 4 for instructions.
- **Select device address (DIP switches).** If you are not connecting multiple ZETA6104 units in an RS-232C daisy chain or an RS-485 multi-drop, use the factory setting. If you need to change this setting, refer to page 4 for instructions.
- **Select serial communication method (jumpers & DIP switches).** If you are using RS-232C to communicate with the ZETA6104, use the factory settings. If you need to change these settings (i.e., for RS-485), refer to page 5 for instructions.
- Be aware that if you exercise the motor matching procedures on page 22, you will need to access the potentiometers at the top of the ZETA6104 chassis. (The motor matching procedures are placed after the Electrical Connections section of this manual because the process requires that you first understand how to connect the motor, serial communication, and AC power.)

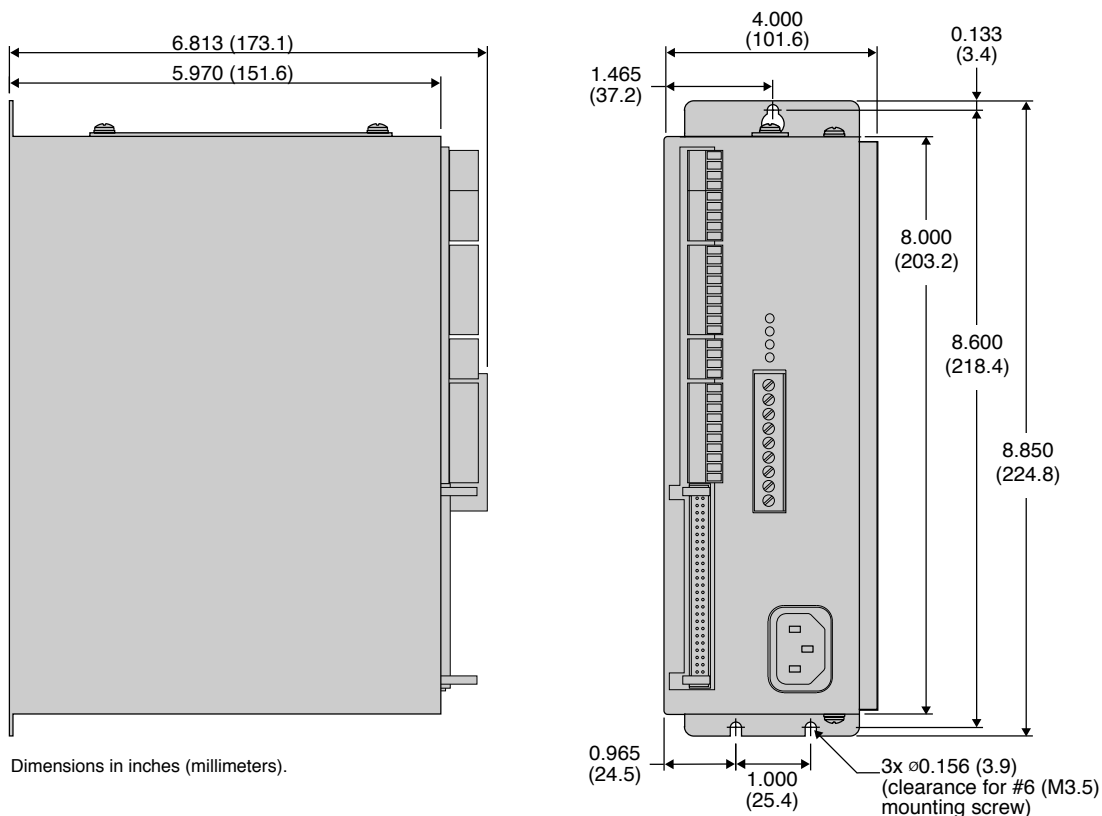

## Environmental Considerations

**Temperature.** Operate the ZETA6104 in ambient temperatures between 32°F (0°C) and 113°F (45°C). Provide a minimum of 1 inch (25.4 mm) of unrestricted air-flow space around the ZETA6104 chassis (see illustration). The ZETA6104 will shut itself down if its internal sensor reaches 131°F (55°C).

**Humidity.** Keep below 95%, non-condensing.

**Airborne Contaminants, Liquids.** Particulate contaminants, especially electrically conductive material, such as metal shavings and grinding dust, can damage the ZETA6104 and the Zeta motor. Do not allow liquids or fluids to come in contact with the ZETA6104 or its cables.

### Minimum Airflow Space = 1 inch

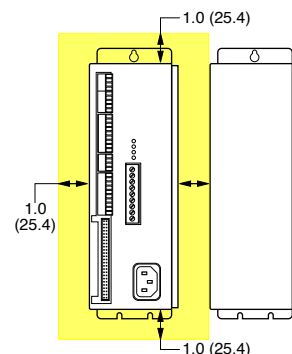

# Electrical Connections



To install the ZETA6104 so that it is LVD compliant, refer also to the supplemental instructions in Appendix C. Appendix D provides guidelines on how to install the ZETA6104 in a manner most likely to minimize the ZETA6104's emissions and to maximize the ZETA6104's immunity to externally generated electromagnetic interference.

## Grounding System

\* The function of COM2's terminals depends on whether it is configured for RS-232 (the factory default configuration) or for RS-485 (see page 5 for configuration).

**NOTE:** The inputs and outputs are isolated from the internal microprocessor, but are not isolated from the other inputs and outputs.

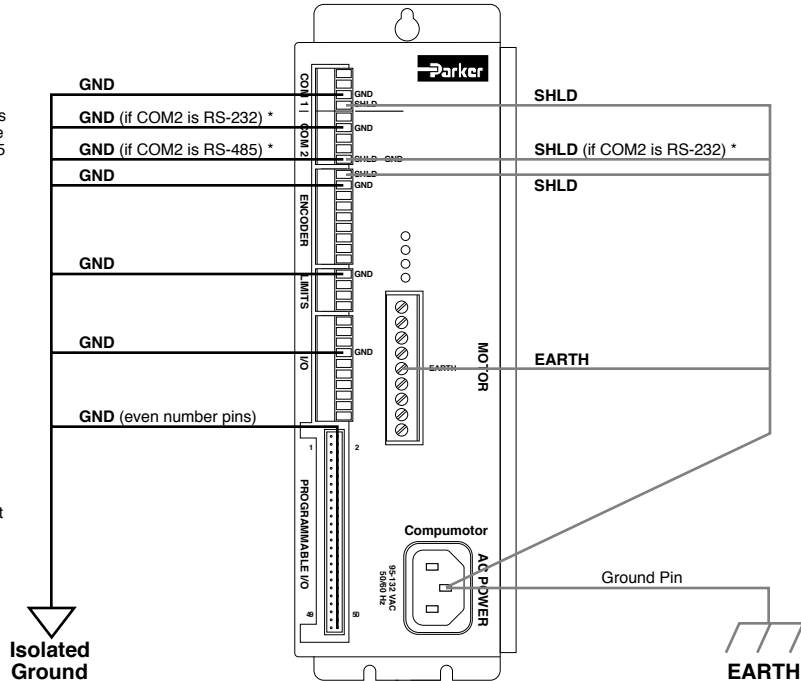

## Pulse Cut-Off (P-CUT) — Emergency Stop Switch

**P-CUT connected to GND (normally-closed switch).**  
If this connection is opened, motion is killed and the program in progress is terminated.

If the P-CUT input is not grounded when motion is commanded, motion will not occur and the error message "WARNING: PULSE CUTOFF ACTIVE" will be displayed in the terminal emulator.

**+5V connected to AUX-P and V\_I/O (sourcing current).**  
Provides +5V power to the P-CUT pull-up resistor. As an alternative, you can connect AUX-P to an external supply of up to +24V (but do not use both the on-board +5V terminal and an external 5-24V supply). If V\_I/O is connected to a +5V supply (on-board or external), AUX-P can be connected to a supply of up to +24V. If V\_I/O is connected to an external +24V supply, AUX-P must also be connected to +24V (or to GND).

Switching levels depend on the voltage applied to V\_I/O:  
LOW  $\leq 1/3$  of V\_I/O voltage; HIGH  $\geq 2/3$  of V\_I/O voltage

**NOTE:** AUX-P and V\_I/O are also used by the HOM, NEG, POS & TRG inputs.

**SINKING CURRENT:** To make P-CUT (as well as HOM, NEG, POS & TRG) sink current, connect AUX-P to GND.

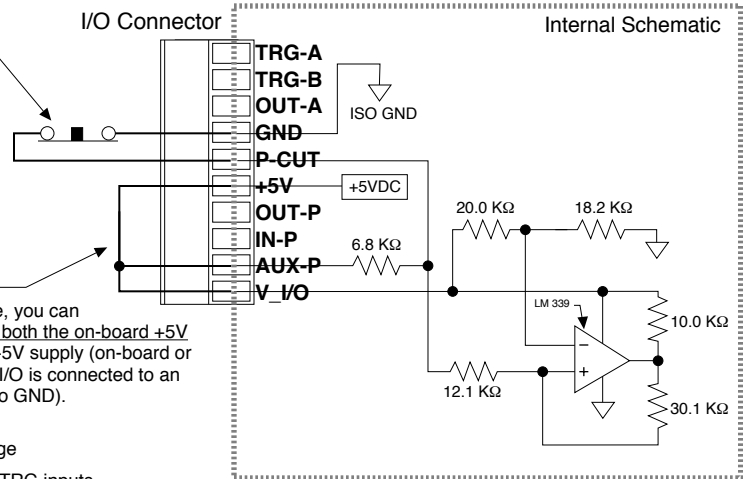

**CAUTION:** You must select either the on-board +5V terminal or an external power supply to power the AUX-P pull-up resistor (for the P-CUT, HOM, NEG, POS, TRG-A, and TRG-B inputs). Connecting AUX-P to the +5V terminal and an external supply will **damage the ZETA6104**. (The same rule applies to the IN-P and OUT-P terminals, see page 14.)

# Serial Communication

## RS-232C Connections

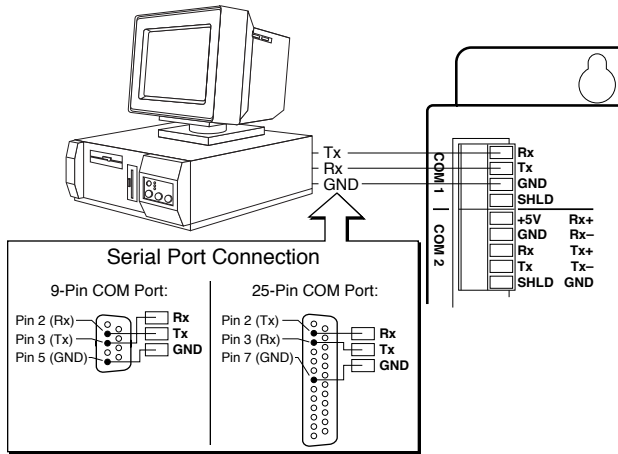

**NOTE:** Maximum RS-232C cable length is 50 feet (15.25 meters)

## RS-232C Daisy-Chain Connections\*

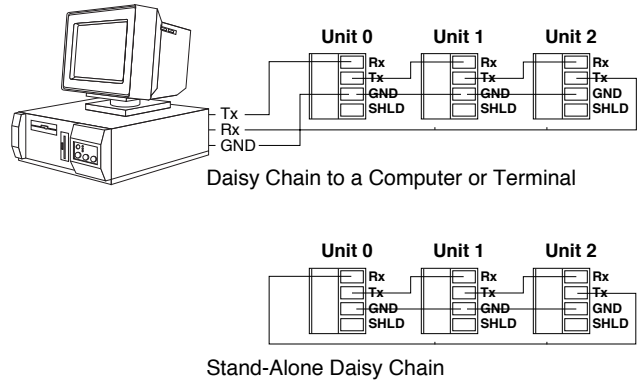

\* Be sure to set unique devices addresses for each unit. To set the address, use the DIP switch (see page 4), or use the ADDR command (see 6000 Series Programmer's Guide).

## RS-485 Connections (4-wire interface, plus ground)

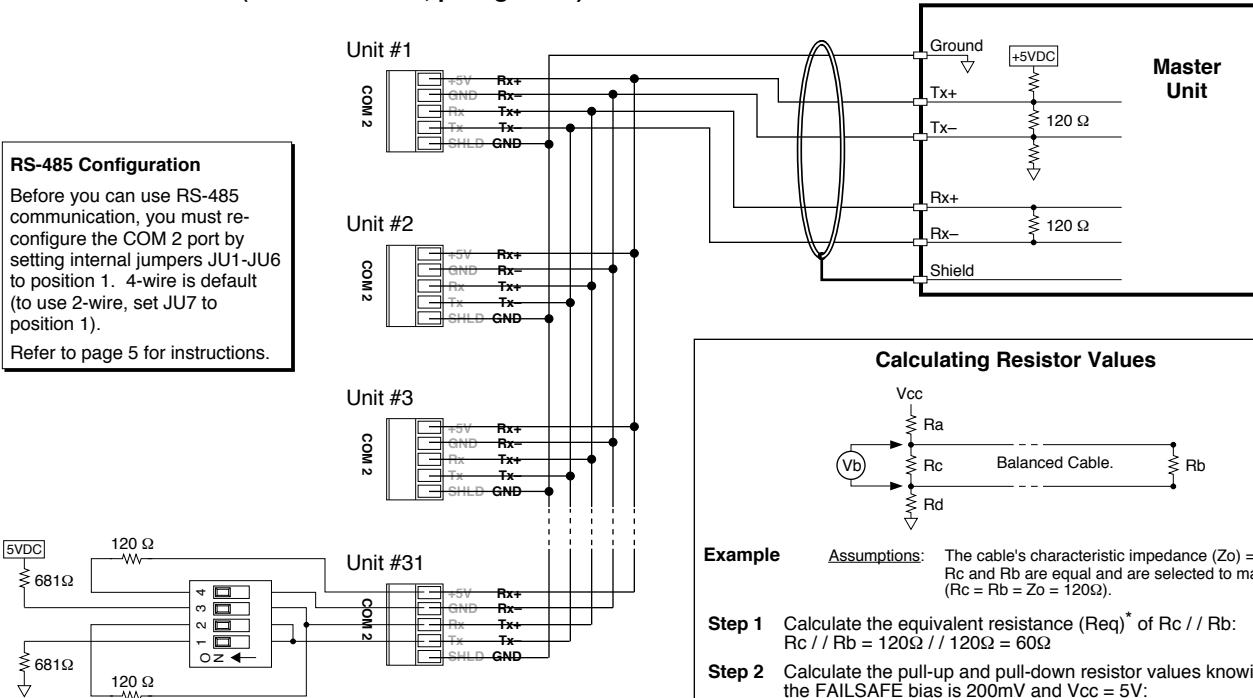

**RS-485 Configuration**  
 Before you can use RS-485 communication, you must re-configure the COM 2 port by setting internal jumpers JU1-JU6 to position 1. 4-wire is default (to use 2-wire, set JU7 to position 1). Refer to page 5 for instructions.

DIP switch selects internal resistor values (ON selects the resistor). Use these resistors only for the last unit (or for a single unit). If your application requires terminating resistors other than 120Ω, and/or bias resistors other than 681Ω, then make sure the internal DIP switches are set to OFF and connect your own external resistors. To calculate resistor values:

**NOTE:** Maximum RS-485 cable length is 4000 feet (1220 meters)

**Calculating Resistor Values**

**Example Assumptions:** The cable's characteristic impedance ( $Z_0$ ) = 120Ω.  $R_c$  and  $R_b$  are equal and are selected to match  $Z_0$  ( $R_c = R_b = Z_0 = 120\Omega$ ).

**Step 1** Calculate the equivalent resistance ( $R_{eq}$ )\* of  $R_c // R_b$ :  
 $R_c // R_b = 120\Omega // 120\Omega = 60\Omega$

**Step 2** Calculate the pull-up and pull-down resistor values knowing that the FAILSAFE bias is 200mV and  $V_{cc} = 5V$ :  
 $V_b = V_{cc} (R_{eq} / (R_a + R_{eq} + R_d))$   
 solving for  $R'$  (defined as  $R_a + R_d$ )  
 $R' = ((R_{eq} V_{cc} / V_b) - R_{eq})$   
 $R' = ((60\Omega) 5V / 0.2V) - 60\Omega = 1440\Omega$   
 Since  $R_a$  and  $R_d$  are equal,  $R_a = R_d = 1440\Omega / 2 = 720\Omega$

**Step 3** Recalculate the equivalent resistance of  $R_c // (R_a + R_d)$ :  
 $R_c // (R_a + R_d) = 120\Omega // (720\Omega + 720\Omega) = 110.77\Omega$

Since the equivalent resistance is close (within 10%) to the characteristic impedance of the cable ( $Z_0$ ), no further adjustment of resistor values is required.

\* Actual calculation for equivalent resistance (e.g.,  $R_1 // R_2$ ):  $\frac{R_1 R_2}{(R_1 + R_2)}$

For further information, consult a communications interface reference.

# Motor (ZETA and OS/RS motors only)

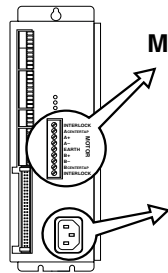

**Motor Connector**

**WARNING:** Remove AC power before connecting or disconnecting the motor. Lethal voltages are present on the screw terminals

**ZETA, OS and RS Motors**  
 Specifications – see page 3.  
 Speed/Torque curves – see page 10.  
 Considerations for series & parallel wiring – see page 10.  
 Current settings – see page 4. Dimensions – see page 24.  
 Cable extension – see table below.  
 ZETA & RSxxx-xxC10 motors include a rubber boot for safety.

**Non-Compumotor Motors**  
 If you intend to use a non-Compumotor motor, refer to Appendix B for connection instructions and current selection.

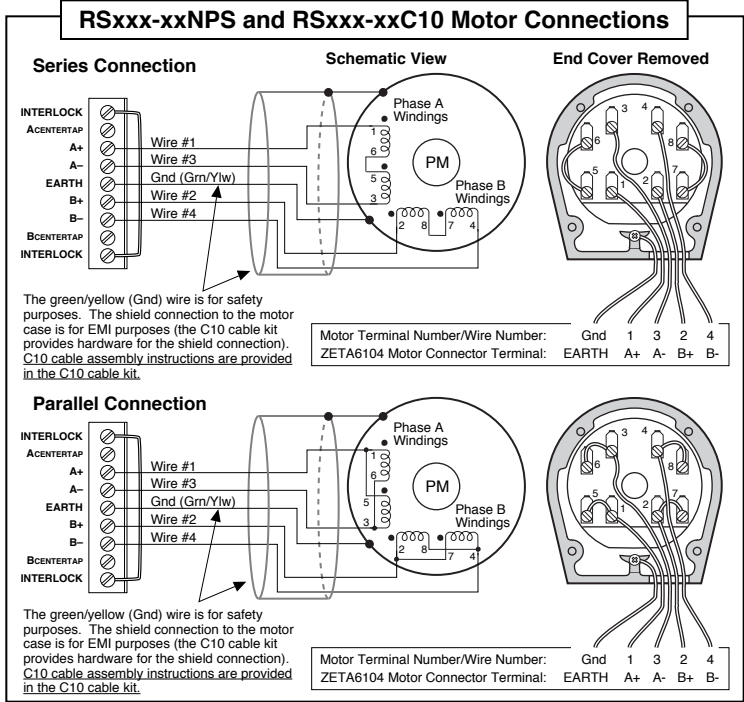
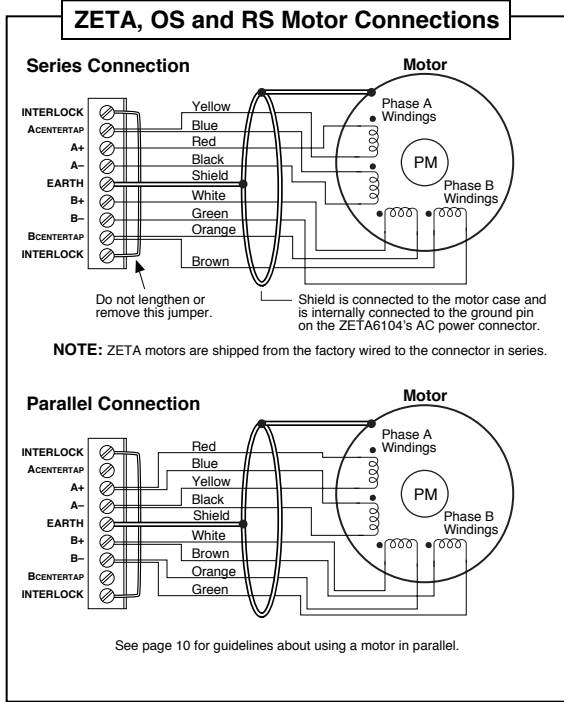

**Auto Current Standby Mode:** Reduces motor current by 50% when step pulses from the ZETA6104 have stopped for one second (**CAUTION:** torque is also reduced). Full current is restored upon the first step pulse. Enable with the DAUTOS1 command; disable with the DAUTOS0 command (default is disabled). For more information, refer to the DAUTOS command in the 6000 Series Software Reference.

### Extending ZETA Motor Cables

Standard length is 10 ft (3 m); maximum extended length is 200 ft (61 m).

**CAUTION:** Cables longer than 50 feet (15 m) may degrade performance.

Motor Type	Max. Current (amps)	< 100 ft (30 m)		100-200 ft (30-60 m)	
		AWG	mm <sup>2</sup>	AWG	mm <sup>2</sup>
ZETA57-51(S)	1.26	22	0.34	20	0.50
ZETA57-51(P)	2.38	22	0.34	20	0.50
ZETA57-83(S)	1.51	22	0.34	20	0.50
ZETA57-83(P)	3.13	22	0.34	20	0.50
ZETA57-102(S)	1.76	22	0.34	20	0.50
ZETA57-102(P)	3.50	20	0.50	18	0.75
ZETA83-62(S)	2.26	22	0.34	20	0.50
ZETA83-62(P)	4.00	20	0.50	18	0.75
ZETA83-93(S)	2.88	22	0.34	20	0.50
ZETA83-93(P)	4.00	20	0.50	18	0.75
ZETA83-135(S)	3.50	20	0.50	18	0.75
ZETA83-135(P)	4.00	20	0.50	18	0.75

### Extending OS and RS Motor Cables

-L10, -R10 & -C10 motors are shipped with 10 ft (3 m) cables;  
 -FLY motor is shipped with 1 ft (0.3 m) flying leads.  
 -NPS motor does not include cable/leads; 10-foot: use 18 AWG (0.75 mm<sup>2</sup>) wire.  
**LVD COMPLIANCE:** Maximum DC resistance between the ZETA6104's "EARTH" terminal ("protective conductor terminal") and motor body must not exceed 0.1 Ω. (This criteria must be taken into consideration when sizing cross-section (gauge) for extended cable lengths.)  
**NON-LVD:** Maximum extended length is 200 ft (61 m), but cables longer than 50 feet (15 m) may degrade performance. See table below for guidelines:

Motor Type	Max. Current (amps)	< 100 ft (30 m)		100-200 ft (30-60 m)	
		AWG	mm <sup>2</sup>	AWG	mm <sup>2</sup>
OS2HB(S)	1.51	22	0.34	20	0.50
OS2HB(P)	3.01	22	0.34	20	0.50
OS21B(S)	1.88	22	0.34	20	0.50
OS21B(P)	3.75	20	0.50	18	0.75
OS22B(S)	2.14	22	0.34	20	0.50
OS22B(P)	4.00	20	0.50	18	0.75
RS31B(S)	2.26	22	0.34	20	0.50
RS31B(P)	4.00	20	0.50	18	0.75
ZETA83-93(S)	2.88	22	0.34	20	0.50
ZETA83-93(P)	4.00	20	0.50	18	0.75
ZETA83-135(S)	3.50	20	0.50	18	0.75
ZETA83-135(P)	4.00	20	0.50	18	0.75

(S) = Series Configuration (P) = Parallel Configuration

**NOTE:** Rated current in wire sizes shown may result in a maximum temperature rise of 18°F (10°C) above ambient.

## Selecting Series or Parallel Motor Wiring

### Zeta Motor Curves

— = Torque  
 ..... = Power

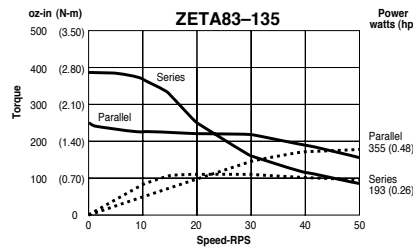
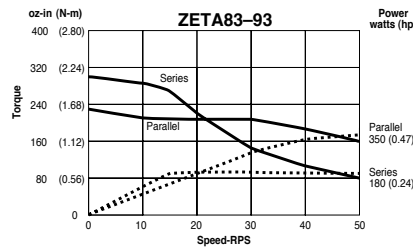
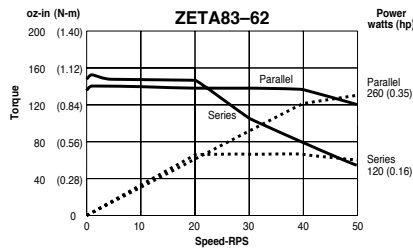
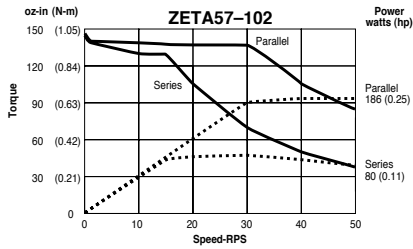
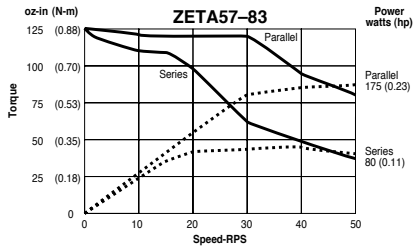
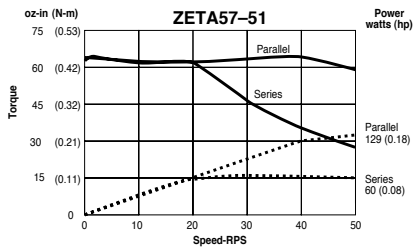

### O & R Motor Curves

— = Torque  
 ..... = Power

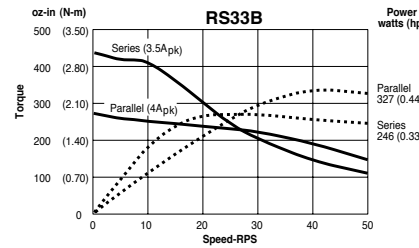
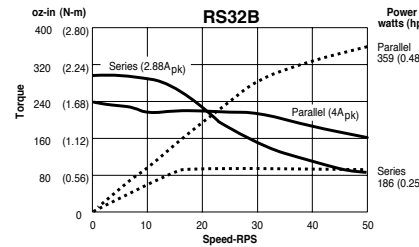
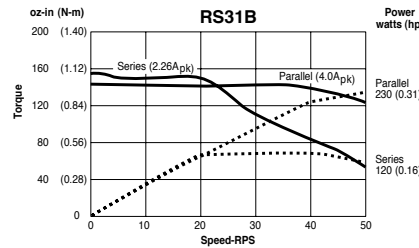
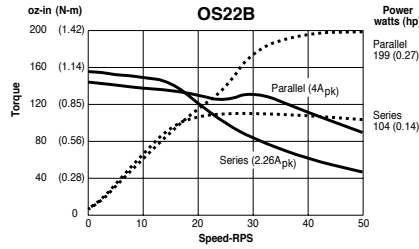
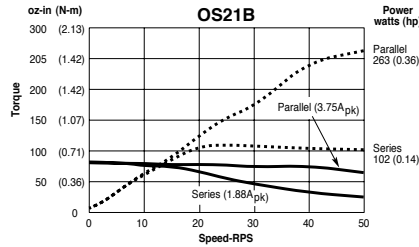
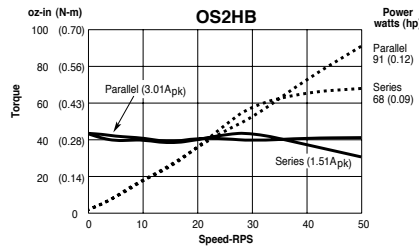

**Use series wiring if your application permits.**

ZETA motors come from the factory with a permanently attached motor cable wired to the motor connector for series motor current. The O and R Series motors have flying leads or pigtailed that you must wire to the motor connector yourself. The operating temperature of a motor connected in series will be lower than that of a motor connected in parallel. Typically, series connections work well in high torque/low speed applications.

Series motor wiring diagrams are provided on page 9.

**When to use parallel wiring.**

At higher speeds, a motor connected in parallel will produce more torque than the same motor connected in series. Use **caution**, however, because the operating temperature of the motor in parallel will be much hotter. If you operate your motor in parallel, measure motor temperature under actual operating conditions. If the motor exceeds its maximum case temperature, reduce the duty cycle to limit motor heating. Compumotor-supplied motors have maximum case temperatures of 212°F (100°C).

To wire the motor for parallel motor current, refer to the wiring diagrams on page 9.

**Non-Compumotor Motors:**

If you are using a non-Compumotor motor, refer to Appendix B for connection instructions and current-select DIP switch settings.



# End-of-Travel and Home Limit Inputs

- NOTES**
- **CAUTION:** Use either the on-board +5V terminal or an external power supply to power the **AUX-P** pull-up resistor (using both will damage the ZETA6104).
  - Motion will not occur until you do one of the following:
    - Install end-of-travel (**POS & NEG**) limit switches.
    - Disable the limits with the **LH0** command (recommended only if load is not coupled).
    - Change the active level of the limits with the **LHLVL** command.
  - Refer to the Basic Operation Setup chapter in the 6000 Series Programmer's Guide for in-depth discussions about using end-of-travel limits and homing.

## CONNECTIONS & INTERNAL SCHEMATICS

**HOM connected to GND (normally-open switch).**  
 The home limit input is used during a homing move, which is initiated with the **HOM** command. After initiating the homing move, the controller waits for the home switch to close, indicating that the load has reached the "home" reference position. The active level (default is active low) can be changed with the **HOMLVL** command. You can also use an encoder's Z channel pulse, in conjunction with the home switch, to determine the home position (this feature is enabled with the **HOMZ1** command).

**POS & NEG connected to GND (normally-closed switches).**  
 Mount each switch such that the load forces it to open before it reaches the physical travel limit (leave enough room for the load to stop). When the load opens the switch, the axis stops at the decel value set with the **LHAD** command. The motor will not be able to move in that same direction until you execute a move in the opposite direction and clear the limit by closing the switch (or you can disable the limits with the **LH0** command, but this is recommended only if the motor is not coupled to the load). The active level (default is active low) can be changed with the **LHLVL** command.

**+5V connected to AUX-P and V\_I/O (sourcing current).**  
 Provides +5V power to the POS, NEG, and HOM input pull-up resistors. As an alternative, you can connect AUX-P to an external supply of up to +24V (but do not use both the on-board +5V terminal and an external 5-24V supply). If V\_I/O is connected to a +5V supply (on-board or external), AUX-P can be connected to a supply of up to +24V. If V\_I/O is connected to an external +24V supply, AUX-P must also be connected to +24V (or to GND).

Switching levels depend on voltage at V\_I/O (LOW ≤ 1/3 of V\_I/O volts; HIGH ≥ 2/3 of V\_I/O volts).

**NOTE:** AUX-P and V\_I/O are also used by the P-CUT & TRG inputs.

**SINKING CURRENT:** To make the limit inputs (as well as P-CUT & TRG) sink current, connect AUX-P to GND.

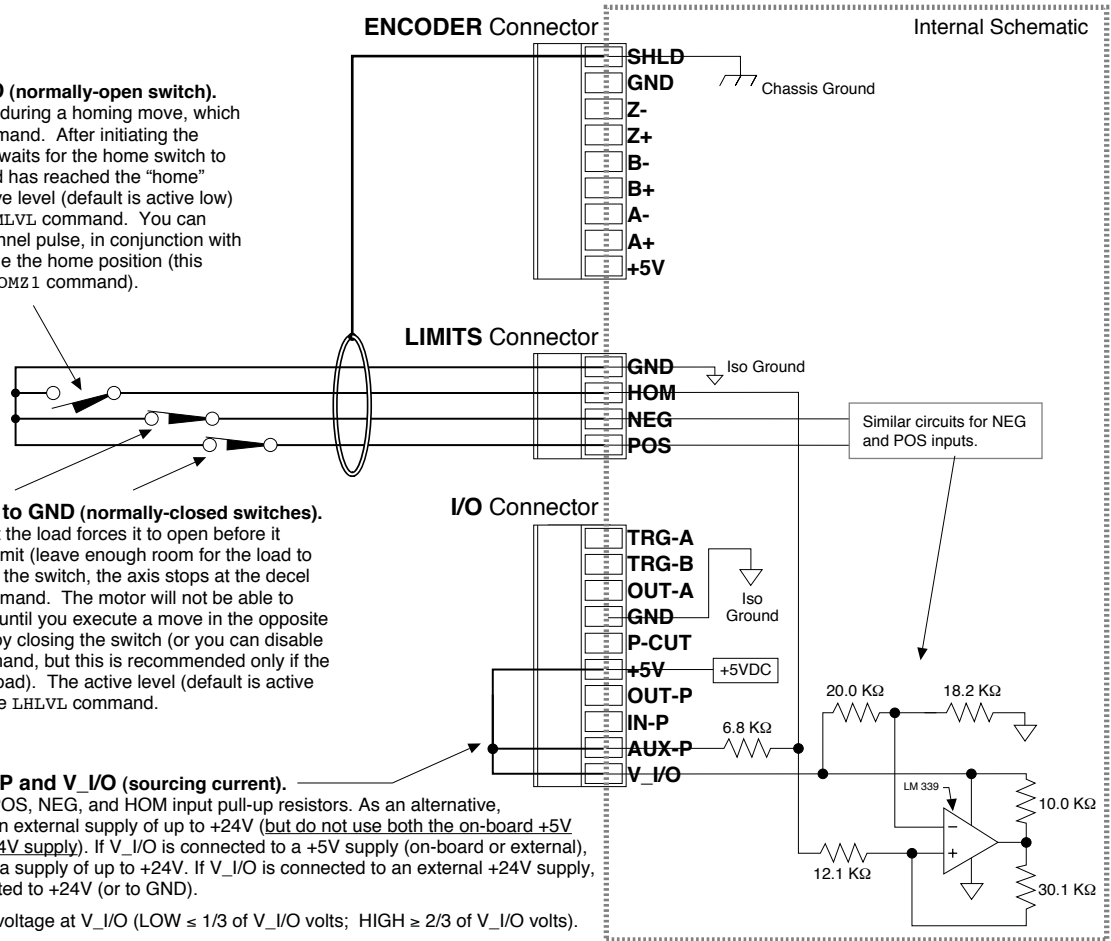

## PIN OUTS & SPECIFICATIONS (4-pin LIMITS Connector)

Name	In/Out	Description
GND	—	Isolated ground.
HOM	IN	Home limit input.
NEG	IN	Negative-direction end-of-travel limit input.
POS	IN	Positive-direction end-of-travel limit input.

- Specification for all limit inputs**
- Powered by voltage applied to V\_I/O terminal (switching levels: Low ≤ 1/3 of V\_I/O voltage, High ≥ 2/3 of V\_I/O voltage). V\_I/O can handle 5-24V with max. current of 100mA. Internal 6.8 KΩ pull-ups to AUX-P terminal—connect AUX-P to power source (+5V terminal or an external 5-24V supply) to source current, or connect AUX-P to GND to sink current; AUX-P can handle 0-24V with max. current of 50mA. Voltage range for these inputs is 0-24V.
  - Active level for HOM is set with **HOMLVL** (default is active low, requires n.o. switch).
  - Active level for POS & NEG is set with **LHLVL** (default is active low, requires n.c. switch).

# Encoder

## CONNECTIONS & INTERNAL SCHEMATICS

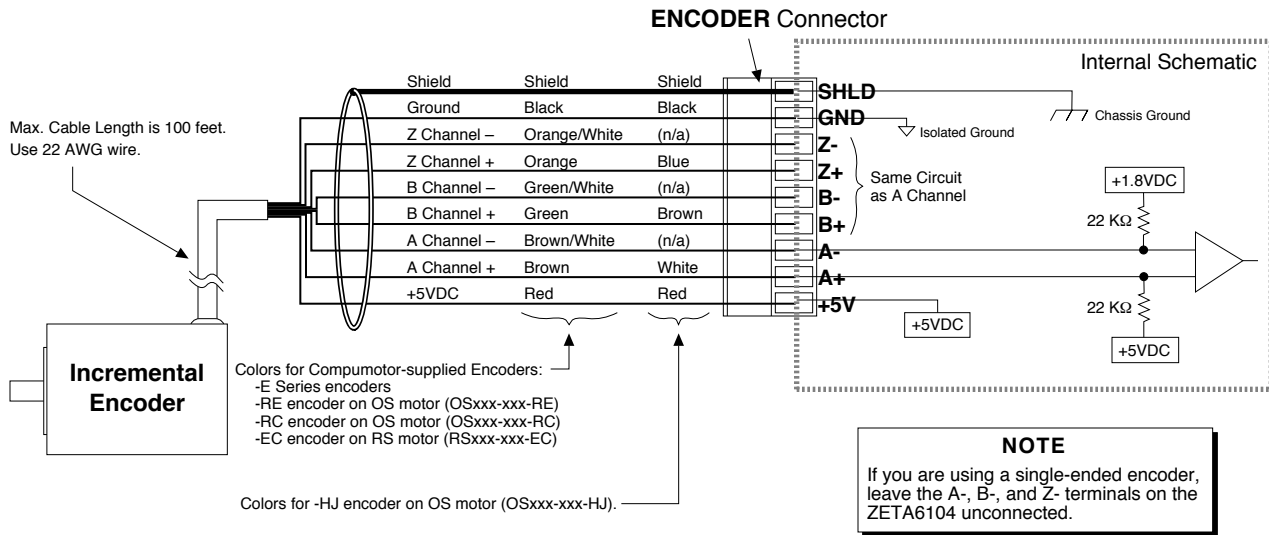

## PIN OUTS & SPECIFICATIONS (9-pin ENCODER Connector)

Pin Name	In/Out	Description
SHLD	----	Shield—Internally connected to chassis ground (earth).
GND	----	Isolated logic ground.
Z-	IN	Z- Channel signal input.
Z+	IN	Z+ Channel signal input.
B-	IN	B- Channel quadrature signal input.
B+	IN	B+ Channel quadrature signal input.
A-	IN	A- Channel quadrature signal input.
A+	IN	A+ Channel quadrature signal input.
+5V	OUT	+5VDC output to power the encoder.

**Specification for all encoder inputs**

Differential comparator accepts two-phase quadrature incremental encoders with differential (recommended) or single-ended outputs. Max. frequency is 1.6 MHz. Minimum time between transitions is 625 ns. TTL-compatible voltage levels: Low  $\leq$  0.4V, High  $\geq$  2.4V. Maximum input voltage is 5VDC.

### Requirements for Non-Compumotor Encoders

- Use incremental encoders with two-phase quadrature output. An index or Z channel output is optional. **Differential outputs are recommended.**
- It must be a 5V (< 200mA) encoder to use the ZETA6104's +5V output. Otherwise, it must be separately powered with TTL-compatible (low  $\leq$  0.4V, high  $\geq$  2.4V) or open-collector outputs.
- The decoded quadrature resolution should be less than the motor resolution by a factor of four to take advantage of the ZETA6104's position maintenance capability.

# Trigger Inputs

## TRG-A/B connected to GND (normally-open switches).

The active level (default is active low) can be changed with the INLVL command.

These inputs are like the general-purpose inputs on the 50-pin header. The differences are (1) the triggers are pulled up via the AUX-P pull-up terminal and powered by the voltage applied to the V\_I/O terminal; and (2) the triggers can be programmed with the INFNci-H command to function as position capture inputs and registration inputs.

## +5V connected to AUX-P and V\_I/O (sourcing current).

Provides +5V power to the TRG-A & TRG-B input pull-up resistors. As an alternative, you can connect AUX-P to an external supply of up to +24V (but do not use both the on-board +5V terminal and an external 5-24V supply). If V\_I/O is connected to a +5V supply (on-board or external), AUX-P can be connected to a supply of up to +24V. If V\_I/O is connected to an external +24V supply, AUX-P must also be connected to +24V (or to GND).

Switching levels depend on voltage at V\_I/O (LOW  $\leq 1/3$  of V\_I/O volts; HIGH  $\geq 2/3$  of V\_I/O volts).

**NOTE:** AUX-P and V\_I/O are also used by the HOM, NEG, POS & P-CUT inputs.

**SINKING CURRENT:** To make the trigger inputs (as well as HOM, NEG, POS & P-CUT) sink current, connect AUX-P to GND.

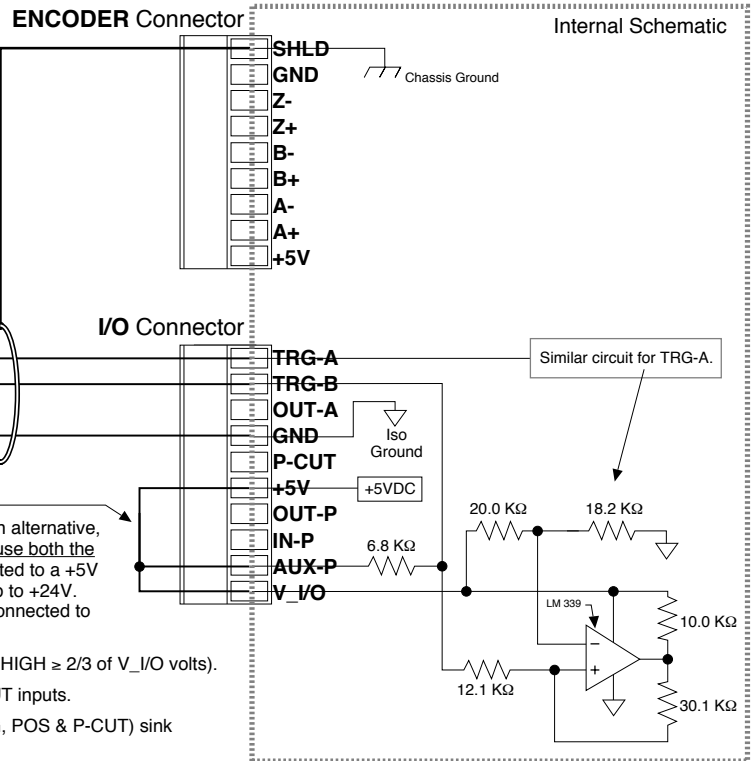

## Connection to a Sinking Output Device

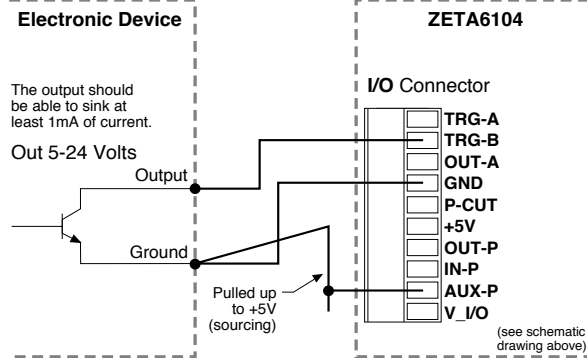

## Connection to a Sourcing Output Device

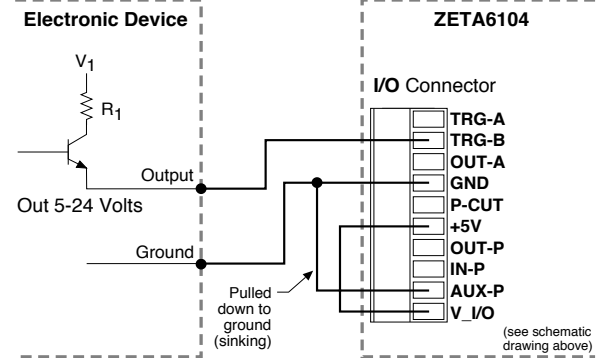

## Connection to a Combination of Sinking & Sourcing Outputs

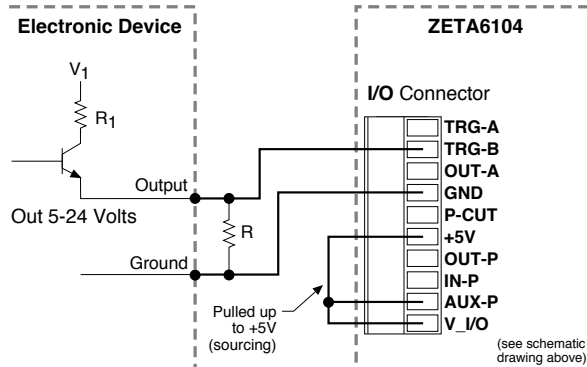

If you will be connecting to a combination of sourcing and sinking outputs, connect AUX-P to +5-24V to accommodate sinking output devices. Then for each individual input connected to a sourcing output, wire an external resistor between the ZETA6104's trigger input terminal and ground (see illustration). The resistor provides a path for current to flow from the device when the output is active.

### PROGRAMMING TIP

**Connecting to a sinking output?** Set the trigger input's active level to low with the INLVL command (0 = active low, default setting).

**Connecting to a sourcing output?** Set the trigger input's active level to high with the INLVL command (1 = active high).

Thus, when the output is active, the TIN status command will report a "1" (indicates that the input is active), regardless of the type of output that is connected.

For details on setting the active level and checking the input status refer to the INLVL and TIN command descriptions in the 6000 Series Software Reference.

# General-Purpose Programmable Inputs & Outputs

## VM50 ADAPTOR — for screw-terminal connections

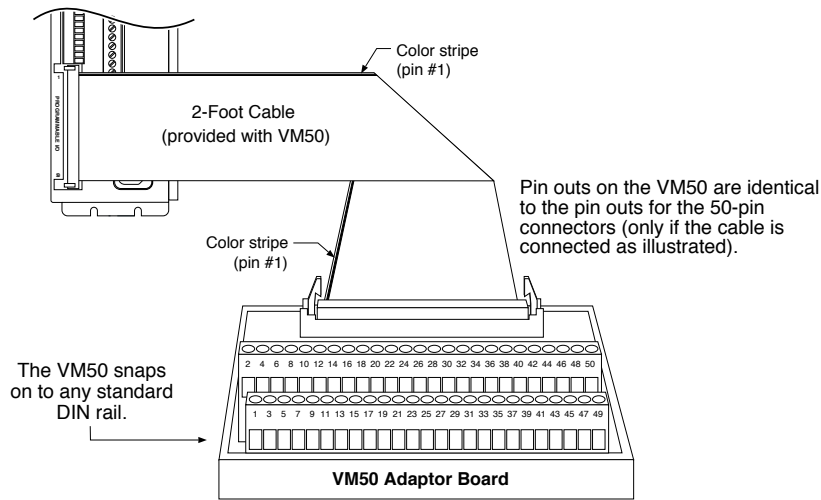

## PIN OUTS & SPECIFICATIONS

Pin	Function	Internal Schematics	Specifications
1	Input #16 (MSB of inputs)	<b>Inputs</b> <p>External 5-24VDC Supply (an alternative to using the on-board +5V terminal)</p> <p>When connecting to a sinking output device, connect IN-P to the +5V terminal OR to a user-supplied external supply of up to 24VDC (but not to both).</p> <p>ISO GND</p> <p>+5VDC</p> <p>IN-P</p> <p>6.8 KΩ</p> <p>Input Connection</p> <p>47 KΩ</p> <p>74HCxx</p> <p>ISO GND</p>	<b>Inputs</b> HCMOS-compatible voltage levels (low $\leq 1.00V$ , high $\geq 3.25V$ ). Voltage range = 0-24V. Sourcing Current: On the I/O connector, connect IN-P to +5V or connect IN-P to an external 5-24VDC power supply (but not to both). Sinking Current: On the I/O connector, connect IN-P to GND. STATUS: Check with TIN or INFNC. Active level: Default is active low, but can be changed to active high with the INLVL command.
3	Input #15		
5	Input #14		
7	Input #13		
9	Input #12		
11	Input #11		
13	Input #10		
15	Input #9		
17	Output #8 (MSB of outputs)		
19	Output #7		
21	Output #6		
23	Output #5		
25	Input #8		
27	Input #7		
29	Input #6		
31	Input #5		
33	Output #4		
35	Output #3		
37	Output #2		
39	Output #1 (LSB of outputs)		
41	Input #4		
43	Input #3		
45	Input #2		
47	Input #1 (LSB of inputs)		
49	+5VDC		

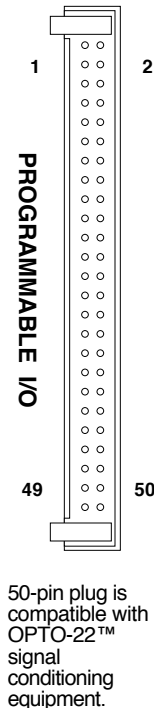

**NOTE:** All even-numbered pins are connected to a common logic ground (DC ground) — see drawing on page 7. LSB = least significant bit; MSB = most significant bit

**CAUTION:** You must select either the on-board +5V terminal or an external power supply to power the IN-P and OUT-P pull-up resistors. Connecting IN-P or OUT-P to the +5V terminal and an external supply will **damage the ZETA6104**. (The same rule applies to the AUX-P terminal.)

# INPUT CONNECTIONS — Connecting to electronic devices such as PLCs

## Connection to a Sinking Output Device

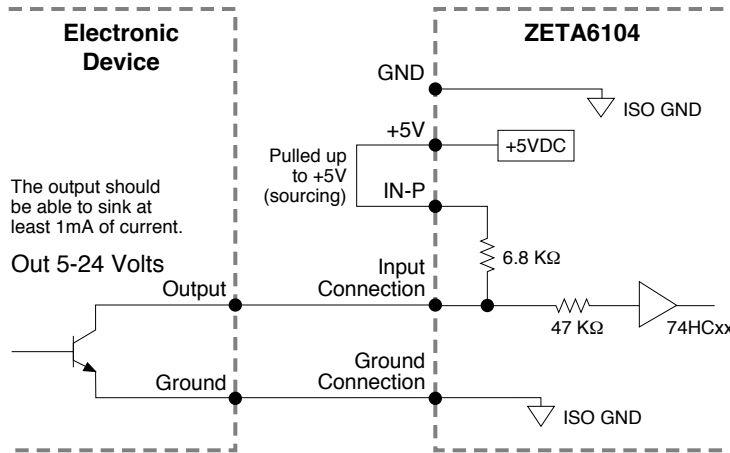

## Connection to a Sourcing Output Device

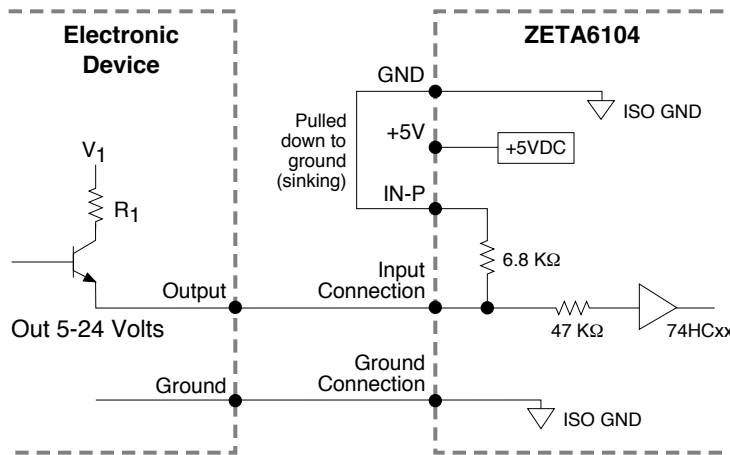

## Connection to a Combination of Sinking & Sourcing Outputs

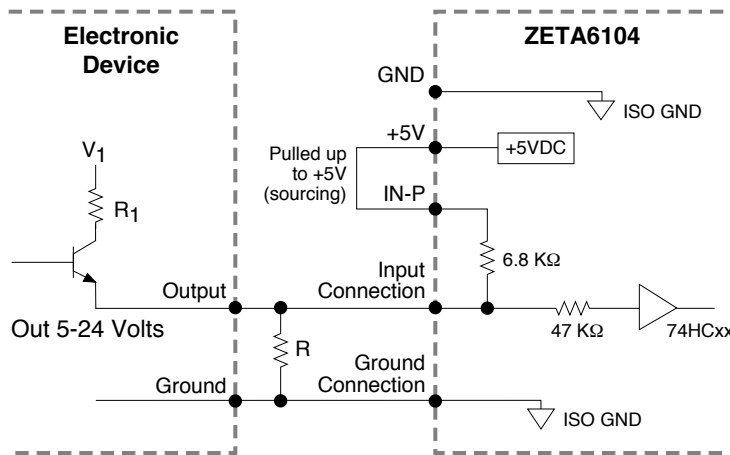

Typical value for R = 450Ω (assuming R<sub>1</sub> = 0)

**Note:** The value of R may vary depending on the value of R<sub>1</sub> and V<sub>1</sub>.

### PROGRAMMING TIP

**Connecting to a sinking output?** Set the input's active level to low with the INLVL command (0 = active low).

**Connecting to a sourcing output?** Set the input's active level to high with the INLVL command (1 = active high).

Thus, when the output is active, the TIN status command will report a "1" (indicates that the input is active), regardless of the type of output that is connected.

Details on setting the active level and checking the input status are provided in the 6000 Series Programmer's Guide. Refer also to the INLVL and TIN command descriptions in the 6000 Series Software Reference.

**NOTE:** If you will be connecting to a combination of sourcing and sinking outputs, connect IN-P to +5V (or to an external 5-24VDC supply) to accommodate sinking output devices. Then for each individual input connected to a sourcing output, wire an external resistor between the ZETA6104's programmable input terminal and ground (see "R" in above drawing). The resistor provides a path for current to flow from the device when the output is active.

**OUTPUT CONNECTIONS (includes OUT-A)** – for electronic devices such as PLCs

**Connection to a Sinking Input (active high)**

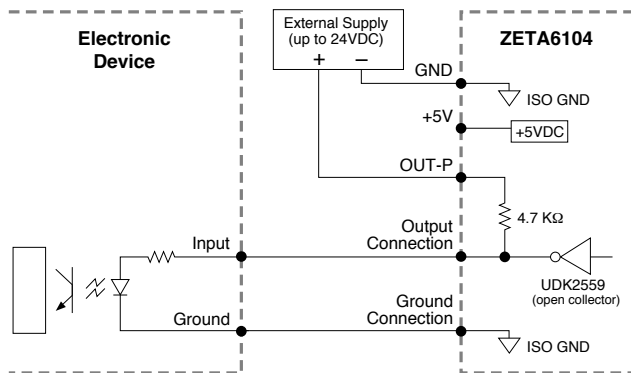

**Connection to a Sourcing Input (active low)**

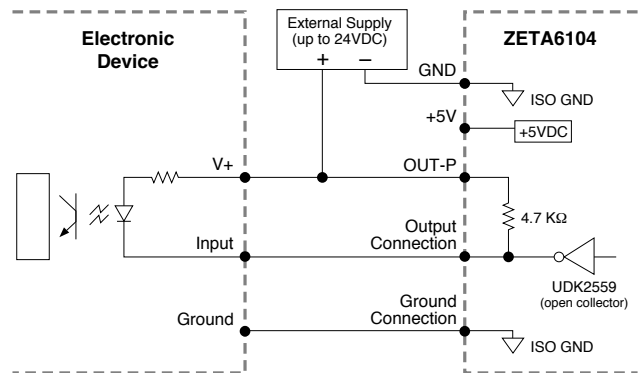

**Connection to a Combination of Sinking & Sourcing Inputs**

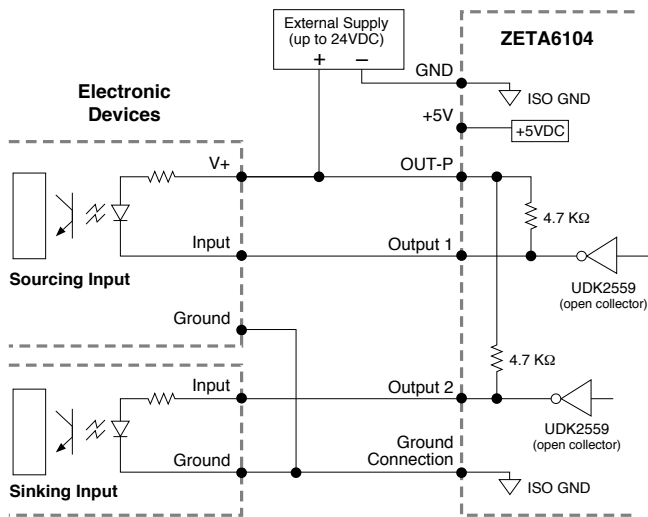

Combinations of sourcing and sinking inputs can be accommodated at the same voltage level. Be aware of the input impedance of the sourcing input module, and make sure that there is enough current flowing through the input module while in parallel with the OUT-P pull-up resistor.

**PROGRAMMING TIP**

**Connecting to an active-high sinking input?** Set the output's active level to high with the OUTLVL command (1 = active high).

**Connecting to an active-low sourcing input?** Set the output's active level to low with the OUTLVL command (∅ = active low).

Thus, when the ZETA6104's output is activated, current will flow through the attached input and the TOU status command will report a "1" (indicates that the output is active), regardless of the type of input that is connected.

Details on setting the active level and checking the output status are provided in the 6000 Series Programmer's Guide. Refer also to the OUTLVL and TOU command descriptions in the 6000 Series Software Reference.

**Connection to an Inductive Load (active low)**

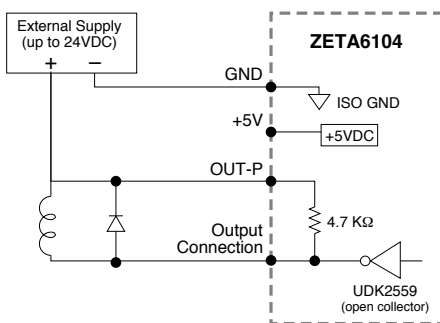

Use an external diode when driving inductive loads. Connect the diode in parallel to the inductive load, attaching the anode to the ZETA6104 output and the cathode to the supply voltage of the inductive load.

# THUMBWHEEL CONNECTIONS — for entering BCD data

## Connection to the Compumotor TM8 Module

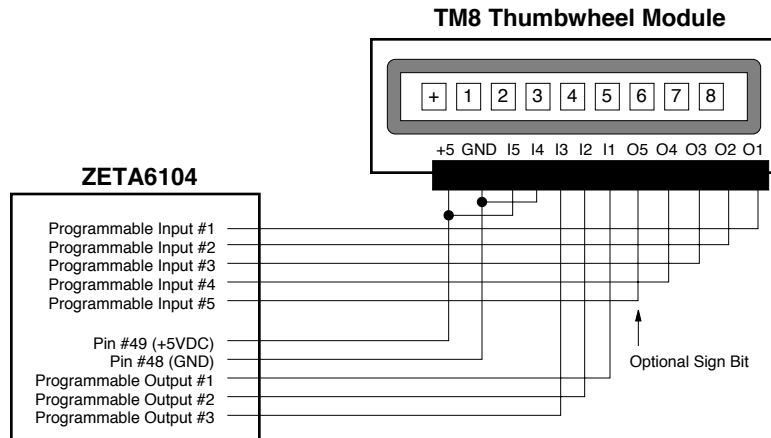

## Connection to your own Thumbwheel Module

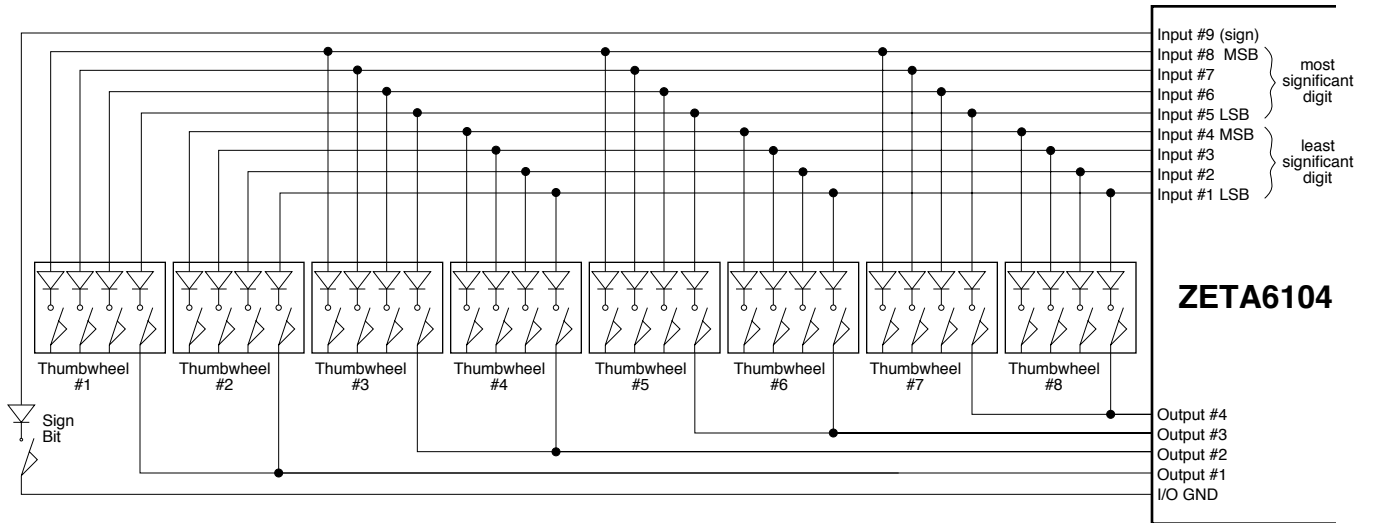

# RP240 Remote Operator Panel

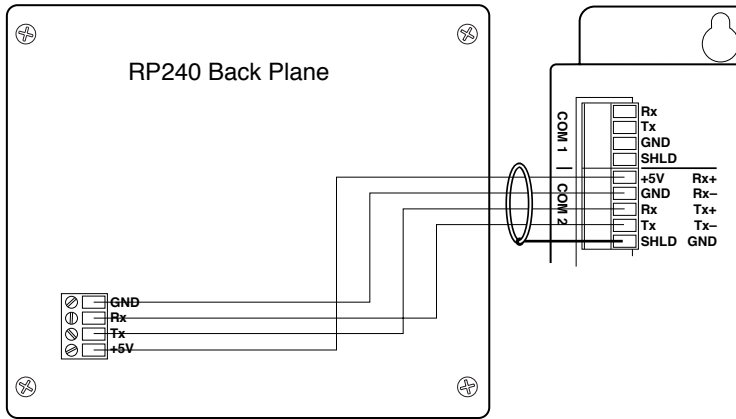

### RP240 Connections when using RS-485

If you will use RS-485 serial communication, you must connect the RP240 to the **COM 1** connector (and connect the RP240's +5V lead to the +5V terminal on the I/O connector).

In addition, you will have to issue these commands to configure the ZETA6104 to communicate successfully with the RP240 connected to **COM 1** and with RS-485 connected to **COM 2**.

PORT1.....Select COM 1 as the affected port.  
 DRPCHK1....On powerup, check for RP240 on COM 1.  
 PORT2.....Select COM 2 as the affected port.  
 DRPCHK0....On powerup, do not check for RP240 on COM 2.

# Input Power

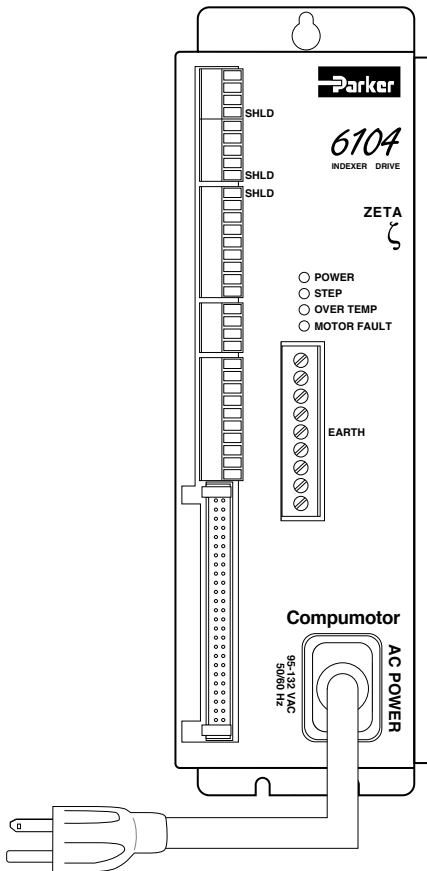

**WARNING:** The motor case (via the EARTH terminal) and the ZETA6104's SHLD terminals are grounded through the AC power connector ground pin. You must provide a proper AC power ground for safety purposes.

### Power Input Specification

95-132VAC, 50/60Hz, single-phase  
 Peak Power requirements depend on the motor you use:

Motor Type	Current (Amps)	Cabinet Loss (W)	Peak Motor Loss (W)	Peak Shaft Power (W)	Peak Total Power (W)	Volt-Amp Rating (VA)
ZETA57-51(S)	1.26	11.9	25	60	97	145
ZETA57-51(P)	2.38	16.1	50	129	195	293
ZETA57-83(S)	1.51	12.7	27	80	120	180
ZETA57-83P	3.13	19.6	54	175	249	373
ZETA57-102(S)	1.76	13.6	30	80	124	185
ZETA57-102P	3.50	21.7	60	186	268	402
ZETA83-62(S)	2.26	15.5	50	120	186	278
ZETA83-62P	4.00	24.8	88	260	373	560
ZETA83-93(S)	2.88	18.4	52	180	250	376
ZETA83-93P	4.00	24.8	72	350	447	671
ZETA83-135(S)	3.50	21.7	57	193	272	408
ZETA83-135P	4.00	24.8	65	355	445	667
OS2HB(S)	1.51	21.1	67	34	122	199
OS2HB(P)	3.01	39.1	187	79	305	466
OS21B(S)	1.88	22.6	61	67	150	240
OS21B(P)	3.75	48.8	180	114	343	509
OS22B(S)	2.14	20.4	55	89	165	262
OS22B(P)	4.00	44.5	147	165	357	542
RS31B(S)	2.26	20.0	50	120	200	300
RS31B(P)	4.00	40.0	110	240	400	600
RS32B(S)	2.88	30.4	61	149	241	372
RS32B(P)	4.00	48.8	170	226	445	668
RS33B(S)	3.50	33.3	73	210	316	493
RS33B(P)	4.00	56.6	164	299	519	769

(S): Series Configuration (P): Parallel Configuration

### Power Cable

Provided in ship kit (p/n 44-014768-01)  
 Length: 6.6 ft (2.0 m)

### LEDs (after power is applied):

POWER ..... On (green).  
 STEP ..... Off. Or green if motion is commanded.  
 OVER TEMP ..... Off. Or red if the internal sensor reaches 131°F (55°C).  
 MOTOR FAULT ..... Off. Or red if there is a short in the motor windings or motor cable, or if the INTERLOCK jumper on the motor connector is removed or extended.



# Lengthening I/O Cables

Bear in mind that lengthening cables increases noise sensitivity. (The maximum length of cables is ultimately determined by the environment in which the equipment will be used.) If you lengthen the cables, follow the precautions below to minimize noise problems.

- Use a minimum wire size of 22 AWG.
- Use twisted pair shielded cables and connect the shield to a **SHLD** terminal on the ZETA6104. Leave the other end of the shield disconnected.
- Do not route I/O signals in the same conduit or wiring trays as high-voltage AC wiring or motor cables.

**Reducing noise on limit, trigger, and P-CUT inputs.** If you are experiencing noise problems, try adding resistors to reduce noise sensitivity (see illustration below).

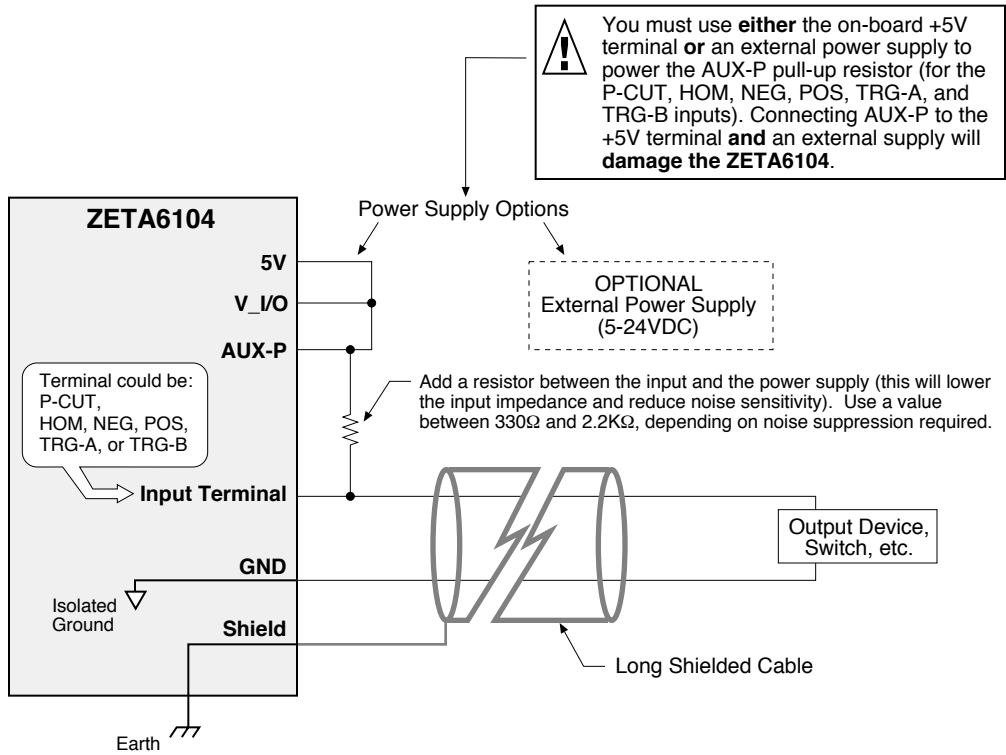

# Testing the Installation

**WARNING**

This test procedure allows you to control I/O and produce motion. Make sure that exercising the I/O will not damage equipment or injure personnel. We recommend that you leave the motor uncoupled from the load, but if you have coupled the load to the motor, make sure that you can move the load without damaging equipment or injuring personnel.

## Test Setup

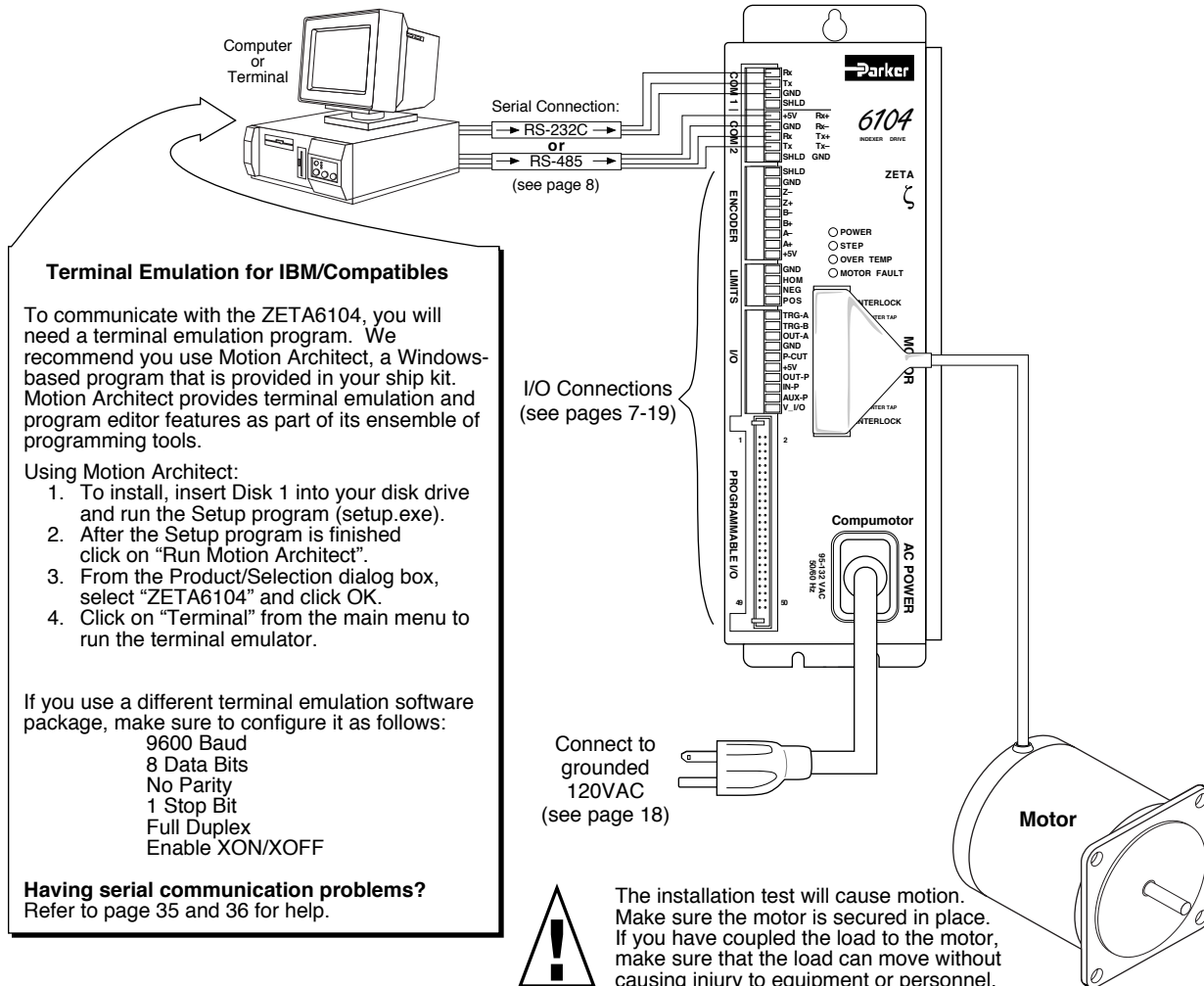

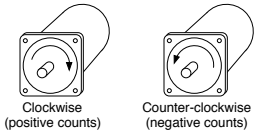
Connections	Test Procedure	Response Format (left to right)
End-of-travel and Home Limits	<p><b>NOTE:</b> If you are not using end-of-travel limits, issue the Disable Limits (LH0) command and ignore the first two bits in each response field.</p> <ol style="list-style-type: none"> <li>1. Enable the hardware end-of-travel limits with the LH3 command.</li> <li>2. Close the end-of-travel switches and open the home switch.</li> <li>3. Enter the TLIM command. The response should be *TLIM110.</li> <li>4. Open the end-of-travel switches and close the home switch.</li> <li>5. Enter the TLIM command. The response should be *TLIM001.</li> <li>6. Close the end-of-travel switches and open the home switch (return to original config).</li> <li>7. Enter the TLIM command. The response should be *TLIM110.</li> </ol>	<p>TLIM response:</p> <p>bit 1 = POS (positive travel) limit bit 2 = NEG (negative travel) limit bit 3 = HOM (home) limit</p>
Motor and Encoder (motion)	<ol style="list-style-type: none"> <li>1. Enter the ENC0 command to enable the motor step mode. Enter the PSET0 command to set the motor position to zero. Enter the TPM command to determine the motor position. The response should be *TPM+0 (motor is at position zero). Enter the D25000 command, followed by the GO command. The motor will move one revolution (25000 steps) in the clockwise direction (viewed from the flange end). Enter the TPM command to determine the motor position. The response should be *TPM+25000 (motor is at position 25000).</li> <li>2. <b>NOTE:</b> Ignore this step if you are <u>not</u> using encoder feedback. This test assumes you are using a 1000-line encoder yielding a 4000 count/rev resolution. Enter the ENC1 command to enable the encoder step mode. Enter the PSET0 command to set the encoder position to zero. Enter the TPE command to determine the encoder position. The response should be *TPE+0 (encoder is at position zero). <b>If the encoder is coupled to the motor shaft:</b> Enter the D4000 command, followed by the GO command. The encoder (and motor) will move one revolution (4000 counts) in the clockwise direction (viewed from the flange end). <b>If the encoder is <u>not</u> coupled to the motor shaft:</b> Manually rotate the encoder shaft one revolution in the clockwise direction (viewed from the flange end). Enter the TPE command to determine the encoder position. The response should be *TPE+4000 (encoder is at position 4000). Enter the ENC0 command to return the ZETA6104 to the default motor step mode.</li> </ol>	<p>TPM response = motor counts</p> <p>TPE response = encoder counts</p> <p>Direction of rotation:</p> 
Programmable Inputs (incl. triggers)	<ol style="list-style-type: none"> <li>1. Open the input switches or turn off the device driving the inputs.</li> <li>2. Enter the TIN command. The response should be *TIN0000_0000_0000_0000_00.</li> <li>3. Close the input switches or turn on the device driving the inputs.</li> <li>4. Enter the TIN command. The response should be *TIN1111_1111_1111_1111_11.</li> </ol>	<p>TIN response:</p> <p>bits 1-16 = prog. inputs 1-16 bits 17 &amp; 18 = TRG-A &amp; TRG-B</p>
Programmable Outputs	<ol style="list-style-type: none"> <li>1. Enter the OUTALL1,9,1 command to turn on (sink current on) all programmable outputs. Verify that the device(s) connected to the outputs activated properly.</li> <li>2. Enter the TOUT command. The response should be *TOUT1111_1111_1.</li> <li>3. Enter the OUTALL1,9,0 command to turn off all programmable outputs. Verify that the device(s) connected to the outputs de-activated properly.</li> <li>4. Enter the TOUT command. The response should be *TOUT0000_0000_0.</li> </ol>	<p>TOUT response:</p> <p>bits 1-8 = prog. outputs 1-8 bit 9 = OUT-A</p>
RP240	<ol style="list-style-type: none"> <li>1. Cycle power to the ZETA6104.</li> <li>2. If the RP240 is connected properly, the RP240's status LED should be green and one of the lines on the computer or terminal display should read *RP240 CONNECTED. If the RP240's status LED is off, check to make sure the +5V connection is secure. If the RP240's status LED is green, but the message on the terminal reads *NO REMOTE PANEL, the RP240 Rx and Tx lines are probably switched. Remove power and correct.</li> <li>3. Assuming you have not written a program to manipulate the RP240 display, the RP240 screen should display the following:</li> </ol> <div style="border: 1px solid black; padding: 5px; width: fit-content; margin: 10px auto;"> <p style="text-align: center;">COMPUMOTOR 6104 INDEXER/DRIVE RUN JOG STATUS DRIVE DISPLAY ETC</p> </div>	<div style="border: 1px solid black; padding: 5px;"> <p style="text-align: center;"><b>ASSUMPTIONS</b></p> <ul style="list-style-type: none"> <li>• RP240 connected to <b>COM 2</b></li> <li>• <b>COM 2 (PORT2)</b> configured for RP240. To verify, type these commands: <pre>PORT2 &lt;cr&gt; DRPCHK&lt;cr&gt;</pre> The system response should report "<b>*DRPCHK3</b>".</li> </ul> </div>
Pulse Cut	<ol style="list-style-type: none"> <li>1. Open the P-CUT switch or turn off the device driving the P-CUT input.</li> <li>2. Enter the TINO command (note the condition of the 6<sup>th</sup> bit from the left). The response should be *TINO0000_0000.</li> <li>3. Close the P-CUT switch or turn on the device driving the P-CUT input.</li> <li>4. Enter the TINO command. The response should be *TINO0000_0100.</li> </ol>	<p>TINO response:</p> <p>bit 6 = pulse cut input bits 1-5, 7 &amp; 8 are not used</p>

## Matching the Motor to the ZETA6104 (OPTIONAL)

Due to slight manufacturing variations, each motor has its own particular characteristics. In the procedure below, you will adjust three potentiometers (*pots*), to match your ZETA6104 to your specific motor. You will also select the best current waveform to use with your motor.

If you purchased a ZETA6104 and ZETA motor *system* (not applicable to OS and RS motors), the ZETA6104 and the ZETA motor were matched to each other at the factory. However, you may still want to perform the matching procedure below, because your operating conditions may not be the same as factory conditions.

The ZETA6104's pots are located behind the removable metal cover on top of the chassis.

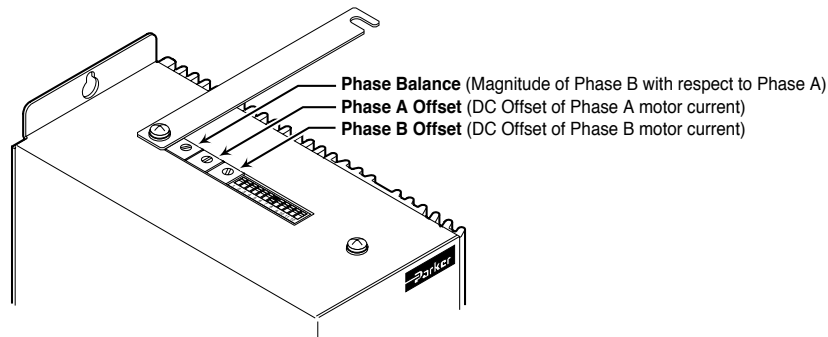

### Before You Start

- Note that if you replace the ZETA6104 unit or the motor, you will have to redo this procedure.
- Set up a serial communication link and terminal emulator (see installation test on page 20).
- Connect the motor to the ZETA6104.
- Secure the motor in a location such that you can turn the pots and feel or hear the motor at the same time. (You should perform this procedure with the motor not coupled to the load, because the characteristics you are matching are those only of the drive/motor combination.)
- Apply AC power when necessary to perform the steps below.

**Step 1** Apply power to the ZETA6104, and allow it to reach a stable operating temperature. This may take up to 30 minutes. For optimum results, perform the matching procedure at the same ambient temperature at which your application will operate.

**Step 2** For the adjustments that follow, consult the table below to find the speed at which to run the motor. These are speeds that cause *resonance* in the unloaded motor. When the motor is running at a resonant speed, you will notice increased noise and vibration. To make resonance the most noticeable, you may need to vary the speed around the value given below for your motor. You can find the resonant speed by touching the motor lightly with your fingertips as you vary the speed. When you feel the strongest vibrations, the motor is running at resonant speed.

Motor	Offset Adjust (rps)	Balance Adjust (rps)	Waveform Adjust (rps)
ZETA57-51	4.72	2.36	1.18
ZETA57-83	4.66	2.33	1.17
ZETA57-102	4.12	2.06	1.03
ZETA83-62	2.96	1.48	0.74
ZETA83-93	2.96	1.48	0.74
ZETA83-135	2.89	1.45	0.73
OS2HB	4.52	2.26	1.13
OS21B	4.49	2.24	1.12
OS22B	4.51	2.26	1.13
RS31B	2.79	1.40	0.70
RS32B	2.72	1.36	0.68
RS33B	2.65	1.32	0.66

Step 3 Run your motor at the resonant speed listed in the *Offset Adjust* column. Vary the speed slightly until you find the resonance point.

To initiate motion, type these commands (followed by a carriage return) to the ZETA6104 from the terminal emulator:

MC1 (This command makes the motion run continuously until you issue a !S command.)  
 vn (This command sets the velocity to n . For example, v4.66 sets the velocity to 4.66 rps.)  
 GO (This command initiate motion.)

To vary the speed while the motor is moving, type these *immediate* commands:

!vn (This command selects the new velocity of n.)  
 !GO (This command changes the motor's velocity to the new velocity value of n.)

**NOTE:** To stop the motor during this procedure, issue the !S command.  
 Re-issue the GO command to resume motion.

Step 4 Adjust the Phase A Offset and Phase B Offset pots for minimum motor vibration and smoothest operation. Alternate between Phase A and Phase B to find the minimum vibration point.

Step 5 Run your motor at the resonant speed listed in the *Balance Adjust* column. Vary the speed slightly until you find the resonance point.

Step 6 Adjust the balance pot until you find the setting that provides minimum motor vibration and smoothest operation.

Step 7 Repeat steps 3–6.

Step 8 Run the motor at the resonant speed listed in the *Waveform Adjust* column. Vary the speed slightly until you find the resonance point.

Step 9 Choose the current waveform that provides minimum motor vibrations and smoothest operation at the speed you selected in step 8. To find the best waveform, compare motor performance as you select different waveforms using the !DWAVEF command.

Waveform	DWAVEF Setting	
-4% 3rd harmonic	!DWAVEF1	← Factory default
-10% 3rd harmonic	!DWAVEF2	
-6% 3rd harmonic	!DWAVEF3	
Pure sine	!DWAVEF4	← Do not use if drive resolution (DRES) is set to 200 steps/rev

NOTE: The DWAVEF command setting is NOT automatically saved in non-volatile memory; therefore, if DWAVEF1 is not adequate, you have to place an alternative DWAVEF setting in a set-up (STARTUP) program. Refer to page 31 for an example.

Step 10 Disconnect AC power to turn off the ZETA6104. Replace the cover over the pots. This completes the matching procedure.

Step 11 Proceed to the next section to mount and couple the motor.

# Mounting & Coupling the Motor

## WARNINGS

- Improper motor mounting and coupling can jeopardize personal safety, and compromise system performance.
- Never disassemble the motor; doing so will cause contamination, significant reduction in magnetization, and loss of torque.
- Improper shaft machining will destroy the motor's bearings, and void the warranty. Consult a factory Applications Engineer (see phone number on inside of front cover) before you machine the motor shaft.

## Mounting the Motor

Use flange bolts to mount rotary step motors. The *pilot*, or centering flange on the motor's front face, can help you position the motor.

Do not use a foot-mount or cradle configuration, because the motor's torque is not evenly distributed around the motor case. When a foot mount is used, for example, any radial load on the motor shaft is multiplied by a much longer lever arm.

The motors can produce very high torque and acceleration. If the mounting is inadequate, this combination of high torque/high acceleration can shear shafts and mounting hardware. Because of shock and vibration that high accelerations can produce, you may need heavier hardware than for static loads of the same magnitude.

Under certain move profiles, the motor can produce low-frequency vibrations in the mounting structure that can cause fatigue in structural members. A mechanical engineer should check the machine design to ensure that the mounting structure is adequate.

### Motor Dimensions

(xxxx) denotes millimeters

#### ZETA Series, 23 Frame

Model	A
ZETA57-51	2.00 ( 50.23)
ZETA57-83	3.10 ( 75.23)
ZETA57-102	4.10 (101.60)

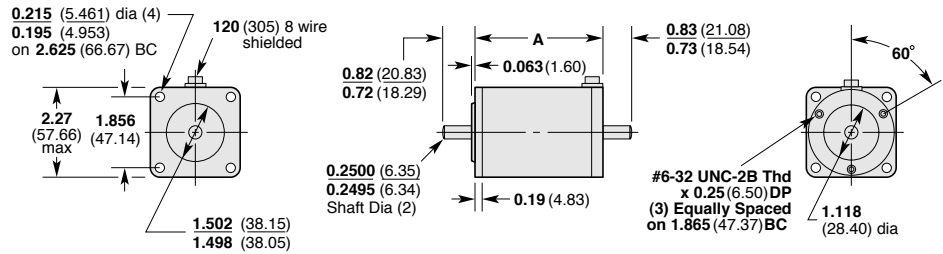

#### ZETA Series, 34 Frame

Model	A
ZETA83-62	2.50 ( 62.00)
ZETA83-93	3.70 ( 93.98)
ZETA83-135	4.10 (129.00)

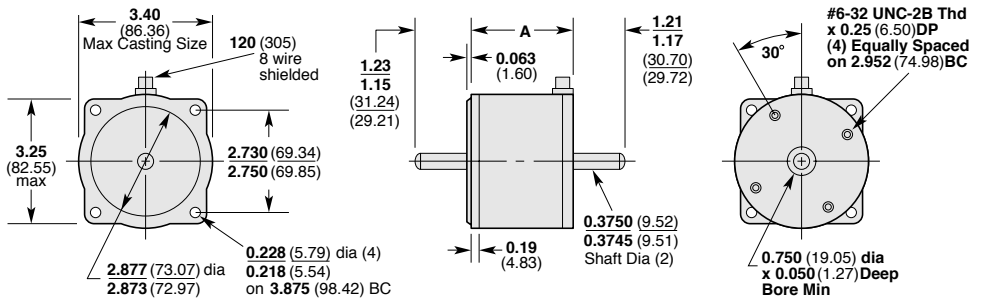

#### O Series, 23 Frame

Model	Lmax
OS2HB	1.60 (40.70)
OS21B	2.06 (52.40)
OS22B	3.10 (78.80)

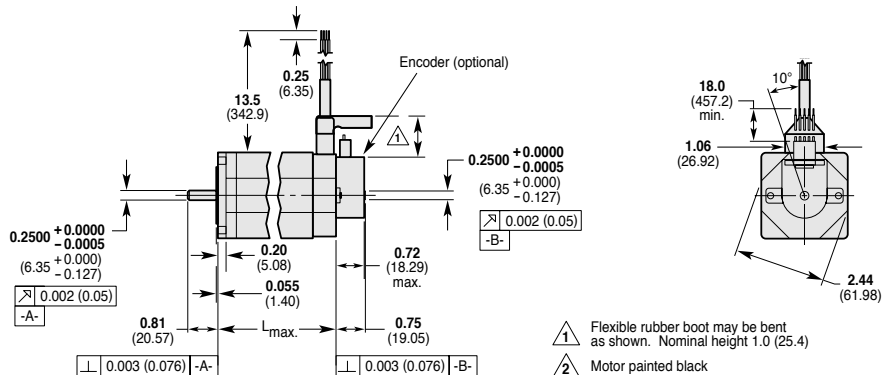

## R Series, 23 Frame End Bell Construction (NPS)

Model	Lmax	L2
RS31B-□□NPS	3.62 ( 91.95)	2.87 ( 72.90)
RS32B-□□NPS	4.77 (121.16)	4.02 (102.11)
RS32B-□□NPS	6.05 (153.67)	5.30 (134.62)

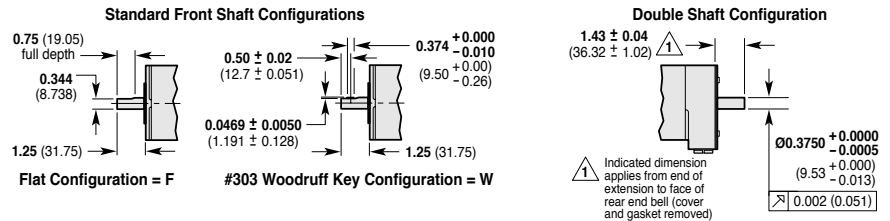
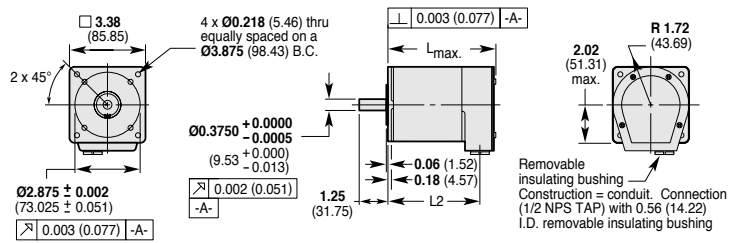

## R Series, 34 Frame Regular Construction (R10)

Model	Lmax
RS31B-□□R10	2.58 ( 65.54)
RS32B-□□R10	3.76 ( 95.51)
RS32B-□□R10	5.06 (128.53)

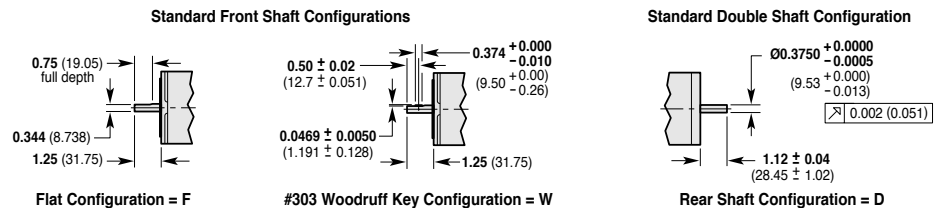
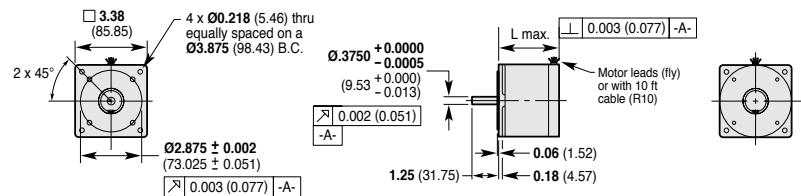

## Motor Temperature & Cooling

The motor's face flange is used not only for mounting; it is also a *heatsink*. Mount the face flange to a large thermal mass, such as a thick steel plate. This is the best way to cool the motor. Heat will be conducted from inside the motor, through the face flange, and dissipated in the thermal mass. You can also use a fan to blow air across the motor for increased cooling, if you do not get enough cooling by conduction through the face flange.

In addition, the ZETA6104 has an automatic standby current feature that reduces motor current by 50% if no step pulses have been commanded for a period of 1 second or more. (**WARNING:** torque is also reduced.) Full current is restored upon the first step pulse. To enable this feature use, the DAUTOS1 command (default is disabled, DAUTOSØ). The DAUTOS command setting is NOT automatically saved in non-volatile memory; therefore, if you intend to use this mode on power up, you have to place the DAUTOS1 command in a set-up (STARTP) program—see example on page 31.

## Coupling the Motor

To ensure maximum performance, align the motor shaft and load as accurately as possible (although some misalignment may be unavoidable). The type of misalignment will affect your choice of coupler.

**Single-Flex Coupling:** Use for angular misalignment only. One (only) one of the shafts must be free to move in the radial direction without constraint. Do not use a single-flex coupling with parallel misalignment—this will bend the shafts, causing excessive bearing loads and premature failure.

**Double-Flex Coupling:** Use whenever two shafts are joined with parallel misalignment, or a combination of angular and parallel misalignment. Single-flex and double-flex couplings may or may not accept end play, depending on their design.

**Rigid Coupling:** Not recommended, because they cannot compensate for *any* misalignment. Use only if the motor or load is on some form of floating mounts that allow for alignment compensation. Rigid couplings can also be used when the load is supported entirely by the motor's bearings. A small mirror connected to a motor shaft is an example of such an application.

**Coupling Manufacturers:** HUCO, 70 Mitchell Blvd, Suite 201, San Rafael, CA 94903, (415) 492-0278  
ROCOM CORP., 5957 Engineer Drive, Huntington Beach, CA 92649, (714) 891-9922

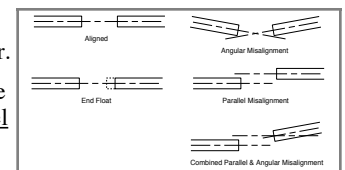

# Optimizing System Performance (OPTIONAL)

---

The ZETA6104 automatically switches between the damping circuits, based upon the motor's speed.

The ZETA6104 is equipped with three damping circuits that minimize resonance and ringing, and thus enhance stepper performance:

- **Anti-Resonance** – General-purpose damping circuit. The ZETA6104 ships from the factory with anti-resonance enabled (see DAREN command). No configuration is necessary. Anti-resonance provides aggressive and effective damping at speeds greater than 3 revolutions per second (rps). If you are using a high-inductance motor (not applicable to ZETA, OS or RS motors), you should disable anti-resonance with the DARENØ command.
- **Active Damping** – Extremely powerful damping circuit at speeds greater than 3 rps. The ZETA6104 ships from the factory with active damping disabled. To enable active damping and optimize it for a specific motor size and load, refer to the *Configuring Active Damping* procedure below.
- **Electronic Viscosity** – Provides passive damping at lower speeds (from rest to 3 rps). The ZETA6104 ships with electronic viscosity disabled. To enable electronic viscosity and optimize it for a specific application, refer to the *Configuring Electronic Viscosity* procedure below.

For a theoretical discussion about these three circuits and how they minimize resonance and ringing, refer to Appendix A.

**NOTE:** You need to "match the motor to the ZETA6104" before you can configure active damping or electronic viscosity. Refer to the matching procedure on page 22.

## Configuring Active Damping

### Before You Start

- **Couple the motor to the load** (see pages 24-25 for details). Active damping must be configured under the normal mechanical operating conditions for your application.
- **Record the setup command settings.** The procedure below helps you identify the appropriate set-up commands (DMTIND, DMTSTT, and DACTDP) that will prepare your system for optimized performance. These commands are saved in non-volatile memory. However, you may still want to record these values so you can later place them in a set-up program (a set-up program executes user-specified commands that establish power-up operational defaults for your application). Page 31 shows an example of how to place these commands in a set-up (STARTP) program.

- Step 1 **Verify correct motor-to-ZETA6104 matching.** See *Matching the Motor to the ZETA6104* on page 22. To be fully effective, the active damping circuit requires proper matching. If you are replacing a component (new ZETA6104 or motor in an existing application), you must rematch your system.



Step 2

**Establish appropriate inductance and static torque settings.** If you ordered a ZETA6104 and a ZETA motor together as a “system”, these settings were made at the factory (OS and RS motors may not be ordered as a “system”). Use the DMTIND command to set the inductance, and use the DMTSTT command to set the static torque (see table below). The DMTIND and DMTSTT values are automatically saved in battery-backed RAM.

Motor	--- INDUCTANCE ---		--- STATIC TORQUE ---		
	Range MH	DMTIND Setting	Range N-m	Oz-in	DMTSTT Setting
ZETA57-51(S) ZETA57-51(P)	20.08 & greater 5.03 – 10.30	DMTIND1 * DMTIND3	0.26 – 0.72 0.26 – 0.72	36 – 100 36 – 100	DMTSTT1 * DMTSTT1 *
ZETA57-83(S) ZETA57-83(P)	20.08 & greater 5.03 – 10.30	DMTIND1 * DMTIND3	0.26 – 0.72 0.26 – 0.72	36 – 100 36 – 100	DMTSTT1 * DMTSTT1 *
ZETA57-102(S) ZETA57-102(P)	20.08 & greater 5.03 – 10.30	DMTIND1 * DMTIND3	0.73 – 1.41 0.73 – 1.41	101 – 200 101 – 200	DMTSTT2 DMTSTT2
ZETA83-62(S) ZETA83-62(P)	10.31 – 20.07 less than 5.02	DMTIND2 DMTIND4	0.73 – 1.41 0.73 – 1.41	101 – 200 101 – 200	DMTSTT2 DMTSTT2
ZETA83-93(S) ZETA83-93(P)	10.31 – 20.07 less than 5.02	DMTIND2 DMTIND4	1.42 – 2.33 1.42 – 2.33	201 – 330 201 – 330	DMTSTT3 DMTSTT3
ZETA83-135(S) ZETA83-135(P)	10.31 – 20.07 less than 5.02	DMTIND2 DMTIND4	2.34 – 3.48 1.42 – 2.33	331 – 492 201 – 330	DMTSTT4 DMTSTT2
OS2HB(S) OS2HB(P)	5.03 – 10.30 less than 5.02	DMTIND3 DMTIND4	0.26 – 0.72 0.26 – 0.72	36 – 100 36 – 100	DMTSTT1 * DMTSTT1 *
OS21B(S) OS21B(P)	10.31 – 20.07 less than 5.02	DMTIND2 DMTIND4	0.26 – 0.72 0.26 – 0.72	36 – 100 36 – 100	DMTSTT1 * DMTSTT1 *
OS22B(S) OS22B(P)	10.31 – 20.07 less than 5.02	DMTIND2 DMTIND4	0.73 – 1.41 0.73 – 1.41	101 – 200 101 – 200	DMTSTT2 DMTSTT2
RS31B(S) RS31B(P)	10.31 – 20.07 less than 5.02	DMTIND2 DMTIND4	0.73 – 1.41 0.73 – 1.41	101 – 200 101 – 200	DMTSTT2 DMTSTT2
RS32B(S) RS32B(P)	10.31 – 20.07 less than 5.02	DMTIND2 DMTIND4	1.42 – 2.33 1.42 – 2.33	201 – 330 201 – 330	DMTSTT3 DMTSTT3
RS33B(S) RS33B(P)	5.03 – 10.30 less than 5.02	DMTIND3 DMTIND4	2.34 – 3.48 2.34 – 3.48	331 – 492 331 – 492	DMTSTT4 DMTSTT4

(S) = Series Connection; (P) = Parallel Connection  
 \* = Factory default setting (unless you ordered the ZETA6104 with a ZETA motor as a “system”).

Step 3

**Calculate only the maximum Active Damping (DACTDP) setting.**

**CAUTION**

The purpose of this step is to identify the maximum DACTDP value for your system—**DO NOT enter the DACTDP command now**. In steps 5-7 of this procedure, never set the DACTDP value higher than this maximum setting.

To calculate the maximum DACTDP value, first calculate your system’s *total* inertia (include the motor’s rotor inertia—see table on page 3). Then consult the table of inertia ranges below to find the DACTDP setting that corresponds to your system’s total inertia. If you are on the boundary between two settings, pick the lower of the two numbers.

DACTDP Setting	Total Inertia kg-cm <sup>2</sup>	Total Inertia kg-m <sup>2</sup> x 10 <sup>-6</sup>	Total Inertia oz-in <sup>2</sup>
DACTDP15	0.088 to 0.205	8.8 to 20.5	0.481 to 1.121
DACTDP14	0.205 to 0.572	20.5 to 57.2	1.121 to 3.144
DACTDP13	0.572 to 1.069	57.2 to 106.9	3.127 to 5.845
DACTDP12	1.069 to 1.754	106.9 to 175.4	5.845 to 9.590
DACTDP11	1.754 to 2.727	175.4 to 272.7	9.590 to 14.910
DACTDP10	2.727 to 3.715	272.7 to 371.5	14.910 to 20.312
DACTDP9	3.715 to 5.020	371.5 to 502.0	20.312 to 27.447
DACTDP8	5.020 to 6.275	502.0 to 627.5	27.447 to 34.308
DACTDP7	6.275 to 8.045	627.5 to 804.5	34.308 to 43.986
DACTDP6	8.045 to 9.595	804.5 to 959.5	43.986 to 52.460
DACTDP5	9.595 to 11.760	959.5 to 1176.0	52.460 to 64.297
DACTDP4	11.760 to 14.250	1176.0 to 1425.0	64.297 to 77.884
DACTDP3	14.250 to 15.900	1425.0 to 1590.0	77.884 to 86.905
DACTDP2	15.900 to 17.770	1590.0 to 1777.0	86.905 to 97.129
DACTDP1	17.770 to 20.570	1777.0 to 2057.0	97.129 to 112.465
DACTDP0	Active Damping Disabled (factory default)		

Step 4 **Make a *baseline* move with active damping disabled.** This is your baseline move. Notice the sound, amount of motor vibration, etc. This move shows how your system operates with anti-resonance enabled, and active damping disabled. Each time you adjust the DACTDP setting (in steps 5-7), you will compare results against this baseline move.

1. Issue the DACTDP0 command to disable active damping.
2. Make a move that is representative of your application, with similar velocity and acceleration. The velocity must be greater than 3 rps, in order for the ZETA6104 to activate anti-resonance or active damping.

**WARNING**  
 Make sure that causing motion will not damage equipment or injure personnel.

The following six commands illustrate a simple incremental point-to-point move:

```
MC0      ; select the preset positioning mode
MA0      ; select the incremental preset positioning mode
A10      ; set the acceleration to 10 revs/sec/sec
V8       ; set the velocity to 8 revs/sec/sec
D250000  ; set the distance to 250,000 steps, equal to 10 revs
GO       ; initiate the move
; *****
; * NOTE: To stop a move in progress, issue the !S command.      *
; * To repeat the move, issue the GO command. To reverse        *
; * direction, issue the D~ command and the GO command.        *
; *****
```

Step 5 **Make a move with active damping enabled.** Compare the sound and vibration to the baseline move.

1. Issue the DACTDP1 command to enable active damping. This enables active damping at its lowest setting, and inhibits anti-resonance.
2. Make a move that is representative of your application. Use the same motion parameters that you set up in step 4. If you have not changed these settings, simply issue the GO command.

Step 6 **Increase the setting.** Issue the DACTDP2 command (unless DACTDP1 is your calculated maximum—see step 3). Make the move again. Compare the sound and vibration to the levels obtained at DACTDP1.

Step 7 **Find the ideal DACTDP setting.** Continue to increase the DACTDP setting by single increments. During a repetitive move, you can change the setting “on the fly” (while the move is in progress) if you precede the DACTDP command with a “!” (e.g., !DACTDP2). This allows you to immediately compare two different settings.

Increase the setting until you obtain optimum results for your move. This will be the setting that yields the lowest audible noise and smoothest motor operation. Write down this setting so that you can include it in your programming (perhaps in the set-up program).

**Never exceed your maximum setting (see step 3).** For many applications, you will not need to go as high as the maximum setting. If you do not see perceptible improvement from one switch setting to the next, use the lower switch setting.

Higher switch settings result in higher dynamic motor current during transients, which can cause increased motor heating. Higher current also increases motor torque, resulting in sharper accelerations that can jerk or stress the mechanics in your system. If you test each intermediate DACTDP setting, you can evaluate the effects on your mechanics as you gradually increase damping.

# Configuring Electronic Viscosity (EV)

## Before You Start

- If you configured active damping (see procedure above), leave the DACTDP setting set at the value you chose. You do not need to disable active damping while you configure EV.
- **Couple the motor to the load** (see pages 24-25 for details). EV must be configured under the normal mechanical operating conditions for your application.
- **Record the DELVIS command setting.** The procedure below helps you identify the appropriate set-up command (DELVIS) that will prepare your system for optimized performance. DELVIS is not saved in non-volatile memory. Therefore, you should write down this command as you qualify it in this procedure, then place it in a program. Page 31 shows an example of how to place DELVIS in a set-up (STARTP) program (a set-up program executes user-specified commands that establish power-up operational defaults for your application).

- Step 1 **Verify correct motor-to-ZETA6104 matching.** See *Matching the Motor to the ZETA6104* on page 22. To be fully effective, the active damping circuit requires proper matching. If you are replacing a component (new ZETA6104 or motor) in an existing application, you must rematch your system.
- Step 2 **Make a baseline move with EV disabled.** This is your baseline move. Notice the sound, amount of motor vibration, perceptible ringing, etc. This move shows how your system operates with EV disabled. Each time you adjust the DELVIS setting (in steps 3 & 4), you will compare results against this baseline move.
1. Issue the DELVIS0 command to disable active damping.
  2. Make a move that is representative of your application, with similar velocity and acceleration. The velocity must 3 rps or less, in order for the ZETA6104 to activate EV.

## WARNING

Make sure that causing motion will not damage equipment or injure personnel.

The following six commands illustrate a simple incremental point-to-point move:

```
MC0      ; select the preset positioning mode
MA0      ; select the incremental preset positioning mode
A10      ; set the acceleration to 10 revs/sec/sec
V2       ; set the velocity to 2 revs/sec/sec
D250000  ; set the distance to 250,000 steps, equal to 10 revs
GO       ; initiate the move
; *****
; * NOTE: To stop a move in progress, issue the !S command. *
; * To repeat the move, issue the GO command. To reverse *
; * direction, issue the D~ command and the GO command. *
; *****
```

- Step 3 **Make a move with EV enabled.** Compare the results with the baseline move.
1. Issue the DELVIS1 command to enable EV.
  2. Make a move that is representative of your application. Use the same motion parameters that you set up in step 1. If you have not changed these settings, simply issue the GO command.
- Step 4 **Find the ideal EV setting.** Continue to increase the DELVIS setting by single increments (the maximum setting is DELVIS7), and executing a move. Repeat this step until you find the setting that gives the best performance. You can try all seven settings. Incorrect settings will not cause damage.

During a repetitive move, you can change the setting “on the fly” (while the move is in progress) if you precede the DELVIS command with a “!” (e.g., !DELVIS2). This allows you to immediately compare two different settings.

# Record Your System's Configuration

You may wish to record your configuration information in the chart below.

Axis Name	<input type="text"/>												
Motor Size	<input type="text"/>											S	P
Motor Inductance Setting (DMTIND)	<input type="text"/>												
Motor Static Torque Setting (DMTSTT)	<input type="text"/>												
Waveform Setting (DWAVEF)	<input type="text"/>												
Electronic Viscosity Setting (DELVIS)	<input type="text"/>												
Active Damping Setting (DACTDP)	<input type="text"/>												
Anti-Resonance Enabled? (DAREN1)	<input type="checkbox"/> Yes			<input type="checkbox"/> No									
Current Standby Enabled? (DAUTOS1)	<input type="checkbox"/> Yes			<input type="checkbox"/> No									
COM 1 Serial Port Function	<input type="checkbox"/> RS-232			<input type="checkbox"/> RP240			<input type="checkbox"/> RS-485						
COM 2 Serial Port Function	<input type="checkbox"/> RS-232			<input type="checkbox"/> RP240			<input type="checkbox"/> RS-485						
RS-485 Resistor Values	<input type="text"/>			Terminate			<input type="text"/>						
DIP Switch Settings	OFF	<input type="checkbox"/>	<input type="checkbox"/>	<input type="checkbox"/>	<input type="checkbox"/>	<input type="checkbox"/>	<input type="checkbox"/>	<input type="checkbox"/>	<input type="checkbox"/>	<input type="checkbox"/>	<input type="checkbox"/>	<input type="checkbox"/>	<input type="checkbox"/>
	ON	<input type="checkbox"/>	<input type="checkbox"/>	<input type="checkbox"/>	<input type="checkbox"/>	<input type="checkbox"/>	<input type="checkbox"/>	<input type="checkbox"/>	<input type="checkbox"/>	<input type="checkbox"/>	<input type="checkbox"/>	<input type="checkbox"/>	<input type="checkbox"/>

← COM port functions set with internal jumpers and the PORT and DRPCHK commands.  
 ← RS-485 resistors are selected with internal DIP switches, or connected externally.

This chart is repeated, along with other facts, on the *magnetic* information label located on the side of the ZETA6104 chassis. You can leave the label on the ZETA6104, or you can remove it and place it in a convenient location near the ZETA6104 (e.g., on an equipment cabinet door).

Use a marker or pen to write configuration information in the spaces at the bottom of the label. If you have multiple ZETA6104s, you can remove the labels and stack them on top of each other, with the bottom edge of each visible. This shows information about all axes at a glance.

## Recommended Set-up Program Elements

**NOTE**  
 In most applications, the factory default settings are adequate.

Most of the software configuration commands (see table below) are not saved in non-volatile memory and therefore must be executed every time the ZETA6104 is powered up or reset. Therefore, you may wish to include the software configuration commands in the *set-up* program.

The set-up program is automatically executed when the ZETA6104 is powered up or reset; in it, you place the configuration commands that establish the operational readiness you require for your particular application. A sample set-up program is provided below. For more detailed information on creating a set-up program, refer to the *6000 Series Programmer's Guide*.

Command	Function	Factory Default Setting
<b>DACTDP</b>	Enable/disable active damping. Active damping is automatically inhibited at or below 3 rps. If active damping is enabled, anti-resonance is automatically inhibited. (See set-up procedure on page 26.)	<b>DACTDP0</b> (disabled)
<b>DAREN</b>	Enable/disable anti-resonance. Anti-resonance is automatically inhibited at or below 3 rps, and it is inhibited if active damping is enabled.	<b>DAREN1</b> (enabled)
<b>DAUTOS</b>	Enable/disable automatic current standby mode in which current to the motor is reduced to 50% if no pulses are commanded for 1 second. Full current is restored upon the next pulse command.	<b>DAUTOS0</b> (disabled)
<b>DELVIS</b>	Enable/disable electronic viscosity. Electronic viscosity is automatically inhibited above 3 rps. (See set-up procedure on page 29.)	<b>DELVIS0</b> (disabled)
<b>DMTIND</b>	Match the inductance of your motor (used only for active damping).	<b>DMTIND1</b> ( $\geq 20$ MH) *
<b>DMTSTT</b>	Match the motor's static torque (used only for active damping).	<b>DMTSTT1</b> (0.26-0.72 N-m; 36-100 Oz-in) *
<b>DRPCHK</b>	Establish the type of check for an RP240. In general, this command is necessary only if you are using RS-485, which forces the RP240 to be connected to the COM 1 connector, instead of being connected to the COM 2 connector.	<b>DRPCHK3</b> *
<b>DWAVEF</b>	Match the motor waveform (required for matching the motor to the ZETA6104).	<b>DWAVEF1</b> (-4% 3rd harmonic)
<b>ECHO</b>	Enable/disable echoing of characters. If communicating over RS-232 to the master ZETA6104 in an RS-485 multi-drop, see setup requirements on page 36.	<b>ECHO1</b> (enabled; but if using RS-485, COM 2 is changed to ECHO0 by default)
<b>PORT</b>	Identify the COM port to be affected by subsequent serial communication set-up commands (DRPCHK, E, ECHO, EOT, BOT, EOL, ERROK, ERRTBAD, ERRDEF, XONOFF, and ERRLVL).	<b>PORT1</b> (COM 1 is affected)

\* These commands are automatically saved in non-volatile memory. If ordered as a system (with a motor), the ZETA6104 is shipped with the DMTIND and DMTSTT commands set to match the motor.

## Set-up Program Example

**Assumptions:** The ZETA6104 is used with a Zeta83-93 motor wired in series.  
RS-232C is connected to the **COM 1** serial port.  
An RP240 is connected to the **COM 2** serial port.

```
DEF SETUP      ; Begin definition of the program called setup
DWAVEF1       ; Select -4% 3rd harmonic waveform
DMTIND2       ; Set motor inductance for ZETA83-93 motor in series
DMTSTT3       ; Set motor static torque for ZETA83-93 motor in series
DACTDP7       ; Enable active damping for total inertia of 40 oz-in
DELVIS2       ; Enable electronic viscosity with value of 2
DAREN1        ; Enable anti-resonance
PORT1         ; Subsequent serial communication setup affects COM1 port
DRPCHK0       ; COM1 to be used for 6000 language commands
PORT2         ; Subsequent serial communication setup affects COM2 port
DRPCHK1       ; Check COM2 for RP240 -- If no RP240, use for 6000 commands
PORT1         ; Subsequent serial-related commands will affect COM1 port
; *****
; * Insert other appropriate commands in the setup program (e.g., custom *
; * power-up message, scaling factors, input function assignments, output *
; * function assignments, etc.). *
; * See Programmer's Guide, chapter 3, for more information. *
; *****
END           ; End definition of program called setup
STARTP SETUP ; Assign the program named setup as the program to be executed
; on power up or reset
```

## What's Next?

---

By now, you should have completed the following tasks, as instructed earlier in this chapter:

1. Review the general specifications — see page 3
2. Perform configuration/adjustments, as necessary — see pages 4-5
3. Mount the ZETA6104 — see page 6
4. Connect all electrical system components — see pages 7-19  
*Supplemental installation instructions for LVD-compliance are provided in Appendix C.*
5. Test the installation — see pages 20-21
6. Match the motor to the ZETA6104 (OPTIONAL) — see pages 22-23
7. Mount the motor and couple the load — see pages 24-25
8. Optimize system performance (OPTIONAL)  
by implementing Active Damping and Electronic Viscosity — see pages 26-29
9. Record your system configuration information — see pages 30-31

## Program Your Motion Control Functions

You should now be ready to program your ZETA6104 for your application. Knowing your system's motion control requirements, refer now to the *6000 Series Programmer's Guide* for descriptions of the ZETA6104's software features and instructions on how to implement them in your application. Be sure to keep the *6000 Series Software Reference* at hand as a reference for the 6000 Series command descriptions.

For assistance with your programming effort, we recommend that you use the programming tools provided in Motion Architect for Windows (found in your ship kit). Additional powerful programming and product interface tools are available (see below).

### Motion Architect

Motion Architect® is a Microsoft® Windows™ based 6000 product programming tool (included in your ship kit). Motion Architect provides these features (refer to the *Motion Architect User Guide* for detailed information):

- **System configurator and code generator:** Automatically generate controller code for basic system set-up parameters (I/O definitions, feedback device operations, etc.).
- **Program editor:** Create blocks or lines of 6000 controller code, or copy portions of code from previous files. You can save program editor files for later use in BASIC, C, etc., or in the terminal emulator or test panel.
- **Terminal emulator:** Communicating directly with the ZETA6104, you can type in and execute controller code, transfer code files to and from the ZETA6104.
- **Test panel and program tester:** You can create your own test panel to run your programs and check the activity of I/O, motion, system status, etc. This can be invaluable during start-ups and when fine tuning machine performance.
- **On-line context-sensitive help and technical references:** These on-line resources provide help information about Motion Architect, as well as access to hypertext versions of the *6000 Series Software Reference* and the *6000 Series Programmer's Guide*.

### Other Software Tools Available

**Motion Builder™.** A Windows-based iconic programming interface that removes the requirement to learn the 6000 programming language.

**DDE6000™.** Facilitates data exchange between the ZETA6104 and Windows™ applications that support the dynamic data exchange (DDE) protocol. NetDDE™ compatible.

**Motion Toolbox™.** A library of LabVIEW® virtual instruments (VIs) for programming and monitoring the ZETA6104. Available for the Windows environment.

To Order these software packages, contact your local Automation Technology Center (ATC) or distributor.

CHAPTER TWO

# Troubleshooting

## IN THIS CHAPTER

- Troubleshooting basics:
  - Reducing electrical noise
  - Diagnostic LEDs
  - Test options
  - Technical support
- Solutions to common problems
- Resolving serial communication problems
- Product return procedure

# Troubleshooting Basics

---

When your system does not function properly (or as you expect it to operate), the first thing that you must do is identify and isolate the problem. When you have accomplished this, you can effectively begin to resolve the problem.

The first step is to isolate each system component and ensure that each component functions properly when it is run independently. You may have to dismantle your system and put it back together piece by piece to detect the problem. If you have additional units available, you may want to exchange them with existing components in your system to help identify the source of the problem.

Determine if the problem is mechanical, electrical, or software-related. Can you repeat or re-create the problem? Random events may appear to be related, but they are not necessarily contributing factors to your problem. You may be experiencing more than one problem. You must isolate and solve one problem at a time.

Log (document) all testing and problem isolation procedures. You may need to review and consult these notes later. This will also prevent you from duplicating your testing efforts.

Once you isolate the problem, refer to the problem solutions contained in this chapter. If the problem persists, contact your local technical support resource (see *Technical Support* below).

## Reducing Electrical Noise

Refer to the guidelines on page 19. General information on reducing electrical noise can be found in the Engineering Reference section of the Parker Compumotor/Digiplan catalog. Appendix D (page 49) provides guidelines on how to install the ZETA6104 in a manner most likely to minimize the ZETA6104's emissions and to maximize the ZETA6104's immunity to externally generated electromagnetic interference.

## Diagnostic LEDs

**POWER** ..... On (green) if 120VAC connected. Off if no power.  
**STEP**..... Flashes on (green) with each pulse sent to the motor. Off if no pulses.  
**OVER TEMP** ..... On (red) if internal sensor reaches 131°F (55°C). Off = O.K.  
**MOTOR FAULT**.... On (red) if there is a short in the motor windings, if the motor cable is disconnected or shorted, or if the INTERLOCK jumper on the MOTOR connector is removed or extended. Off = O.K.

## Test Options

- **Test Panel.** Motion Architect's Panel Module allows you to set up displays for testing system I/O and operating parameters. Refer to the *Motion Architect User Guide* for details.
- **Hardware Test Procedure** (see pages 20-21).
- **Motion Test.** A test program is available to verify that the ZETA6104 is sending pulses to the motor and that the motor is functioning properly. The test program can be initiated by issuing the TEST command over the serial interface, or by accessing the RP240 TEST menu (see *6000 Series Programmer's Guide* for RP240 menu structure).

### WARNING

The TEST program causes the end-of-travel limits to be ignored. If necessary, disconnect the load to ensure the test moves do not damage your equipment or injure personnel.

## Technical Support

If you cannot solve your system problems using this documentation, contact your local Automation Technology Center (ATC) or distributor for assistance. If you need to talk to our in-house application engineers, please contact us at the numbers listed on the inside cover of this manual. (These numbers are also provided when you issue the HELP command.)

**NOTE:** Compumotor maintains a BBS that contains the latest software upgrades and late-breaking product documentation, a FaxBack system, and a tech support email address.



# Common Problems & Solutions

**NOTE:** Some software-related causes are provided because it is sometimes difficult to identify a problem as either hardware or software related.

Problem	Cause	Solution										
Communication (serial) not operative, or receive garbled characters	<ol style="list-style-type: none"> <li>1. Improper interface connections or communication protocol</li> <li>2. COM port disabled</li> <li>3. In daisy chain or multi-drop, the unit may not be set to proper address</li> </ol>	<ol style="list-style-type: none"> <li>1. See Troubleshooting Serial Communication section below.</li> <li>2.a. Enable serial communication with the E1 command.</li> <li>2.b. If using RS-485, make sure the internal jumpers are set accordingly (see page 5). Make sure COM 2 port is enabled for sending 6000 language commands (execute the PORT2 and DRPCHEK0 commands).</li> <li>3. Verify DIP switch settings (see page 4), or proper use of ADDR command.</li> </ol>										
Direction is reversed.	<ol style="list-style-type: none"> <li>1. Phase of step motor reversed (motor does not move in the commanded direction).</li> <li>2. Phase of encoder reversed (reported TPE direction is reversed).</li> </ol>	<ol style="list-style-type: none"> <li>1. Swap the A+ and A– connection at the MOTOR connector.</li> <li>2. Swap the A+ and A– connection at the ENCODER connector.</li> </ol> <p>SOFTWARE ALTERNATIVE: If the motor (and the encoder if one is used) is reversed, you can use the CMDDIR1 command to reverse the polarity of both the commanded direction and the polarity of the encoder feedback counts.</p>										
Distance, velocity, and accel are incorrect as programmed.	<ol style="list-style-type: none"> <li>1. Incorrect resolution setting.</li> </ol>	<ol style="list-style-type: none"> <li>1.a. Set the drive resolution to 25,000 steps/rev (DRES25000 command).</li> <li>1.b. Set the ERES command setting (default setting is 4,000 counts/rev) to match the post-quadrature resolution of the encoder. <b>Compumotor encoders:</b> <table border="0"> <tr> <td>E Series Encoders .....</td> <td>ERES4000</td> </tr> <tr> <td>OS motor with -HJ encoder (OSxxx-xxx-HJ) .....</td> <td>ERES2048</td> </tr> <tr> <td>OS motor with -RE encoder (OSxxx-xxx-RE) .....</td> <td>ERES4000</td> </tr> <tr> <td>OS motor with -RC encoder (OSxxx-xxx-RC) .....</td> <td>ERES4000</td> </tr> <tr> <td>RS motor with -EC encoder (RSxxx-xxx-EC) .....</td> <td>ERES4000</td> </tr> </table> </li> </ol>	E Series Encoders .....	ERES4000	OS motor with -HJ encoder (OSxxx-xxx-HJ) .....	ERES2048	OS motor with -RE encoder (OSxxx-xxx-RE) .....	ERES4000	OS motor with -RC encoder (OSxxx-xxx-RC) .....	ERES4000	RS motor with -EC encoder (RSxxx-xxx-EC) .....	ERES4000
E Series Encoders .....	ERES4000											
OS motor with -HJ encoder (OSxxx-xxx-HJ) .....	ERES2048											
OS motor with -RE encoder (OSxxx-xxx-RE) .....	ERES4000											
OS motor with -RC encoder (OSxxx-xxx-RC) .....	ERES4000											
RS motor with -EC encoder (RSxxx-xxx-EC) .....	ERES4000											
Encoder counts missing.	<ol style="list-style-type: none"> <li>1. Improper wiring.</li> <li>2. Encoder slipping.</li> <li>3. Encoder too hot.</li> <li>4. Electrical noise.</li> <li>5. Encoder frequency too high.</li> </ol>	<ol style="list-style-type: none"> <li>1. Check wiring.</li> <li>2. Check and tighten encoder coupling.</li> <li>3. Reduce encoder temperature with heatsink, thermal insulator, etc.</li> <li>4.a. Shield wiring.</li> <li>4.b. Use encoder with differential outputs.</li> <li>5. Peak encoder frequency must be below 1.6MHz post-quadrature. Peak frequency must account for velocity ripple.</li> </ol>										
Erratic operation.	<ol style="list-style-type: none"> <li>1. Electrical noise and/or improper shielding.</li> <li>2. Improper wiring.</li> </ol>	<ol style="list-style-type: none"> <li>1.a. Reduce electrical noise or move ZETA6104 away from noise source.</li> <li>1.b. Refer to Reducing Electrical Noise on page 34.</li> <li>2. Check wiring for opens, shorts, &amp; mis-wired connections.</li> </ol>										
LEDs	See Diagnostic LEDs above (page 34)											
Motion does not occur.	<ol style="list-style-type: none"> <li>1. Check LEDs.</li> <li>2. End-of-travel limits are active.</li> <li>3. P-CUT (Pulse cut-off) not grounded.</li> <li>4. Drive fault detected.</li> <li>5. Undervoltage (AC supply &lt; 95 VAC)</li> <li>6. Improper wiring.</li> <li>7. Load is jammed.</li> <li>8. No torque from motor.</li> </ol>	<ol style="list-style-type: none"> <li>1. See Diagnostic LEDs above.</li> <li>2.a. Move load off of limits or disable limits with the LH0 command.</li> <li>2.b. Set LSPOS to a value greater than LSNEG.</li> <li>3. Ground the P-CUT connection.</li> <li>4. Check status with TASXF command (see bit #4).</li> <li>5. Check status with TASXF command (see bit #2). Check AC supply.</li> <li>6. Check motor and end-of-travel limit connections.</li> <li>7. Remove power and clear jam.</li> <li>8. See problem: Torque, loss of.</li> </ol>										
Motor creeps at slow velocity in encoder mode (ENC1).	<ol style="list-style-type: none"> <li>1. Encoder direction opposite of motor direction.</li> <li>2. Encoder connected to wrong axis.</li> </ol>	<ol style="list-style-type: none"> <li>1. Switch encoder connections A+ &amp; A- with B+ &amp; B-.</li> <li>2. Check encoder wiring.</li> </ol>										
Programmable inputs not working.	<ol style="list-style-type: none"> <li>1. IN-P (input pull-up) not connected to a power supply.</li> <li>2. If external power supply is used, the grounds must be connected together.</li> <li>3. Improper wiring.</li> </ol>	<ol style="list-style-type: none"> <li>1.a. When inputs will be pulled down to 0V by an external device, connect IN-P to +5V supplied <u>or</u> to an external 5-24V positive supply (<u>but not to both</u>).</li> <li>1b. When inputs are pulled to 5-24V by an external device, connect IN-P to 0V.</li> <li>2. Connect external power supply's ground to ZETA6104's ground (GND).</li> <li>3. Check wiring for opens, shorts, and mis-wired connections.</li> </ol>										
Programmable outputs not working.	<ol style="list-style-type: none"> <li>1. Output connected such that it must source current (pull to positive voltage).</li> <li>2. OUT-P not connected to power source.</li> <li>3. If external power supply is used, the grounds must be connected together.</li> <li>4. Improper wiring.</li> </ol>	<ol style="list-style-type: none"> <li>1. Outputs are open-collector and can only sink current -- change wiring.</li> <li>2. Connect OUT-P to the +5V terminal <u>or</u> to an external supply of up to 24V.</li> <li>3. Connect the external power supply's ground to the ZETA6104's ground (GND).</li> <li>4. Check wiring for opens, shorts, and mis-wired connections.</li> </ol>										
Torque, loss of.	<ol style="list-style-type: none"> <li>1. Improper wiring.</li> <li>2. No power (POWER LED off).</li> <li>3. Overtemp, low voltage, or motor fault.</li> <li>4. Drive shutdown.</li> <li>5. Current standby mode enabled</li> </ol>	<ol style="list-style-type: none"> <li>1. Check wiring to the motor, as well as other system wiring.</li> <li>2. Check power connection (POWER LED should be on).</li> <li>3. Check LED status (see Diagnostic LEDs above).</li> <li>4. Enable drive with the DRIVE1 command.</li> <li>5. If more torque is needed at rest, disable standby mode (DAUTOS0 command)</li> </ol>										
Trigger, home, end-of-travel, or P-CUT inputs not working.	<ol style="list-style-type: none"> <li>1. If external power supply is used, the grounds must be connected together.</li> <li>2. Improper wiring.</li> </ol>	<ol style="list-style-type: none"> <li>1. Connect external power supply's ground to ZETA6104's ground (GND).</li> <li>2.a. Check wiring for opens, shorts, and mis-wired connections.</li> <li>2.b. When inputs are pulled down to 0V by an external device, connect AUX-P to +5V supplied <u>or</u> to an external +5-24V supply (<u>but not to both</u>).</li> <li>2.c. When inputs are pulled to 5-24V by external device, connect AUX-P to 0V.</li> <li>2.d. Make sure a 5-24V power source is connected to the V_I/O terminal.</li> </ol>										

# Troubleshooting Serial Communication Problems

---

## General Notes

- Power up your computer or terminal *BEFORE* you power up the ZETA6104.
- Make sure the serial interface is connected as instructed on page 8. Shield the cable to earth ground at one end only. The maximum RS-232 cable length is 50 feet (15.25 meters).
- RS-232: Handshaking must be disabled. Most software packages allow you to do this. You can also disable handshaking by jumpering some terminals on the computer's/terminal's serial port: connect RTS to CTS (usually pins 4 and 5) and connect DSR to DTR (usually pins 6 and 20).
- RS-485: Make sure the internal DIP switches and jumpers are configured as instructed on page 5.

## Test the Interface

1. Power up the computer or terminal and launch the terminal emulator.
2. Power up the ZETA6104. A power-up message (similar to the following) should be displayed, followed by a prompt (>):

```
*PARKER COMPUMOTOR 6104 — SINGLE AXIS INDEXER/DRIVE
*RP240 CONNECTED

>
```

3. Type "TREV" and press the ENTER key. (The TREV command reports the software revision.) The screen should now look as follows (if not, see Problem/Remedy table below).

```
*PARKER COMPUMOTOR 6104 — SINGLE AXIS INDEXER/DRIVE
*RP240 CONNECTED

>TREV
*TREV92-014630-01-4.7 6104
```

Problem	Remedy (based on the possible causes)
No Response	<ul style="list-style-type: none"><li>• COM port not enabled for 6000 language communication. If RS-232 connected to COM 1: issue "PORT1" and "DRPCHKØ" commands. If RS-232 connected to COM 2: issue "PORT2" and "DRPCHKØ" commands. If RS-485 connected to COM 2: issue "PORT2" and "DRPCHKØ" commands.</li><li>• RS-232: Echo may be disabled; enable with the ECHO1 command.</li><li>• If you are using an RS-232 connection between the host computer and the master ZETA6104 connected to multiple ZETA6104s in an RS-485 multi-drop, make sure the master ZETA6104 has these settings executed in the order given (you should place these settings in your power-up STARTP program):<ul style="list-style-type: none"><li>PORT1 (select RS-232 port, COM1, for configuration)</li><li>ECHO3 (echo to both COM ports)</li><li>PORT2 (select RS-485 port, COM2, for configuration)</li><li>ECHO2 (echo to the other COM port, COM1)</li></ul></li><li>• Faulty wiring. See instructions on page 8. RS-485: verify internal DIP switch and jumper settings on page 5. Also check for shorts or opens.</li><li>• Is the cable or computer/terminal bad? Here's a test:<ol style="list-style-type: none"><li>1. Disconnect the serial cable from the ZETA6104 end only.</li><li>2. Connect the cable's Rx and Tx lines together (this echoes the characters back to the host).</li><li>3. Issue the TREV command. If nothing happens, the cable or computer/terminal may be faulty.</li></ol></li><li>• The controller may be executing a program. Issue the !K command or the &lt;ctrl&gt;K command to kill the program.</li></ul>

**Problem/Remedy Table** (continued)

<b>Problem</b>	<b>Remedy (based on the possible causes)</b>
Garbled Characters	<ul style="list-style-type: none"><li>• Verify setup: 9600 baud (range is 19200-1200—see AutoBaud, page 4), 8 data bits, 1 stop bit, no parity; RS-232: Full duplex; RS-485: Half duplex (change internal jumper JU6 to position 1).</li><li>• RS-485: Transmission line not properly terminated. See page 5 for internal DIP switch and jumper settings. See page 8 for connections and calculating termination resistors (if not using the internal resistors via internal DIP switches).</li><li>• Faulty wiring. See instructions on page 8. RS-485: verify internal DIP switch and jumper settings on page 5. Also check for shorts or opens.</li></ul>
Double Characters	<ul style="list-style-type: none"><li>• Your terminal emulator is set to half-duplex; set it to full-duplex.</li></ul>

## Product Return Procedure

---

- Step 1 Obtain the serial number and the model number of the defective unit, and secure a purchase order number to cover repair costs in the event the unit is determined by the manufacturers to be out of warranty.
- Step 2 Before you return the unit, have someone from your organization with a technical understanding of the ZETA6104 system and its application include answers to the following questions:
- What is the extent of the failure/reason for return?
  - How long did it operate?
  - Did any other items fail at the same time?
  - What was happening when the unit failed (e.g., installing the unit, cycling power, starting other equipment, etc.)?
  - How was the product configured (in detail)?
  - Which, if any, cables were modified and how?
  - With what equipment is the unit interfaced?
  - What was the application?
  - What was the system environment (temperature, enclosure, spacing, contaminants, etc.)?
  - What upgrades, if any, are required (hardware, software, user guide)?
- Step 3 Call for return authorization. Refer to the *Technical Assistance* phone numbers provided on the inside front cover of this document. The support personnel will also provide shipping guidelines.



# Appendix A

## Resonance, Ringing & Damping – Discussion & Theory

In this appendix we will discuss resonance and ringing in step motors. This information will help you configure the ZETA6104's damping features—anti-resonance, active damping, and electronic viscosity.

All step motors have natural resonant frequencies, due to the nature of their mechanical construction. Internally, the rotor acts very similarly to a mass suspended on a spring—it can oscillate about its commanded position. Externally, the machine, mounting structure, and drive electronics can also be resonant, and interact with the motor. During a move, two types of problems can arise from these causes: resonance and ringing transients.

### Resonance (Steady State Response)

Resonance is a *steady state* phenomenon—it occurs when the motor's natural resonant frequencies are excited at particular velocities. It is not caused by transient commands that we give the motor. If you slowly increase your motor's speed from zero to 20 rps, for example, you may notice “rough” spots at certain speeds. The roughness is resonance; it is depicted in the next drawing.

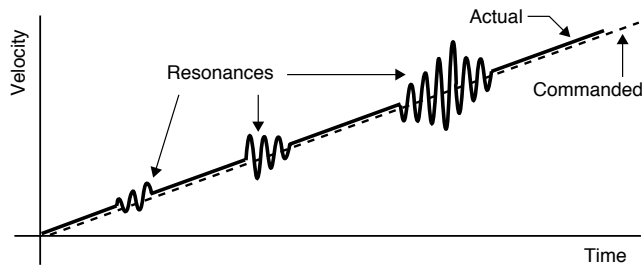

Instead of moving at the commanded velocity, the motor is oscillating between speeds faster and slower than commanded. This causes *error in rotor position*.

Resonance points can differ in intensity. The drawing shows a typical case—as motor speed increases, resonances of varying levels occur. Usually, the motor can accelerate through the resonance point, and run smoothly at a higher speed. However, if the resonance is extreme, the rotor can be so far out of position that it causes the motor to stall.

Resonance is affected by the load. Some loads are resonant, and can make motor resonance worse. Other loads can damp motor resonance. To solve resonance problems, system designers will sometimes attach a

damping load, such as an inertial damper, to the back of the motor. However, such a load has the unwanted effect of decreasing overall performance, and increasing system cost.

The ZETA6104 has internal electronics that can damp resonance, and *increase* system performance. No external devices are necessary.

### Ringing (Transient Response)

Inside a step motor, the rotor behaves like a mass on a spring, as mentioned above. When commanded to quickly accelerate to a given velocity, the rotor will “ring” about that velocity, oscillating back and forth. As shown in the next drawing, the ringing *decays*—grows smaller over time—and the rotor eventually settles at the commanded velocity.

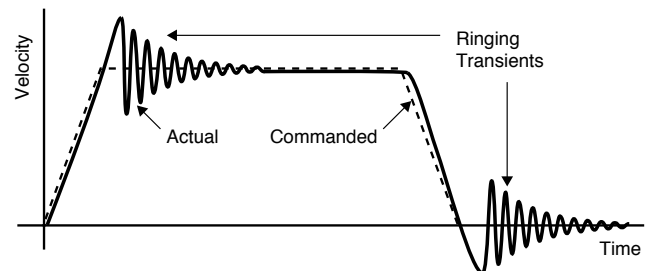

Notice that ringing can be caused both by accelerating or decelerating to a commanded velocity, and decelerating to a stop. In any of these cases, ringing causes *error in rotor position*.

Ringing is a *transient* phenomenon (unlike resonance, which occurs during steady state operations). It is a

response to a sudden change that we impose on the system, such as “Accelerate to Velocity” or “Stop.”

Several problems are associated with ringing. It can cause audible noise; the motor must have a margin of extra torque to overcome the ringing; and longer settling times can decrease throughput.

To eliminate these problems, system designers use damping to force the ringing to decay quickly. Inertial dampers have been used as components in passive damping methods. Accelerometers, encoders, and tachometers have been used as components in active damping methods. These devices can have the unwanted effect of limiting performance, adding complexity, and increasing cost.

The ZETA6104 has internal electronics that can damp ringing transients, and cause them to decay quickly. No external devices are necessary.

## Damping in the ZETA6104

The ZETA6104 has three different circuits that can damp resonance and ringing.

**Anti-Resonance** – General-purpose damping circuit. The ZETA6104 ships from the factory with anti-resonance enabled. No configuration is necessary. Anti-resonance provides aggressive and effective damping.

**Active Damping** – Extremely powerful damping circuit. The ZETA6104 ships from the factory with active damping disabled. You must use the DACTDP command to enable active damping and optimize it for a specific motor size and load (see procedure on page 26).

**Electronic Viscosity** – Provides passive damping at lower speeds. The ZETA6104 ships with electronic viscosity disabled. You must use the DELVIS command to enable electronic viscosity, and optimize it for a specific application (see procedure on page 29).

The first two damping circuits—anti-resonance and active damping—work at speeds greater than three revolutions per second (rps). Electronic viscosity works at speeds from rest up to three rps. The ZETA6104 will automatically switch between the damping circuits, based upon the motor’s speed. The next drawing shows the effective range of each circuit.

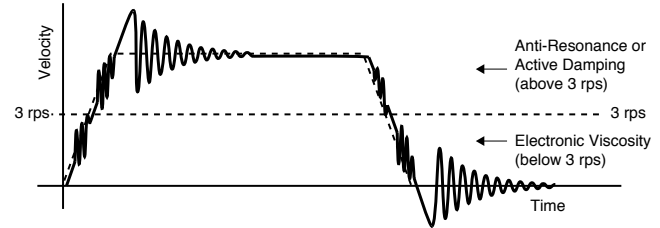

Above 3 rps, the ZETA6104 automatically enables either anti-resonance or active damping—but not both at the same time. They are mutually exclusive.

If active damping is set to zero (DACTDP0), the ZETA6104 enables anti-resonance. If the DACTDP command is set to any setting other than zero, the ZETA6104 enables active damping. This relationship is shown in the next drawing—notice in the drawing that anti-resonance can also be disabled with a command (DAREN0).

Differences between anti-resonance and active damping are described next; refer to the block diagram below.

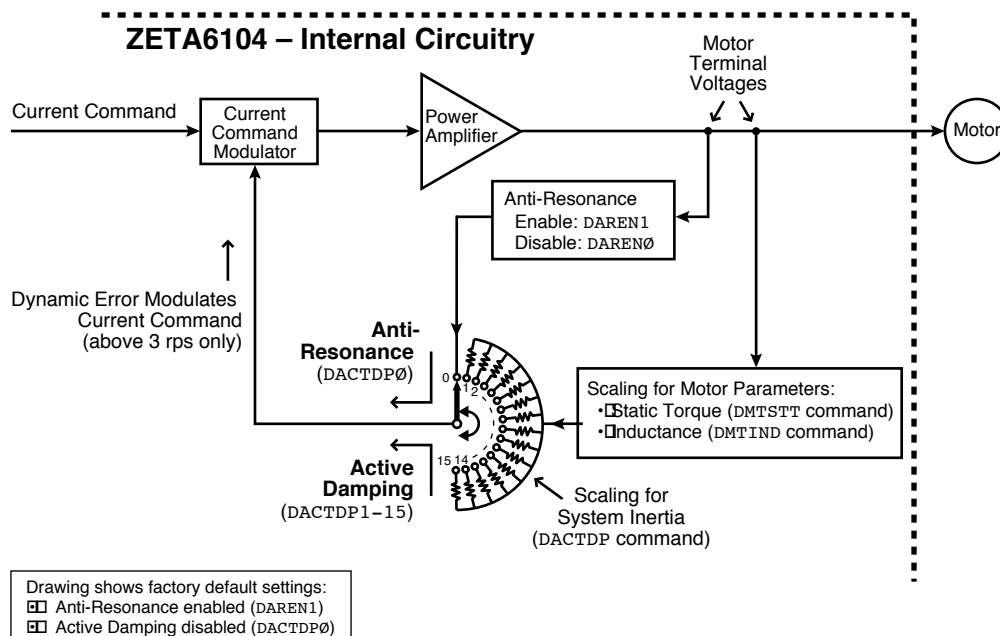

## Anti-Resonance (AR)

Anti-resonance monitors the ZETA6104's motor terminals, and looks at power exchange between the ZETA6104 and motor. From this, it extracts information about error in rotor position caused by resonance or ringing. It modifies the internal motor current command to correct for the error.

Anti-resonance is a general-purpose circuit. It corrects rotor position error, without knowledge about the system—whether the motor is large or small, or the system inertia is high or low. You cannot modify the circuit's gains, or customize it for a particular application—but, anti-resonance is easy to use. When enabled via the DAREN1 command, it works automatically.

## Active Damping (AD)

Active damping monitors the ZETA6104's motor terminals and, like anti-resonance, uses the same current command modulator to modify motor current.

Active damping uses a different method to extract information about rotor position error, however. The circuit's gains are adjustable—you can configure it for your particular system. The DMTIND and DMTSTT commands scale the circuit for motor inductance and static torque, respectively. The DACTDP command scales the circuit for system inertia.

The active damping circuit uses this information for two purposes:

1. It determines error in rotor position *very* accurately.
2. It adjusts the gains of its feedback loop, based upon how much inertia the system has, and how much torque the motor can produce.

If the rotor rings or vibrates, the active damping circuit will detect the corresponding error in rotor position. It will then modify the motor current command to damp the ringing.

DIP switches on top of the ZETA6104 set the amount of motor current during normal operations; this current is constant. To damp ringing, the active damping circuit can cause the ZETA6104 to produce up to twice as much current as is set by the DIP switches. The extra current is only applied during damping oscillations, and lasts a very brief time.

## Electronic Viscosity (EV)

The ZETA6104 uses closed-loop current control to develop and maintain precise currents in the motor phases. When EV is off, the current loops have a bandwidth of approximately 1000 Hz. Because this bandwidth is well beyond the knee of step motor speed-torque curves, the current loop dynamics do not limit the response of the motor.

EV monitors motor velocity, and turns on below 3 rps. It “detunes” the current loop compensation values and brings

the bandwidth down to 150 Hz. With this lower bandwidth, the drive electronics become “sluggish.” Ordinarily, when the rotor oscillates, it generates current in the motor's coils; but with EV's lower bandwidth, the drive's electronics impede the flow of current caused by oscillations.

The effect on the motor is as if there were a viscous drag on the rotor. At the end of a move, oscillations are damped, and the rotor quickly comes to rest. After accelerating or decelerating to velocities below 3 rps, the rotor quickly settles at the commanded velocity. During moves below 3 rps, EV significantly reduces low speed velocity ripple.

EV is a “passive” circuit. It imposes viscosity on the system, but has no feedback loop to monitor the effect of the viscosity. EV keeps the amount of viscosity the same, regardless of the response of the system.

You can adjust the amount of viscosity by using the DELVIS command. This allows you to tailor the circuit for different motor sizes and system inertias, and adapt it to your application.

## Recommendations

We recommend that you configure active damping and electronic viscosity. Even if you believe resonance and ringing will not cause problems in your system, you may find that the ZETA6104's damping circuits provide increased smoothness, reduced audible noise, and better performance. Refer to the configuration procedures beginning on page 26.

If you choose not to use active damping and electronic viscosity, at least use anti-resonance. The ZETA6104 is shipped from the factory with anti-resonance enabled (DAREN1).





# Appendix B

## Using Non-Compumotor Motors

We recommend that you use Compumotor motors with the ZETA6104. If you use a non-Compumotor motor, it must meet the following requirements:

- Inductance: 0.5 mH minimum; 5.0 to 50.0 mH recommended range; 80.0 mH maximum.
- A minimum of 500VDC high-pot insulation rating from phase-to-phase and phase-to-ground.
- The motor must be designed for use with a bipolar drive (no common center tap).
- The motor must not have riveted rotors or stators.
- Do not use solid rotor motors.
- Test all motors carefully. Verify that the motor temperature in your application is within the system limitations. *The motor manufacturer's maximum allowable motor case temperature must not be exceeded.* You should test the motor over a 2-to-3 hour period. Motors tend to have a long thermal time constant, but can still overheat, which results in motor damage.

**CAUTION:** Consult your motor vendor to verify that your motor meets the above specifications. If you have questions regarding the use of a non-Compumotor motor with the ZETA6104, consult your local Automation Technology Center (ATC) or distributor, or refer to the numbers listed under *Technical Assistance* on the inside front cover of this document.

### Wiring Configurations

Refer to the manufacturer's motor specification document to determine the motor's wiring configuration. You can also determine the wiring configuration with an ohmmeter using the procedures below (*4-Lead Motor*, *6-Lead Motor*, *8-Lead Motor*). Once you determine the correct motor wiring configuration, use the terminal connection diagram, shown at the end of this section, that applies to your configuration.

#### 4-Lead Motor

1. Label one motor lead **A+**.
2. Connect one lead of an ohmmeter to the **A+** lead and touch the other lead of the ohmmeter to the three remaining motor leads until you find the lead that creates continuity. Label this lead **A-**.
3. Label the two remaining leads **B+** and **B-**. *Verify that there is continuity between the **B+** and **B-** leads.*
4. Proceed to the *Terminal Connections* section below.

#### 6-Lead Motor

1. Determine, with an ohmmeter, which three of the six motor leads are common (one phase).
2. Label each one of these three motor leads **A**.
3. Using the ohmmeter, verify that the remaining three leads are common.

4. Label the remaining three leads **B**.
5. Set the ohmmeter range to the 100 ohm scale (approximately).
6. Connect the ohmmeter's negative lead to one of the motor leads labeled **A**. Alternately measure the resistance to the two remaining motor leads also labeled **A**. The resistance measurements will reflect one of the following two scenarios.  
**Scenario #1** — The resistance measurements to the two remaining motor leads are virtually identical. Label the two remaining motor leads **A+** and **A-**. Label the motor lead connected to the negative lead of the ohmmeter **A CENTER TAP** (this is the center tap lead for Phase A of the motor).  
**Scenario #2** — The resistance measurement to the second of the three motor leads measures 50% of the resistance measurement to the third of the three motor leads. Label the second motor lead **A CENTER TAP** (this is the center tap lead for Phase A of the motor). Label the third motor lead **A-**. Label the motor lead connected to the ohmmeter **A+**.
7. Repeat the procedure as outlined in step 6 for the three leads labeled **B** (**B CENTER TAP** is the center tap lead for Phase B of the motor).
8. Proceed to the *Terminal Connections* section below.

## 8-Lead Motor

Because of the complexity involved in phasing an 8-lead motor, you must refer to the manufacturer's motor specification document. You can configure the 8-lead motor in parallel or series. Using the manufacturer's specifications, label the motor leads as shown in the next drawing.

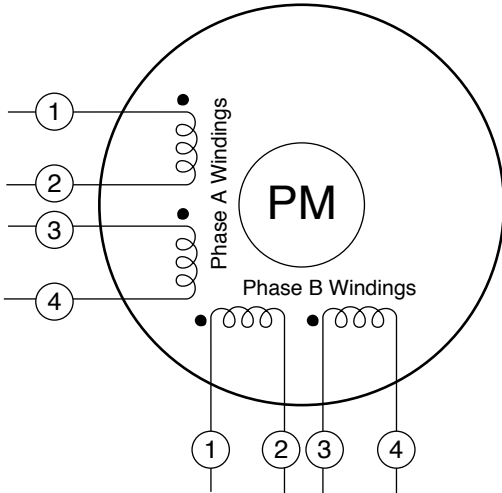

### Series Configuration Procedure:

1. Connect A2 & A3 together and relabel this common point **A CENTER TAP**.
2. Connect B2 & B3 together and relabel this common point **B CENTER TAP**.
3. Relabel the A1 lead **A+**.
4. Relabel the A4 lead **A-**.
5. Relabel the B1 lead **B+**.
6. Relabel the B4 lead **B-**.
7. Proceed to the *Terminal Connections* section below.

### Parallel Configuration Procedure:

1. Connect motor leads A1 & A3 together and relabel this common point **A+**.
2. Connect motor leads A2 & A4 together and relabel this common point **A-**.
3. Connect motor leads B1 & B3 together and relabel this common point **B+**.
4. Connect motor leads B2 & B4 together and relabel this common point **B-**.
5. Proceed to the *Terminal Connections* section below.

## Terminal Connections

After you determine the motor's wiring configuration, connect the motor leads to the ZETA6104's 9-pin **MOTOR** connector according to the appropriate diagram below.

### 4-Lead Motor

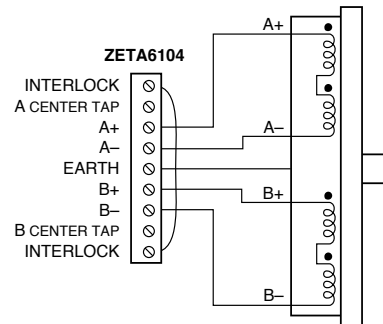

### 6-Lead Motor

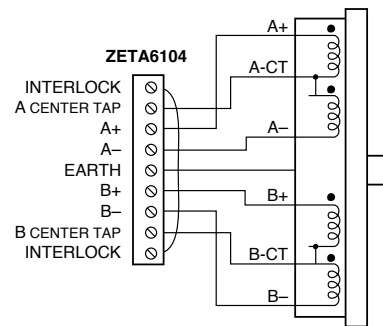

### 8-Lead Motor Series

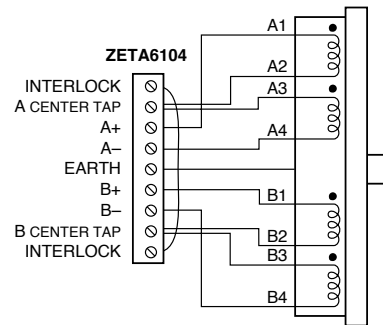

### 8-Lead Motor Parallel

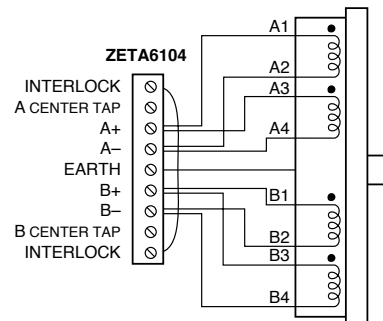

## Direction of Motor Rotation

The procedures above do not determine the direction of motor shaft rotation. To find out which direction the shaft turns, you must power up your system and command motion. If the shaft turns in the opposite direction than you desire, exchange the motor leads connected to **A+** and **A-** to reverse the direction of rotation.

### CAUTION

Motor shaft rotation may be opposite than you expect. Do not connect a load to the shaft until you first determine the direction of shaft rotation.

## Setting Motor Current

To set motor current for a non-Compumotor motor, refer to the formulas below that correspond to your motor (4-lead, 6-lead, 8-lead) and use the current settings shown on page 4 to set the motor's current.

### WARNING

Do not connect or disconnect the motor with the power on. Doing so will damage the contacts of the motor connector and may cause personal injury.

### 4-Lead Motors

If you use a 4-lead motor, the manufacturer's current specification will translate directly to the values shown for current in the DIP switch table on page 4.

### 6-Lead Motors

If you use a 6-lead motor, and the manufacturer specifies the motor current as a bipolar rating, you can use the DIP switch table's current settings directly (no conversion) to set motor current.

If the manufacturer specifies the motor current as a unipolar rating, use the following formula to convert the unipolar current rating to the correct bipolar rating:

$$\text{Unipolar Current} * 0.707 = \text{Bipolar Current}$$

After you make the conversion, use the values shown for current in the DIP switch table to set the motor current.

### 8-Lead Motors

Manufacturers generally use either a unipolar rating or a bipolar rating for motor current in 8-lead motors.

**Unipolar Rating:** If the manufacturer specifies the motor current as a unipolar rating:

- Use the following formula to convert the unipolar current rating to the correct bipolar rating:

$$\text{Unipolar Current} * 0.707 = \text{Bipolar Current}$$

- If you wire the motor in **series**, use the DIP switch table's current settings and the converted value to set the motor current.
- If you wire the motor in **parallel**, you must **double** the converted value and use the DIP switch table's current settings to set the motor current.

**Bipolar Rating:** If the manufacturer specifies the motor current as a bipolar series rating:

- If you wire the motor in **series**, use the DIP switch table's current settings directly.
- If you wire the motor in **parallel**, you must double the manufacturer's rating and then use the DIP switch table's current settings to set the motor current.

If you have any questions about setting motor current, consult your local Automation Technology Center (ATC) or distributor, or refer to the numbers listed under *Technical Assistance* on the inside front cover of this document.



# Appendix C

## LVD Installation Instructions

For more information about the Low Voltage Directive (LVD), see 73/23/EEC and 93/68/EEC, published by the European Economic Community (EEC).

### Environmental Conditions

**Pollution Degree:** The ZETA6104 is designed for pollution degree 2.

**Installation Category:** The ZETA6104 is designed for installation category II.

### Electrical

#### Connecting & Disconnecting Power Mains

The ZETA6104's protective earth connection is provided through its make-first/break-last earth terminal on the power mains connector. You must reliably earth the ZETA6104's protective earth connection.

#### Using an Isolation Transformer

The ZETA6104's mains voltage is limited to 120 VAC nominal. If your mains voltage is higher, use an isolation transformer located between the power mains and the ZETA6104. Your isolation transformer should be insulated to ~2300V rms.

Do not interrupt the protective earth conductor between the source mains and the isolation transformer's secondary. The core of the isolation transformer and the drive's protective conductor terminal must *both* be connected to the mains protective earth conductor.

**CAUTION** — Do not use an autotransformer.

#### Adding Line Fuses

Line fuses need to be added to protect the transformer and associated wiring. If the live wire cannot be readily identified, fuse both phase conductors. The value of fuse required is given by:  $(1.5 \times VA)/(\text{supply volts})$  [amps]

Fuse types should be anti-surge HBC.



**WARNING** — Safety Ground (Earth Ground) should **never** be fused.

### Providing a Protective Earth Connection for Motors

You must provide a connection from the motor to a reliable protective earth contact point. This connection provides a protective earth for the motor, and is in addition to the earth connection provided by the drain wire in the motor's power cable. The motor's protective earth connection is important for safety reasons, and must not be omitted.

Make connections according to the diagram and instructions below:

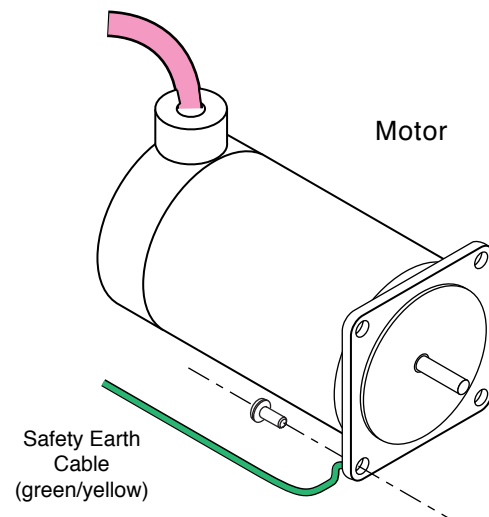

1. Use a spade lug in combination with a star washer and mounting bolt to make good contact with the bare metal surface of the motor's mounting flange.
2. Use a green and yellow striped wire to make the connection between the motor and earth. Wire gauge must be no thinner than the current carrying wire in the motor's power cable.
3. Resistance between the motor and earth must be no greater than 0.1  $\Omega$ . Use thicker gauge wire if the resistance is too high.

## Mechanical

**Installing in an Enclosure:** The ZETA6104 must be installed within an enclosure. The enclosure's interior must not be accessible to the operator. The enclosure should be opened only by skilled or trained service personnel.

## Servicing the ZETA6104

**Changing Firmware:** Only skilled or trained personnel should change firmware.

**Changing Batteries:** The ZETA6104 contains a replaceable lithium battery, of type Duracell DL2450, or Sanyo CR2450, or equivalent. Only skilled or trained personnel should change batteries. Dispose of batteries in accordance with local regulations.

**Do Not Replace Fuses:** The ZETA6104 has no fuses designed to be replaced by the user. Fuse failure indicates that other components have also failed. Fuses and other components should only be replaced by Compumotor or its designated repair facilities.

## Thermal Safety









**The Motor May Be HOT:** The motor may reach high temperatures during normal operations, and may remain hot after power is removed.

## Sonic Pressure

**High Sound Level:** The sound level from some large frame step motors (NEMA 34, NEMA 42, and larger) may exceed 85 dBA. Actual sound level is application dependent, and varies with motor loads and mounting conditions. Measure the sound level in your application; if it exceeds 85 dBA, install the motor in an enclosure to provide sound baffling, or provide ear protection for personnel.

## Table of Graphic Symbols & Warnings

The following symbols may appear in this manual, and may be affixed to the products discussed in this manual.

Symbol	Description
	Earth Terminal
	Protective Conductor Terminal
	Frame or Chassis Terminal
	Equipotentiality
	Caution, Risk of Electric Shock
	Caution, Refer to Accompanying Text
	Hot Surface
	Recycle Battery

# Appendix D

## EMC Installation Guidelines

### General Product Philosophy

The ZETA6104 was not designed originally for EMC compliance. Therefore, it will require specific measures to be taken during installation. The ultimate responsibility for ensuring that the EMC requirements are met rests with the systems builder.

It is important to remember that for specific installations, the full protection requirements of the EMC Directive 89/336/EEC need to be met before the system is put into service. This must be verified either by inspection or by testing. The following EMC installation instructions are intended to assist in ensuring that the requirements of the EMC directive are met. It may be necessary to take additional measures in certain circumstances and at specific locations.

It should be stressed that although these recommendations are based on expertise acquired during tests carried out on the ZETA6104, it is impossible for Compumotor to guarantee the compliance of any particular installation. This will be strongly influenced by the physical and electrical details of the installation and the performance of other system components. Nevertheless, it is important to follow *all* the installation instructions if an adequate level of compliance is to be achieved.

### Safety Considerations

The ZETA6104 is intended for installation according to the appropriate safety procedures including those laid down by the local supply authority regulations. The recommendations provided are based on the requirements of the Low Voltage Directive and specifically on EN60204. It should be remembered that safety must never be compromised for the purpose of achieving EMC compliance. Therefore in the event of a conflict occurring between the safety regulations and the following recommendations, *the safety regulations always take precedence.*

### Ferrite Absorbers and P-Clips

#### Ferrite Absorber Specifications

The absorbers described in these installation recommendations are made from a low-grade ferrite material which has high losses at radio frequencies. They therefore act like a high impedance in this waveband.

The recommended components are produced by Parker Chomerics (617-935-4850) and are suitable for use with cable having an outside diameter up to 10-13mm. The specification is as follows:

Chomerics part #	83-10-M248-1000	83-10-A637-1000
Outside diameter	17.5mm	28.5mm
Inside diameter	10.7mm	13.77mm
Length	28.5mm	28.57mm
Impedance at 25MHz	80Ω	135Ω
Impedance at 100MHz	120Ω	210Ω
Curie temperature	130°C	130°C

*(the device should not be operated near this temperature)*

### Handling & Installing Ferrite Absorbers

Take care when handling the absorbers—they can shatter if dropped on a hard surface. For this reason the suggested method of installation is to use a short length of 19mm diameter heat-shrink sleeving (see Figure 1). This gives a degree of physical protection while the cable is being installed. The sleeving should have a shrink ratio of at least 2.5:1. Cable ties may be used as an alternative, however they give no physical protection to the absorber.

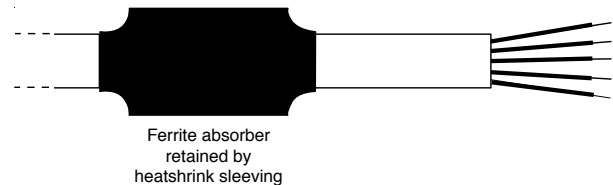

Figure 1. Ferrite Sleeve Installation

### P-Clip Installation Details

The function of the P-clip is to provide a 360-degree metallic contact and thus a convenient means of ensuring a proper R.F. ground. When dealing with EMI issues, it is important to remember that continuity, a DC connection, does not at all speak to the integrity of an AC (high-frequency) connection. High-Frequency bonding typically involves wide, flat cabling to establish a suitable system ground. When applied properly, the P-clip has been shown to give an adequate high-frequency contact.

When installing a P-clip (see Figure 2), install as close to the cable end as possible, provided a suitable ground, backplane, earth stud or bus bar is accessible, (this may mean removing the paint from a cabinet or panel). Remove only the outer (vinyl) jacket of the braided screen

cable (this allows the braid to continue to the cable connector), be careful not to damage the braid. Snap the P-clip over the exposed braid, and adjust for a tight fit. Secure the clip to the designated ground with a machine screw and lock washer. The use of brass or other inert conductive metal P-clip is recommended. Cover any exposed bare metal with petroleum jelly to resist corrosion.

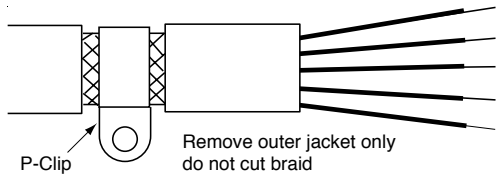

Figure 2. P-Clip Installation

## Installation

### External Enclosure

#### Introduction

The measures described in this section are primarily for the purpose of controlling conducted emissions. To control radiated emissions, all drive and control systems must be installed in a steel equipment cabinet which will give adequate screening against radiated emissions. This external enclosure is also required for safety reasons. There must be no user access while the equipment is operating. This is usually achieved by fitting an isolator switch to the door assembly.

To achieve adequate screening of radiated emissions, all panels of the enclosure must be bonded to a central earth point. The enclosure may also contain other equipment and the EMC requirements of these must be considered during installation. Always ensure that drives and controllers are mounted in such a way that there is adequate ventilation.

Preparing the ZETA6104: The ZETA6104 must be mounted to a conductive panel. Before mounting the ZETA6104, remove the paint from the rear face of the mounting hole that will be closest to the input filter location as shown in Figure 3 below, and if necessary from the corresponding area on the rear panel of the enclosure. This is to guarantee a good high-frequency connection between the drive case and the cabinet. After mounting the unit use petroleum jelly on the exposed metal to minimize the risk of future corrosion.

### Filtering the AC Supply

#### Introduction

These recommendations are based on the use of proprietary screen filter units which are readily available. However, the full EMC test includes a simulated lightning strike which will damage the filter unless adequate surge suppression devices are fitted. These are not normally incorporated into commercial filters since the lightning strike test can be destructive. This test is normally carried out on the overall system and not on individual components; therefore, the surge protection should be provided at the system boundary.

A filter must be installed between the incoming AC supply and the input to the drive. The manufacturer's part numbers for suitable filters are:

#### Corcom 10VV1

Corcom World Headquarters  
Phone: 847-680-7400  
Fax: 847-680-8169

#### Schaffner FN670-10/06

Schaffner EMC Inc.  
Phone: 201-379-7778  
Fax: 201-379-1151

Mount the filter within 2 inches (50mm) of the ZETA6104 as shown in Figure 3 below. Ensure that there is no paint on the mounting panel under the filter mounting lugs—it is vital that there is good large-area contact between the filter and the panel.

Connect the incoming AC supply cable to the push-on terminals on the filter, with the earth lead connected to a local earth stud, bus bar or metal back-plane. Route the supply cable so that it runs close to the walls of the enclosure. Connect the earth terminal on the filter case to the earth stud.

Fit a ferrite absorber over the cable before wiring the filter output terminals to the AC input on the drive. Locate the absorber as close as possible to the drive using heat-shrink sleeving (see Figure 1 above). Take the ZETA6104 earth connection from the same stud that retains the filter case earth, as shown in Figure 3 below.

### Motor Connections

#### Compumotor Motors

Parker Compumotor ZETA Series step motor systems ship with motors that do not incorporate the use of a braided screen for the control of conducted emissions. Therefore, when used in installations where the motor cable is not within earthed conduit the entire length of travel, the standard motor cable should not be used.

At the drive end of the motor cable, fit a ferrite absorber over the cable before wiring to the motor connector (it may be necessary to remove the existing connector). Locate the absorber as close as possible to the connector using heat-shrink sleeving.

For motors with exposed cabling (not within earthed conduit), follow the guidelines below:

- Removable Cabling: Remove the motor cable from the standard motor, and replace with a suitable cable described below, see *Motor Cables*.
- Permanent Cabling: Cut off cable in excess of approximately 4 inches (10 cm). Configure the motor for series or parallel operation and attach a suitable braided screen cable to the motor, see *Motor Cables* below.

Termination of the braid shield at the motor must be made using a 360° bond to the motor body, and this may be achieved by using a suitable clamp. Many stepper motors are designed to accommodate an appropriate terminal gland which can be used for this purpose. If this is not the case, P-clip the braid to the rear end bell of the motor housing, as shown in Figure 4. This will not only provide a good high-frequency bond, but strain relief as well.



At the drive end, run the motor cable down to the mounting panel, expose a short length of braiding and anchor to the panel with a P-clip. The ZETA Series require a safety earth connection to the motor (see green and yellow striped wire in Figure 4) — take this from the stud or bus bar. Run the safety earth lead alongside the motor lead. Note that the motor cable should be kept away from I/O cables carrying control signals.

### Motor Cables

For 10 foot (replacement) cable lengths, use 4-core 1mm<sup>2</sup> (AWG 18) (SWG 20) braided screen cable for the motor connections on the ZETA6104. At the drive end, fit a ferrite absorber over the cable before wiring to the motor connector. Locate the absorber as close as possible to the connector using heat-shrink sleeving.

All after-market motor connections must be made using a high quality braided-screen cable. Cables using a metallized plastic foil for an earth screen are unsuitable and provide very little screening. Terminating to the screen in a mechanically stable manner is difficult because the screen itself is comparatively fragile — bending it in a tight radius can seriously affect the screening performance.

There must be no break in the 360° coverage that the screen provides around the cable conductors. If a connector must be used it should retain the 360° coverage, possibly by the use of an additional metallic casing where it passes through the bulkhead of the enclosure. The cable screen must *not* be connected to the cabinet at the point of entry. Its function is to return high-frequency chopping current back to the drive or controller. This may require mounting the connector on a sub-panel insulated from the main cabinet, or using a connector having an internal screen which is insulated from the connector housing.

Within the cabinet itself, all the motor cables should lie in the same trunking as far as possible. They must be kept separate from any low-level control signal cables. This applies particularly where the control cables are unscreened and run close to the drive or other sources of electrical noise.

### Motor Feedback Cables

Feedback devices such as encoders, tachometers and Hall effect sensors also require the use of high-quality braided screen cable. If it is necessary to replace the standard feedback cable, select a braided screen cable that matches the gauge of the device's original cable and attach as close to the transducer as possible. Avoid complex and bulky connections that can cause degradation in feedback signal quality. If possible, use in-line cable splicing techniques, and cover the splice point with heat-shrink tubing. Remove a section of the braided shield cable's insulation to expose the braid, and tie the braid to earth using the same P-clip 360° bond as shown in Figure 2. Differential signals should use twisted pair cable to minimize magnetic coupling. At the receiving end, fit a ferrite absorber over the feedback cable before wiring the connector, then P-clip the braid to a suitable ground (metal back-plane of drive mounting panel, or earth point of device that receives the feedback)— see Figure 3.

### Step Motors

It is preferable to use motors with screw terminations whenever possible. If flying-lead motors are used, it is important that the unscreened leads are converted into a braided-screen cable within 4 inches (10cm) of the motor body. A separate terminal box may be used for this purpose but the braided cable screen must be properly strapped to the motor body, as shown in Figure 4. Motors fitted with terminal boxes also allow local selection of series or parallel connection, reducing the cost of the cable running back to the drive.

### Control Signal Connections

High-quality braided screen cable should be used for control connections. In the case of the ZETA6104, which has differential step-direction inputs, it is preferable to use a cable with twisted pairs to minimize magnetic coupling. No connection is made to the cable screen at the drive itself. Fit a ferrite absorber close to the I/O connector and run the cable down to the mounting panel as shown in Figure 3. Expose a short length of the braided screen and anchor to the panel with a P-clip.

The level at which the I/O operates means that the signals are unlikely to meet EMC immunity requirements if taken outside the enclosure without proper screening.

50-Pin Ribbon Cable: It is recommended when using the 50-Pin Ribbon Cable I/O found on the ZETA6104 that a terminal break out box such as the VM50 be used (see Figure 3). Mount the VM50 close to the ZETA6104, keeping the ribbon cable as short as possible. Bundle any excess ribbon cable and secure close to a panel wall. Individual I/O points will require the use of individually shielded cable runs, with braids bonded to the panel (close to VM50) with a P-clip.

Communications: In applications that require serial communications with the ZETA6104, take special care to assure proper wiring practices are utilized. Good quality braided screen cable should be used for the communication cabling. In the specific case of differential mode (RS-485) protocol, twisted pair cable shall be used. No connection is made to the cable screen at the drive itself. Fit a ferrite absorber close to the communications connector and run the cable down to the mounting panel as shown in Figure 3. Expose a short length of the braided screen and anchor to the panel with a P-clip. Avoid routing communication cables near high power lines, and sources of high energy impulses.

**Remember** to route control signal connections well away (at least 8 inches) from relays and contactors. Control wiring should not be laid parallel to power or motor cables and should only cross the path of these cables at right angles. Bear in mind that control cables connected to other equipment within the enclosure may interfere with the controller, particularly if they have come from outside the cabinet. Take particular care when connecting external equipment with the cabinet door open, for instance a computer or terminal; static discharge may cause damage to unprotected inputs.

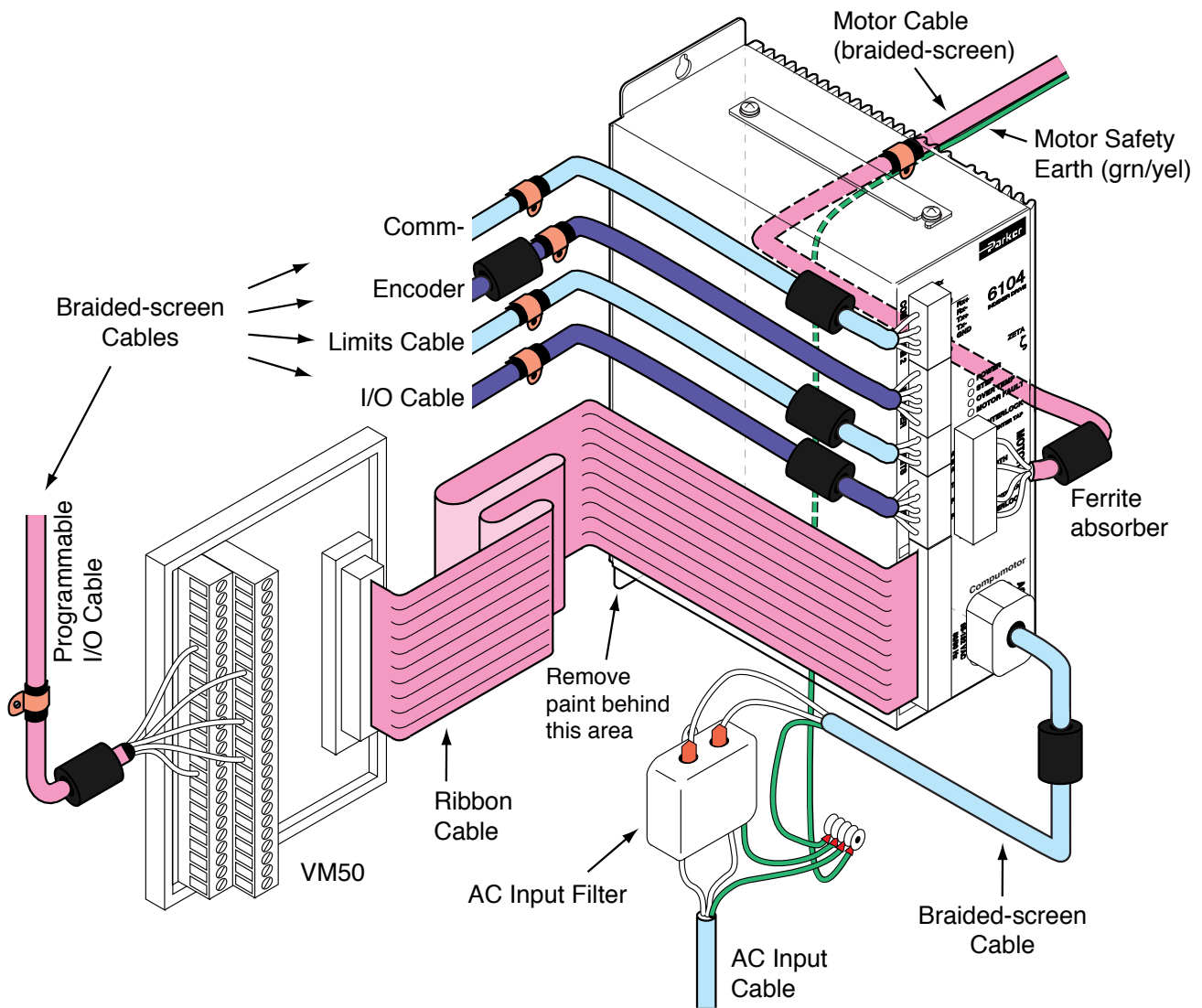

Figure 3. EMC Connections for ZETA6104

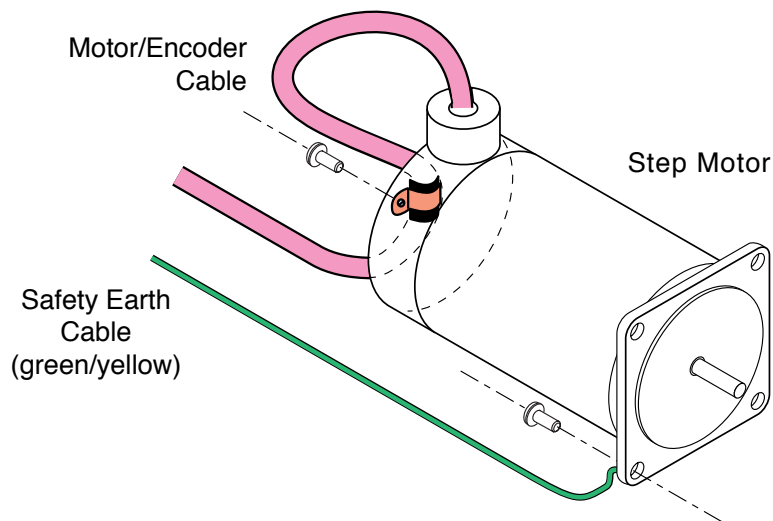
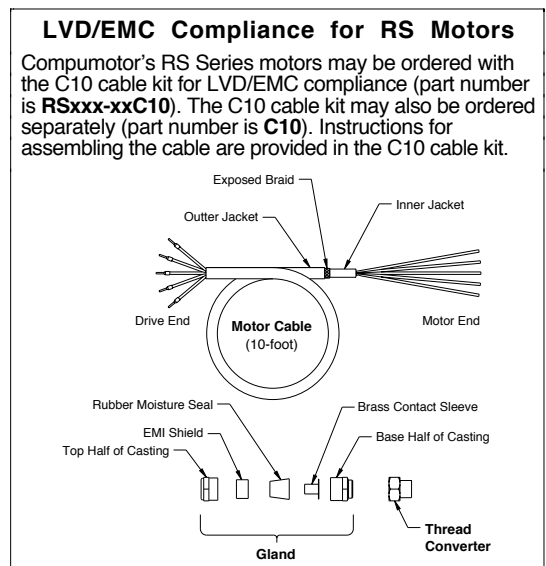

Figure 4. EMC Connections for Step Motor – P-Clip, Safety Earth



# INDEX

3rd harmonic 23  
4-lead motor (non-Compumotor) wiring 43  
6-lead motor (non-Compumotor) wiring 43  
5V power supply  
  connections (see page for connection  
  item, like P-CUT, Encoder, etc.)  
  load limit 3  
8-lead motor (non-Compumotor) wiring 44  
6000user@cmotor.com (e-mail address) i

## A

AC input power connections & specs  
  18  
acceleration range 3  
accuracy  
  stepping 3  
  velocity 3  
active damping  
  configuration procedure 26  
  definition 41  
active levels (see polarity)  
ADDR (auto addressing) command 4  
address  
  auto-address multiple units 4  
  DIP switch selection 4  
air-flow space, minimum 6  
airborne contaminants 6  
anti-resonance  
  configuring 26  
  definition 41  
assumptions (skills & knowledge  
  required for installation) i  
auto addressing multiple units 4  
auto baud procedure 4  
auto current standby 9, 25

## B

balance 22  
battery, changing 48  
baud rate 3  
  automatic selection 4  
BBS (bulletin board service) 34  
BCD input via thumbwheels 17  
bearings, zeta & OS/RS motors 3  
bias resistors  
  calculating 8  
  DIP switch selection 5  
bipolar current 45

## C

cables  
  I/O, extending 19  
  motor 9  
  serial communication (max. length)  
  36  
calculating bias & termination resistors  
  8  
change summary i  
circuit drawings (see back cover of  
  manual, and “schematics, internal”)  
COM 2 port function 5  
common problems & solutions 35  
communication  
  Motion Architect 32  
  serial (see serial communication)  
  terminal emulation 20  
  troubleshooting 36  
conduit 2, 19  
configuration  
  active damping 26  
  address 4  
  anti-resonance 26  
  autobaud 4  
  bias resistor selection 5  
  COM 2 port function 5  
  electronic viscosity 29  
  inductance 27  
  matching the ZETA6104 to the  
  motor 22  
  motor current 4  
  recording 30  
  RS-485 setup 5  
  serial communication on COM 2 5  
  static torque 27  
  termination resistor selection 5  
connections  
  computer 8, 20  
  daisy-chain 8  
  EMC-compliance guidelines 49  
  encoder 12  
  end-of-travel limit inputs 11  
  grounding 7  
  home limit inputs 11  
  lengthening cables 19  
  LVD-compliant installation 47  
  motor 9  
    non-Compumotor 44, 45  
    wiring options 9, 10  
multi-drop 8

PLC inputs 16  
PLC outputs 15  
power (VAC) input 18  
programmable inputs 15  
programmable outputs 16  
pulse cut-off input (P-CUT) 7  
RP240 18  
RS-232C 8  
RS-485 8  
  terminal 8, 20  
  testing 20, 21  
  thumbwheels 17  
  trigger inputs 13  
  VM50 screw terminal adaptor 14  
contaminants 6  
cooling the motor 25  
coupling the motor to the load 25  
current, motor  
  automatic reduction (DAUTOS) 9,  
  25  
  bipolar rating 45  
  selecting 4  
    non-Compumotor motors 45  
  unipolar rating 45  
  waveform 23

## D

DACTDP (active damping) command 27  
  part of set-up program 30  
daisy-chain connections 8  
damping  
  configuration  
    active damping 26  
    anti-resonance 26  
    electronic viscosity 29  
  defined 40  
DAREN (anti-resonance) command 40  
  part of set-up program 30  
DAUTOS command 9, 25  
  part of set-up program 30  
DDE6000™ 32  
DELVIS (electronic viscosity)  
  command 29  
  part of set-up program 30  
device address (see address)  
diagnostic LEDs 34  
dimensions  
  motor 24  
  ZETA6104 6

- DIP switch settings
  - address 4
  - autobaud feature 4
  - bias & termination resistors 5
  - motor current 4
- disassembling the ZETA6104 5
- DMTIND (inductance) command 27
  - part of setup program 30
- DMTSTT (static torque) command 27
  - part of set-up program 30
- drive resolution 35
- drive/motor matching 22
- DRPCHK command 18
  - part of set-up program 30
- DWAVEF (waveform) command 23
  - part of set-up program 30

## E

- e-mail address for feedback i
- ECHO 30
- electrical noise 2, 34
  - EMC installation guidelines 49
  - suppressing 19
- electronic viscosity
  - configuration procedure 29
  - definition 41
- EMC installation guidelines 49
- emergency stop (pulse cut-off) switch 7
- encoder
  - connections 12
    - testing 21
  - resolution 35
  - specifications 12
- end-of-travel limits
  - connections 11
  - testing 21
- environmental specifications 3, 6
- extending cables
  - I/O 19
  - motor 9
  - RS-232C 36

## F-H

- factory configuration 4
  - default set-up command values 30
- faults (see LEDs, diagnostic)
- FAX number for technical support 34
- feedback, e-mail address i
- ferrite absorbers 49
- filtering the AC input supply 50
- firmware, changing 48
- fuses
  - adding line fuses 47
  - internal (do not replace!) 48
- grounding 2
  - EMC guidelines 49
  - system diagram 7
- handshaking, disabling 36
- hard limits (see end-of-travel limits)
- harmonic, waveform 23
- HCMOS-compatible switching levels 3
- heat 3
- helpful resources (publications) i
- home limit input
  - connections & specs 11
  - testing 21
- humidity 3

## I

- I/O cabling 19
- inductance, configuration (DMTIND) 27
- inductive load, connecting outputs to 16
- inertia, and active damping 27
- information label 30
- inputs
  - encoder 12
  - end-of-travel limits 11
    - problems 35
  - general-purpose programmable 14
    - problems 35
  - home limit 11
    - problems 35
  - P-CUT 7
    - problems 35
  - power (AC) 18
  - serial communication (see serial communication)
  - suppressing noise 19
  - testing 21
  - trigger 13
    - problems 35
- installation
  - connections (see connections)
  - DIP switch settings (see DIP switch settings)
  - EMC guidelines 49
  - LVD instructions 47
  - mounting (see mounting)
  - precautions 2
  - process overview 2
  - test 20
  - interlock jumper 9, 34

## J-L

- jumper settings 5
- LEDs, diagnostic 18, 34
- limit input connections 11
- line fuses, adding 47
- load, coupling 25
- LVD installation instructions 47

## M

- magnetic label 30
- matching, ZETA6104 to motor 22
- minimum air-flow space 6
- motion algorithm update rate 3
- Motion Architect 32
- Motion Builder™ 32
- Motion Toolbox™ 32
- motor
  - connections 9
    - non-Compumotor 44, 45
    - protective earth 47, 50
    - series or parallel 9, 10
  - cooling 25
  - coupling 25
  - current selection 4
    - non-Compumotor motors 45
  - current standby mode 9, 25
  - dimensions 24
  - fault 34
  - modifying 24
  - motor/drive matching 22

- mounting 24
  - peak power requirements 18
  - specifications 3
  - speed/torque curves 10
  - thermal safety 48

## mounting

- EMC compliant 50
- motor 24
- ZETA6104 chassis 6
- multi-drop
  - connections 8
  - internal configuration 5

## N-O

- National Electric Code Handbook i
- negative-travel limits 11
- noise, electrical 2, 34
  - suppression on I/O cables 19
- offset, phase 22
- opening the ZETA6104 5
- outputs
  - general-purpose programmable 14
    - problems 35
  - OUT-A 14
  - testing 21
- over temp fault 34

## P-Q

- P-clips 49
- P-CUT (pulse cut-off) input
  - connections & specs 7
- parallel motor connection 9, 10
- peak power requirements 18
- performance specifications 3
- phase balance 22
- phase offset 22
- pin outs (see also back cover)
  - encoder connector 12
  - limits connector 11
  - motor connector 9
  - programmable inputs 14
  - programmable outputs 14
- PLC connections 15
- polarity
  - commanded direction 35
  - end-of-travel limit inputs 11
  - home input 11
  - programmable inputs 14
  - programmable outputs 14
  - trigger inputs 13
- PORT command 18
  - COM 2 function 5
  - part of set-up program 30
- position range 3
- positive-travel limits 11
- potentiometers 22
- power supply
  - 5V load limit 3
  - AC input connections & specs 18
  - AC input, filtering 50
  - for P-CUT, limit inputs, & trigger inputs 7, 11, 13
  - for programmable inputs & outputs 14
- power up auto test 4
- pre-installation changes 4

- precautions
  - installation 2
  - mounting 6
- process of installation 2
- product return procedure 37
- programmable I/O
  - connections & specs 14
  - testing 21
- programming tools available 32
- pulse cut-off (P-CUT)
  - testing 21

## R

- reference documentation i
- removing the ZETA6104 chassis 5
- resistors, termination/bias
  - calculating 8
  - selecting 5
- resolution
  - drive 35
  - encoder 12, 35
- resonance 39
- return procedure 37
- ringing 39
- rotor inertia, zeta & OS/RS motors 3
- RP240, connections 18
  - testing 21
- RS-232C (see serial communication)
- RS-485 (see serial communication)

## S

- safety 2
- safety stops (see end-of-travel limits)
- schematics, internal (see also back cover)
  - encoder inputs 12
  - limit inputs 11
  - P-CUT input 7
  - programmable inputs and outputs 14
  - trigger inputs 13
- serial communication
  - RS-232C
    - configuration 5
    - connections 8
    - daisy-chain connections 8
    - disable handshaking 36
    - specifications 3
    - troubleshooting 36
  - RS-485
    - configuration 5
    - connections 8
    - disable handshaking 36
    - multi-drop connections 8
    - resistor calculation 8
    - RP240 connections 18
    - specifications 3
    - troubleshooting 36
- series motor connection 9, 10
- set-up commands 30
- set-up program 30
- shielding 2
  - EMC guidelines 49
  - I/O cables 19
- ship kit 2
- sinking input device, connecting to 16

- sinking output device, connecting to 13, 15
- software, update from BBS 34
- sonic pressure 48
- sourcing input device, connecting to 16
- sourcing output device, connecting to 13, 15
- specifications
  - motor 3
    - peak power requirements 18
    - speed/torque curves 10
  - overall list of (see also back cover)
- speed/torque curves, ZETA & OS/RS motors 10
- startup (STARTP) program 30
- static torque
  - configuration (DMTSTT) 27
  - ZETA & OS/RS motor specs 3
- status commands (see also back cover, and test on page 20)
  - axis (see TASF command)
  - limit switches (see TLIM command)
  - motor faults (see TASXF command)
- P-CUT input (see TINOF command, bit 6)
- programmable inputs (see TIN command)
- programmable outputs (see TOUT command)
- trigger inputs (see TIN command)
- status LEDs 18, 34
- stepping accuracy 3
- support software available 32

## T

- technical assistance (see inside of front cover, and HELP command)
- temperature range 3
- terminal emulation, set up 20
- termination resistors
  - calculating 8
  - DIP switch selection 5
- test
  - system installation 20
  - test panel (Motion Architect) 34
  - TEST program 34
- thermal safety 48
- third harmonic 23
- thumbwheel connections 17
- transformer, isolating 47
- travel limits 11
- trigger inputs
  - connections 13
  - testing 21
- troubleshooting 34
  - common problems & solutions 35
  - diagnostic LEDs 34
  - serial communication 36
  - test panels, Motion Architect 34
  - test program 34
- TTL-compatible switching voltage levels 3
- tuning (see matching)

## U-Z

- unipolar current 45
- velocity accuracy 3
- velocity range 3
- velocity repeatability 3
- VM50 adaptor 14
- waveform 23
- Z channel output 12
- ZETA motor (see motor)



## Setup

### ZETA, OS & RS MOTOR CONNECTIONS (see also pages 9 & 10)

#### Series Connection (factory default)

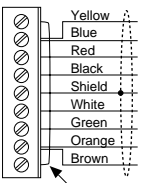

#### Parallel Connection

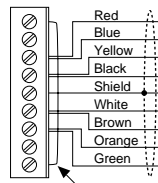

#### C10 & NPS Connections

Refer to page 10 for instructions on wiring an RS motor that is ordered with the -C10 option or the -NPS option.

Do not lengthen or remove this jumper.

### MOTOR MATCHING & CURRENT; ADDRESS (see also page 4)

Access through the top of the ZETA6104 chassis (loosen screws, move cover plate).

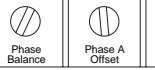

Motor matching – see page 22.

#### Motor Current

Motor	Amps	1	2	3	4	5
Zeta57-51(S)	1.26	off	on	off	off	on
Zeta57-83(S), OS2HB(S)	1.51	off	on	off	on	on
Zeta57-102(S)	1.76	off	on	on	on	on
OS21B(S)	1.88	off	on	on	on	off
OS22B(S)	2.14	on	off	off	off	off
Zeta83-62(S), RS31B(S)	2.26	on	off	off	off	on
Zeta57-51(P)	2.38	on	off	off	on	off
Zeta83-93(S), RS32B(S)	2.88	on	off	on	on	off
OS2HB(P)	3.01	on	on	off	on	on
Zeta57-83(P)	3.13	on	on	off	off	off
Zeta57-102(P)	3.50	on	on	off	on	on
Zeta83-135(S), RS33B(S)	3.75	on	on	on	off	on
OS21B(P)	4.00	on	on	on	on	on
Zeta83-xxx(P)						
OS22B(P), RS3xB(P)						

(S) = Series (P) = Parallel  
Non-Compumotor motor current settings – see page 4.

#### AutoBaud (see page 4)

enabled	on	off
disabled	off	on

#### Address

default → 0	off	off	off	off	off	off
1	off	off	off	off	on	on
2	off	off	off	on	off	off
3	off	off	off	on	on	off
4	off	off	on	off	off	off
5	off	off	on	off	off	off

TIP: The ADDR command allows you to automatically establish addresses for multiple units in a daisy-chain or multi-drop (ADDR address overrides the DIP switch setting).

(Binary Weighted)

31	on	on	on	on	on	on
----	----	----	----	----	----	----

### RS-485 CONFIGURATION (see also pages 5 & 8)

1. Change internal jumpers & DIP Switches:

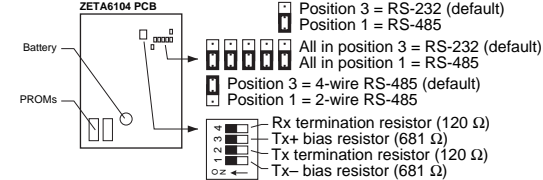

DIP switch: ON selects the resistor. Alternative: Set the switches to OFF and connect your own external resistors (see page 8 for calculations).

2. Execute the PORT2 and DRPCHK0 commands to change the COM 2 port.

### SOFTWARE-BASED SETTINGS (see also page 30)

Setting	Factory Default	Command
COM 1 Port Function	RS-232	PORT & DRPCHK
COM 2 Port Function	RP240	PORT & DRPCHK
Electronic Viscosity **	Disabled	DELVIS
Active Damping **	Disabled	DACTDP
Anti-Resonance	Enabled	DAREN
Auto Current Standby	Disabled	DAUTOS
Waveform	-4% 3rd harmonic	DWAVEF
Motor Inductance *	≥ 20 mH	DMTIND
Motor Static Torque *	36-100 Oz-in (0.26-0.72 N-m)	DMTSTT

\* Inductance and static torque are configured for ZETA motors ONLY if you ordered your ZETA6104 and ZETA motor together as a "system." A configuration procedure (part of matching) is provided on page 27.

\*\* These features work best if you "match the ZETA6104 to the motor" (see matching procedure on page 22).  
Active Damping configuration procedure – see page 26.  
Electronic Viscosity configuration procedure – see page 29.

## Connections

See also pages 7-19

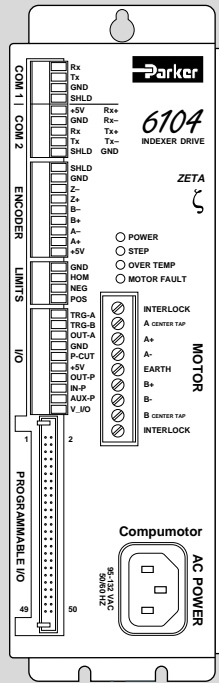

### I/O SPECIFICATIONS & INTERNAL SCHEMATICS

**AC Input** ..... 95-132VAC, 50/60Hz, single phase (peak power requirement – see page 18).

**Serial Com** .... RS-232C 3-wire; RS-485 4-wire (change jumpers JU1-JU6 to position 1, set JU7 to position 3 if you need 2-wire, select termination resistors).  
Up to 99 units in a daisy chain or multi-drop.  
9600 baud (or use AutoBaud feature – see page 4);  
8 data bits; 1 stop bit; no parity;

**Motors** ..... Compumotor motors (ZETA, OS and RS motors):  
Torque, inertia, bearings, weight – see page 3;  
Speed/torque curves – see page 10.  
Non-Compumotor motors – see page 43.

#### Limits, P-CUT, & Trigger Inputs

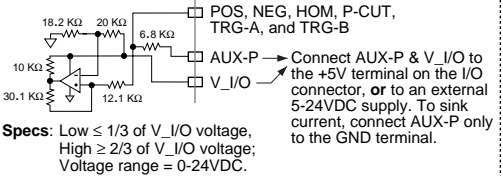

#### Encoder Inputs

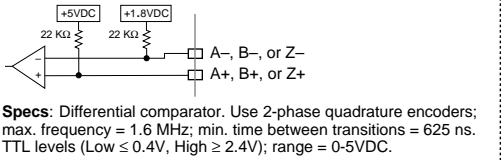

#### Programmable Inputs

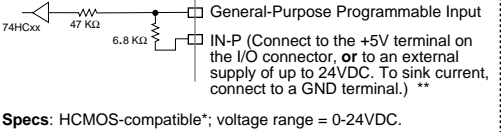

#### Programmable Outputs

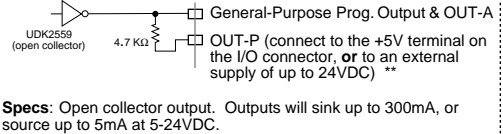

#### Terminals found on multiple connectors

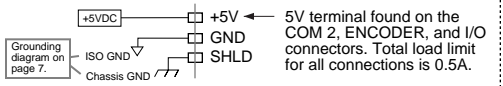

\* HCMOS-compatible levels: Low ≤ 1.00V, High ≥ 3.25V.

\*\* Disconnect from +5V terminal BEFORE connecting an external 5-24VDC supply.

## Troubleshooting

See also pages 33-37

- LEDs:**
  - POWER ..... 120VAC power is applied
  - STEP ..... Flashes green with each step pulse.
  - OVER TEMP ..... Max. drive temp limit (131°F, 55°C) exceeded.
  - MOTOR FAULT ..... Short circuit in motor windings, motor cable is disconnected or shorted, or INTERLOCK jumper is disconnected or extended.
- Status information (see command descriptions in 6000 Series Software Reference):**
  - General status information ..... TASF, TSSF, TSTAT
  - Limits (end-of-travel, home) ..... TASF, TLIM
  - P-CUT input ..... TINO (bit #6)
  - Programmable inputs and TRG-A/B ..... TIN, INFNC
  - Programmable outputs and OUT-A ..... TOUT, OUTFNC
  - Motor fault ..... TASXF (bit #1)
  - Low voltage fault ..... TASXF (bit #2)
  - Over temperature fault ..... TASXF (bit #3)
- P-CUT input must be grounded to GND terminal to allow motion.
- NEG & POS inputs must be grounded to GND terminal to allow motion (or disable with L#0 command).
- V\_I/O must be connected to 5-24VDC for the P-CUT, HOM, NEG, POS, & TRG-A/B inputs to work.
- To help prevent electrical noise, shield all connections at one end only.
- Error messages while programming or executing programs – see 6000 Series Programmer's Guide.
- Technical support – see phone numbers on inside of front cover, and the HELP command response.