

Up to PL c of EN ISO 13849-1 PNOZ s1



Safety relay for monitoring E-STOP pushbuttons and safety gates.

Approvals

PNOZ s1	
	◆
	◆
	◆

Unit features

- ▶ Relay outputs:
 - 2 safety contacts (N/O), instantaneous
- ▶ 1 semiconductor output
- ▶ Connection options for:
 - E-STOP pushbutton
 - Safety gate limit switch
 - Reset button
- ▶ A connector can be used to connect 1 PNOZsigma contact expander module
- ▶ LED indicator for:
 - Supply voltage
 - Input status, channel 1
 - Input status, channel 2
 - Switch status, safety contacts
 - Reset circuit
 - Error
- ▶ Plug-in connection terminals (either spring-loaded terminal or screw terminal)

- ▶ E-STOP pushbuttons
- ▶ Safety gates

Safety features

The relay meets the following safety requirements:

- ▶ The circuit is redundant with built-in self-monitoring.
- ▶ The safety function remains effective in the case of a component failure.
- ▶ The correct opening and closing of the safety function relays is tested automatically in each on-off cycle.
- ▶ The unit has an electronic fuse.

Unit description

The safety relay meets the requirements of EN 60947-5-1, EN 60204-1 and VDE 0113-1 and may be used in applications with

Block diagram

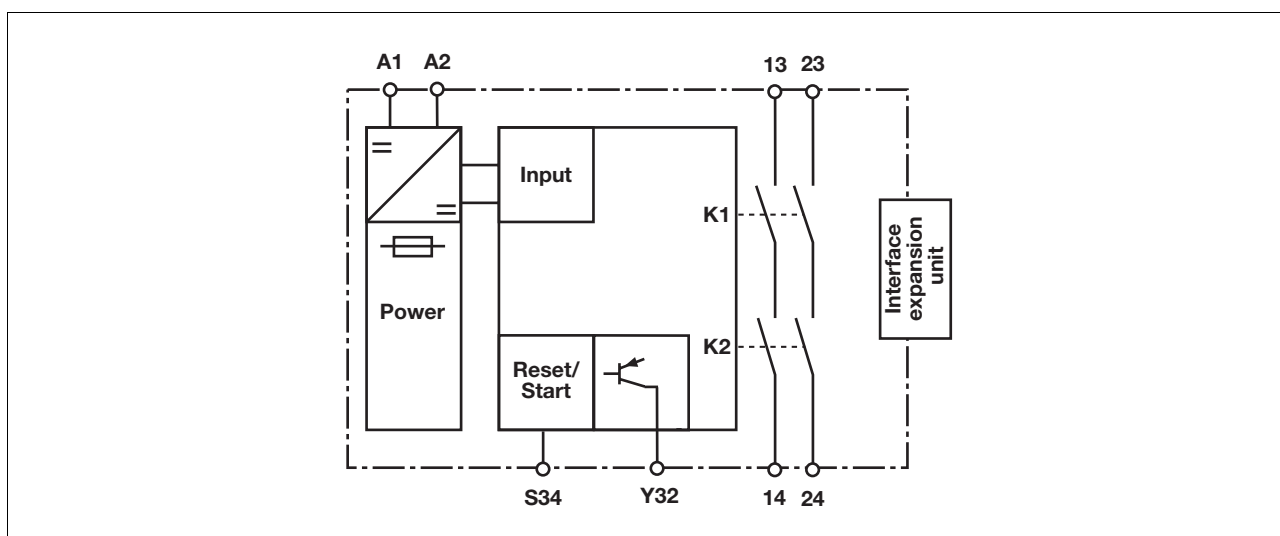

Up to PL c of EN ISO 13849-1 PNOZ s1

Function description

- ▶ Single-channel operation: no redundancy in the input circuit, earth faults in the reset and input circuit are detected.
- ▶ Automatic start: Unit is active once the input circuit has been closed.
- ▶ Manual reset: Unit is active once the input circuit is closed and then the reset circuit is closed.
- ▶ Increase in the number of available instantaneous safety contacts by connecting contact expander modules or external contactors/relays; A connector can be used to connect 1 PNOZsigma contact expander module.

Timing diagram

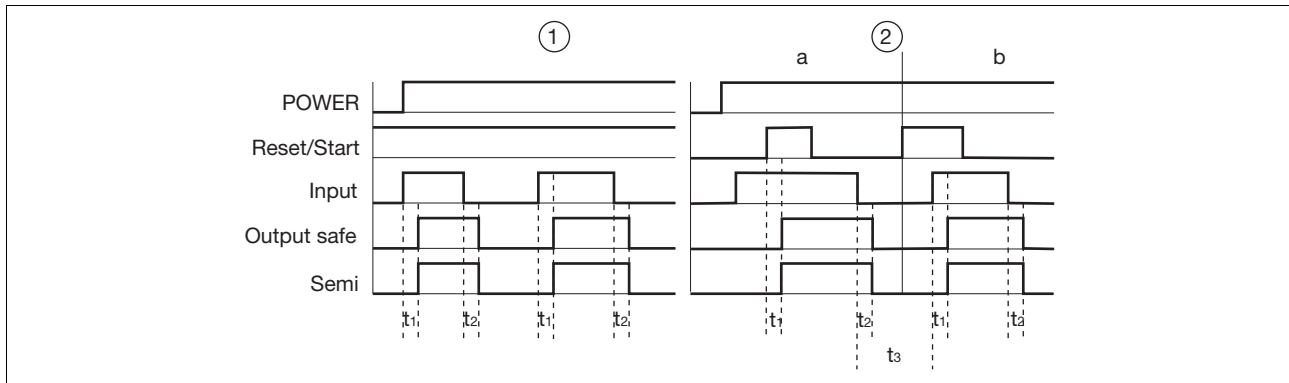

Key

- ▶ Power: Supply voltage
- ▶ Reset/Start: Reset circuit S34
- ▶ Input: Input circuits A1-A2
- ▶ Output safe: Safety contacts 13-14, 23-24
- ▶ Semi: Semiconductor output Y32
- ▶ ①: Automatic reset
- ▶ ②: Manual reset
- ▶ a: Input circuit closes before reset circuit
- ▶ b: Reset circuit closes before input circuit
- ▶ t₁: Switch-on delay
- ▶ t₂: Delay-on de-energisation
- ▶ t₃: Recovery time

Wiring

Please note:

- ▶ Information given in the “Technical details” must be followed.
- ▶ Outputs 13-14, 23-24 are safety contacts.
- ▶ To prevent contact welding, a fuse should be connected before the output contacts (see technical details).
- ▶ Calculation of the max. cable runs I_{max} in the input circuit:

$$I_{max} = \frac{R_{I_{max}}}{R_l / km}$$

$R_{I_{max}}$ = max. overall cable resistance (see technical details)

R_l / km = cable resistance/km

- ▶ Use copper wire that can withstand 60/75 °C.
- ▶ Sufficient fuse protection must be provided on all output contacts with capacitive and inductive loads.

Up to PL c of EN ISO 13849-1 PNOZ s1

Preparing for operation

► Supply voltage

Supply voltage	AC	DC

► Input circuit

Input circuit	Single-channel	Dual-channel
E-STOP without detection of shorts across contacts		
Safety gate without detection of shorts across contacts		

► Reset circuit

Reset circuit	Reset circuit	Feedback circuit
Automatic reset		
Manual reset		

Up to PL c of EN ISO 13849-1 PNOZ s1

▶ Semiconductor output

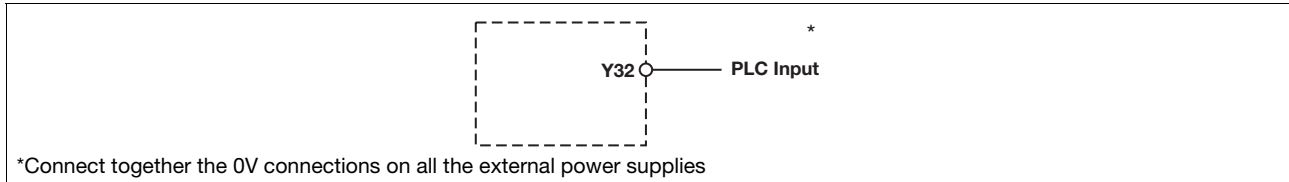

▶ Key

S1	E-STOP pushbutton
S3	Reset button
	Switch operated
	Gate open
	Gate closed

INFORMATION

If a base unit and a contact expansion module from the PNOZsigma range are linked via the connector, no additional wiring is necessary.

Up to PL c of EN ISO 13849-1 PNOZ s1

Terminal configuration

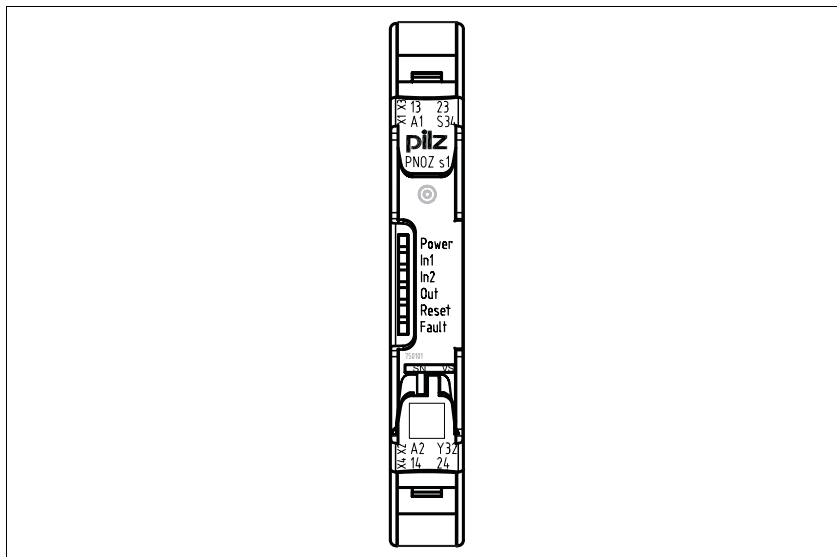

Installation

Install base unit without contact expander module:

- ▶ Ensure that the plug terminator is inserted at the side of the unit.

Connect base unit and PNOZsigma contact expander module:

- ▶ Remove the plug terminator at the side of the base unit and at the contact expander module.
- ▶ Connect the base unit and the contact expander module to the supplied connector before mounting the units to the DIN rail.

Installation in control cabinet

- ▶ The safety relay should be installed in a control cabinet with a protection type of at least IP54.
- ▶ Use the notch on the rear of the unit to attach it to a DIN rail (35 mm).
- ▶ When installed vertically: Secure the unit by using a fixing element (e.g. retaining bracket or end angle).
- ▶ Push the unit upwards or downwards before lifting it from the DIN rail.

Dimensions

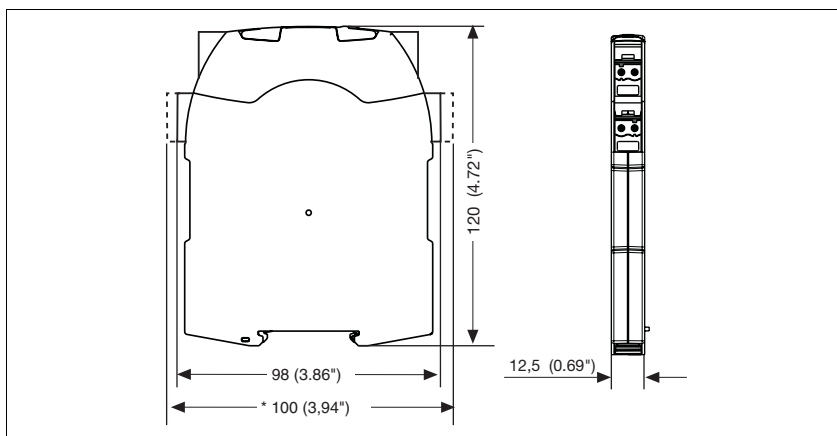

Up to PL c of EN ISO 13849-1 PNOZ s1

NOTICE

This data sheet is only intended for use during configuration. For installation and operation, please refer to the operating instructions supplied with the unit.

Technical details	
Electrical data	
Supply voltage	
Supply voltage U_B DC	24 V
Voltage tolerance	-15 %/+10 %
Power consumption at U_B DC	2.0 W
Residual ripple DC	20 %
Voltage and current at	
Input circuit DC: 24.0 V	60.0 mA
Reset circuit DC: 24.0 V	20.0 mA
Feedback loop DC: 24.0 V	20.0 mA
Number of output contacts	
Safety contacts (S) instantaneous:	2
Utilisation category in accordance with EN 60947-4-1	
Safety contacts: AC1 at 240 V	I_{min} : 0.02 A , I_{max} : 3.0 A P_{max} : 720 VA
Safety contacts: DC1 at 24 V	I_{min} : 0.02 A , I_{max} : 3.0 A P_{max} : 72 W
Utilisation category in accordance with EN 60947-5-1	
Safety contacts: AC15 at 230 V	I_{max} : 1.5 A
Safety contacts: DC13 at 24 V (6 cycles/min)	I_{max} : 1.5 A
Contact material	AgSnO2
External contact fuse protection ($I_K = 1$ kA) to EN 60947-5-1	
Blow-out fuse, quick	
Safety contacts:	4 A
Blow-out fuse, slow	
Safety contacts:	2 A
Circuit breaker 24 VAC/DC, characteristic B/C	
Safety contacts:	2 A
Semiconductor outputs (short circuit proof)	24.0 V DC, 20 mA
Max. overall cable resistance R_{lmax} input circuits, reset circuits single-channel at U_B DC	30 Ohm
Safety-related characteristic data	
PL in accordance with EN ISO 13849-1	PL c (Cat. 3)
Category in accordance with EN 954-1	Cat. 3
SIL CL in accordance with EN IEC 62061	SIL CL 2
PFH in accordance with EN IEC 62061	2.00E-07
SIL in accordance with IEC 61511	SIL 2
PFD in accordance with IEC 61511	5.95E-03
t_M in years	20
Times	
Switch-on delay	
with automatic reset typ.	100 ms
with automatic reset max.	150 ms
with automatic reset after power on typ.	100 ms
with automatic reset after power on max.	150 ms
with manual reset typ.	50 ms
with manual reset max.	60 ms

Up to PL c of EN ISO 13849-1 PNOZ s1

Times	
Delay-on de-energisation	
with E-STOP typ.	30 ms
with E-STOP max.	40 ms
with power failure typ.	30 ms
with power failure max.	40 ms
Recovery time at max. switching frequency 1/s	
after E-STOP	100 ms
after power failure	100 ms
Supply interruption before de-energisation	10 ms
Environmental data	
EMC	EN 60947-5-1, EN 61000-6-2, EN 61000-6-4
Vibration to EN 60068-2-6	
Frequency	10 - 55 Hz
Amplitude	0.35 mm
Climatic suitability	EN 60068-2-78
Airgap creepage in accordance with EN 60947-1	
Pollution degree	2
Overvoltage category	III
Rated insulation voltage	250 V
Rated impulse withstand voltage	4.00 kV
Ambient temperature	-10 - 55 °C
Storage temperature	-40 - 85 °C
Protection type	
Mounting (e.g. cabinet)	IP54
Housing	IP40
Terminals	IP20
Mechanical data	
Housing material	
Housing	PC
Front	PC
Cross section of external conductors with screw terminals	
1 core flexible	0.25 - 2.50 mm ² , 24 - 12 AWG No. 750101
2 core, same cross section, flexible:	
with crimp connectors, without insulating sleeve	0.25 - 1.00 mm ² , 24 - 16 AWG No. 750101
without crimp connectors or with TWIN crimp connectors	0.20 - 1.50 mm ² , 24 - 16 AWG No. 750101
Torque setting with screw terminals	0.50 Nm No. 750101
Cross section of external conductors with spring-loaded terminals: Flexible with/without crimp connectors	0.20 - 2.50 mm ² , 24 - 12 AWG No. 751101
Spring-loaded terminals: Terminal points per connection	2 No. 751101
Stripping length	9 mm No. 751101
Dimensions	
Height	100.0 mm No. 751101 98.0 mm No. 750101
Width	12.5 mm
Depth	120.0 mm
Weight	105 g

No. stands for order number.

All the units used within a safety function must be considered when calculating the safety characteristic data.

The standards current on **2006-04** apply.

Up to PL c of EN ISO 13849-1 PNOZ s1

Conventional thermal current

I_{th} (A) at U_B DC

1 contact **3.00 A**

2 contacts **3.00 A**

Order reference

Type	Features	Terminals	Order no.
PNOZ s1	24 VDC	With screw terminal	750 101
PNOZ s1 C	24 VDC	With spring-loaded terminal	751 101