

Expansion modules

PNOZ ms2p



Speed monitor for connection to a base unit from the PNOZmulti modular safety system

Approvals

	PNOZ ms2p
	◆
	◆
	◆

Unit features

- ▶ Monitoring of 2 independent axes
- ▶ Connection per axis
 - 1 incremental encoder or
 - 2 proximity switches or
 - 1 incremental encoder and 1 proximity switch
- ▶ Measured variables:
 - Standstill
 - Speed (8 values can be set)
 - Direction of rotation
- ▶ Axis types, input device types and reset mode can be selected in the PNOZmulti Configurator
- ▶ Status indicators for
 - Supply voltage
 - Incremental encoders
 - Proximity switches
 - Axis status, standstill and excess speed
 - Faults on the system
- ▶ Proximity switch connection technology: Plug-in connection terminals (either cage clamp terminal or screw terminal)
- ▶ Incremental encoder connection technology: RJ-45 female connector
- ▶ Galvanic isolation between the connections X1, X12 and X22
- ▶ Max. 4 speed monitors can be connected to the base unit

Unit description

It monitors standstill, speed and direction of rotation up to Category 3 of EN 954-1. The expansion module may only be connected to a base unit from the PNOZmulti modular safety system. The PNOZmulti modular safety system is used for the safety-related interruption of safety circuits and is designed for use on:

- ▶ Emergency stop equipment
- ▶ Safety circuits in accordance with VDE 0113 Part 1 and EN 60204-1

System requirements

- ▶ PNOZmulti Configurator: from Version 5.1.0
 - ▶ Base unit PNOZ m1p: from Version 5.2
 - ▶ Base unit PNOZ m2p: from Version 2.2
- Please contact Pilz if you have an older version.

Safety features

The relay conforms to the following safety criteria:

- ▶ The circuit is redundant with built-in self-monitoring.
- ▶ The safety function remains effective in the case of a component failure.

Block diagram

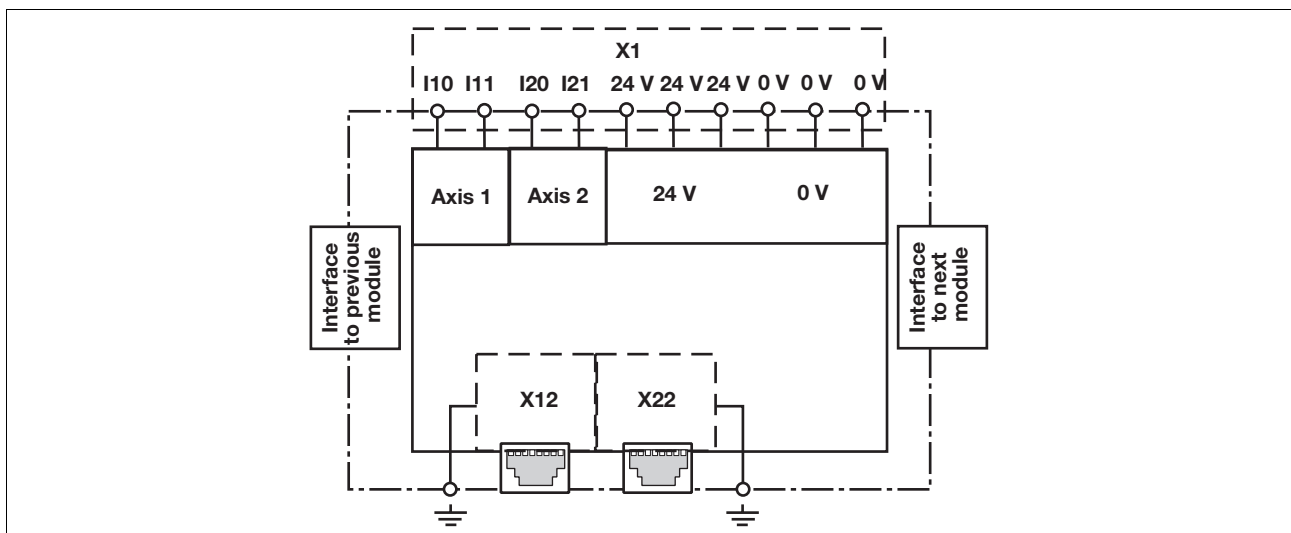

Expansion modules PNOZ ms2p

Function description

The speed monitor can independently monitor two axes for standstill, speed and direction of rotation. The speed

monitor signals the status of the monitored values to the base unit. Depending on the safety circuit loaded, the values can be transferred from the base unit, e.g. to a relay output on the

safety system. Incremental encoders and/or proximity detectors can be used to record the values.

Wiring

The wiring is defined in the circuit diagram in the Configurator.

Details of the input type, axis type and reset mode, plus the values for standstill, speed monitoring and direction of rotation are also defined in the Configurator.

Please note:

- ▶ Information given in the "Technical details" must be followed.
- ▶ Use copper wire that can withstand 75 °C.

Proximity switches

- ▶ Only "pnp" type proximity switches may be used (N/O contact, positive-switching)
- ▶ The proximity switches must be positioned in such a way that at least one is energised (carries a high signal).
- ▶ The proximity switches must be offset in such a way that the recorded signals overlap.

The outputs of both the proximity switches for axis 1 are connected to terminals I10 and I11; both the outputs of the proximity switches for axis 2 are connected to terminals I20 and I21. If only one axis is to be monitored, either terminals I10 and I11 or terminals I20 and I21 will remain free. The proximity switch must always be connected to a 0 V terminal on the speed monitor. The 0 V terminals are linked internally.

The proximity switches require a 24 VDC supply. To reduce the amount of wiring involved, this supply voltage can be connected to one of the "24 V" terminals on the PNOZ ms1p. As all 3 "24 V" terminals are linked internally, 24 V will be present at all 3 terminals. The proximity switches can therefore be connected directly to the 24 V terminals on the speed monitor, rather than the power supply.

Incremental encoders

- ▶ Only incremental encoders with a differential output of the following type are permitted
 - Sin/Cos
 - TTL (RS 422)
 - HTL (24 V)

The incremental encoders are connected via an adapter or are connected directly to the speed monitor (see data sheets: "Connection cable, adapter for PNOZ ms1p"). The adapter is connected between the incremental encoder and the drive. The output on the adapter is connected to the RJ-45 female connector on the speed monitor. The incremental encoder on connector X12 monitors axis 1; the incremental encoder on connector X22 monitors axis 2.

Incremental encoder and proximity switch on one axis

From Version 2.0 of the PNOZ ms1p/PNOZ ms2p speed monitor, an incremental encoder and a proximity switch may be configured on one axis to increase availability. That way the speed monitor can monitor 3 signals on one axis: Track A and track B of the incremental encoder plus the proximity switch:

Standstill monitoring

Standstill is detected when at least two of these signals fall below the standstill frequency.

Monitoring for broken shearpins

A broken shearpin is detected when

- ▶ Both tracks of the incremental encoder signal "Standstill"

and

- ▶ The proximity switch signals "Rotating shaft"

This status will only lead to a safe condition if the option for broken shearpin monitoring has been activated in the configuration.

Expansion modules

PNOZ ms2p

Preparing for operation

- ▶ Proximity switch

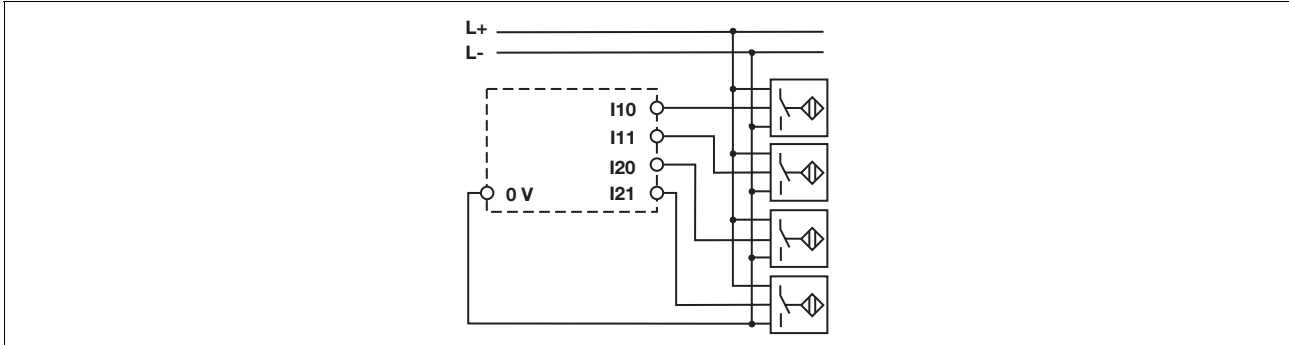

- ▶ Incremental encoder

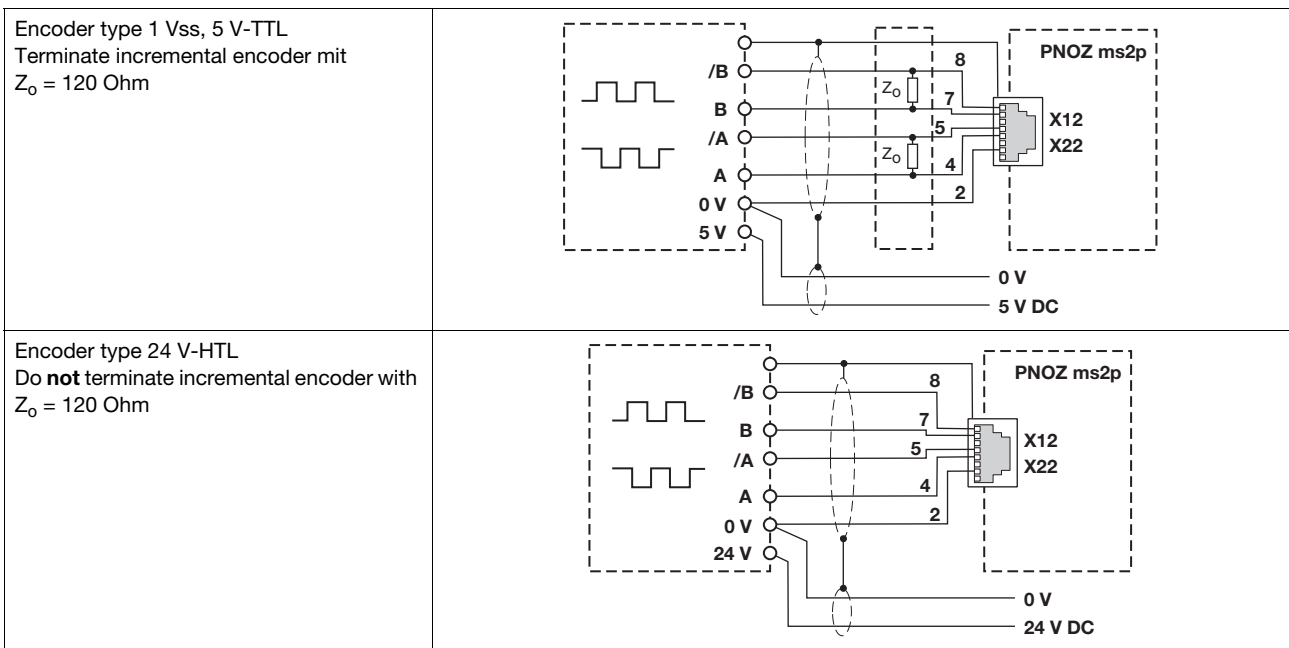

Expansion modules PNOZ ms2p

- Proximity switch and incremental encoder

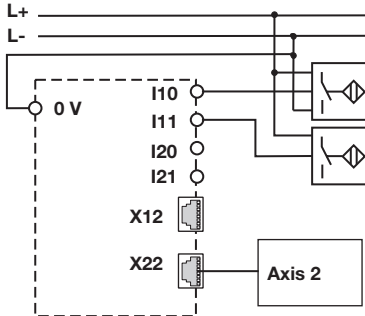
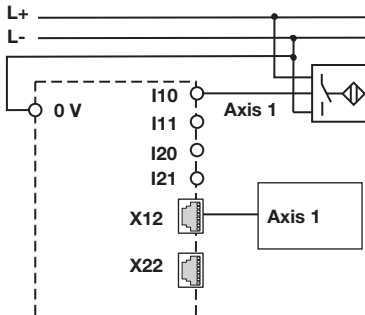
<p>Proximity switch and incremental encoder on various axes</p> <p>Axis 1: Proximity switch at I10, I11 or Incremental encoder at X12</p> <p>Axis 2: Proximity switch at I20, I21 or Incremental encoder at X22</p>	
<p>Proximity switch and incremental encoder on one axis</p> <p>Axis 1: Proximity switch at I10 (I11 remains free) and Incremental encoder at X12</p> <p>Axis 2: Proximity switch at I20 (I21 remains free) and Incremental encoder at X22</p>	

Expansion modules

PNOZ ms2p

Terminal configuration

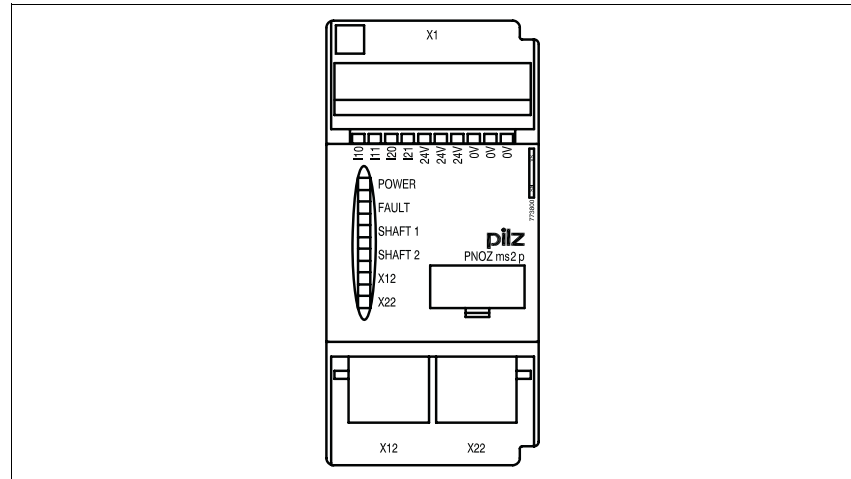

Installation

- ▶ The safety system should be installed in a control cabinet with a protection type of at least IP54. Fit the safety system to a horizontal DIN rail. The venting slots must face upward and downward. Other mounting positions could damage the safety system.
- ▶ Use the notches on the back of the unit to attach it to a DIN rail. Connect the safety system to the DIN rail in an upright position, so that the earthing springs on the safety system are pressed on to the DIN rail.
- ▶ To comply with EMC requirements, the DIN rail must have a low impedance connection to the control cabinet housing.

Dimensions

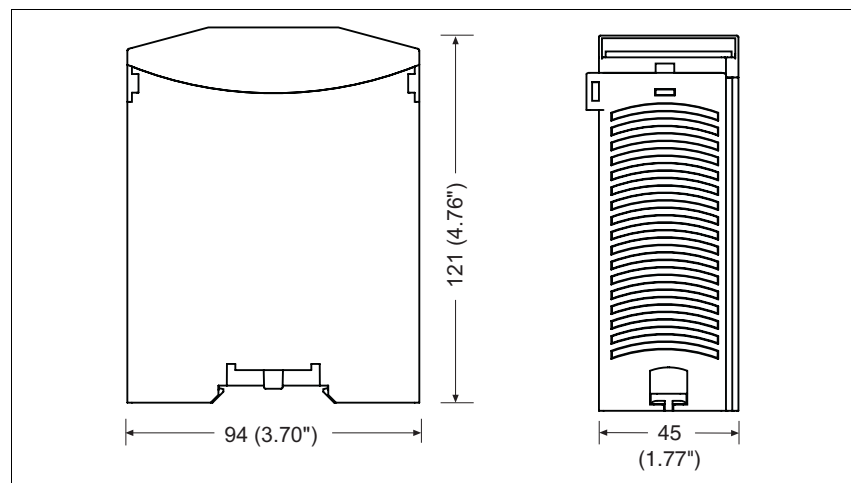

Expansion modules PNOZ ms2p

Notice

This data sheet is only intended for use during configuration. For installation and operation, please refer to the op-

erating instructions supplied with the unit.

Technical details	
Electrical data	
Supply voltage (U_B) via base unit	24 VDC
Voltage tolerance	-15% ... 10%
Power consumption at U_B via base unit	Typ. 1 W
Residual ripple U_B	+/- 5 %
Times	
Supply interruption before de-energisation	Min. 20 ms
Configurable switch-off delay	0 ... 2500 ms
Reaction time $f \geq 100$ Hz: Configurable switch-off delay + Switch-off delay PNOZ m1p + $f < 100$ Hz: Configurable switch-off delay + Switch-off delay PNOZ m1p +	10 ms 10 ms + 1/f
Proximity switch input	
Number of inputs	4 (2 axes)
Signal level at the inputs "1" Signal (high)	11 V ... 30 V
"0" Signal (low)	-3 ... 5 V
Input resistance	3 kOhm
Input's frequency range	0 ... 3 kHz
Configurable monitoring frequency Without hysteresis	1 Hz ... 3 kHz
With hysteresis	2 Hz ... 3 kHz
Connection type	Cage clamp terminals
Cross section of external conductors Rigid single-core, flexible multi-core or multi-core With crimp connector	0.5 ... 2.5 mm²
Flexible multi-core with plastic sleeve	0.5 ... 1.5 mm²
Incremental encoder input	
Number of inputs	2 (2 axes)
Supply voltage for incremental encoders	Independent
Signal level at the inputs	0.5 V_{SS} ... 30 V_{SS}
Phase position for the differential signals A, /A and B	90° ±30°
Overload protection	-30 V ... +30 V
Input resistance	20 kOhm
Input's frequency range	0 ... 500 kHz
Configurable monitoring frequency Without hysteresis	1 Hz ... 500 kHz
With hysteresis	2 Hz ... 500 kHz
Connection type	RJ-45 female connector
Environmental data	
Airgap creepage	DIN VDE 0110-1, 04/97
Vibration in accordance with EN 60068-2-6, 04/95 Frequency:	10 ... 55 Hz
Amplitude:	0.35 mm
Climatic suitability	DIN IEC 60068-2-3, 12/86 DIN CEI 60068-2-3, 12/86
EMC	EN 60947-5-1, 01/00
Ambient temperature	0 ... +55 °C
Storage temperature	-25 ... +70 °C

Expansion modules

PNOZ ms2p

Mechanical data

Protection type	
Mounting (e.g. cabinet)	IP54
Housing	IP20
Terminals	IP20
DIN rail	
Top hat rail	35 x 7.5 EN 50022
Recess width	27 mm
Torque setting for connection terminals (screws)	0.4 ... 0.5 Nm
Housing material	
Housing	PPO UL 94 V0
Front	ABS UL 94 V0
Dimensions (H x W x D)	94 x 45 x 121 mm
Weight with connector	220 g

Order reference

Type	Features	Order no.
PNOZ ms2p	Expansion module Speed monitor	773 810