

STO classified PL e using PMCprotego D and PNOZ mm0p



Product

Type: PMC
Name: PMCprotego D, PNOZ mm0p
Manufacturer: Pilz GmbH & Co. KG, Safe Automation

Document

Release Number: 02
Release Date: 15 July 2011

Document Revision History

Release	Date	Changes	Chapter
01	2011-03-23	Creation	all
02	2011-07-15	Revision documentation	1

Exclusion of liability

We have taken great care in compiling our application note. It contains information about our company and our products. All statements are made in accordance with the current status of technology and to the best of our knowledge and belief.

However, we cannot accept liability for the accuracy and entirety of the information provided, except in the case of gross negligence. In particular it should be noted that statements do not have the legal quality of assurances or assured properties.

We are grateful for any feedback on the contents.

July 2011

All rights to this publication are reserved by Pilz GmbH & Co. KG. We reserve the right to amend specifications without prior notice. Copies may be made for the user's internal purposes. The names of products, goods and technologies used in this manual are trademarks of the respective companies.

Support

Technical help round the clock!

Technical support is available from Pilz round the clock.

This service is provided free of charge beyond standard business hours.

Americas

- ▶ Brazil
+55 11 8245-8267
- ▶ Mexico
+52 55 5572 1300
- ▶ USA (toll free)
+1 877-PILZUSA (745-9872)

Asia

- ▶ China
+86 21 62494658-216
- ▶ Japan
+81 45 471-2281
- ▶ Korea
+82 2 2263 9540

Australia

- ▶ Australia
+61 3 95446300

Europe

- ▶ Austria
+43 1 7986263-0
- ▶ Belgium, Luxembourg
+32 9 3217575
- ▶ England
+44 1536 462203
- ▶ France
+33 3 88104000
- ▶ Germany
+49 711 3409-444
- ▶ Ireland
+353 21 4804983
- ▶ Italy
+39 031 789511
- ▶ Scandinavia
+45 74436332
- ▶ Spain
+34 938497433
- ▶ Switzerland
+41 62 88979-30
- ▶ The Netherlands
+31 347 320477
- ▶ Turkey
+90 216 5775552

You can reach our international hotline on:

+49 711 3409-444 or <mailto:support@pilz.com>

Pilz GmbH & Co. KG
Safe Automation
Felix-Wankel-Straße 2
73760 Ostfildern, Germany

Telephone: +49 711 3409-0
Telefax: +49 711 3409-133
E-Mail: pilz.gmbh@pilz.de
Internet: www.pilz.com

Contents

1. Useful documentation	5
1.1. Documentation from Pilz GmbH & Co. KG	5
1.2. Documentation from other sources of information	5
2. Hardware configuration.....	6
2.1. Pilz products.....	6
2.2. Hardware-configuration.....	6
3. Application Task	7
3.1. Description	7
3.1.1. Safe pulse disabler of servo amplifier.....	8
3.1.2. Testing the safe pulse disabler.....	9
3.1.3. Circuitry and parameterisation.....	9
3.1.4. Signal table	10
3.1.5. Timing diagram	10
3.1.6. STO feedback loop test flow chart.....	10
3.1.7. Inputs and outputs on PNOZmulti Mini.....	12
3.1.8. Safety assessments.....	12
3.2. Functional safety	12
3.3. Circuit diagram of the application.....	13
3.3.1. Circuit diagram 1/4.....	13
3.3.2. Circuit diagram 2/4.....	14
3.3.3. Circuit diagram 3/4.....	15
3.3.4. Circuit diagram 4/4.....	16

Abbreviations

PMC	Pilz Motion Control	
PNOZ	Pilz E-STOP Positive-Guided	(DE: Pilz NOT-AUS-Zwangsgeföhrt)
PRG	Program	
STO	Safe Torque Off	
RTO	Ready To Operate	(DE: BTB - Betriebsbereit)
FW	Firmware	
PDrive	Setup software for setting parameters and configuring servo amplifiers of the PM Ctendo DD4/5, PMCprimo Drive 2/3 and PMCprotego D series.	

1. Useful documentation

Reading the documentation listed below is necessary for understanding this application note. The availability of the indicated tools and safe handling are also presupposed with the user.

1.1. Documentation from Pilz GmbH & Co. KG

No.	Description	Item No.
1	Pilz international homepage, download section	www.pilz.com
2	Operating Manual PNOZ mm0p	1001274-EN-xx
3	Operating Manual PMCprotego D.01...D.24	21 934-EN-xx
4	Operating Manual PMctendo AC	21 706-EN-xx
5	User Manual Motion Control Tools	21 468-EN-xx

1.2. Documentation from other sources of information

No.	Description	Item No.
1		
2		

2. Hardware configuration

2.1. Pilz products

No.	Description	Order number	Version	Number
1	PNOZ mm0p	772 000	-	1
2	PMC protego D.03/000/0	8176 101	(from FW 5.24)	1
3	Cable Power DD4plug>ACplug:L05m	8165 882	-	1
4	Cable Hiperface DD4plug>ACpluf:L05m	8165 879	-	1
5	PNOZmulti Configurator	-	V7.1.0 build 4	1
6	PMCTools	-	V3.3	1

2.2. Hardware-configuration



Configured Hardware		
	Module Name	Version
0	Base Unit Mini PNOZ mm0p	v1.0

3. Application Task

3.1. Description

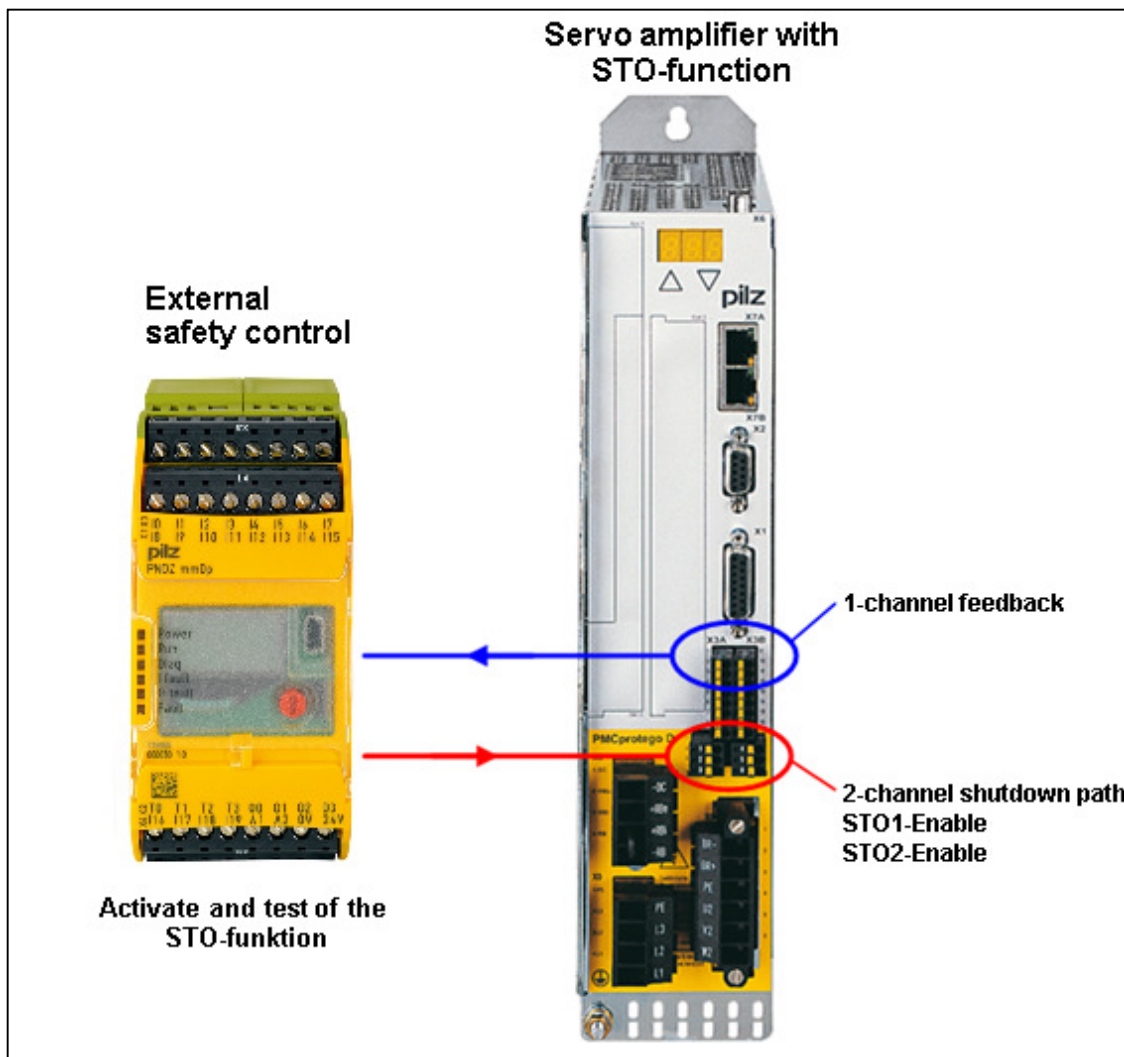

With the PMCprotego D, the highest safety level (PL_e / SIL3) can also be achieved for the STO function without an additional safety card (PMCprotego S1) if the shutdown paths of the PMCprotego D are tested by an external device (e.g. safety control) – referred to as “STO Feedback Loop Test” in the following.

This Application Note shows in principle the procedure for such a test.

The feedback signal of the PMCprotego D necessary for this test can be activated if the firmware is version 5.24 or later and can be configured for any output on the PMCprotego D. At the moment, this must be done with the PTerm terminal program and the OxMODE70 instruction.

In the future, this feedback loop function will be configurable in PDrive.

3.1.1. Safe pulse disabler of servo amplifier

The safe pulse disabler of the servo amplifier consists of two shutdown paths that can, independently of each other, switch off the power supply to the motor using the inputs 'STO1-ENABLE' and 'STO2-ENABLE'. As a cyclical test of the pulse disabler during operation is inadvisable for availability reasons, a function test of the shutdown paths must be performed at least before the release of the drive, once the PMCprotego D has run up and, in addition, every 8 hours (see section 3.1.8 PMC safety assessment).

The control of the pulse disabler can be made via a block in the PNOZmulti Mini (e.g. emergency stop or light curtain); for that the enable signal of the block is to be linked to the result of the STO feedback loop test for this purpose.

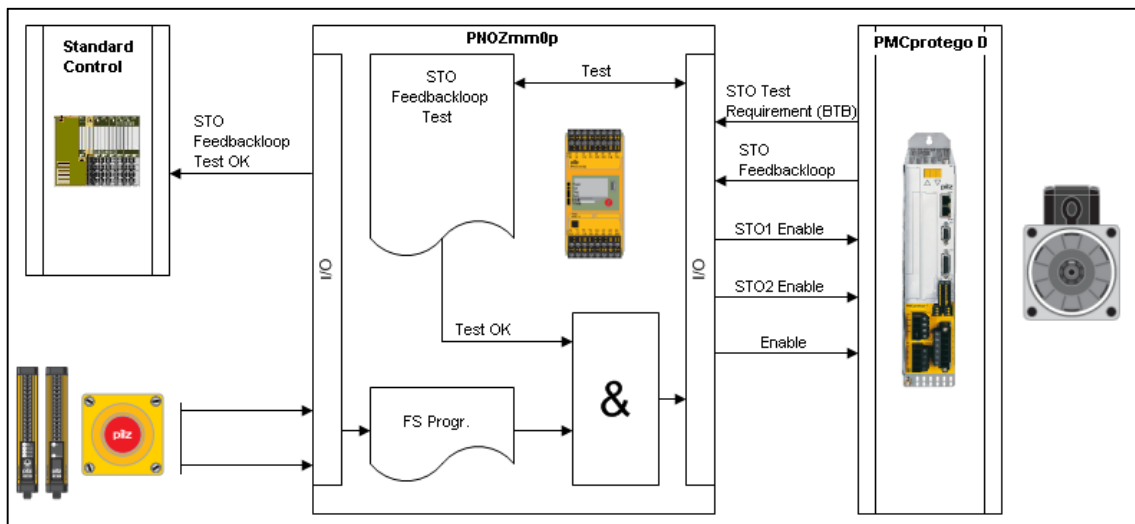

3.1.2. Testing the safe pulse disabler

When testing the safe pulse disabler, the two shutdown paths STO1-Enable and STO2-Enable are switched off in sequence, independently of each other, and the relevant switching state of the pulse disabler checked using the read-back signal 'STO feedback loop'.

The read-back signal 'STO feedback' can be connected to a digital output of the servo amplifier using the instruction OxMODE 70 if the amplifier has firmware version 5.24 or later. This enables the function of the safe pulse disabler to be tested from an external safety control and the drive safely operated if the highest safety level is to be achieved.

Testing the safe pulse disabler is done:

- ▶ at run up of the system (PNOZmulti Mini and PMCprotego D).
- ▶ on restart after a protection device has been triggered.
- ▶ after a periodic triggering (8-hour interval) by the operator (see 3.1.8 Safety assessment – PMC safety assessment).

The test sequence is started by the BTB/RTO contacts of the PMCprotego D; this ensures that the test is always carried out when the PMCprotego D changes over into the operational readiness state (BTB or RTO). This is the case after a restart or fault reset of the PMCprotego D.

If the test is successfully completed, an output on the PNOZmulti Mini is also set (“STO feedback loop test OK”) which the user can employ for enabling the start of his sequence control system.

If the test is requested during operation of the inverter, it should first be ensured that the enable input and then the STO inputs of the PMCprotego D are switched off. If not, a fault F27 is triggered that has to be reset before the PMCprotego D can be restarted.

3.1.3. Circuitry and parameterisation

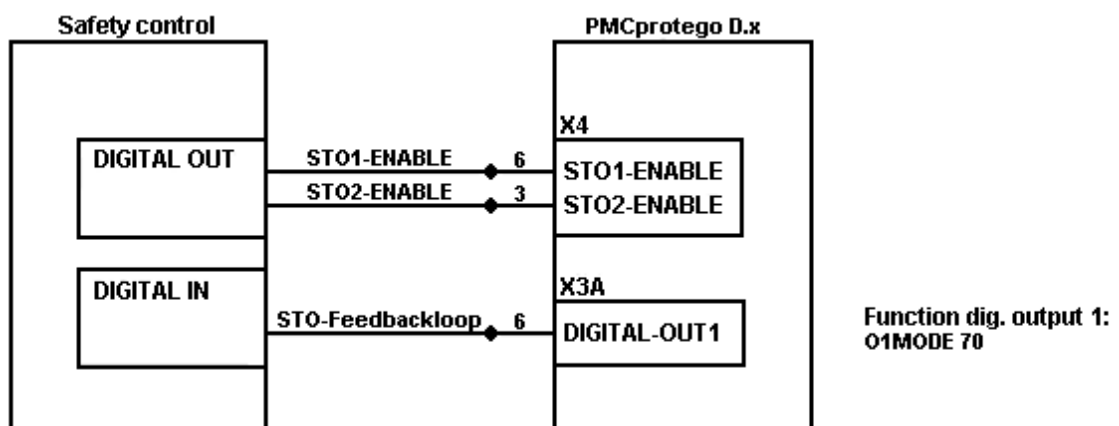

3.1.4. Signal table

STO1-Enable	STO2-Enable	STO-Feedbackloop
0	0	1
0	1	1
1	0	1
1	1	0

3.1.5. Timing diagram

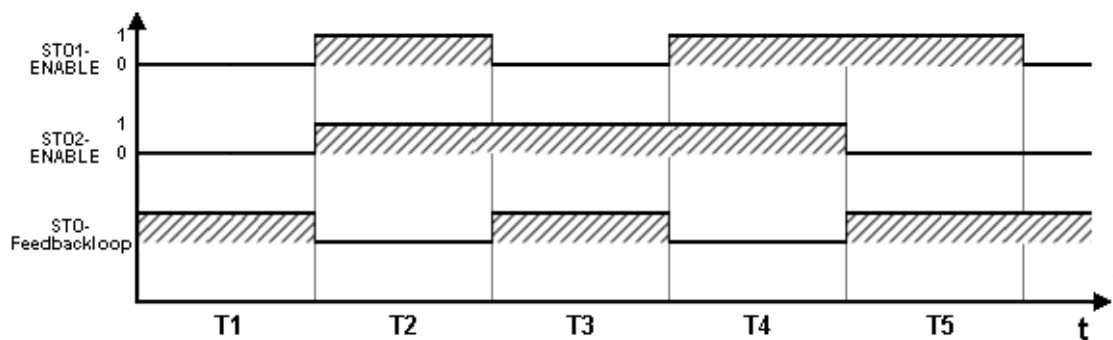

3.1.6. STO feedback loop test flow chart

The sequence of the STO feedback loop test shown in the following sequence schedule can be implemented, e.g. in the PNOZmulti, by means of a step sequence. This test sequence has to be integrated by the user into his PNOZmulti Mini project.

The test result in this must be connected by the user, e.g. with the enable signal of the emergency stop used or the safety gate block, and so control the inputs STO1 Enable or STO2 Enable of the PMCprotego D.

The user has to ensure that an enabling of the PMCprotego D can only take place when the test sequence has been successfully completed.

Generally, the user shall ensure that the STO feedback loop test/test sequence is carried out in the PNOZmulti Mini at the times given in sub-section 3.1.2.

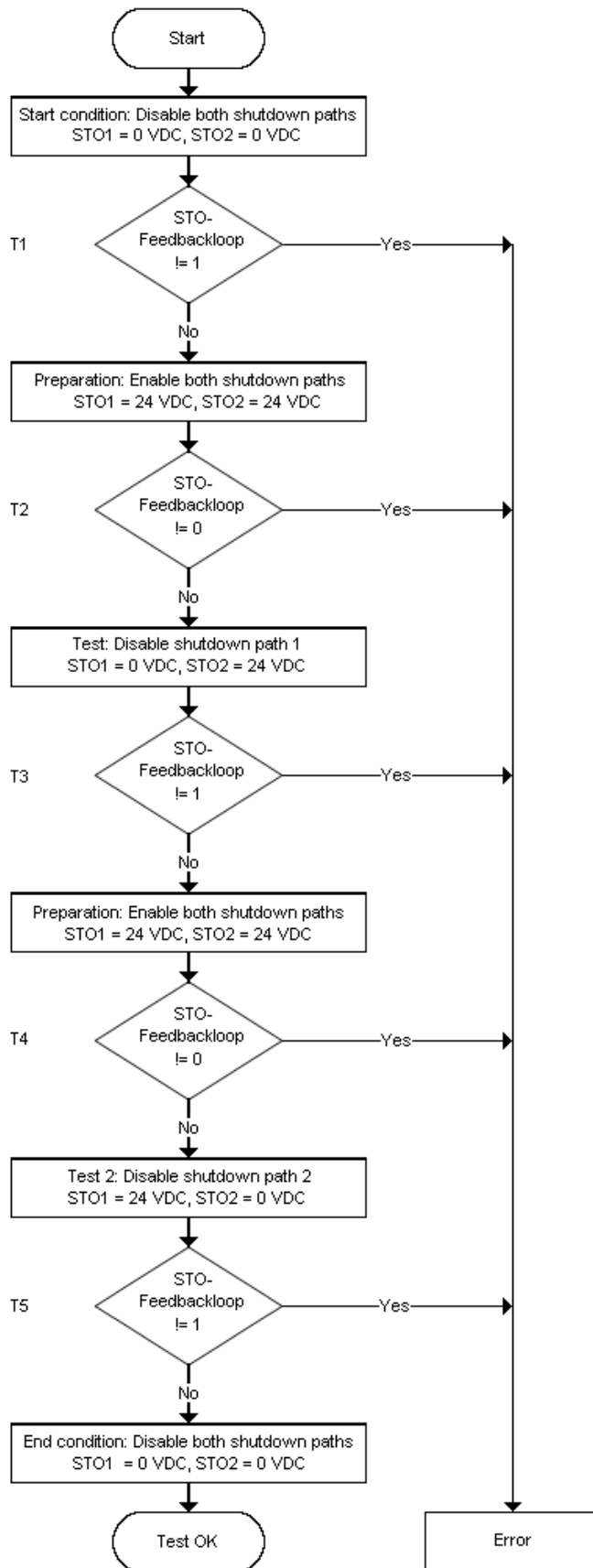

3.1.7. Inputs and outputs on PNOZmulti Mini

PNOZmulti outputs:

STO1 Enable
STO2 Enable
STO feedback loop test OK
Enable

PNOZmulti inputs:

STO Test requirement (BTB/RTO)
STO Feedback loop signal from PMCprotego D
Request STO1
Request STO2

3.1.8. Safety assessments

Input circuit safety assessment

- ▶ If the feedback loop test sequence result is negative, STO1 Enable and STO2 Enable in PNOZmulti Mini are set to low level and so activate the safe pulse disable of the inverter!
- ▶ The enable signals of a safety block used are only passed on to the PMCprotego D (STO1 Enable or STO2 Enable) when the feedback loop test sequence result is positive.

PMC safety assessment

The operating company must ensure that the function of the safe pulse disabler is tested, at least every 8 hours, by triggering safety functions.

Overall application safety assessment

- ▶ The PNOZmulti Mini and the PMCprotego D must be installed in the same mounting area in order to exclude a short circuit between 24 VDC and a safety input of the modules.
- ▶ A fault in the PNOZmulti Mini or PMCprotego D does not lead to a loss of the safety function.

3.2. Functional safety

The fault-free execution of the STO feedback loop test (functional test of the safe pulse disabler) is the basic precondition that the safety function STO of the servo amplifier PMCprotego D can achieve PL e and SIL3.

User-related safety functions (e.g. safety-related stop function, initiated by a safeguard) that can be executed with this, require its own classification (calculation) of the safety level for the overall safety chain.

-A1

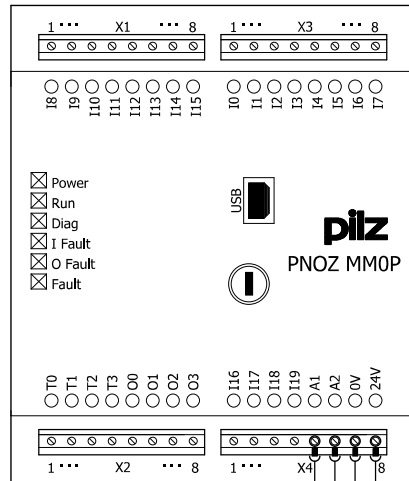

The classification in the specified safety level PL e and SIL3 refers to the safety function STO of the PMCprotego D and can be reached only under the following condition:
 - The function test, described in this application note, of the PMCprotego D was performed correct and passed.

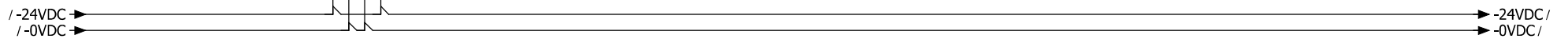

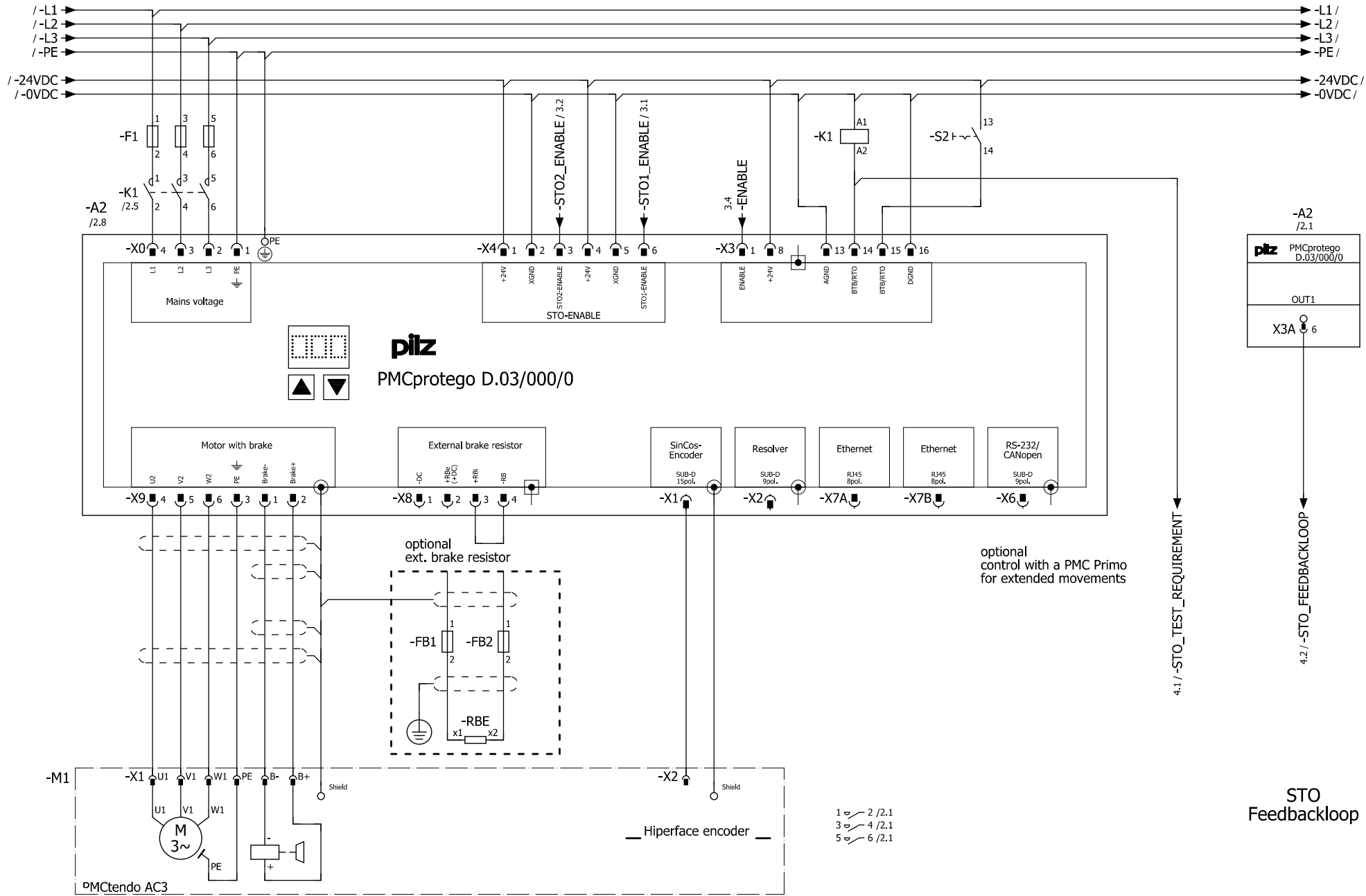

4.1 / -STO_TEST_REQUIREMENT

4.2 / -STO_FEEDBACKLOOP

STO Feedbackloop

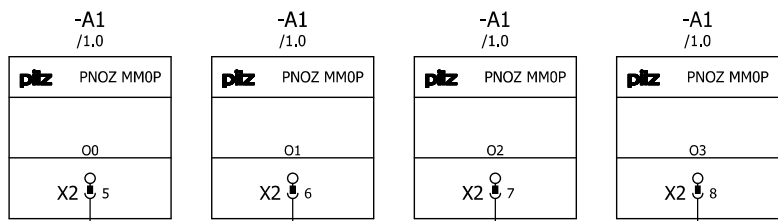

STO1
Enable

STO2
Enable

STO Feedbackloop
Test OK

Enable

to
standard
control

Revision	17.03.2011	Date	29.10.2010
Name	RDS	Name	RDS
		Dep.	CS

EN ISO 13849-1:2006 PL e
EN 62061:2005 SIL 3

pilz Pilz GmbH & Co. KG
Felix-Wankel-Strasse 2
D-73760 Ostfildern

PNOZmulti Mini OUT

Mounting place + AN_1002189_01
Page: 3 / 4

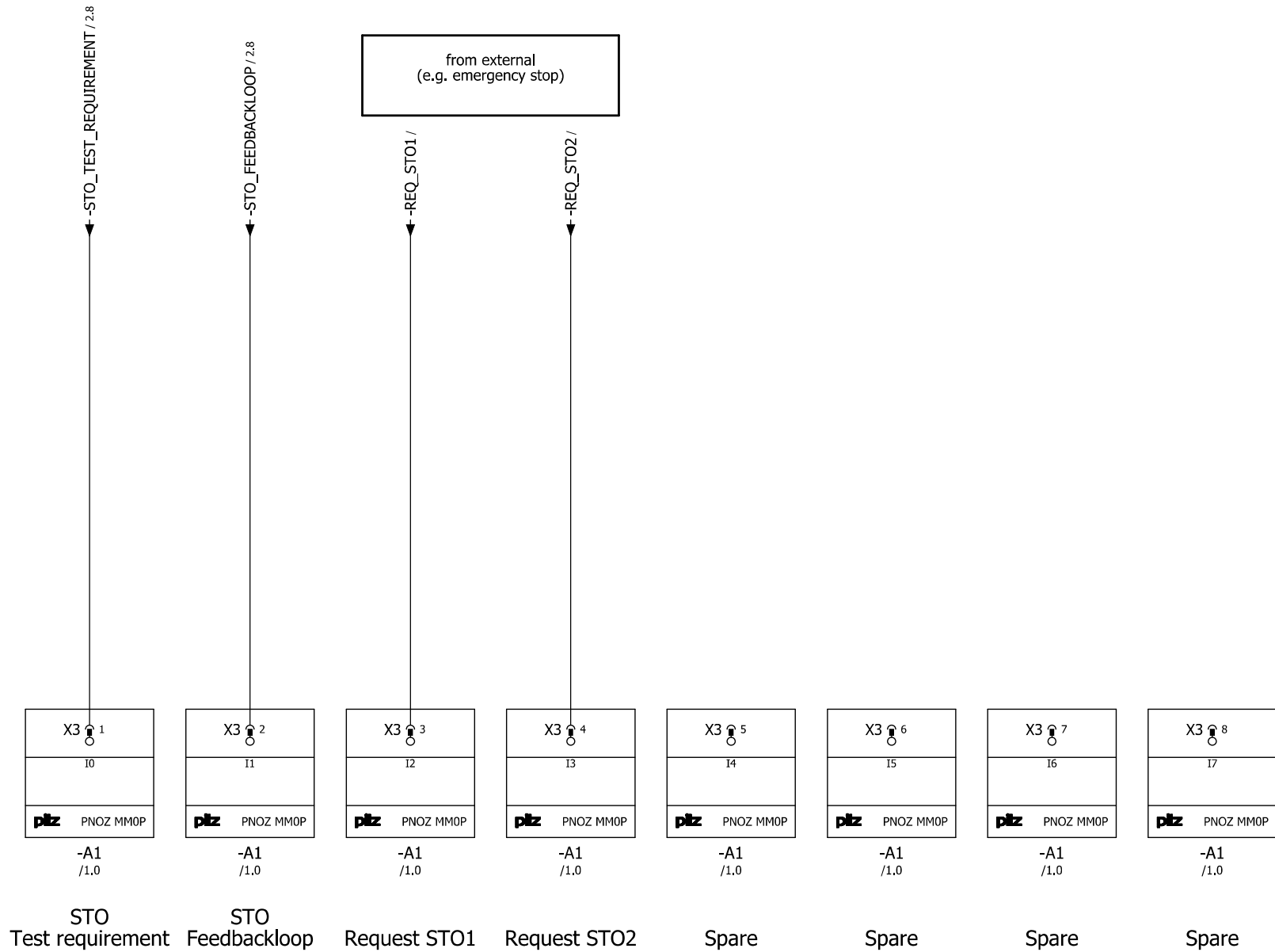

Recommended printer settings

Adobe Acrobat Reader (www.adobe.com)

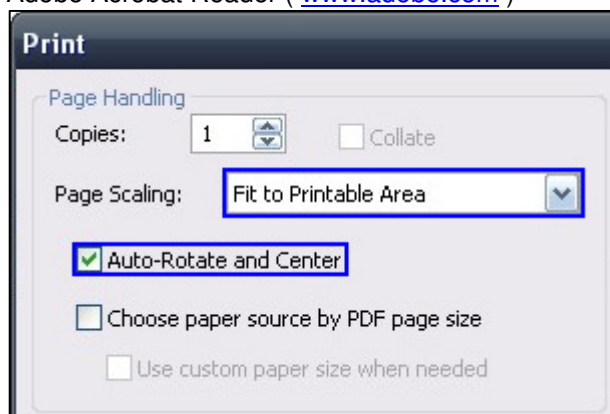

PDF-XChange Viewer (www.tracker-software.com)

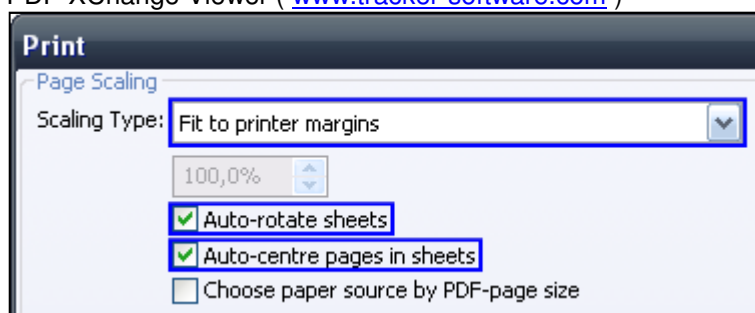



► ...
In many countries we are represented by our subsidiaries and sales partners.

Please refer to our homepage for further details or contact our headquarters.

Pilz GmbH & Co. KG
Felix-Wankel-Straße 2
73760 Ostfildern, Germany
Telephone: +49 711 3409-0
Telefax: +49 711 3409-133
E-Mail: pilz.gmbh@pilz.de
Internet: www.pilz.com

► Technical support

+49 711 3409-444
support@pilz.com

pilz