

PSS 4000 Safety Gate with PSENmech (me2) Structured Text



Product

Type: FS_SafetyGate, FS_OutputFBL
Name: PSS 4000, Blocks, PAS4000, PLC, STL
Manufacturer: Pilz GmbH & Co. KG, Safe Automation

Document

Release Number: 01
Release Date: 23 April 2012

Document Revision History

Release	Date	Changes	Chapter
01	2012-04-23	Creation	all

Exclusion of liability

We have taken great care in compiling our application note. It contains information about our company and our products. All statements are made in accordance with the current status of technology and to the best of our know-ledge and belief.

However, we cannot accept liability for the accuracy and entirety of the information provided, except in the case of gross negligence. In particular it should be noted that statements do not have the legal quality of assurances or assured properties.

We are grateful for any feedback on the contents.

April 2012

All rights to this publication are reserved by Pilz GmbH & Co. KG. We reserve the right to amend specifications without prior notice. Copies may be made for the user's internal purposes. The names of products, goods and technologies used in this manual are trademarks of the respective companies.

Support

Technical help round the clock!

Technical support is available from Pilz round the clock.

This service is provided free of charge beyond standard business hours.

Americas

- ▶ Brazil
+55 11 8245-8267
- ▶ Mexico
+52 55 5572 1300
- ▶ USA (toll free)
+1 877-PILZUSA (745-9872)

Asia

- ▶ China
+86 21 62494658-216
- ▶ Japan
+81 45 471-2281
- ▶ Korea
+82 2 2263 9540

Australia

- ▶ Australia
+61 3 95446300

Europe

- ▶ Austria
+43 1 7986263-0
- ▶ Belgium, Luxembourg
+32 9 3217575
- ▶ England
+44 1536 462203
- ▶ France
+33 3 88104000
- ▶ Germany
+49 711 3409-444
- ▶ Ireland
+353 21 4804983
- ▶ Italy
+39 031 789511
- ▶ Scandinavia
+45 74436332
- ▶ Spain
+34 938497433
- ▶ Switzerland
+41 62 88979-30
- ▶ The Netherlands
+31 347 320477
- ▶ Turkey
+90 216 5775552

You can reach our international hotline on:

+49 711 3409-444 or <mailto:support@pilz.com>

Pilz GmbH & Co. KG
Safe Automation
Felix-Wankel-Straße 2
73760 Ostfildern, Germany

Telephone: +49 711 3409-0
Telefax: +49 711 3409-133
E-Mail: pilz.gmbh@pilz.de
Internet: www.pilz.com

Contents

1. Useful documentation	6
1.1. Documentation from Pilz GmbH & Co. KG	6
1.2. Documentation from other sources of information	6
2. Hardware configuration.....	7
2.1. Pilz products.....	7
2.2. Hardware configuration	7
3. Application Task	8
3.1. Description	8
3.1.1. Safety gate monitoring function	8
3.1.2. Feedback loop monitoring function.....	10
3.2. Functional safety	11
3.2.1. Safety-related characteristics in accordance with EN ISO 13849-1	11
3.2.2. Safety-related characteristics in accordance with EN 62061	12
3.3. PAS-Project.....	13
3.3.1. IEC 61131 Programming	13
3.3.2. I/O Mapping	17
3.3.3. Process PAS Project	18
3.4. Circuit diagram of the application.....	21
3.4.1. Circuit diagram 1/4.....	21
3.4.2. Circuit diagram 2/4.....	22
3.4.3. Circuit diagram 3/4.....	23
3.4.4. Circuit diagram 4/4.....	24
4. Table of figures	25

Abbreviations

PAS	P ilz A utomation S uite (software platform)
PSS	Programmable control system (DE: P rogrammierbares S teuerungssystem)
PNOZ	Pilz E-STOP Positive-guided (DE: P ilz N OT-AUS-Zwangsgeführt)
POU	P rogram O rganisation U nit
PRG	P rogram
FB	F unction B lock
FUN	F unction
STL (ST)	S tructured T ext L anguage

1. Useful documentation

Reading the documentation listed below is necessary for understanding this application note. The availability of the indicated tools and safe handling are also presupposed with the user.

1.1. Documentation from Pilz GmbH & Co. KG

No.	Description	Item No.
1	Pilz international homepage, download section	www.pilz.com
2	Operating Manual PSSu H PLC1 FS SN SD	21939-EN-xx
3	Operating Manual PSSu E F 4DI	21 311-xx
4	Operating Manual PSSu E F DI OZ 2	21 329-xx
5	Operating Manual PSSu E F 4DO 0.5	21 317-xx
6	Operating Manual PSSu E S 4DI	21 340-EN-xx
7	Operating Manual PSSu E S 4DO 0.5	21 346-EN-xx
8	System Description Programmable safety and control system PSS 4000	1001467-EN-xx
9	Safety Manual Programmable safety and control system PSS 4000	1001468-EN-xx
10	PAS4000 online help	-
11	Operating Manual PSEN me2S/2AS	0800000423_en

1.2. Documentation from other sources of information

No.	Description	Item No.
1		
2		

Note

The present example (PSS 4000 Safety Gate with PSENmech) is also available in the programming languages [Instruction list](#) and [PASmulti](#).

2. Hardware configuration

2.1. Pilz products

No.	Description	Order number	Version	Number
1	PSSu H PLC1 FS SN SD	312 070	001	1
2	PSSu E F 4DI	312 200	-	1
3	PSSu E F DI OZ 2	312 220	-	1
4	PSSu E F 4DO 0.5	312 210	-	2
5	PSSu E S 4DI	312 400	-	1
6	PSSu E S 4DO 0.5	312 405	-	1
7	PSSu BP 1/8 C	312 601	-	6
8	PSENme 2S/2AS	570 200	-	2
9	PAS4000	-	v1.5.0	1

2.2. Hardware configuration

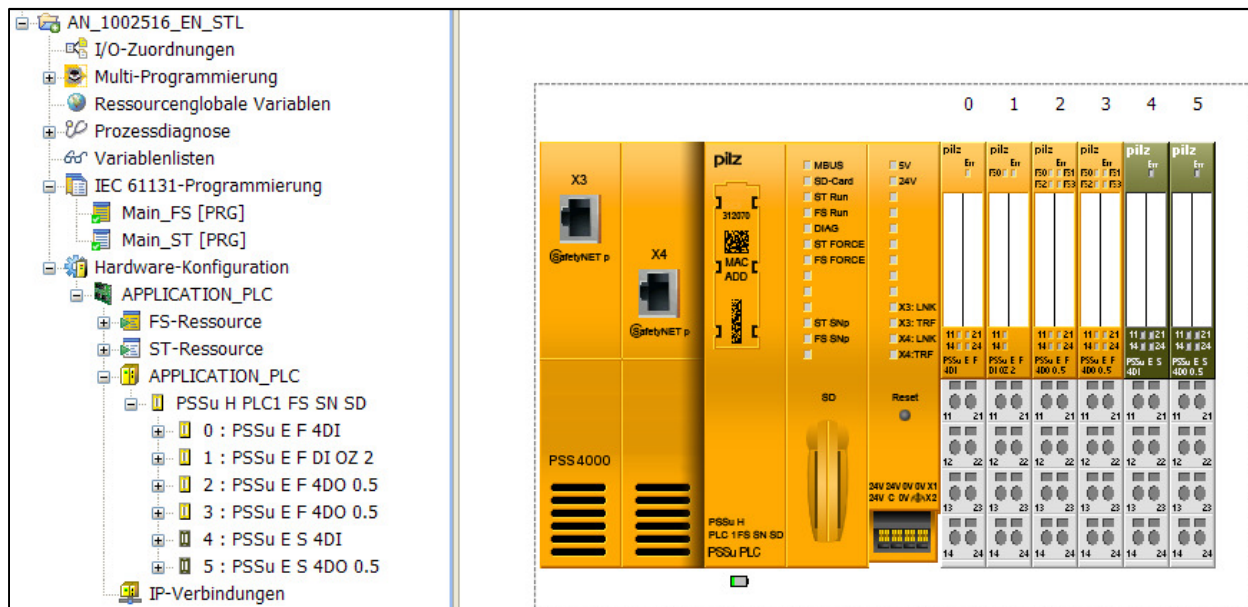

Fig. 1: Hardware configuration

3. Application Task

3.1. Description

The example shows the implementation of a safety gate application with a PSS 4000 PLC. The safe control and evaluation of the signals is taken over by two Pilz Function blocks (FS-FB) from the library.

- ▶ FS_SafetyGate
CRC ADDB

- ▶ FS_OutputFBL
CRC B3A7

The workflow is divided into the following two main functions:

- ▶ Safety Gate and
- ▶ Feedback Loop Monitoring

3.1.1. Safety gate monitoring function

The control system monitors the two safety gate switches (S1, S2) via the user program. An instance of the Pilz function block “FS_SafetyGate” is assigned to them. This FS-FB detects whether the assigned safety gate switch has been operated, as well as detecting incorrect input signals and whether the contact synchronization time has been exceeded, etc.

If the safety gate switches are operated or an error occurs, the enable output “Enable” on the FS-FB will immediately be reset.

The enable output “Enable” is also reset when the PSS is stopped and when the PSS is switched on. The signal from the enable output “Enable” must be evaluated by the user program and trigger an appropriate reaction.

Based on the diagnostic outputs (“DiagSwitchError”, “DiagInputNotValid”) it can be determined why “Enable” was reset.

The outputs “DiagOperated”, “DiagReadyForReset” and “DiagReadyForTest” are used as status messages.

A “valid bit” is formed by the system for the respective hardware input to determine whether a process value received from a sensor is valid.

The valid bit is queried in the Function block and indicates whether an error has occurred in the signal transmission between hardware input and processor (such as test clock error, module overheats, etc.).

If the valid bit is FALSE, the process value is invalid and the Pilz function block provides an appropriate diagnostic message. The error signal reset enable.

(For more information, see “Validity process data” in PAS4000 online help)

The way in which the error is reset will depend on the operating mode set on the FS-FB. In this application example, parameters for FS-FB have been set in such a way that “Reset” (S3) is required in order to reset output parameter “Enable” when:

- the PSS is cold started (PSS switched from off to on),
- warm started (PSS transferring from STOP to RUN) or
- when the safety gate switches are released.

Although the safety gate functions are configured to reset themselves, a PSS cold start or the closing of the safety gate may not directly enable a machine to start up without further conditions being met.

Input circuit safety assessment

- ▶ If a contact on the safety gate switch is overridden, the Pilz function block will detect this as an error at the next operation.
- ▶ A short between the input circuits within a multicore cable will be detected as an error by the programmable control system.
- ▶ A short between 24 VDC and an input circuit will be detected as an error by the programmable control system.
- ▶ The highest category can only be achieved when the contacts on the safety gate switch are supplied with test pulses and the contacts on the safety gate switch have dual-channel wiring.
- ▶ If an operator completely (or even maybe partly) is able to access the dangerous area, a risk analysis should clarify whether an additional, separate “manual reset function” is required.

3.1.2. Feedback loop monitoring function

The control system monitors the feedback circuits (NC contacts) of the motor contactors KM1 and KM2 via the user program.

An instance of the Pilz function block “FS_OutputFBL” is assigned to them.

The FS_FB drives the contactors as well as monitoring the feedback loop.

A 1-signal at input parameter “Input” of the FS-FB sets the outputs that drive the contactors, “Output1” and “Output2”, to “1”; a 0-signal sets it to “0”.

If an error occurs, the outputs “Output1” and “Output2” that drive the contactors on FS-FB will immediately be reset. Both outputs are also reset when the PSS is stopped and when the PSS is switched on.

Based on the diagnostic outputs (“DiagFeedbackLoopError”, “DiagFeedbackLoopNotValid”) it can be determined why the outputs were reset.

A “valid bit” is formed by the system for the respective hardware input to determine whether a process value received from a sensor is valid.

The valid bit is queried in the Function block and indicates whether an error has occurred in the signal transmission between hardware input and processor (such as test clock error, module overheats, etc.).

If the valid bit is FALSE, the process value is invalid and the Pilz function block provides an appropriate diagnostic message. The error signal reset enable.

(For more information, see “Validity process data” in PAS4000 online help)

If an error occurs, a new activity has to take place at the input “Input” of the FS-FB once the error has been rectified, so that the outputs “Output1” and “Output2” will be set again.

Feedback loop monitoring safety assessment

- ▶ A short between 24 VDC and a safety output or a feedback loop input will be detected as an error by the programmable safety system. The load can be switched off via the second shutdown route.
- ▶ The feedback loop contacts must be installed in a single mounting area (control cabinet).
- ▶ To achieve a higher level of safety, 2 actuators must be used.

3.2. Functional safety

3.2.1. Safety-related characteristics in accordance with EN ISO 13849-1

No.	Safety function	PL	Safety-related parts of the control system
1	Machine shut down when a safety gate is opened	PL e	Sensor (PSEN me 2S/2AS S1, S2) Input (PSSu E F 4DI) Logic (PSSu H PLC1 FS SN) Output (PSSu E F DI OZ 2) Actuator (contactors KM1, KM2)

Prerequisites

No.	Description	Identification	
1	Common cause failure (CCF)	Requirements are considered to be met (must be tested on implementation)	
2	Mission time	20 years	
3	Operating interval (electromechanical components)	Sensor	two operations per hour
		Actuator	two operations per hour
4	Characteristic data of contactors KM1/KM2	B10d	2,000,000

Please note the further requirements of EN ISO 13849-1, e.g. requirements for avoiding systematic faults.

3.2.2. Safety-related characteristics in accordance with EN 62061

No.	Safety-related control function (SFCF)	Safety Integrity Level	Subsystems
1	Machine shut down when a safety gate is opened	SIL 3	Sensor (PSEN me 2S/2AS S1, S2) Input (PSSu E F 4DI) Logic (PSSu H PLC1 FS SN) Output (PSSu E F DI OZ 2) Actuator (contactors KM1, KM2)

Prerequisites

No.	Description	Identification	
1	Common cause failure (CCF)	$\beta = 2\%$ (must be tested on implementation)	
2	Proof test interval	20 years	
3	Operating interval (electromechanical components)	Sensor	two operations per hour
		Actuator	two operations per hour
4	Characteristic data of contactors KM1/KM2	B10d	2,000,000
		Dangerous failure rate	65%

Please note the further requirements of EN 62061, e.g. requirements for systematic safety integrity.

3.3. PAS-Project

To operate a plant with one or more programmable control systems PSS 4000, a project must be created in PAS4000.

A project consists of the hardware configuration and the user program.

3.3.1. IEC 61131 Programming

When programming in accordance with IEC 61131, the user program is structured by three types of program organisation units (POUs):

- ▶ Programs (PRG)
- ▶ Function blocks (FB)
- ▶ Functions (FUN)

The program forms the higher structural level. Functions and function blocks may be called up within a program.

Function blocks and functions undertake specific individual tasks within the program.

Each POU consists of a declaration part and an instruction part.

The variables and type declarations are made in the declaration part, which is shown in text format, irrespective of the programming language.

The instruction part contains the instructions. The instructions can be formulated in one of the IEC 61131 programming languages.

(For more information about programming with PAS4000, look at PAS4000 online help)

3.3.1.1. STL-Editor

The program for the cyclic process is created in a POU of the type “Program”.
The Pilz function blocks for safety gate and feedback loop were added from the library. (Right-click in the declaration part of the POU “Add library Element”).

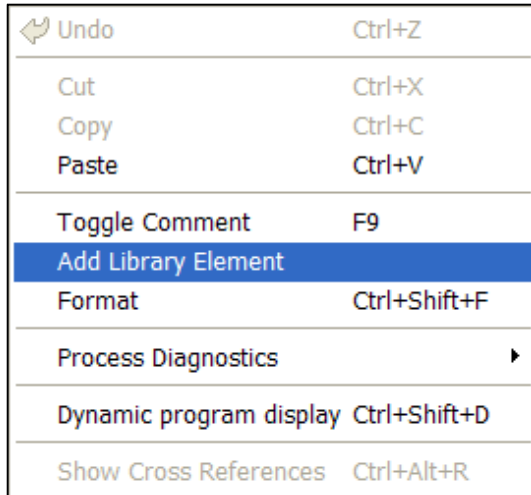

Fig. 2: Add library element

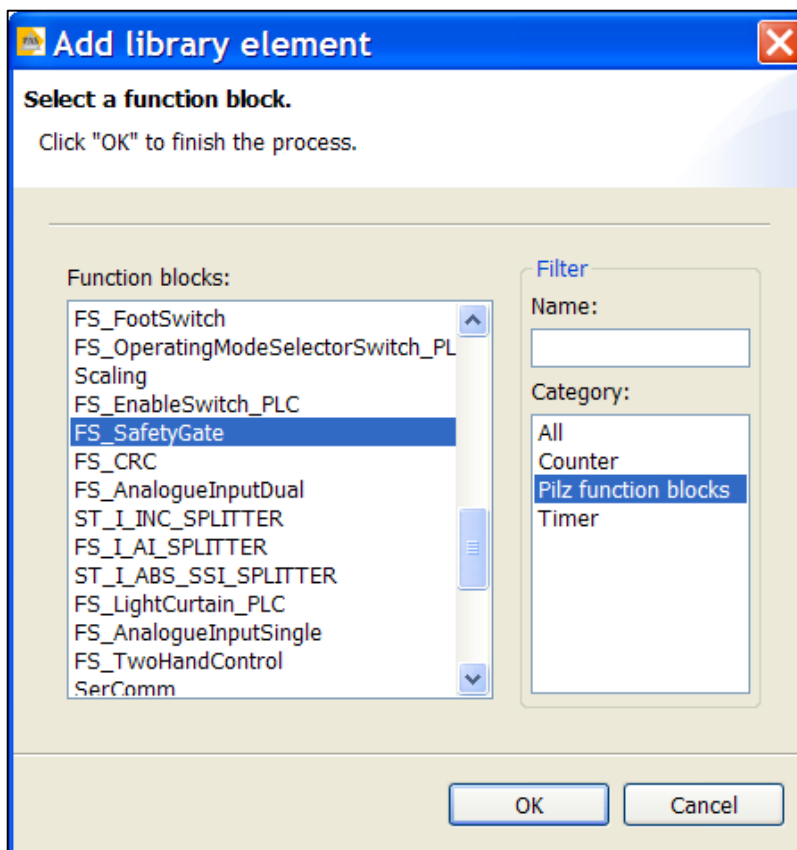

Fig. 3: Selection library element

Failsafe program

Declaration part

```
001 PROGRAM Main_FS
002 VAR
003 // My SGATE 1
004 MySafetyGatel : FS_SafetyGate;
005 MySGatel_Enable AT %Q* : SAFEBOOL;
006 MySGatel_DiagOperated AT %Q* : SAFEBOOL;
007 MySGatel_DiagReadyForReset AT %Q* : SAFEBOOL;
008 MySGatel_DiagReadyForTest AT %Q* : SAFEBOOL;
009 MySGatel_DiagSwitchError AT %Q* : SAFEBOOL;
010 MySGatel_DiagInputNotValid AT %Q* : SAFEBOOL;
011
012 // My FBL
013 MyFeedBackLoop1 : FS_OutputFBL;
014 MyFBL1_DiagFblError AT %Q* : SAFEBOOL;
015 MyFBL1_DiagFblNotValid AT %Q* : SAFEBOOL;
016 END_VAR
017
018 VAR CONSTANT
019 // Declaration SwitchType 3 (NCNC)
020 MySGATE1_DOUBLE_CH : USINT := USINT#3;
021 END_VAR
```

Instruction part

```
022 // Safety-Block Emergency-Stop1
023 MySafetyGatel(
024 SwitchType := MySGATE1_DOUBLE_CH,
025 AutoStart := FALSE,
026 AutoReset := FALSE,
027 MonitoredReset := TRUE,
028 StartupTest := FALSE,
029 SimultaneityTime := T#100ms,
030 DelayTime := T#40ms,
031 Enable => MySGatel_Enable,
032 DiagOperated => MySGatel_DiagOperated,
033 DiagReadyForReset => MySGatel_DiagReadyForReset,
034 DiagReadyForTest => MySGatel_DiagReadyForTest,
035 DiagSwitchError => MySGatel_DiagSwitchError,
036 DiagInputNotValid => MySGatel_DiagInputNotValid);
037
038 // Safety-Block monitoring FBL1 and release motor1
039 MyFeedBackLoop1(
040 Input := MySGatel_Enable,
041 FeedbackLoopTime := T#200ms,
042 DiagFeedbackLoopError => MyFBL1_DiagFblError,
043 DiagFeedbackLoopNotValid => MyFBL1_DiagFblNotValid);
044
045 END_PROGRAM
```

Standard program

The signals from the start- and stop switch are imported from a standard module PSSu E S 4DI (1A4). These signals belong to the motor control and thus to the standard control functions of the machine.

The program code for the evaluation and processing of these signals is not processed within the FS resource (safety-related part) of the control, but in a ST resource in a separate task as independent application (additional POU of type program).

Declaration part

```
001 PROGRAM Main_ST
002 VAR
003     MyRisingEdge1          : R_TRIG;
004     Start                  AT %I* : BOOL;
005     Stop                   AT %I* : BOOL;
006     Motor1_On              AT %Q* : BOOL;
007     Other_Stop_Conditions AT %I* : BOOL;
008     FF_Motor1On           : RS;
009 END_VAR
```

Instruction part

```
010 // Rising Edge 1 - Monitoring Start
011 MyRisingEdge1(clk := Start);
012
013 // Flip-Flop Motor1 On
014 FF_Motor1On(set := MyRisingEdge1.q (*AND Other_Start_Conditions {e.g.
                                     Operating Mode} *),
015             reset1 := NOT Stop OR NOT Other_Stop_Conditions (* e.g.
                                                                Enable signal from SGate1 *),
016             q1 => Motor1_On);
017
018 END_PROGRAM
```

3.3.2. I/O Mapping

In PAS4000, variables can be created and the user program can be programmed without the need of the mapping to the hardware being present at the beginning of the project.

After identification of the used I/O from the variable declaration, the required hardware can be determined.

The I/O mapping editor forms the connecting between the user program and the hardware and coordinates the available I/O and existing PI-variables.

3.3.2.1. I/O Mapping Editor

The PI variables declared in the user-program can be assigned in the I/O mapping editor to the hardware configuration.

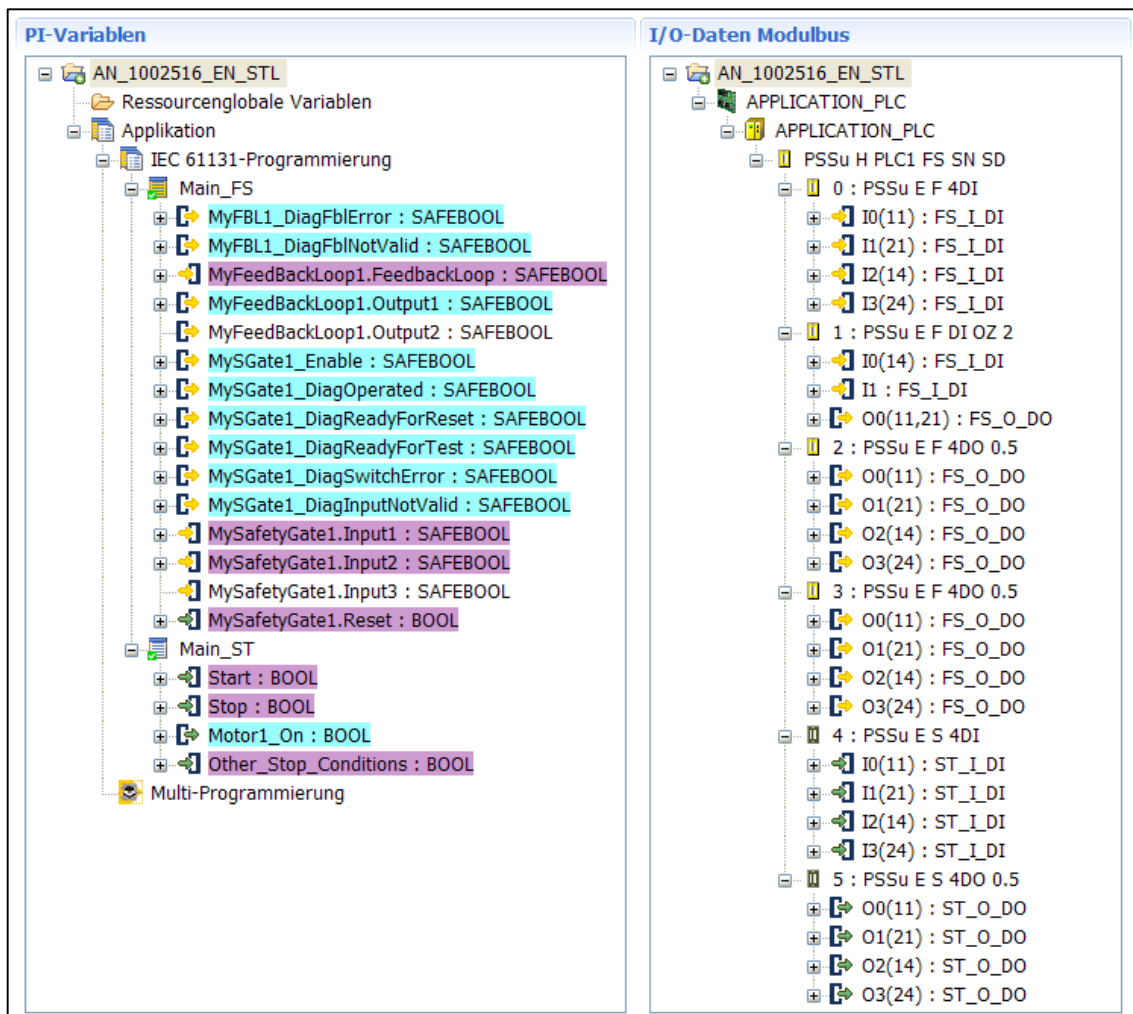

Fig. 4: Mapping Editor – STL-program

3.3.3. Process PAS Project

- ▶ Step 1: In the STL editor, PI variables and the logical sequence will be generated as a program.

```
PROGRAM Main_FS
VAR
  MySGate1_DiagInputNotValid AT %Q* : SAFEBOOL;
  MyFBL1_DiagFblError        AT %Q* : SAFEBOOL;
```

Fig. 5: PI variables

- ▶ Step 2: The design of the hardware (control, I/O, sensor, actor) will created as a circuit diagram. (parallel possible to Step 1)

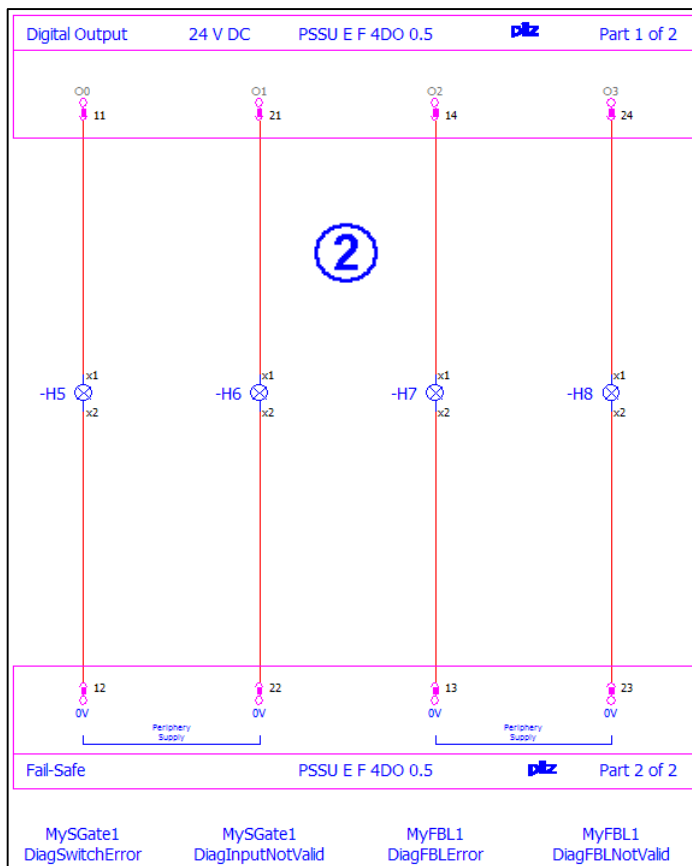

Fig. 6: Circuit diagram (extract)

- ▶ Step 3: Based on the PI variables (I/O), the required power of control (PLC, Multi) is selected. The implementation of the I/O modules in the PAS system occurs in the PSSu module editor.

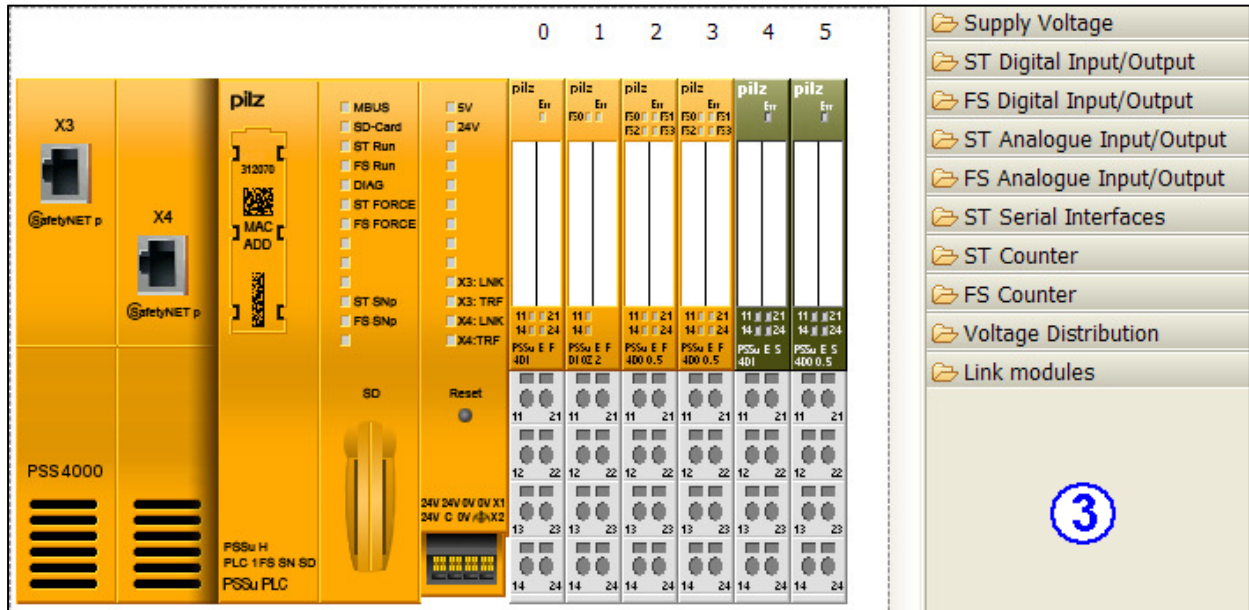

Fig. 7: PSSu Module Editor

- ▶ Step 4: Assignment of the PI variables in the I/O Mapping Editor.

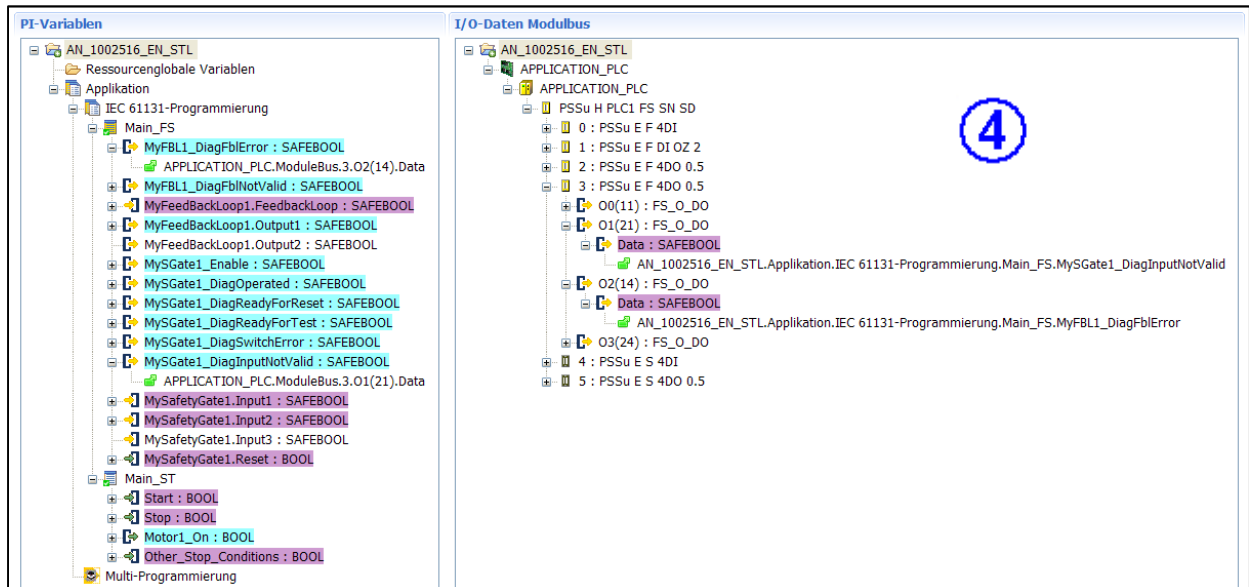

Fig. 8: I/O Mapping Editor

► Overview process PAS Project (Steps 1-4)

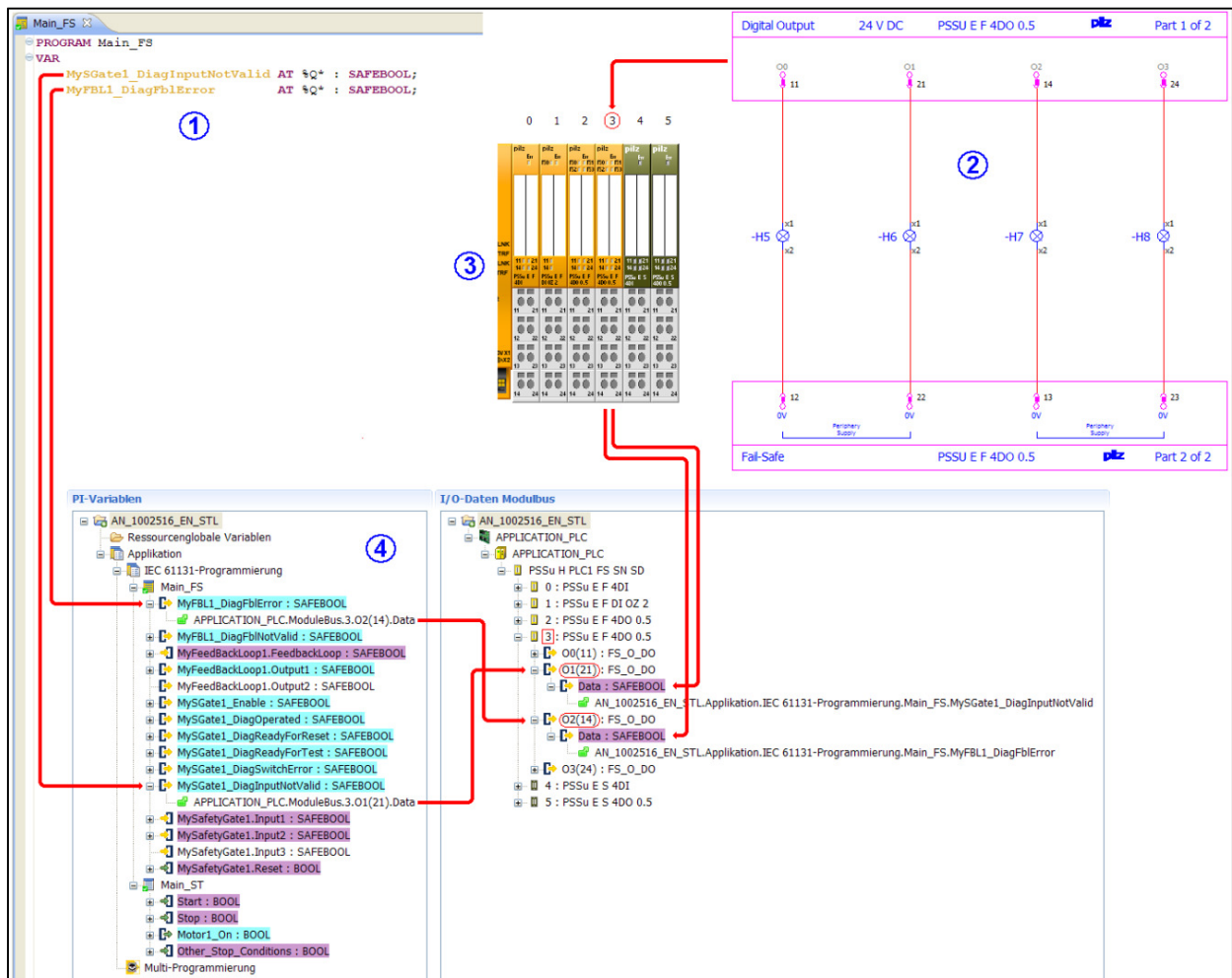
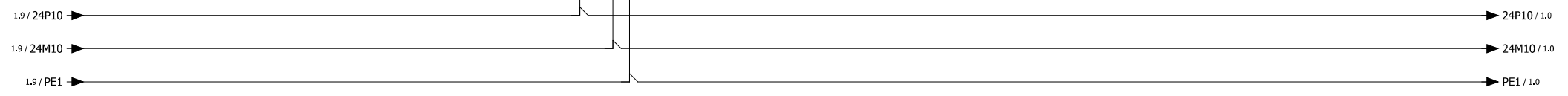
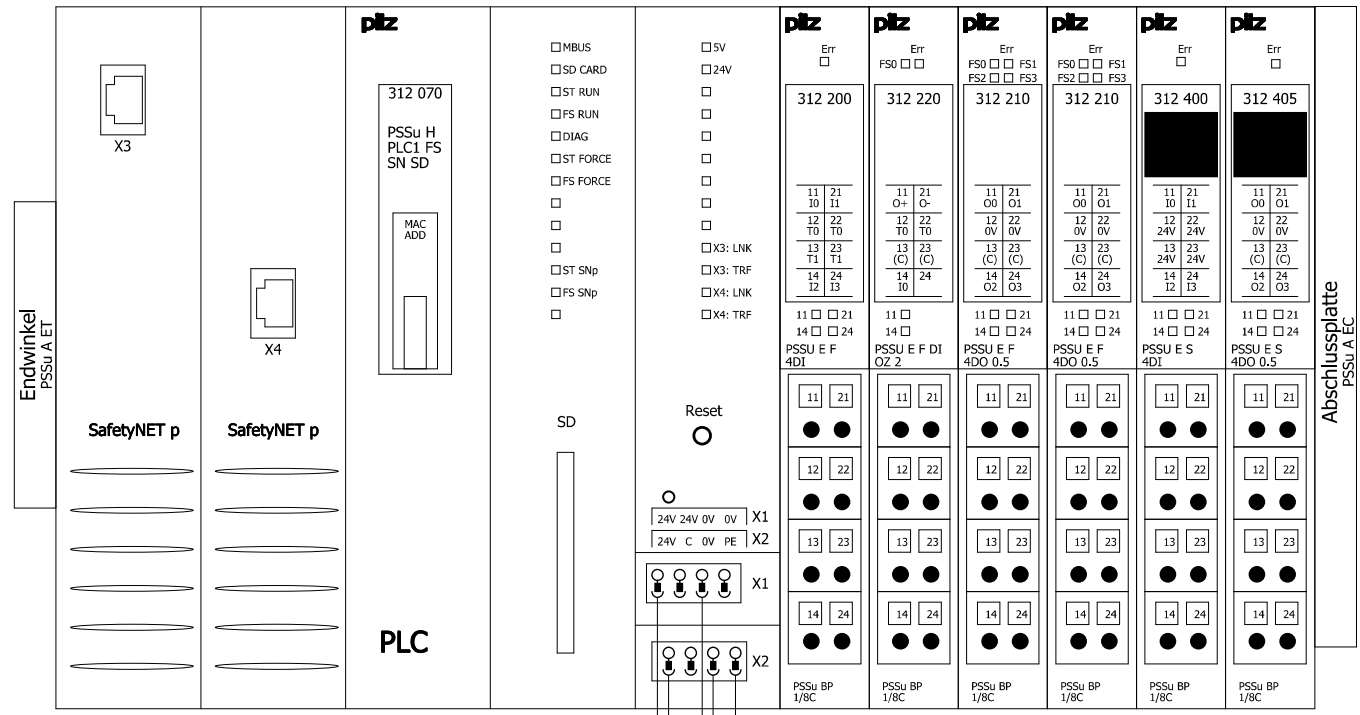
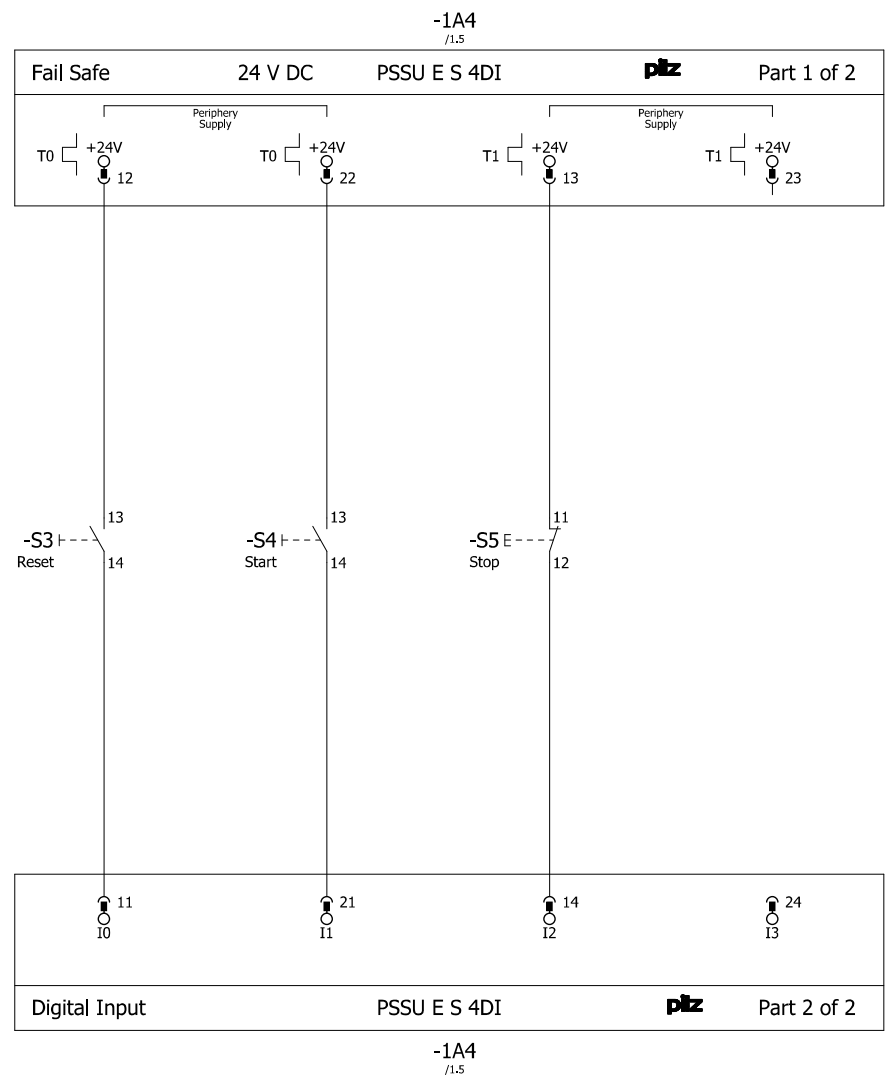
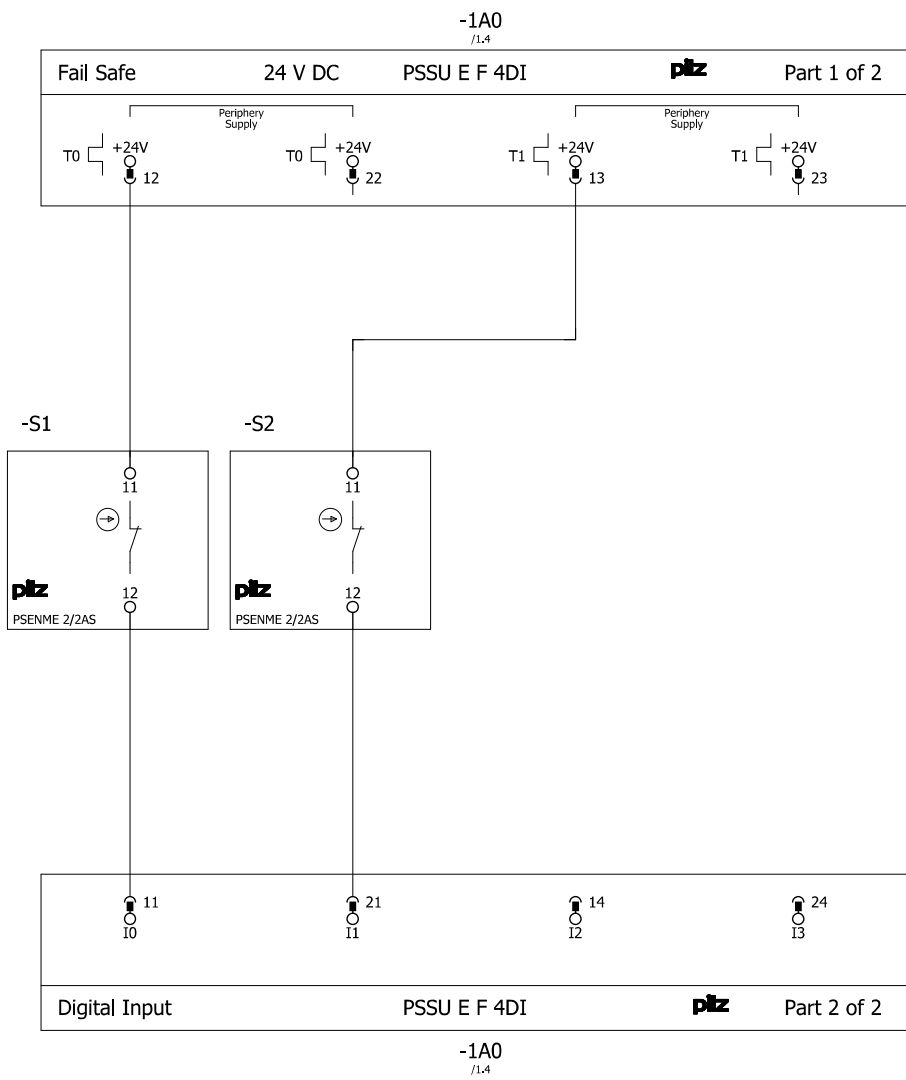

Fig. 9: Process PAS Project

-1A -1A0 -1A1 -1A2 -1A3 -1A4 -1A5



- PSSu E F 4DI 312 200
- PSSu E S 4DI 0.5 312 400
- PSSu E S 4DI 0.5 312 400
- PSSu E F DI OZ 2 312 220
- PSSu E S 4DO 0.5 312 405
- PSSu E S 4DO 0.5 312 405
- PSSu BP 1/8C 312 601
- PSSu BP 1/8C 312 601
- PSSu BP 1/8C 312 601
- PSSu BP 1/8C 312 601
- PSSu BP 1/8C 312 601
- PSSu BP 1/8C 312 601



MySafetyGate1
Input1

MySafetyGate1
Input2

Spare

Spare

MySafetyGate1
Reset

Start

Stop

Spare

Revision	08.03.2012	Date	19.01.2005
Name	RDS	Name	RDS
		Dep.	CS

EN ISO 13849-1:2006 PL e
EN 62061:2005 SIL 3

pilz Pilz GmbH & Co. KG
Felix-Wankel-Str.2
73760 Ostfildern

PSS 4000 - Safety Gate with PSENmech
Inputs

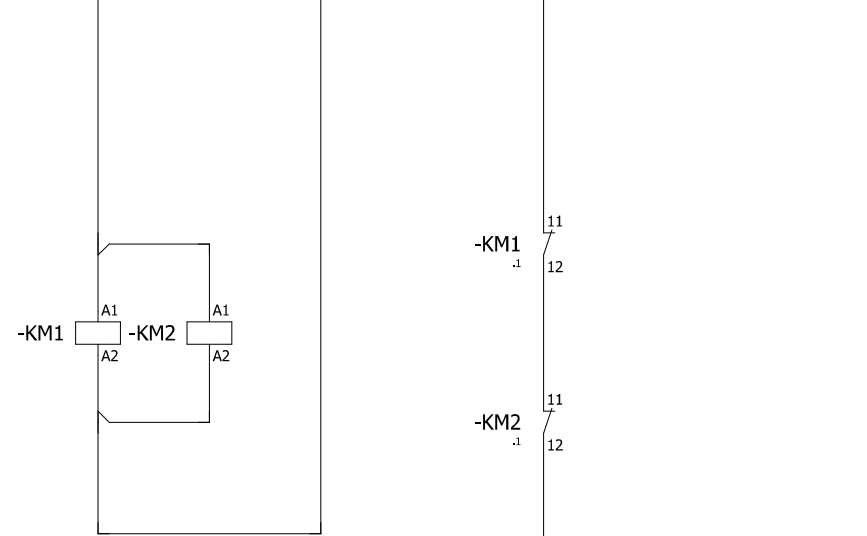
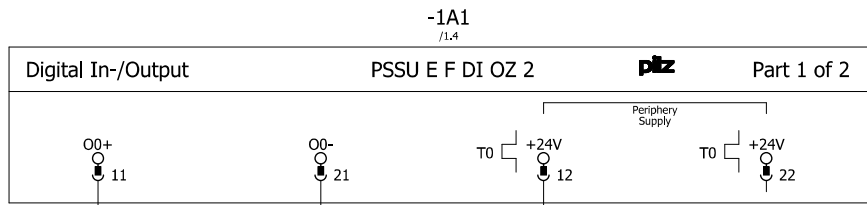

MyFeedBackLoop1
Output1

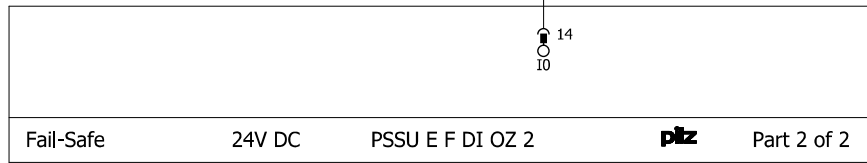

-1A1
/1.4

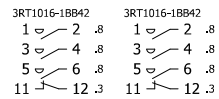

MyFeedBackLoop1
FeedbackLoop

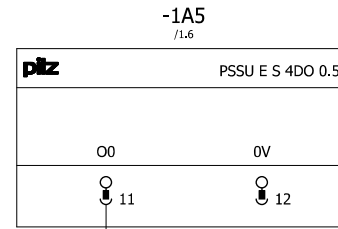

-1A5
/1.6

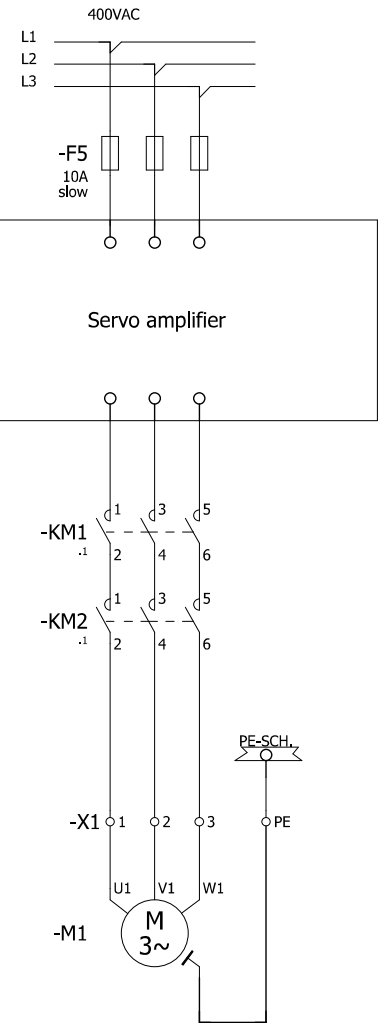

Motor1_On

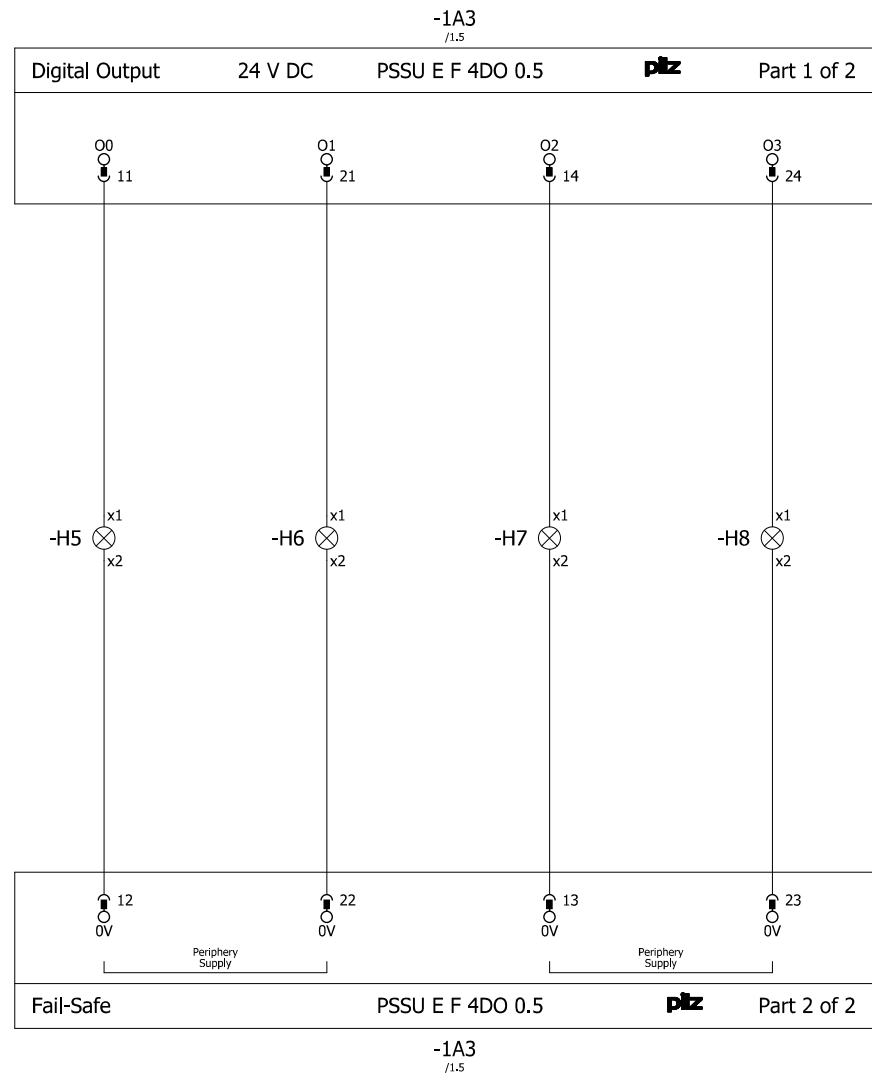
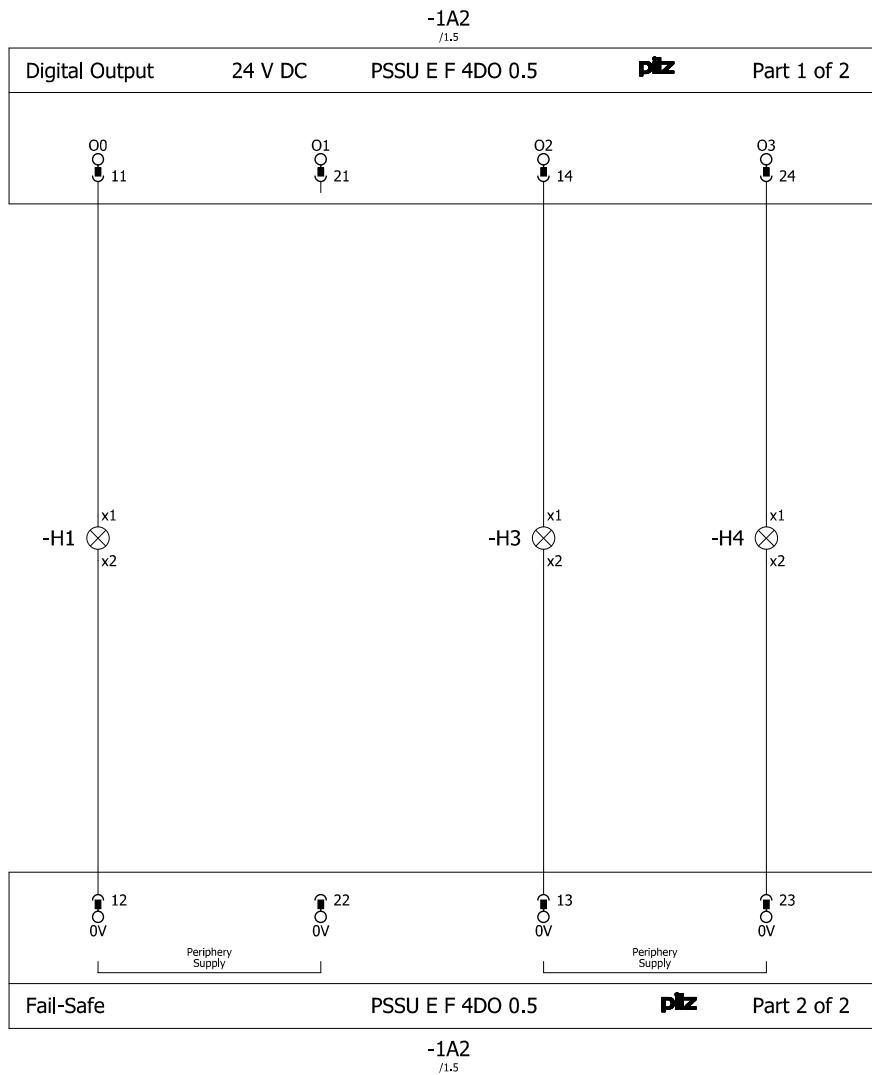

MySGate1
DiagOperated

Spare

MySGate1
DiagReadyForReset

MySGate1
DiagReadyForTest

MySGate1
DiagSwitchError

MySGate1
DiagInputNotValid

MyFBL1
DiagFBLError

MyFBL1
DiagFBLNotValid

Revision	08.03.2012	Date	19.01.2005
Name	RDS	Name	RDS
		Dep.	CS

EN ISO 13849-1:2006 PL e
EN 62061:2005 SIL 3



PSS 4000 - Safety Gate with PSENmech
Status/Error message

Mounting place + AN_1002024_02
Page: 4 / 4

4. Table of figures

Fig. 1: Hardware configuration	7
Fig. 2: Add library element	14
Fig. 3: Selection library element.....	14
Fig. 4: Mapping Editor – STL-program.....	17
Fig. 5: PI variables	18
Fig. 6: Circuit diagram (extract).....	18
Fig. 7: PSSu Module Editor.....	19
Fig. 8: I/O Mapping Editor	19
Fig. 9: Process PAS Project.....	20

Recommended printer settings

Adobe Acrobat Reader (www.adobe.com)

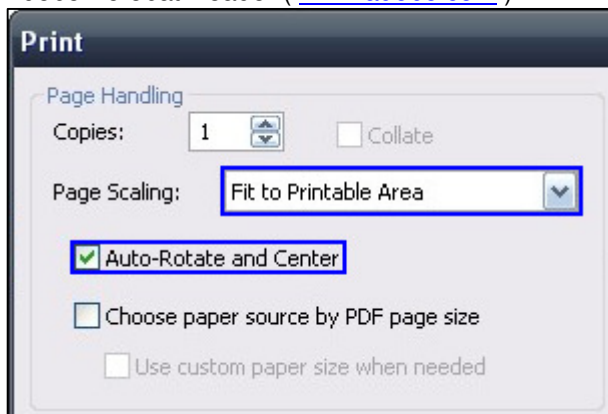

PDF-XChange Viewer (www.tracker-software.com)

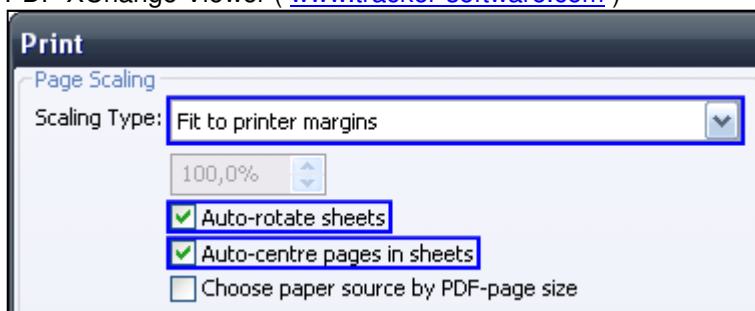



► ...
In many countries we are represented by our subsidiaries and sales partners.

Please refer to our homepage for further details or contact our headquarters.

Pilz GmbH & Co. KG
Felix-Wankel-Straße 2
73760 Ostfildern, Germany
Telephone: +49 711 3409-0
Telefax: +49 711 3409-133
E-Mail: pilz.gmbh@pilz.de
Internet: www.pilz.com

► Technical support

+49 711 3409-444
support@pilz.com

pilz