



## PNOZ m ES 14DO

**PILZ**  
THE SPIRIT OF SAFETY

- ▶ Configurable, safe small controllers PNOZmulti 2

This document is the original document.

Where unavoidable, for reasons of readability, the masculine form has been selected when formulating this document. We do assure you that all persons are regarded without discrimination and on an equal basis.

All rights to this documentation are reserved by Pilz GmbH & Co. KG. Copies may be made for the user's internal purposes. Suggestions and comments for improving this documentation will be gratefully received.

Pilz®, PIT®, PMI®, PNOZ®, Primo®, PSEN®, PSS®, PVIS®, SafetyBUS p®, SafetyEYE®, SafetyNET p®, the spirit of safety® are registered and protected trademarks of Pilz GmbH & Co. KG in some countries.



SD means Secure Digital

<b>1</b>	<b>Introduction</b>	<b>4</b>
1.1	Validity of documentation	4
1.2	Using the documentation	4
1.3	Definition of symbols	4
1.4	Third-party manufacturer licence information	5
<b>2</b>	<b>Overview</b>	<b>6</b>
2.1	Scope of supply	6
2.2	Unit features	6
2.3	Front view	7
<b>3</b>	<b>Safety</b>	<b>8</b>
3.1	Intended use	8
3.2	System requirements	8
3.3	Safety regulations	9
3.3.1	Use of qualified personnel	9
3.3.2	Warranty and liability	9
3.3.3	Disposal	9
3.3.4	For your safety	9
<b>4</b>	<b>Function description</b>	<b>10</b>
4.1	Functions	10
4.2	System reaction time	10
4.3	Block diagram	10
<b>5</b>	<b>Installation</b>	<b>11</b>
5.1	General installation guidelines	11
5.2	Dimensions in mm	11
5.3	Connecting the base unit and expansion modules	12
<b>6</b>	<b>Commissioning</b>	<b>13</b>
6.1	General wiring guidelines	13
6.2	Connection	13
<b>7</b>	<b>Operation</b>	<b>14</b>
7.1	Messages	14
<b>8</b>	<b>Technical details</b>	<b>15</b>
<b>9</b>	<b>Order reference</b>	<b>18</b>
9.1	Product	18
9.2	Accessories	18
9.2.1	Replacement terminals	18
9.2.2	Connector plug	18

# 1 Introduction

## 1.1 Validity of documentation

This documentation is valid for the product PNOZ m ES 14DO from Version HW:01, FW:01.00.

This operating manual explains the function and operation, describes the installation and provides guidelines on how to connect the product.

## 1.2 Using the documentation

This document is intended for instruction. Only install and commission the product if you have read and understood this document. The document should be retained for future reference.

## 1.3 Definition of symbols

Information that is particularly important is identified as follows:



### **DANGER!**

This warning must be heeded! It warns of a hazardous situation that poses an immediate threat of serious injury and death and indicates preventive measures that can be taken.



### **WARNING!**

This warning must be heeded! It warns of a hazardous situation that could lead to serious injury and death and indicates preventive measures that can be taken.



### **CAUTION!**

This refers to a hazard that can lead to a less serious or minor injury plus material damage, and also provides information on preventive measures that can be taken.



### **NOTICE**

This describes a situation in which the product or devices could be damaged and also provides information on preventive measures that can be taken. It also highlights areas within the text that are of particular importance.



**INFORMATION**

This gives advice on applications and provides information on special features.

## 1.4 **Third-party manufacturer licence information**

This product includes Open Source software with various licenses.

Further information is available in the document "Third-party manufacturer licence information PNOZ m ES 14DO" (document number 1006352) at [www.pilz.com](http://www.pilz.com).

## 2 Overview

### 2.1 Scope of supply

- ▶ Expansion module PNOZ m ES 14DO
- ▶ Jumper

### 2.2 Unit features

Application of the product PNOZ m ES 14DO:

Expansion module for connection to a base unit from the PNOZmulti 2 system.

The product has the following features:

- ▶ Can be configured in the PNOZmulti Configurator
- ▶ 14 semiconductor outputs for standard applications
- ▶ LED display for:
  - Error messages
  - Diagnostics
  - Supply voltage
  - Output circuits
- ▶ Plug-in connection terminals:

Either spring-loaded terminal or screw terminal available as an accessory (see [Order references for accessories](#) [ 18]).
- ▶ Please refer to the document "PNOZmulti System Expansion" for details of the base units PNOZmulti 2 that can be connected.

## 2.3 Front view

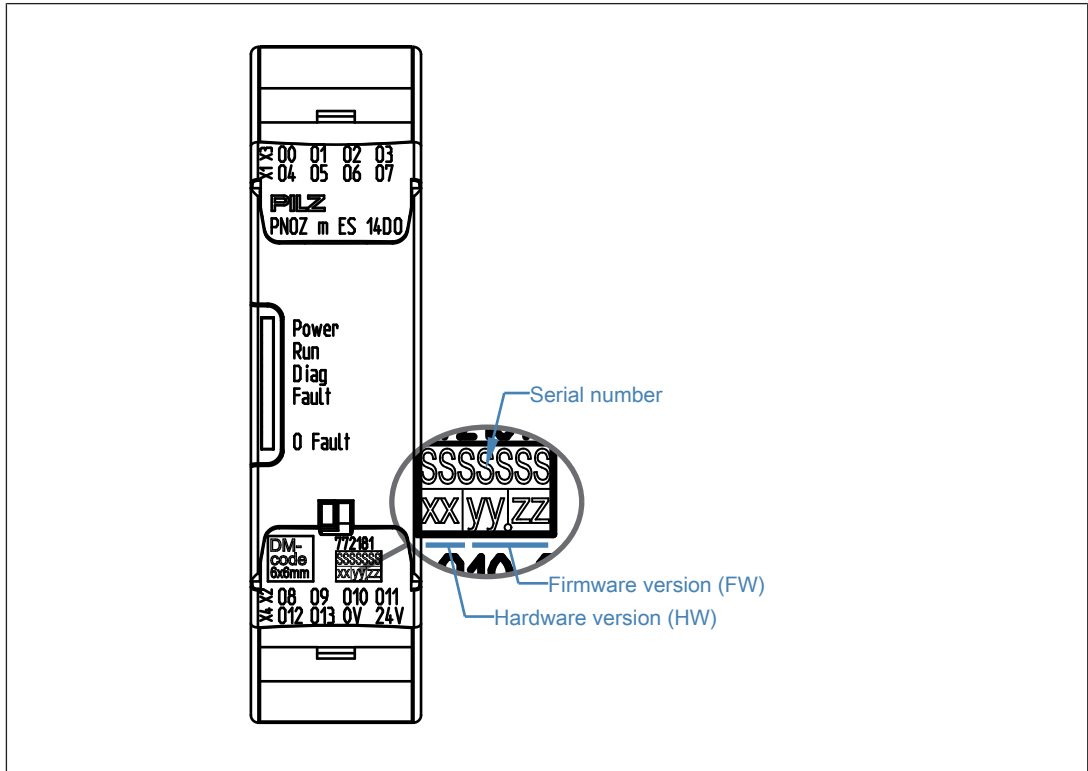

Legend:

- ▶ 0 V, 24 V: Supply connections
- ▶ Outputs O0 – O13
- ▶ LEDs:
  - POWER
  - Run
  - Diag
  - Fault
  - O Fault

## 3 Safety

### 3.1 Intended use

The expansion module may only be connected to a base unit from the configurable system PNOZmulti 2 (please refer to the document "PNOZmulti System Expansion" for details of the base units that can be connected).

The configurable system PNOZmulti 2 is used for the safety-related interruption of safety circuits and is designed for use in:

- ▶ Emergency stop equipment
- ▶ Safety circuits in accordance with VDE 0113 Part 1 and EN 60204-1

The module PNOZ m ES 14DO can be used as a non-safety-related component in accordance with the Lifts Directive 2014/33/EU.

It meets the environmental requirements for passenger and goods lifts in accordance with EN 81-1/2, EN 81-20, EN 81-22 and EN 81-50, as well as the requirements for escalators and moving walks in accordance with EN 115-1.

The safety controller should be installed in a protected environment that meets at least the requirements of pollution degree 2.

Example: Protected inside space or control cabinet with protection type IP54 and appropriate air conditioning.

#### Improper use

The following is deemed improper use in particular

- ▶ Any component, technical or electrical modification to the product,
- ▶ Use of the product outside the areas described in this operating manual,
- ▶ Use of the product outside the technical details (see [Technical details](#) [ 15]).



#### NOTICE

##### EMC-compliant electrical installation

The product is designed for use in an industrial environment. The product may cause interference if installed in other environments. If installed in other environments, measures should be taken to comply with the applicable standards and directives for the respective installation site with regard to interference.

### 3.2 System requirements

Please refer to the "Product Modifications PNOZmulti" document in the "Version overview" section for details of which versions of the base unit and PNOZmulti Configurator can be used for this product.



## **3.3 Safety regulations**

### **3.3.1 Use of qualified personnel**

The products may only be assembled, installed, programmed, commissioned, operated, maintained and decommissioned by competent persons.

A competent person is someone who, because of their training, experience and current professional activity, has the specialist knowledge required to test, assess and operate the work equipment, devices, systems, plant and machinery in accordance with the general standards and guidelines for safety technology.

It is the company's responsibility only to employ personnel who

- ▶ Are familiar with the basic regulations concerning health and safety / accident prevention,
- ▶ Have read and understood the information provided in this description under "Safety",
- ▶ And have a good knowledge of the generic and specialist standards applicable to the specific application.

### **3.3.2 Warranty and liability**

All claims to warranty and liability will be rendered invalid if

- ▶ The product was used contrary to the purpose for which it is intended,
- ▶ Damage can be attributed to not having followed the guidelines in the manual,
- ▶ Operating personnel are not suitably qualified,
- ▶ Any type of modification has been made (e.g. exchanging components on the PCB boards, soldering work etc.).

### **3.3.3 Disposal**

- ▶ When decommissioning, please comply with local regulations regarding the disposal of electronic devices (e.g. Electrical and Electronic Equipment Act).

### **3.3.4 For your safety**

The unit meets all the necessary conditions for safe operation. However, you should always ensure that the following safety requirements are met:

- ▶ This operating manual only describes the basic functions of the unit. The expanded functions are described in the PNOZmulti Configurator's online help. Only use these functions once you have read and understood the documentations.
- ▶ Do not open the housing or make any unauthorised modifications.
- ▶ Please make sure you shut down the supply voltage when performing maintenance work (e.g. exchanging contactors).

## 4 Function description

### 4.1 Functions

The expansion module provides additional semiconductor outputs for standard applications.

The function of the outputs depends on the user program created using the PNOZmulti Configurator. The online help on the PNOZmulti Configurator contains descriptions of the operating modes and all the functions of the PNOZmulti system, plus connection examples.

To be able to switch higher loads, you can switch several outputs in parallel.

There are two groups:

Any of the outputs O0 to O7 can be connected in parallel, and any of the outputs O8 to O13 can be connected in parallel.

### 4.2 System reaction time

Calculation of the maximum reaction time between an input switching off and a linked output in the system switching off is described in the document "PNOZmulti System Expansion".

### 4.3 Block diagram

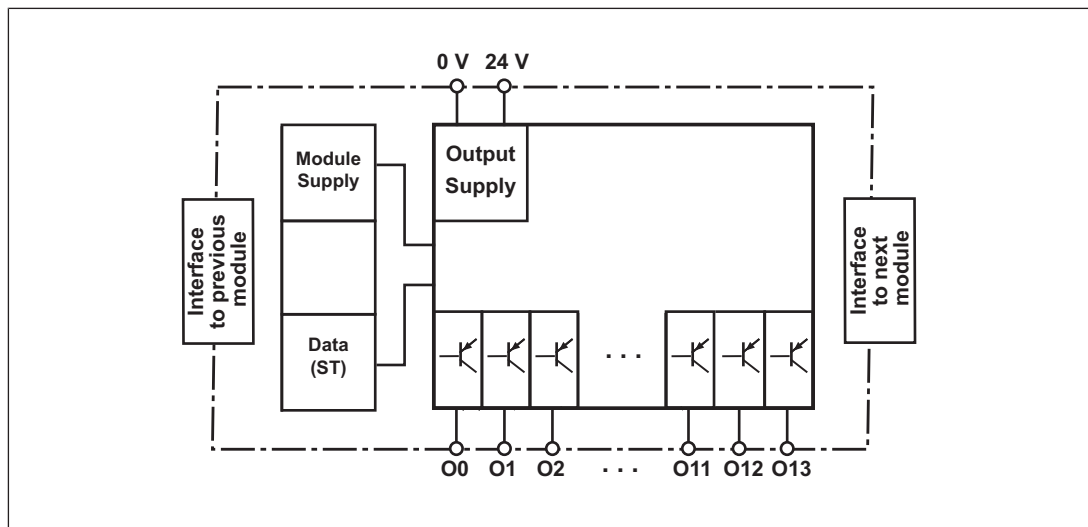

## 5 Installation

### 5.1 General installation guidelines

- ▶ The unit should be installed in a control cabinet with a protection type of at least IP54.
- ▶ Fit the safety system to a horizontal mounting rail. The venting slots must face upward and downward. Other mounting positions could damage the safety system.
- ▶ Use the locking elements on the rear of the unit to attach it to a mounting rail.
- ▶ In environments exposed to heavy vibration, the unit should be secured using a fixing element (e.g. retaining bracket or end angle).
- ▶ Open the locking slide before lifting the unit from the mounting rail.
- ▶ To comply with EMC requirements, the mounting rail must have a low impedance connection to the control cabinet housing.
- ▶ The ambient temperature of the PNOZmulti units in the control cabinet must not exceed the figure stated in the technical details. Air conditioning may otherwise be required.



#### NOTICE

Damage due to electrostatic discharge!

Electrostatic discharge can damage components. Ensure against discharge before touching the product, e.g. by touching an earthed, conductive surface or by wearing an earthed armband.

### 5.2 Dimensions in mm

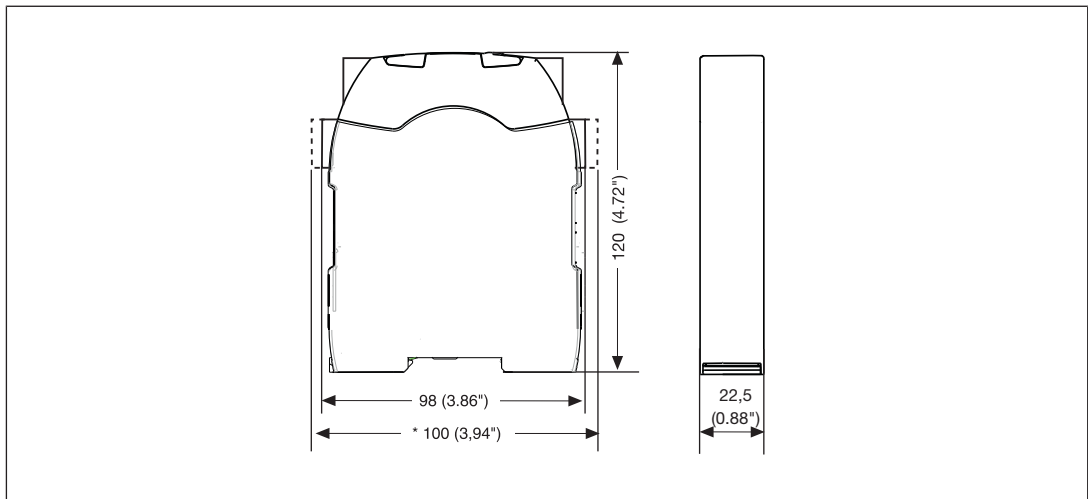

## 5.3 Connecting the base unit and expansion modules

Connect the base unit and the expansion modules as described in the operating manuals for the base modules.

- ▶ The terminator must be fitted to the last expansion module
- ▶ Install the expansion module in the position configured in the PNOZmulti Configurator.

The position of the expansion modules is defined in the PNOZmulti Configurator. The expansion modules are connected to the left or right of the base unit, depending on the type.

Please refer to the document "PNOZmulti System Expansion" for details of the number of modules that can be connected to the base unit and the module types.

The module for standard applications has to be placed to the right of the safe expansion modules.

## 6 Commissioning

### 6.1 General wiring guidelines

The wiring is defined in the circuit diagram of the PNOZmulti Configurator.

Please note:

- ▶ Information given in the [Technical details \[15\]](#) must be followed.
- ▶ The position of the expansion module is specified in the Hardware configuration of the PNOZmulti Configurator.
- ▶ Use copper wiring with a temperature stability of 75 °C.
- ▶ The supply voltage of the semiconductor outputs and the supply voltage of the system are galvanically isolated from each other.
- ▶ Protect the supply voltage as follows:
  - Circuit breaker, characteristic C - 10 A
  - or
  - Blow-out fuse, slow, 10 A

### 6.2 Connection

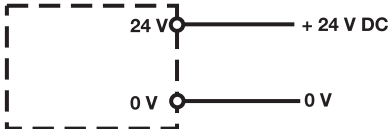
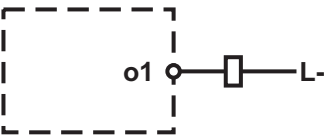
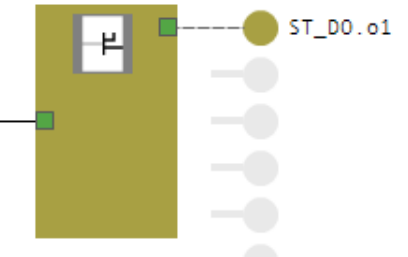
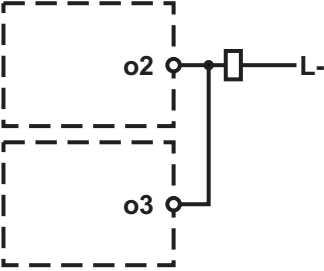
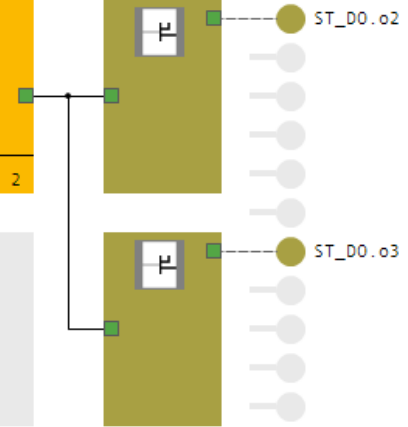

Supply voltage	DC 	
Connection example Single output		
Two outputs parallel		

















## 7 Operation

The PNOZmulti system is ready for operation when the "POWER" and "RUN" LEDs on the base unit are lit continuously.

### 7.1 Messages

#### Legend

-  LED on
-  LED flashes
-  LED off

Fault					
POWER	Run	Diag	Fault	OFault	
					No supply voltage
					Supply voltage for the semiconductor outputs is not present
					Expansion module PNOZ m ES 14DO running without error.
					Expansion module PNOZ m ES 14DO is in a STOP condition.
					Internal error on the expansion module PNOZ m ES 14DO or on the overall system.
					External error on the expansion module PNOZ m ES 14DO or on the overall system.
					Internal error on the outputs of the expansion module PNOZ m ES 14DO. The module will switch to a STOP condition.
					Error on the outputs of the expansion module PNOZ m ES 14DO., e.g. short circuit. The module will switch to a STOP condition.

## 8 Technical details

<b>General</b>	
Certifications	<b>CE, UKCA, UL Listed</b>
Application range	<b>Standard</b>
Module's device code	<b>00F8h</b>
<b>Electrical data</b>	
Supply voltage	
for	<b>Supply to the SC outputs</b>
Voltage	<b>24 V</b>
Kind	<b>DC</b>
Voltage tolerance	<b>-20 %/+25 %</b>
Max. continuous current that the external power supply must provide	<b>8,5 A</b>
Potential isolation	<b>yes</b>
Supply voltage	
for	<b>Module supply</b>
internal	<b>Via base unit</b>
Voltage	<b>24 V</b>
Kind	<b>DC</b>
Current consumption	<b>20 mA</b>
Power consumption	<b>0,5 W</b>
Max. power dissipation of module	<b>2,5 W</b>
Status indicator	<b>LED</b>
Permitted loads	<b>inductive, capacitive, resistive</b>
<b>Semiconductor outputs</b>	
Number of positive-switching single-pole semiconductor outputs	<b>14</b>
Switching capability	
Voltage	<b>24 V</b>
Typ. output current at "1" signal and rated voltage of semiconductor output	<b>0,5 A</b>
Permitted current range	<b>0,000 - 0,600 A</b>
Residual current at "0" signal	<b>0,5 mA</b>
Max. transient pulsed current	<b>1,4 A</b>
Max. internal voltage drop	<b>500 mV</b>
Switch-off delay	<b>1 ms</b>
Potential isolation	<b>yes</b>
Short circuit-proof	<b>yes</b>
Utilisation category in accordance with UL	
Voltage	<b>24 V DC P. D.</b>
Current	<b>0,5 A</b>

### Environmental data

Ambient temperature		
In accordance with the standard		<b>EN 60068-2-14</b>
Temperature range		<b>0 - 60 °C</b>
Forced convection in control cabinet off		<b>55 °C</b>
Storage temperature		
In accordance with the standard		<b>EN 60068-2-1/-2</b>
Temperature range		<b>-25 - 70 °C</b>
Climatic suitability		
In accordance with the standard		<b>EN 60068-2-30, EN 60068-2-78</b>
Condensation during operation		
		<b>Not permitted</b>
Max. operating height above sea level		
		<b>2000 m</b>
EMC		
		<b>EN 61131-2</b>
Vibration		
In accordance with the standard		<b>EN 60068-2-6</b>
Frequency		<b>5 - 150 Hz</b>
Amplitude		<b>0,35 mm</b>
Acceleration		<b>1g</b>
Shock stress		
In accordance with the standard		<b>EN 60068-2-27</b>
Acceleration		<b>15g</b>
Duration		<b>11 ms</b>
Airgap creepage		
In accordance with the standard		<b>EN 61131-2</b>
Overvoltage category		<b>II</b>
Pollution degree		<b>2</b>
Rated insulation voltage		
		<b>30 V</b>
Protection type		
In accordance with the standard		<b>EN 60529</b>
Housing		<b>IP20</b>
Terminals		<b>IP20</b>
Mounting area (e.g. control cabinet)		<b>IP54</b>

### Potential isolation

Potential isolation between		<b>SC output and system voltage</b>
Type of potential isolation		<b>Basic insulation</b>
Rated surge voltage		<b>2500 V</b>

### Mechanical data

Mounting position		
		<b>horizontally on mounting rail</b>
DIN rail		
Top hat rail		<b>35 x 7,5 EN 50022</b>
Recess width		<b>27 mm</b>
Material		
Bottom		<b>PC</b>
Front		<b>PC</b>
Top		<b>PC</b>



<b>Mechanical data</b>	
Connection type	<b>Spring-loaded terminal, screw terminal</b>
Mounting type	<b>plug-in</b>
Conductor cross section with screw terminals	
1 core flexible	<b>0,25 - 2,5 mm<sup>2</sup>, 24 - 12 AWG</b>
2 core with the same cross section, flexible without crimp connectors or with TWIN crimp connectors	<b>0,2 - 1,5 mm<sup>2</sup>, 24 - 16 AWG</b>
Torque setting with screw terminals	<b>0,5 Nm</b>
Conductor cross section with spring-loaded terminals:	
Flexible with/without crimp connector	<b>0,2 - 2,5 mm<sup>2</sup>, 24 - 12 AWG</b>
Spring-loaded terminals: Terminal points per connection	<b>2</b>
Stripping length with spring-loaded terminals	<b>9 mm</b>
Dimensions	
Height	<b>101,4 mm</b>
Width	<b>22,5 mm</b>
Depth	<b>120 mm</b>
Weight	<b>100 g</b>

Where standards are undated, the 2016-05 latest editions shall apply.

## 9 Order reference

### 9.1 Product

Product type	Features	Order no.
PNOZ m ES 14DO	Configurable safe small controllers PNOZmulti 2, expansion module, 14 semiconductor outputs for standard applications.	772181

### 9.2 Accessories

#### 9.2.1 Replacement terminals

Product type	Features	Order no.
PNOZ s Setscrew terminals 22.5mm	Set of plug-in replacement terminals 4-pin of screw type, PU = 1 piece each X1, X2, X3, X4.	750004
PNOZ s Setspring-loaded terminals 22.5mm	Set of plug-in replacement terminals 4-pin of spring-loaded type, PU = 1 piece each X1, X2, X3, X4.	751004

#### 9.2.2 Connector plug

Product type	Features	Order no.
PNOZ mm0.xp connector left (10 pcs)	Connector plug to connect the modules to the left-hand side of the PNOZmulti base unit, yellow/black (10 pieces).	779260

# ► Support

Technical support is available from Pilz round the clock.

## Americas

### Brazil

+55 11 97569-2804

### Canada

+1 888 315 7459

### Mexico

+52 55 5572 1300

### USA (toll-free)

+1 877-PILZUSA (745-9872)

## Asia

### China

+86 21 60880878-216

### Japan

+81 45 471-2281

### South Korea

+82 31 778 3300

## Australia and Oceania

### Australia

+61 3 95600621

### New Zealand

+64 9 6345350

## Europe

### Austria

+43 1 7986263-0

### Belgium, Luxembourg

+32 9 3217570

### France

+33 3 88104003

### Germany

+49 711 3409-444

### Ireland

+353 21 4804983

### Italy, Malta

+39 0362 1826711

## Scandinavia

+45 74436332

## Spain

+34 938497433

## Switzerland

+41 62 88979-32

## The Netherlands

+31 347 320477

## Turkey

+90 216 5775552

## United Kingdom

+44 1536 462203

## You can reach our international hotline on:

+49 711 3409-222

support@pilz.com

Pilz develops environmentally-friendly products using ecological materials and energy-saving technologies. Offices and production facilities are ecologically designed, environmentally-aware and energy-saving. So Pilz offers sustainability, plus the security of using energy-efficient products and environmentally-friendly solutions.



We are represented internationally. Please refer to our homepage [www.pilz.com](http://www.pilz.com) for further details or contact our headquarters.

Headquarters: Pilz GmbH & Co. KG, Felix-Wankel-Straße 2, 73760 Ostfildern, Germany  
Telephone: +49 711 3409-0, Telefax: +49 711 3409-133, E-Mail: [info@pilz.com](mailto:info@pilz.com), Internet: [www.pilz.com](http://www.pilz.com)

**PILZ**  
THE SPIRIT OF SAFETY

1004299-EN-05, 2022-10 Printed in Germany  
© Pilz GmbH & Co. KG, 2019

CECE®, CHRE®, CMSE®, InduraNET p®, Leansafe®, Master of Safety®, Master of Security®, PAS4000®, PAScall®, PASconfig®, Pilz®, PTT®, PLID®, PMCPirimo®, PMCPiritego®, PMCTendo®, PMD®, PMJ®, PNOZ®, PRCM®, PRM®, PRMNET p®, PSEN®, PSENi®, PSS®, PVS®, SafetyBUS p®, SafetyEYE®, THE SPIRIT OF SAFETY® are registered and protected trademarks of Pilz GmbH & Co. KG in some countries. We would point out that product features may vary from the details stated in this document, depending on the status at the time of publication and the scope of the equipment. We accept no responsibility for the validity, accuracy and entirety of the text and graphics presented in this information. Please contact our Technical Support if you have any questions.