



Visualisation; Diagnostics

Easy to Configure

Programming IEC 61131-3

Rapid Installation

PDP67 F 4 code

PILZ

THE SPIRIT OF SAFETY

- ▶ Decentralised periphery

This document is the original document.

Where unavoidable, for reasons of readability, the masculine form has been selected when formulating this document. We do assure you that all persons are regarded without discrimination and on an equal basis.

All rights to this documentation are reserved by Pilz GmbH & Co. KG. Copies may be made for the user's internal purposes. Suggestions and comments for improving this documentation will be gratefully received.

Pilz®, PIT®, PMI®, PNOZ®, Primo®, PSEN®, PSS®, PVIS®, SafetyBUS p®, SafetyEYE®, SafetyNET p®, the spirit of safety® are registered and protected trademarks of Pilz GmbH & Co. KG in some countries.



SD means Secure Digital

1	Introduction	5
1.1	Validity of documentation	5
1.1.1	Retaining the documentation	5
1.2	Using the documentation	5
1.3	Definition of symbols	5
2	Overview	7
2.1	Unit structure	7
2.1.1	Range	7
2.1.2	Unit features	7
2.2	Front view	8
3	Safety	9
3.1	Intended use	9
3.2	Safety regulations	9
3.2.1	Use of qualified personnel	9
3.2.2	Warranty and liability	10
3.2.3	Disposal	10
4	Function description	11
4.1	Operation	11
4.1.1	Internal wiring diagram	11
4.1.2	Diagnostics	11
5	Installation	12
5.1	General installation guidelines	12
5.1.1	Dimensions	12
6	Wiring	13
6.1	General wiring guidelines	13
6.2	Assignment of female connectors	13
7	Preparing for operation	15
7.1	Connection	15
7.1.1	Independent circuit	15
7.1.1.1	Examples of independent circuit	16
7.1.2	Series connection of modules	17
7.1.2.1	Examples of series connection	18
7.1.2.2	Voltage drop	19
8	Operation	21
8.1	Messages	21
8.1.1	Display elements for device diagnostics	21
9	Technical details	22
10	Order reference	24
10.1	Order reference for module	24

10.2 Order reference for accessories.....24

1 Introduction

1.1 Validity of documentation

This documentation is valid for the products PDP67 F 4 code, PDP67 F 4 code VA. It is valid until new documentation is published.

This operating manual explains the function and operation, describes the installation and provides guidelines on how to connect the product.

1.1.1 Retaining the documentation

This documentation is intended for instruction and should be retained for future reference.

1.2 Using the documentation

This document is intended for instruction. Only install and commission the product if you have read and understood this document. The document should be retained for future reference.

1.3 Definition of symbols

Information that is particularly important is identified as follows:



DANGER!

This warning must be heeded! It warns of a hazardous situation that poses an immediate threat of serious injury and death and indicates preventive measures that can be taken.



WARNING!

This warning must be heeded! It warns of a hazardous situation that could lead to serious injury and death and indicates preventive measures that can be taken.



CAUTION!

This refers to a hazard that can lead to a less serious or minor injury plus material damage, and also provides information on preventive measures that can be taken.



NOTICE

This describes a situation in which the product or devices could be damaged and also provides information on preventive measures that can be taken. It also highlights areas within the text that are of particular importance.



INFORMATION

This gives advice on applications and provides information on special features.

2 Overview

2.1 Unit structure

2.1.1 Range

- ▶ Module PDP67 F 4 code/PDP67 F 4 code VA
- ▶ 1 Adapter PDP67 Connector cs/PDP67 Connector cs VA for connecting the supply voltage for the module and sensors
- ▶ 5 labels
- ▶ 4 blind plugs for sealing unused female connectors

2.1.2 Unit features

Application of the products PDP67 F 4 code, PDP67 F 4 code VA:

Decentralised passive distributor for use in rugged industrial environments up to protection type IP67 for connecting PSENcode, PSENSlock and PSENIini sensors to a Pilz control system.

The product has the following features:

- ▶ Protection type IP67
- ▶ M12 female connectors
- ▶ A maximum of 4 sensors can be connected to each module
- ▶ Female connectors for series connection
- ▶ LED indicator for:
 - Supply voltage
 - Status of sensors

2.2 Front view

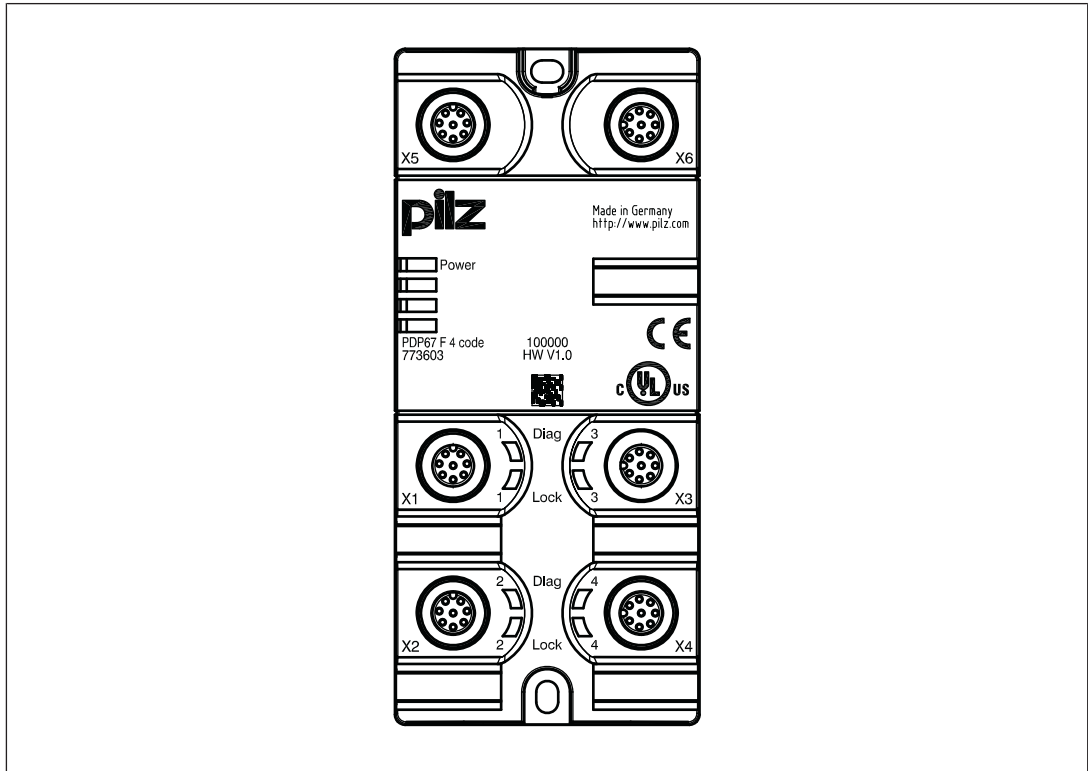

Key:

- ▶ X1 ... X4:
Female connectors for connecting the sensors
- ▶ X5:
Female connectors for connecting to the evaluation device (for connecting the sensors to X1 ... X4)
- ▶ X6:
Female connectors for connecting signal outputs (Diag) and inputs for control commands for magnetic guard locking (Lock)
- ▶ LEDs:
 - Power
 - Diag
 - Lock

3 Safety

3.1 Intended use

Decentralised passive distributor for use in rugged industrial environments up to protection type IP67 for connecting PSENcode, PSENslock and PSENini sensors to a Pilz control system.

Improper use

The following is deemed improper use in particular

- ▶ Any component, technical or electrical modification to the product,
- ▶ Use of the product outside the areas described in this operating manual,
- ▶ Use of the product outside the technical details (see Technical details).



NOTICE

EMC-compliant electrical installation

The product is designed for use in an industrial environment. The product may cause interference if installed in other environments. If installed in other environments, measures should be taken to comply with the applicable standards and directives for the respective installation site with regard to interference.

3.2 Safety regulations

3.2.1 Use of qualified personnel

The products may only be assembled, installed, programmed, commissioned, operated, maintained and decommissioned by persons who are competent to do so.

A competent person is a qualified and knowledgeable person who, because of their training, experience and current professional activity, has the specialist knowledge required. To be able to inspect, assess and operate devices, systems and machines, the person has to be informed of the state of the art and the applicable national, European and international laws, directives and standards.

It is the company's responsibility only to employ personnel who

- ▶ Are familiar with the basic regulations concerning health and safety / accident prevention,
- ▶ Have read and understood the information provided in the section entitled Safety
- ▶ Have a good knowledge of the generic and specialist standards applicable to the specific application.

3.2.2 Warranty and liability

All claims to warranty and liability will be rendered invalid if

- ▶ The product was used contrary to the purpose for which it is intended,
- ▶ Damage can be attributed to not having followed the guidelines in the manual,
- ▶ Operating personnel are not suitably qualified,
- ▶ Any type of modification has been made (e.g. exchanging components on the PCB boards, soldering work etc.).

3.2.3 Disposal

- ▶ When decommissioning, please comply with local regulations regarding the disposal of electronic devices (e.g. Electrical and Electronic Equipment Act).

4 Function description

4.1 Operation

Using the module PDP67 F 4 code/PDP67 F 4 code **VA**, up to four PSENcode, PSENslock and/or PSENini sensors can be connected in series and connected to an evaluation device.

4.1.1 Internal wiring diagram

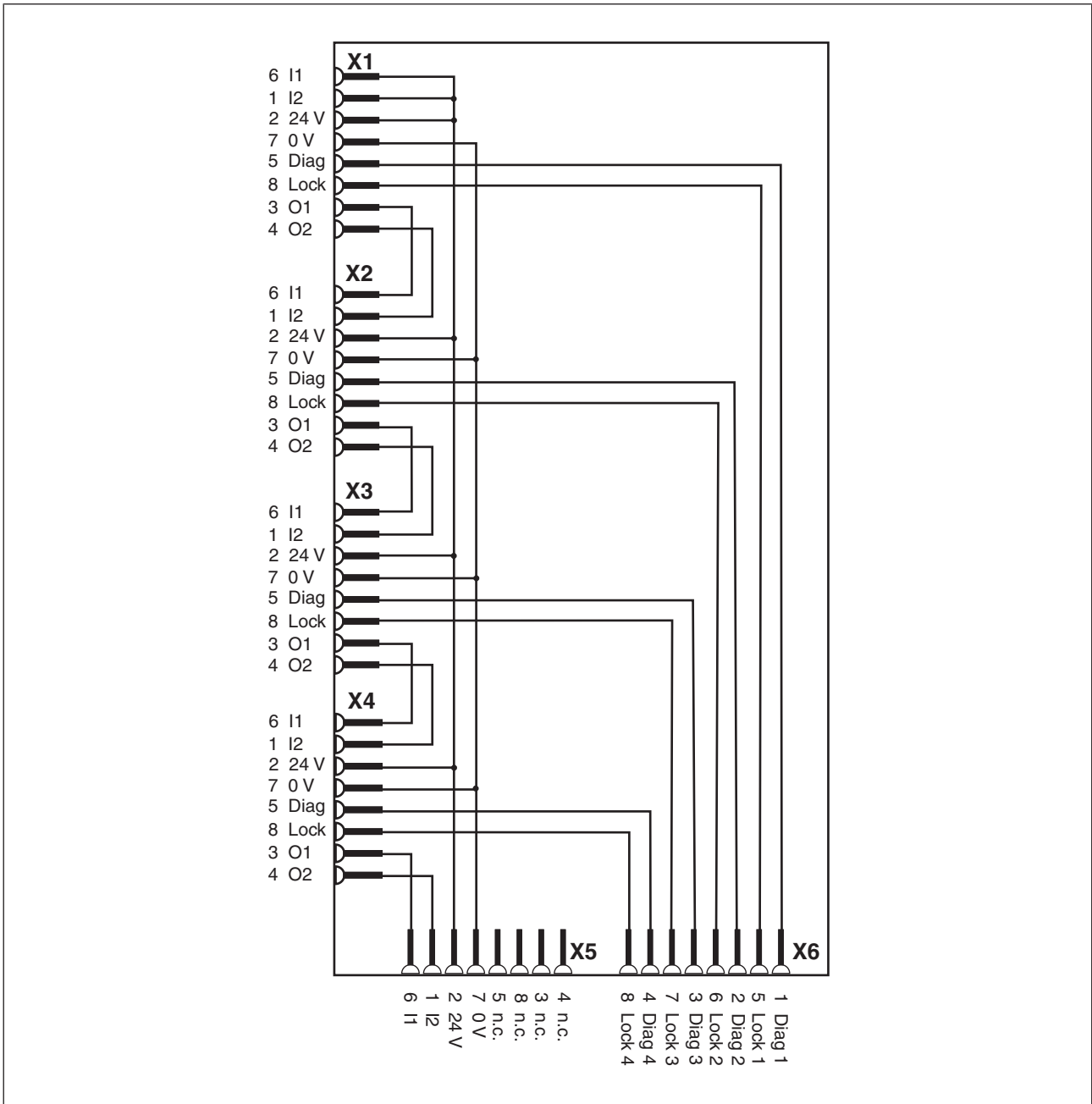

4.1.2 Diagnostics

The LEDs indicate the statuses of the signal outputs (Diag) and the inputs for control commands for magnetic guard locking (Lock).

5 Installation

5.1 General installation guidelines

The product must be fastened to a flat mounting surface, so that there is no strain on the housing when the module is screwed down. The mounting distances will depend on which plug-in connectors are used and on the bending radius of the cables. Unused connectors should be sealed using blind plugs.

To install the system, proceed as follows:

- ▶ Fit 2 x M4 internal threads on the mounting surface.
- ▶ Use two fixing screws to attach the product to the mounting plate.

5.1.1 Dimensions

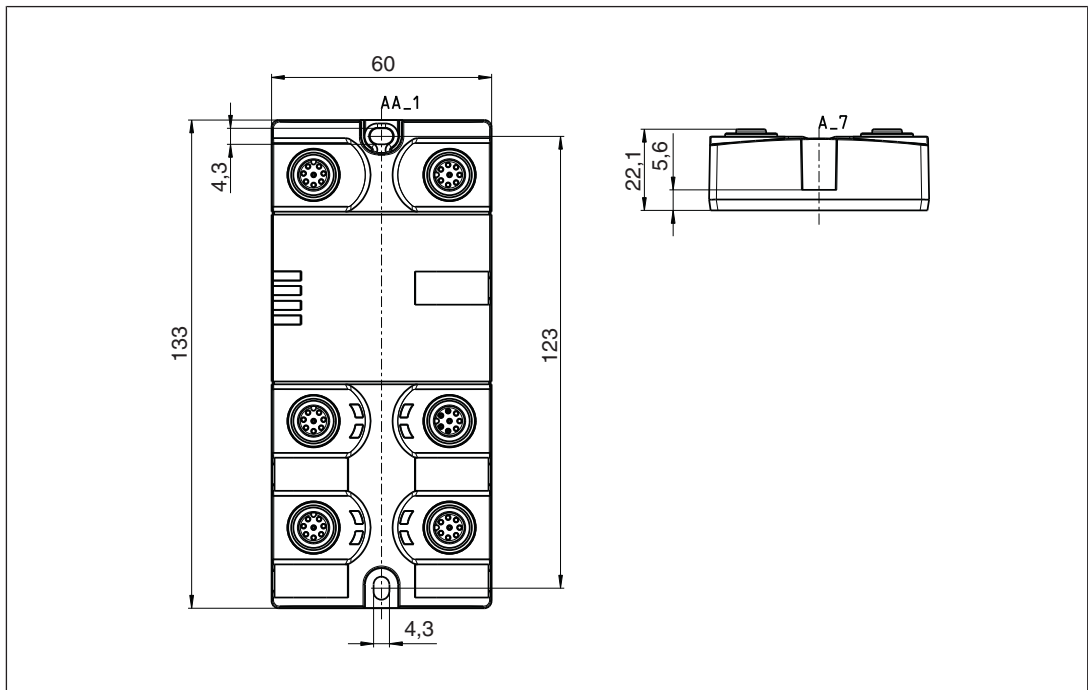

6 Wiring

6.1 General wiring guidelines

Please note:

- ▶ Information given in the “Technical details” must be followed.
- ▶ Where safety-related applications are concerned, it is essential that short circuits and open circuits are unable to cause a hazardous condition within a plant. The way in which this is done will depend on the degree of hazard from the plant, the switching frequency of the sensors and the level of safety of the sensors and actuators.
- ▶ You can use prefabricated sensor cables from Pilz for connecting the sensors.



CAUTION!

In order to guarantee protection type IP67, unused plug-in connectors should be sealed using the blind plugs supplied.

6.2 Assignment of female connectors

Inputs/outputs X1 to X4	Assignment	
8-pin M12 female connectors for connecting the sensors	1: input I2 (S21) 2: 24 VDC (A1) 3: Output O1 (12) 4: Output O2 (22) 5: Signal output Diag (Y32) 6. Input I1 (S11) 7. 0 V (A2) 8. Input lock for control command for magnetic guard locking (S31)	

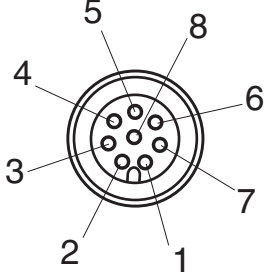
Inputs/outputs X5	Assignment	
<p>8-pin M12 female connector for connecting to the safety inputs of an evaluation device</p>	<p>1: Input I2 2: 24 VDC (U_B) 3: n.c. 4: n.c. 5: n.c. 6: Input I1 7: 0 V (U_B) 8: n.c.</p>	

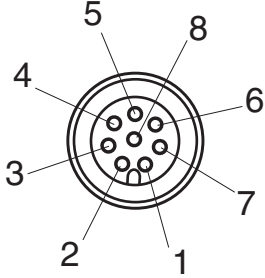
Inputs/outputs X6	Assignment	
<p>8-pin M12 female connector for connecting to the standard inputs and outputs of an evaluation device</p>	<p>1: Signal output Diag 1 2: Signal output Diag 2 3: Signal output Diag 3 4: Signal output Diag 4 5: Input lock 1 (for control command for magnetic guard locking) 6: Input lock 2 (for control command for magnetic guard locking) 7: Input lock 3 (for control command for magnetic guard locking) 8: Input lock 4 (for control command for magnetic guard locking)</p>	

7 Preparing for operation

7.1 Connection

Please note:

- ▶ A maximum of 4 sensors per module can be connected to female connectors X1 ... X4. Note the current load capacity of the modules (see current load capacity for UB)
- ▶ The evaluation device is always connected to the last non-assigned female connector X2 ... X5.
- ▶ The adapter **PDP67 Connector cs/PDP67 Connector cs VA** must be used for connecting the evaluation device and for connecting the modules in series. The adapter requires the use of a female connector for connecting the supply voltage. This prevents the risk of a short circuit from contact with the contacts of a male connector.
- ▶ The signal outputs (Diag) of the connected sensors are connected to pins 1 to 4 of the X6 female connector.
- ▶ The control commands for magnetic guard locking ("Lock_Unlock") for PSENSlock are connected to pins 5 to 8 of the X6 female connector.
- ▶ The sensors must always be connected to the module in consecutive order.

Example:

- Correct: Sensor to female connector X1, X2, X3
- Wrong: Sensor to female connector X1, X2, X4



NOTICE

Connecting the sensors in series increases the delay-on de-energisation. Please refer to the guidelines contained in the operating manuals for the sensors.

7.1.1 Independent circuit



WARNING!

Loss of safety function due to incorrect connection sequence!

If the evaluation device is connected to a female connector before or between the sensors, all sensors connected thereafter will not be evaluated. Serious injury or death may result, depending on the application.

Always connect the evaluation device to the last free female connector.



NOTICE

When commissioning, activate the safety function of each sensor in the safety chain and check the correct response of the evaluation device's safety outputs.

7.1.1.1 Examples of independent circuit

Connection example 1: Connection of four sensors (X1 ... X4)

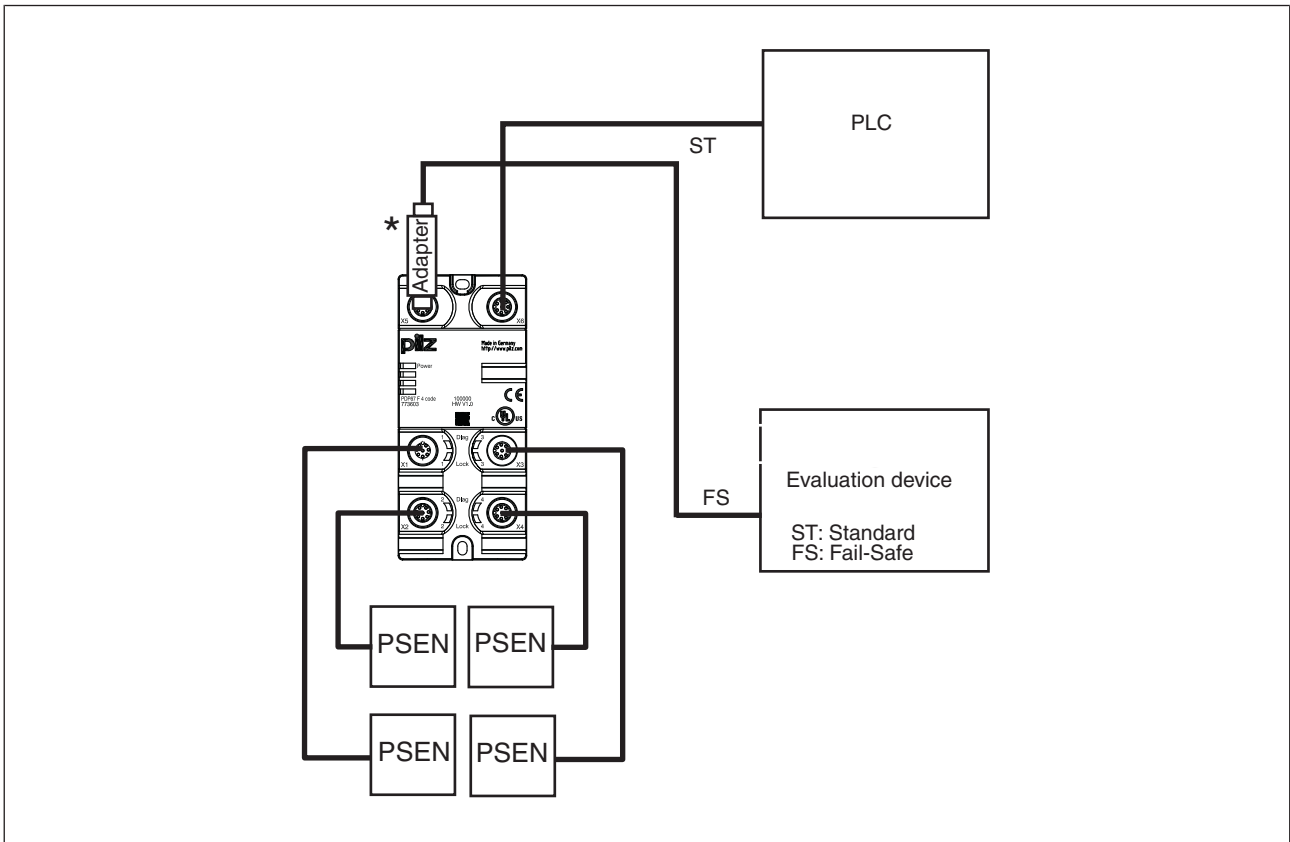

*Adapter: **PDP67 Connector cs/PDP67 Connector cs VA**

Connection example 2: Connection of three sensors (X1 ... X3)

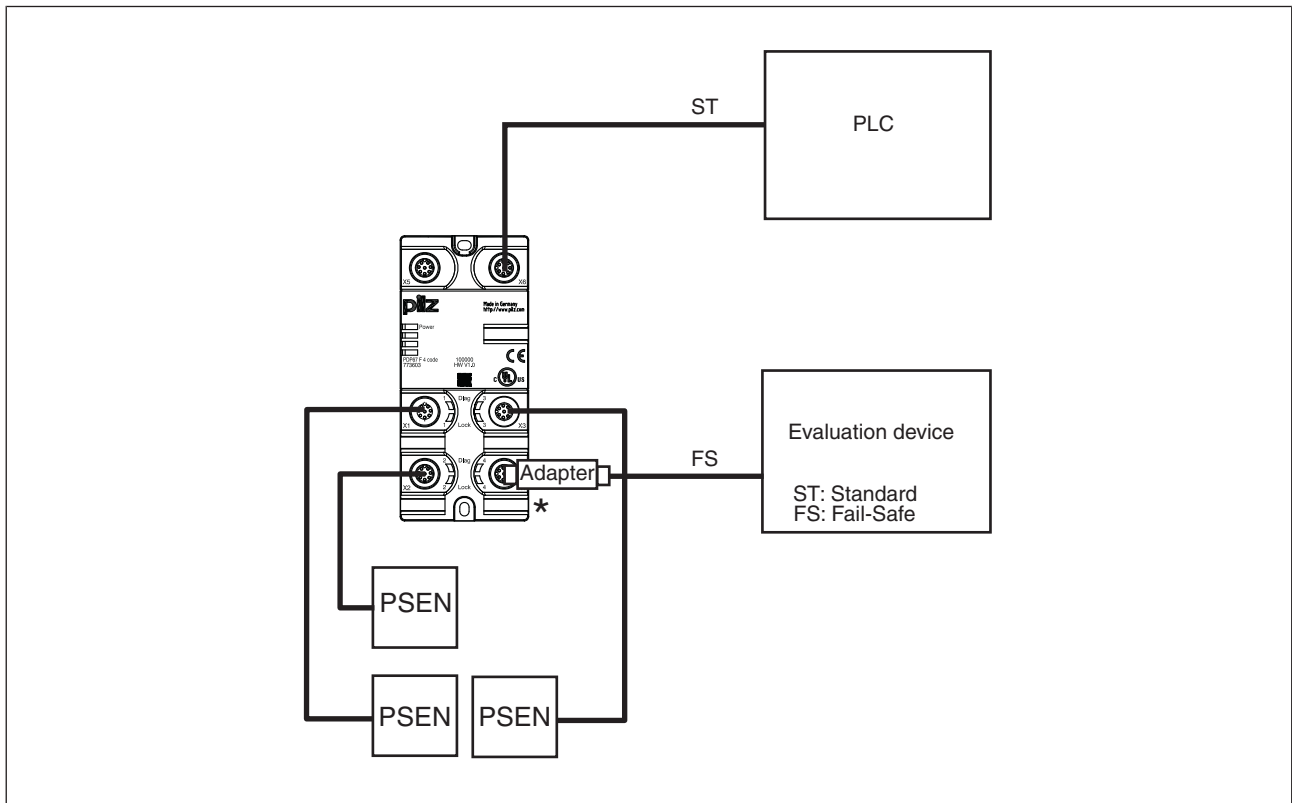

*Adapter: **PDP67 Connector cs/PDP67 Connector cs VA**

7.1.2 Series connection of modules

Please note:

- ▶ The series connection of the modules is always created with the last free female connector X2 ... X5 and the X1 female connector of the next module. The adapter **PDP67 Connector cs/PDP67 Connector cs VA** must be used for connecting the modules in series.
- ▶ The voltage at the last module must not fall below the permitted supply voltage level. Please refer to the operating manual for the sensors used for the permissible values for the supply voltage (see "Voltage tolerance" in the chapter entitled "Technical details"). An example of how the voltage drop is calculated can be found in the chapter entitled "Voltage drop".



WARNING!

Loss of safety function due to incorrect connection sequence!

If the evaluation device is connected to a female connector before or between the sensors, all sensors connected thereafter will not be evaluated. Serious injury or death may result, depending on the application.

Always connect the evaluation device to the last free female connector.



NOTICE

When commissioning, activate the safety function of each sensor in the safety chain and check the correct response of the evaluation device's safety outputs.

7.1.2.1 Examples of series connection

Connection example 1: Series connection when connecting four sensors (X1 ... X4) on the first module

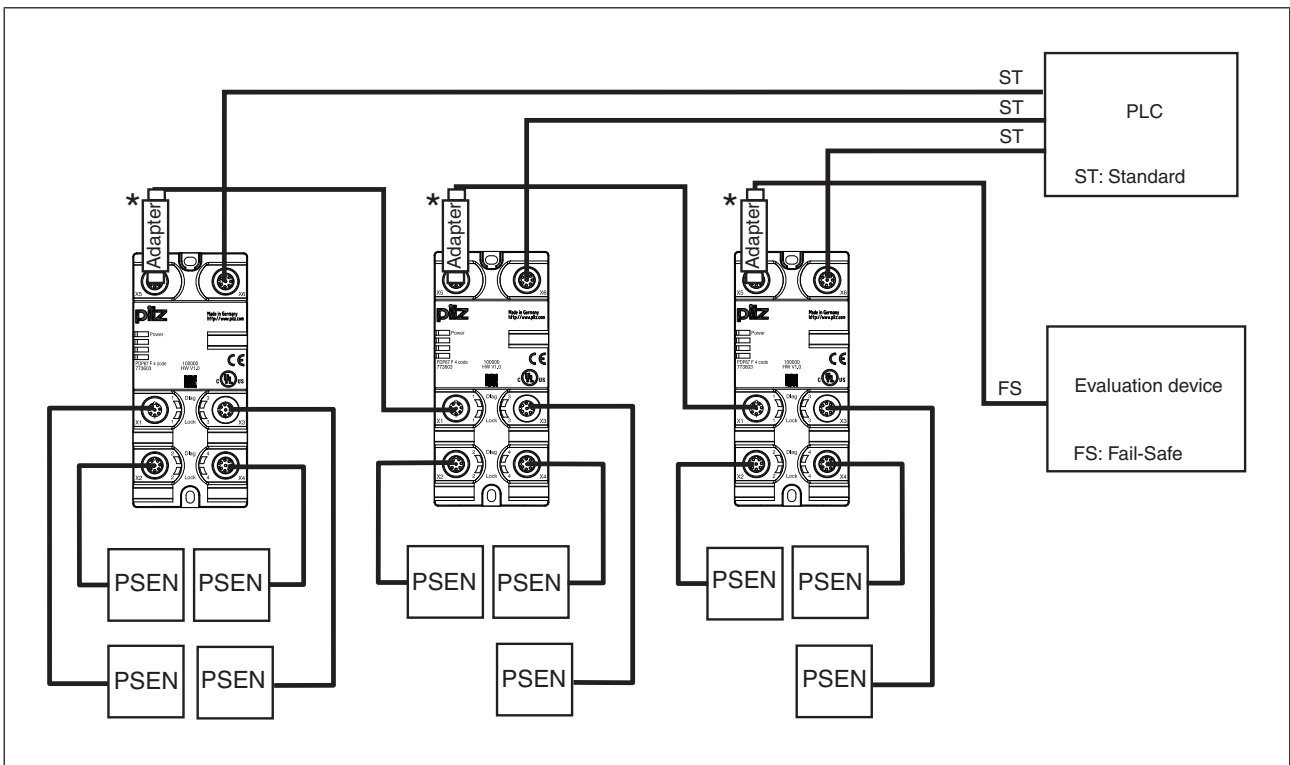

*Adapter: **PDP67 Connector cs/PDP67 Connector cs VA**

Connection example 2: Series connection when connecting three sensors (X1 ... X3) on the first module

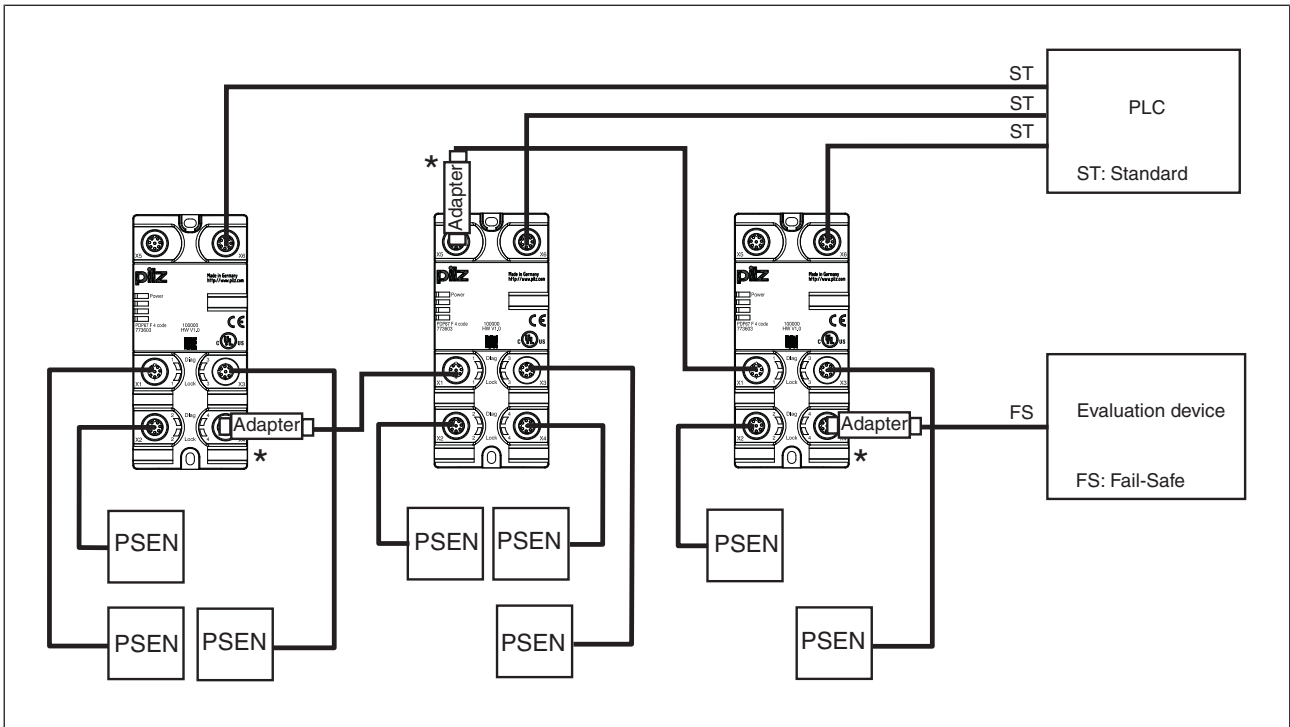

*Adapter: **PDP67 Connector cs/PDP67 Connector cs VA**

7.1.2.2 Voltage drop

The max. cable length depends on the voltage drop in the supply voltage cables. The level of voltage drop is determined by the:

- ▶ Cable resistance on the supply voltage cables
- ▶ Operating current of the modules
- ▶ Load on the modules

To increase the max. cable length, the input voltage can be permanently increased by the voltage tolerance (see Technical Details).

Calculation example:

- ▶ The 0.25 mm² sensor cable is used.
Voltage drop per 10 m and per 100 mA: 0.15 V

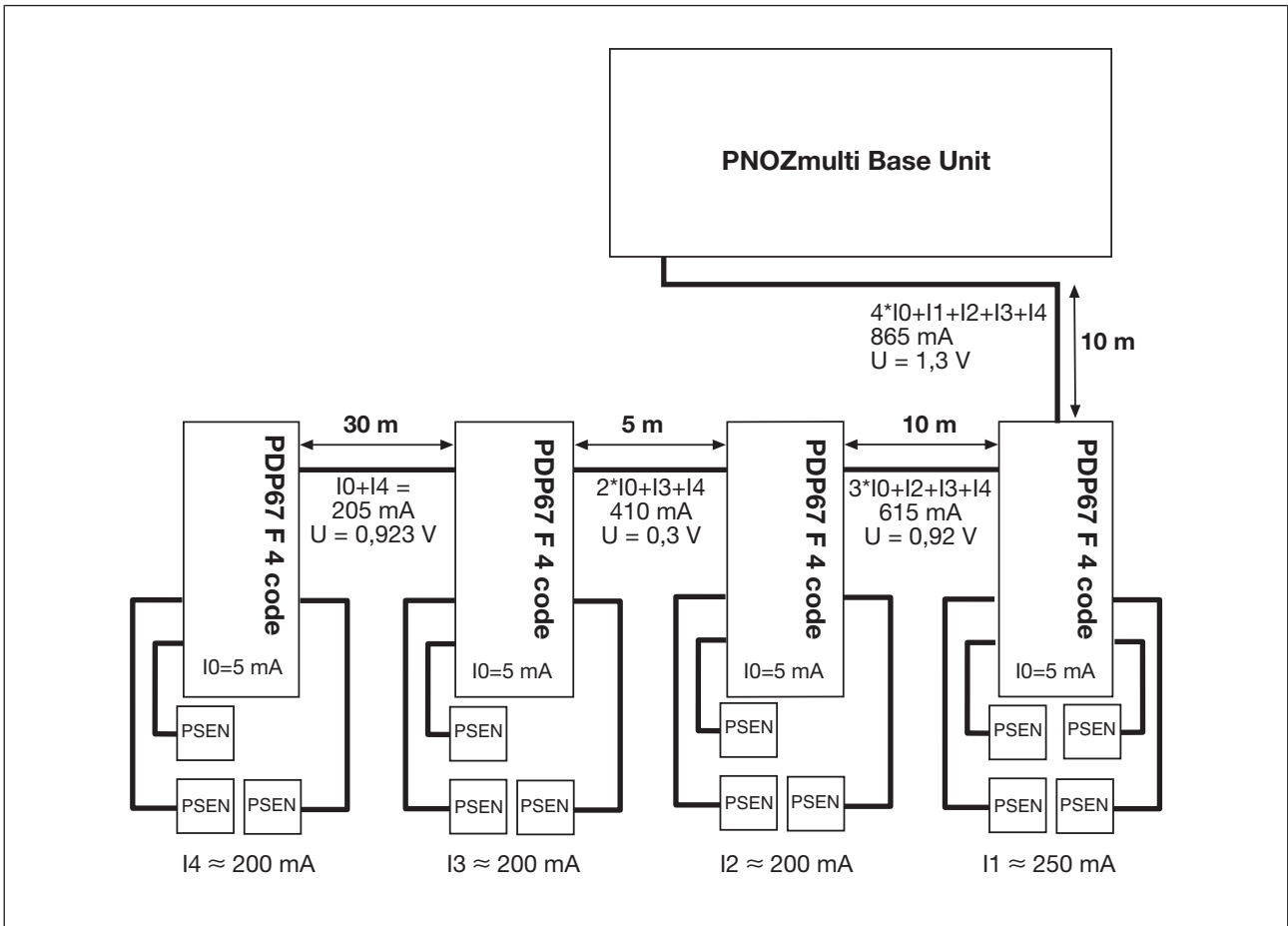

Guidelines for various cable types

Cable type	Voltage drop per 10 m and per 100 mA
PSS SB BUSCABLE LC	0.1 V
Sensor cable 0.25 mm ²	0.15 V
Sensor cable 0.34 mm ²	0.11 V
Sensor cable 0.5 mm ²	0.07 V



8 Operation







8.1 Messages

The module is ready for operation when the "Power" LED is lit continuously.

8.1.1 Display elements for device diagnostics

Legend

-  LED on
-  LED flashes
-  LED off

LED	LED status		Meaning
Power		green	The unit is ready for operation
			The unit is not ready for operation
Diag		green	The actuator is within the response range
			The actuator is not within the response range
Lock		green	Control command for magnetic guard locking available
			Control command for magnetic guard locking not available

9 Technical details

General		
	773603	773613
Certifications	CE, KOSHA, UKCA, cULus Listed	CE, KOSHA, UKCA, cULus Listed
Electrical data		
	773603	773613
Supply voltage		
Voltage	24 V	24 V
Kind	DC	DC
Current load capacity at UB	2 A	2 A
Environmental data		
	773603	773613
Climatic suitability	EN 60068-2-1, EN 60068-2-14, EN 60068-2-2	EN 60068-2-1, EN 60068-2-14, EN 60068-2-2
Ambient temperature		
In accordance with the standard	EN 60068-2-14	EN 60068-2-14
Temperature range	-40 - 60 °C	-40 - 60 °C
Storage temperature		
In accordance with the standard	EN 60068-2-1/-2	EN 60068-2-1/-2
Temperature range	-40 - 70 °C	-40 - 70 °C
Climatic suitability		
In accordance with the standard	EN 60068-2-78	EN 60068-2-78
Humidity	93 % r. h. at 40 °C	93 % r. h. at 40 °C
Condensation during operation	Short-term	Short-term
Vibration		
In accordance with the standard	EN 60068-2-6	EN 60068-2-6
Frequency	10 - 55 Hz	10 - 55 Hz
Amplitude	0,35 mm	0,35 mm
Shock stress		
In accordance with the standard	EN 60068-2-27	EN 60068-2-27
Number of shocks	3	3
Duration	11 ms	11 ms
In accordance with the standard	EN 60068-2-27	EN 60068-2-27
Number of shocks	500	500
Duration	16 ms	16 ms
Airgap creepage		
In accordance with the standard	EN 60664-1	EN 60664-1
Overvoltage category	II	II
Pollution degree	2	2
Protection type		
Housing	IP67	IP67
Terminals	IP67	IP67
Mechanical data		
	773603	773613
Material		
Top	PBT	PBT
Connection type	M12	Stainless steel 1.4305

Mechanical data	773603	773613
Mounting type	screw interlocked	screw interlocked
Dimensions		
Height	120 mm	120 mm
Width	60 mm	60 mm
Depth	20 mm	20 mm
Weight	240 g	240 g

10 Order reference

10.1 Order reference for module

Type	Features	Order no.
PDP67 F 4 code	Decentralised passive junction	773603
PDP67 F 4 code VA	Decentralised passive junction, V2A ring nut	773613

10.2 Order reference for accessories

Type	Features	Order no.
PDP67 Connector cs	Adapter	773610
PDP67 Connector cs VA	Adapter, V4A union screw	773612
PSEN cable M12-8sf M12-8sm	2 m	540340
PSEN cable M12-8sf M12-8sm	5 m	540341
PSEN cable M12-8sf M12-8sm	10 m	540342
PSEN cable M12-8sf M12-8sm	20 m	540343
PSEN cable M12-8sf M12-8sm	30 m	540344

Support

Technical support is available from Pilz round the clock.

Americas

Brazil

+55 11 97569-2804

Canada

+1 888 315 7459

Mexico

+52 55 5572 1300

USA (toll-free)

+1 877-PILZUSA (745-9872)

Asia

China

+86 21 60880878-216

Japan

+81 45 471-2281

South Korea

+82 31 778 3300

Australia and Oceania

Australia

+61 3 95600621

New Zealand

+64 9 6345350

Europe

Austria

+43 1 7986263-0

Belgium, Luxembourg

+32 9 3217570

France

+33 3 88104003

Germany

+49 711 3409-444

Ireland

+353 21 4804983

Italy, Malta

+39 0362 1826711

Scandinavia

+45 74436332

Spain

+34 938497433

Switzerland

+41 62 88979-32

The Netherlands

+31 347 320477

Turkey

+90 216 5775552

United Kingdom

+44 1536 462203

You can reach our international hotline on:

+49 711 3409-222

support@pilz.com

Pilz develops environmentally-friendly products using ecological materials and energy-saving technologies. Offices and production facilities are ecologically designed, environmentally-aware and energy-saving. So Pilz offers sustainability, plus the security of using energy-efficient products and environmentally-friendly solutions.



We are represented internationally. Please refer to our homepage www.pilz.com for further details or contact our headquarters.

Headquarters: Pilz GmbH & Co. KG, Felix-Wankel-Straße 2, 73760 Ostfildern, Germany
Telephone: +49 711 3409-0, Telefax: +49 711 3409-133, E-Mail: info@pilz.com, Internet: www.pilz.com

PILZ
THE SPIRIT OF SAFETY

CECE®, CHRE®, CMSE®, InduraNET p®, Leansafe®, Master of Safety®, Master of Security®, PAS4000®, PAScall®, PASconfig®, Pilz®, PTT®, PLID®, PMCprimo®, PMCprotego®, PMClendo®, PMD®, PMJ®, PNOZ®, PRBM®, PRCM®, PRIMO®, PRM®, PSEN®, PSS®, PVIS®, SafetyBUS p®, SafetyEYE®, THE SPIRIT OF SAFETY® are registered and protected trademarks of Pilz GmbH & Co. KG in some countries. We would point out that product features may vary from the details stated in this document, depending on the status at the time of publication and the scope of the equipment. We accept no responsibility for the validity, accuracy and entirety of the text and graphics presented in this information. Please contact our Technical Support if you have any questions.

1001531-EN-07, 2022-11 Printed in Germany
© Pilz GmbH & Co. KG, 2019