



Visualisation; Diagnostics

Easy to Configure

Programming IEC 61131-3

Rapid Installation

## PIT es Set10u-5c PCB

**PILZ**  
THE SPIRIT OF SAFETY

► Control and signal devices

This document is the original document.

All rights to this documentation are reserved by Pilz GmbH & Co. KG. Copies may be made for the user's internal purposes. Suggestions and comments for improving this documentation will be gratefully received.

Source code from third-party manufacturers or open source software has been used for some components. The relevant licence information is available on the Internet on the Pilz homepage.

Pilz®, PIT®, PMI®, PNOZ®, Primo®, PSEN®, PSS®, PVIS®, SafetyBUS p®, SafetyEYE®, SafetyNET p®, the spirit of safety® are registered and protected trademarks of Pilz GmbH & Co. KG in some countries.



SD means Secure Digital

<b>Introduction</b> .....	<b>5</b>
Validity of documentation .....	5
Using the documentation .....	5
Definition of symbols .....	5
<b>Overview</b> .....	<b>6</b>
Unit features .....	6
Scope of supply .....	7
Marking on E-STOP pushbutton .....	8
<b>Safety</b> .....	<b>9</b>
Intended use .....	9
Safety regulations .....	10
Safety assessment .....	10
Use of qualified personnel .....	10
Warranty and liability .....	11
Disposal .....	11
For your safety .....	11
<b>Block diagram/terminal configuration</b> .....	<b>12</b>
<b>Function description</b> .....	<b>12</b>
Operating states .....	12
<b>Installation</b> .....	<b>13</b>
<b>Wiring</b> .....	<b>16</b>
<b>Preparing for operation</b> .....	<b>16</b>
<b>Requirements and connection to evaluation devices</b> .....	<b>18</b>
Wiring table .....	21
Examples for connection to Pilz evaluation devices .....	22
<b>Faults/interference</b> .....	<b>22</b>
<b>Care and maintenance</b> .....	<b>23</b>
<b>Dimensions in mm</b> .....	<b>23</b>
<b>Technical details</b> .....	<b>24</b>
Safety characteristic data .....	25
<b>Supplementary data</b> .....	<b>26</b>
Permitted operating height .....	26
<b>Order reference</b> .....	<b>27</b>
Product .....	27

Accessories .....	27
<b>EC declaration of conformity .....</b>	<b>27</b>

## Introduction

### Validity of documentation

This documentation is valid for the product PIT es Set10u-5c PCB. It is valid until new documentation is published.

This operating manual explains the function and operation, describes the installation and provides guidelines on how to connect the product.

### Using the documentation

This document is intended for instruction. Only install and commission the product if you have read and understood this document. The document should be retained for future reference.

### Definition of symbols

Information that is particularly important is identified as follows:



#### **DANGER!**

This warning must be heeded! It warns of a hazardous situation that poses an immediate threat of serious injury and death and indicates preventive measures that can be taken.



#### **WARNING!**

This warning must be heeded! It warns of a hazardous situation that could lead to serious injury and death and indicates preventive measures that can be taken.



#### **CAUTION!**

This refers to a hazard that can lead to a less serious or minor injury plus material damage, and also provides information on preventive measures that can be taken.



#### **NOTICE**

This describes a situation in which the product or devices could be damaged and also provides information on preventive measures that can be taken. It also highlights areas within the text that are of particular importance.



### **INFORMATION**

This gives advice on applications and provides information on special features.

## **Overview**

### **Unit features**

- ▶ E-STOP device in accordance with EN 60204-1, EN ISO 13849, EN ISO 13850 and EN 60947-5-5, contacts in accordance with EN 60947-5-1
- ▶ Clear visual display when E-STOP function is active
- ▶ In inactive state, the E-STOP pushbutton is not lit and it can no longer be detected as an E-STOP
- ▶ Turn in either direction to release
- ▶ Bevelled protective collar
- ▶ Integral flashing function (configurable) of the yellow bevelled protective collar after operating the E-STOP pushbutton

**Scope of supply**

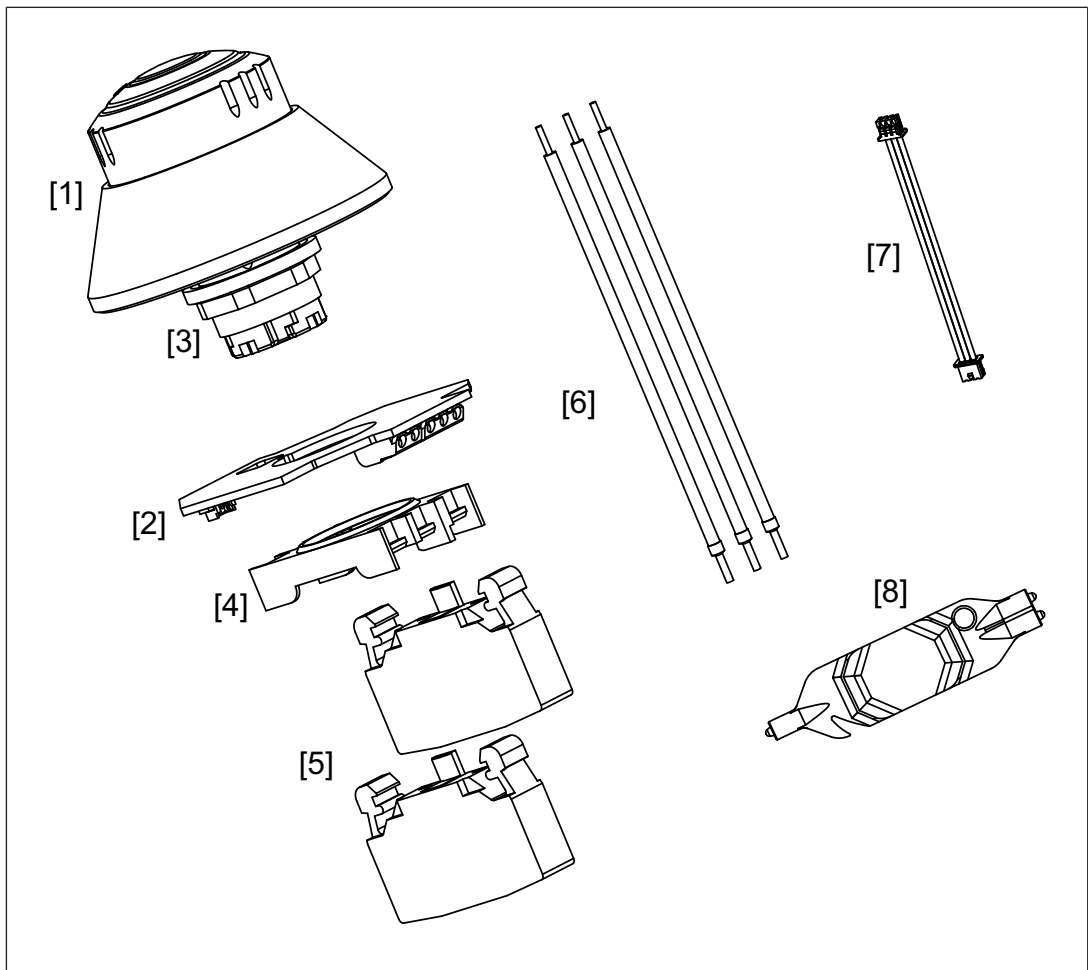

**Legend**

- [1] E-STOP pushbutton (Order No. 400 540)
- [2] LED safety printed circuit board (Order No. 400 342)
- [3] Plastic nut
- [4] Contact block bracket (Order No. 400 331)
- [5] 2 contact blocks (PIT es2c Order No. 400 321)
- [6] 3 cables for connecting the LED safety printed circuit board with the contact blocks (included in Order No. 400 342)
- [7] Three-core connection cable for connecting the LED safety printed circuit board with the E-STOP pushbutton (included in Order No. 400 342)
- [8] Assembly aid for the terminals X1 and X2 on the LED safety printed circuit board

### Marking on E-STOP pushbutton

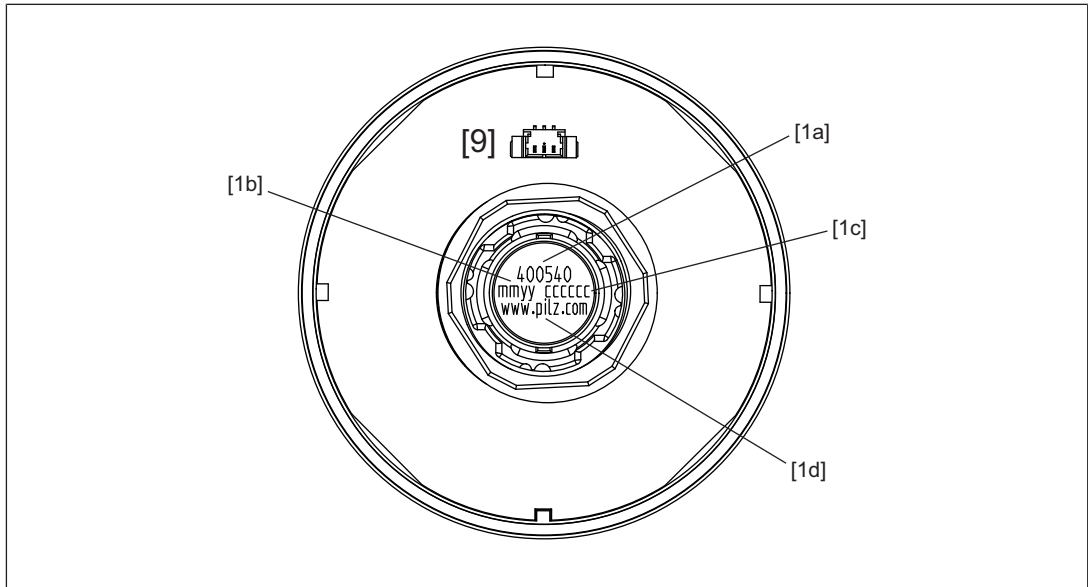

### Legend

- [1a] Order number
- [1b] Date of manufacture mmyy
- [1c] Batch number
- [1d] Address Pilz homepage



## Safety

### Intended use

The E-STOP function is triggered by operating the active E-STOP device and the voltage to the evaluation device is interrupted (dual-channel, fully operated).

In active state, the E-STOP device PIT es Set10u-5c PCB is lit (the actuator lights up red) and it fulfils the requirements in accordance with EN ISO 13850.

In inactive state, the E-STOP pushbutton PIT es Set10u-5c PCB is not lit and it can not be detected as an emergency stop device. The E-STOP function is deactivated.

The safety function of the E-STOP device is:

- ▶ Ensuring that the red lighting can be detected under defined environmental conditions. In case of a lighting failure of the active E-STOP device's lightings, the E-STOP function is triggered and the voltage to the evaluation device is interrupted (single-channel, partially operated).



#### CAUTION!

It must not be possible to defeat the E-STOP pushbuttons. Otherwise material damage and severe injuries may result, depending on the application.

The E-STOP pushbutton must **not** be used in place of other safety measures.



#### WARNING!

##### Loss of the safety function by deactivating the E-STOP device

Deactivating the E-STOP device may result in serious injury and death. The E-STOP function can only be deactivated when the plant/machine is in an operating mode that does not become dangerous to the operator, or when the safety function is implemented by other measures.



#### NOTICE

The E-STOP device must be used only in the inner area and it must be protected from direct sunlight. Its brightness covers the scope of the workplace regulations ASR A3.4 for common industrial environment.



#### NOTICE

The E-STOP device must not be used in an atmosphere with a high degree of hydrogen sulphide (H<sub>2</sub>S), e.g. in sewage plants and farms.



**NOTICE**

Only one PIT es Set10u may be used per circuit (no cascading).

The following is deemed improper use in particular

- ▶ Any component, technical or electrical modification to the product,
- ▶ Use of the product outside the areas described in this manual,
- ▶ Use of the product outside the technical details (see [Technical details](#)  24]).



**NOTICE**

**EMC-compliant electrical installation**

The product is designed for use in an industrial environment. The product may cause interference if installed in other environments. If installed in other environments, measures should be taken to comply with the applicable standards and directives for the respective installation site with regard to interference.

**Safety regulations**

**Safety assessment**

Before using a device it is necessary to perform a safety assessment in accordance with the Machinery Directive.

Functional safety is guaranteed for the product as a single component. However, this does not guarantee the functional safety of the overall plant/machine. In order to achieve the required safety level for the overall plant/machine, define the safety requirements for the plant/machine and then define how these must be implemented from a technical and organisational standpoint.

**Use of qualified personnel**

The products may only be assembled, installed, programmed, commissioned, operated, maintained and decommissioned by competent persons.

A competent person is a qualified and knowledgeable person who, because of their training, experience and current professional activity, has the specialist knowledge required. To be able to inspect, assess and operate devices, systems and machines, the person has to be informed of the state of the art and the applicable national, European and international laws, directives and standards.

It is the company's responsibility only to employ personnel who

- ▶ Are familiar with the basic regulations concerning health and safety / accident prevention,
- ▶ Have read and understood the information provided in the section entitled Safety
- ▶ Have a good knowledge of the generic and specialist standards applicable to the specific application.

### **Warranty and liability**

All claims to warranty and liability will be rendered invalid if

- ▶ The product was used contrary to the purpose for which it is intended,
- ▶ Damage can be attributed to not having followed the guidelines in the manual,
- ▶ Operating personnel are not suitably qualified,
- ▶ Any type of modification has been made (e.g. exchanging components on the PCB boards, soldering work etc.).

### **Disposal**

- ▶ In safety-related applications, please comply with the mission time  $T_M$  in the safety-related characteristic data.
- ▶ When decommissioning, please comply with local regulations regarding the disposal of electronic devices (e.g. Electrical and Electronic Equipment Act).

### **For your safety**

The unit meets all the necessary conditions for safe operation. However, please note the following:

- ▶ Check the function of the pushbutton before commissioning for the first time and then at regular intervals (at least annually).

## Block diagram/terminal configuration

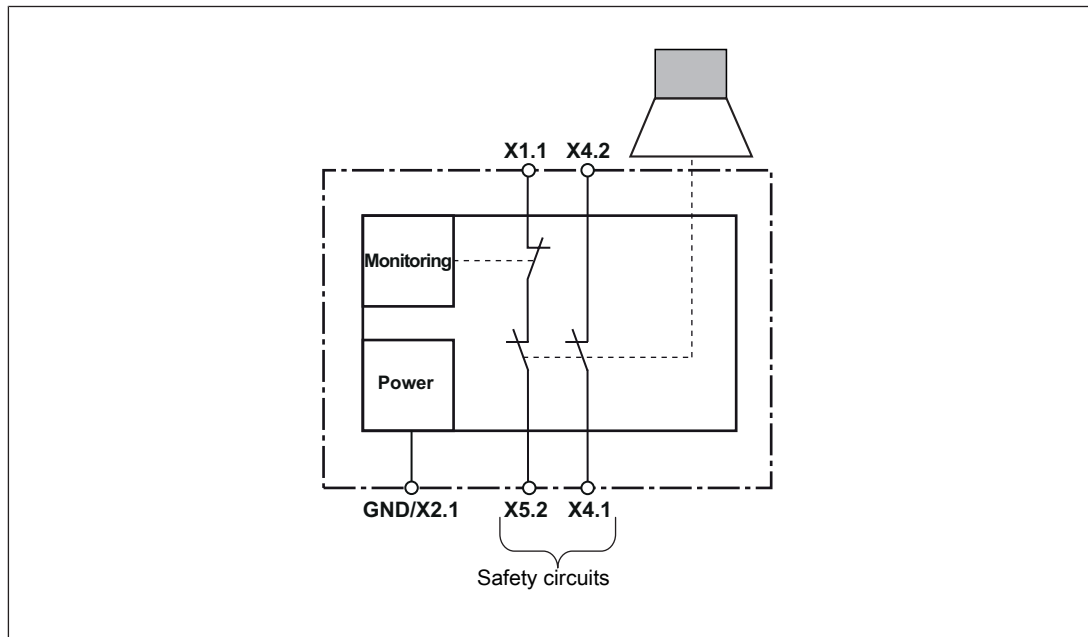

## Function description

The E-STOP device is active when actuator and bevelled protective collar are lit. When the E-STOP device is activated, the two safety circuits X1.1-X5.2 and X4.2-X4.1 will open. The actuator is locked. The bevelled protective collar flashes yellow when the wiring is appropriate (see [Connection example, flashing function is active](#) [ 20]).

The E-STOP function must be reset deliberately by unlocking the actuator (turn to the left or right).

The E-STOP function is inactive when the connections X1.1 and X4.2 are disconnected from the supply. The lighting goes out, the E-STOP device is without function.

The E-STOP device detects whether the red lighting is defective, and it opens the safety circuit X1.1-X5.2.

## Operating states

- ▶ **Active:** The E-STOP device is electrically supplied and it is not operated. The actuator is illuminated red, the bevelled protective collar is illuminated yellow.
- ▶ **Inactive:** The E-STOP device is not electrically supplied and it is therefore not illuminated.
- ▶ **Triggered:** The E-STOP device is in active state, the actuator has been pressed and it is therefore locked. The two safety circuits are opened (fully operated). The actuator is illuminated red, the bevelled protective collar is illuminated yellow. Corresponding to the wiring, the yellow light is lit permanently, or it flashes.

## Installation



### CAUTION!

Always install the device with the supply voltage switched off. Because of electrical safety, the device must be installed only on a mounting plate made from **insulating material**.



### NOTICE

Please note during installation:

- Use a mounting plate with a smooth surface to ensure a tight seal
- When the E-STOP pushbutton has been uninstalled, it has to be exchanged for a new E-STOP pushbutton to ensure a tight seal
- The unit is an installation unit, the LED safety printed circuit board and the contact blocks must be installed in a mounting area  $\geq$  IP54 (the actuation side of the emergency stop button is excluded from this)





### NOTICE

Damage due to electrostatic discharge!

Electrostatic discharge can damage components. Ensure against discharge before touching the product, e.g. by touching an earthed, conductive surface or by wearing an earthed armband.

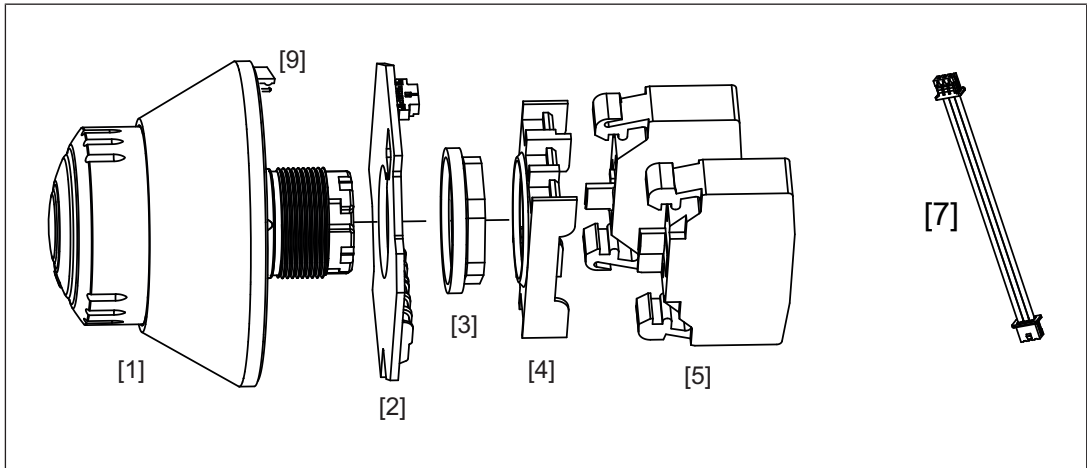
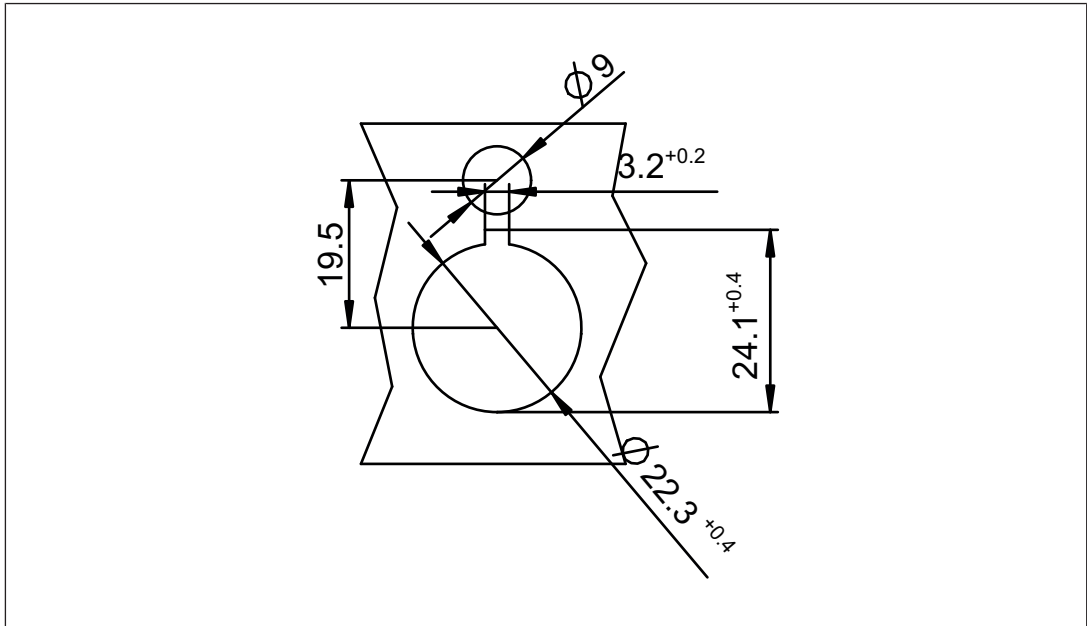
- ▶ Prepare a cutout ( $\varnothing$  22.3 mm) in the mounting plate. Material thickness of the mounting plate: 1 ... 5 mm. The surface of the mounting plate should be smooth.
- ▶ Prepare another opening in the mounting plate ( $\varnothing$  9 mm) for the lighting connection.



- ▶ Remove the plastic nut [3] from the neck of the E-STOP pushbutton [1].
- ▶ Check to ensure that the adhesive seal on the bottom of the E-STOP pushbutton [1] is not damaged.
- ▶ Plug the connector of the three-pole connection cable [7] into the socket [9] on the bottom side of the E-STOP pushbutton [1], the plug-in connection is reverse polarity protected.
- ▶ Insert the E-STOP pushbutton [1] into the opening of the mounting plate. Route the three-core connection cable [7] to the opening for the lighting connection.
- ▶ Plug the LED safety printed circuit board [2] on the neck of the E-STOP pushbutton [1]. Route the three-core connection cable [7] through the rectangular opening on the circuit board.
- ▶ Fix the LED safety printed circuit board [2] with the plastic nut [3]. Note the torque setting of 1.3 ... 2.1 Nm. We recommend that you use the "PIT es wrench" installation wrench for fixing the plastic nut [3] (see [Order data](#) [ 27]).



**NOTICE**

Make sure that the LED safety printed circuit board [2] does not twist when fixing, to prevent damage of the connection cable [7].

Only the plastic nut supplied [3] must be used for fixing the LED safety circuit board [2].

- ▶ Plug the pre-installed contact blocks [5] with the bracket [4] on the neck of the E-STOP pushbutton [1] and secure it by turning it to the right. Check that the locking is correct and audible.

## Wiring

Please note:

- ▶ Information given in the "[Technical details \[24\]](#)" must be followed.
- ▶ The power supply must meet the regulations for PELV in accordance with EN 60204-1.
- ▶ The maximum cable length depends on the conductor cross section used and the current requirement of the connected evaluation device. In a maximum current consumption of 100 mA, plus the current of the input circuits of the evaluation device, a rated operating voltage of 24 V (tolerance: -20 %/+15 %, that is at least 19.2 V) must be available.
- ▶ Only one PIT es Set10u may be used per circuit. However, it may be cascaded with conventional electromechanical E-STOP devices that have only N/C contacts. Note that when operating a conventional E-STOP device which is in the chain before the PIT es Set10u-5c PCB, the PIT es Set10u-5c PCB is not electrically supplied and therefore it is not illuminated.

## Preparing for operation

- ▶ Connect the socket X3 [9] on the LED safety printed circuit board via the three-core connection cable [7] to the socket [10] on the bottom side of the E-STOP pushbutton. The plug-in connection is reverse polarity protected.

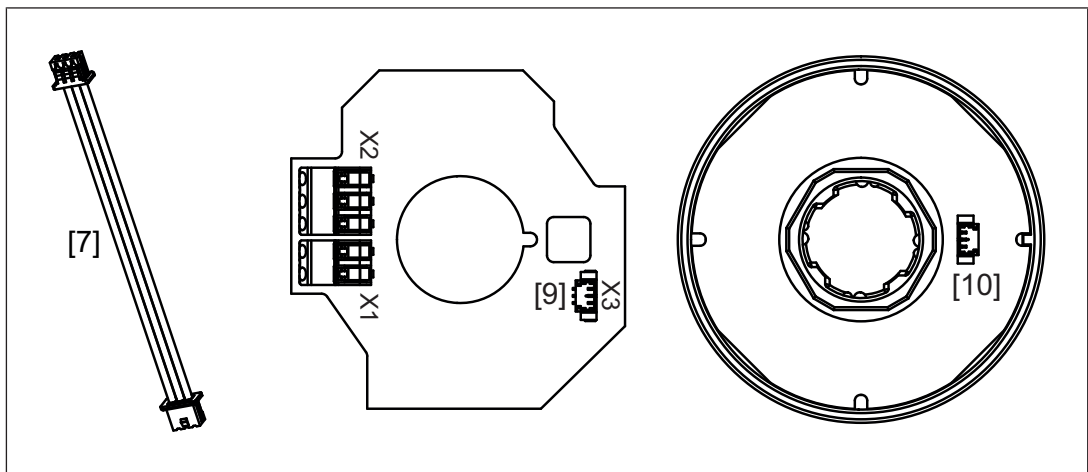

- ▶ Connect the contact blocks with the LED safety printed circuit board as in the drawing below. To do this, use the three cables that are included in the scope of supply [6]. The cables are stripped and equipped with crimp connectors at one side. Plug the stripped side of the cables into the terminals on the LED safety printed circuit board and the crimp connectors into the contact blocks.



### NOTICE

Do **not** equip the cables for connecting the terminals on the LED safety printed circuit board with crimp connectors.

Be sure to use the provided assembly aid [8] to activate the spring-loaded terminals X1 and X2.



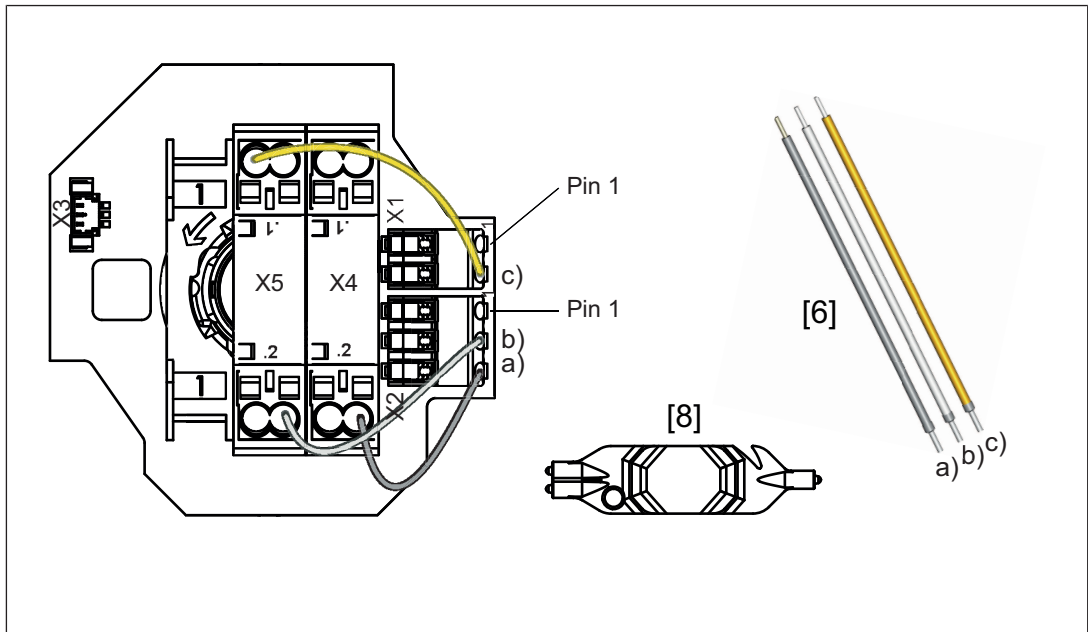

**Legend**

- a) Grey Connection X4.2 with X2.3
- b) White Connection X5.2 with X2.2
- c) Yellow Connection X5.1 with X1.2



**NOTICE**

Check the function of the emergency stop device before commissioning for the first time and then at regular intervals (at least annually).

## Requirements and connection to evaluation devices

For use of PIT es Set10u-5c PCB an evaluation device must be connected.

Connect the PIT es Set10u-5c PCB

- ▶ either with a Pilz evaluation device
- ▶ or with an evaluation device with defined properties (see section [Defined properties of evaluation devices: \[📖 18\]](#))

Suitable Pilz evaluation devices are, for example:

- ▶ PNOZelog for E-STOP monitoring
  - PNOZ e1.1p (Order No. 774 133)
- ▶ PNOZ X for safety gate monitoring
  - PNOZ X2.8P (Order No. 777 301 and 787 301)
- ▶ PNOZsigma for safety gate monitoring
  - PNOZ s5 (Order No. 750 105 and 751 105)
- ▶ PNOZmulti for E-STOP monitoring
  - PNOZ m B0 (Order No. 772 100)
- ▶ PSSuniversal
  - PSSu E F 4DI (Order No. 312 200)
- ▶ Decentralised periphery
  - PDP67 F 8DI ION (Order No. 773 600)

### Defined properties of evaluation devices:

- ▶ Dual-channel with detection of partial operation (only one channel of the input circuit is open)
- ▶ Detection of shorts across contacts and earth fault detection: Detection of shorts across contacts is possible also via a positive and negative input circuit
- ▶ Digital inputs type 2 in accordance with IEC 61131-2
- ▶ Offset test pulses (not overlapping) with a maximum duration of the on/off test pulse of 7.5 ms

Connect the evaluation device as described in the evaluation device's operating manual.

Please note:

- ▶ Protective separation of the outputs to voltages over 60 V
- ▶ The power supply that feeds the evaluation device must meet the regulations for PELV in accordance with EN 60204-1.
- ▶ The evaluation device must meet the requirements in the [Technical details \[📖 24\]](#). The specified values must not be exceeded.
- ▶ On the LED safety printed circuit board there are two permanently installed blow-out fuses. If the fuses are tripped by overcurrent or overvoltage, the LED safety printed circuit board must be exchanged.

Ensure the wiring and EMC requirements of IEC 60204-1 are met.

Use cables with the following features to connect the evaluation device to the E-STOP device:

- ▶ Connection to the LED safety circuit board, terminals X1 and X2:
  - Connection cross-section: 0.25 ... 0.75 mm<sup>2</sup>, stripping length: 7 ... 9 mm
- ▶ Connection to the contact blocks, terminals X4 and X5:
  - Connection cross-section: 0.25 ... 1.0 mm<sup>2</sup>, with crimp connectors in accordance with DIN 46228 section 4 (with plastic sleeve, length of the copper sleeve 10 ... 12 mm)



**WARNING!**

**In case of faulty wiring, there is a loss of the safety function "Ensuring that the red lighting can be detected under defined environmental conditions"!**

If terminal X1.1 is transposed with X1.2 when connecting the LED safety printed circuit board, the opening one of the contacts in case of an error (partial operation) and therefore the safety function "Ensuring that the red lighting can be detected under defined environmental conditions" is no longer guaranteed.

Check the function of the E-STOP pushbutton before commissioning by interrupting the GND connection of the LED safety circuit board (see also [Check wiring](#) [22]). The evaluation device must switch off then. When an evaluation device does not switch off, there is a wiring error.

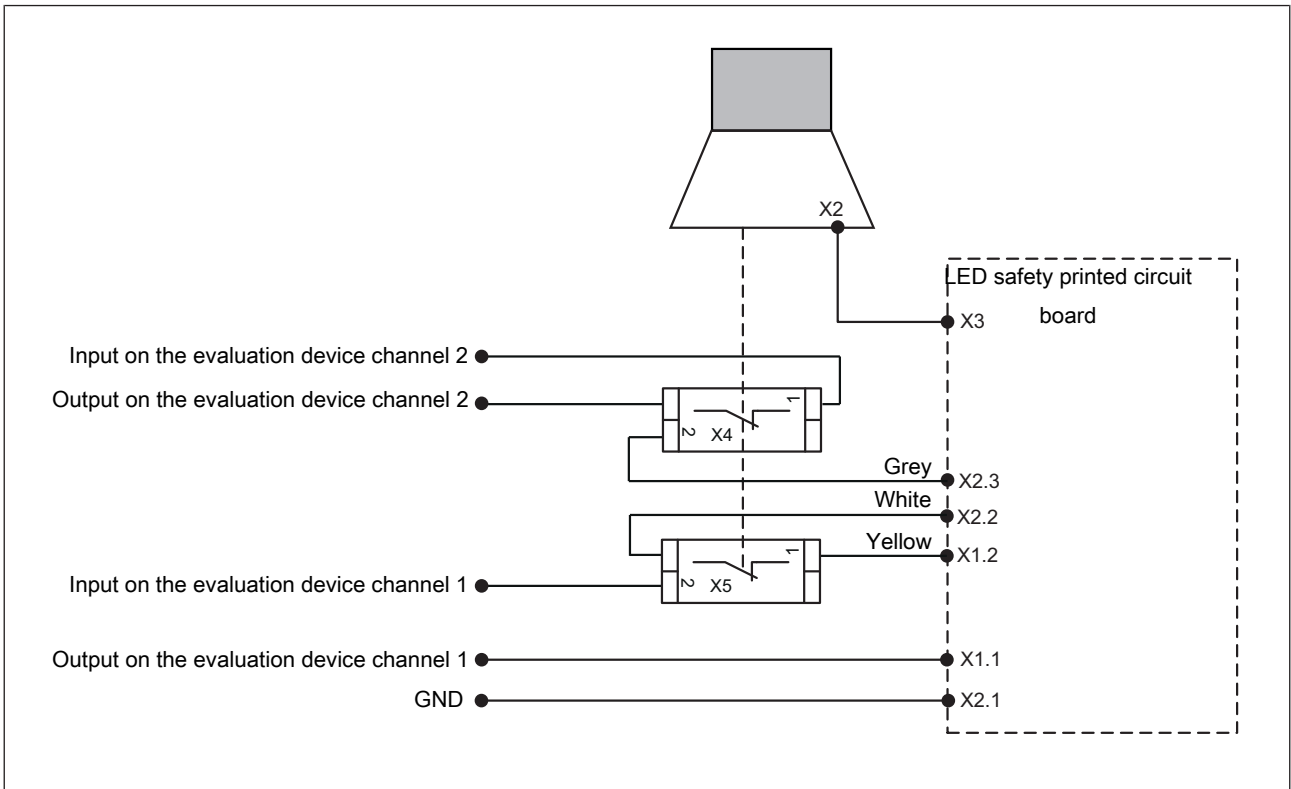

Fig.: Connection example, flashing function is active

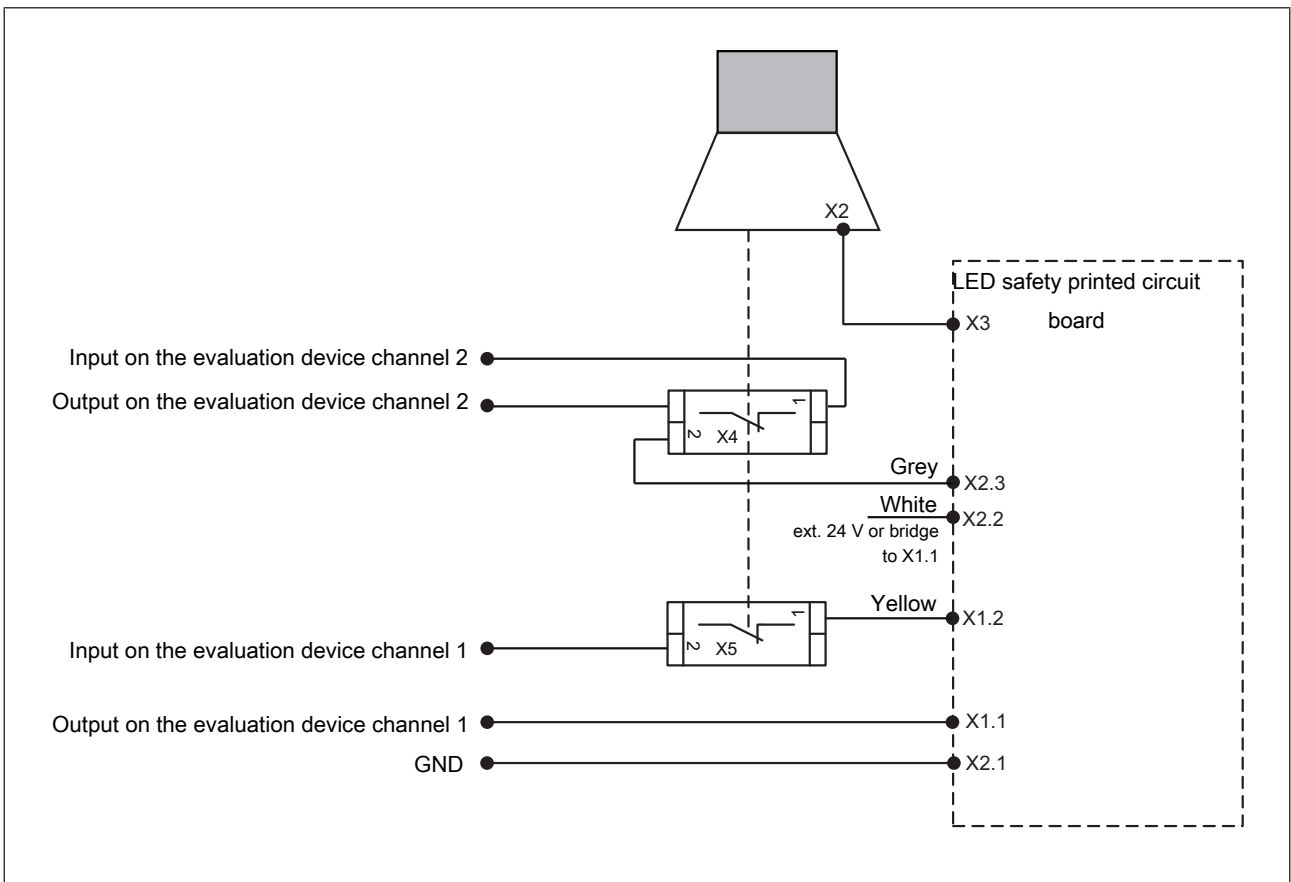

Fig.: Connection example, flashing function is not active

### Wiring table

- ▶ Connection of the LED safety printed circuit board to the contact blocks and to the evaluation device

Connection LED safety printed circuit board	Function description	To connect with	Typical signal name
X1.1	Input for input circuit 1, is also used for energy supply	Evaluation device output of channel 1	Test pulse 1/ T0M20/24 V/control output 1/S11
X1.2	Switch output of input circuit 1, the signal is interrupted in case of an error of the LED safety printed circuit board	Contact block X5.1 (yellow cable)	-
X2.1	Ground connection	Ground connection of the evaluation device	GND/A2/0 V
X2.2	Input of the flashing sensor	If a flashing function is required: Output of the contact block X5.2 (white cable). If a flashing function is not required: Connection to 24 V (e.g. X1.1 or external supply)	IMx/lx/controller input 1/ S12
X2.3	Input for input circuit 2, is only used for energy supply	Contact block X4.2 (grey cable)	Test pulse 2/ T1M21/24 V/controller output 2/S21

- ▶ Connection of the contact blocks to the LED safety printed circuit board and to the evaluation device

Connection contact blocks	To connect with	Typical signal name
X4.1	Evaluation device input from channel 2	IMx+1/lx+1/controller input 2/S22
X4.2	LED safety circuit board X2.3 (grey cable) and evaluation device output from channel 2	Test pulse 2/ T1M21/24 V/controller output 2/S21
X5.1	LED safety printed circuit board X1.2 (yellow cable)	-
X5.2	Evaluation device input from channel 1. If a flashing function is required: Connect with LED safety printed circuit board X2.2 (white cable)	IMx/lx/controller input 1/ S12

Examples for connection to Pilz evaluation devices

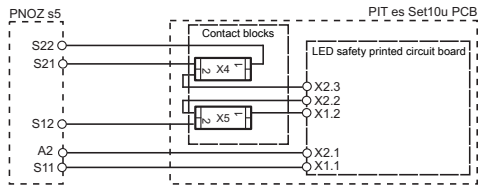
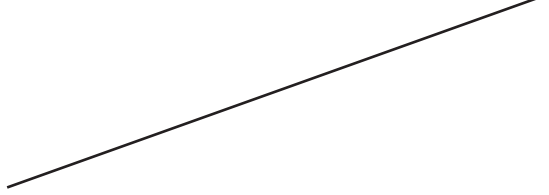
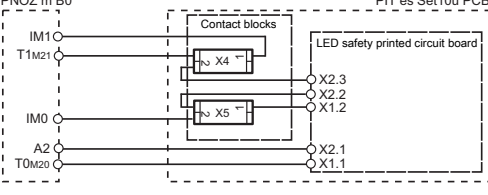
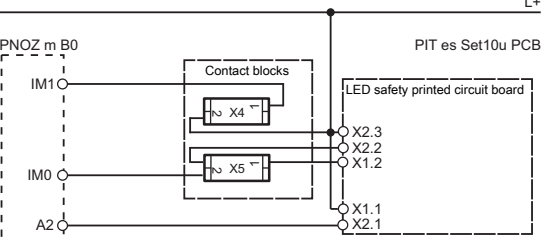
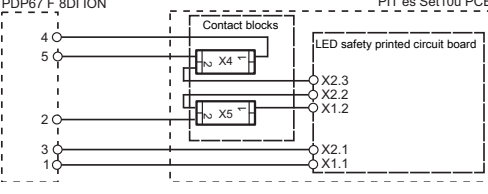
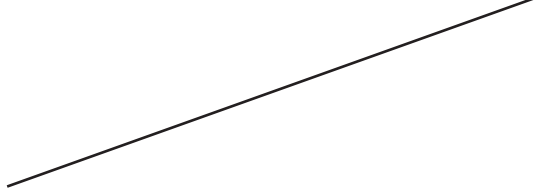
Evaluation device	Internal supply voltage	External supply voltage (24 V)
PNOZ s5		
PNOZ m B0		
PDP67 F 8DI ION		



**NOTICE**

**Check wiring**

Check the function of the E-STOP pushbutton before commissioning the plant/machine by interrupting the GND connection of the LED safety printed circuit board. The evaluation device must switch off then. When an evaluation device does not switch off, there is a wiring error.

**Faults/interference**

- ▶ Failure of the LEDs at the E-STOP pushbutton  
When more than 1 red LED is defective, one of both safety contacts of the E-STOP device will open.  
Remedy: Replace the device.
- ▶ Input voltage at channel 1 and channel 2 too low  
When the input voltage is too low, one of the two safety channels of the E-STOP device will open.
- ▶ Interruption GND  
When the connection to GND is interrupted, one of the two safety contacts of the E-STOP device will open.
- ▶ The operating statuses of the lighting are:
  - Permanent red illumination of the actuator
  - Permanent yellow illumination of the bevelled protective collar

- Flashing yellow illumination of the bevelled protective collar after operating the E-STOP device

With all other statuses the wiring must be checked and the E-STOP device must be exchanged, if necessary.

### Care and maintenance

During operation, the light sources lose brightness. The device is equipped with sufficient brightness for a service life of 20 years. Check at regular intervals whether the lighting of the E-STOP pushbutton is still clearly visible, however at least once per year as part of the function test. Dust, soot and other deposits have an influence on brightness. If necessary, the E-STOP pushbutton must be cleaned or the device must be exchanged.

### Dimensions in mm

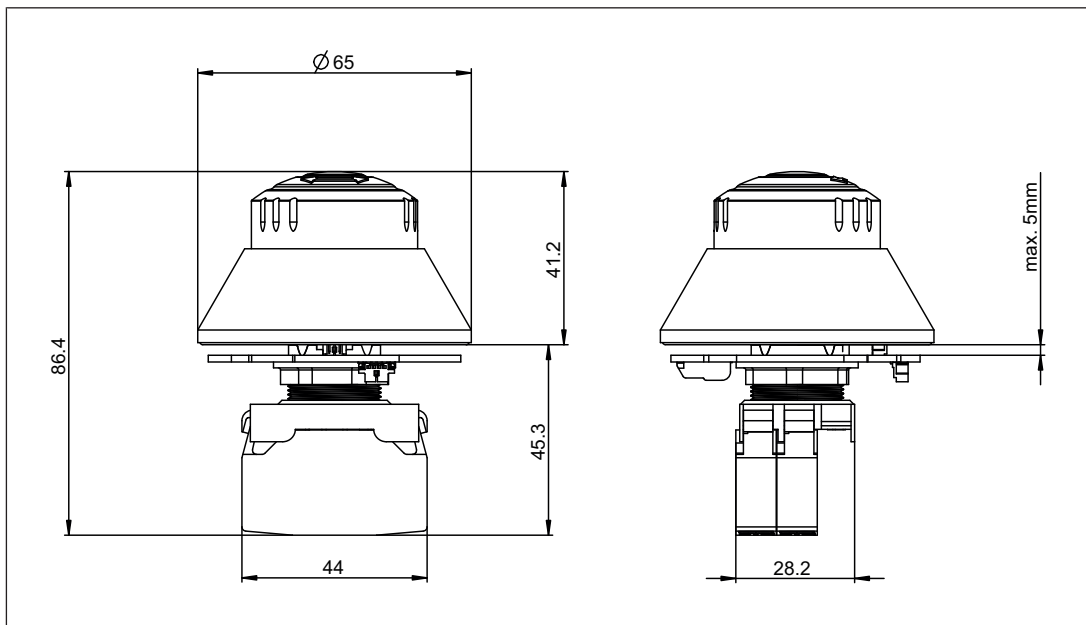

## Technical details

### General

Lamp

Kind	LED
Colour	Yellow, red

### Electrical data

Rated operating voltage	24 V DC
Voltage tolerance	-20% / +15%
Power consumption	2,1 W
Conditional short circuit current	100 A
Protection class	III
Power dissipation	0,7 W

### E-STOP

E-STOP release type	Turn release
Minimum operating current	5 mA
Voltage drop (U <sub>d</sub> )	0,5 V
Residual current (I <sub>r</sub> )	3 µA
Utilisation category	
In accordance with the standard	EN 60947-5-1
DC13 at	24 V
Current	0,3 A
Conventional thermal current	0,3 A
Contact fuse protection, blow-out fuse quick	≤ 1 A
Contact material	AgNi
Mechanical life	6050 cycles
Bounce time	10 ms

### Environmental data

Ambient temperature	
Temperature range	-25 - 55 °C
Storage temperature	
Temperature range	-25 - 75 °C
Vibration	
In accordance with the standard	EN 60947-5-5
Frequency	10 - 500 Hz
Amplitude	max. 0,35 mm
Acceleration	max. 50 m/s <sup>2</sup>
Airgap creepage	
In accordance with the standard	EN 60947-5-1
Overvoltage category	II
Pollution degree	2
Rated insulation voltage	50 V
Rated impulse withstand voltage	0,5 kV



**Environmental data**

Protection type	
Front	<b>IP65</b>
Mounting area (e.g. control cabinet)	<b>≥ IP54</b>

**Mechanical data**

Mounting position	<b>Any</b>
Connection type	<b>Spring-loaded terminal</b>
Dimensions	
Height	<b>86,4 mm</b>
Width	<b>65 mm</b>
Depth	<b>65 mm</b>
Weight	<b>92 g</b>

Where standards are updated, the 2017-08 latest editions shall apply.

**Safety characteristic data**



**NOTICE**

You must comply with the safety characteristic data in order to achieve the required safety level for your plant/machine.

Operating mode	EN ISO 13849-1: 2015	EN ISO 13849-1: 2015	EN ISO 13849-1: 2015	EN ISO 13849-1: 2015
			PFH <sub>D</sub> [1/h]	T <sub>M</sub> [year]
Perceptibility of red illumination in defined ambient conditions	<b>PL d</b>	<b>Cat. 2</b>	<b>3,00E-07</b>	<b>20</b>

Operating mode	<b>EN ISO 13849-1: 2015</b>
	<b>B10d</b>

N/C contacts	<b>100.000</b>
--------------	----------------

All the units used within a safety function must be considered when calculating the safety characteristic data.

Please note that the Performance Level in accordance with EN 13849-1 can be reduced because of reduced fault detection when several E-STOP devices are cascaded.



**NOTICE**

Only one PIT es Set10u may be used per circuit (no cascading).

**INFORMATION**

A safety function's SIL/PL values are **not** identical to the SIL/PL values of the units that are used and may be different. We recommend that you use the PAScal software tool to calculate the safety function's SIL/PL values.

**Supplementary data****Permitted operating height**

The values stated in the technical details apply to the use of the device in operating heights up to max. 2000 m above sea level. When used in greater heights, constraints have to be taken into account:

- ▶ Permitted maximum operating height 5000 m
- ▶ From an operating height of 2000 m the max. permitted ambient temperature is reduced by 0.5 °C/100 m

Operating height	Permitted ambient temperature
3000 m	50 °C
4000 m	45 °C
5000 m	40 °C

## Order reference

### Product

#### Set

Product type	Features	Order no.
PIT es Set10u-5c PCB	Set consisting of E-STOP pushbutton that can be activated/deactivated without logo and without E-STOP symbol, with LED safety circuit board with integral flashing function, contact block and cable set, 2 N/C (connection in Push-in technology)	400 460

#### E-STOP pushbutton

Product type	Features	Order no.
PIT es10u	E-STOP pushbutton can be activated/deactivated without logo and without E-STOP symbol	400 540

#### LED safety printed circuit board

Product type	Features	Order no.
PIT EF LED 1 PCB	LED safety printed circuit board for PIT es10u	400 342

#### Contact block and bracket

Product type	Features	Order no.
PIT esc2c	1 N/C, spring-loaded terminal	400 321
PIT es holder3c	Bracket for containing 3 contact blocks with spring-loaded terminals	400 331

#### Accessories

Product type	Features	Order no.
PIT es wrench	Installation wrench for PIT es pushbutton	400 222

## EC declaration of conformity

This product/these products meet the requirements of the directive 2006/42/EC for machinery of the European Parliament and of the Council. The complete EC Declaration of Conformity is available on the Internet at [www.pilz.com/downloads](http://www.pilz.com/downloads).

Authorised representative: Norbert Fröhlich, Pilz GmbH & Co. KG, Felix-Wankel-Str. 2, 73760 Ostfildern, Germany

# ► Support

Technical support is available from Pilz round the clock.

## Americas

### Brazil

+55 11 97569-2804

### Canada

+1 888-315-PILZ (315-7459)

### Mexico

+52 55 5572 1300

### USA (toll-free)

+1 877-PILZUSA (745-9872)

## Asia

### China

+86 21 60880878-216

### Japan

+81 45 471-2281

### South Korea

+82 31 450 0680

## Australia

+61 3 95600621

## Europe

### Austria

+43 1 7986263-0

### Belgium, Luxembourg

+32 9 3217575

### France

+33 3 88104000

### Germany

+49 711 3409-444

### Ireland

+353 21 4804983

### Italy, Malta

+39 0362 1826711

## Scandinavia

+45 74436332

## Spain

+34 938497433

## Switzerland

+41 62 88979-30

## The Netherlands

+31 347 320477

## Turkey

+90 216 5775552

## United Kingdom

+44 1536 462203

## You can reach our international hotline on:

+49 711 3409-444

support@pilz.com

Pilz develops environmentally-friendly products using ecological materials and energy-saving technologies. Offices and production facilities are ecologically designed, environmentally-aware and energy-saving. So Pilz offers sustainability, plus the security of using energy-efficient products and environmentally-friendly solutions.



Pilz GmbH & Co. KG  
Felix-Wankel-Straße 2  
73760 Ostfildern, Germany  
Tel.: +49 711 3409-0  
Fax: +49 711 3409-133  
info@pilz.com  
www.pilz.com

**PILZ**  
THE SPIRIT OF SAFETY

CMSE®, InduraNET p®, PAS4000®, PASscal®, PASconfig®, Pilz®, PIT®, PLID®, PMCPirotego®, PMCiendo®, PMD®, PMI®, PNOZ®, Pirmo®, PSEN®, PSENi®, PSS®, PVIS®, SafetyBUS SafetyEYE®, SafetyNET p®, THE SPIRIT OF SAFETY® are registered and protected trademarks of Pilz GmbH & Co. KG in some countries. We would point out that product features mentioned in the details stated in this document, depending on the status at the time of publication and the scope of the equipment. We accept no responsibility for the validity, accuracy and entirety of the text and graphics presented in this information. Please contact our Technical Support if you have any questions.