



Visualisation; Diagnostics

Easy to Configure

Programming IEC 61131-3

Rapid Installation

PIT es Set10u-5ns (AIDA) basic

PILZ

THE SPIRIT OF SAFETY

► Control and signal devices

This document is the original document.

Where unavoidable, for reasons of readability, the masculine form has been selected when formulating this document. We do assure you that all persons are regarded without discrimination and on an equal basis.

All rights to this documentation are reserved by Pilz GmbH & Co. KG. Copies may be made for the user's internal purposes. Suggestions and comments for improving this documentation will be gratefully received.

Pilz®, PIT®, PMI®, PNOZ®, Primo®, PSEN®, PSS®, PVIS®, SafetyBUS p®, SafetyEYE®, SafetyNET p®, the spirit of safety® are registered and protected trademarks of Pilz GmbH & Co. KG in some countries.



SD means Secure Digital

Introduction	5
Validity of documentation	5
Using the documentation	5
Definition of symbols	5
Overview	6
Device features	6
Marking on E-STOP pushbutton	6
Safety	7
Intended use	7
Safety regulations	8
Safety assessment	8
Use of qualified personnel	9
Warranty and liability	9
Disposal	9
For your safety	9
Block diagram/terminal configuration	10
Function description	10
Operating states	10
Installation	11
Wiring	13
Preparing for operation	13
Assignment of the 5-pin M12 male connector	13
Requirements and connection to evaluation devices	14
Examples for connection to Pilz evaluation devices	15
Faults/interference	16
Care and maintenance	16
Dimensions in mm	17
Technical details	18
Safety characteristic data	19
Supplementary data	20
Permitted operating height	20
Order reference	20
Product	20
Accessories	21

Mounting bracket	21
Open-ended connection cable	21
Connection cable for connection to decentralised modules	22
EC declaration of conformity	22
UKCA-Declaration of Conformity	23

Introduction

Validity of documentation

This documentation is valid for the product PIT es Set10u-5ns (AIDA) basic. It is valid until new documentation is published.

This operating manual explains the function and operation, describes the installation and provides guidelines on how to connect the product.

Using the documentation

This document is intended for instruction. Only install and commission the product if you have read and understood this document. The document should be retained for future reference.

Definition of symbols

Information that is particularly important is identified as follows:



DANGER!

This warning must be heeded! It warns of a hazardous situation that poses an immediate threat of serious injury and death and indicates preventive measures that can be taken.



WARNING!

This warning must be heeded! It warns of a hazardous situation that could lead to serious injury and death and indicates preventive measures that can be taken.



CAUTION!

This refers to a hazard that can lead to a less serious or minor injury plus material damage, and also provides information on preventive measures that can be taken.



NOTICE

This describes a situation in which the product or devices could be damaged and also provides information on preventive measures that can be taken. It also highlights areas within the text that are of particular importance.



INFORMATION

This gives advice on applications and provides information on special features.

Overview

Device features

- ▶ E-STOP device in accordance with EN 60204-1, EN ISO 13849, EN ISO 13850 and EN 60947-5-5, contacts in accordance with EN 60947-5-1
- ▶ Clear visual display when E-STOP function is active
- ▶ In inactive state, the E-STOP pushbutton is not lit and it can no longer be detected as an E-STOP
- ▶ Turn in either direction to release
- ▶ Bevelled protective collar
- ▶ Integral flashing function of the yellow bevelled protective collar after operating the E-STOP pushbutton
- ▶ Connection to an evaluation device via 5-pin M12 connector

Marking on E-STOP pushbutton

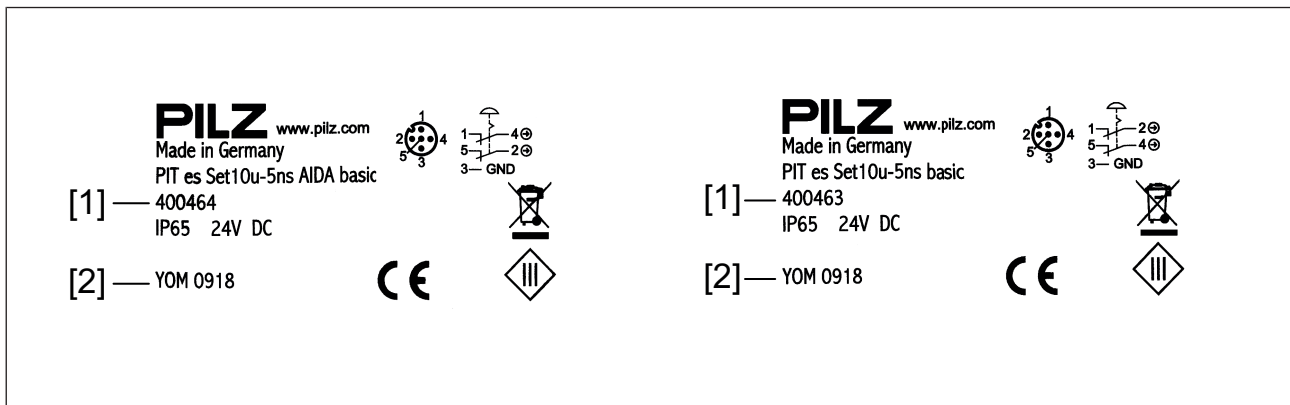

Legend

- [1] Order number
- [2] Date of manufacture mmyy

Safety

Intended use

The E-STOP function is triggered by operating the active E-STOP device and the voltage to the evaluation device is interrupted (dual-channel, fully operated).

In active state, the E-STOP device PIT es Set10u-5ns (AIDA) basic is lit (the actuator lights up red) and it fulfils the requirements in accordance with EN ISO 13850.

In inactive state, the E-STOP pushbutton PIT es Set10u-5ns (AIDA) basic is not lit and it can not be detected as an emergency stop device. The E-STOP function is deactivated.

The safety function of the E-STOP device is:

- ▶ Ensuring that the red lighting can be detected under defined environmental conditions. In case of a lighting failure of the active E-STOP device's lightings, the E-STOP function is triggered and the voltage to the evaluation device is interrupted (single-channel, partially operated).



CAUTION!

It must not be possible to defeat the E-STOP pushbuttons. Otherwise material damage and severe injuries may result, depending on the application.

The E-STOP pushbutton must **not** be used in place of other safety measures.



WARNING!

Loss of the safety function by deactivating the E-STOP device

Deactivating the E-STOP device may result in serious injury and death. The E-STOP function can only be deactivated when the plant/machine is in an operating mode that does not become dangerous to the operator, or when the safety function is implemented by other measures.



NOTICE

The E-STOP device must be used only in the inner area and it must be protected from direct sunlight. Its brightness covers the scope of the workplace regulations ASR A3.4 for common industrial environment.



NOTICE

The E-STOP device must not be used in an atmosphere with a high degree of hydrogen sulphide (H₂S), e.g. in sewage plants and farms.



NOTICE

Only one PIT es Set10u may be used per circuit (no cascading).

Improper use

The following is deemed improper use in particular

- ▶ Any component, technical or electrical modification to the product,
- ▶ Use of the product outside the areas described in this operating manual,
- ▶ Use of the product outside the technical details (see [Technical details](#)  18]).



NOTICE

EMC-compliant electrical installation

The product is designed for use in an industrial environment. The product may cause interference if installed in other environments. If installed in other environments, measures should be taken to comply with the applicable standards and directives for the respective installation site with regard to interference.

Safety regulations

Safety assessment

Before using a device, a safety assessment in accordance with the Machinery Directive is required.

The product as an individual component fulfils the functional safety requirements in accordance with EN ISO 13849 and EN 62061. However, this does not guarantee the functional safety of the overall plant/machine. To achieve the relevant safety level of the overall plant/machine's required safety functions, each safety function needs to be considered separately.

Use of qualified personnel

The products may only be assembled, installed, programmed, commissioned, operated, maintained and decommissioned by persons who are competent to do so.

A competent person is a qualified and knowledgeable person who, because of their training, experience and current professional activity, has the specialist knowledge required. To be able to inspect, assess and operate devices, systems and machines, the person has to be informed of the state of the art and the applicable national, European and international laws, directives and standards.

It is the company's responsibility only to employ personnel who

- ▶ Are familiar with the basic regulations concerning health and safety / accident prevention,
- ▶ Have read and understood the information provided in the section entitled Safety
- ▶ Have a good knowledge of the generic and specialist standards applicable to the specific application.

Warranty and liability

All claims to warranty and liability will be rendered invalid if

- ▶ The product was used contrary to the purpose for which it is intended,
- ▶ Damage can be attributed to not having followed the guidelines in the manual,
- ▶ Operating personnel are not suitably qualified,
- ▶ Any type of modification has been made (e.g. exchanging components on the PCB boards, soldering work etc.).

Disposal

- ▶ In safety-related applications, please comply with the mission time T_M in the safety-related characteristic data.
- ▶ When decommissioning, please comply with local regulations regarding the disposal of electronic devices (e.g. Electrical and Electronic Equipment Act).

For your safety

The unit meets all the necessary conditions for safe operation. However, please note the following:

- ▶ Check the function of the pushbutton before commissioning for the first time and then at regular intervals (at least annually).

Block diagram/terminal configuration

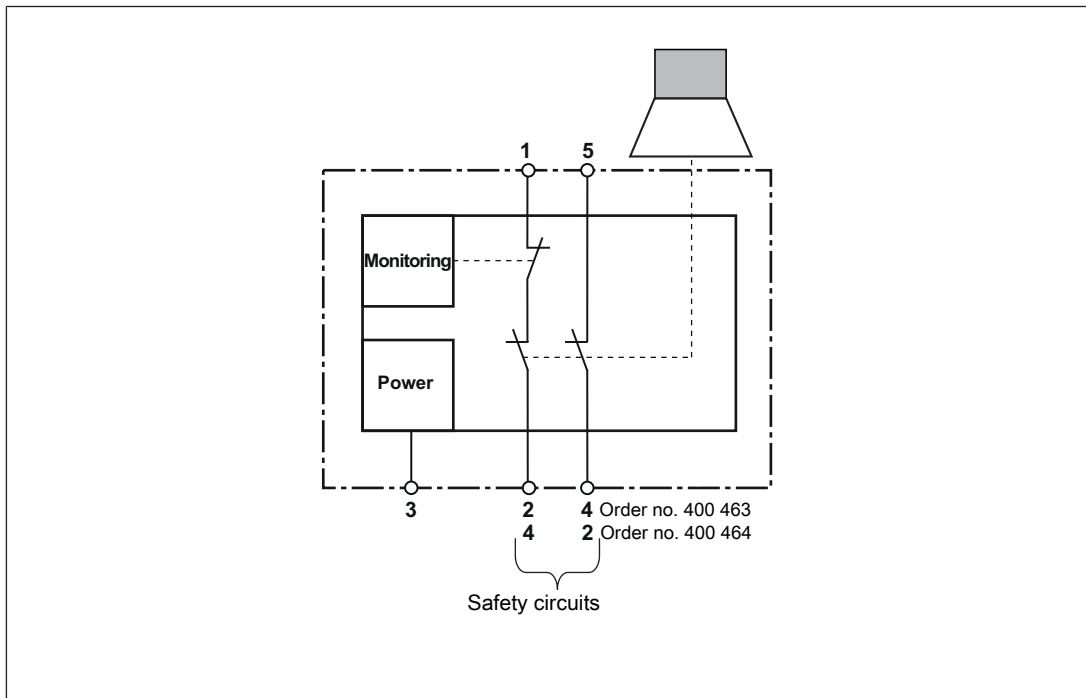

Function description



INFORMATION

In the section below, the connection designations outside of the brackets refer to the E-STOP device with order no. 400 463; the designations inside the brackets refer to the E-STOP device with order no. 400 464.

The E-STOP device is active when actuator and bevelled protective collar are lit. If the E-STOP device is operated, both safety circuits 1-2 (1-4) and 5-4 (5-2) will open. The actuator is locked. The bevelled protective collar flashes yellow.

The E-STOP function must be reset deliberately by unlocking the actuator (turn to the left or right).

The E-STOP function is inactive when the connections 1 (1) and 5 (5) are disconnected from the supply. The lighting goes out, the E-STOP device is without function.

The E-STOP device detects if the red lighting is defective and opens the safety circuit 1-2 (1-4).

Operating states

- ▶ **Active:** The E-STOP device is electrically supplied and it is not operated. The actuator is illuminated red, the bevelled protective collar is illuminated yellow.
- ▶ **Inactive:** The E-STOP device is not electrically supplied and it is therefore not illuminated.

- ▶ **Triggered:** The E-STOP device is in active state, the actuator has been pressed and it is therefore locked. The two safety circuits are opened (fully operated). The actuator is illuminated red, the bevelled protective collar flashes yellow.

Installation



CAUTION!

Always install the device with the supply voltage switched off.

- ▶ Prepare two fixing holes for M4 screws on the mounting plate.

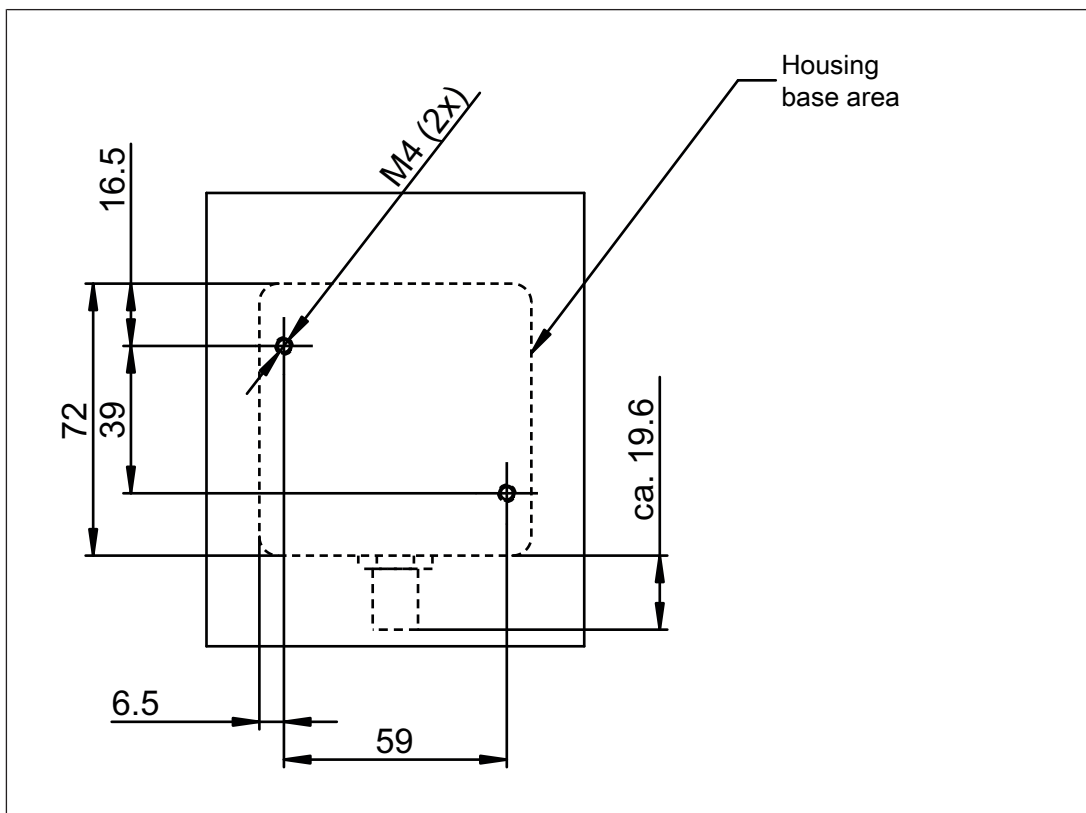

- ▶ Undo the four cross head screws on the housing faceplate and remove the housing faceplate.



NOTICE

In an open state, the electronics contained within the housing are no longer protected against environmental influences. In particular you should avoid humidity, electrostatic discharge and the ingress of foreign bodies.

- ▶ Use M4 screws to attach the housing subplate. Use an appropriate screw adhesive (e.g. Loctite) to protect the screws from working loose.
- ▶ Place the housing faceplate back on the housing subplate and screw them in place.

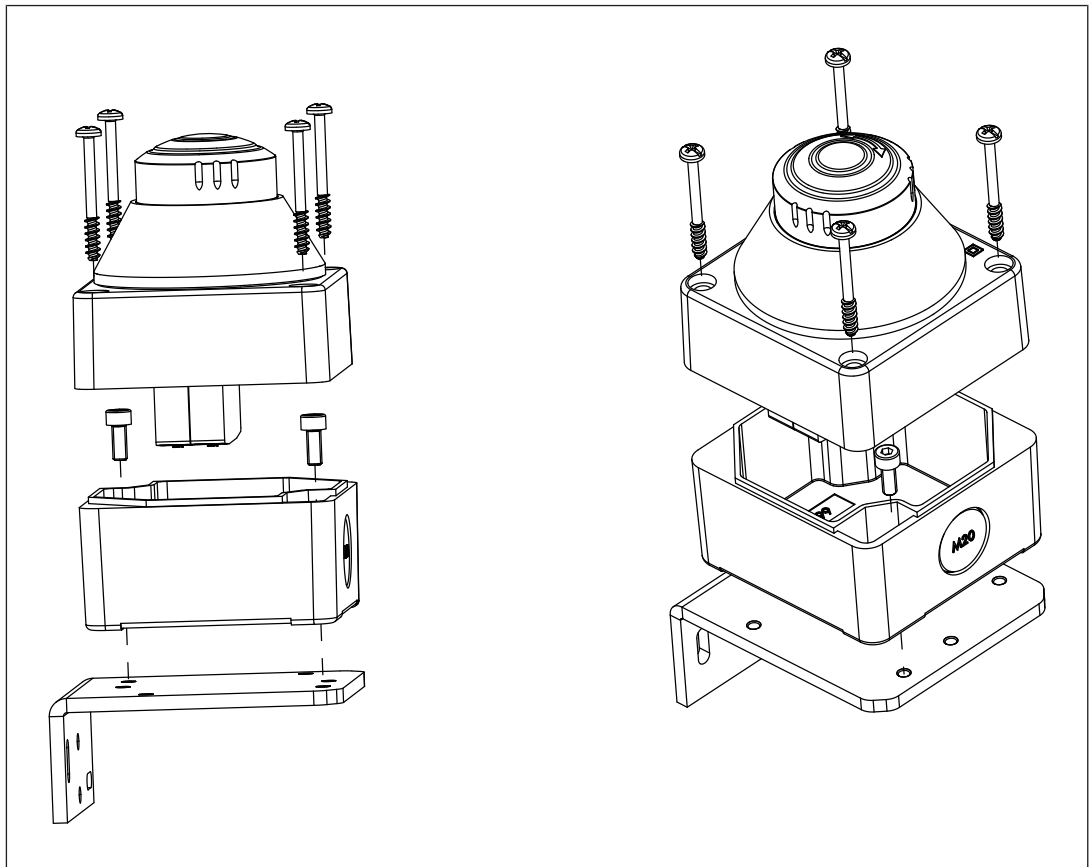

Fig.: Installation including mounting bracket



NOTICE

Damage due to electrostatic discharge!

Electrostatic discharge can damage components. Ensure against discharge before touching the product, e.g. by touching an earthed, conductive surface or by wearing an earthed armband.



NOTICE

Take care not to damage the internal connection cables during installation. The housing faceplate must be installed in the exact condition in which it was supplied and must not be twisted. No changes should be made to the internal wiring. Make sure that no foreign bodies enter the housing during installation.



NOTICE

Before closing the housing, check that the seal is fitted correctly and ensure that the housing screws have a torque setting of 1.2 Nm.

Wiring

Please note:

- ▶ Information given in the "[Technical details \[18\]](#)" must be followed.
- ▶ The power supply must meet the regulations for PELV in accordance with EN 60204-1.
- ▶ The maximum cable length depends on the conductor cross section used and the current requirement of the connected evaluation device. In a maximum current consumption of 100 mA, plus the current of the input circuits of the evaluation device, a rated operating voltage of 24 V (tolerance: -20 %/+15 %, that is at least 19.2 V) must be available.
- ▶ Only one PIT es Set10u may be used per circuit. However, it may be cascaded with conventional electromechanical E-STOP devices that have only N/C contacts. Note that when operating a conventional E-STOP device which is in the chain before the PIT es Set10u-5ns (AIDA) basic, the PIT es Set10u-5ns (AIDA) basic is not electrically supplied and therefore it is not illuminated.

Preparing for operation



NOTICE

Check the function of the emergency stop device before commissioning for the first time and then at regular intervals (at least annually).

Assignment of the 5-pin M12 male connector

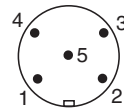

PIN	Function	
	Order no. 400 463	Order no. 400 464
1	Safety contact/test pulse channel 1	Safety contact/test pulse channel 1
2	Safety contact channel 1	Safety contact channel 2
3	0 V U _B	0 V U _B
4	Safety contact channel 2	Safety contact channel 1
5	Safety contact/test pulse channel 2	Safety contact/test pulse channel 2

Requirements and connection to evaluation devices

For use of PIT es Set10u-5ns (AIDA) basic an evaluation device must be connected.

Connect the PIT es Set10u-5ns (AIDA) basic

- ▶ either with a Pilz evaluation device
- ▶ or with an evaluation device with defined properties (see section Defined properties of evaluation devices:)

Suitable Pilz evaluation devices are, for example:



- ▶ PNOZelog for E-STOP monitoring
 - PNOZ e1.1p (Order No. 774 133)
- ▶ PNOZ X for safety gate monitoring
 - PNOZ X2.8P (Order No. 777 301 and 787 301)
- ▶ PNOZsigma for safety gate monitoring
 - PNOZ s5 (Order No. 750 105 and 751 105)
- ▶ PNOZmulti for E-STOP monitoring
 - PNOZ m B0 (Order No. 772 100)
- ▶ PSSuniversal
 - PSSu E F 4DI (Order No. 312 200)
- ▶ Decentralised periphery
 - PDP67 F 8DI ION (Order No. 773 600)

Defined properties of evaluation devices:

- ▶ Dual-channel with detection of partial operation (only one channel of the input circuit is open)
- ▶ Detection of shorts across contacts and earth fault detection: Detection of shorts across contacts is possible also via a positive and negative input circuit
- ▶ Digital inputs type 2 in accordance with IEC 61131-2
- ▶ Offset test pulses (not overlapping) with a maximum duration of the on/off test pulse of 7.5 ms

Connect the evaluation device as described in the evaluation device's operating manual.

Please note:

- ▶ Protective separation of the outputs to voltages over 60 V
- ▶ The power supply that feeds the evaluation device must meet the regulations for PELV in accordance with EN 60204-1.
- ▶ The evaluation device must meet the requirements in the [Technical details](#)  18]. The specified values must not be exceeded.
- ▶ The LED safety printed circuit board built into the unit contains two permanently installed blow-out fuses. If the fuses are tripped by overcurrent or overvoltage, the LED safety printed circuit board must be exchanged (see [Order reference](#)  20]).

Ensure the wiring and EMC requirements of IEC 60204-1 are met.

To connect the evaluation device to the E-STOP device, use a 5-pin unshielded cable with an A-coded M12 female connector (see [Order reference](#)  20] "Open-ended connection cable").

To connect a decentralised module (e.g. PDP67 F 8DI ION from Pilz), use a 5-pin unshielded cable with an A-coded M12 male connector (for connection to the decentralised module) and an A-coded M12 female connector (for connection to the E-STOP device) (see [Order reference \[20\]](#) "Connection cable for connection to decentralised modules").

Examples for connection to Pilz evaluation devices

Evaluation device	Internal supply voltage	External supply voltage (24 V)
PNOZ s5		
PNOZ m B0		
PDP67 F 8DI ION		



NOTICE
Check wiring

Particularly if you are using an open-ended cable, check the function of the E-STOP pushbutton before commissioning the plant/machine by interrupting the GND connection of PIN 3. The evaluation device must then switch off. When an evaluation device does not switch off, there is a wiring error.

Faults/interference

- ▶ Failure of the LEDs at the E-STOP pushbutton
When more than 1 red LED is defective, one of both safety contacts of the E-STOP device will open.
Remedy: Replace the device.
 - ▶ Input voltage at channel 1 and channel 2 too low
When the input voltage is too low, one of the two safety channels of the E-STOP device will open.
 - ▶ Interruption GND
If the connection to GND is interrupted, one of the two safety contacts of the E-STOP device will open.
 - ▶ The operating statuses of the lighting are:
 - Permanent red illumination of the actuator
 - Permanent yellow illumination of the bevelled protective collar
 - Flashing yellow illumination of the bevelled protective collar after operating the E-STOP device
- With all other statuses the wiring must be checked and the E-STOP device must be exchanged, if necessary.

Care and maintenance

During operation, the light sources lose brightness. The device is equipped with sufficient brightness for a service life of 20 years. Check at regular intervals whether the lighting of the E-STOP pushbutton is still clearly visible, however at least once per year as part of the function test. Dust, soot and other deposits have an influence on brightness. If necessary, the E-STOP pushbutton must be cleaned or the device must be exchanged.

Dimensions in mm

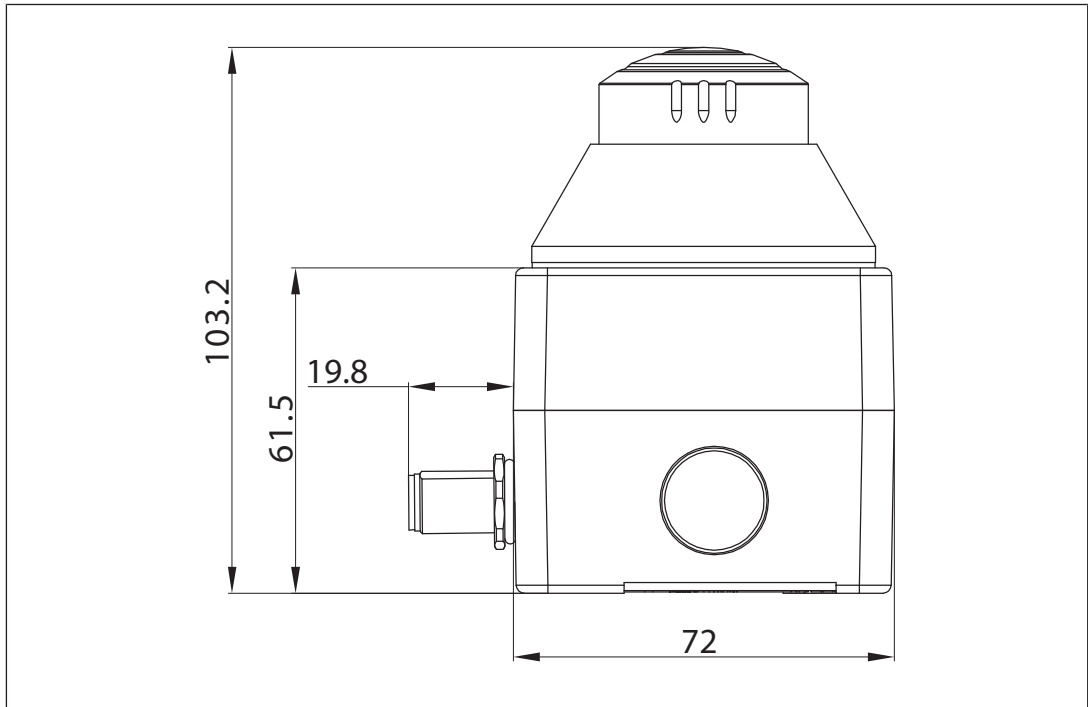

► Mounting bracket (order no. 400 220)

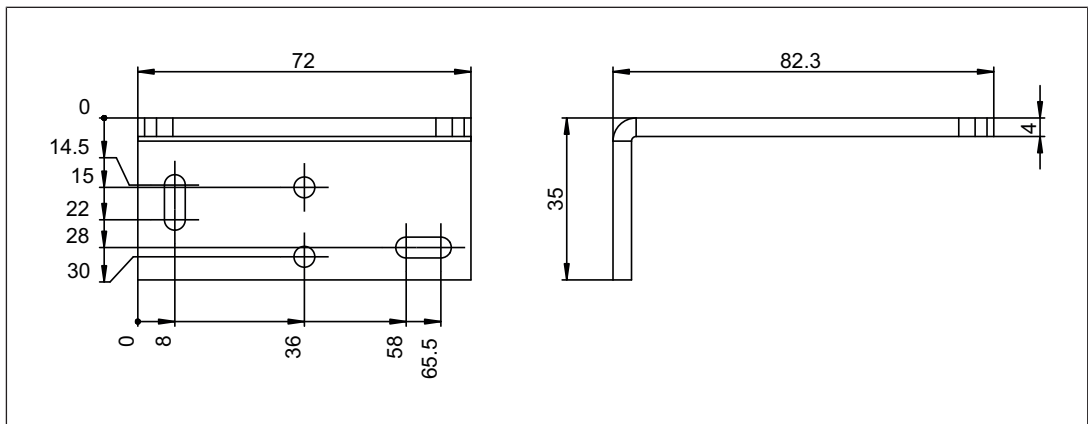

Technical details

General	400463	400464
Certifications	CE, UKCA	CE, UKCA
Lamp		
Kind	LED	LED
Colour	Yellow, red	Yellow, red
Electrical data	400463	400464
Rated operating voltage	24 V DC	24 V DC
Voltage tolerance	-20% / +15%	-20% / +15%
Power consumption	2,1 W	2,1 W
Conditional short circuit current	100 A	100 A
Protection class	III	III
E-STOP	400463	400464
E-STOP release type	Turn release	Turn release
Minimum operating current	5 mA	5 mA
Voltage drop (U _d)	0,5 V	0,5 V
Residual current (I _r)	3 µA	3 µA
Utilisation category		
In accordance with the standard	EN 60947-5-1	EN 60947-5-1
DC13 at	24 V	24 V
Current	0,3 A	0,3 A
Conventional thermal current	0,3 A	0,3 A
Contact fuse protection, blow-out fuse quick	≤ 1 A	≤ 1 A
Contact material	AgNi	AgNi
Mechanical life	6050 cycles	6050 cycles
Bounce time	10 ms	10 ms
Environmental data	400463	400464
Ambient temperature		
Temperature range	-25 - 55 °C	-25 - 55 °C
Storage temperature		
Temperature range	-25 - 75 °C	-25 - 75 °C
Vibration		
In accordance with the standard	EN 60947-5-5	EN 60947-5-5
Frequency	10 - 500 Hz	10 - 500 Hz
Amplitude	max. 0,35 mm	max. 0,35 mm
Acceleration	max. 50 m/s²	max. 50 m/s²
Airgap creepage		
In accordance with the standard	EN 60947-5-1	EN 60947-5-1
Overvoltage category	II	II
Pollution degree	2	2
Rated insulation voltage	50 V	50 V
Rated impulse withstand voltage	0,5 kV	0,5 kV

Environmental data	400463	400464
Protection type		
Housing	IP65	IP65
Front	IP65	IP65
Mechanical data	400463	400464
Mounting position	Any	Any
Connection type	M12	M12
Dimensions		
Height	103,2 mm	103,2 mm
Width	72 mm	72 mm
Depth	91,8 mm	91,8 mm
Weight	207 g	207 g

Where standards are updated, the 2017-08 latest editions shall apply.

Safety characteristic data



NOTICE

You must comply with the safety characteristic data in order to achieve the required safety level for your plant/machine.

Operating mode	EN ISO 13849-1: 2015	EN ISO 13849-1: 2015	EN ISO 13849-1: 2015	EN ISO 13849-1: 2015
			PFH_D [1/h]	T_M [year]
Perceptibility of red illumination in defined ambient conditions	PL d	Cat. 2	3,00E-07	20
Operating mode	B10d in accordance with EN ISO 13849-1: 2015 and EN 62061		T_M [year] in accordance with EN ISO 13849-1:2015	
Perceptibility of red illumination in defined ambient conditions	100.000		20	

Operating mode	EN ISO 13849-1: 2015
	B10d
N/C contacts	100.000

All the units used within a safety function must be considered when calculating the safety characteristic data.

Please note that the Performance Level in accordance with EN 13849-1 can be reduced because of reduced fault detection when several E-STOP devices are cascaded.



NOTICE

Only one PIT es Set10u may be used per circuit (no cascading).



INFORMATION

A safety function's SIL/PL values are **not** identical to the SIL/PL values of the units that are used and may be different. We recommend that you use the PAScal software tool to calculate the safety function's SIL/PL values.

Supplementary data

Permitted operating height

The values stated in the technical details apply to the use of the device in operating heights up to max. 2000 m above sea level. When used in greater heights, constraints have to be taken into account:

- ▶ Permitted maximum operating height 5000 m
- ▶ From an operating height of 2000 m the max. permitted ambient temperature is reduced by 0.5 °C/100 m

Operating height	Permitted ambient temperature
3000 m	50 °C
4000 m	45 °C
5000 m	40 °C

Order reference

Product

Sets

Product type	Features	Order no.
PIT es Set10u-5ns basic	Set consisting of E-STOP pushbutton active/inactive with flash function, without logo and without E-STOP symbol, with contact block and with LED safety printed circuit board in basic surface mount housing with 5-pin M12 plug connection, 2 N/C (push-in technology connection)	400 463
PIT es Set10u-5ns AIDA basic	Set consisting of E-STOP pushbutton active/inactive with flash function, without logo and without E-STOP symbol, with contact block and with LED safety printed circuit board in basic surface mount housing with 5-pin M12 plug connection - AIDA PIN assignment; 2 N/C (push-in technology connection)	400 464

Emergency stop pushbutton

Product type	Features	Order no.
PIT es10u	E-STOP pushbutton can be activated/deactivated without logo and without E-STOP symbol	400540

LED safety printed circuit board

Product type	Features	Order no.
PIT EF LED 1 PCB	LED safety printed circuit board for PIT es10u	400342

Accessories

Mounting bracket

Product type	Features	Order no.
PIT es box flex bracket	Mounting bracket for PIT es box flex	400220

Open-ended connection cable

Product type	Features	Connector X1	Connector X2	Connector X3	Order no.
PSEN op cable axial M12 5-pole 30m	30 m	M12, 5-pin female connector, straight			630297
PSEN cable M12-5sf 20m	20 m	M12, 5-pin female connector, straight			630298
PSEN op cable axial M12 5-pole 3m	3 m	M12, 5-pin female connector, straight			630310
PSEN op cable axial M12 5-pole 5m	5 m	M12, 5-pin female connector, straight			630311
PSEN op cable axial M12 5-pole 10m	10 m	M12, 5-pin female connector, straight			630312
PSEN op cable angle M12 5-pole 3m	3 m	M12, 5-pin female connector, angled			630347
PSEN op cable angle M12 5-pole 5m	5 m	M12, 5-pin female connector, angled			630348
PSEN op cable angle M12 5-pole 10m	10 m	M12, 5-pin female connector, angled			630349
PSEN op cable angle M12 5-pole 30m	30 m	M12, 5-pin female connector, angled			630350
PSEN op cable axial M12 5-pole 50m	50 m	M12, 5-pin female connector, straight			630364
PSEN op cable angle M12 5-pole 50m	50 m	M12, 5-pin female connector, angled			630365

Connection cable for connection to decentralised modules

Product type	Features	Connector X1	Connector X2	Connector X3	Order no.
PSS67 Cable M12sf M12sm, 3m	3 m	M12, 5-pin female connector, straight	M12, 5-pin male connector, straight		380208
PSS67 Cable M12sf M12sm, 5m	5 m	M12, 5-pin female connector, straight	M12, 5-pin male connector, straight		380209
PSS67 Cable M12sf M12sm, 10m	10 m	M12, 5-pin female connector, straight	M12, 5-pin male connector, straight		380210
PSS67 Cable M12sf M12sm, 30m	30 m	M12, 5-pin female connector, straight	M12, 5-pin male connector, straight		380211
PSS67 Cable M12af M12am, 3m	3 m	M12, 5-pin female connector, angled	M12, 5-pin male connector, angled		380212
PSS67 Cable M12af M12am, 5m	5 m	M12, 5-pin female connector, angled	M12, 5-pin male connector, angled		380213
PSS67 Cable M12af M12am, 10m	10 m	M12, 5-pin female connector, angled	M12, 5-pin male connector, angled		380214
PSS67 Cable M12af M12am, 30m	30 m	M12, 5-pin female connector, angled	M12, 5-pin male connector, angled		380215
PSS67 cable M12-5sf, M12-5sm, 20m	20 m	M12, 5-pin female connector, straight	M12, 5-pin male connector, straight		380220
PDP67 Cable M12-5sf M12-5sm, 0.5m	0.5 m	M12, 5-pin female connector, straight	M12, 5-pin male connector, straight		380710
PDP67 Cable M12-5sf M12-5sm, 1m	1 m	M12, 5-pin female connector, straight	M12, 5-pin male connector, straight		380711
PDP67 Cable M12-5sf M12-5sm, 1.5m	1.5 m	M12, 5-pin female connector, straight	M12, 5-pin male connector, straight		380712
PDP67 Cable M12-5sf M12-5sm, 2m	2 m	M12, 5-pin female connector, straight	M12, 5-pin male connector, straight		380713

EC declaration of conformity

This product/these products meet the requirements of the directive 2006/42/EC for machinery of the European Parliament and of the Council. The complete EC Declaration of Conformity is available on the Internet at www.pilz.com/downloads.

Authorised representative: Norbert Fröhlich, Pilz GmbH & Co. KG, Felix-Wankel-Str. 2, 73760 Ostfildern, Germany

UKCA-Declaration of Conformity

This product(s) complies with following UK legislation: Supply of Machinery (Safety) Regulation 2008.

The complete UKCA Declaration of Conformity is available on the Internet at www.pilz.com/support/downloads.

Representative: Pilz Automation Technology, Pilz House, Little Colliers Field, Corby, Northamptonshire, NN18 8TJ United Kingdom, eMail: mail@pilz.co.uk

► Support

Technical support is available from Pilz round the clock.

Americas

Brazil

+55 11 97569-2804

Canada

+1 888 315 7459

Mexico

+52 55 5572 1300

USA (toll-free)

+1 877-PILZUSA (745-9872)

Asia

China

+86 21 60880878-216

Japan

+81 45 471-2281

South Korea

+82 31 778 3300

Australia and Oceania

Australia

+61 3 95600621

New Zealand

+64 9 6345350

Europe

Austria

+43 1 7986263-0

Belgium, Luxembourg

+32 9 3217570

France

+33 3 88104003

Germany

+49 711 3409-444

Ireland

+353 21 4804983

Italy, Malta

+39 0362 1826711

Scandinavia

+45 74436332

Spain

+34 938497433

Switzerland

+41 62 88979-32

The Netherlands

+31 347 320477

Turkey

+90 216 5775552

United Kingdom

+44 1536 462203

You can reach our international hotline on:

+49 711 3409-222

support@pilz.com

Pilz develops environmentally-friendly products using ecological materials and energy-saving technologies. Offices and production facilities are ecologically designed, environmentally-aware and energy-saving. So Pilz offers sustainability, plus the security of using energy-efficient products and environmentally-friendly solutions.



We are represented internationally. Please refer to our homepage www.pilz.com for further details or contact our headquarters.

Headquarters: Pilz GmbH & Co. KG, Felix-Wankel-Straße 2, 73760 Ostfildern, Germany
Telephone: +49 711 3409-0, Telefax: +49 711 3409-133, E-Mail: info@pilz.com, Internet: www.pilz.com

PILZ
THE SPIRIT OF SAFETY

1004863-EN-04, 2022-06 Printed in Germany
© Pilz GmbH & Co. KG, 2019

CECE®, CHRE®, CMSE®, InduraNET p®, Leansafe®, Master of Safety®, Master of Security®, PAS4000®, PAScale®, PASconfig®, Pilz®, PIT®, PLID®, PMCprimo®, PMCprotego®, PMCTendo®, PMD®, PMJ®, PNOZ®, PRBM®, PRCM®, PRM®, PRM®, PRM®, PRM®, PSEN®, PSEN®, PSS®, PVS®, SafetyBUS p®, SafetyEYE®, SafetyNET p®, THE SPIRIT OF SAFETY® are registered and protected trademark of Pilz GmbH & Co. KG in some countries. We would point out that product features may vary from the details stated in this document, depending on the status at the time of publication and the scope of the equipment. We accept no responsibility for the validity, accuracy and entirety of the text and graphics presented in this information. Please contact our Technical Support if you have any questions.