



PIT si1.1

PILZ
THE SPIRIT OF SAFETY

- ▶ Control and signal devices

This document is the original document.

Where unavoidable, for reasons of readability, the masculine form has been selected when formulating this document. We do assure you that all persons are regarded without discrimination and on an equal basis.

All rights to this documentation are reserved by Pilz GmbH & Co. KG. Copies may be made for the user's internal purposes. Suggestions and comments for improving this documentation will be gratefully received.

Pilz®, PIT®, PMI®, PNOZ®, Primo®, PSEN®, PSS®, PVIS®, SafetyBUS p®, SafetyEYE®, SafetyNET p®, the spirit of safety® are registered and protected trademarks of Pilz GmbH & Co. KG in some countries.



SD means Secure Digital

Introduction	4
Validity of documentation	4
Using the documentation	4
Definition of symbols	4
Safety	5
Intended use	5
Safety regulations	5
Use of qualified personnel.....	5
Warranty and liability.....	5
Disposal	6
Unit features	6
Function description	6
Installation and wiring	6
Wiring.....	7
Installation.....	7
Connection examples	9
Driven via PNOZmulti.....	9
Driven via PSSuniversal.....	10
Dimensions	10
Technical details	11
Order reference	11

Introduction

Validity of documentation

This documentation is valid for the product PIT si1.1. It is valid until new documentation is published.

This operating manual explains the function and operation, describes the installation and provides guidelines on how to connect the product.

Using the documentation

This document is intended for instruction. Only install and commission the product if you have read and understood this document. The document should be retained for future reference.

Definition of symbols

Information that is particularly important is identified as follows:



DANGER!

This warning must be heeded! It warns of a hazardous situation that poses an immediate threat of serious injury and death and indicates preventive measures that can be taken.



WARNING!

This warning must be heeded! It warns of a hazardous situation that could lead to serious injury and death and indicates preventive measures that can be taken.



CAUTION!

This refers to a hazard that can lead to a less serious or minor injury plus material damage, and also provides information on preventive measures that can be taken.



NOTICE

This describes a situation in which the product or devices could be damaged and also provides information on preventive measures that can be taken. It also highlights areas within the text that are of particular importance.

**INFORMATION**

This gives advice on applications and provides information on special features.

Safety**Intended use**

The muting lamp is intended for use as an indicator in muting operation.

**CAUTION!**

The muting lamp is not monitored. In safety-related applications, its function must be monitored using appropriate means.

The following is deemed improper use in particular:

- ▶ Any component, technical or electrical modification to the product
- ▶ Use of the product outside the areas described in this manual
- ▶ Use of the product outside the technical details (see chapter entitled "Technical details").

Safety regulations**Use of qualified personnel**

The products may only be assembled, installed, programmed, commissioned, operated, maintained and decommissioned by persons who are competent to do so.

A competent person is a qualified and knowledgeable person who, because of their training, experience and current professional activity, has the specialist knowledge required. To be able to inspect, assess and operate devices, systems and machines, the person has to be informed of the state of the art and the applicable national, European and international laws, directives and standards.

It is the company's responsibility only to employ personnel who

- ▶ Are familiar with the basic regulations concerning health and safety / accident prevention,
- ▶ Have read and understood the information provided in the section entitled Safety
- ▶ Have a good knowledge of the generic and specialist standards applicable to the specific application.

Warranty and liability

All claims to warranty and liability will be rendered invalid if

- ▶ The product was used contrary to the purpose for which it is intended,
- ▶ Damage can be attributed to not having followed the guidelines in the manual,
- ▶ Operating personnel are not suitably qualified,
- ▶ Any type of modification has been made (e.g. exchanging components on the PCB boards, soldering work etc.).

Disposal

- ▶ When decommissioning, please comply with local regulations regarding the disposal of electronic devices (e.g. Electrical and Electronic Equipment Act).

Unit features

- ▶ Signal lamp for muting operation
- ▶ Scope of supply:
 - Muting lamp including bulb
 - mounting bracket
 - 2 screws

Function description

In muting mode, the operator must be made aware of the hazard that results from the suspension of the safety function. The muting lamp is designed for this purpose. It illuminates as soon as muting mode is started.

Installation and wiring

The cover must be taken off and the bulb removed for installation and wiring:

- ▶ Turn the cover to the right and pull it off upwards.
- ▶ While applying slight downward pressure, rotate the bulb by approx. 90° to the right and pull it out.

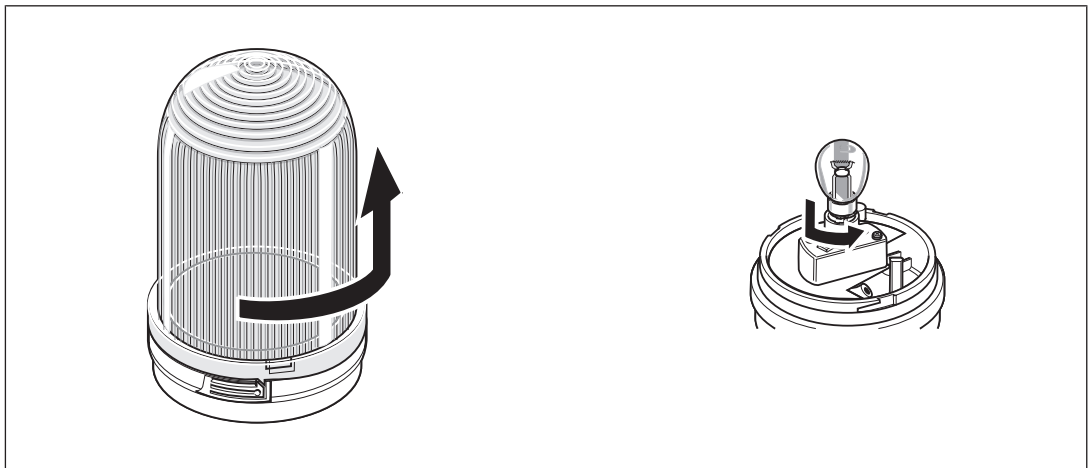

Fig.: Take off the cover and remove the bulb

Wiring



CAUTION!

Wire the lamp when it is isolated from the power supply.

- ▶ Perforate the stuffing box using a screwdriver.
- ▶ The power supply is fastened underneath the bulb holder with the aid of the two screw terminals. Press the terminals beside lamp holder to the side and push the wire into the cut-outs above the holder.

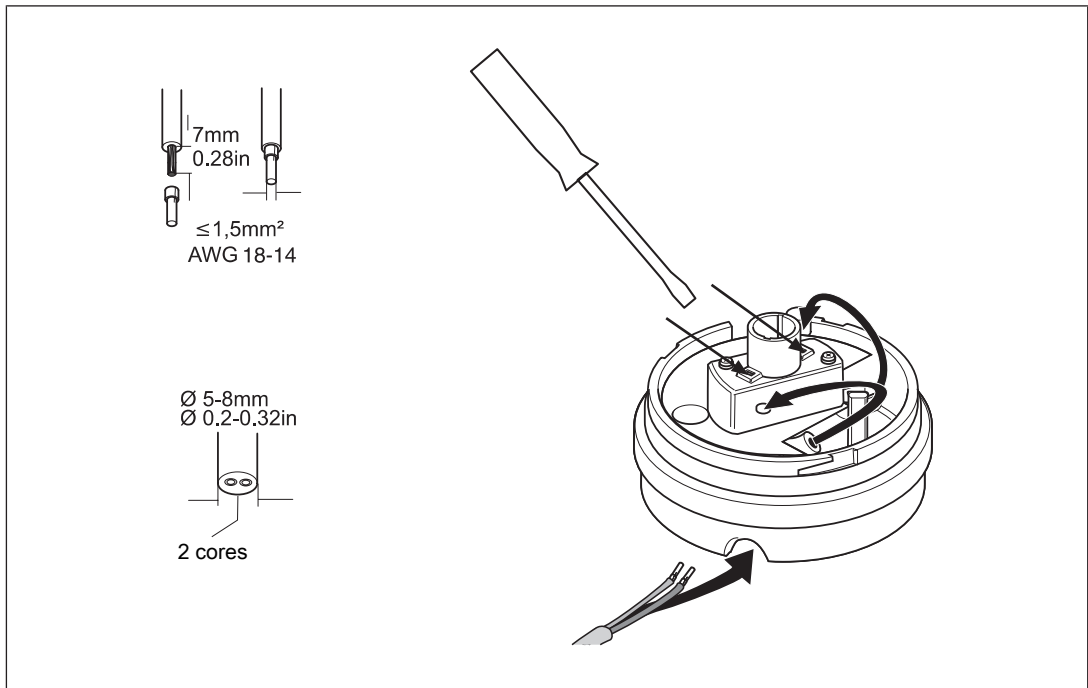

Fig.: Wiring

Installation

- ▶ Install the base directly on a horizontal surface or on the fastening bracket using the two screws supplied.
- ▶ Install the fastening bracket with the base on a vertical surface.

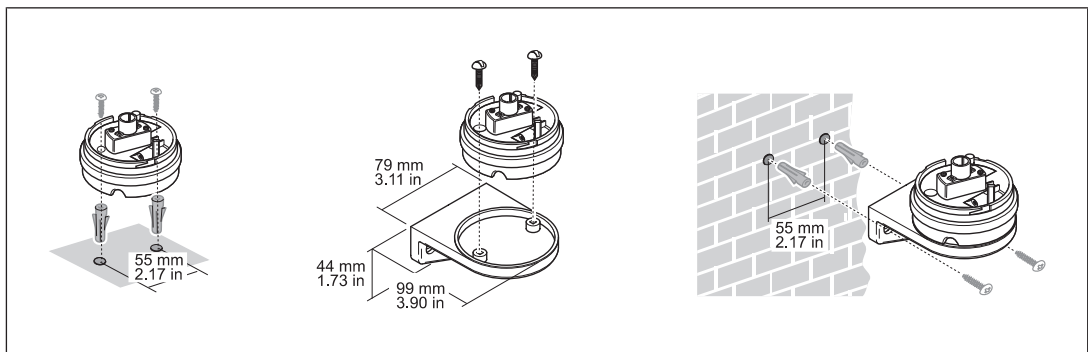

Fig.: Installation

- ▶ Refit the bulb and the cover. To ensure that no dirt enters the housing, the cover must be securely locked to the base. Rotate the cover to the left until the lug on the cover engages behind the lug on the base.

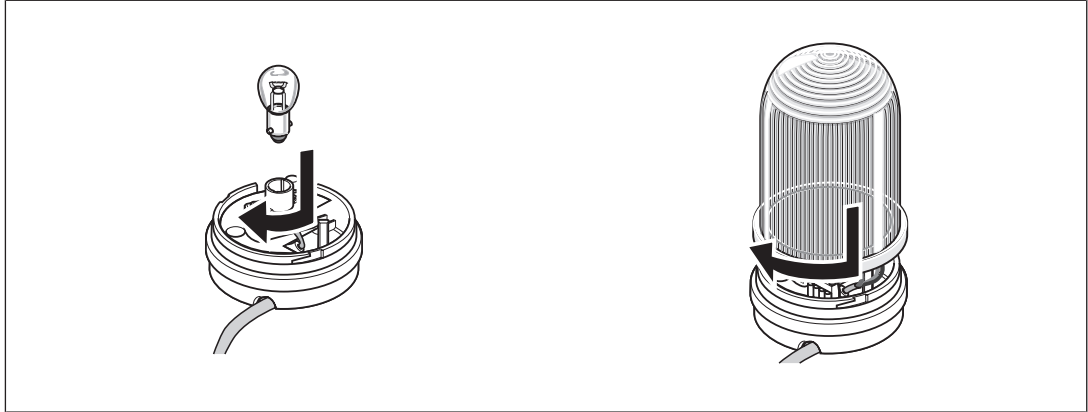

Fig.: Fit the bulb and lock the cover

If it is necessary to open the cover again, e.g. to replace the bulb, press down the strip underneath the lug using a screwdriver. In this way the cover is unlocked and can be opened by rotating.

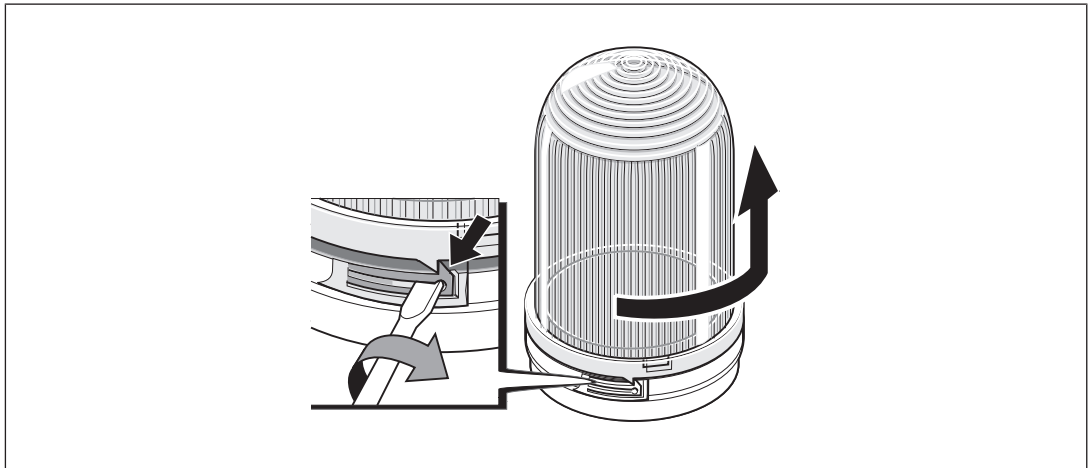

Fig.: Re-open cover

Connection examples

Application examples for use with the PMUT X1P muting controller are described in the related operating manual.

Driven via PNOZmulti

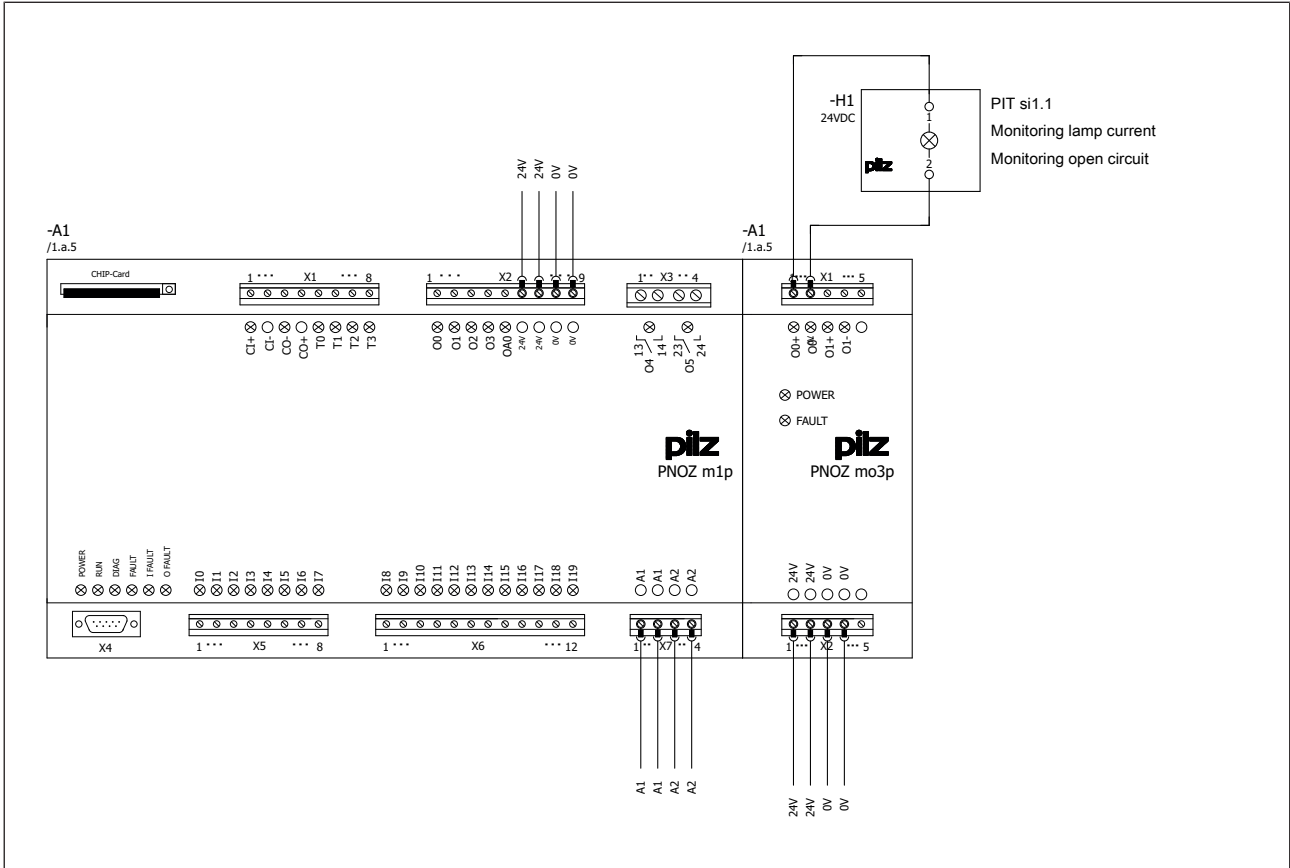

Fig.: Driven via PNOZ m1p with PNOZ mo3p

Driven via PSSuniversal

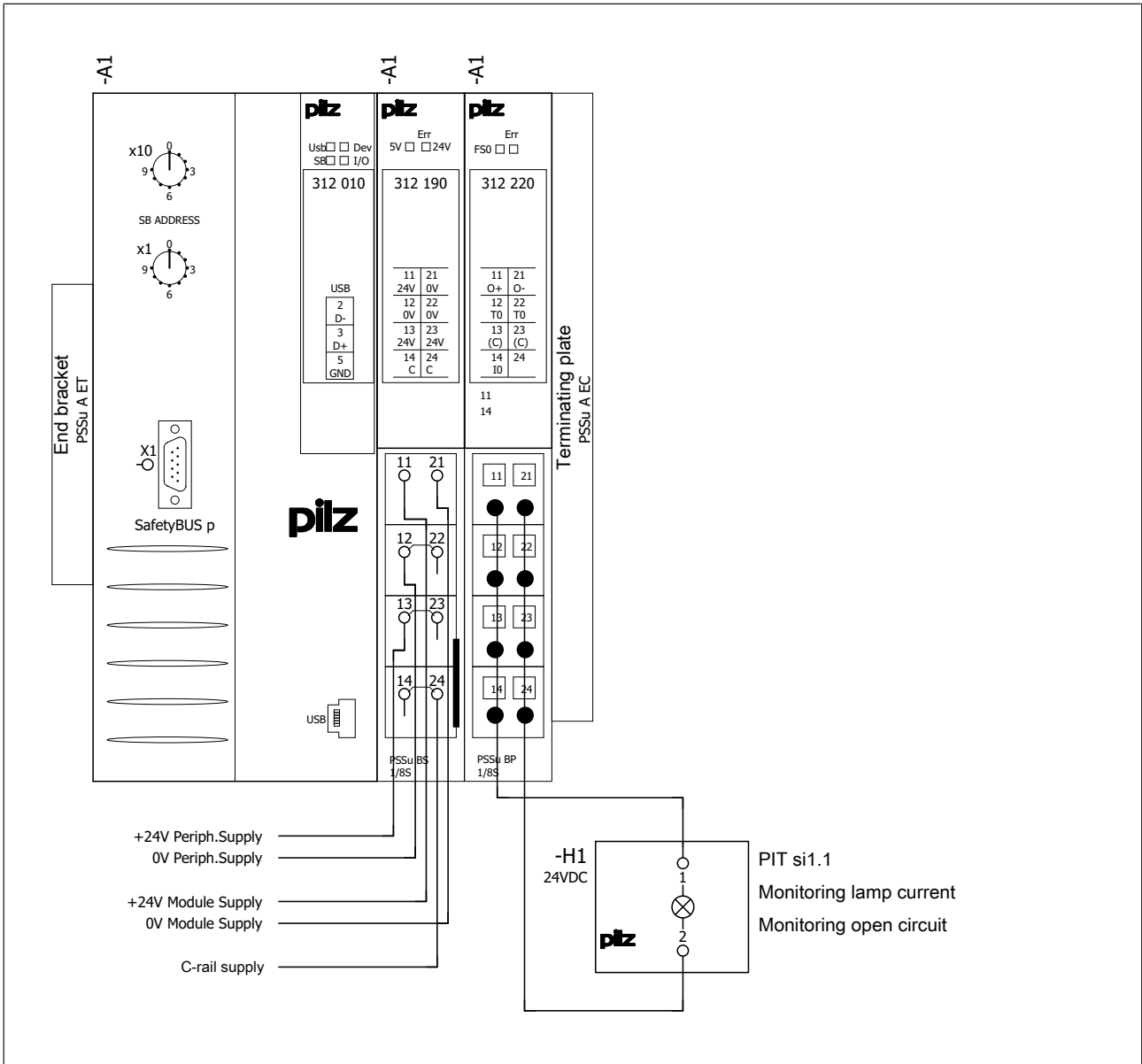

Fig.: Driven via PSSu H SB with PSSu E F PS and PSSu E F DI OZ 2

Dimensions

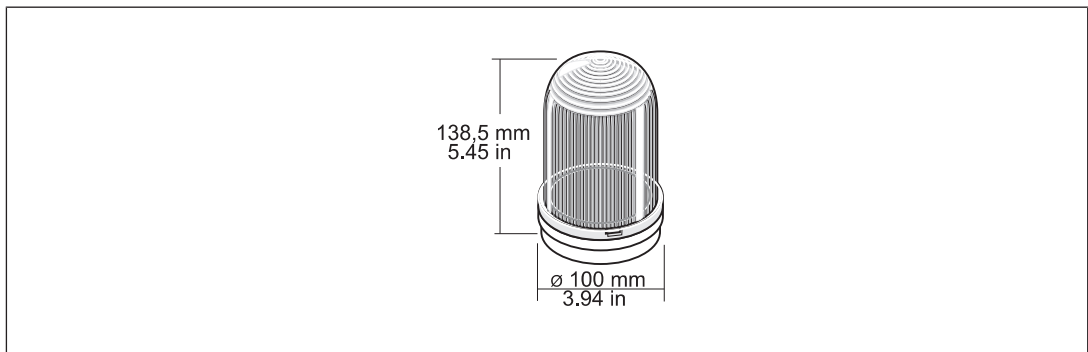

Fig.: Dimensions

Technical details

General	
Certifications	CE, UKCA, cULus Listed
Self-monitored	No
Lamp	
Kind	Bulb
Type	BA15d, 24 V DC, 5W
Electrical life	1,000 hours
Electrical data	
Supply voltage	
Voltage	24 V
Kind	DC
Voltage tolerance	-15 %/+15 %
Output of external power supply (DC)	5 W
Duty cycle	100 %
Environmental data	
Ambient temperature	
Temperature range	-25 - 50 °C
Storage temperature	
Temperature range	-25 - 50 °C
Protection type	
Housing	IP65
Mechanical data	
Cable diameter	5 - 8 mm
Cable gland	ISO 20 mm
Mounting position	Any
Material	
Cover	PC
Bottom	ABS
Connection type	Spring-loaded terminal
Conductor cross section with spring-loaded terminals: Flexible with/without crimp connector	0,75 - 1,5 mm ²
Dimensions	
Height	138,5 mm
Diameter of pushbutton	100 mm
Weight	255 g

Order reference

Product type	Features	Order no.
PIT si1.1 muting lamp	Signal lamp for muting operation	620010

► Support

Technical support is available from Pilz round the clock.

Americas

Brazil

+55 11 97569-2804

Canada

+1 888 315 7459

Mexico

+52 55 5572 1300

USA (toll-free)

+1 877-PILZUSA (745-9872)

Asia

China

+86 21 60880878-216

Japan

+81 45 471-2281

South Korea

+82 31 778 3300

Australia and Oceania

Australia

+61 3 95600621

New Zealand

+64 9 6345350

Europe

Austria

+43 1 7986263-0

Belgium, Luxembourg

+32 9 3217570

France

+33 3 88104003

Germany

+49 711 3409-444

Ireland

+353 21 4804983

Italy, Malta

+39 0362 1826711

Scandinavia

+45 74436332

Spain

+34 938497433

Switzerland

+41 62 88979-32

The Netherlands

+31 347 320477

Turkey

+90 216 5775552

United Kingdom

+44 1536 462203

You can reach our international hotline on:

+49 711 3409-222

support@pilz.com

Pilz develops environmentally-friendly products using ecological materials and energy-saving technologies. Offices and production facilities are ecologically designed, environmentally-aware and energy-saving. So Pilz offers sustainability, plus the security of using energy-efficient products and environmentally-friendly solutions.



We are represented internationally. Please refer to our homepage www.pilz.com for further details or contact our headquarters.

Headquarters: Pilz GmbH & Co. KG, Felix-Wankel-Straße 2, 73760 Ostfildern, Germany
Telephone: +49 711 3409-0, Telefax: +49 711 3409-133, E-Mail: info@pilz.com, Internet: www.pilz.com

PILZ
THE SPIRIT OF SAFETY

21040-EN-04, 2023-03 Printed in Germany
© Pilz GmbH & Co. KG, 2019

CECE®, CHRE®, CMSE®, InduraNET p®, Leansafe®, Master of Safety®, Master of Security®, PAS4000®, PAScall®, PASconfig®, Pilz®, PTT®, PLID®, PMCPirimo®, PMCPiritego®, PMCTendo®, PMD®, PMJ®, PNOZ®, PRBM®, PRCM®, PRIMO®, PRM®, PSENET p®, PSEN®, PSS®, PVS®, SafetyBUS p®, SafetyEYE®, SafetyNET p®, THE SPIRIT OF SAFETY® are registered and protected trademarks of Pilz GmbH & Co. KG in some countries. We would point out that product features may vary from the details stated in this document, depending on the status at the time of publication and the scope of the equipment. We accept no responsibility for the validity, accuracy and entirety of the text and graphics presented in this information. Please contact our Technical Support if you have any questions.