



► PMUT X1P

PILZ
THE SPIRIT OF SAFETY

Operating Manual-20587-EN-09
- Safe monitoring relays



This document is the original document.

Where unavoidable, for reasons of readability, the masculine form has been selected when formulating this document. We do assure you that all persons are regarded without discrimination and on an equal basis.

All rights to this documentation are reserved by Pilz GmbH & Co. KG. Copies may be made for the user's internal purposes. Suggestions and comments for improving this documentation will be gratefully received.

Pilz®, PIT®, PMI®, PNOZ®, Primo®, PSEN®, PSS®, PVIS®, SafetyBUS p®, SafetyEYE®, SafetyNET p®, the spirit of safety® are registered and protected trademarks of Pilz GmbH & Co. KG in some countries.



SD means Secure Digital

Introduction	5
Validity of documentation	5
Using the documentation	5
Definition of symbols	5
Safety	6
Intended use	6
Safety regulations	6
Safety assessment	6
Use of qualified personnel	7
Warranty and liability	7
Disposal	7
For your safety	7
Unit features	8
Safety features	8
Block diagram/terminal configuration	9
Function description	9
Timing diagram	10
Operating modes	11
Muting	11
Reset input	13
Additional inputs for light guard or safety contacts	13
Muting lamps	13
Installation	14
Wiring	15
Preparing for operation	16
Application example	18
Operation	18
Status indicators	19
Fault indicators	19
Faults – Interference	20
Dimensions in mm	20
Technical details	21
Safety characteristic data	27
Supplementary data	28
Service life graph	28

Order reference	29
EC declaration of conformity	29
UKCA-Declaration of Conformity	29

Introduction

Validity of documentation

This documentation is valid for the product PMUT X1P. It is valid until new documentation is published.

This operating manual explains the function and operation, describes the installation and provides guidelines on how to connect the product.

Using the documentation

This document is intended for instruction. Only install and commission the product if you have read and understood this document. The document should be retained for future reference.

Definition of symbols

Information that is particularly important is identified as follows:



DANGER!

This warning must be heeded! It warns of a hazardous situation that poses an immediate threat of serious injury and death and indicates preventive measures that can be taken.



WARNING!

This warning must be heeded! It warns of a hazardous situation that could lead to serious injury and death and indicates preventive measures that can be taken.



CAUTION!

This refers to a hazard that can lead to a less serious or minor injury plus material damage, and also provides information on preventive measures that can be taken.



NOTICE

This describes a situation in which the product or devices could be damaged and also provides information on preventive measures that can be taken. It also highlights areas within the text that are of particular importance.

**INFORMATION**

This gives advice on applications and provides information on special features.

Safety**Intended use**

The muting controller meets the requirements of EN 60204-1.

It may be used in safety circuits for the temporary suspension of safety functions (muting) in accordance with EN 61496-1.

The muting controller may only be used with a type 4 light guard.

Improper use

The following is deemed improper use in particular:

- ▶ Any component, technical or electrical modification to the product,
- ▶ Use of the product outside the areas described in this operating manual,
- ▶ Use of the product outside the technical details (see chapter entitled [Technical Details](#) [📖 21]).

**NOTICE****EMC-compliant electrical installation**

The product is designed for use in an industrial environment. The product may cause interference if installed in other environments. If installed in other environments, measures should be taken to comply with the applicable standards and directives for the respective installation site with regard to interference.

Safety regulations**Safety assessment**

Before using a device, a safety assessment in accordance with the Machinery Directive is required.

The product as an individual component fulfils the functional safety requirements in accordance with EN ISO 13849 and EN IEC 62061. However, this does not guarantee the functional safety of the overall plant/machine. To achieve the relevant safety level of the overall plant/machine's required safety functions, each safety function needs to be considered separately.

Use of qualified personnel

The products may only be assembled, installed, programmed, commissioned, operated, maintained and decommissioned by persons who are competent to do so.

A competent person is a qualified and knowledgeable person who, because of their training, experience and current professional activity, has the specialist knowledge required. To be able to inspect, assess and operate devices, systems and machines, the person has to be informed of the state of the art and the applicable national, European and international laws, directives and standards.

It is the company's responsibility only to employ personnel who

- ▶ Are familiar with the basic regulations concerning health and safety / accident prevention,
- ▶ Have read and understood the information provided in the section entitled Safety
- ▶ Have a good knowledge of the generic and specialist standards applicable to the specific application.

Warranty and liability

All claims to warranty and liability will be rendered invalid if

- ▶ The product was used contrary to the purpose for which it is intended,
- ▶ Damage can be attributed to not having followed the guidelines in the manual,
- ▶ Operating personnel are not suitably qualified,
- ▶ Any type of modification has been made (e.g. exchanging components on the PCB boards, soldering work etc.).

Disposal

- ▶ In safety-related applications, please comply with the mission time T_M in the safety-related characteristic data.
- ▶ When decommissioning, please comply with local regulations regarding the disposal of electronic devices (e.g. Electrical and Electronic Equipment Act).

For your safety

The unit meets all the necessary conditions for safe operation. However, please note the following:

- ▶ Note for overvoltage category III: If voltages higher than low voltage (>50 VAC or >120 VDC) are present on the unit, connected control elements and sensors must have a rated insulation voltage of at least 250 V.

Unit features

- ▶ Positive-guided relay outputs:
 - 3 safety contacts (N/O), instantaneous
 - 1 auxiliary contact (N/C), instantaneous
- ▶ 4 inputs for muting sensors
- ▶ 1 ESPE input for light grids (2-channel, contact or semiconductor outputs)
- ▶ 1 input for additional safety light grid (2-channel, contact outputs) or safety contacts
- ▶ Connection option for 2 muting lamps
- ▶ Connection options for:
 - Start button
 - Key switch
 - Feedback loop
- ▶ 5 semiconductor outputs
- ▶ Monitors muting lamps
- ▶ Muting mode: sequential or parallel
- ▶ LED display for:
 - Switch status channel 1/2
 - Muting sensors
 - Light grid
 - Simultaneity requirement
 - Muting lamp error
- ▶ Semiconductor outputs signal:
 - Switch state of the safety contacts
 - Muting active
 - One of the muting lamps defective
 - Both muting lamps defective
 - Light grid (ESPE) active
- ▶ Plug-in connection terminals (either spring-loaded terminal or screw terminal)
- ▶ See order reference for unit types

Safety features

The safety relay meets the following safety requirements:

- ▶ The circuit is redundant with built-in self-monitoring.
- ▶ The safety function remains effective in the case of a component failure.
- ▶ The correct opening and closing of the safety function relays is tested automatically in each on-off cycle.

Block diagram/terminal configuration

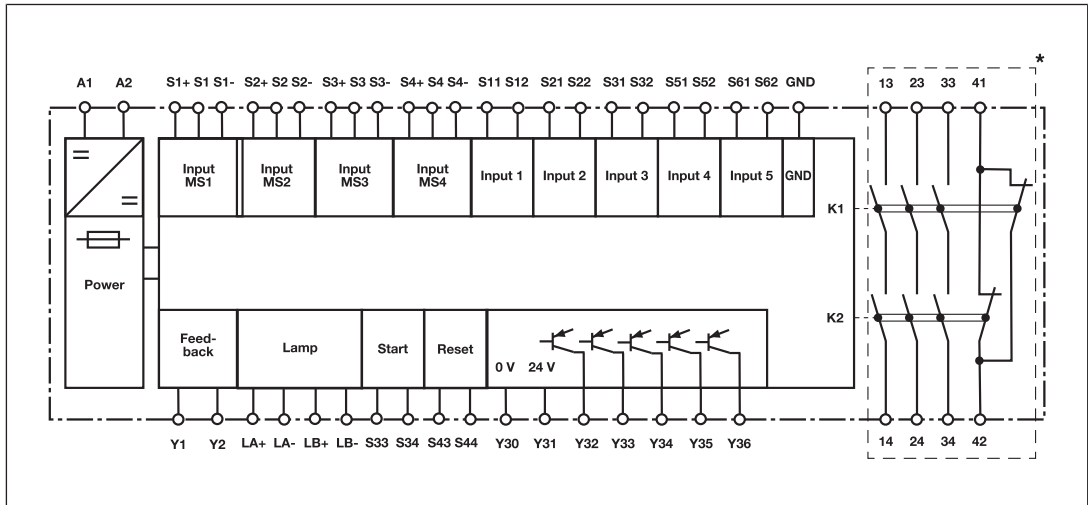

*Insulation between the non-marked area and the relay contacts: Basic insulation (over-voltage category III), Protective separation (overvoltage category II)

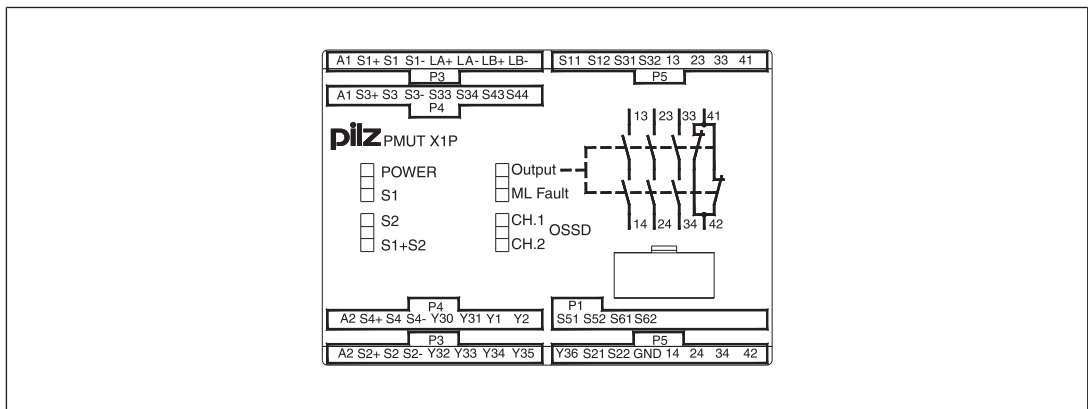

Function description

The muting controller PMUT X1P is used for the temporary suspension of safety functions. This allows objects to be transported into and out of a danger zone without adversely affecting the safety function. When the supply voltage is applied the "POWER" LED will light. The unit is ready for operation when the feedback loop Y1-Y2 and the input circuit (e.g. light guard at S12 and S22 not interrupted) are closed. The muting sensors are not active.

- ▶ Start circuit S33-S34 is closed:
 - Safety contacts 13-14/23-24/33-34 are closed, auxiliary contact 41-42 is open.
 - Status indicators "Output", "OSSD CH.1" and "OSSD CH.2" are lit.
 - A high signal is present at the semiconductor output Y32 (ESPE state).
 - A high signal is present at the semiconductor output Y36 (switch state of safety contacts)
- ▶ Input circuit is opened (e.g. light guard at S12 and S22 interrupted):
 - Safety contacts 13-14/23-24/33-34 are opened redundantly, auxiliary contact 41-42 is closed.

- Status indicators "Output", "OSSD CH.1" and "OSSD CH.2" go out.
- A low signal is present at the semiconductor output Y36 (switch state of safety contacts).
- A low signal is present at semiconductor output Y32 (ESPE state).

Timing diagram

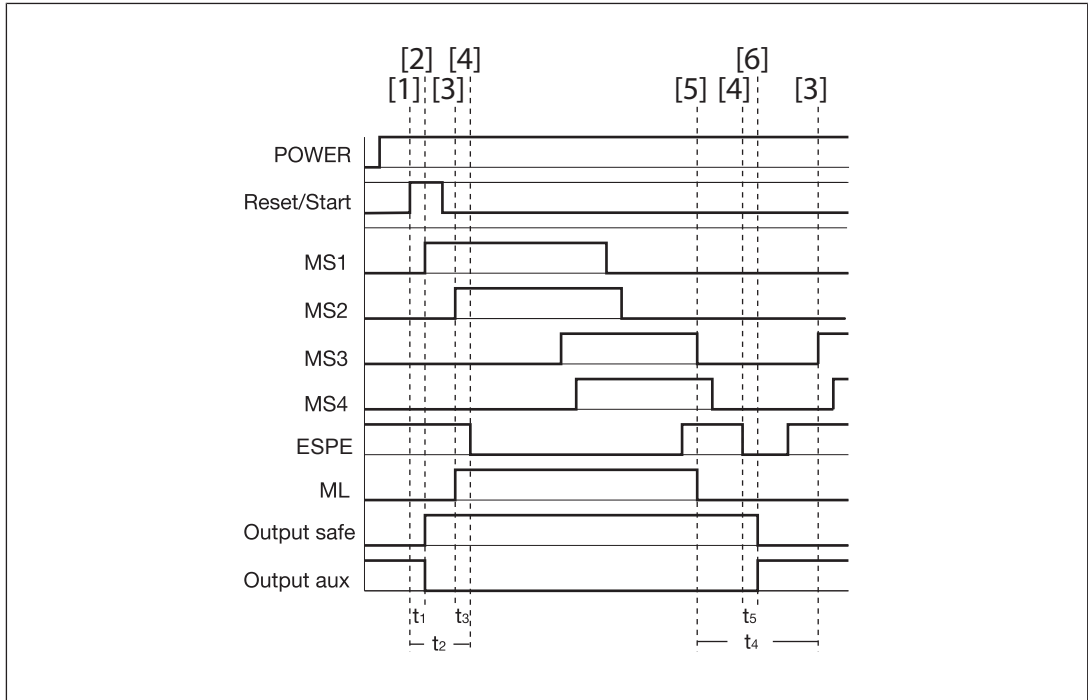

Legend

- ▶ Power: Supply voltage
- ▶ Start: Start button
- ▶ ESPE: Light curtain
- ▶ MS1 ... MS4: Muting sensors
- ▶ ML: Muting lamps
- ▶ Output Safe: Safety contacts 13-14, 23-24, 33-34
- ▶ Output aux: Auxiliary contact 41-42
- ▶ [1]: Press start button
- ▶ [2]: Close safety contacts
- ▶ [3]: Muting on
- ▶ [4]: Light curtain interrupted
- ▶ [5]: Muting off
- ▶ [6]: Open safety contacts
- ▶ t_1 : Switch-on delay safety contacts
- ▶ t_2 : Minimum start pulse duration
- ▶ t_3 : Max. switch-on delay muting
- ▶ t_4 : Recovery time after muting off
- ▶ t_5 : Delay-on de-energisation

Operating modes

- ▶ Dual-channel operation (contact or semiconductor outputs from ESPE) without detection of shorts across contacts
- ▶ Dual-channel operation (contact or semiconductor outputs from ESPE) with detection of shorts across contacts: redundant input circuit, earth faults in the input circuit or shorts across the input circuits are detected.
- ▶ Monitored manual start: The supply voltage must be present and the safety circuits closed before the start contact is closed. The unit is not active until the start button has been operated once the waiting period has expired (see technical details).



WARNING!

Muting start despite triggered safety function

When the Muting function is started even though the protected field of the light guard, for example, is interrupted by a person, the machine/plant will start up again and this may lead to serious injury and death.

Before you start the Muting function, the protected field has to be free and the OSSD have to be in OFF state. The start has to be triggered manually by the operator.

Muting

The muting controller can be used for parallel or sequential muting:

- ▶ Parallel muting with 2 muting sensors

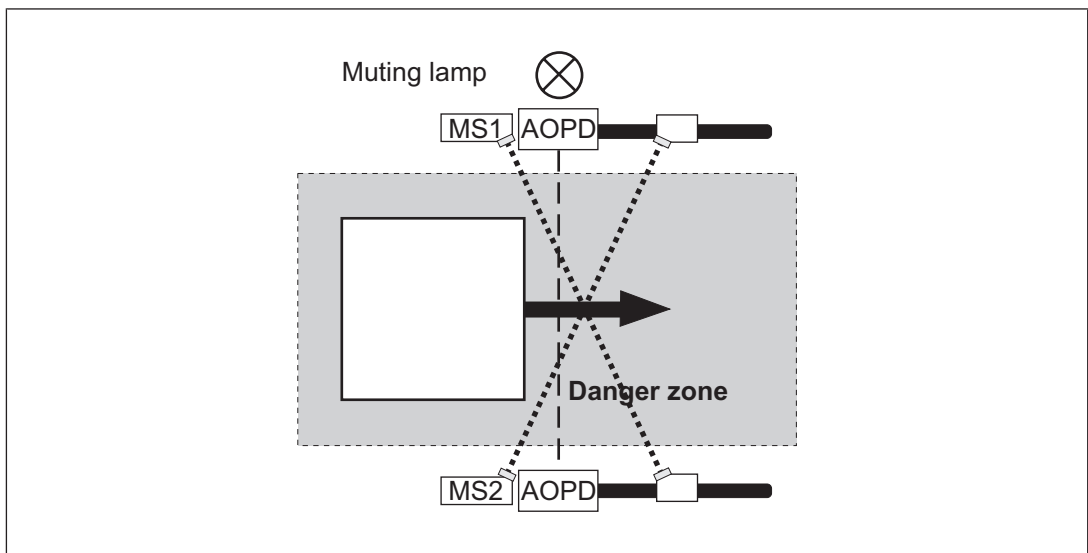

- ▶ Parallel muting with 4 muting sensors

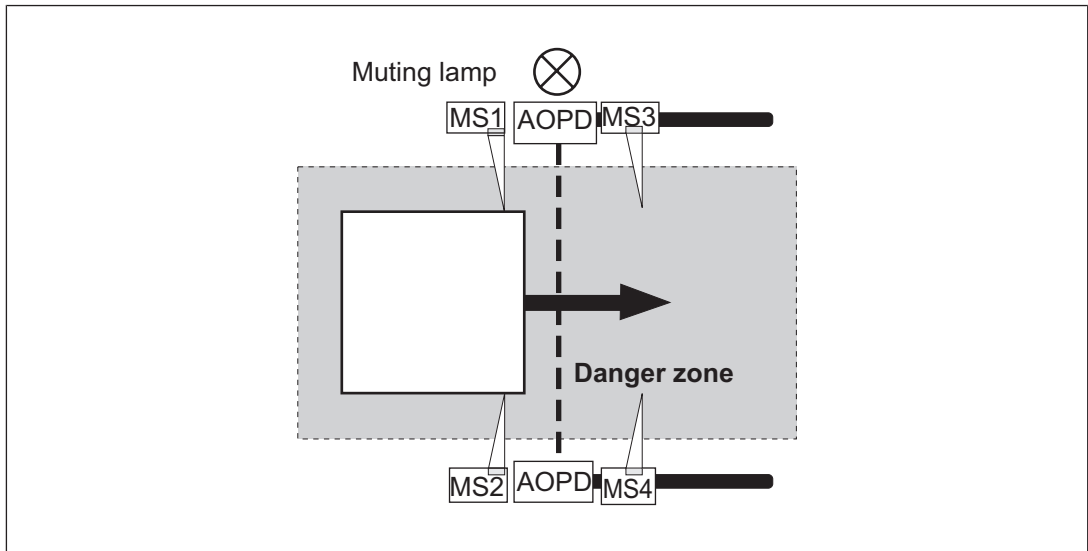

► Sequential muting with 4 muting sensors

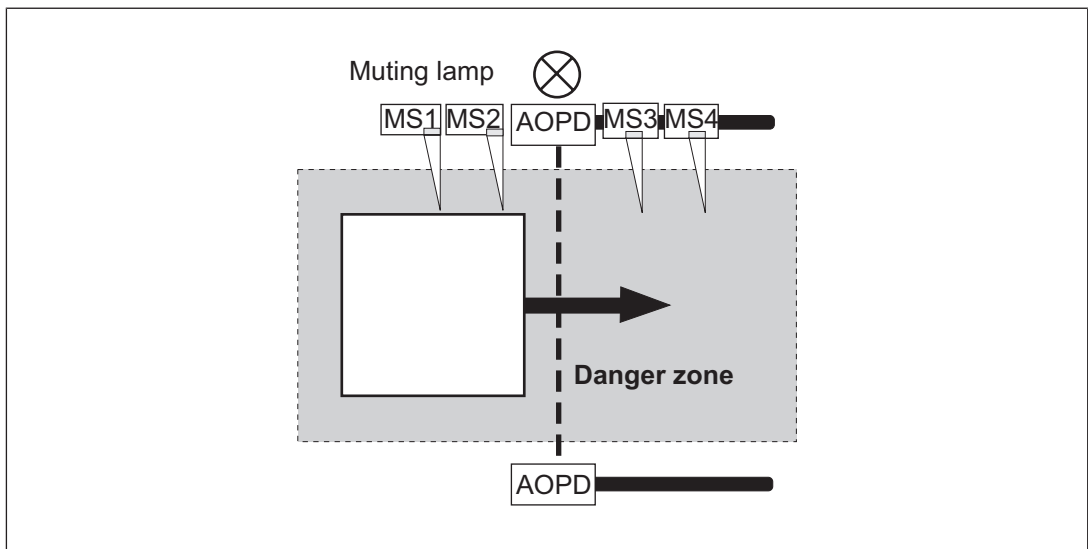

Muting sensors MS1 and MS2 must energise within 3 s (simultaneity). Muting starts when both muting sensors are active. The inputs of light guards S11-S12, S21-S22 and S31-S32 are muted. Status indicators "S1+S2" (Muting active), "S1", "S2" "OSSD CH.1" and "OSSD CH.2" are lit. A high signal is present at semiconductor output Y32 (muting active).

If the light guards are interrupted (inputs S12 and S22 not active), status indicators "OSSD CH.1" and "OSSD CH.2" will go out. A low signal is present at semiconductor output Y32 (ESPE state). Muting sensors MS3 and MS4 must energise while MS1 and MS2 are still active. Only then may MS1 and MS2 become inactive. The muting cycle will then continue. Muting is ended when one muting sensor at most (MS3 or MS4) is active.

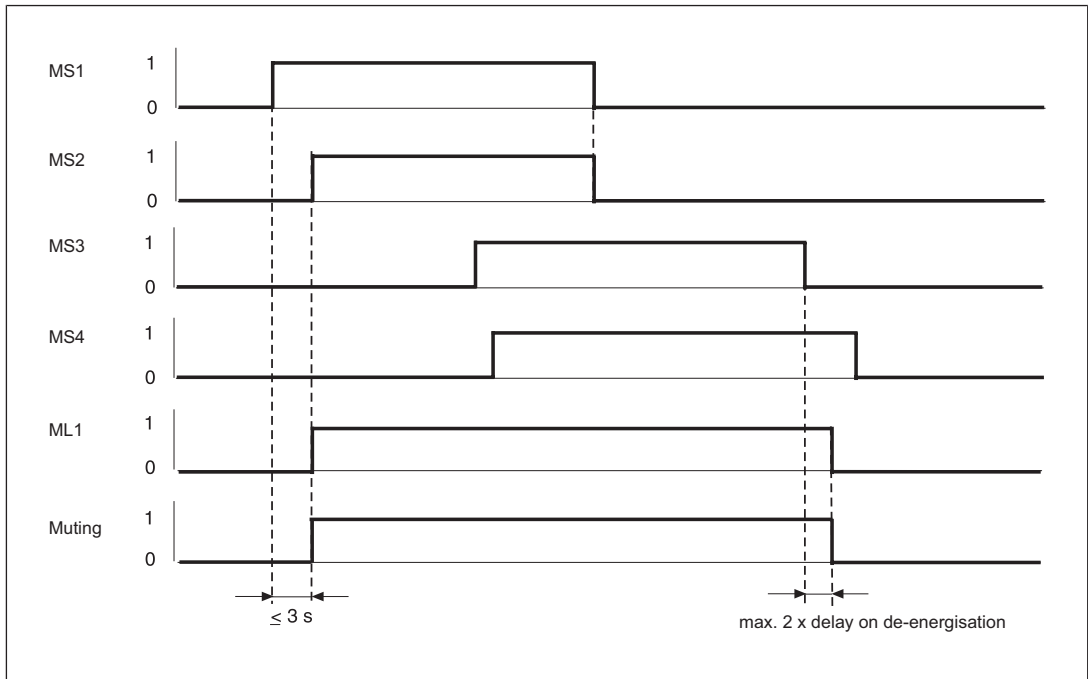

Legend:

- MS1: Muting sensor 1
- MS2: Muting sensor 2
- MS3: Muting sensor 3
- MS4: Muting sensor 4
- ML1: Muting lamp 1

Reset input

If the simultaneity requirement of 3 s is exceeded, the unit will go to a fault condition. Once the fault has been rectified, the simultaneity must be reset by operating the key switch at S43-S44. The start button S33-34 must then be operated. The muting controller is ready for operation.

Additional inputs for light guard or safety contacts

Additional safety contacts can be connected to the muting controller at S51-S52 and S61-S62 (e.g. a dual-channel safety light guard with safe output contacts). These input circuits can monitor the muted ESPE. However, these inputs do not have a muting function. If the contacts connected at S51-S52 and S61-S62 are interrupted, safety contacts 13-14/23-24/33-34 are opened redundantly, auxiliary contact 41-42 is closed. Status indicator "Output" goes out. A low signal is present at semiconductor output Y36.

Muting lamps

The muting controller PMUT X1P is designed for use with one or two muting lamps. As soon as the inputs of the light guard are muted, the Muting lamp ML1 will light. The PMUT X1P monitors the connected muting lamps during the muting cycle. If muting lamp ML1 is defective (e.g. coiled filament broken or lamp switched off), then the PMUT X1P automatically switches to muting lamp ML2. A high signal is present at semiconductor output Y34 (muting lamp 1 defective). If muting lamp ML2 is defective or is not connected, a high signal

is present at semiconductor output Y35 (both muting lamps defective). The "ML Fault" LED is lit. If the light guards (ESPE) are interrupted when the muting lamps are defective, then safety contacts 13-14/23-24/33-34 are opened redundantly, auxiliary contact 41-42 is closed. Status indicators "Output", "OSSD CH.1" and "OSSD CH.2" go out.

**NOTICE**

Only use muting lamps that switch themselves off if there is a defect.

Installation

- ▶ The unit should be installed in a control cabinet with a protection type of at least IP54.
- ▶ Use the notch on the rear of the unit to attach it to a DIN rail (35 mm).
- ▶ When installed vertically: Secure the unit by using a fixing element (e.g. retaining bracket or end angle).
- ▶ When installing the light guards (muting sensors, ESPE), it is essential that the respective standards and regulations are observed. If you are using reflective light barriers (parallel muting with 2 muting sensors), the light beams must cross within the danger zone.
- ▶ The start button has to be installed in such a way that the operator can see into the danger zone when operating the start button.

Wiring

Please note:

- ▶ Information given in the "[Technical details \[📖 21\]](#)" must be followed.
- ▶ Outputs 13-14, 23-24, 33-34 are safety contacts; output 41-42 is an auxiliary contact (e.g. for display).
- ▶ Auxiliary contact 41-42 should **not** be used for safety circuits!
- ▶ Semiconductor outputs should **not** be used for safety circuits!
- ▶ Delivery status: S51-S52/S61-S62/Y1-Y2/S31-S32 are linked
- ▶ To prevent contact welding, a fuse should be connected before the output contacts (see [Technical details \[📖 21\]](#)).
- ▶ Calculation of the max. cable length l_{\max} in the input circuit:

$$l_{\max} = \frac{R_{l_{\max}}}{R_l / \text{km}}$$

$R_{l_{\max}}$ = max. overall cable resistance (see [Technical details \[📖 21\]](#))

R_l / km = cable resistance/km

- ▶ Use copper wiring with a temperature stability of 60/75 °C.
- ▶ To prevent EMC interferences (particularly common-mode interferences) the measures described in EN 60204-1 must be executed. This includes the separate routing of cables of the control circuits (input, start and feedback loop) from other cables for energy transmission or the shielding of cables, for example.
- ▶ Adequate protection must be provided on all output contacts with capacitive and inductive loads.
- ▶ Do not switch low currents using contacts that have been used previously with high currents.
- ▶ Mechanical and optoelectronic sensors (safety light beam devices, safety light grids) are suitable for use.
- ▶ The safety contacts can be used to shut down the potentially hazardous movement.
- ▶ Only safe contact outputs (e.g. from safety light grids) may be used at S51-S52 and S61-S62. Do **not** connect safety light grids with semiconductor outputs.
- ▶ The cables for connecting the muting sensors to terminals S1/S3 and S2/S4 must be laid in separate sheathed cables!
- ▶ Only use muting lamps that have a luminous area of at least 1cm² and a luminosity of at least 200 cd/m², in accordance with EN 61496-1.
- ▶ When connecting magnetically operated, reed proximity switches, ensure that the max. peak inrush current (on the input circuit) does not overload the proximity switch.

Preparing for operation

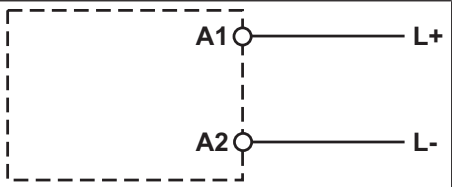
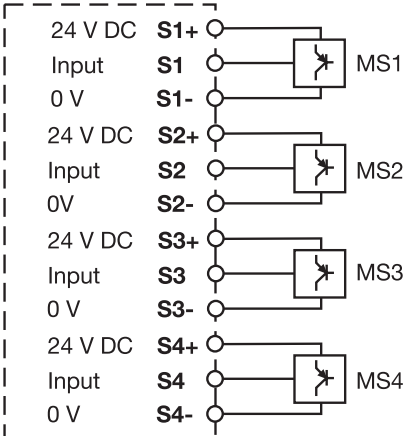
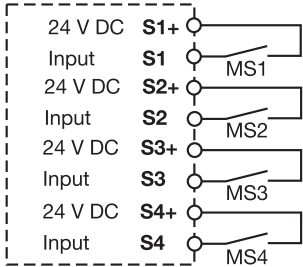
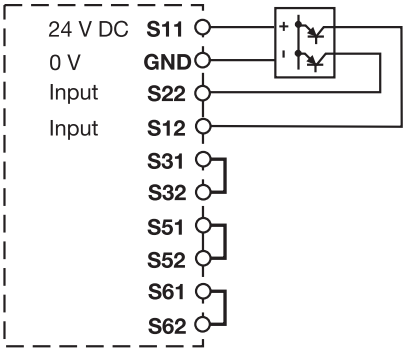
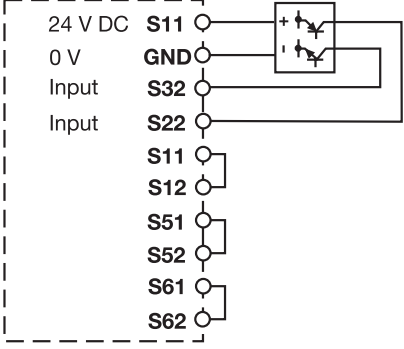
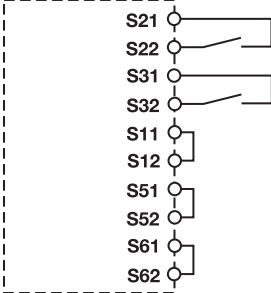
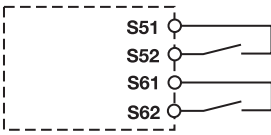
Supply voltage	AC	DC
	/	
Input circuit	Semiconductor	Contacts
Muting sensors		
Light grid (ESPE) Semiconductor output 2 x PNP Detection of shorts across con- tacts via light grid		/
Light grid (ESPE) Semiconductor output PNP/NPN Detection of shorts across con- tacts; - Semiconductor: via light grid - Contacts: via PMUT X1P		
Additional light grid, 2-channel, E- STOP pushbutton	/	



NOTICE

Shorts across contacts must be detected in order to achieve PL e of EN ISO 13849-1. The independence of both ESPE channels is either monitored through the light grid itself or through the muting controller.



INFORMATION

If you are only using 2 muting sensors, connect these to S1, S1+, S2- and S2, S2+, S2-.

Muting lamp	
Start circuit	
S1: Key switch S3: Start button	



NOTICE

The path of the ESPE light beam must be clear when the PMUT X1P muting controller is started through operation of the start button. Only then is the muting controller ready for operation.

Feedback loop	without feedback loop monitoring	with feedback loop monitoring
Link or contacts from external contactors		

Semiconductor output	
Y32: Light grid active Y33: Muting active Y34: Muting lamp warning Y35: Both muting lamps defective Y36: Safety contacts closed	

Application example

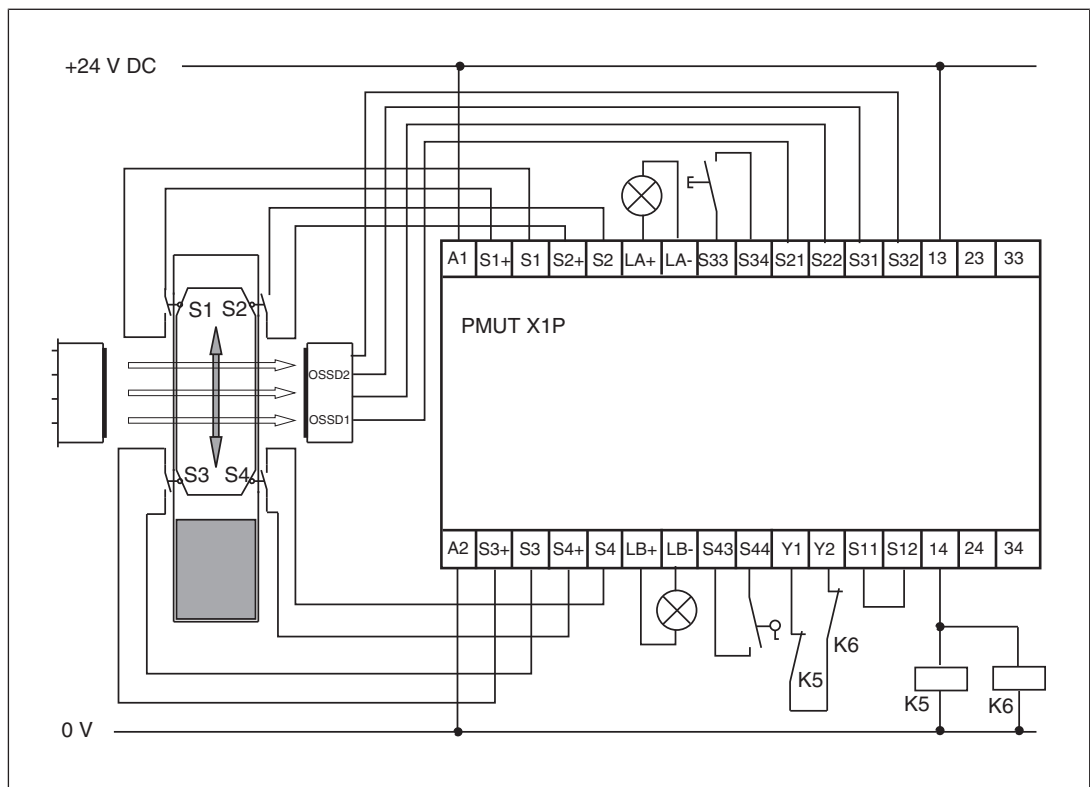

Operation

When the relay outputs are switched on, the mechanical contact on the relay cannot be tested automatically. Depending on the operational environment, measures to detect the non-opening of switching elements may be required under some circumstances.

When the product is used in accordance with the European Machinery Directive, a check must be carried out to ensure that the safety contacts on the relay outputs open correctly. Open the safety contacts (switch off output) and start the device again, so that the internal diagnostics can check that the safety contacts open correctly

- ▶ for SIL 3/PL e at least 1x per month
- ▶ for SIL 2/PL d at least 1x per year



NOTICE

The safety functions should be checked after initial commissioning and each time the plant/machine is changed. The safety functions may only be checked by qualified personnel.

LEDs indicate the status and errors during operation:

- LED on
- LED off

Status indicators

- POWER**
Supply voltage is present.
- S1**
Muting sensor MS1 and/or MS3 active.
- S2**
Muting sensor MS2 and/or MS4 active.
- S1+S2**
Muting active.
- OUTPUT**
Safety contacts are closed and auxiliary contact is open.
- CH.1**
Light grid channel 1 active.
- CH.2**
Light grid channel 2 active.

Fault indicators

- POWER**
Short circuit or no supply voltage
- ML FAULT**
Diagnostics: Both muting lamps are defective.
▶ Remedy: Test and replace muting lamps.
- S1+S2** **S1, S2**
Diagnostics: The simultaneity requirement ≤ 3 s has been exceeded.
▶ Remedy: Check the position of the muting sensors.

Faults – Interference

- ▶ Failure of the supply voltage during the muting cycle or simultaneity time is exceeded: Operation of the key switch resets the simultaneity requirement. The muting cycle is re-started.
- ▶ High signal at semiconductor output Y34 (muting lamp 1 defective): Switching from muting lamp ML1 to muting lamp ML2 during muting may cause the safety contacts to latch. In this case it will no longer be possible to start the PMUT X1P simply by operating the key switch. Alternatively, follow the instructions below:
 - Operate key switch and interrupt ESPE
 - or
 - Operate additional safety contact at S51-S52 or S61-S62
 - or
 - Disconnect the unit from the supply.

To guarantee the availability of the muting controller, change the defective muting lamp ML1 as quickly as possible.

- ▶ Earth fault S43, S33, S34, Y1, Y2, S11, S12 to GND: the supply voltage fails and the safety contacts open. Once the cause of the fault has been removed and supply voltage is maintained, the unit will be ready for operation after approximately 5 s.
- ▶ Contact malfunctions: If the contacts have welded, reactivation will not be possible after the input circuit has opened.

Dimensions in mm

* With spring-loaded terminals

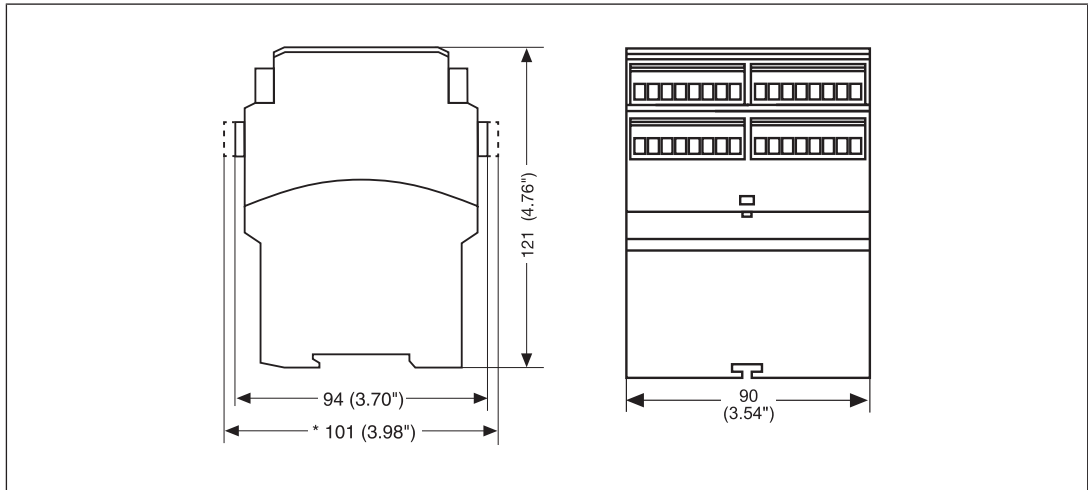

Technical details

General	778010	788010
Certifications	CCC, CE, EAC, TÜV, UKCA, cULus Listed	CCC, CE, EAC, TÜV, UKCA, cULus Listed
Electrical data	778010	788010
Supply voltage		
Voltage	24 V	24 V
Kind	DC	DC
Voltage tolerance	-15 %/+10 %	-15 %/+10 %
Output of external power supply (DC)	33 W	33 W
Power consumption	6 W	6 W
Residual ripple DC	48 %	48 %
Duty cycle	100 %	100 %
Voltage at		
Muting lamp DC	24 V	24 V
Muting lamp LED DC	24 V	24 V
Muting sensor DC	24 V	24 V
Current at		
Muting lamp DC max.	500 mA	500 mA
Muting lamp LED DC min.	40 mA	40 mA
Muting sensor DC	40 mA	40 mA
Connected load min.		
Muting lamp LED	0,96 W	0,96 W
Connected load max.		
Muting sensors	5 W	5 W
Light beam device	10 W	10 W
Muting lamp	12 W	12 W
Inputs	778010	788010
Quantity	9	9
Voltage at		
Input circuit DC	24 V	24 V
Start circuit DC	24 V	24 V
Feedback loop DC	24 V	24 V
Current at		
Input circuit DC	25 mA	25 mA
Start circuit DC	40 mA	40 mA
Feedback loop DC	40 mA	40 mA
Max. inrush current impulse		
Current pulse, input circuit	0,07 A	0,07 A
Min. input resistance at power-on	460 Ohm	460 Ohm

Inputs	778010	788010
Max. overall cable resistance Rl-max		
Dual-channel without detection of shorts across contacts at UB DC	70 Ohm	70 Ohm
Dual-channel with detection of shorts across contacts at UB DC	15 Ohm	15 Ohm
Semiconductor outputs	778010	788010
Quantity	4	4
Voltage	24 V	24 V
Current	20 mA	20 mA
External supply voltage	24 V	24 V
Voltage tolerance	-20 %/+20 %	-20 %/+20 %
Residual current at "0" signal	0,1 mA	0,1 mA
Max. internal voltage drop	4 V	4 V
Conditional rated short circuit current	100 A	100 A
Lowest operating current	0 mA	0 mA
Utilisation category in accordance with EN 60947-1	DC-12	DC-12
Relay outputs	778010	788010
Number of output contacts		
Safety contacts (N/O), instantaneous	3	3
Auxiliary contacts (N/C)	1	1
Max. short circuit current I _K	1 kA	1 kA
Utilisation category in accordance with the standard	EN 60947-4-1	EN 60947-4-1
Utilisation category of safety contacts		
AC1 at	240 V	240 V
Min. current	0,01 A	0,01 A
Max. current	8 A	8 A
Max. power	2000 VA	2000 VA
DC1 at	24 V	24 V
Min. current	0,01 A	0,01 A
Max. current	8 A	8 A
Max. power	200 W	200 W

Relay outputs	778010	788010
Utilisation category of auxiliary con- tacts		
AC1 at	240 V	240 V
Min. current	0,01 A	0,01 A
Max. current	8 A	8 A
Max. power	2000 VA	2000 VA
DC1 at	24 V	24 V
Min. current	0,01 A	0,01 A
Max. current	8 A	8 A
Max. power	200 W	200 W
Utilisation category		
in accordance with the standard	EN 60947-5-1	EN 60947-5-1
Utilisation category of safety con- tacts		
AC15 at	240 V	240 V
Max. current	5 A	5 A
DC13 (6 cycles/min) at	24 V	24 V
Max. current	5 A	5 A
Utilisation category of auxiliary con- tacts		
AC15 at	230 V	230 V
Max. current	5 A	5 A
DC13 (6 cycles/min) at	24 V	24 V
Max. current	5 A	5 A
Utilisation category in accordance with UL		
Voltage	240 V AC G. P.	240 V AC G. P.
with current	8 A	8 A
Voltage	24 V DC Resistive	24 V DC Resistive
with current	5 A	5 A
Pilot Duty	B300, R300	B300, R300
External contact fuse protection, safety contacts		
in accordance with the standard	EN 60947-5-1	EN 60947-5-1
Max. melting integral	240 A²s	240 A²s
Blow-out fuse, quick	10 A	10 A
Blow-out fuse, slow	6 A	6 A
Blow-out fuse, gG	10 A	10 A
Circuit breaker 24V AC/DC, characteristic B/C	6 A	6 A

Relay outputs	778010	788010
External contact fuse protection, auxiliary contacts		
Max. melting integral	240 A²s	240 A²s
Blow-out fuse, quick	10 A	10 A
Blow-out fuse, slow	6 A	6 A
Blow-out fuse, gG	10 A	10 A
Circuit breaker, 24 V AC/DC, characteristic B/C	6 A	6 A
Contact material	AgSnO₂ + 0,2 µm Au	AgSnO₂ + 0,2 µm Au
Conventional thermal current while loading several contacts	778010	788010
I _{th} per contact at UB DC; AC1: 240 V, DC1: 24 V		
Conv. therm. current with 1 contact	8 A	8 A
Conv. therm. current with 2 contacts	6 A	6 A
Conv. therm. current with 3 contacts	5 A	5 A
Times	778010	788010
Switch-on delay		
with monitored start with rising edge typ.	40 ms	40 ms
with monitored start with rising edge max.	80 ms	80 ms
Muting lamp 1 typ.	25 ms	25 ms
Muting lamp 1 max.	30 ms	30 ms
Muting lamp 2	60 ms	60 ms
Muting typ.	35 ms	35 ms
Muting max.	80 ms	80 ms
Delay-on de-energisation		
with E-STOP typ.	8 ms	8 ms
with E-STOP max.	20 ms	20 ms
with power failure typ.	490 ms	490 ms
with power failure max.	700 ms	700 ms
after safety function is triggered typ.	15 ms	15 ms
after safety function is triggered max.	20 ms	20 ms
with power failure during muting typ.	125 ms	125 ms
with power failure during muting max.	180 ms	180 ms
Recovery time at max. switching frequency 1/s		
after E-STOP	320 ms	320 ms
after power failure	1 s	1 s
after muting sensors off	300 ms	300 ms

Times	778010	788010
Waiting period with a monitored start		
with rising edge	300 ms	300 ms
Min. start pulse duration with a monitored start		
with rising edge	40 ms	40 ms
Supply interruption before de-energisation in the input circuit	5 ms	5 ms
Supply interruption before de-energisation	20 ms	20 ms
Simultaneity, channel 1 and 2 max.	3 s	3 s
Environmental data	778010	788010
Climatic suitability	EN 60068-2-78	EN 60068-2-78
Ambient temperature		
Temperature range	-10 - 55 °C	-10 - 55 °C
Storage temperature		
Temperature range	-40 - 85 °C	-40 - 85 °C
Climatic suitability		
Humidity	93 % r. h. at 40 °C	93 % r. h. at 40 °C
Condensation during operation	Not permitted	Not permitted
EMC	EN 61000-6-2, EN 61326-3-1, EN 61496-1	EN 61000-6-2, EN 61326-3-1, EN 61496-1
Vibration		
in accordance with the standard	EN 60068-2-6	EN 60068-2-6
Frequency	10 - 55 Hz	10 - 55 Hz
Amplitude	0,35 mm	0,35 mm
Airgap creepage		
in accordance with the standard	EN 60947-1	EN 60947-1
Overvoltage category	III / II	III / II
Pollution degree	2	2
Rated insulation voltage	250 V	250 V
Rated impulse withstand voltage	4 kV	4 kV
Protection type		
Housing	IP40	IP40
Terminals	IP20	IP20
Mounting area (e.g. control cabinet)	IP54	IP54
Mechanical data	778010	788010
Mounting position	Any	Any
Mechanical life	10,000,000 cycles	10,000,000 cycles
Material		
Bottom	PPO UL 94 V1	PPO UL 94 V1
Front	ABS UL 94 V0	ABS UL 94 V0
Top	PPO UL 94 V1	PPO UL 94 V1
Connection type	Screw terminal	Spring-loaded terminal
Mounting type	plug-in	plug-in

Mechanical data	778010	788010
Conductor cross section with screw terminals		
1 core flexible	0,2 - 2,5 mm², 24 - 12 AWG	–
2 core with the same cross section, flexible with crimp connectors, no plastic sleeve	0,2 - 1 mm², 24 - 16 AWG	–
2 core with the same cross section, flexible without crimp connectors or with TWIN crimp connectors	0,2 - 1,5 mm², 24 - 16 AWG	–
Torque setting with screw terminals	0,5 Nm	–
Stripping length with screw terminals	8 mm	–
Conductor cross section with spring-loaded terminals: Flexible with/without crimp connector	–	0,2 - 1,5 mm², 24 - 16 AWG
Spring-loaded terminals: Terminal points per connection	–	2
Stripping length with spring-loaded terminals	–	8 mm
Dimensions		
Height	94 mm	101 mm
Width	90 mm	90 mm
Depth	121 mm	121 mm
Weight	565 g	565 g

Where standards are undated, the 2022-09 latest editions shall apply.

Safety characteristic data



NOTICE

You must comply with the safety characteristic data in order to achieve the required safety level for your plant/machine.

Operating mode	EN ISO 13849-1: 2015 PL	EN ISO 13849-1: 2015 Category	EN IEC 62061 SIL CL/ maximum SIL	EN IEC 62061 PFH _D [1/h]	EN/IEC 61511 SIL	EN/IEC 61511 PFD	EN ISO 13849-1: 2015 T _M [year]
Muting active	PL e	Cat. 3	SIL 3	8,35E-09	SIL 3	5,54E-04	20
Muting inactive	PL e	Cat. 4	SIL 3	1,45E-09	SIL 3	2,49E-06	20

Explanatory notes for the safety-related characteristic data:

- ▶ Safety characteristic data in accordance with EN IEC 62061 and EN/IEC 61511 was calculated based on EN/IEC 61508.
- ▶ T_M is the maximum mission time in accordance with EN ISO 13849-1. The value also applies as the retest interval in accordance with EN/IEC 61508-6 and EN/IEC 61511 and as the proof test interval and mission time in accordance with EN IEC 62061.

All the units used within a safety function must be considered when calculating the safety characteristic data.



INFORMATION

A safety function's SIL/PL values are **not** identical to the SIL/PL values of the units that are used and may be different. We recommend that you use the PAscal software tool to calculate the safety function's SIL/PL values.

Supplementary data



CAUTION!

It is essential to consider the relay's service life graphs. The relay outputs' safety-related characteristic data is only valid if the values in the service life graphs are met.

The PFH value depends on the switch frequency and the load of the relay output. If the service life graphs are not accessible, the stated PFH value can be used irrespective of the switch frequency and the load, as the PFH value already considers the relay's B10d value as well as the failure rates of the other components.

Service life graph

The service life graphs indicate the number of cycles from which failures due to wear must be expected. The wear is mainly caused by the electrical load; the mechanical load is negligible.

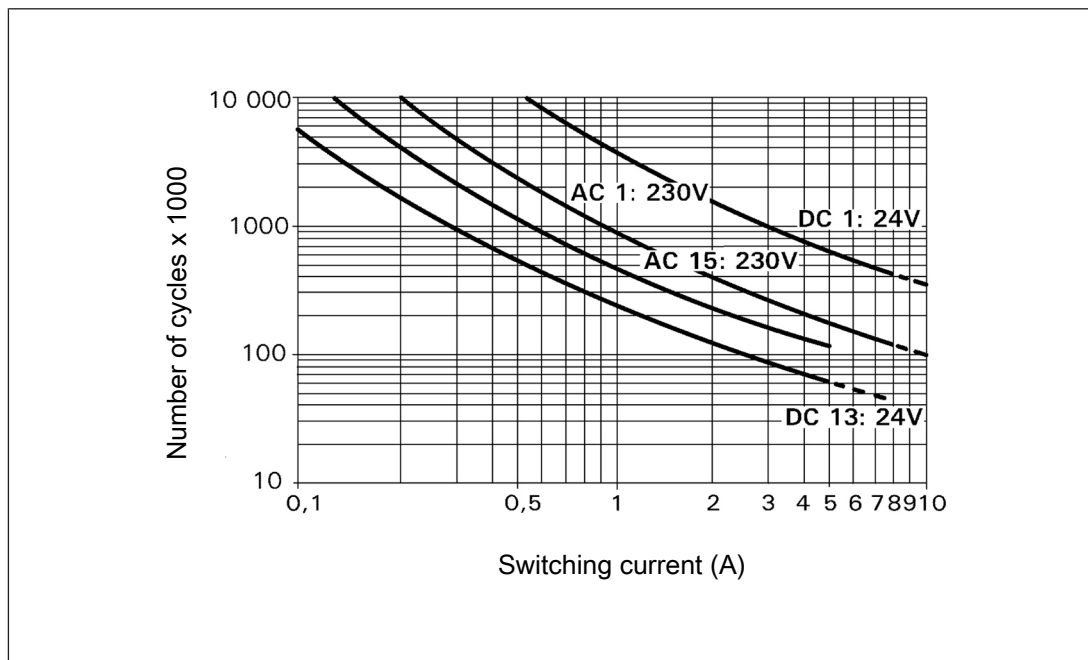

Example

- ▶ Inductive load: 0.2 A
- ▶ Utilisation category: AC15
- ▶ Contact service life: 4 000 000 cycles

Provided the application to be implemented requires fewer than 4 000 000 cycles, the PFH value (see Technical details) can be used in the calculation.

To increase the service life, sufficient spark suppression must be provided on all output contacts. With capacitive loads, any power surges that occur must be noted. With DC contactors, use flywheel diodes for spark suppression.

Order reference

Product type	Features	Connection type	Order no.
PMUT X1P C	24 V DC	Spring-loaded terminals	788010
PMUT X1P	24 V DC	Screw terminals	778010

EC declaration of conformity

This product/these products meet the requirements of the directive 2006/42/EC for machinery of the European Parliament and of the Council. The complete EC Declaration of Conformity is available on the Internet at www.pilz.com/support/downloads.

Representative: Norbert Fröhlich, Pilz GmbH & Co. KG, Felix-Wankel-Str. 2, 73760 Ostfildern, Germany

UKCA-Declaration of Conformity

This product(s) complies with following UK legislation: Supply of Machinery (Safety) Regulation 2008.

The complete UKCA Declaration of Conformity is available on the Internet at www.pilz.com/downloads.

Representative: Pilz Automation Technology, Pilz House, Little Colliers Field, Corby, Northamptonshire, NN18 8TJ United Kingdom, eMail: mail@pilz.co.uk

► Support

Technical support is available from Pilz round the clock.

Americas

Brazil

+55 11 97569-2804

Canada

+1 888 315 7459

Mexico

+52 55 5572 1300

USA (toll-free)

+1 877-PILZUSA (745-9872)

Asia

China

+86 21 60880878-216

Japan

+81 45 471-2281

South Korea

+82 31 778 3300

Australia and Oceania

Australia

+61 3 95600621

New Zealand

+64 9 6345350

Europe

Austria

+43 1 7986263-0

Belgium, Luxembourg

+32 9 3217570

France

+33 3 88104003

Germany

+49 711 3409-444

Ireland

+353 21 4804983

Italy, Malta

+39 0362 1826711

Scandinavia

+45 74436332

Spain

+34 938497433

Switzerland

+41 62 88979-32

The Netherlands

+31 347 320477

Turkey

+90 216 5775552

United Kingdom

+44 1536 462203

You can reach our international hotline on:

+49 711 3409-222

support@pilz.com

Pilz develops environmentally-friendly products using ecological materials and energy-saving technologies. Offices and production facilities are ecologically designed, environmentally-aware and energy-saving. So Pilz offers sustainability, plus the security of using energy-efficient products and environmentally-friendly solutions.



We are represented internationally. Please refer to our homepage www.pilz.com for further details or contact our headquarters.

Headquarters: Pilz GmbH & Co. KG, Felix-Wankel-Straße 2, 73760 Ostfildern, Germany
Telephone: +49 711 3409-0, Telefax: +49 711 3409-133, E-Mail: info@pilz.com, Internet: www.pilz.com

PILZ
THE SPIRIT OF SAFETY

20587-EN-09, 2023-06 Printed in Germany
© Pilz GmbH & Co. KG, 2019

CECE®, CHRE®, CMSE®, InduraNET p®, Leansafe®, Master of Safety®, Master of Security®, PAS4000®, PAScall®, PASconfig®, Pilz®, PTT®, PLID®, PMCPirimo®, PMCPiritego®, PMCTendo®, PMD®, PMJ®, PNOZ®, PRBM®, PRCM®, PRIMO®, PRM®, PSENET p®, PSEN®, PSS®, PVS®, SafetyBUS p®, SafetyEYE®, SafetyNET p®, THE SPIRIT OF SAFETY® are registered and protected trademarks of Pilz GmbH & Co. KG in some countries. We would point out that product features may vary from the details stated in this document, depending on the status at the time of publication and the scope of the equipment. We accept no responsibility for the validity, accuracy and entirety of the text and graphics presented in this information. Please contact our Technical Support if you have any questions.