



Visualisation; Diagnostics

Easy to Configure

Programming IEC 61131-3

Rapid Installation

PNOZ c1

PILZ

THE SPIRIT OF SAFETY

► Safety relays

This document is the original document.

Where unavoidable, for reasons of readability, the masculine form has been selected when formulating this document. We do assure you that all persons are regarded without discrimination and on an equal basis.

All rights to this documentation are reserved by Pilz GmbH & Co. KG. Copies may be made for the user's internal purposes. Suggestions and comments for improving this documentation will be gratefully received.

Pilz®, PIT®, PMI®, PNOZ®, Primo®, PSEN®, PSS®, PVIS®, SafetyBUS p®, SafetyEYE®, SafetyNET p®, the spirit of safety® are registered and protected trademarks of Pilz GmbH & Co. KG in some countries.



SD means Secure Digital

Introduction	5
Validity of documentation	5
Using the documentation	5
Definition of symbols	5
Safety	6
Intended use	6
Safety regulations	6
Safety assessment	6
Use of qualified personnel	6
Warranty and liability	7
Disposal	7
For your safety	7
Unit features	7
Safety features	8
Block diagram/terminal configuration	8
Function description	8
Installation	9
Wiring	9
Connect cable with crimp connector	10
Connect cable without crimp connector	11
Disconnect cable	11
Preparing for operation	12
Operation	13
Status indicators	13
Error indicators	14
Faults - malfunctions	14
Dimensions in mm	14
Technical details	15
Safety characteristic data	19
Supplementary data	19
Service life graph	20

Order reference	21
EC Declaration of Conformity	21
UKCA-Declaration of Conformity	21

Introduction

Validity of documentation

This documentation is valid for the product PNOZ c1. It is valid until new documentation is published.

This operating manual explains the function and operation, describes the installation and provides guidelines on how to connect the product.

Using the documentation

This document is intended for instruction. Only install and commission the product if you have read and understood this document. The document should be retained for future reference.

Definition of symbols

Information that is particularly important is identified as follows:



DANGER!

This warning must be heeded! It warns of a hazardous situation that poses an immediate threat of serious injury and death and indicates preventive measures that can be taken.



WARNING!

This warning must be heeded! It warns of a hazardous situation that could lead to serious injury and death and indicates preventive measures that can be taken.



CAUTION!

This refers to a hazard that can lead to a less serious or minor injury plus material damage, and also provides information on preventive measures that can be taken.



NOTICE

This describes a situation in which the product or devices could be damaged and also provides information on preventive measures that can be taken. It also highlights areas within the text that are of particular importance.

**INFORMATION**

This gives advice on applications and provides information on special features.

Safety**Intended use**

The safety relay provides a safety-related interruption of a safety circuit.

The safety relay meets the requirements of EN 60947-5-1 and EN 60204-1 and may be used in applications with:

- ▶ E-STOP pushbuttons
- ▶ Safety gates

The following is deemed improper use in particular

- ▶ Any component, technical or electrical modification to the product,
- ▶ Use of the product outside the areas described in this operating manual,
- ▶ Use of the product outside the technical details (see [Technical details](#)  15).

**NOTICE****EMC-compliant electrical installation**

The product is designed for use in an industrial environment. The product may cause interference if installed in other environments. If installed in other environments, measures should be taken to comply with the applicable standards and directives for the respective installation site with regard to interference.

Safety regulations**Safety assessment**

Before using a device, a safety assessment in accordance with the Machinery Directive is required.

The product as an individual component fulfils the functional safety requirements in accordance with EN ISO 13849 and EN 62061. However, this does not guarantee the functional safety of the overall plant/machine. To achieve the relevant safety level of the overall plant/machine's required safety functions, each safety function needs to be considered separately.

Use of qualified personnel

The products may only be assembled, installed, programmed, commissioned, operated, maintained and decommissioned by persons who are competent to do so.

A competent person is a qualified and knowledgeable person who, because of their training, experience and current professional activity, has the specialist knowledge required. To be able to inspect, assess and operate devices, systems and machines, the person has to be informed of the state of the art and the applicable national, European and international laws, directives and standards.

It is the company's responsibility only to employ personnel who

- ▶ Are familiar with the basic regulations concerning health and safety / accident prevention,
- ▶ Have read and understood the information provided in the section entitled Safety
- ▶ Have a good knowledge of the generic and specialist standards applicable to the specific application.

Warranty and liability

All claims to warranty and liability will be rendered invalid if

- ▶ The product was used contrary to the purpose for which it is intended,
- ▶ Damage can be attributed to not having followed the guidelines in the manual,
- ▶ Operating personnel are not suitably qualified,
- ▶ Any type of modification has been made (e.g. exchanging components on the PCB boards, soldering work etc.).

Disposal

- ▶ In safety-related applications, please comply with the mission time T_M in the safety-related characteristic data.
- ▶ When decommissioning, please comply with local regulations regarding the disposal of electronic devices (e.g. Electrical and Electronic Equipment Act).

For your safety

The unit meets all the necessary conditions for safe operation. However, please note the following:

- ▶ Note for overvoltage category III: If voltages higher than low voltage (>50 VAC or >120 VDC) are present on the unit, connected control elements and sensors must have a rated insulation voltage of at least 250 V.

Unit features

- ▶ Positive-guided relay outputs:
 - 3 safety contacts (N/O), instantaneous
 - 1 auxiliary contact (N/C), instantaneous
- ▶ Connection options for:
 - Emergency stop pushbuttons
 - Safety gate limit switches
 - Reset buttons
 - PSENmech, PSENmag

- ▶ LED for:
 - Supply voltage
 - Switch status channel 1
 - Switch status channel 2

Safety features

The relay meets the following safety requirements:

- ▶ The circuit is redundant with built-in self-monitoring.
- ▶ The safety function remains effective in the case of a component failure.
- ▶ The correct opening and closing of the safety function relays is tested automatically in each on-off cycle.

Block diagram/terminal configuration

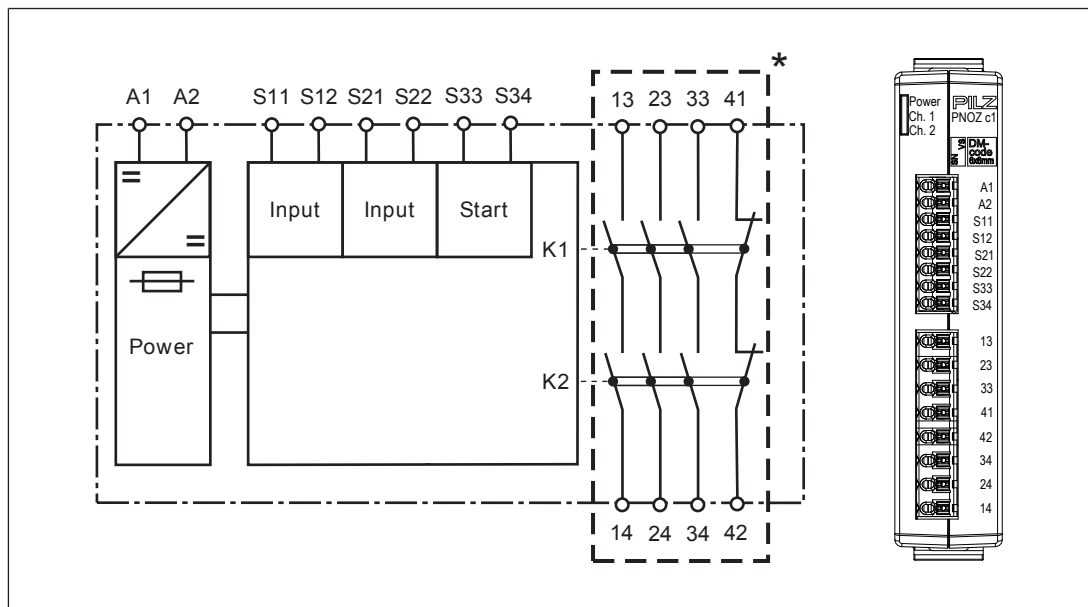

* Insulation from non-marked area: Safe separation (overvoltage category III),
 Insulation between relay contacts: basic insulation (overvoltage category III), safe separation (overvoltage category II)

Function description

When the supply voltage is supplied, the "POWER" LED illuminates. The unit is ready for operation when the start circuit is closed.

- ▶ Input circuits closed (e.g. the E-STOP button is not pressed): The safety contacts are closed and the auxiliary contact is open.
- ▶ Input circuit open (e.g. E-STOP operated): The safety contacts are open and the auxiliary contact is closed.

- ▶ Dual-channel operation with detection of shorts across contacts: redundant input circuit, detects
 - earth faults in the start and input circuit,
 - shorts between contacts in the input circuit.
- ▶ Automatic start: Unit is active once the input circuit has been closed.
- ▶ Manual start Unit is active once the input circuit is closed and then the start circuit is closed.
- ▶ Increase in the number of available contacts by connecting contact expansion modules or external contactors/relays.

Installation

- ▶ The unit should be installed in a control cabinet with a protection type of at least IP54.
- ▶ Use the notch on the rear of the unit to attach it to a DIN rail.
- ▶ Ensure the unit is mounted securely on a vertical DIN rail (35 mm) by using a fixing element (e.g. retaining bracket or an end angle).

Wiring

Please note:

- ▶ Information given in the "Technical details" must be followed.
- ▶ Outputs 13-14, 23-24, 33-34 are safety contacts; output 41-42 is an auxiliary contact (e.g. for display).
- ▶ Auxiliary contact 41-42 should **not** be used for safety circuits!
- ▶ To prevent contact welding, a fuse should be connected before the output contacts (see [see technical details \[15\]](#)).
- ▶ Calculation of the max. cable length l_{\max} in the input circuit:

$$l_{\max} = \frac{R_{l_{\max}}}{R_l / \text{km}}$$

$R_{l_{\max}}$ = max. overall cable resistance (see [see technical details \[15\]](#))

R_l / km = cable resistance/km

- ▶ Use copper wiring with a temperature stability of 60/75 °C.
- ▶ To prevent EMC interferences (particularly common-mode interferences) the measures described in EN 60204-1 must be executed. This includes the separate routing of cables of the control circuits (input, start and feedback loop) from other cables for energy transmission or the shielding of cables, for example.
- ▶ Sufficient fuse protection must be provided on all output contacts with capacitive and inductive loads.
- ▶ Do not switch low currents using contacts that have been used previously with high currents.
- ▶ When connecting magnetically operated, reed proximity switches, ensure that the max. peak inrush current (on the input circuit) does not overload the proximity switch.
- ▶ The power supply must comply with the regulations for extra low voltages with protective electrical separation (SELV, PELV) in accordance with VDE 0100, Part 410.

Important for detection of shorts across contacts:

As this function for detecting shorts across contacts is not failsafe, it is tested by Pilz during the final control check. If there is a danger of exceeding the cable runs, we recommend the following test after the installation of the device:

1. Unit ready for operation (output contacts closed)
2. Short circuit the test terminals S12, S22 for detecting shorts across the inputs.
3. The unit's fuse must be triggered and the output contacts must open. Cable lengths in the scale of the maximum length can delay the fuse triggering for up to 2 minutes.
4. Reset the fuse: remove the short circuit and switch off the supply voltage for approx. 1 minute.

Connect cable with crimp connector

- ▶ Strip the cable [1] and apply a crimp connector.
- ▶ Insert the stripped cable with the crimp connector applied into the terminal point [2] [3] as far as it will go.

**NOTICE**

Do not use a tool to connect the cable.

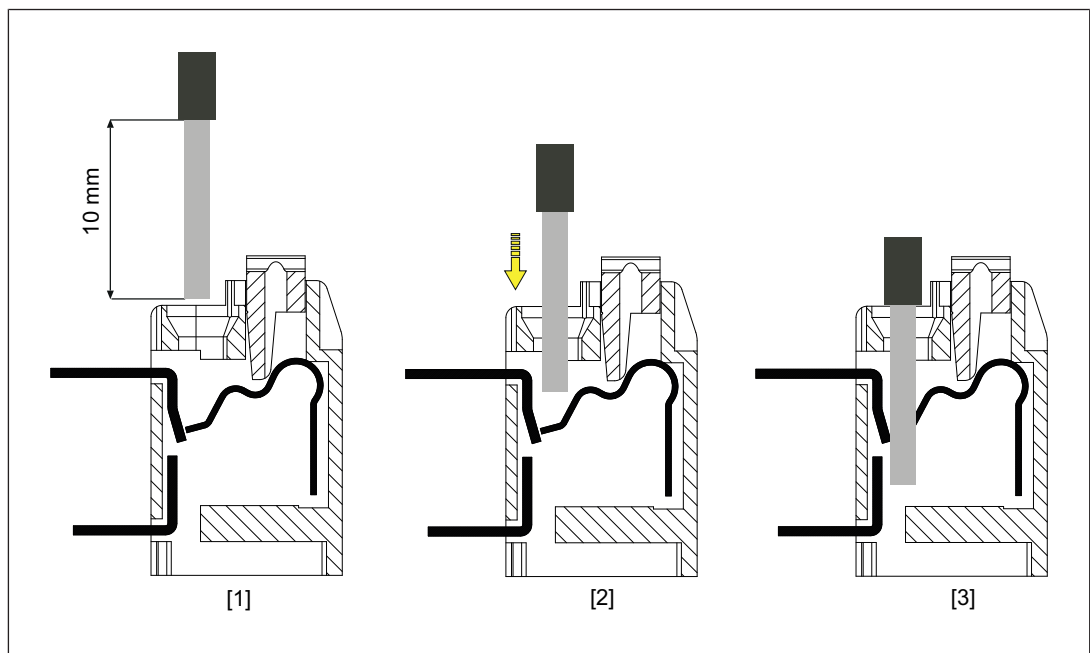

Fig.: Connect cable with crimp connector

Connect cable without crimp connector

- ▶ Strip the cable [1].
- ▶ Using the screwdriver, press the actuator button [2] and insert the stripped cable into the terminal point [2] [3] as far as it will go.

We recommend you use a screw driver with a 0.4 x 2.5 mm (DIN 5264) blade!

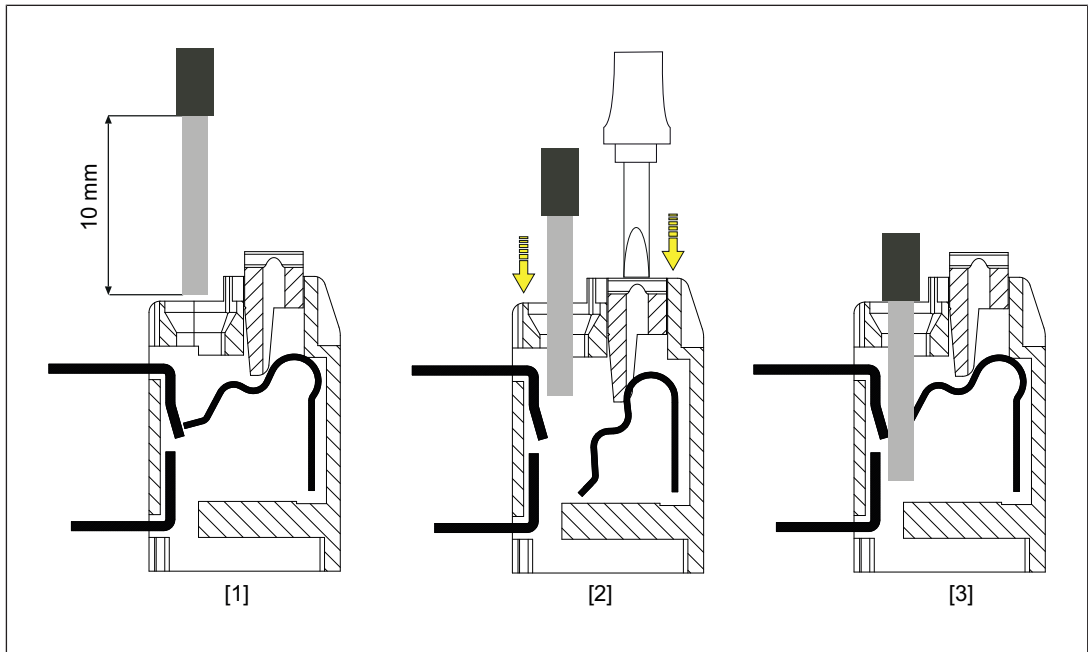

Fig.: Connect cable without crimp connector

Disconnect cable

We recommend you use a screw driver with a 0.4 x 2.5 mm (DIN 5264) blade!

- ▶ Using the screwdriver, press the actuator button and pull the cable out of the terminal point [4].

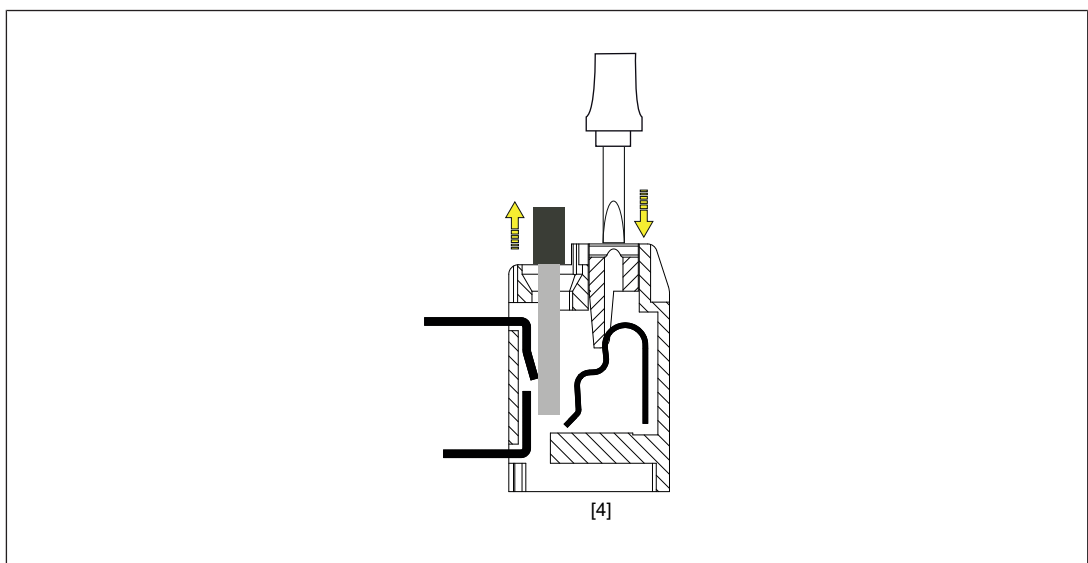

Fig.: Disconnect cable

Preparing for operation

Supply voltage	AC	DC
Input circuit	Single-channel	Dual-channel
E-STOP with detection of shorts across contacts		
Safety gate with detection of shorts across contacts		
Start circuit/feedback loop	Start circuit	Feedback loop
automatic start		
Manual start		

**NOTICE****In the event of an automatic start or manual start with bridged start contact (fault):**

The unit starts up automatically when the safeguard is reset, e.g. when the E-STOP pushbutton is released. Use external circuit measures to prevent an unexpected restart.

Operation

When the relay outputs are switched on, the mechanical contact on the relay cannot be tested automatically. Depending on the operational environment, measures to detect the non-opening of switching elements may be required under some circumstances.

When the product is used in accordance with the European Machinery Directive, a check must be carried out to ensure that the safety contacts on the relay outputs open correctly. Open the safety contacts (switch off output) and start the device again, so that the internal diagnostics can check that the safety contacts open correctly

- ▶ for SIL CL 3/PL e at least 1x per month
- ▶ for SIL CL 2/PL d at least 1x per year



**NOTICE**

The safety function should be checked after initial commissioning and each time the plant/machine is changed. The safety functions may only be checked by qualified personnel.

The unit is ready for operation when the Power LED is permanently lit.

LEDs indicate the status and errors during operation:

Status indicators**Legend**

-  LED on
-  LED off

 **POWER**
Supply voltage is present.

 **CH.1**
Input S21-S22 is closed.

 **CH.2**
Input S11-S12 is closed.

Error indicators

- **All LEDs off**

Diagnostics: Short across contacts/earth fault; unit switched off

- ▶ Remedy: Rectify short across contacts/earth fault, switch off supply voltage for 1 min.

- **LED Power off**

Diagnostics: Short circuit or supply voltage failure

- ▶ Remedy: Rectify short circuit or connect supply voltage.

Faults - malfunctions

- ▶ Contact malfunctions: If the contacts have welded, reactivation will not be possible after the input circuit has opened.

Dimensions in mm

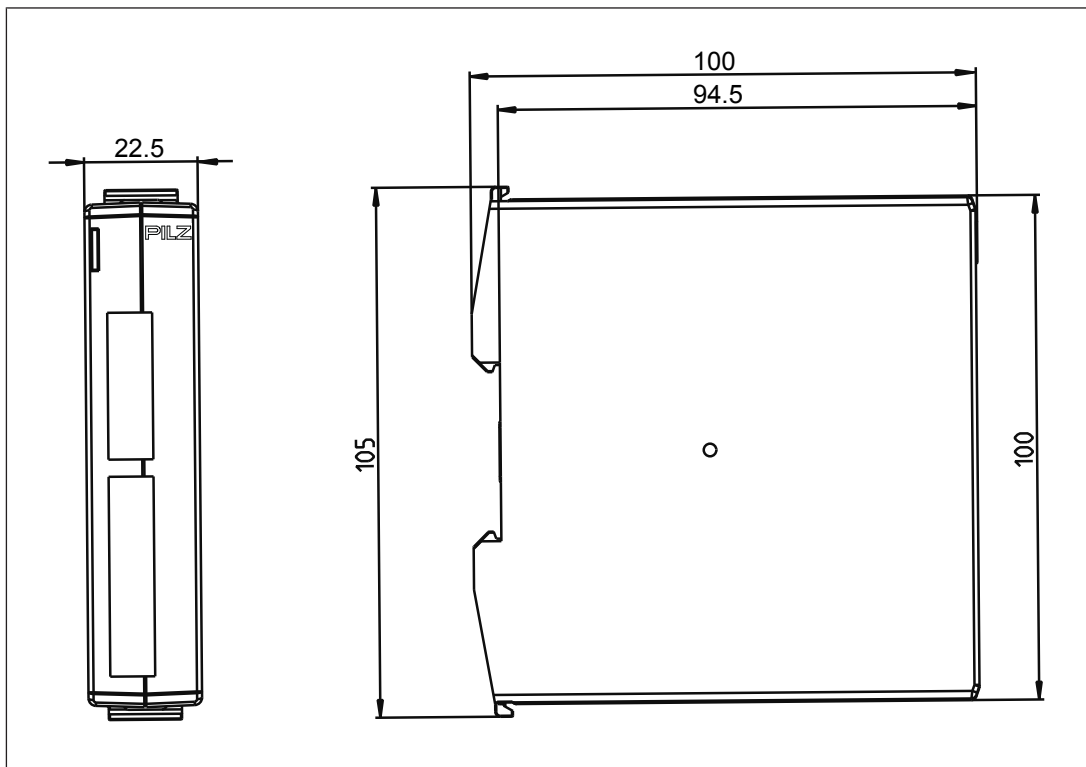

Technical details

General	
Certifications	CCC, CE, EAC, TÜV, UKCA, cULus Listed
Electrical data	
Supply voltage	
Voltage	24 V
Kind	DC
Voltage tolerance	-15 %/+10 %
Output of external power supply (DC)	2,5 W
Residual ripple DC	160 %
Duty cycle	100 %
Max. inrush current impulse	
Current pulse, A1	1,8 A
Pulse duration, A1	4 ms
Inputs	
Number	2
Voltage at	
Input circuit DC	24 V
Start circuit DC	24 V
Feedback loop DC	24 V
Current at	
Input circuit DC	30 mA
Start circuit DC	40 mA
Feedback loop DC	40 mA
Max. inrush current impulse	
Current pulse, input circuit	0,35 A
Pulse duration, input circuit	25 ms
Current pulse, feedback loop	0,15 A
Pulse duration, feedback loop	2 ms
Current pulse, start circuit	0,15 A
Pulse duration, start circuit	2 ms
Min. input resistance at power-on	88 Ohm
Max. overall cable resistance R _{lmax}	
Dual-channel with detection of shorts across contacts at UB DC	15 Ohm
Relay outputs	
Number of output contacts	
Safety contacts (N/O), instantaneous	3
Auxiliary contacts (N/C)	1
Max. short circuit current I _K	1 kA
Utilisation category	
In accordance with the standard	EN 60947-4-1

Relay outputs

Utilisation category of safety contacts

AC1 at	240 V
Min. current	0,01 A
Max. current	6 A
Max. power	1500 VA
DC1 at	24 V
Min. current	0,01 A
Max. current	6 A
Max. power	150 W

Utilisation category of auxiliary contacts

AC1 at	240 V
Min. current	0,01 A
Max. current	6 A
Max. power	1500 VA
DC1 at	24 V
Min. current	0,01 A
Max. current	6 A
Max. power	150 W

Utilisation category

In accordance with the standard	EN 60947-5-1
---------------------------------	---------------------

Utilisation category of safety contacts

AC15 at	230 V
Max. current	5 A
DC13 (6 cycles/min) at	24 V
Max. current	5 A

Utilisation category of auxiliary contacts

AC15 at	230 V
Max. current	5 A
DC13 (6 cycles/min) at	24 V
Max. current	5 A

Utilisation category in accordance with UL

Voltage	240 V AC G.U. (same polarity)
With current	6 A
Voltage	24 V DC G. U.
With current	6 A

External contact fuse protection, safety contacts

In accordance with the standard	EN 60947-5-1
Max. melting integral	260 A²s
Blow-out fuse, slow	6 A
Blow-out fuse, gG	6 A
Circuit breaker 24V AC/DC, characteristic B/C	6 A

Relay outputs

External contact fuse protection, auxiliary contacts

Max. melting integral	260 A²s
Blow-out fuse, slow	6 A
Blow-out fuse, gG	6 A
Circuit breaker 24 V AC/DC, characteristic B/C	6 A

Contact material **AgCuNi + 0,2 µm Au****Conventional thermal current while loading several contacts**I_{th} per contact at UB DC; AC1: 240 V, DC1: 24 V

Conv. therm. current with 1 contact	6 A
Conv. therm. current with 2 contacts	6 A
Conv. therm. current with 3 contacts	5 A

Times

Switch-on delay

With automatic start typ.	250 ms
With automatic start max.	450 ms
With automatic start after power on typ.	250 ms
With automatic start after power on max.	450 ms
With manual start typ.	125 ms
With manual start max.	450 ms

Delay-on de-energisation

With E-STOP typ.	15 ms
With E-STOP max.	30 ms
With power failure typ.	60 ms
With power failure max.	100 ms

Recovery time at max. switching frequency 1/s

After E-STOP	300 ms
After power failure	300 ms

Supply interruption before de-energisation **20 ms**Simultaneity, channel 1 and 2 max. **∞****Environmental data**Climatic suitability **EN 60068-2-78**

Ambient temperature

Temperature range **-10 - 55 °C**

Storage temperature

Temperature range **-40 - 85 °C**

Climatic suitability

Humidity **93 % r. h. at 40 °C**Condensation during operation **Not permitted**EMC **EN 60947-5-1, EN 61000-6-2, EN 61000-6-4, EN 61326-3-1**

Vibration

In accordance with the standard	EN 60068-2-6
Frequency	10 - 55 Hz
Amplitude	0,35 mm

Environmental data

Airgap creepage	
In accordance with the standard	EN 60947-1
Overvoltage category	III
Pollution degree	2
Rated insulation voltage	250 V
Rated impulse withstand voltage	6 kV
Protection type	
Housing	IP40
Terminals	IP20
Mounting area (e.g. control cabinet)	IP54

Mechanical data

Mounting position	Any
Mechanical life	10,000,000 cycles
Material	
Bottom	PC
Top	PC
Connection type	Spring-loaded terminal
Mounting type	Fixed
Conductor cross section with spring-loaded terminals	
1 core flexible without crimp connector	0,25 - 1,5 mm², 24 - 16 AWG
1 core flexible with crimp connector	0,25 - 0,75 mm², 24 - 20 AWG
Spring-loaded terminals: Terminal points per connection	1
Stripping length with spring-loaded terminals	10 mm
Dimensions	
Height	105 mm
Width	22,5 mm
Depth	100 mm
Weight	160 g

Where standards are undated, the 2020-07 latest editions shall apply.

Safety characteristic data



NOTICE

You must comply with the safety characteristic data in order to achieve the required safety level for your plant/machine.

Operating mode	EN ISO 13849-1: 2015	EN ISO 13849-1: 2015	EN 62061 SIL CL	EN 62061 PFH _D [1/h]	IEC 61511 SIL	IEC 61511 PFD	EN ISO 13849-1: 2015 T _M [year]
PL		Category					

Safety contacts, instantaneous

PL e	Cat. 4	SIL CL 3	2,31E-09	SIL 3	2,03E-06	20
------	--------	----------	----------	-------	----------	----

Explanatory notes for the safety-related characteristic data:

- ▶ The SIL CL value in accordance with EN 62061 corresponds to the SIL value in accordance with EN 61508.
- ▶ T_M is the maximum mission time in accordance with EN ISO 13849-1. The value also applies as the retest interval in accordance with EN 61508-6 and IEC 61511 and as the proof test interval and mission time in accordance with EN 62061.

All the units used within a safety function must be considered when calculating the safety characteristic data.



INFORMATION

A safety function's SIL/PL values are **not** identical to the SIL/PL values of the units that are used and may be different. We recommend that you use the PAScal software tool to calculate the safety function's SIL/PL values.

Supplementary data



CAUTION!

It is essential to consider the relay's service life graphs. The relay outputs' safety-related characteristic data is only valid if the values in the service life graphs are met.

The PFH value depends on the switch frequency and the load of the relay output. If the service life graphs are not accessible, the stated PFH value can be used irrespective of the switch frequency and the load, as the PFH value already considers the relay's B10d value as well as the failure rates of the other components.

Service life graph

The service life graphs indicate the number of cycles from which failures due to wear must be expected. The wear is mainly caused by the electrical load; the mechanical load is negligible.

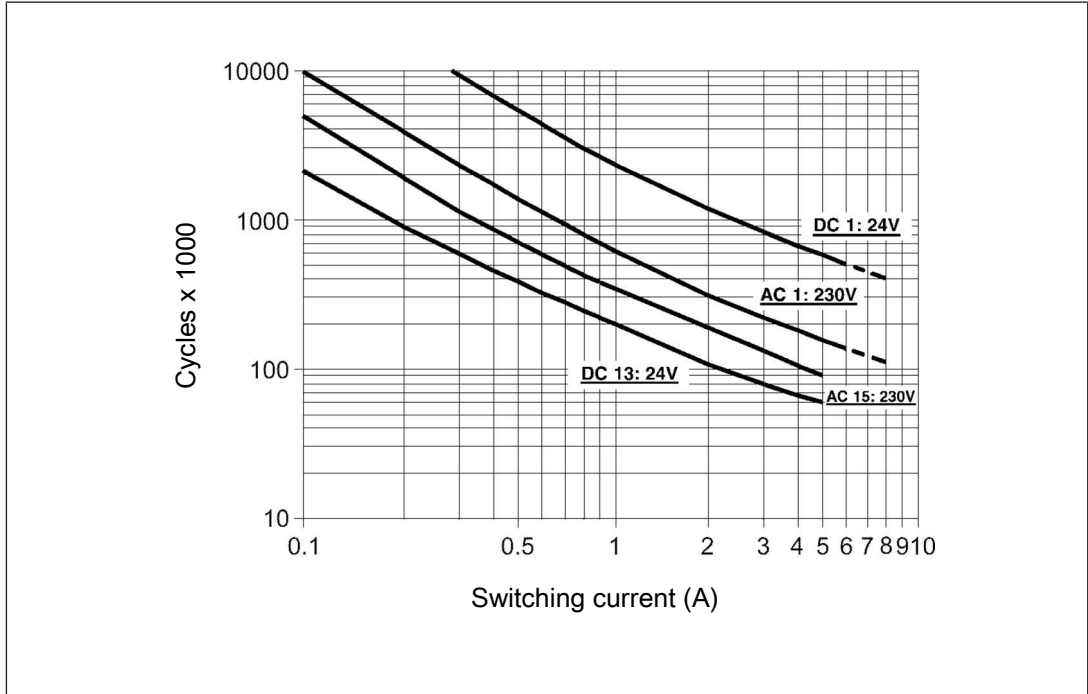

Fig.: Service life graphs at 24 V DC and 230 V AC

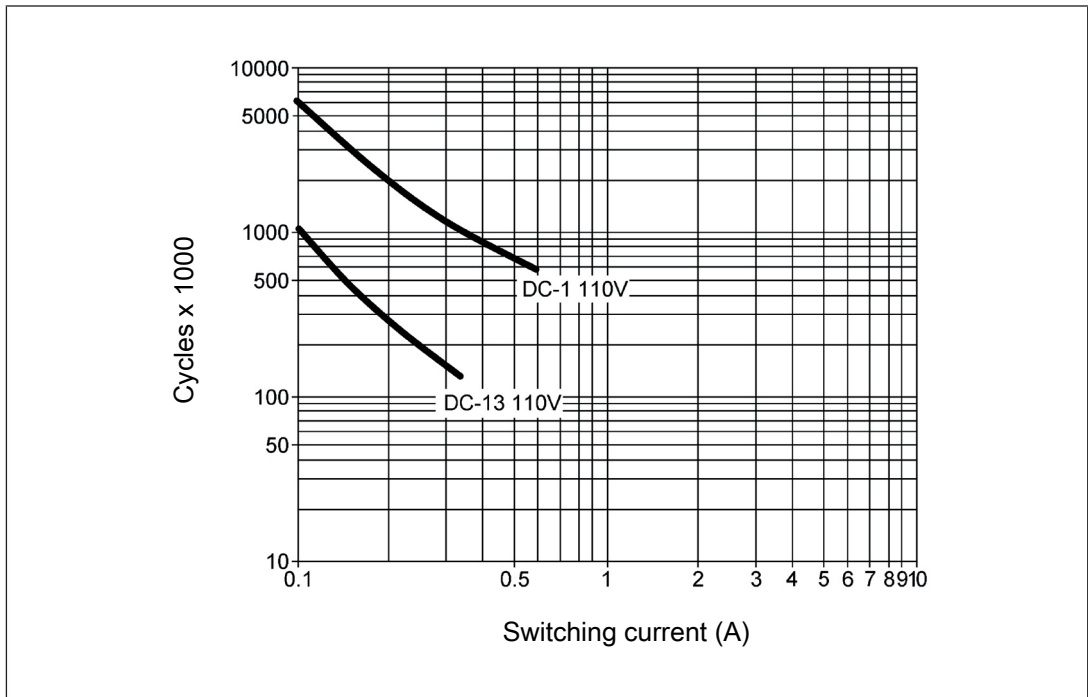



Fig.: Service life graphs at 110 V DC

Example

- ▶ Inductive load: 0.2 A
- ▶ Utilisation category: AC15
- ▶ Contact service life: 2 000 000 cycles

Provided the application to be implemented requires fewer than 2 000 000 cycles, the PFH value (see [Technical details](#) [ 15]) can be used in the calculation.

To increase the service life, sufficient spark suppression must be provided on all output contacts. With capacitive loads, any power surges that occur must be noted. With DC contactors, use flywheel diodes for spark suppression.

Order reference

Product type	Features	Terminals	Order no.
PNOZ c1	24 V DC	With spring-loaded terminals	710001

EC Declaration of Conformity

This product/these products meet the requirements of the directive 2006/42/EC for machinery of the European Parliament and of the Council. The complete EC Declaration of Conformity is available on the Internet at www.pilz.com/downloads.

Authorised representative: Norbert Fröhlich, Pilz GmbH & Co. KG, Felix-Wankel-Str. 2, 73760 Ostfildern, Germany

UKCA-Declaration of Conformity

This product(s) complies with following UK legislation: Supply of Machinery (Safety) Regulation 2008.

The complete UKCA Declaration of Conformity is available on the Internet at www.pilz.com/support/downloads.

Representative: Pilz Automation Technology, Pilz House, Little Colliers Field, Corby, Northamptonshire, NN18 8TJ United Kingdom, eMail: mail@pilz.co.uk

► Support

Technical support is available from Pilz round the clock.

Americas

Brazil

+55 11 97569-2804

Canada

+1 888 315 7459

Mexico

+52 55 5572 1300

USA (toll-free)

+1 877-PILZUSA (745-9872)

Asia

China

+86 21 60880878-216

Japan

+81 45 471-2281

South Korea

+82 31 778 3300

Australia and Oceania

Australia

+61 3 95600621

New Zealand

+64 9 6345350

Europe

Austria

+43 1 7986263-0

Belgium, Luxembourg

+32 9 3217570

France

+33 3 88104003

Germany

+49 711 3409-444

Ireland

+353 21 4804983

Italy, Malta

+39 0362 1826711

Scandinavia

+45 74436332

Spain

+34 938497433

Switzerland

+41 62 88979-32

The Netherlands

+31 347 320477

Turkey

+90 216 5775552

United Kingdom

+44 1536 462203

You can reach our international hotline on:

+49 711 3409-222

support@pilz.com

Pilz develops environmentally-friendly products using ecological materials and energy-saving technologies. Offices and production facilities are ecologically designed, environmentally-aware and energy-saving. So Pilz offers sustainability, plus the security of using energy-efficient products and environmentally-friendly solutions.



We are represented internationally. Please refer to our homepage www.pilz.com for further details or contact our headquarters.

Headquarters: Pilz GmbH & Co. KG, Felix-Wankel-Straße 2, 73760 Ostfildern, Germany
Telephone: +49 711 3409-0, Telefax: +49 711 3409-133, E-Mail: info@pilz.com, Internet: www.pilz.com

PILZ
THE SPIRIT OF SAFETY

CECE®, CHRE®, CMSE®, InduraNET p®, Leansafe®, Master of Safety®, Master of Security®, PAS4000®, PAScall®, PASconfig®, Pilz®, PTT®, PLID®, PMCPirimo®, PMCPiritego®, PMCTendo®, PMD®, PMJ®, PNOZ®, PRBM®, PRCM®, PRIMO®, PRM®, PSEN®, PSENi®, PSS®, PVS®, SafetyBUS p®, SafetyEYE®, SafetyNET p®, THE SPIRIT OF SAFETY® are registered and protected trademarks of Pilz GmbH & Co. KG in some countries. We would point out that product features may vary from the details stated in this document, depending on the status at the time of publication and the scope of the equipment. We accept no responsibility for the validity, accuracy and entirety of the text and graphics presented in this information. Please contact our Technical Support if you have any questions.

22197-EN-07, 2022.04 Printed in Germany
© Pilz GmbH & Co. KG, 2019