



Visualisation; Diagnostics

Easy to Configure

Programming IEC 61131-3

Rapid Installation

PNOZ e4.1p

PILZ

THE SPIRIT OF SAFETY

► Safety relays

This document is the original document.

All rights to this documentation are reserved by Pilz GmbH & Co. KG. Copies may be made for the user's internal purposes. Suggestions and comments for improving this documentation will be gratefully received.

Source code from third-party manufacturers or open source software has been used for some components. The relevant licence information is available on the Internet on the Pilz homepage.

Pilz®, PIT®, PMI®, PNOZ®, Primo®, PSEN®, PSS®, PVIS®, SafetyBUS p®, SafetyEYE®, SafetyNET p®, the spirit of safety® are registered and protected trademarks of Pilz GmbH & Co. KG in some countries.



SD means Secure Digital

Introduction	5
Validity of documentation	5
Using the documentation	5
Definition of symbols	5
Safety	6
Intended use	6
Safety regulations	7
Safety assessment	7
Use of qualified personnel	7
Warranty and liability	7
Disposal	7
For your safety	8
Unit features	8
Safety features	8
Block diagram/terminal configuration	9
Function description	9
Operating modes	10
Installation	10
Wiring	11
Preparing for operation	12
Supply voltage	12
Input circuit	12
Start circuit	13
Feedback loop	14
Logic connection between several units	14
Logic inputs S35 and S36	15
Examples	15
Operation	20
Status indicators	20
Faults - malfunctions	21
Dimensions in mm	26
Technical details	26
Safety characteristic data	30

Remove plug-in terminals	31
Order reference	31
Product	31
Accessories	31

Introduction

Validity of documentation

This documentation is valid for the product PNOZ e4.1p. It is valid until new documentation is published.

This operating manual explains the function and operation, describes the installation and provides guidelines on how to connect the product.

Using the documentation

This document is intended for instruction. Only install and commission the product if you have read and understood this document. The document should be retained for future reference.

Definition of symbols

Information that is particularly important is identified as follows:



DANGER!

This warning must be heeded! It warns of a hazardous situation that poses an immediate threat of serious injury and death and indicates preventive measures that can be taken.



WARNING!

This warning must be heeded! It warns of a hazardous situation that could lead to serious injury and death and indicates preventive measures that can be taken.



CAUTION!

This refers to a hazard that can lead to a less serious or minor injury plus material damage, and also provides information on preventive measures that can be taken.



NOTICE

This describes a situation in which the product or devices could be damaged and also provides information on preventive measures that can be taken. It also highlights areas within the text that are of particular importance.

**INFORMATION**

This gives advice on applications and provides information on special features.

Safety**Intended use**

The safety relay PNOZ e4.1p provides a safety-related interruption of a safety circuit.

The unit meets the requirements of EN ISO 13849-1 up to and including PL d (Cat. 3). The safety mat only partially meets this requirement (see Clause 4.15 of EN ISO 13856-1).

They may only be used as a safety system in conjunction with safety mats that are specified in the unit features. The safety relay is used for signal processing and as a shutdown device in accordance with EN ISO 13856-1. When using safety mats, please refer to the manufacturer's documentation.

When using safety mats, please note the following:

- ▶ The safety mats trigger only when they are stood on by persons weighing more than 35 kg.
- ▶ The following are not permitted: Walking aids such as canes and wheeled vehicles

The following is deemed improper use in particular

- ▶ Any component, technical or electrical modification to the product,
- ▶ Use of the product outside the areas described in this manual,
- ▶ Use of the product outside the technical details (see [Technical details](#)  26]).

**NOTICE****EMC-compliant electrical installation**

The product is designed for use in an industrial environment. The product may cause interference if installed in other environments. If installed in other environments, measures should be taken to comply with the applicable standards and directives for the respective installation site with regard to interference.

Safety regulations

Safety assessment

Before using a device, a safety assessment in accordance with the Machinery Directive is required.

The product as an individual component fulfils the functional safety requirements in accordance with EN ISO 13849 and EN 62061. However, this does not guarantee the functional safety of the overall plant/machine. To achieve the relevant safety level of the overall plant/machine's required safety functions, each safety function needs to be considered separately.

Use of qualified personnel

The products may only be assembled, installed, programmed, commissioned, operated, maintained and decommissioned by persons who are competent to do so.

A competent person is a qualified and knowledgeable person who, because of their training, experience and current professional activity, has the specialist knowledge required. To be able to inspect, assess and operate devices, systems and machines, the person has to be informed of the state of the art and the applicable national, European and international laws, directives and standards.

It is the company's responsibility only to employ personnel who

- ▶ Are familiar with the basic regulations concerning health and safety / accident prevention,
- ▶ Have read and understood the information provided in the section entitled Safety
- ▶ Have a good knowledge of the generic and specialist standards applicable to the specific application.

Warranty and liability

All claims to warranty and liability will be rendered invalid if

- ▶ The product was used contrary to the purpose for which it is intended,
- ▶ Damage can be attributed to not having followed the guidelines in the manual,
- ▶ Operating personnel are not suitably qualified,
- ▶ Any type of modification has been made (e.g. exchanging components on the PCB boards, soldering work etc.).

Disposal

- ▶ In safety-related applications, please comply with the mission time T_M in the safety-related characteristic data.
- ▶ When decommissioning, please comply with local regulations regarding the disposal of electronic devices (e.g. Electrical and Electronic Equipment Act).

For your safety

The unit meets all the necessary conditions for safe operation. However, please note the following:

You must follow the instructions for installing the safety mats as stated in EN ISO 13856-1, Annex B.5.

If you are using a safety mat system with reset function, the reset must occur outside of the danger zone, with insight into the danger zone.

The function of the safety system must be checked at regular intervals.

Unit features

- ▶ Outputs using semiconductor technology:
 - 2 safety outputs
 - 1 auxiliary output
 - 2 test pulse outputs
- ▶ Connection options:
 - Safety mats from Mayser, type SM/BK
 - Safety mats from Bircher, type ESM5x
- ▶ It is possible to control a PSS
- ▶ LED display for:
 - Supply voltage
 - Switch state of safety outputs
- ▶ 2 logic inputs (AND/OR) for logic connections between several units
- ▶ Feedback loop for monitoring external contactors
- ▶ Detection of shorts across contacts via test pulse outputs

Safety features

The relay meets the following safety requirements:

- ▶ The circuit is redundant with built-in self-monitoring.
- ▶ The safety device remains effective in the case of a component failure.
- ▶ The safety outputs are tested periodically using an off-test.

Block diagram/terminal configuration

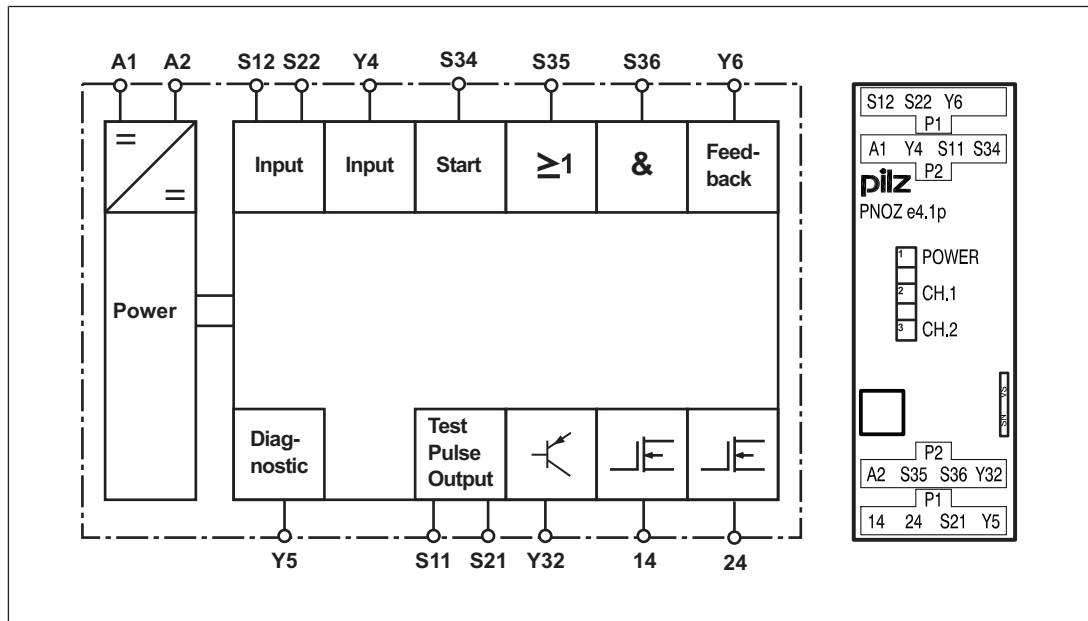

Function description

When supply voltage is applied and the set operating mode is detected (initialisation phase), the "POWER" LED is lit. The unit is ready for operation when the feedback loop is closed.

- ▶ Safety mat not activated:
 - There are high signals at safety outputs 14 and 24 and auxiliary output Y32.
 - The LEDs "CH.1" and "CH.2" are lit.
- ▶ Safety mat activated:
 - There are low signals at safety outputs 14 and 24 and auxiliary output Y32.
 - The LEDs "CH.1" and "CH.2" go out.

Feedback loop

Before a safety output is switched on, a test is run to establish whether the contacts ahead of feedback loop input Y6 are closed. If a contact is open, an error is detected and LEDs CH.1 and CH.2 will flash alternately. It will not be possible to switch the unit back on until the feedback loop is closed and the safety function has been reset.

The feedback loop contacts are also checked when the signal at the output changes from high to low. After this signal change, the contacts at the feedback loop input must close within 150 ms. If a contact is still open after 150 ms has elapsed, an error is detected and is displayed as a flashing code (1,8) (see [Faults - malfunctions \[21\]](#)). It will not be possible to switch the unit back on until the error has been rectified and the supply voltage has been switched off and then on again.

AND/OR connection

The PNOZ e4.1p has two logic inputs S35 (OR) and S36 (AND) for logic connections between several units.

Operating modes

- ▶ Automatic reset (start): Unit is active once the safety mat has been cleared.
- ▶ Manual restart (start): Unit is not active until the start button has been operated and then released and the safety mat has not been activated.
- ▶ The start-up test prevents automatic restarting after a power failure and subsequent return of voltage. The unit checks if the non-activated safety mat has been activated and cleared after the supply voltage was applied.
- ▶ Increase in the number of available contacts by connecting contact expansion modules or external contactors/relays.

Installation



CAUTION!

Electrostatic discharge can damage components on the safety system!

Ensure against discharge before touching the safety system, e.g. by touching an earthed, conductive surface or by wearing an earthed armband.

- ▶ The unit should be installed in a control cabinet with a protection type of at least IP54.
- ▶ Use the notch on the rear of the unit to attach it to a DIN rail (35 mm).
- ▶ When installed vertically: Secure the unit by using a fixing element (e.g. retaining bracket or end angle).



NOTICE

If you are connecting several units logically, please note the guidelines in the section entitled [Logic connection between several units](#)  14].

Wiring

Please note:

- ▶ Information given in the "[Technical details \[26\]](#)" must be followed.
- ▶ Use copper wiring with a temperature stability of 60/75 °C.
- ▶ To prevent EMC interferences (particularly common-mode interferences) the measures described in EN 60204-1 must be executed. This includes the separate routing of cables of the control circuits (input, start and feedback loop) from other cables for energy transmission or the shielding of cables, for example.
- ▶ Calculation of the max. cable length l_{\max} in the input circuit:

$$l_{\max} = \frac{R_{l_{\max}}}{R_l / \text{km}}$$

$R_{l_{\max}}$ = max. overall cable resistance (see [Technical details \[26\]](#))

R_l / km = cable resistance/km

- ▶ Cables that have to be laid outside the control cabinet must be protected from mechanical damage, e.g. by installing them in a conduit.
- ▶ The unit and the input circuits must always be supplied by a single power supply.
- ▶ Safety outputs 14 and 24 should exclusively be used for safe applications.
- ▶ You must comply with the idling capacity at safety outputs 14 and 24 (see [Technical details \[26\]](#)).
- ▶ To suppress the pulse on switching off at safety outputs 14 and 24, use the terminal block with filter (see [Order reference \[31\]](#)).
- ▶ Do not connect undesignated terminals.
- ▶ Only contactors with positive-guided contacts should be used for safety functions.
- ▶ Output Y32 is an auxiliary output, e.g. for communication with a PLC or text display.
- ▶ Auxiliary output Y32 should **not** be used for safety circuits!
- ▶ The safety outputs must **not** be connected to PLC inputs, but may be connected to PSS inputs.
- ▶ Use freewheel diodes to drive inductive loads (e.g. contactors or relays) with the safety/auxiliary outputs.
- ▶ The power supply must comply with the regulations for extra low voltages with protective electrical separation (SELV, PELV) in accordance with VDE 0100, Part 410.
- ▶ Terminal Y5 is provided for Pilz-internal diagnostic purposes.

Preparing for operation

Supply voltage

Supply voltage	AC	DC
	/	

Input circuit

Wire the safety mat to the inputs and determine via the wiring of programming input Y4 whether

- ▶ the unit's logic input S36 (AND) is used and whether
- ▶ the unit uses its safety outputs to control a PSS or PNOZelog unit.



CAUTION!

No additional loads may be connected to outputs that control a PSS.

If contactors alone are being controlled, we recommend the wiring for controlling the PSS.

Input circuit	OR logic input active and AND logic input active	OR logic input active or no logic connection
Control of a PSS (safety outputs cannot be used for logic functions)		
Control of a logic input or cascading input		

Example: Connecting several safety mats

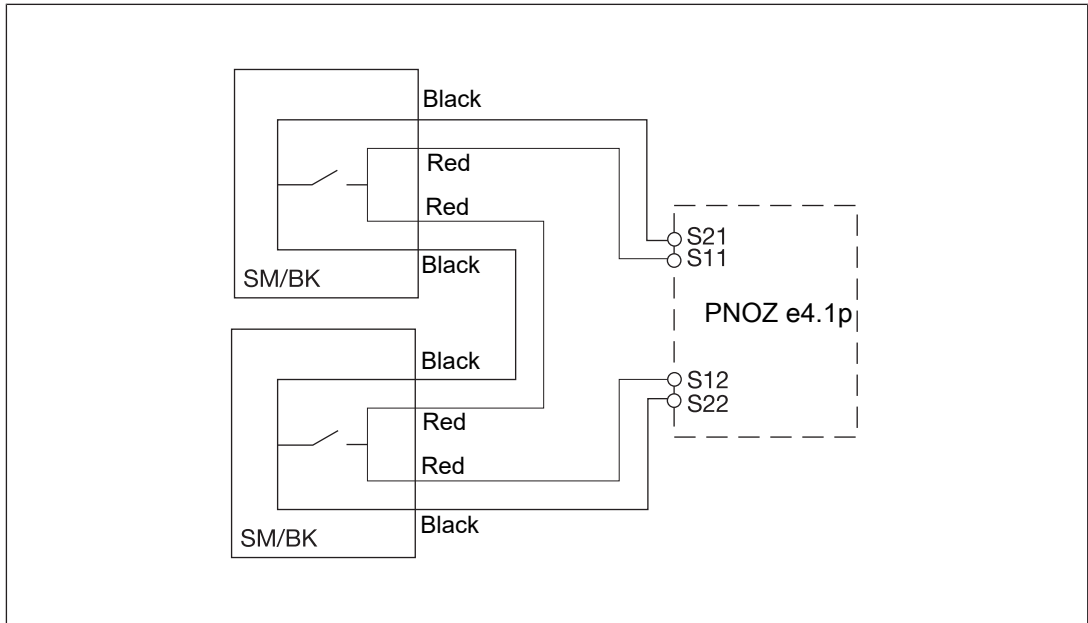

Start circuit

The start circuit determines the safety system's reset properties.

Start circuit	Automatic reset (start)	Manual reset (start)
Safety mat without start-up test		
Safety mat with start-up test		



NOTICE

With automatic reset (start)

The unit starts automatically when the safeguard is reset, e.g. after the safety mat is cleared. Use external circuit measures to prevent an unexpected restart.

Feedback loop

Contacts from external contactors can be connected between Y6 and A1.

▶ Feedback loop unconnected:

If you do not wish to connect any contacts to the feedback loop, Y6 must be connected to A1.





CAUTION!

Do **not** connect the contacts from external contactors in series to the start circuit.

Logic connection between several units

Units from the PNOZelog product range can be logically connected to each other and to units from the PNOZmulti product range. On the PNOZelog, input S35 is intended for the logic OR connection and input S36 for the logic AND connection. Safety outputs 14 and 24 on the PNOZelog are suitable for logic connections.

When linking several units logically, please note:

- ▶ When PNOZelog units are linked logically to each other, a safety output from a PNOZelog unit may be connected to logic inputs from one or more PNOZelog units.
- ▶ When linking PNOZelog units logically to PNOZmulti units
 - a cascading output from PNOZmulti units may be connected to logic inputs on PNOZelog units
 - or
 - a safety output from PNOZelog units may be connected to cascading inputs on PNOZmulti units.
- ▶ The unit with the lowest SIL/PL value determines the SIL/PL value of the entire circuit.
- ▶ PNOZ e1p, PNOZ e8.1p: These units do not have logic inputs. Their safety outputs can be used to logically link the units to the logic inputs of other PNOZelog units or to the cascading inputs from PNOZmulti units.
- ▶ Safety outputs from the PNOZ e1p are suitable for logic connections from unit version 3.0.
- ▶ Each safety output on a PNOZelog unit that is connected to the load may also be connected to the logic inputs of a maximum of four PNOZelog units ([Example 1](#) [ 16]).
- ▶ Up to 50 logic inputs from PNOZelog units can be connected to safety outputs with no load.
- ▶ Logically linking the units leads to delays when switching on and off (see on-delay and response time in the [Technical details](#) [ 26]). These are added up with each unit that is logically linked ([Example 3](#) [ 18]).
- ▶ Install all the logically linked units in the same control cabinet or ensure that faults regarding the units' connection are excluded, e.g. via protected installation of the connection cables.
- ▶ All linked units must be connected to the same supply voltage.

Logic inputs S35 and S36

The logic inputs are connected to each other as follows:

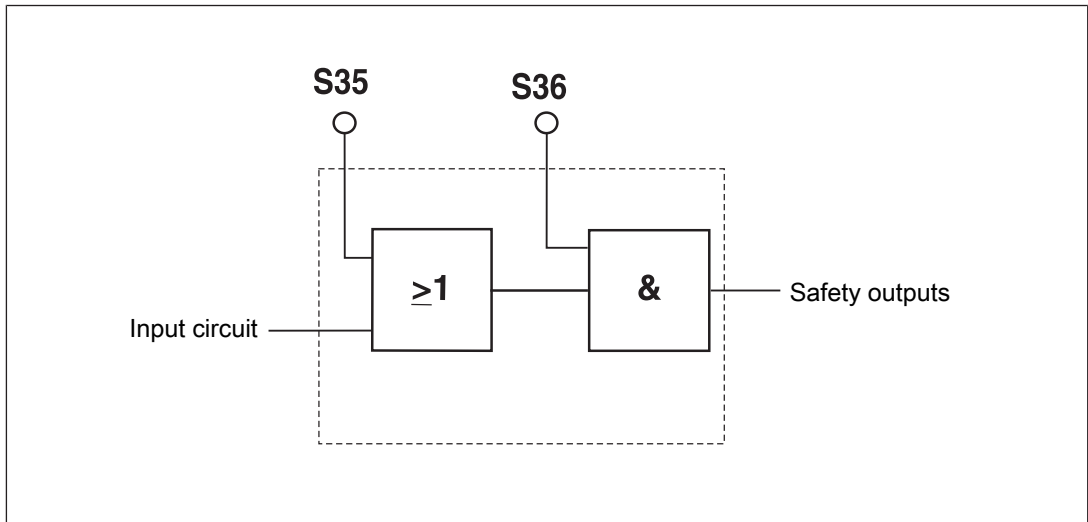

Logic inputs S35 and S36 from the PNOZ e4.1p enable additional PNOZelog or PNOZmulti units to be logically AND/OR connected.

Input circuit	Logic AND + OR connection	Logic AND connection	Logic OR connection
Control of a PSS			
Control of a PNOZelog unit			

Examples



WARNING!

Muting the safety function

A valid signal at the OR input of a PNOZelog unit mutes its safety function and can lead to the most serious injuries and death.

- Before using the OR function, carry out a risk analysis and use other measures to establish a safe condition.

The following examples represent various ways in which PNOZelog units can be logically connected. In all the application examples, 2 loads may also be connected to the safety outputs.

► Example 1:

Loads are connected to the safety outputs of Unit 1. In addition, a safety output is AND-linked to 4 other PNOZelog units via the logic input S36.

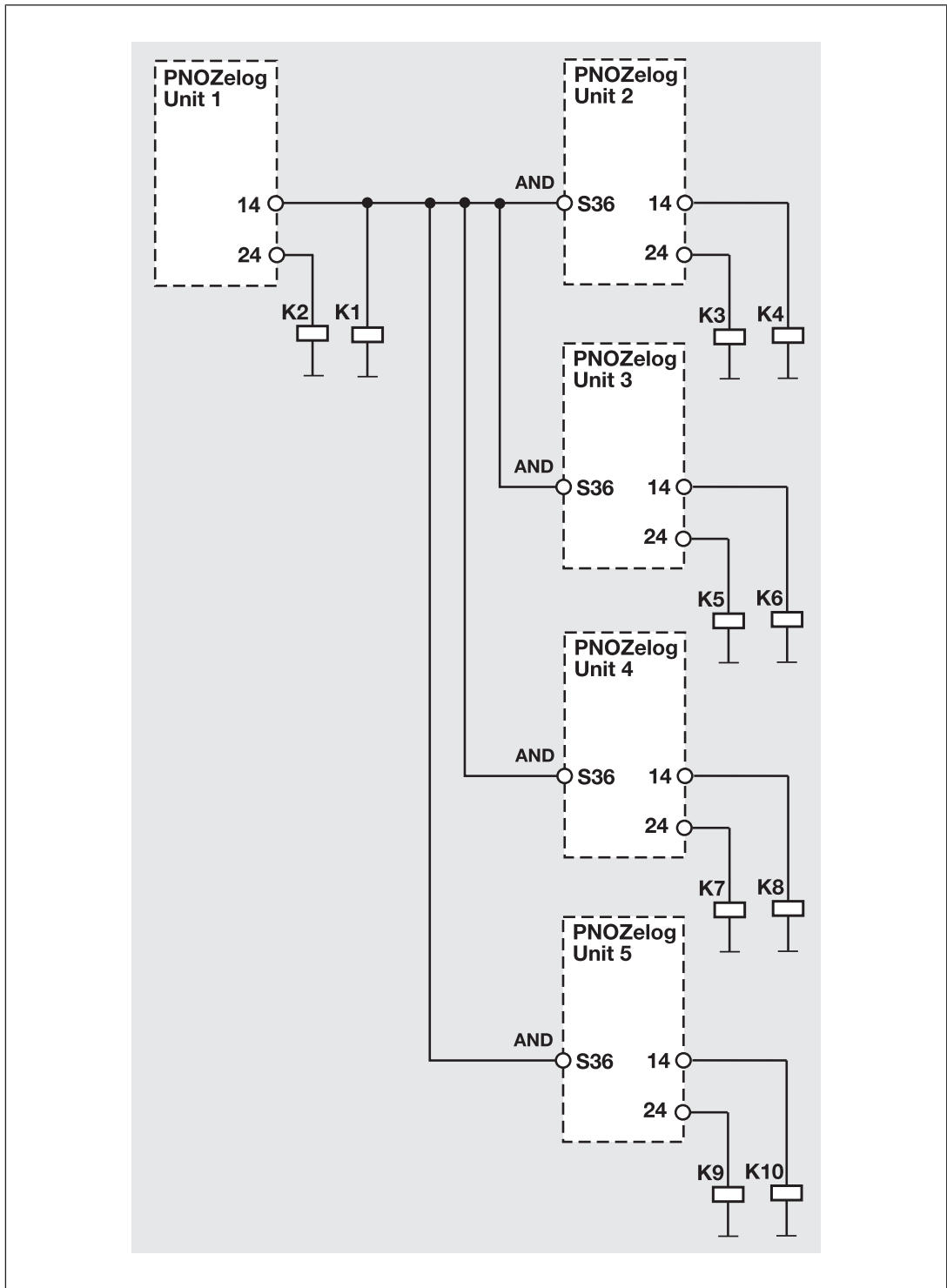

► Example 2:

Loads are connected to the safety outputs of Unit 1. In addition, a safety output is AND-linked to another PNOZelog unit via the logic input S36.

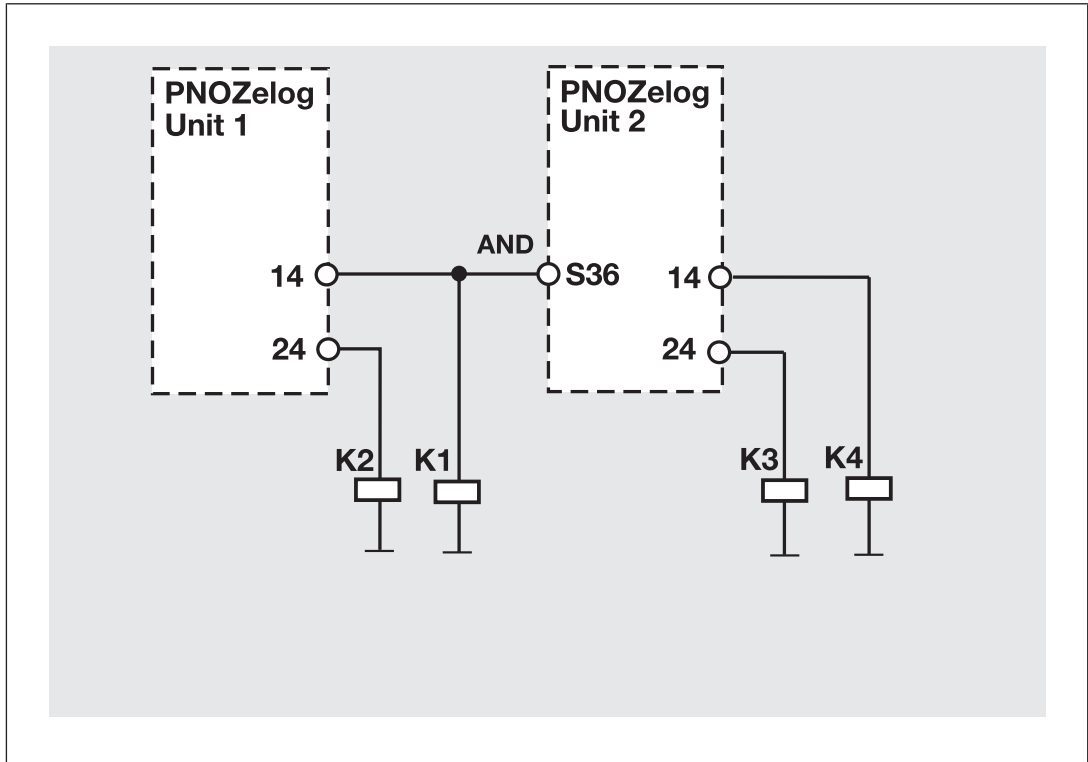

► Example 3

The logic connection line between Unit 1 and Unit 2 contains contacts from the external contactors on Unit 4. This means that Unit 4 and Unit 1 can set the outputs on Unit 2 and Unit 3 to low.

A short circuit between +24 VDC and a safety output must be excluded!

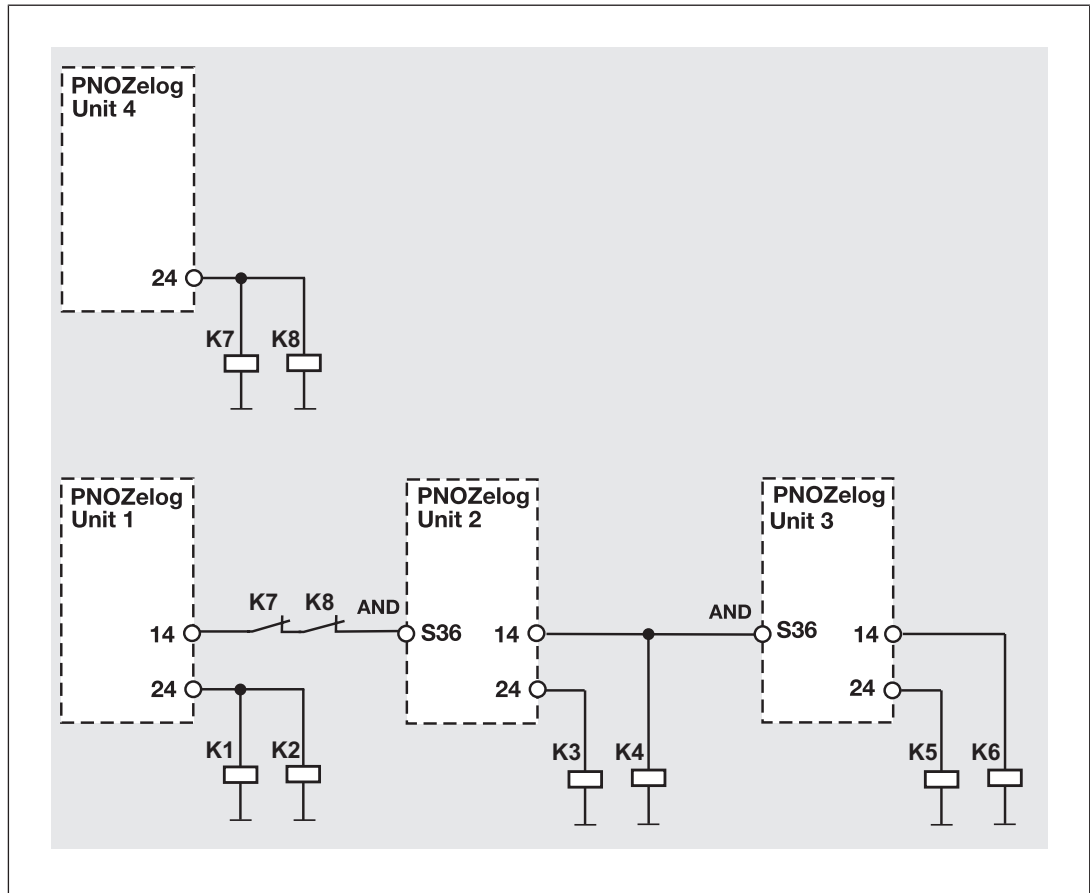

► Example 4

Unit 1 and Unit 2 are OR-linked via Unit 3. If the output from Unit 2 has a low signal, Unit 1 alone will control the status of the outputs on Unit 3. If Unit 2 sends a high signal to the OR input on Unit 3, a high signal will be present at the outputs on Unit 3, irrespective of the status of its input circuit.

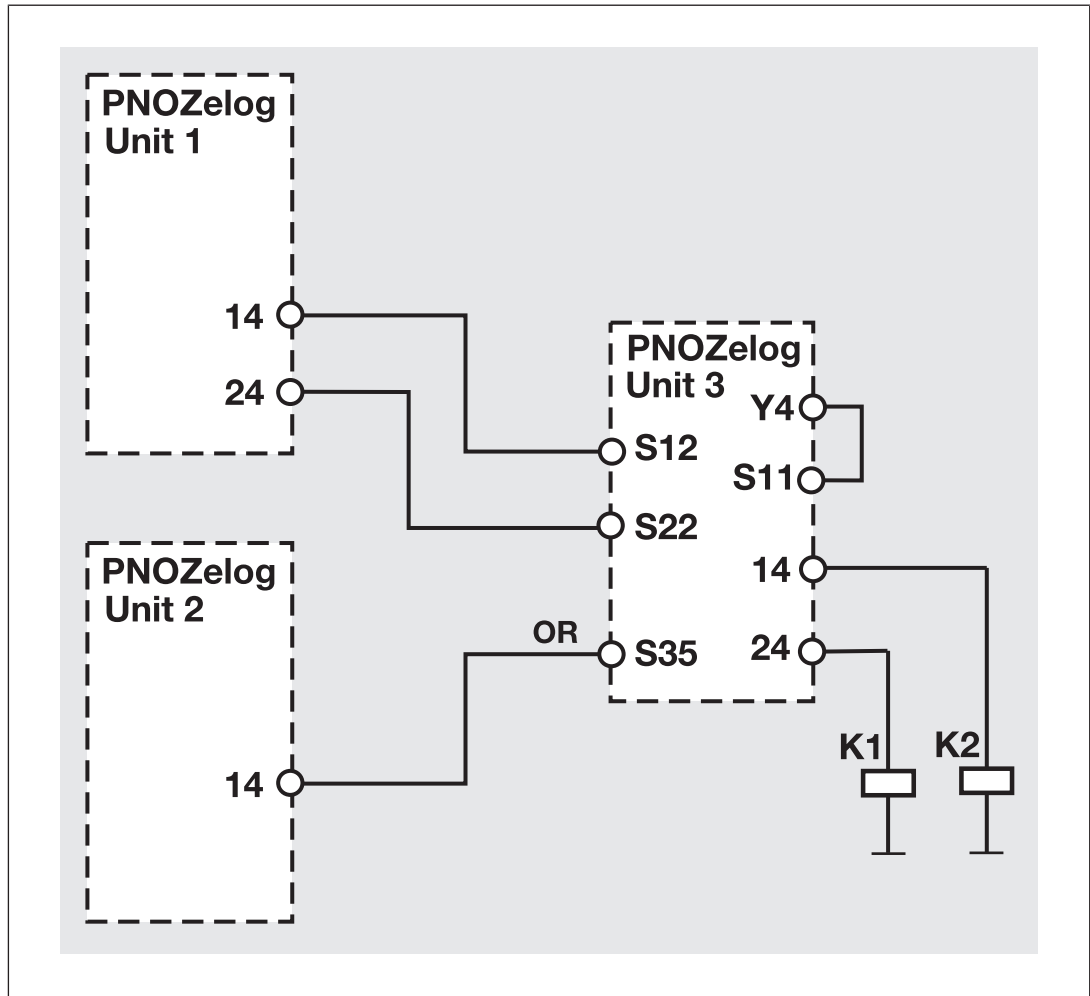

Operation



NOTICE

The safety function should be checked after initial commissioning and each time the plant/machine is changed. The safety functions may only be checked by qualified personnel.



INFORMATION

The safety outputs are constantly checked via test pulses. This may generate a humming noise on the connected contactors, which does not affect the function. The test pulses also mean that, when measured with a multi-meter, the voltage at the safety outputs is displayed to be less than it actually is.

The unit detects the set operating mode once supply voltage is applied. During this time (initialisation phase) the "POWER" LED will flash. The unit is ready for operation when the "POWER" LED is lit continuously.

The operating mode is only detected if the safety mat has not been activated.

LEDs indicate the status and errors during operation:



LED on



LED flashes

Status indicators



POWER

Supply voltage is present, operating mode is detected.



POWER

Initialisation phase



CH.1

There is a high signal at safety output 14.



CH.2

There is a high signal at safety output 24.

Faults - malfunctions

Fault

Fault conditions are indicated by flashing the LEDs. There are faults that are displayed via periodic flashing (see table "Display of fault conditions") and faults where an error code can be determined via the number of flashes (see table "Relationship between the number of flashes and the decimal error code"). These faults are always indicated by three short flashes at LED CH.1 or CH.2. After a longer pause, the LED will then flash at one second intervals. The number of LED flashes corresponds to a digit in the error code. The error code can consist of up to 4 digits. The digits are separated by a longer period without flashing. The entire sequence is constantly repeated.



INFORMATION

Error code 0: 16 flashes



INFORMATION

Supply interruptions lasting longer than 20 ms are detected as an error. The LEDs indicate an error and the safety outputs carry a low signal. The plant or machinery driven via the safety outputs will be shut down. The unit can only be restarted when the supply voltage is switched off for at least 1 s and then switched on again.

Display of fault conditions

LED	Fault	Remedy
LEDs unlit	Supply voltage is missing, too low, wrongly connected	Connect supply voltage: A1 - +24 VDC and A2 - 0 VDC Permitted voltage range: 19.2 ... 30 VDC
POWER flashes	Unknown operating mode, initialisation phase, start not executed	Depending on operating mode: Press start button or perform start-up test
CH.1 or CH.2 flash a code	Error coding, see table "Error code [📖 24]"	See table "Error code [📖 24]"
CH.1 and CH.2 flash alternately	Feedback loop open on start-up	Close feedback loop, restart unit

Examples

Error code 1, 3:

LED CH.1 or CH.2 flashes

- ▶ 3 times, short
- ▶ Pause
- ▶ Once for one second
- ▶ Pause
- ▶ 3 times, for one second each

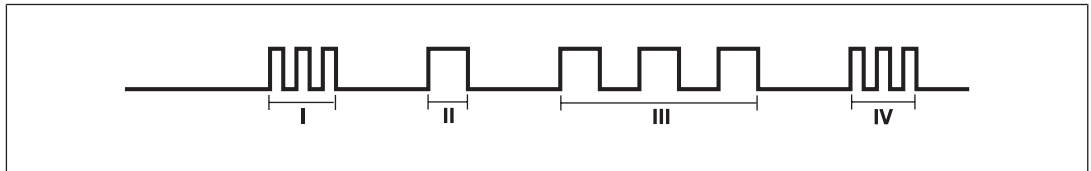

Error code 1:

LED CH.1 or CH.2 flashes

- ▶ 3 times, short
- ▶ Pause
- ▶ Once for one second

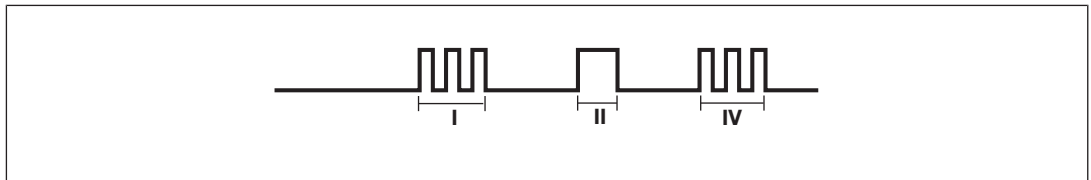

Error code 1, 0:
LED CH.1 or CH.2 flashes

- ▶ 3 times, short
- ▶ Pause
- ▶ Once for one second
- ▶ Pause
- ▶ 16 times, for one second each

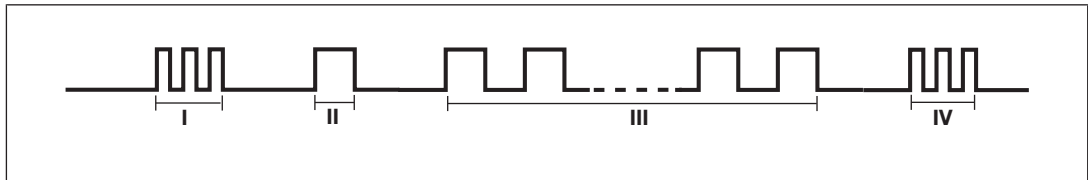

- I Code for error message
- II Code for 1st digit
- III Code for 2nd digit
- IV Code for error message repeated

The table below shows the relationship between the number of flashes and the error code. The key to the error codes is described in the Error coding table.

Number of flashes	1	2	3	4	5	6	7	8	9	10	11	12	13	14	15	16
Decimal error code	1	2	3	4	5	6	7	8	9	10	11	12	13	14	15	0

Error coding

**INFORMATION**

Each time a fault is rectified, switch the supply voltage off for at least 1 s and then switch it back on.

Decimal error code	Number of flashes	Description	Remedy
1	3x short – 1x long – 3x short	Faulty wiring, short circuit	Wiring error at start input, input circuits, feedback loop or programming input
2	3x short – 2x long – 3x short		
3	3x short – 3x long – 3x short		
4	3x short – 4x long – 3x short	In the initialisation phase, short circuit between the safety outputs and +24 VDC	Rectify wiring error at terminals 14, 24
...	...		
9	3x short – 9x long – 3x short		
10	3x short – 10x long – 3x short		
...	...	During operation, short circuit between the safety outputs and +24 VDC	Rectify wiring error at terminals 14, 24
1, 0	3x short – 1x long – 16x long – 3x short		
1, 1	3x short – 1x long – 1x long – 3x short		
1, 9	3x short – 1x long – 9x long – 3x short		
10.1	3x short – 10x long – 1x long – 3x short		
14.5	3x short – 14x long – 5x long – 3x short		
1, 2	3x short – 1x long – 2x long – 3x short		
1, 3	3x short – 1x long – 3x long – 3x short		
1, 12	3x short – 1x long – 12x long – 3x short		
1, 13	3x short – 1x long – 13x long – 3x short		
1, 4	3x short – 1x long – 4x long – 3x short	Operating mode changed during operation	Check wiring for the operating mode and rectify fault

Decimal error code	Number of flashes	Description	Remedy
1, 5	3x short – 1x long – 5x long – 3x short	Unexpected status at S36	Check wiring at terminal S36
1, 6 1, 7	3x short – 1x long – 6x long – 3x short 3x short – 1x long – 7x long – 3x short	Wiring of operating mode “with detection of shorts across contacts” faulty	Rectify wiring error at input circuits
1, 8 1, 11	3x short – 1x long – 8x long – 3x short 3x short – 1x long – 11x long – 3x short	1. Maximum time of feedback loop monitoring exceeded 2. PNOZ e6.1p, PNOZ e6vp: External feedback loop closed, but internal feedback loop faulty	1. Check contactor for contact welding 2. No user remedy possible. Change the unit.
1, 10	3x short – 1x long – 10x long – 3x short	Open circuit	Check safety mat wiring
5, 10	3x short – 5x long – 10x long – 3x short	$U_B < 19.2$ VDC	Keep within the supply voltage range of 19.2 ... 30 VDC
8, 1	3x short – 8x long – 1x long – 3x short	Invalid operating mode	Check wiring for the operating mode and rectify fault
8, 2 8, 3 14, 13	3x short – 8x long – 2x long – 3x short 3x short – 8x long – 3x long – 3x short 3x short – 14x long – 13x long – 3x short	Supply interrupted, possibly caused by a short to earth	Rectify wiring error at terminal A1 or check supply voltage
2, 0, 0 2, 0, 1	3x short – 2x long – 16x long – 16x long – 3x short 3x short – 2x long – 16x long – 1x long – 3x short	$U_B < 19.2$ VDC	Keep within the supply voltage range of 19.2 ... 30 VDC
2, 0, 2	3x short – 2x long – 16x long – 2x long – 3x short	In the initialisation phase, short circuit between the safety outputs and +24 VDC	Rectify wiring error at terminals 14, 24
2, 0, 3	3x short – 2x long – 16x long – 3x long – 3x short	$U_B < 19.2$ VDC	Keep within the supply voltage range of 19.2 ... 30 VDC

Dimensions in mm

* With spring-loaded terminals

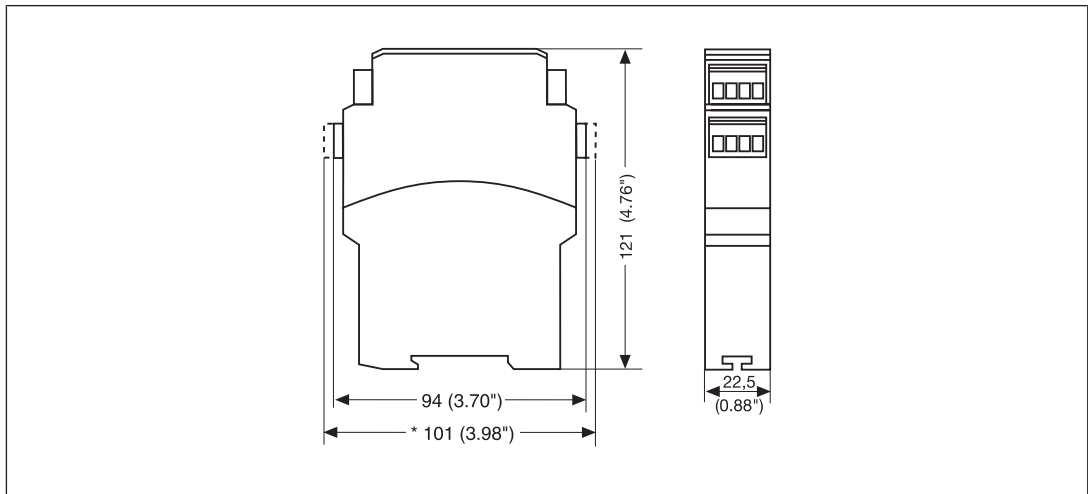

Technical details

General	774180	784180
Certifications	CE, EAC (Eurasian), TÜV, cULus Listed	CE, EAC (Eurasian), TÜV, cULus Listed
Electrical data	774180	784180
Supply voltage		
Voltage	24 V	24 V
Kind	DC	DC
Voltage tolerance	-20 %/+25 %	-20 %/+25 %
Output of external power supply (DC) at no load	2 W	2 W
Residual ripple DC	20 %	20 %
Duty cycle	100 %	100 %
External unit fuse protection F1 max.	6 A slow/10 A quick	6 A slow/10 A quick
Inputs	774180	784180
Voltage at		
Input circuit DC	24 V	24 V
Start circuit DC	24 V	24 V
Feedback loop DC	24 V	24 V
Logic input	24 V	24 V
Current at		
Input circuit DC	5 mA	5 mA
Start circuit DC	5 mA	5 mA
Feedback loop DC	5 mA	5 mA
Logic input	5 mA	5 mA

Inputs	774180	784180
Max. overall cable resistance R _I -max		
Start circuit and feedback loop	2.000 Ohm	2.000 Ohm
Input circuit, dual-channel	150 Ohm	150 Ohm
Max. safety mat resistance	150 Ohm	150 Ohm
Max. line capacitance	450 nF	450 nF
Semiconductor outputs	774180	784180
Overall performance ext. loading, semiconductor	130 W	130 W
Number of safety outputs		
Instantaneous	2	2
Number of auxiliary outputs	1	1
Number of test pulse outputs	2	2
Residual current at "0" signal	4 mA	4 mA
Max. internal voltage drop	1 V	1 V
Switching capability, 2 safety outputs under load		
Current at UB ≤ 26.5 V	2 A	2 A
Current at UB > 26,5 V	1,5 A	1,5 A
Power at UB ≤ 26.5 V	50 W	50 W
Power at UB > 26,5 V	45 W	45 W
Switching capability, 1 safety output under load		
Current at UB ≤ 26.5 V	2,7 A	2,7 A
Current at UB > 26,5 V	2,2 A	2,2 A
Power at UB ≤ 26.5 V	70 W	70 W
Power at UB > 26,5 V	65 W	65 W
Conditional rated short circuit current	100 A	100 A
Lowest operating current	3 mA	3 mA
Utilisation category in accordance with EN 60947-1	DC-12	DC-12
Max. line capacitance at the outputs without load	2 nF	2 nF
Voltage auxiliary and test pulse outputs	24 V	24 V
Current auxiliary and test pulse outputs	0,5 A	0,5 A

Times	774180	784180
Switch-on delay		
After power on	3 s	3 s
With automatic start typ.	50 ms	50 ms
With automatic start max.	180 ms	180 ms
With monitored start typ.	180 ms	180 ms
With monitored start max.	260 ms	260 ms
Logic inputs typ.	120 ms	120 ms
Logic inputs max.	200 ms	200 ms
Response time t_r semiconductor outputs		
typ.	40 ms	40 ms
max.	43 ms	43 ms
Maximum time of feedback loop monitoring		
	150 ms	150 ms
Supply interruption before de-energisation		
	20 ms	20 ms
Simultaneity, channel 1 and 2 max.		
	∞	∞
Environmental data	774180	784180
Climatic suitability		
	EN 60068-2-78	EN 60068-2-78
Ambient temperature		
Temperature range	-10 - 55 °C	-10 - 55 °C
Storage temperature		
Temperature range	-25 - 70 °C	-25 - 70 °C
Climatic suitability		
Humidity	93 % r. h. at 40 °C	93 % r. h. at 40 °C
Condensation during operation		
	Not permitted	Not permitted
EMC		
	EN 60947-5-1, EN 61000-6-2, EN 61000-6-4, EN 61326-3-1	EN 60947-5-1, EN 61000-6-2, EN 61000-6-4, EN 61326-3-1
Vibration		
In accordance with the standard	EN 60068-2-6	EN 60068-2-6
Frequency	10 - 55 Hz	10 - 55 Hz
Amplitude	0,35 mm	0,35 mm
Airgap creepage		
In accordance with the standard	EN 60947-1	EN 60947-1
Overvoltage category	III	III
Pollution degree	2	2
Rated insulation voltage		
	30 V	30 V
Rated impulse withstand voltage		
	0,8 kV	0,8 kV
Protection type		
Housing	IP40	IP40
Terminals	IP20	IP20
Mounting area (e.g. control cabinet)	IP54	IP54
Mechanical data	774180	784180
Mounting position		
	Any	Any

Mechanical data	774180	784180
Material		
Bottom	PPO UL 94 V0	PPO UL 94 V0
Front	ABS UL 94 V0	ABS UL 94 V0
Top	PPO UL 94 V0	PPO UL 94 V0
Connection type	Screw terminal	Spring-loaded terminal
Mounting type	plug-in	plug-in
Conductor cross section with screw terminals		
1 core flexible	0,25 - 2,5 mm², 24 - 12 AWG	–
2 core with the same cross section, flexible with crimp connectors, no plastic sleeve	0,25 - 1 mm², 24 - 16 AWG	–
2 core with the same cross section, flexible without crimp connectors or with TWIN crimp connectors	0,2 - 1,5 mm², 24 - 16 AWG	–
Torque setting with screw terminals	0,5 Nm	–
Stripping length with screw terminals	8 mm	–
Conductor cross section with spring-loaded terminals: Flexible with/without crimp connector	–	0,2 - 1,5 mm², 24 - 16 AWG
Spring-loaded terminals: Terminal points per connection	–	2
Stripping length with spring-loaded terminals	–	8 mm
Dimensions		
Height	94 mm	101 mm
Width	22,5 mm	22,5 mm
Depth	121 mm	121 mm
Weight	125 g	125 g

Where standards are undated, the 2020-07 latest editions shall apply.

Safety characteristic data



NOTICE

You must comply with the safety characteristic data in order to achieve the required safety level for your plant/machine.

Operating mode	EN ISO 13849-1: 2015 PL	EN ISO 13849-1: 2015 Category	EN 62061 SIL CL	EN 62061 PFH _D [1/h]	IEC 61511 SIL	IEC 61511 PFD	EN ISO 13849-1: 2015 T _M [year]
SC output via logic input	PL e	Cat. 4	SIL CL 3	3,61E-09	SIL 3	5,82E-05	20
SC output via safety mat	PL d	Cat. 3	SIL CL 2	3,68E-09	SIL 2	6,29E-05	20

Explanatory notes for the safety-related characteristic data:

- ▶ The SIL CL value in accordance with EN 62061 corresponds to the SIL value in accordance with EN 61508.
- ▶ T_M is the maximum mission time in accordance with EN ISO 13849-1. The value also applies as the retest interval in accordance with EN 61508-6 and IEC 61511 and as the proof test interval and mission time in accordance with EN 62061.

All the units used within a safety function must be considered when calculating the safety characteristic data.



INFORMATION

A safety function's SIL/PL values are **not** identical to the SIL/PL values of the units that are used and may be different. We recommend that you use the PAScal software tool to calculate the safety function's SIL/PL values.

Remove plug-in terminals

Procedure: Insert the screwdriver into the housing recess behind the terminal and lever the terminal out.

Do **not** remove the terminals by pulling the cables!

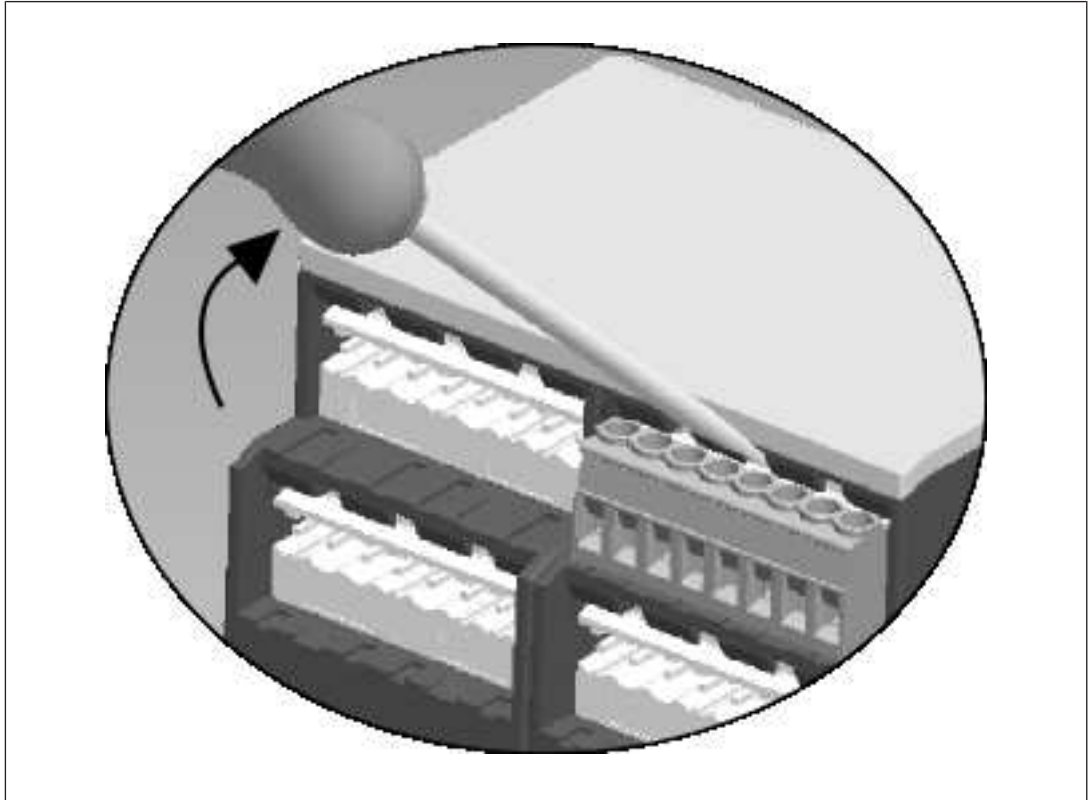

Order reference

Product

Product type	Features	Connection type	Order no.
PNOZ e4.1p	24 V DC	Screw terminals	774180
PNOZ e4.1p C	24 V DC	Spring-loaded terminals	784180

Accessories

Product type	Features	Order no.
Terminal block filter 1	Terminal block with filter for 3-10 kOhm load range	774195
Terminal block filter 2	Terminal block with filter for 10-30 kOhm load range	774196

► Support

Technical support is available from Pilz round the clock.

Americas

Brazil
+55 11 97569-2804

Canada
+1 888 315 7459

Mexico
+52 55 5572 1300

USA (toll-free)
+1 877-PILZUSA (745-9872)

Asia

China
+86 21 60880878-216

Japan
+81 45 471-2281

South Korea
+82 31 778 3300

Australia

+61 3 95600621

Europe

Austria
+43 1 7986263-0

Belgium, Luxembourg
+32 9 3217570

France
+33 3 88104003

Germany
+49 711 3409-444

Ireland
+353 21 4804983

Italy, Malta
+39 0362 1826711

Scandinavia

+45 74436332

Spain

+34 938497433

Switzerland

+41 62 88979-32

The Netherlands

+31 347 320477

Turkey

+90 216 5775552

United Kingdom

+44 1536 462203

You can reach our international hotline on:

+49 711 3409-444
support@pilz.com

Pilz develops environmentally-friendly products using ecological materials and energy-saving technologies. Offices and production facilities are ecologically designed, environmentally-aware and energy-saving. So Pilz offers sustainability, plus the security of using energy-efficient products and environmentally-friendly solutions.

Energy
saving by Pilz



We are represented internationally. Please refer to our homepage www.pilz.com for further details or contact our headquarters.

Headquarters: Pilz GmbH & Co. KG, Felix-Wankel-Straße 2, 73760 Ostfildern, Germany
Telephone: +49 711 3409-0, Telefax: +49 711 3409-133, E-Mail: info@pilz.com, Internet: www.pilz.com

PILZ
THE SPIRIT OF SAFETY

21362-EN-07, 2020-12 Printed in Germany
© Pilz GmbH & Co. KG, 2019

CECC® , CHRE® , CMSE® , InduraNET p® , Leansafe® , Master of Safety® , Master of Security® , PAS4000® , PAScall® , PASconfig® , Pilz® , PTT® , PLID® , PMCPirimo® , PMCPiritego® , PMCTendo® , PMD® , PMJ® , PNOZ® , PRBT® , PRCM® , PRCM® , PSS® , PVS® , SafetyBUS p® , SafetyNET p® , THE SPIRIT OF SAFETY® are registered and protected trademarks of Pilz GmbH & Co. KG in some countries. We would point out that product features may vary from the details stated in this document, depending on the status at the time of publication and the scope of the equipment. We accept no responsibility for the validity, accuracy and entirety of the text and graphics presented in this information. Please contact our Technical Support if you have any questions.