

► PNOZ m B0

PILZ
THE SPIRIT OF SAFETY

Operating Manual-1002660-EN-11

- Configurable, safe small controllers PNOZmulti 2



This document is the original document.

Where unavoidable, for reasons of readability, the masculine form has been selected when formulating this document. We do assure you that all persons are regarded without discrimination and on an equal basis.

All rights to this documentation are reserved by Pilz GmbH & Co. KG. Copies may be made for the user's internal purposes. Suggestions and comments for improving this documentation will be gratefully received.

Pilz®, PIT®, PMI®, PNOZ®, Primo®, PSEN®, PSS®, PVIS®, SafetyBUS p®, SafetyEYE®, SafetyNET p®, the spirit of safety® are registered and protected trademarks of Pilz GmbH & Co. KG in some countries.



SD means Secure Digital

1	Introduction	5
1.1	Validity of documentation	5
1.2	Using the documentation	5
1.3	Definition of symbols	5
2	Overview	7
2.1	Range	7
2.2	Unit features	7
2.3	Chip card	8
2.4	Front view	9
3	Safety	10
3.1	Intended use	10
3.2	Applicable documentation	11
3.3	System requirements	11
3.4	Safety regulations	11
3.4.1	Safety assessment	11
3.4.2	Use of qualified personnel	12
3.4.3	Warranty and liability	12
3.4.4	Disposal	12
3.4.5	For your safety	12
4	Security	13
4.1	Required security measures	13
5	Function description	14
5.1	Integrated protection mechanisms	14
5.2	Functions	14
5.3	System reaction time	14
5.4	Block diagram	14
5.5	Diagnostics	15
6	Installation	16
6.1	Control cabinet installation	16
6.1.1	Mounting distances	17
6.2	Dimensions in mm	18
6.3	Install base unit without expansion module	18
6.4	Connecting the base unit and expansion modules	19
7	Commissioning	20
7.1	General wiring guidelines	20
7.2	Connection	20
7.3	Load project from chip card	23
7.4	Load project via USB port	23
7.5	Function test during commissioning	24
7.6	Using the chip card	24
7.7	Connection example	25

8	Operation	26
8.1	LED indicators	26
8.2	Display indicators	27
8.2.1	Rotary knob	29
8.2.1.1	Function	29
8.2.1.2	Pull out and retract the knob	29
8.2.1.3	Rotate and press the knob	29
8.2.2	Switch between menu levels	30
8.2.3	Unit diagnostics on the LC display	31
8.2.4	Error stack on the LC display	32
9	Maintenance and testing	33
10	Technical details	34
10.1	Safety characteristic data	38
10.2	Classification according to ZVEI, CB24I	39
11	Supplementary data	40
11.1	Maximum capacitive load C (μF) with load current I (A) at the semiconductor outputs	40
11.2	Maximum permitted total current of the semiconductor outputs	40
11.3	Maximum permitted humidity	41
11.3.1	Max. relative humidity, operation	41
11.3.2	Max. relative humidity, storage	41
12	Order reference	42
12.1	Product	42
12.2	Accessories	42
12.2.1	Chip card	42
12.2.2	Replacement terminals	42
12.2.3	Cable	42
12.2.4	Terminating plug	42
13	EC declaration of conformity	43
14	UKCA-Declaration of Conformity	44

1 Introduction

1.1 Validity of documentation

This documentation is valid for the product PNOZ m B0 from Version 2.6.

This operating manual explains the function and operation, describes the installation and provides guidelines on how to connect the product.

1.2 Using the documentation

This document is intended for instruction. Only install and commission the product if you have read and understood this document. The document should be retained for future reference.

1.3 Definition of symbols

Information that is particularly important is identified as follows:



DANGER!

This warning must be heeded! It warns of a hazardous situation that poses an immediate threat of serious injury and death and indicates preventive measures that can be taken.



WARNING!

This warning must be heeded! It warns of a hazardous situation that could lead to serious injury and death and indicates preventive measures that can be taken.



CAUTION!

This refers to a hazard that can lead to a less serious or minor injury plus material damage, and also provides information on preventive measures that can be taken.



NOTICE

This describes a situation in which the product or devices could be damaged and also provides information on preventive measures that can be taken. It also highlights areas within the text that are of particular importance.



INFORMATION

This gives advice on applications and provides information on special features.

2 Overview

2.1 Range

- ▶ Base unit PNOZ m B0
- ▶ 2 terminators

2.2 Unit features

Application of the product PNOZ m B0:

Base unit of the configurable control system PNOZmulti 2

The product has the following features:

- ▶ Can be configured in the PNOZmulti Configurator
- ▶ Semiconductor outputs:
 - 4 safety outputs
depending on the application, up to PL e of EN ISO 13849-1 and up to SIL 3 of EN IEC 62061
- ▶ 12 safe inputs for connecting, for example:
 - Emergency stop pushbuttons
 - Two-hand pushbuttons
 - Safety gate limit switches
 - Start buttons
 - Light barriers
 - Scanner
 - Enabling switches
 - PSEN
 - Operating mode selector switches
- ▶ 8 configurable inputs/outputs
 - Can be configured as:
 - Safe inputs (see above for connection options)
 - or
 - Auxiliary outputs
- ▶ 4 configurable outputs
 - Can be configured as:
 - Auxiliary outputs
 - or
 - Test pulse outputs

- ▶ LED display for:
 - Error messages
 - Diagnostics
 - Supply voltage
 - Fault at the outputs
 - Fault at the inputs
- ▶ Backlit display for:
 - Error messages
 - State of supply voltage
 - State of the inputs and outputs
 - Status information
 - Device information
- ▶ Test pulse outputs used to monitor shorts across the inputs
- ▶ Monitoring of shorts between the safety outputs
- ▶ Plug-in connection terminals:
Either spring-loaded terminal or screw terminal available as accessories (see Order references)
- ▶ Rotary knob for menu control
- ▶ Expansion modules can be connected
(please refer to the document "PNOZmulti System Expansion" for details of the type and number that can be connected)

2.3 Chip card

To be able to use the product you will need a chip card.

Chip cards are available with memories of 8 kByte and 32 kByte. For large-scale projects we recommend the 32 kByte chip card (see Technical Catalogue: Accessories chapter).

2.4 Front view

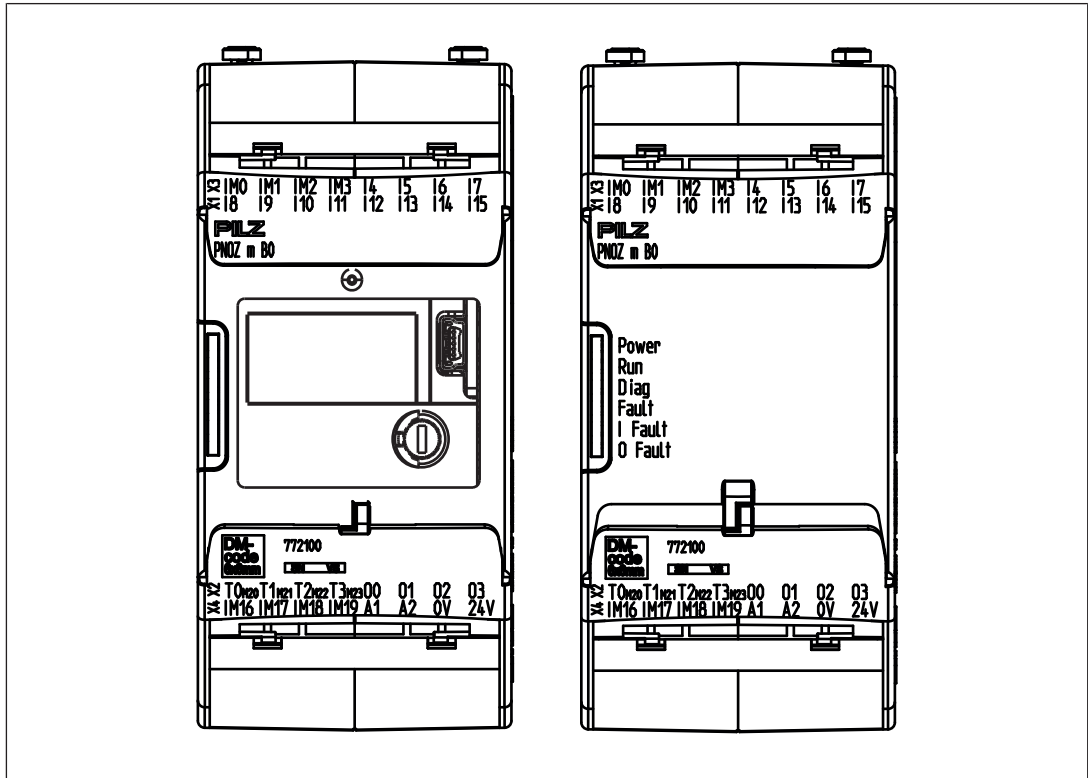

Fig.: Front view with and without cover

Legend

- X1: Inputs I8 ... I15
- X2: Configurable test pulse/auxiliary outputs T0M20 ... T3M23
Semiconductor outputs O0 ... O3
- X3: Configurable inputs/outputs IM0 – IM3
Inputs I4 ... I7
- X4: Configurable inputs/outputs IM16 – IM19
Supply connections
- LEDs: PWR
RUN
DIAG
FAULT
I FAULT
O FAULT

3 Safety

3.1 Intended use

The configurable system PNOZmulti 2 is used for the safety-related interruption of safety circuits and is designed for use in:

- ▶ Emergency stop equipment
- ▶ Safety circuits in accordance with VDE 0113 Part 1 and EN 60204-1



CAUTION!

Inputs and outputs for standard functions must not be used for safety-related applications.

Lifts Directive

The product PNOZ m B0 can be used as a PESSRAL (programmable electronic system in safety-related applications for lifts) in accordance with the Lifts Directive 2014/33/EU. It meets the requirements for passenger and goods lifts in accordance with EN 81-1/2, EN 81-20, EN 81-22 and EN 81-50, as well as the requirements for escalators and moving walks in accordance with EN 115-1.

The safety controller should be installed in a protected environment that meets at least the requirements of pollution degree 2.

Example: Protected inside space or control cabinet with protection type IP54 and appropriate air conditioning.

Use in furnaces

The product PNOZ m B0 can be used in furnaces in accordance with EN 298.

Please note:

- ▶ To protect against transient power failures (EN 61000-4-11) the AC power supply used for the system must provide secondary buffering for 20 ms.
- ▶ If the system is used in a DC network, sufficient overvoltage protection must be ensured. Use external protection elements for overvoltage protection that fulfil at least the following properties:
Installation class 4 / test level 4 in accordance with EN 61000-4-5 (4 kV 1.2/50 µs)

Year of manufacture

The year of manufacture is specified on the product after the reference YOM (Year of Manufacturing).

Improper use

The following is deemed improper use in particular

- ▶ Any component, technical or electrical modification to the product,
- ▶ Use of the product outside the areas described in this operating manual,
- ▶ Use of the product outside the technical details (see [Technical details](#)  34]).

**NOTICE****EMC-compliant electrical installation**

The product is designed for use in an industrial environment. The product may cause interference if installed in other environments. If installed in other environments, measures should be taken to comply with the applicable standards and directives for the respective installation site with regard to interference.

3.2 Applicable documentation

This document includes only part of the information required for the use of the device. To understand and correctly use the product you must read further documents.

Please read the following documents:

- ▶ "PNOZmulti Safety Manual"
- ▶ "PNOZmulti Installation Manual"
- ▶ The advanced functions of the device are described in the online help for the PNOZmulti Configurator, in the "PNOZmulti Communication Interfaces" document and in "PNOZmulti Special Applications". Only use these functions once you have read and understood the documentation.
- ▶ For details of the modules that can be connected and the system's reaction times, please refer to the document "PNOZmulti System Expansion".

3.3 System requirements

Please refer to the "Product Modifications" document in the "Version overview" section for details of which versions of the PNOZmulti Configurator can be used for this product.

3.4 Safety regulations

3.4.1 Safety assessment

Before using a device, a safety assessment in accordance with the Machinery Directive is required.

The product as an individual component fulfils the functional safety requirements in accordance with EN ISO 13849 and EN 62061. However, this does not guarantee the functional safety of the overall plant/machine. To achieve the relevant safety level of the overall plant/machine's required safety functions, each safety function needs to be considered separately.

3.4.2 Use of qualified personnel

The products may only be assembled, installed, programmed, commissioned, operated, maintained and decommissioned by persons who are competent to do so.

A competent person is a qualified and knowledgeable person who, because of their training, experience and current professional activity, has the specialist knowledge required. To be able to inspect, assess and operate devices, systems and machines, the person has to be informed of the state of the art and the applicable national, European and international laws, directives and standards.

It is the company's responsibility only to employ personnel who

- ▶ Are familiar with the basic regulations concerning health and safety / accident prevention,
- ▶ Have read and understood the information provided in the section entitled Safety
- ▶ Have a good knowledge of the generic and specialist standards applicable to the specific application.

3.4.3 Warranty and liability

All claims to warranty and liability will be rendered invalid if

- ▶ The product was used contrary to the purpose for which it is intended,
- ▶ Damage can be attributed to not having followed the guidelines in the manual,
- ▶ Operating personnel are not suitably qualified,
- ▶ Any type of modification has been made (e.g. exchanging components on the PCB boards, soldering work etc.).

3.4.4 Disposal

- ▶ In safety-related applications, please comply with the mission time T_M in the safety-related characteristic data.
- ▶ When decommissioning, please comply with local regulations regarding the disposal of electronic devices (e.g. Electrical and Electronic Equipment Act).

3.4.5 For your safety

The unit meets all the necessary conditions for safe operation. However, you should always ensure that the following safety requirements are met:

- ▶ This operating manual only describes the basic functions of the unit. Advanced functions are described in the online help for the PNOZmulti Configurator, in the "PNOZmulti Communication Interfaces" document and in "PNOZmulti Special Applications". Only use these functions once you have read and understood the documentation.
- ▶ Please note the "PNOZmulti Installation Manual".
- ▶ You must note the information stated in the "PNOZmulti Safety Manual".
- ▶ Adequate protection must be provided for all inductive consumers.
- ▶ Do not open the housing or make any unauthorised modifications.
- ▶ Please make sure you shut down the supply voltage when performing maintenance work (e.g. exchanging contactors).

4 Security

To secure plants, systems, machines and networks against cyberthreats it is necessary to implement (and continuously maintain) an overall industrial security concept that is state of the art.

Perform a risk assessment in accordance with VDI/VDE 2182 or IEC 62443-3-2 and plan the security measures with care. If necessary, seek advice from Pilz Customer Support.

4.1 Required security measures

- ▶ The product is not protected from physical manipulation or from reading of memory contents during physical access. Use appropriate measures to ensure that there is no physical access by unauthorised persons. You should also use security seals so that you can detect any manipulation of the product or interfaces. Installation inside a lockable control cabinet is recommended as a minimum measure.
- ▶ The product can be incorporated into a machine network using the expansion module PNOZ m ES ETH. Protect the product from unauthorised data exchange via the network by using a firewall or providing other appropriate measures. Only allow the data exchange that's required for the application. Any data exchange that is not required for the application must be prevented by the firewall.
- ▶ Check the product's log for unauthorised program changes on a regular basis.
- ▶ Modbus/TCP has no security mechanisms. Use a firewall to protect the product from unauthorised access.

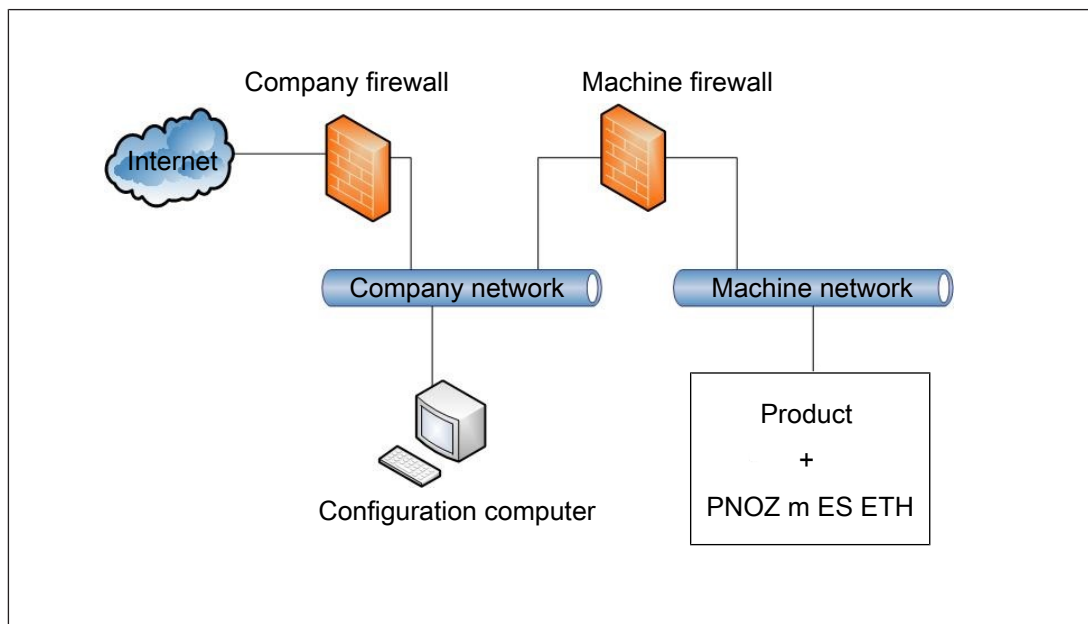

Fig.: Example network topology

- ▶ Note the network data for risk analysis and the security measures.
- ▶ Protect the configuration and log data from unauthorised changes.
- ▶ Delete or destroy the chip card before disposing of the product.

5 Function description

5.1 Integrated protection mechanisms

The relay meets the following safety requirements:

- ▶ The circuit is redundant with built-in self-monitoring.
- ▶ The safety device remains effective in the case of a component failure.
- ▶ The safety outputs are tested periodically using a disconnection test.

5.2 Functions

The function of the inputs and outputs on the control system depends on the safety circuit created using the PNOZmulti Configurator. A chip card is used to download the safety circuit to the base unit. The base unit has 2 microcontrollers that monitor each other. They evaluate the input circuits on the base unit and expansion modules and switch the outputs on the base unit and expansion modules accordingly.

The LEDs on the base unit and expansion modules indicate the status of the configurable control system PNOZmulti.

The online help on the PNOZmulti Configurator contains descriptions of the operating modes and all the functions of the control system, plus connection examples.

5.3 System reaction time

Calculation of the maximum reaction time between an input switching off and a linked output in the system switching off is described in the document "PNOZmulti System Expansion".

5.4 Block diagram

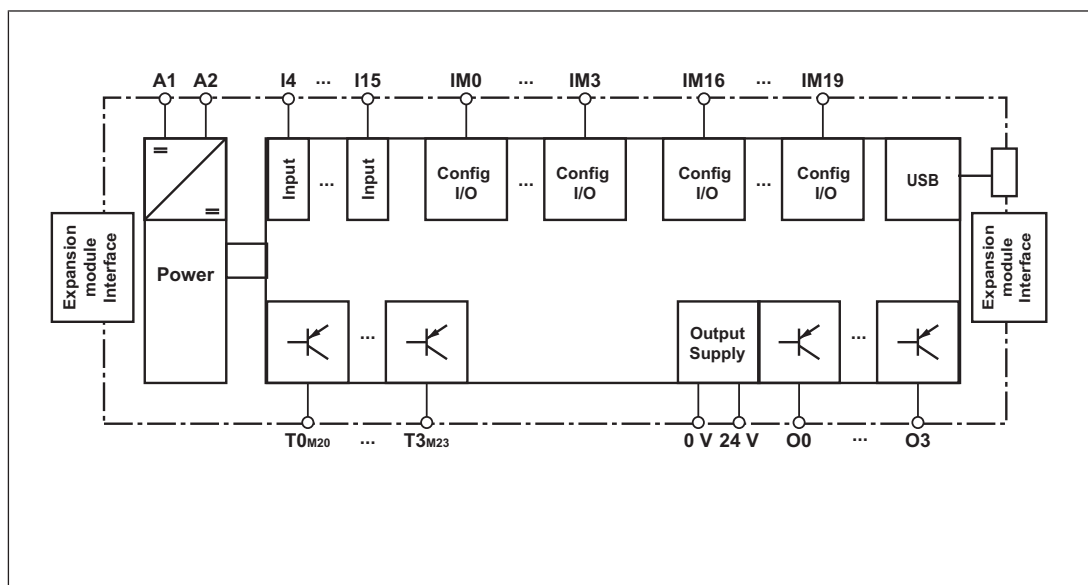

5.5 **Diagnostics**

The status and error messages displayed by the LEDs are saved in an error stack. This error stack can be shown on the display or can be read from the PNOZmulti Configurator via the USB port.

6 Installation

6.1 Control cabinet installation

- ▶ The unit should be installed in a control cabinet with a protection type of at least IP54.
- ▶ Install the system vertically on to a horizontal mounting rail. The venting slots must face upward and downward. Other mounting positions could damage the safety system.
- ▶ Use the locking elements on the rear of the unit to attach it to a mounting rail.
- ▶ In environments exposed to heavy vibration, the unit should be secured using a fixing element (e.g. retaining bracket or end angle).
- ▶ Open the locking slide before lifting the unit from the mounting rail.
- ▶ To comply with EMC requirements, the mounting rail must have a low impedance connection to the control cabinet housing.



NOTICE

Damage due to electrostatic discharge!

Electrostatic discharge can damage components. Ensure against discharge before touching the product, e.g. by touching an earthed, conductive surface or by wearing an earthed armband.

6.1.1 Mounting distances

With control cabinet installation it is essential to maintain a certain distance from the top and bottom, as well as to other heat-producing devices (see diagram). The values stated for the mounting distances are minimum specifications.

The ambient temperature in the control cabinet must not exceed the figure stated in the technical details. Air conditioning may otherwise be required.

Mounting distances:

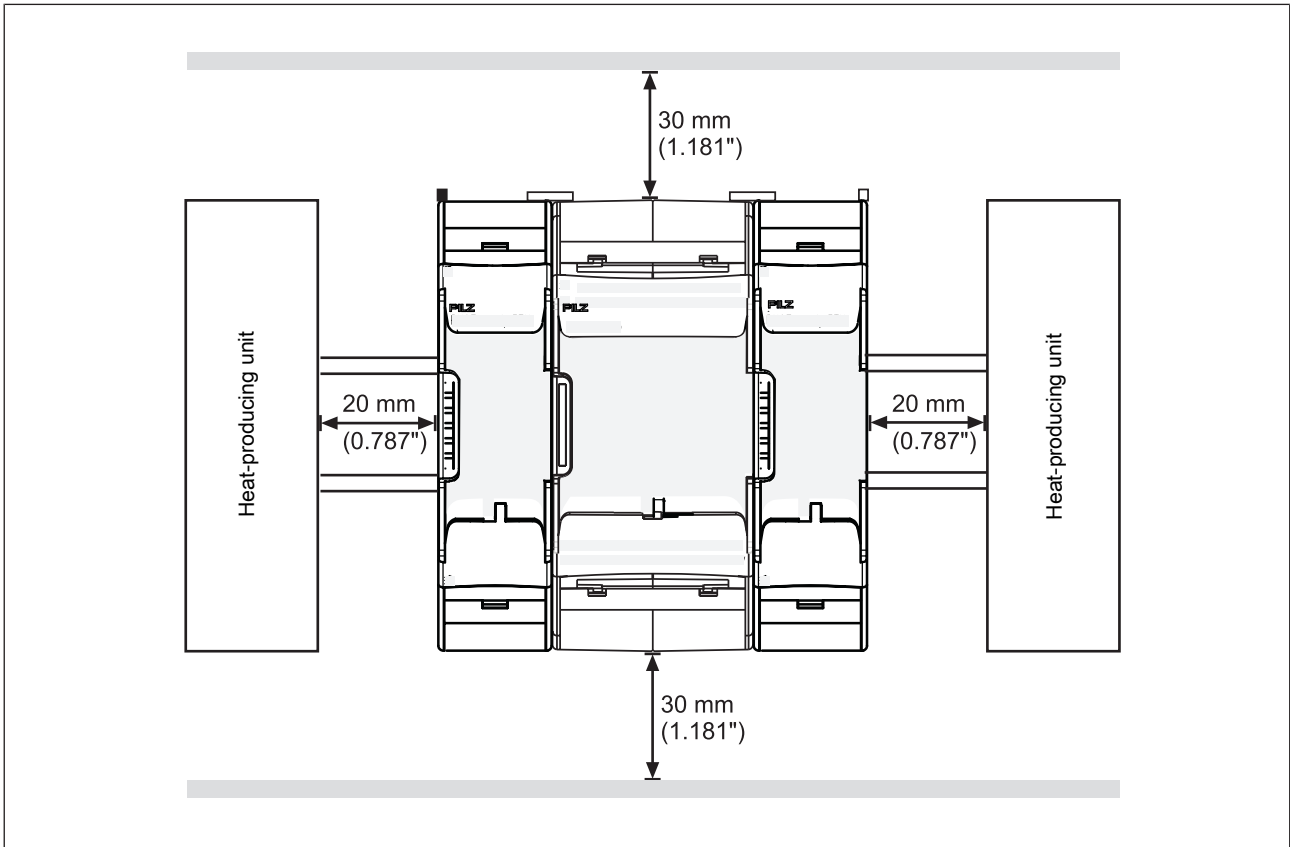

INFORMATION

Please note that at the stated minimum distance, it will be difficult to swap the chip card from above. If you cannot leave a greater distance, remove the unit from the mounting rail to swap the chip card.

6.2 Dimensions in mm

*with spring-loaded terminals

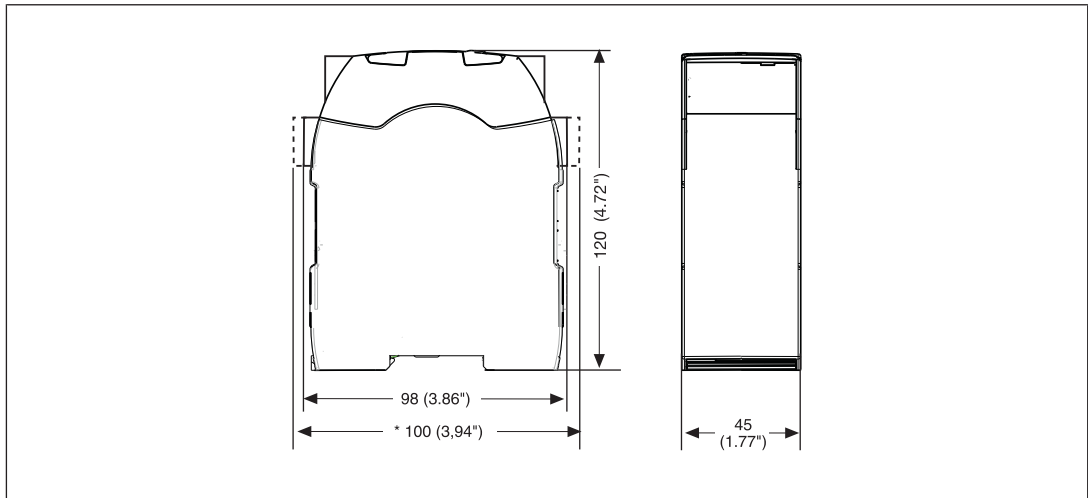

6.3 Install base unit without expansion module

Make sure that the terminators are inserted on the top left and right of the unit.

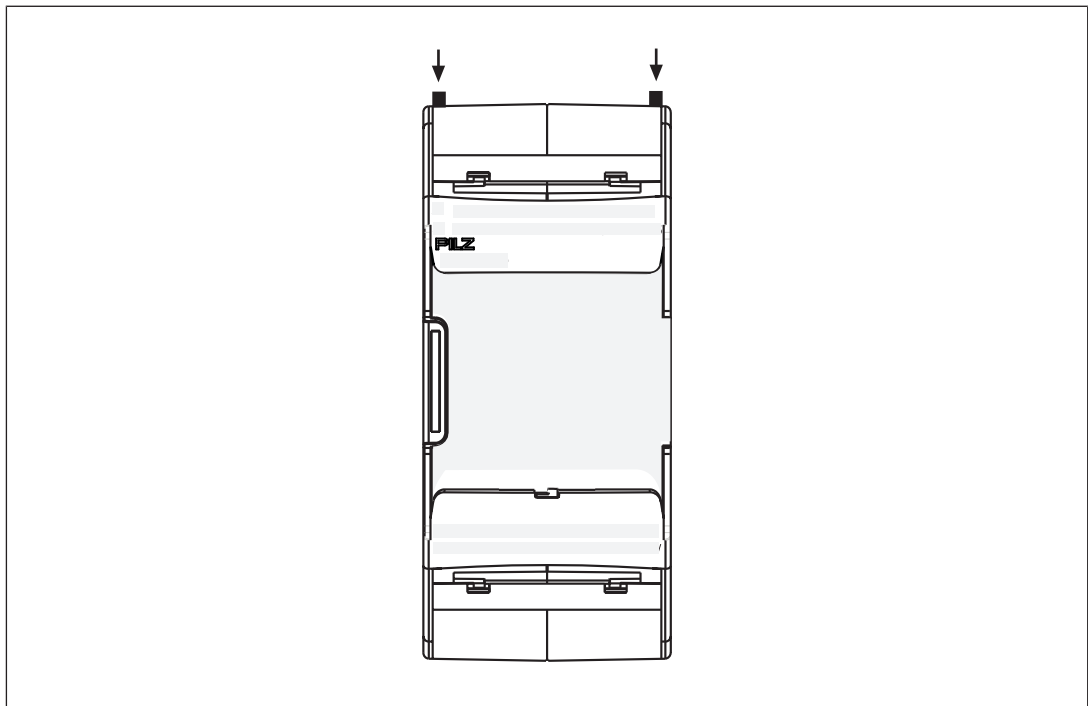

6.4 Connecting the base unit and expansion modules

The position of the expansion modules is defined in the PNOZmulti Configurator. The expansion modules are connected to the left or right of the base unit, depending on the type.

Please refer to the document "PNOZmulti System Expansion" for details of the number of modules that can be connected to the base unit and the module types.



CAUTION!

Please note:

Only connect the expansion modules on the slot stated in the document "System expansion", otherwise the expansion module may be destroyed as a result.

The modules are linked via jumpers.

- ▶ Remove the terminator on the side of the base unit and on the expansion module.
- ▶ Install the base unit and expansion modules on the mounting rail in the order configured in the PNOZmulti Configurator and connect the units using the jumper supplied.
- ▶ Fit the terminator to the unconnected interfaces on the base unit and expansion module.

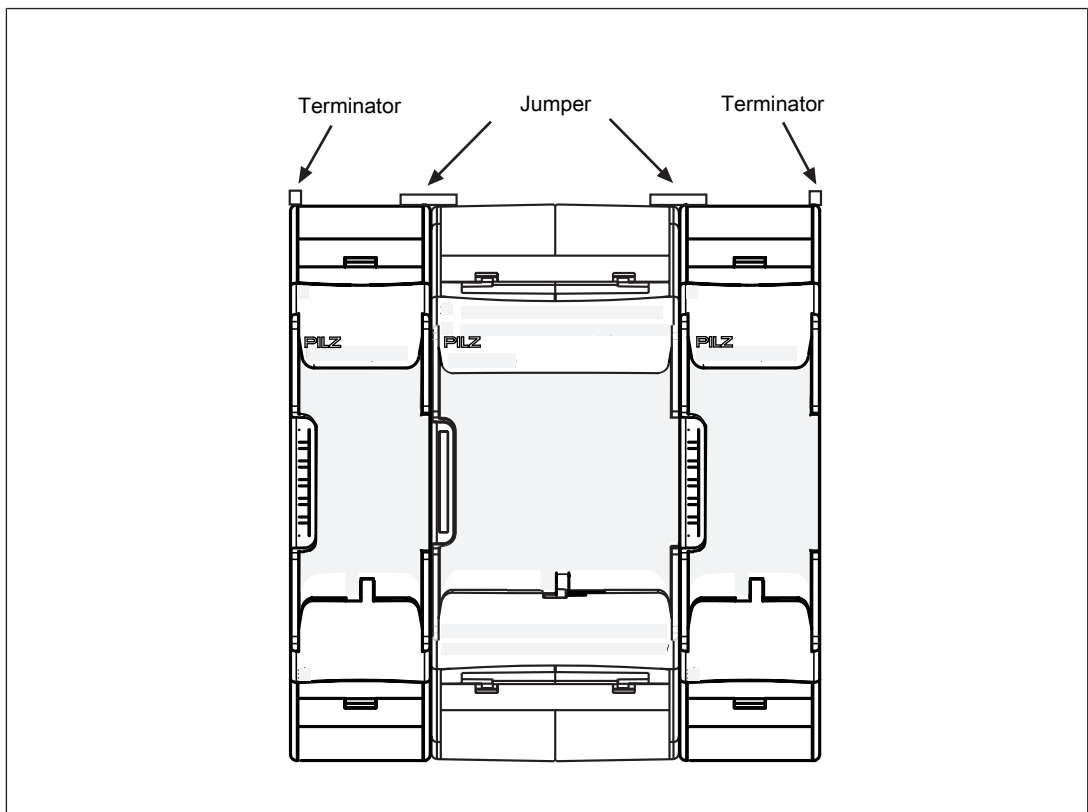

CAUTION!

Only connect the base unit and expansion modules when the supply voltage is switched off.

7 Commissioning

7.1 General wiring guidelines

The wiring is defined in the circuit diagram in the Configurator. There you can select the inputs that are to perform a safety function and the outputs that are to switch this safety function.

Note:

- ▶ Information given in the [Technical details \[34\]](#) must be followed.
- ▶ Outputs O0 to O3 are semiconductor outputs
- ▶ Use copper wiring with a temperature stability of 75 °C.
- ▶ Sufficient fuse protection must be provided on all output contacts with inductive loads.
- ▶ The safety system and input circuits must always be supplied by a single power supply. The power supply must meet the regulations for extra low voltages with protective separation (SELV/PELV).
- ▶ Test pulse outputs must exclusively be used to test the inputs. They must not be used to drive loads.
Do not route the test pulse cables together with actuator cables within an unprotected sheathed cable.

7.2 Connection

Procedure:

- ▶ Wire the inputs and outputs on the base unit in accordance with the circuit diagram.
- ▶ Connect the supply voltage:
 - Supply voltage for the control system:
 - Terminal A1: + 24 VDC
 - Terminal A2: 0 V
 - Supply voltage for the semiconductor outputs:
 - 24 V terminal: + 24 VDC
 - 0V terminal: 0 V

Please note: The supply voltage for the semiconductor outputs must always be present, even if you are not using the semiconductor outputs.

When the voltages are fed separately using two power supplies, the supply voltage for the control system and the supply voltage for the semiconductor outputs are galvanically isolated.



CAUTION!

Do not connect or disconnect expansion modules and terminators during operation.

Supply voltage

Separate power supplies for the supply voltage to the control system and the supply voltage to the semiconductor outputs

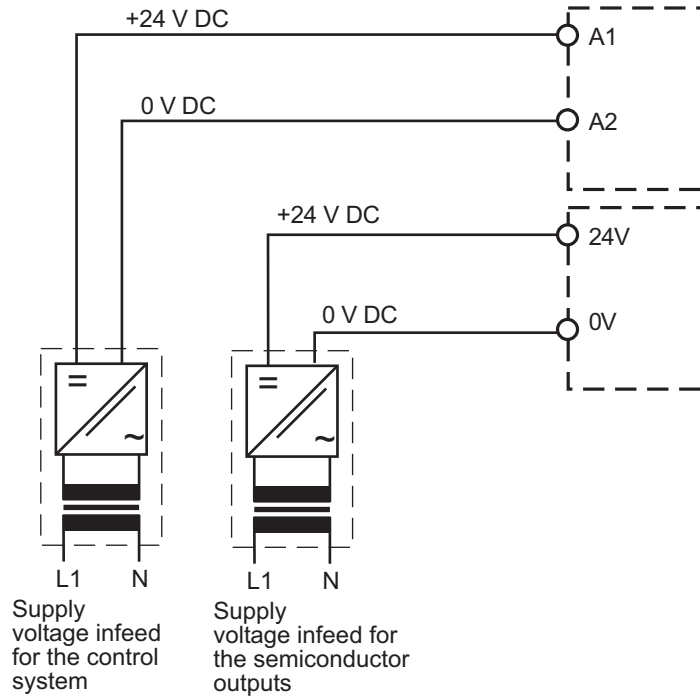

Common power supply for the supply voltage to the control system and the supply voltage to the semiconductor outputs

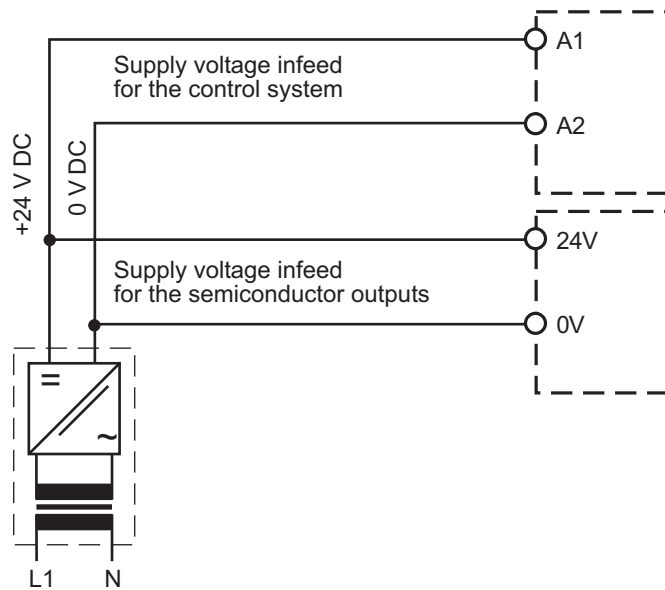

Input circuit	Single-channel	Dual-channel
Emergency stop without detection of shorts across contacts		
Emergency stop with detection of shorts across contacts		
Start circuit	Input circuit without detection of shorts across contacts	Input circuit with detection of shorts across contacts
Semiconductor outputs		
Redundant output		
Single output		

Semiconductor outputs		
Single output with advanced fault detection*		

*Two loads may be connected to each safety output with advanced fault detection, even on applications in accordance with EN IEC 62061, SIL 3. Prerequisite: Feedback loop is connected, shorts across contacts and external power sources are excluded (e.g. through separate multicore cables). Please note that, in the event of an error in the feedback loop, the safety system switches to a safe state and shuts down **all** the outputs.

Feedback loop	Redundant output
Contacts from external contactors	

7.3 Load project from chip card

Procedure:

- ▶ Insert the chip card containing the current project into the card slot on the base unit.
- ▶ Switch on the supply voltage. The LC display shows the project name, CRC sum and the date the project was created. Please check this information.
- ▶ Load the project by pressing the rotary knob. For the project to be downloaded, the rotary knob must be held down for between 3 and 8 seconds. Once the project has been successfully downloaded, the status of the inputs and outputs will be shown on the display.

7.4 Load project via USB port

Procedure:

- ▶ Insert a chip card into the card slot on the base unit.
- ▶ Connect the computer containing the PNOZmulti Configurator to the base unit via the USB port.
- ▶ Switch on the supply voltage.
- ▶ Download the project (see PNOZmulti Configurator's online help).
- ▶ Once the project has been successfully downloaded, the status of the inputs and outputs and the supply voltage will be shown on the display. The "RUN" LED will be lit.

7.5 Function test during commissioning



CAUTION!

It is essential to check that the safety devices operate correctly

- after the chip card has been exchanged
- after a project has been downloaded
- when the project has been deleted from the base unit's memory ("Reset Project" menu)

7.6 Using the chip card



NOTICE

The chip card contact is only guaranteed if the contact surface is clean and undamaged. For this reason please protect the chip card's contact surface from

- Contamination
- Contact
- Mechanical impact, such as scratches.



NOTICE

Switch off the product before inserting or exchanging the chip card.

Make sure that you do not bend the chip card as you insert it into the chip card slot.

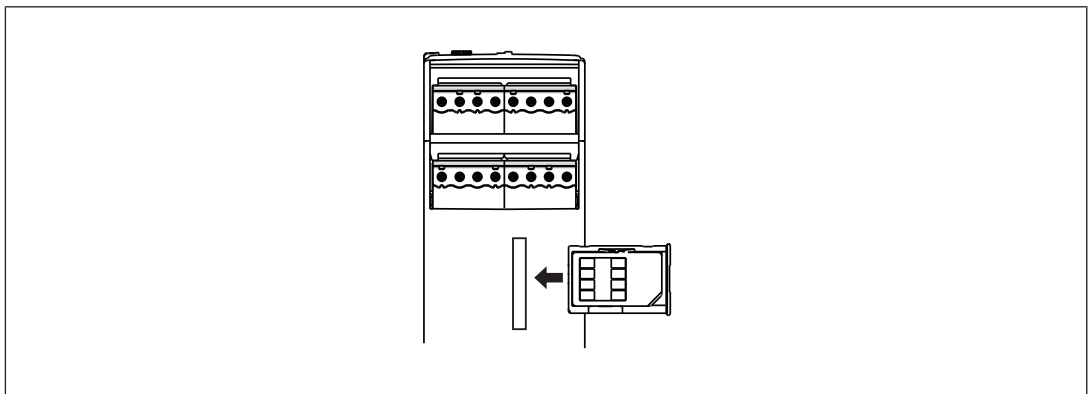

7.7 Connection example

Dual-channel E-STOP and safety gate wiring, monitored start (IM18), feedback loop (IM16)

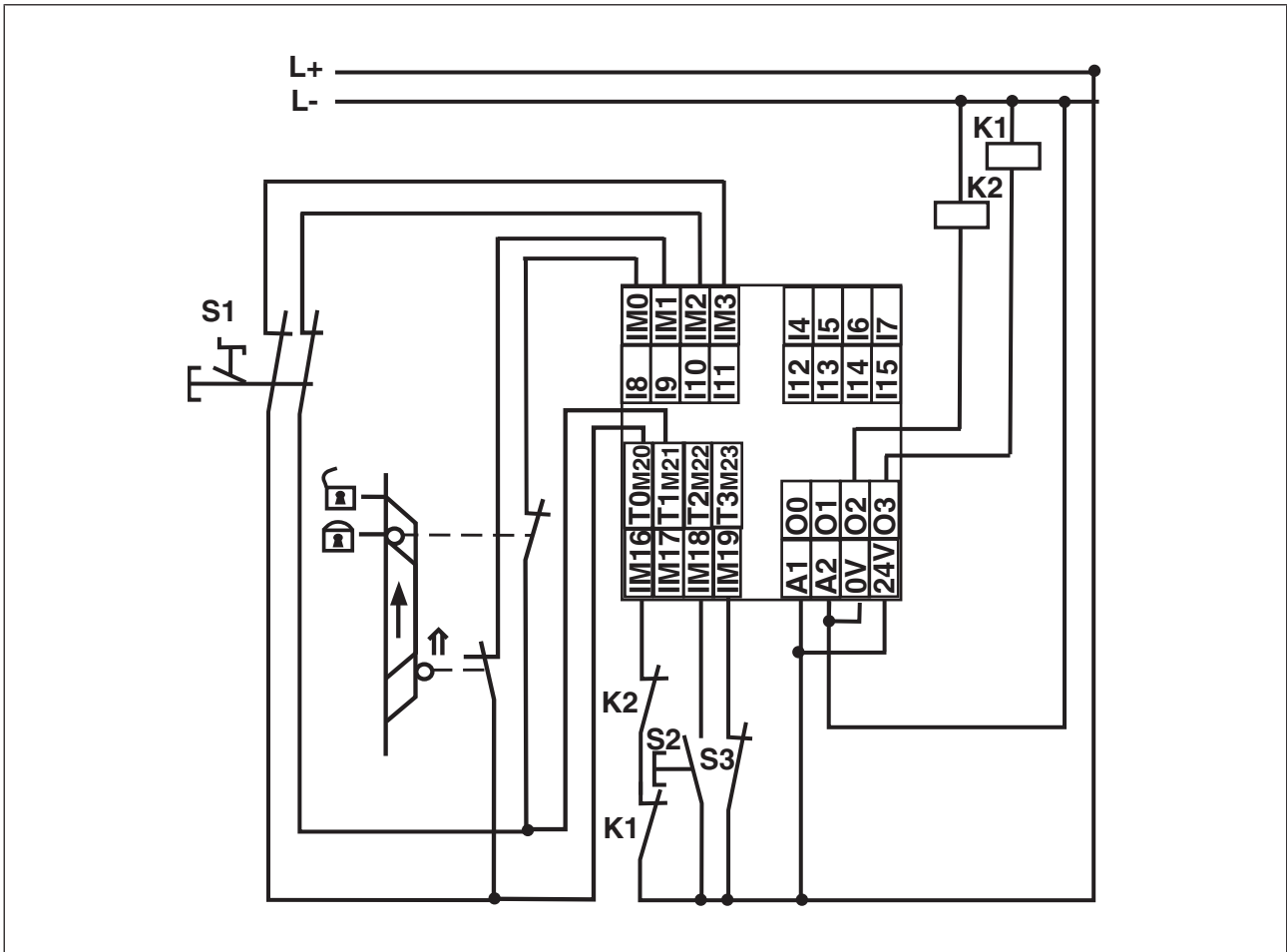



8 Operation















When the supply voltage is switched on, the PNOZmulti copies the configuration from the chip card.

8.1 LED indicators

The PNOZmulti control system is ready for operation when the "POWER" and "RUN" LEDs on the base unit are lit continuously.





Legend

-  LED on
-  LED flashes
-  LED off

Basis					Error
Run	Diag	Fault	IFAULT	OFAULT	
●					The existing user program has been deleted.
●					External error on the base unit, leading to a safe condition, e.g. chip card not inserted
●					External error on the base unit outputs, e.g. short across the contacts, leading to a safe condition.
●					Internal error on the base unit
●					Internal error on the base unit (inputs)
●					Internal error on the base unit (outputs)
					Base unit in a STOP condition
					External error on the base unit inputs, which does not lead to a safe condition, e.g. partially operated
					External error on the base unit outputs, which does not lead to a safe condition, e.g. feedback input defective
					The fieldbus module has not been recognised. or The base unit was identified by the PNOZmulti Configurator via the Ethernet interface or An existing fieldbus connection was interrupted.

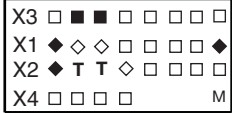
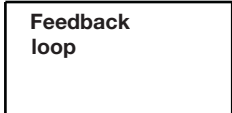
8.2 Display indicators

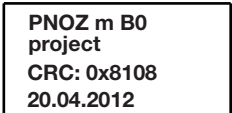
The LC display has four lines. It displays information and navigates the menu:

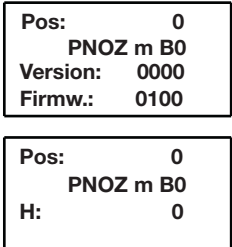
Display	Example	Description
RUN State of inputs/outputs and supply voltage	 <pre> X3 ■ ■ ■ □ □ □ □ □ X1 ◆ ◆ □ □ □ □ ◆ X2 ◆ T T ◆ □ □ □ □ X4 □ □ □ □ M </pre>	The lines are assigned terminals X1 ... X4 Status: ■ Input active □ Input inactive ◆ Semiconductor output active ◇ Semiconductor output inactive T Test pulse output Message display (bottom right): M Message present E Error message present
ERROR Status and error messages	 <pre> Feedback loop </pre>	Line 1 ... 4: Status and error messages as short text.
DISPLAY MESSAGE Display messages	 <pre> E-STOP pressed </pre>	Line 1 ... 4: Customised messages that are created in the PNOZmulti Configurator.
PROJECT INFO Project information	 <pre> PNOZ m B0 project CRC: 0x8108 20.04.2012 </pre>	1st line: Project name 2nd line: Project name 3rd line: Check sum (CRC) 4th line: Creation date
SHOW DEVICE INFO? Show device information	 <pre> Show device info? </pre>	Show device information for the base unit and expansion modules
DEVICE INFO Device information for the base unit and expansion modules	 <pre> Pos: 0 PNOZ m B0 Version: 0000 Firmw.: 0100 Pos: 0 PNOZ m B0 H: 0 </pre>	1st line: Module position (Pos) 2nd line: Product type 3rd line: Device version (Version) 4th line: Firmware version (Firmw.)

Display	Example	Description
<p>SHOW OPERATING INFO</p> <p>Displays specific operating parameters of the base unit and expansion units</p>	<div style="border: 1px solid black; padding: 5px; width: fit-content;"> <p>Pos: 0 Cycle: 10.000ms Supply: 24.0V Temp: 25.0°C</p> </div> <div style="border: 1px solid black; padding: 5px; width: fit-content;"> <p>Pos: 1 f1: 1.000Hz f2: 0.000Hz</p> </div>	<p>1st line: Module position (Pos)</p> <p>2nd to 4th line: Specific operating parameters</p> <p>e.g.:</p> <p>Cycle time</p> <p>Supply voltage</p> <p>Operating temperature</p> <p>Frequencies</p>
<p>SHOW ERROR STACK</p> <p>Show error stack</p>	<div style="border: 1px solid black; padding: 5px; width: fit-content;"> <p>Show error stack?</p> </div>	<p>Shows the error stack entries</p>
<p>ERROR STACK</p> <p>Error stack entries</p>	<div style="border: 1px solid black; padding: 5px; width: fit-content;"> <p>1/64 CH: A EC: 83 EN: 01 PA: 00 00 00 00 00</p> </div>	<p>1st line: Consecutive number</p> <p>2nd line: Error class (EC) and error information (EI)</p> <p>3rd line: Error number (EN) and error parameter (PA)</p> <p>4th line: Continuation of error parameter (PA)</p>
<p>IP ADDRESS</p> <p>IP address of base unit</p> <p>(only appears on base units to which a communication module with Ethernet interface is connected)</p>	<div style="border: 1px solid black; padding: 5px; width: fit-content;"> <p>IP Address 169.254.60.1/ 255.255.0.0</p> </div>	<p>2nd and 3rd line: IP address</p>
<p>INTERFACE</p> <p>Interface</p> <p>(only appears on base units to which a communication module is connected)</p>	<div style="border: 1px solid black; padding: 5px; width: fit-content;"> <p>Interface ■ USB</p> </div>	<p>Show selected interface / on expandable base units:</p> <p>Select interface</p>
<p>STOP Device?</p> <p>Stop device</p>	<div style="border: 1px solid black; padding: 5px; width: fit-content;"> <p>STOP Device?</p> </div>	<p>Bring device to a STOP condition</p>
<p>RESET PROJECT?</p> <p>Delete project</p>	<div style="border: 1px solid black; padding: 5px; width: fit-content;"> <p>RESET Project?</p> </div>	<p>Delete project from the base unit's memory</p>

Display	Example	Description
EXIT MENU? Exit menu		Exit menu

You can switch between the menu levels by pressing or rotating the knob.

8.2.1 Rotary knob

8.2.1.1 Function

The menu settings are made on the unit's display via a rotary knob. You have the option to make the settings on the knob by hand or with a screwdriver. If you make the settings with a screwdriver, the knob can remain within the unit.

8.2.1.2 Pull out and retract the knob

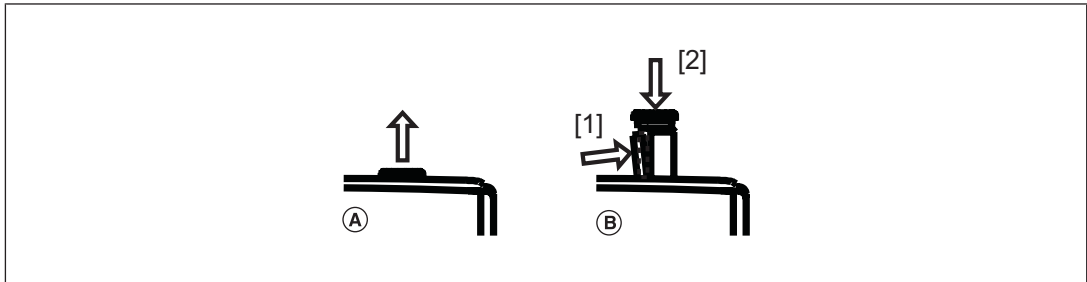

Knob :

- ▶ (A) pull out until it locks into position
- ▶ (B) release and push it back into the unit:
 - Press the bar on the side of the knob [1] towards the centre of the knob. This releases the knob.
 - Press the knob downwards [2] while keeping the bar pressed in

8.2.1.3 Rotate and press the knob

The settings are made via the rotary knob, as follows:



Press knob

- ▶ Confirm selection/setting
- ▶ Switch to menu



Rotate knob

- ▶ Select menu level

8.2.2 Switch between menu levels

Schematic representation of the menu functions

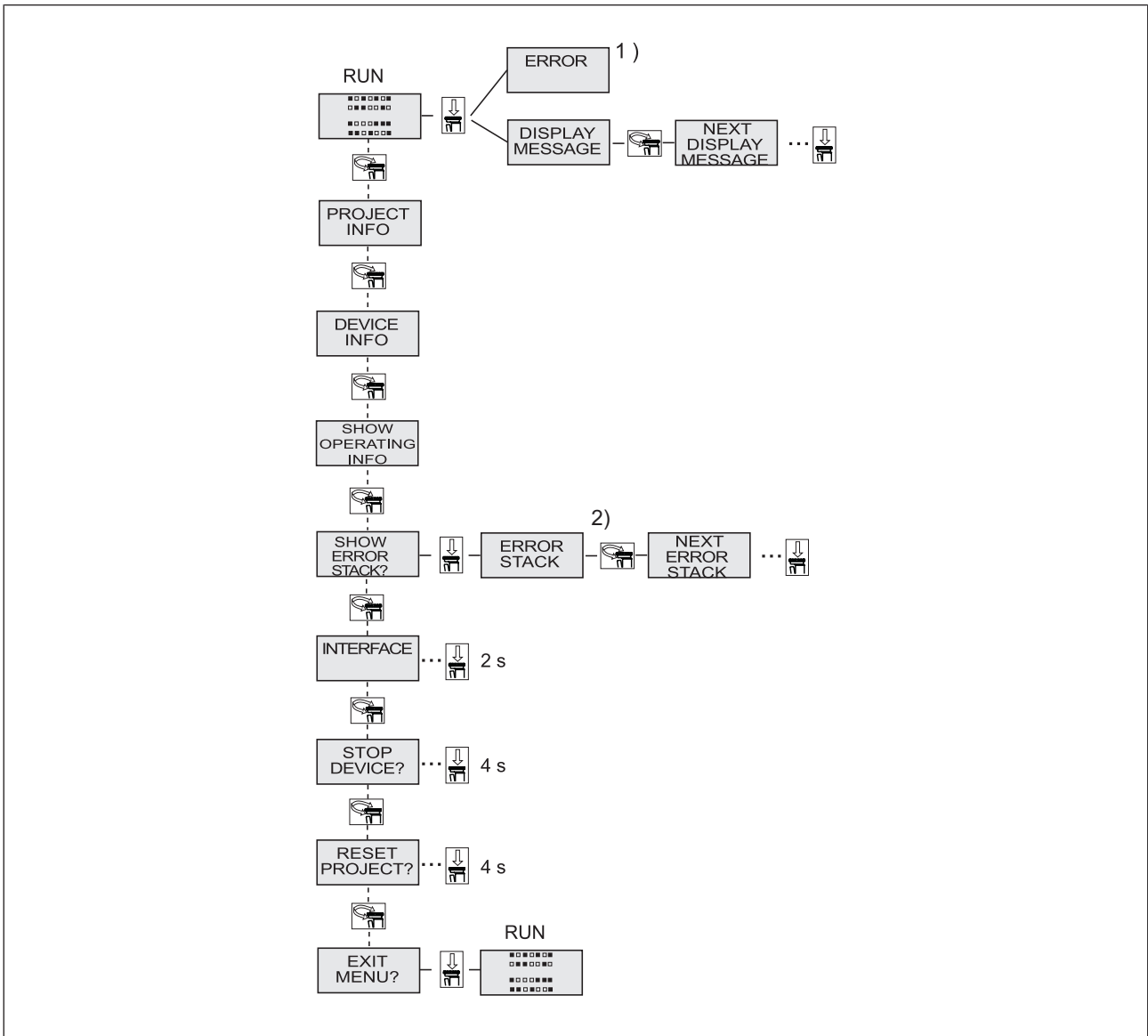

1) Further information on error messages can be found under "Unit diagnostics on the LC display"

2) Further information on the error stack can be found under "Error stack on the LC display"

8.2.3 Unit diagnostics on the LC display

Procedure for showing error messages on the LC display, when the errors do not lead to a safe condition:

- ▶ Use the rotary knob to display stored errors:

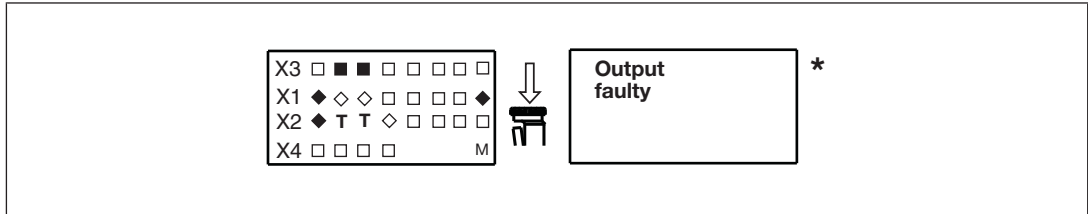

* If an error leads to a safe condition, the error message appears on the display immediately. Once the cause has been rectified, you will need to restart the unit

Procedure for restarting the unit:

- ▶ Press the rotary knob for between 3 and 8 seconds to reset the unit.

Error messages	Error
FAULTY PROJECT	Chip card contains a project which is faulty or incompatible.
CHIP CARD ?	Chip card is not inserted, blank or unreadable
FAULTY TEST PULSE	Error caused by test pulses
PARTIALLY OPERATED	Function element was or is partially operated
FEED BACK LOOP	External error at the feedback loop inputs
OPERATING MODE SWITCH SELECTOR	Error on the operating mode selector switch function element
FAULTY OUTPUT	External error on the output
OUTPUT WITH ADVANCED FAULT DETECTION	External error on the output with advanced fault detection
LOAD SUPPLY	Error in the supply voltage for the semiconductor outputs
FAULTY DEVICE	Internal error on the base unit
SUPPLY LOW	Supply voltage is below the tolerance level
SUPPLY HIGH	Supply voltage exceeds the tolerance level
CONFIGURATION	Hardware registry does not match the configuration
TEMPERATURE	Operating temperature is outside the permitted range
ERROR	Error that cannot be assigned

8.2.4 Error stack on the LC display

The error stack can be read from the PNOZmulti Configurator or shown on the LC display. The error stack helps Pilz technical support with fault diagnostics. The error stack can store up to 64 status and error messages.

The following information is shown on the LC display:

- ▶ Sequential number of an error stack entry. A new error stack entry is stored in first place.
- ▶ Error class (EC) and error information (EI)
- ▶ Error number (EN) and five error parameters (PA)

Procedure for displaying the error stack on the LC display:

- ▶ Use the rotary knob to display the error stack.

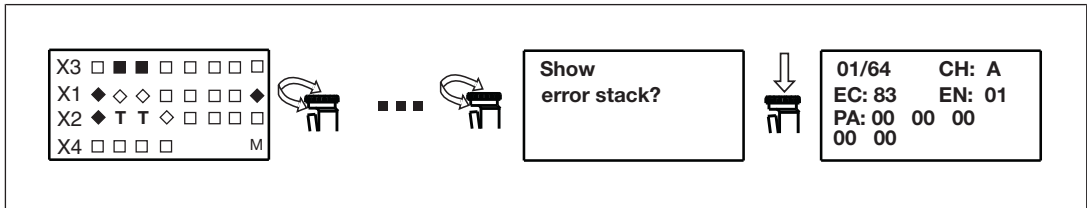

INFORMATION

Use the rotary knob to exit the error stack.

Procedure for reading the error stack with the PNOZmulti Configurator:

- ▶ See online help for the PNOZmulti Configurator

9 Maintenance and testing

It is not necessary to perform maintenance work on the product in normal operation. Please return any faulty products to Pilz.

10 Technical details

General	
Certifications	CE, EAC, KOSHA, TÜV, UKCA, cULus Listed
Application range	Failsafe
Module's device code	0060h
Electrical data	
Supply voltage	
for	Supply to the system
Voltage	24 V
Kind	DC
Voltage tolerance	-20 %/+25 %
Max. continuous current that the external power supply must provide	1,6 A
Inrush current that the external power supply must provide	3 A
External unit fuse protection F1	6 A, circuit breaker 24 V DC, characteristic B
Supply voltage	
for	Supply to the SC outputs
Voltage	24 V
Kind	DC
Voltage tolerance	-20 %/+25 %
Max. continuous current that the external power supply must provide	8 A
External unit fuse protection F2	10 A, circuit breaker 24 V DC, characteristic B/C
Potential isolation	Yes
Supply voltage	
Current consumption	32 mA
Power consumption	0,8 W
Max. power dissipation of module	7,4 W
Status indicator	Display, LED
Permitted loads	inductive, capacitive, resistive
Configurable inputs/outputs (inputs or auxiliary outputs)	
Quantity	8
Potential isolation	No
Configurable inputs	
Input voltage in accordance with EN 61131-2 Type 1	24 V
Input current at rated voltage	5 mA
Input current range	2,5 - 5,3 mA
Pulse suppression	0,5 ms
Maximum input delay	2 ms

Configurable inputs/outputs (inputs or auxiliary outputs)

Configurable auxiliary outputs

Voltage	24 V
Output current	75 mA
Output current range	0 - 100 mA
Max. transient pulsed current	500 mA
Short circuit-proof	Yes
Residual current at "0"	0,5 mA
Voltage at "1"	UB - 2 V at 0.1 A

Inputs

Quantity	12
Input voltage in accordance with EN 61131-2 Type 1	24 V DC
Input current at rated voltage	5 mA
Input current range	2,5 - 5,3 mA
Pulse suppression	0,5 ms
Maximum input delay	2 ms
Potential isolation	No

Semiconductor outputs

Number of positive-switching single-pole semiconductor outputs	4
Switching capability	
Voltage	24 V
Current	2 A
Permitted current range	0,000 - 2,500 A
Residual current at "0" signal	0,05 mA
Max. transient pulsed current	12 A
Max. capacitive load	1 µF
Max. internal voltage drop	500 mV
Max. duration of off time during self test	330 µs
Switch-off delay	1 ms
Potential isolation	Yes
Short circuit-proof	Yes

Test pulse outputs

Number of test pulse outputs	4
Voltage	24 V
Current	0,1 A
Max. duration of off time during self test	5 ms
Short circuit-proof	Yes
Potential isolation	No

Times

Simultaneity in the two-hand circuit	0,5 s
Processing time	30 ms

Environmental data

Ambient temperature	
in accordance with the standard	EN 60068-2-14
Temperature range	0 - 60 °C
Forced convection in control cabinet off	55 °C
Storage temperature	
in accordance with the standard	EN 60068-2-1/-2
Temperature range	-25 - 70 °C
Climatic suitability	
in accordance with the standard	EN 60068-2-30, EN 60068-2-78
Condensation during operation	Not permitted
Max. operating height above SL	2000 m
EMC	EN 61131-2
Vibration	
in accordance with the standard	EN 60068-2-6
Frequency	5 - 150 Hz
Acceleration	1g
Shock stress	
in accordance with the standard	EN 60068-2-27
Acceleration	15g
Duration	11 ms
Airgap creepage	
in accordance with the standard	EN 61131-2
Overvoltage category	II
Pollution degree	2
Protection type	
in accordance with the standard	EN 60529
Housing	IP20
Terminals	IP20
Mounting area (e.g. control cabinet)	IP54

Potential isolation

Potential isolation between	SC output and system voltage
Type of potential isolation	Basic insulation
Rated insulation voltage	30 V
Rated surge voltage	2500 V

Mechanical data

Mounting position	horizontally on mounting rail
DIN rail	
Top hat rail	35 x 15 EN/IEC 60715, 35 x 7,5 EN/IEC 60715
Recess width	27 mm
Cable length	
Max. cable length per input	1 km
Sum of individual cable lengths at the test pulse output	2 km

Mechanical data

Material	
Bottom	PC
Front	PC
Top	PC
Connection type	Spring-loaded terminal, screw terminal
Mounting type	plug-in
Conductor cross section with screw terminals	
1 core flexible	0,25 - 2,5 mm ² , 24 - 12 AWG
2 core with the same cross section, flexible without crimp connectors or with TWIN crimp connectors	0,2 - 1,5 mm ² , 24 - 16 AWG
Torque setting with screw terminals	0,5 Nm
Conductor cross section with spring-loaded terminals:	
Flexible with/without crimp connector	0,2 - 2,5 mm ² , 24 - 12 AWG
Spring-loaded terminals: Terminal points per connection	2
Stripping length with spring-loaded terminals	9 mm
Dimensions	
Height	101,4 mm
Width	45 mm
Depth	120 mm
Weight	235 g

Where standards are undated, the 2018-07 latest editions shall apply.

10.1 Safety characteristic data



NOTICE

You must comply with the safety characteristic data in order to achieve the required safety level for your plant/machine.

Unit	Operating mode	EN ISO 13849-1: 2015 PL	EN ISO 13849-1: 2015 Category	EN IEC 62061 SIL CL/ maximum SIL	EN IEC 62061 PFH _D [1/h]	EN/IEC 61511 SIL	EN/IEC 61511 PFD	EN ISO 13849-1: 2015 T _M [year]
------	----------------	----------------------------	----------------------------------	---	--	---------------------	---------------------	---

Logic

CPU	2-channel	PL e	Cat. 4	SIL 3	4,74E-10	SIL 3	4,00E-05	20
Expansion left	–	PL e	Cat. 4	SIL 3	3,30E-11	SIL 3	2,49E-06	20
Expansion right	–	PL e	Cat. 4	SIL 3	2,79E-11	SIL 3	2,18E-06	20

Input

Inputs	1-channel	PL d	Cat. 2	SIL 2	3,85E-09	SIL 2	3,38E-04	20
Inputs	2-channel	PL e	Cat. 4	SIL 3	7,95E-11	SIL 3	6,90E-06	20
Inputs	Short circuit-forming safety mats	PL d	Cat. 3	SIL 2	1,06E-09	SIL 2	9,14E-05	20
Inputs	1-ch., pulsed light barrier	PL e	Cat. 4	SIL 3	3,85E-10	SIL 3	3,40E-05	20

Output

SC outputs	1-channel with advanced fault detection	PL e	Cat. 4	SIL 3	1,66E-11	SIL 3	1,46E-06	20
SC outputs	1-channel	PL d	Cat. 2	SIL 2	1,57E-10	SIL 2	1,35E-05	20
SC outputs	2-channel	PL e	Cat. 4	SIL 3	1,29E-10	SIL 3	1,12E-05	20

Explanatory notes for the safety-related characteristic data:

- ▶ Safety characteristic data in accordance with EN IEC 62061 and EN/IEC 61511 was calculated based on EN/IEC 61508.
- ▶ T_M is the maximum mission time in accordance with EN ISO 13849-1. The value also applies as the retest interval in accordance with EN/IEC 61508-6 and EN/IEC 61511 and as the proof test interval and mission time in accordance with EN IEC 62061.

All the units used within a safety function must be considered when calculating the safety characteristic data.



INFORMATION

A safety function's SIL/PL values are **not** identical to the SIL/PL values of the units that are used and may be different. We recommend that you use the PASCAL software tool to calculate the safety function's SIL/PL values.

10.2 Classification according to ZVEI, CB24I

The following tables describe the classes and specific values of the product interface and the classes of interfaces compatible with it. The classification is described in the ZVEI position paper "Classification of Binary 24 V Interfaces - Functional Safety aspects covered by dynamic testing".

Input Interfaces

Drain	
Interface	Module
Class	C2
Source	
Interface	Sensor
Class	C2, C3

Drain parameters

Max. test pulse duration	500 µs
Min. input resistance	5,6 kOhm
Max. capacitive load	126 nF

Single-pole output Interfaces

Source	
Interface	Module
Class	C2
Drain	
Interface	Actuator
Class	C1, C2

Parameter source

Max. test pulse duration	330 µs
Max. rated current	2 A
Max. capacitive load	1 µF

11 Supplementary data

11.1 Maximum capacitive load C (μF) with load current I (A) at the semiconductor outputs

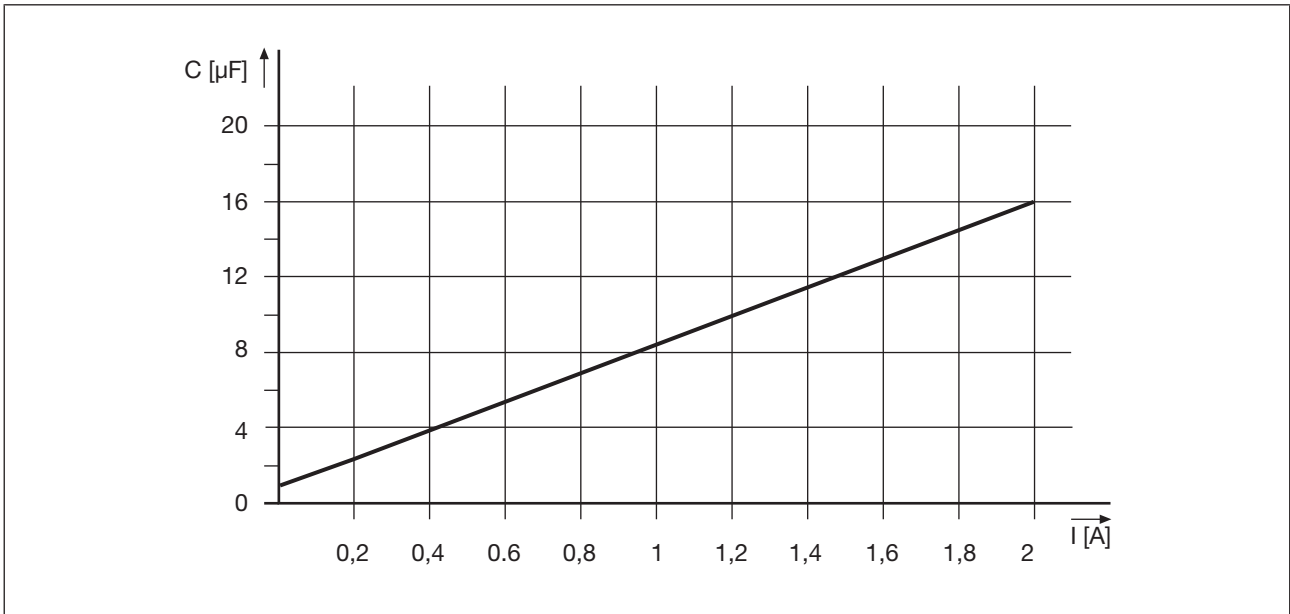

11.2 Maximum permitted total current of the semiconductor outputs

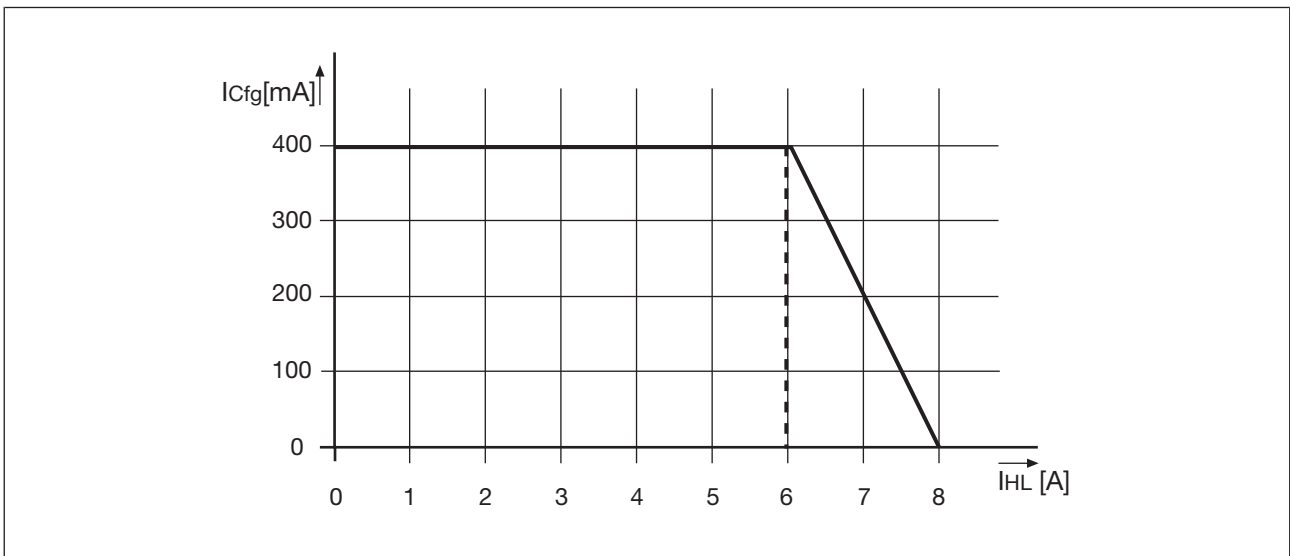

I_{Cfg} : Total current of the configurable semiconductor outputs (auxiliary outputs)

I_{HL} : Total current: Semiconductor outputs (safety outputs)

11.3 Maximum permitted humidity

11.3.1 Max. relative humidity, operation

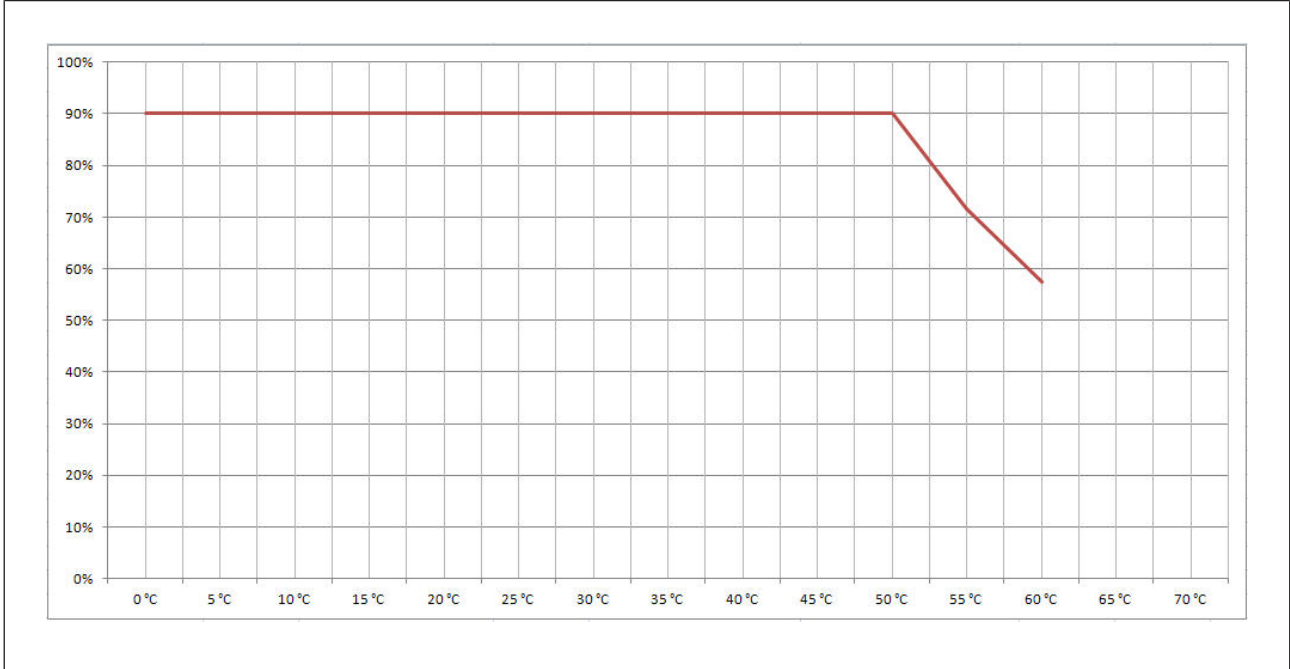

11.3.2 Max. relative humidity, storage

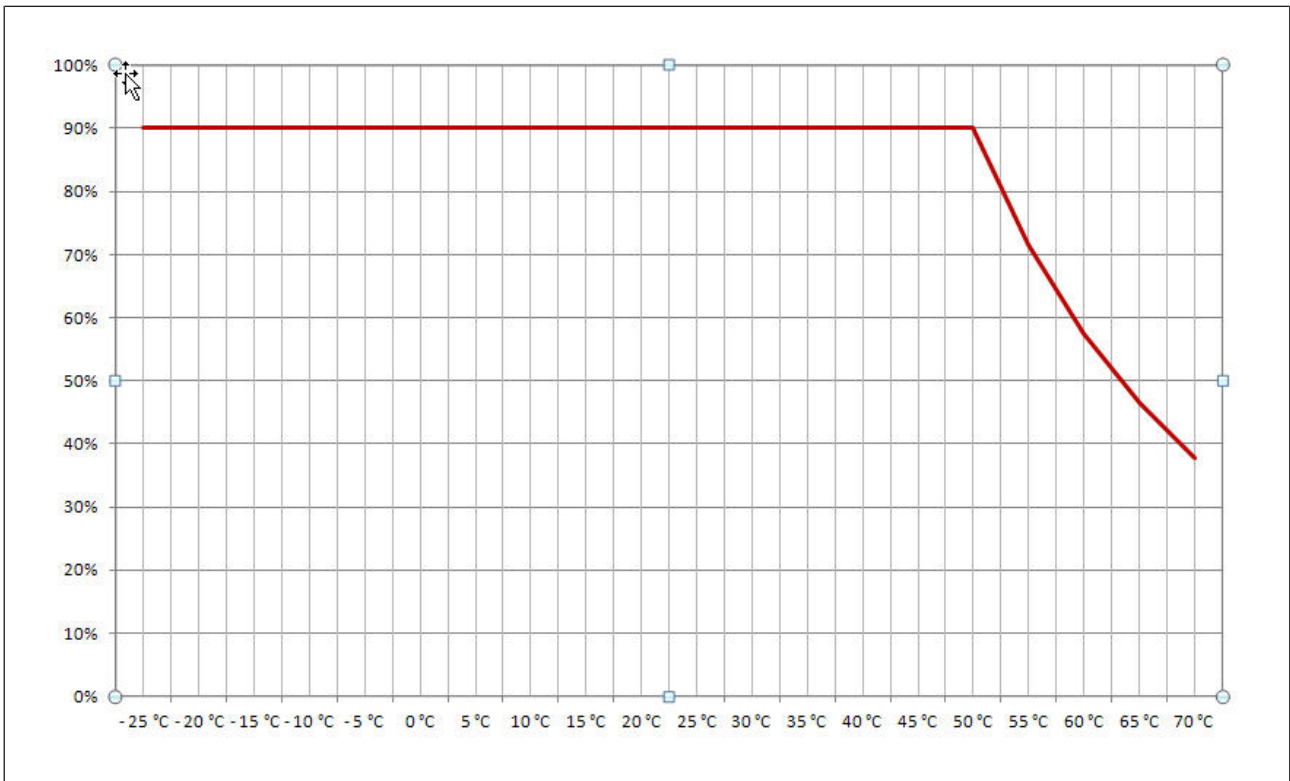

12 Order reference

12.1 Product

Product type	Features	Order no.
PNOZ m B0	Configurable safe small controllers PNOZmulti 2, base unit, expandable, 20 safe digital inputs, 4 safe semiconductor outputs.	772100

12.2 Accessories

12.2.1 Chip card

Product type	Features	Order no.
PNOZmulti Chipcard 1 piece 32kB	PNOZmulti chip card, 1 piece, 32 kB.	779211
PNOZmulti Chipcard 1 piece 8kB	PNOZmulti chip card, 1 piece, 8 kB.	779201

12.2.2 Replacement terminals

Product type	Features	Order no.
PNOZ s Set1screw terminals 45mm	Set of plug-in replacement terminals 8-pin of screw type, PU = 1 piece each X1, X2, X3, X4.	750008
PNOZ s Set1 spring- loaded terminals 45mm	Set of plug-in replacement terminals 8-pin of spring-loaded type, PU = 1 piece each X1, X2, X3, X4.	751008

12.2.3 Cable

Product type	Features	Order no.
PSSu A USB-CAB03	PSSu, USB cable, length 3 m.	312992
PSSu A USB-CAB05	PSSu, USB cable, length 5 m.	312993

12.2.4 Terminating plug

Product type	Features	Order no.
PNOZ mm0.xp ter- minator left (10 pcs.)	Terminator on the left-hand side of the base unit PNOZmulti, yellow/black (10 pieces).	779261

13 EC declaration of conformity

This product/these products meet the requirements of the directive 2006/42/EC for machinery of the European Parliament and of the Council. The complete EC Declaration of Conformity is available on the Internet at www.pilz.com/downloads.

Authorised representative: Norbert Fröhlich, Pilz GmbH & Co. KG, Felix-Wankel-Str. 2, 73760 Ostfildern, Germany

14 UKCA-Declaration of Conformity

This product(s) complies with following UK legislation: Supply of Machinery (Safety) Regulation 2008.

The complete UKCA Declaration of Conformity is available on the Internet at www.pilz.com/downloads.

Representative: Pilz Automation Technology, Pilz House, Little Colliers Field, Corby, Northamptonshire, NN18 8TJ United Kingdom, eMail: mail@pilz.co.uk

► Support

Technical support is available from Pilz round the clock.

Americas

Brazil

+55 11 97569-2804

Canada

+1 888 315 7459

Mexico

+52 55 5572 1300

USA (toll-free)

+1 877-PILZUSA (745-9872)

Asia

China

+86 21 60880878-216

Japan

+81 45 471-2281

South Korea

+82 31 778 3300

Australia and Oceania

Australia

+61 3 95600621

New Zealand

+64 9 6345350

Europe

Austria

+43 1 7986263-0

Belgium, Luxembourg

+32 9 3217570

France

+33 3 88104003

Germany

+49 711 3409-444

Ireland

+353 21 4804983

Italy, Malta

+39 0362 1826711

Scandinavia

+45 74436332

Spain

+34 938497433

Switzerland

+41 62 88979-32

The Netherlands

+31 347 320477

Turkey

+90 216 5775552

United Kingdom

+44 1536 462203

You can reach our international hotline on:

+49 711 3409-222

support@pilz.com

Pilz develops environmentally-friendly products using ecological materials and energy-saving technologies. Offices and production facilities are ecologically designed, environmentally-aware and energy-saving. So Pilz offers sustainability, plus the security of using energy-efficient products and environmentally-friendly solutions.



We are represented internationally. Please refer to our homepage www.pilz.com for further details or contact our headquarters.

Headquarters: Pilz GmbH & Co. KG, Felix-Wankel-Straße 2, 73760 Ostfildern, Germany
Telephone: +49 711 3409-0, Telefax: +49 711 3409-133, E-Mail: info@pilz.com, Internet: www.pilz.com

PILZ
THE SPIRIT OF SAFETY

1002660-EN-11, 2023-06 Printed in Germany
© Pilz GmbH & Co. KG, 2019

CECE®, CHRE®, CMSE®, InduraNET p®, Leansafe®, Master of Safety®, Master of Security®, PAS4000®, PAScall®, PASconfig®, Pilz®, PTT®, PLID®, PMCPirimo®, PMCPiritego®, PMCTendo®, PMD®, PMJ®, PNOZ®, PRCM®, PRM®, PRM®, PRTM®, PSEN®, PSS®, PVS®, SafetyBUS p®, SafetyEYE®, SafetyNET p®, THE SPIRIT OF SAFETY® are registered and protected trademarks of Pilz GmbH & Co. KG in some countries. We would point out that product features may vary from the details stated in this document, depending on the status at the time of publication and the scope of the equipment. We accept no responsibility for the validity, accuracy and entirety of the text and graphics presented in this information. Please contact our Technical Support if you have any questions.