



## PNOZ ml1p

**PILZ**  
THE SPIRIT OF SAFETY

- ▶ Configurable, safe small controllers PNOZmulti Classic

This document is the original document.

All rights to this documentation are reserved by Pilz GmbH & Co. KG. Copies may be made for the user's internal purposes. Suggestions and comments for improving this documentation will be gratefully received.

Source code from third-party manufacturers or open source software has been used for some components. The relevant licence information is available on the Internet on the Pilz homepage.

Pilz®, PIT®, PMI®, PNOZ®, Primo®, PSEN®, PSS®, PVIS®, SafetyBUS p®, SafetyEYE®, SafetyNET p®, the spirit of safety® are registered and protected trademarks of Pilz GmbH & Co. KG in some countries.



SD means Secure Digital

<b>1</b>	<b>Introduction</b> .....	<b>5</b>
1.1	Validity of documentation .....	5
1.2	Using the documentation .....	5
1.3	Definition of symbols .....	5
<b>2</b>	<b>Overview</b> .....	<b>7</b>
2.1	Scope .....	7
2.2	Unit features .....	7
2.3	Front view .....	8
<b>3</b>	<b>Safety</b> .....	<b>9</b>
3.1	Intended use .....	9
3.2	System requirements .....	9
3.3	Safety regulations .....	10
3.3.1	Safety assessment .....	10
3.3.2	Use of qualified personnel .....	10
3.3.3	Warranty and liability .....	10
3.3.4	Disposal .....	10
3.3.5	For your safety .....	11
<b>4</b>	<b>Function Description</b> .....	<b>12</b>
4.1	Integrated protection mechanisms .....	12
4.2	Functions .....	12
4.3	System reaction time .....	14
4.4	Block diagram .....	14
<b>5</b>	<b>Installation</b> .....	<b>15</b>
5.1	General installation guidelines .....	15
5.2	Dimensions in mm .....	15
5.3	Connecting the base unit and expansion modules .....	16
<b>6</b>	<b>Commissioning</b> .....	<b>17</b>
6.1	General wiring guidelines .....	17
6.2	Download modified project to the PNOZmulti system .....	18
6.3	Connection .....	18
6.4	Connection examples .....	19
6.4.1	Example: Series connection of 3 base units .....	19
6.4.2	Example: Connection of 5 base units .....	20
<b>7</b>	<b>Operation</b> .....	<b>21</b>
7.1	LED indicators .....	21
7.2	Fault detection .....	21
<b>8</b>	<b>Technical details</b> .....	<b>22</b>
8.1	Safety characteristic data .....	25
<b>9</b>	<b>Order reference</b> .....	<b>26</b>
9.1	Product .....	26

9.2 Accessories ..... 26

# 1 Introduction

## 1.1 Validity of documentation

This documentation is valid for the product PNOZ ml1p. It is valid until new documentation is published.

This operating manual explains the function and operation, describes the installation and provides guidelines on how to connect the product.

## 1.2 Using the documentation

This document is intended for instruction. Only install and commission the product if you have read and understood this document. The document should be retained for future reference.

## 1.3 Definition of symbols

Information that is particularly important is identified as follows:



### **DANGER!**

This warning must be heeded! It warns of a hazardous situation that poses an immediate threat of serious injury and death and indicates preventive measures that can be taken.



### **WARNING!**

This warning must be heeded! It warns of a hazardous situation that could lead to serious injury and death and indicates preventive measures that can be taken.



### **CAUTION!**

This refers to a hazard that can lead to a less serious or minor injury plus material damage, and also provides information on preventive measures that can be taken.



### **NOTICE**

This describes a situation in which the product or devices could be damaged and also provides information on preventive measures that can be taken. It also highlights areas within the text that are of particular importance.



**INFORMATION**

This gives advice on applications and provides information on special features.

## 2 Overview

### 2.1 Scope

- ▶ Expansion module PNOZ ml1p
- ▶ Jumper

### 2.2 Unit features

Application of the product PNOZ ml1p:

Link module to safely connect two configurable small control systems PNOZmulti.

The product has the following features:

- ▶ Can be configured in the PNOZmulti Configurator
- ▶ Point-to-point connection via 4-core shielded and twisted-pair cable
- ▶ 32 virtual inputs and 32 virtual outputs
- ▶ Status indicators
  - Operating state
  - Error
  - Connection status
- ▶ Coated version:
  - Increased environmental requirements (see [Technical details](#) [ 22])

## 2.3 Front view

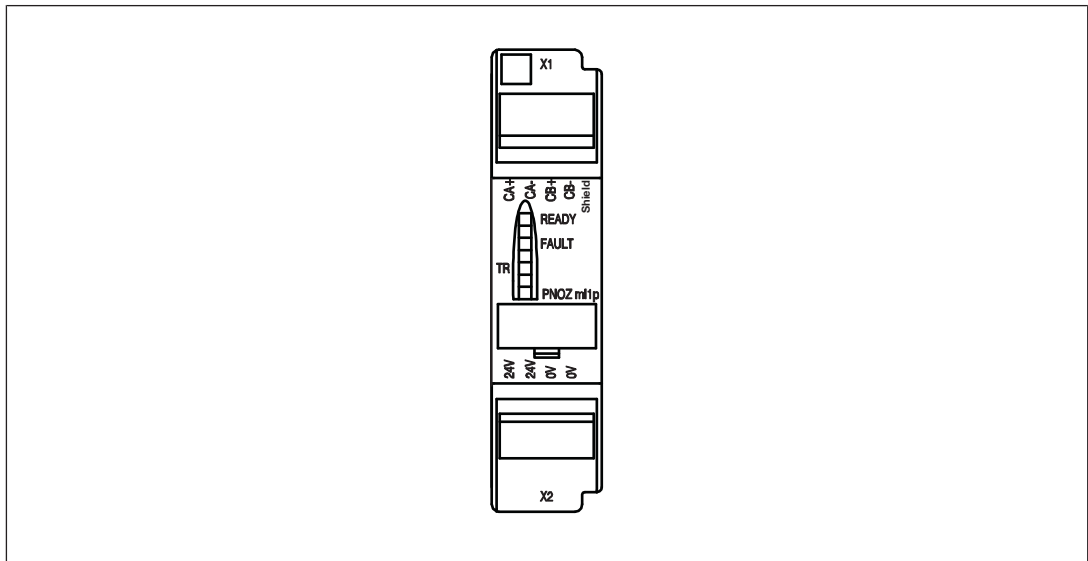

Key:

- ▶ 0 V, 24 V:  
Supply connections
- ▶ CA+, CA-, CB+, CB-:  
Connections for 2 expansion modules PNOZ ml1p
- ▶ Shield:  
Connection for the cable shield



## 3 Safety

### 3.1 Intended use

The expansion module is used for the point-to-point connection of safe virtual inputs and outputs between two base units.

The expansion module may only be connected to a base unit from the PNOZmulti system (please refer to the document "PNOZmulti System Expansion" for details of the base units that can be connected).

The configurable small control systems PNOZmulti are used for the safety-related interruption of safety circuits and are designed for use in:

- ▶ E-STOP equipment
- ▶ Safety circuits in accordance with VDE 0113 Part 1 and EN 60204-1

The coated version of the product PNOZ ml1p is suitable for use where there are increased environmental requirements (see [Technical details \[📖 22\]](#)).

The following is deemed improper use in particular

- ▶ Any component, technical or electrical modification to the product,
- ▶ Use of the product outside the areas described in this manual,
- ▶ Use of the product outside the technical details (see [Technical details \[📖 22\]](#)).



#### NOTICE

#### EMC-compliant electrical installation

The product is designed for use in an industrial environment. The product may cause interference if installed in other environments. If installed in other environments, measures should be taken to comply with the applicable standards and directives for the respective installation site with regard to interference.

### 3.2 System requirements

Please refer to the "Product Modifications PNOZmulti" document in the "Version overview" section for details of which versions of the base unit and PNOZmulti Configurator can be used for this product.

## 3.3 Safety regulations

### 3.3.1 Safety assessment

Before using a device it is necessary to perform a safety assessment in accordance with the Machinery Directive.

Functional safety is guaranteed for the product as a single component. However, this does not guarantee the functional safety of the overall plant/machine. In order to achieve the required safety level for the overall plant/machine, define the safety requirements for the plant/machine and then define how these must be implemented from a technical and organisational standpoint.

### 3.3.2 Use of qualified personnel

The products may only be assembled, installed, programmed, commissioned, operated, maintained and decommissioned by competent persons.

A competent person is someone who, because of their training, experience and current professional activity, has the specialist knowledge required to test, assess and operate the work equipment, devices, systems, plant and machinery in accordance with the general standards and guidelines for safety technology.

It is the company's responsibility only to employ personnel who

- ▶ Are familiar with the basic regulations concerning health and safety / accident prevention,
- ▶ Have read and understood the information provided in this description under "Safety",
- ▶ And have a good knowledge of the generic and specialist standards applicable to the specific application.

### 3.3.3 Warranty and liability

All claims to warranty and liability will be rendered invalid if

- ▶ The product was used contrary to the purpose for which it is intended,
- ▶ Damage can be attributed to not having followed the guidelines in the manual,
- ▶ Operating personnel are not suitably qualified,
- ▶ Any type of modification has been made (e.g. exchanging components on the PCB boards, soldering work etc.).

### 3.3.4 Disposal

- ▶ In safety-related applications, please comply with the mission time  $T_M$  in the safety-related characteristic data.
- ▶ When decommissioning, please comply with local regulations regarding the disposal of electronic devices (e.g. Electrical and Electronic Equipment Act).

### 3.3.5 For your safety

The unit meets all the necessary conditions for safe operation. However, you should always ensure that the following safety requirements are met:

- ▶ This operating manual only describes the basic functions of the unit. The expanded functions are described in the PNOZmulti Configurator's online help. Only use these functions once you have read and understood the documentations.
- ▶ Do not open the housing or make any unauthorised modifications.
- ▶ Please make sure you shut down the supply voltage when performing maintenance work (e.g. exchanging contactors).

## 4 Function Description

### 4.1 Integrated protection mechanisms

The relay meets the following safety requirements:

- ▶ The circuit is redundant with built-in self-monitoring.
- ▶ The safety device remains effective in the case of a component failure.

### 4.2 Functions

The PNOZ ml1p link module is used to safely transfer the input information from 32 virtual inputs and 32 virtual outputs between two PNOZmulti systems. One link module is assigned to each base unit. Data is exchanged cyclically.

The function of the inputs and outputs on the control system depends on the safety circuit created using the PNOZmulti Configurator. A chip card is used to download the safety circuit to the base unit. The base unit has 2 microcontrollers that monitor each other. They evaluate the input circuits on the base unit and expansion modules and switch the outputs on the base unit and expansion modules accordingly.

The LEDs on the base unit and expansion modules indicate the status of the configurable control system PNOZmulti.

The online help on the PNOZmulti Configurator contains descriptions of the operating modes and all the functions of the control system, plus connection examples.

#### Data exchange:

- ▶ Data is exchanged cyclically.
- ▶ After the end of a PNOZmulti cycle, each base unit sends its output data to its link module. This output data is immediately sent to the link module on the other base unit.
- ▶ At the same time, the base unit reads the input data from the link module.

#### Connection of multiple base units:

Any number of base units can be connected via PNOZ ml1p link modules. Two PNOZ ml1p are required for the connection between two base units. However, only a maximum of 4 link modules may be connected to any one base unit.

#### Data transmission time:

The data transmission time  $t_{BUS}$  is the time between the virtual output at base unit 1 being set and the virtual input at base unit 2 becoming available (see [Technical details](#) [ 22]).

#### The maximum reaction time for series connection of n base units

This is the time between the activation of a safety function at the input on one base unit and the switching of an output on the connected base unit.

- ▶ The maximum reaction time  $t_{SUM}$  includes the following times:

$t_{ON}$ : Input delay = 4 ms

$t_{COND}$ : Switch-off delay of semiconductor output = 30 ms

$t_{REL}$ : Switch-off delay of relay output = 50 ms

$t_{BUS}$ : Data transmission time between two base units = 35 ms

n: Number of connections between base units

The maximum reaction time  $t_{SUM}$  for series connection of n base units

- ▶ On semiconductor outputs:

$$t_{SUM} = t_{ON} + (n * t_{BUS}) + t_{COND}$$

- ▶ On relay outputs:

$$t_{SUM} = t_{ON} + (n * t_{BUS}) + t_{REL}$$



**CAUTION!**

For signals that are forwarded or received via the link module, a calculation must always be made in accordance with the above formulas.

- ▶ Input delay and switch-off delay are only included once in the reaction time. The data transmission time between the link modules is multiplied by the number of connections.
- ▶ Please refer to the [Connection examples](#)  19].



**CAUTION!**

For signals that are forwarded or received via the link module, the overall reaction time, e.g. the maximum reaction time of the series connection of n base units, must always be considered in the risk assessment. The risk assessment must consider all hazards as regards the reaction time and the safety distance. The overall reaction time must not delay the arrival of a safe condition by more than the permitted time.

**Virtual inputs and outputs:**

Inputs and outputs for both PNOZmulti systems are assigned in the PNOZmulti Configurator. Inputs and outputs with the same number are assigned to each other, e.g. output o5 on one PNOZmulti system to input i5 on the other PNOZmulti system.

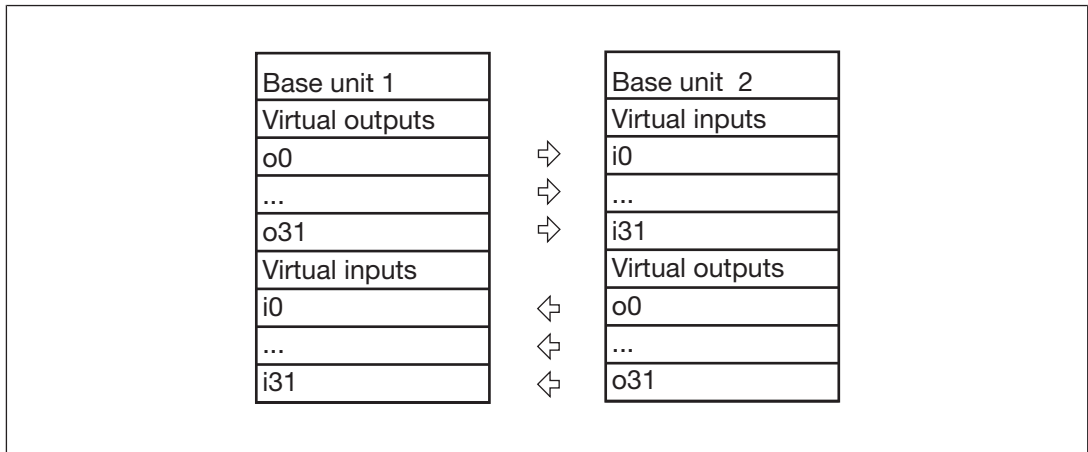

### 4.3 System reaction time

Calculation of the maximum reaction time between an input switching off and a linked output in the system switching off is described in the document "PNOZmulti System Expansion".

### 4.4 Block diagram

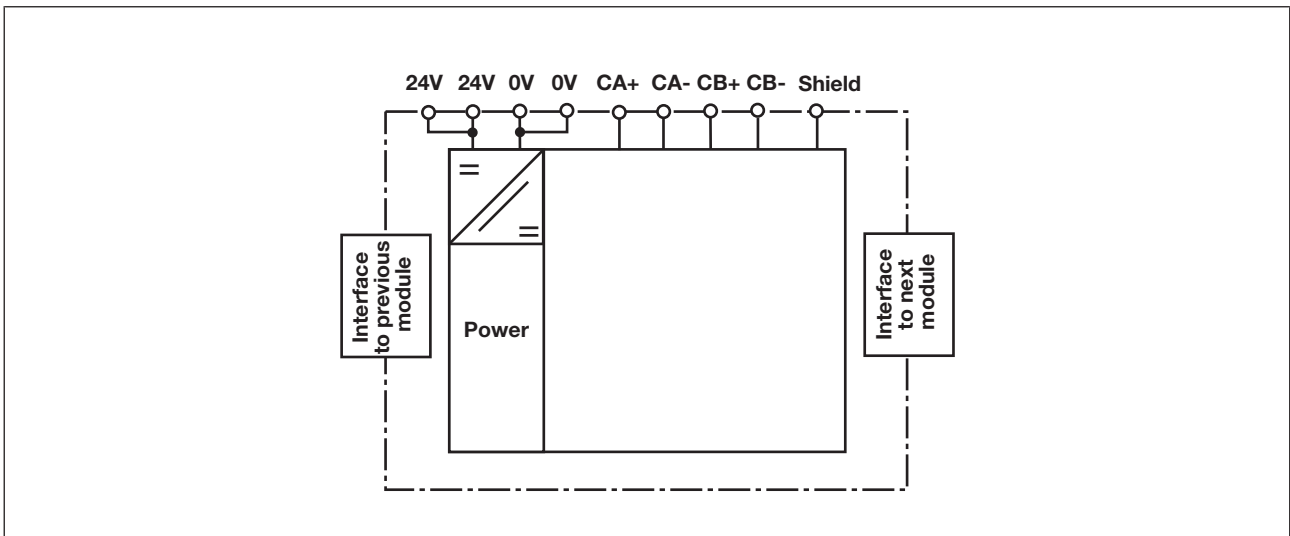

## 5 Installation

### 5.1 General installation guidelines

- ▶ The control system should be installed in a control cabinet with a protection type of at least IP54. Fit the control system to a horizontal mounting rail. The venting slots must face upward and downward. Other mounting positions could destroy the control system.
- ▶ Use the locking elements on the rear of the unit to attach it to a mounting rail. Connect the control system to the mounting rail in an upright position, so that the earthing springs on the control system are pressed on to the mounting rail.
- ▶ The ambient temperature of the devices in the control cabinet must not exceed the figure stated in the technical details. Air conditioning may otherwise be required.
- ▶ To comply with EMC requirements, the mounting rail must have a low impedance connection to the control cabinet housing.



#### NOTICE

Damage due to electrostatic discharge!

Electrostatic discharge can damage components. Ensure against discharge before touching the product, e.g. by touching an earthed, conductive surface or by wearing an earthed armband.

### 5.2 Dimensions in mm

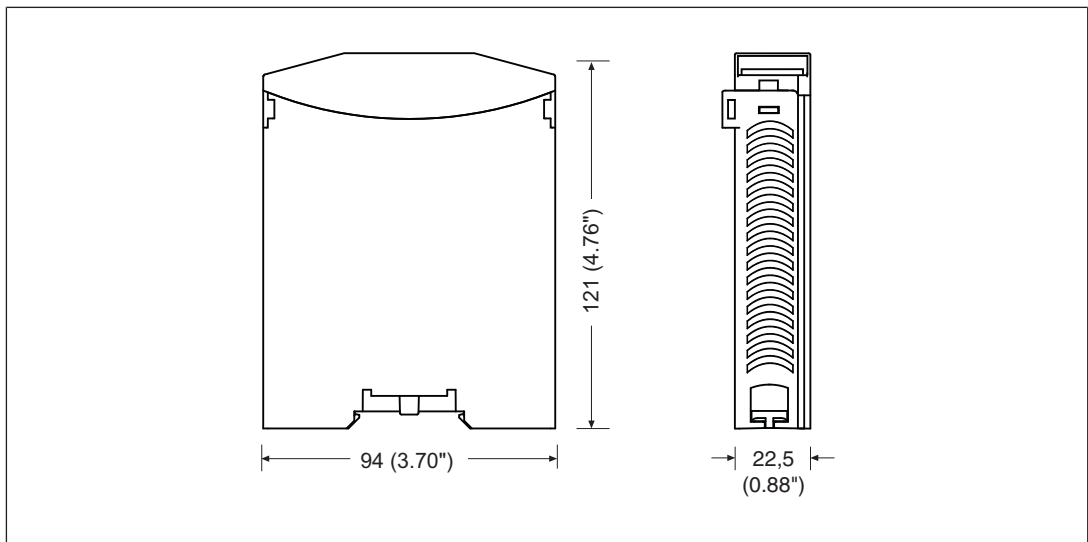

### 5.3 Connecting the base unit and expansion modules

Connect the base unit and the expansion module as described in the operating instructions for the base units.

- ▶ Do **not** connect a terminator to the last expansion module on the left-hand side.
- ▶ Install the expansion module in the position in which it is configured in the PNOZmulti Configurator.

The position of the expansion modules is defined in the PNOZmulti Configurator. The expansion modules are connected to the left or right of the base unit, depending on the type.

Please refer to the document "PNOZmulti System Expansion" for details of the number of modules that can be connected to the base unit and the module types.



## 6 Commissioning

### 6.1 General wiring guidelines

The wiring is defined in the circuit diagram of the PNOZmulti Configurator.

Please note:

- ▶ Information given in the [Technical details](#) [ 22] must be followed.
- ▶ The position of the expansion module is specified in the Hardware configuration of the PNOZmulti Configurator.
- ▶ Use copper wiring with a temperature stability of 75 °C.
- ▶ Two connection terminals are available for each of the supply connections 24 V and 0 V (semiconductor outputs), plus A1 and A2 (power supply). This means that the supply voltage can be looped through several connections. When the supply voltage is looped, the current at each terminal may not exceed 3 A.
- ▶ The max. cable length between two link modules may be max. 1000 m.

Please note:

When connecting to a PNOZ ml1p with a version < 2.0, the cable length may be max. 100 m. The reduced cable length must be configured in the PNOZmulti Configurator.

- ▶ Connect the inputs and outputs from two PNOZ ml1p with a 4-core shielded cable. The cables must be twisted in pairs.
- ▶ Note the crossover cabling, e.g. CA+ with CB+.
- ▶ The cables must be classified into a minimum of Category 5 in accordance with ISO/IEC 11801.
- ▶ You can use ready-made cable from Pilz to connect two PNOZ ml1p. The plug-in connection terminals are either designed as cage clamp terminals or screw terminals (see order reference).
- ▶ Cable shield:
  - Please note: Always connect the shield to both link modules (**Shield** terminal).
  - The shield of the connection cable may only be connected to the **Shield** terminals on both PNOZ ml1p. Do **not** connect the shield to the equipotential bonding bar, for example.



#### CAUTION!

Only connect and disconnect the expansion module when the supply voltage is switched off.

## 6.2 Download modified project to the PNOZmulti system

As soon as an additional expansion module has been connected to the system, the project must be amended in the PNOZmulti Configurator and downloaded back into the base unit. Proceed as described in the operating manual for the base unit.



### NOTICE

For the commissioning and after every user program change, you must check whether the safety devices are functioning correctly.

## 6.3 Connection

Supply voltage	AC	DC
	/	

### Connection of two PNOZmulti base units via the module PNOZ ml1p

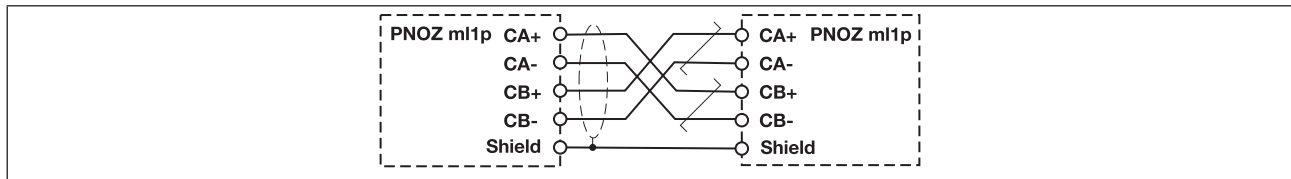

## 6.4 Connection examples

### 6.4.1 Example: Series connection of 3 base units

Reaction time  $t_{SUM}$  between base unit Base 1 and Base 2:

Input delay  $t_{ON}$  at I3 and I6 + data transmission time  $1 * t_{BUS}$  through link module + switch-off delay  $t_{COND}$  of the semiconductor output at O0

$$t_{SUM} = t_{ON} + (n * t_{BUS}) + t_{COND}$$

$$t_{SUM} = 4 \text{ ms} + (1 * 35 \text{ ms}) + 30 \text{ ms} = 69 \text{ ms}$$

Reaction time  $t_{SUM}$  between base unit Base 1 and Base 3:

Input delay  $t_{ON}$  at I3 and I6 + data transmission time  $2 * t_{BUS}$  through link modules + switch-off delay  $t_{COND}$  of the semiconductor output at O1

$$t_{SUM} = t_{ON} + (n * t_{BUS}) + t_{COND}$$

$$t_{SUM} = 4 \text{ ms} + (2 * 35 \text{ ms}) + 30 \text{ ms} = 104 \text{ ms}$$

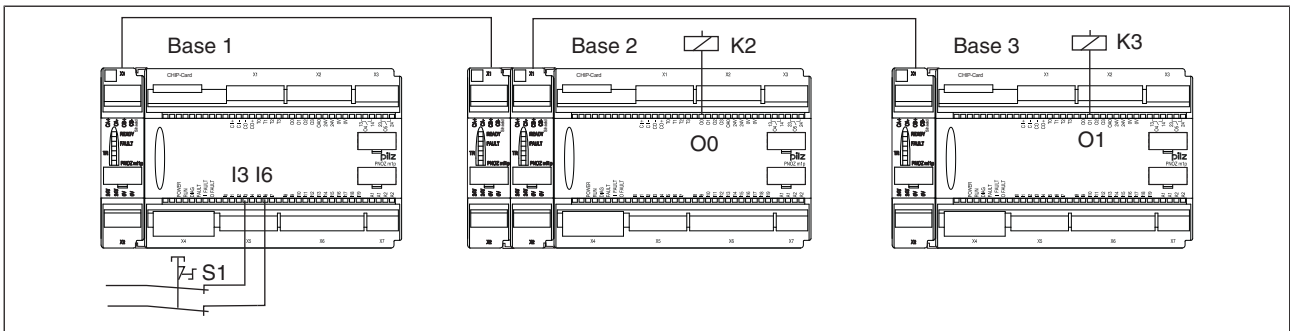

### 6.4.2 Example: Connection of 5 base units

The reaction times are calculated in the same way as application example 1. After pressing S1 on Base 1, the semiconductor outputs switch after the following reaction times  $t_{SUM}$ :

O0 on Base 1: 69 ms

O1 on Base 3: 104 ms

O0 on Base 4: 139 ms

O0 on Base 5: 104 ms

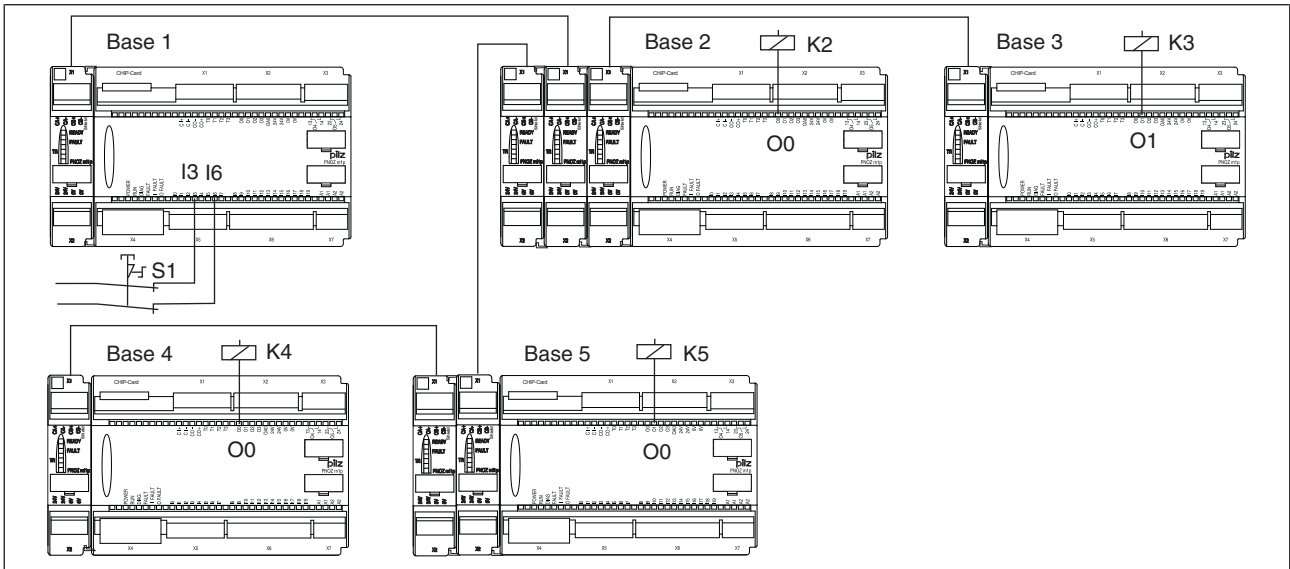



## 7 Operation







When the supply voltage is switched on, the PNOZmulti copies the configuration from the chip card.

The PNOZmulti safety system is ready for operation when the "POWER" and "RUN" LEDs on the base unit and the "READY" LED on the PNOZ ml1p are lit continuously.

### 7.1 LED indicators

#### Legend

-  LED on
-  LED flashes
-  LED off

LED	LED status	Meaning
READY		Green The unit is ready for operation
		The unit is not ready for operation
FAULT		Red External error
		Red Internal error
		No fault
TR		Yellow Connection to another PNOZ ml1p available
		No connection to another PNOZ ml1p

### 7.2 Fault detection

Each base unit contains information about

- ▶ its own link module (in order, defective, no supply voltage)
- ▶ the status of the connection (yes, no)
- ▶ the operating status of the connected base unit (RUN, STOP)

When the connection is interrupted, the base units switch the virtual inputs to zero. The base units remains in a RUN condition.

Defective link module:

- ▶ The corresponding base unit switches to a STOP condition. The virtual outputs on the link module are set to zero.
- ▶ The connected base unit remains in a RUN condition.

## 8 Technical details

<b>General</b>	<b>773540</b>	<b>773545</b>
Certifications	BG, CCC, CE, EAC (Eurasian), KCC, TÜV, cULus Listed	BG, CCC, CE, EAC (Eurasian), TÜV, cULus Listed
<b>Electrical data</b>	<b>773540</b>	<b>773545</b>
Supply voltage		
for	<b>Module supply</b>	<b>Module supply</b>
Voltage	<b>24 V</b>	<b>24 V</b>
Kind	<b>DC</b>	<b>DC</b>
Voltage tolerance	<b>-15 %/+20 %</b>	<b>-15 %/+20 %</b>
Output of external power supply (DC)	<b>5 W</b>	<b>5 W</b>
Residual ripple DC	<b>5 %</b>	<b>5 %</b>
Status indicator	<b>LED</b>	<b>LED</b>
<b>Virtual inputs</b>	<b>773540</b>	<b>773545</b>
Number of virtual inputs	<b>32</b>	<b>32</b>
<b>Virtual outputs</b>	<b>773540</b>	<b>773545</b>
Number of virtual outputs	<b>32</b>	<b>32</b>
<b>Times</b>	<b>773540</b>	<b>773545</b>
Switch-on delay	<b>5 s</b>	<b>5 s</b>
Supply interruption before de-energisation	<b>20 ms</b>	<b>20 ms</b>
Max. data transmission time	<b>35 ms</b>	<b>35 ms</b>
<b>Environmental data</b>	<b>773540</b>	<b>773545</b>
Ambient temperature		
In accordance with the standard	<b>EN 60068-2-14</b>	<b>EN 60068-2-14</b>
Temperature range	<b>0 - 60 °C</b>	<b>-25 - 60 °C</b>
Storage temperature		
In accordance with the standard	<b>EN 60068-2-1/-2</b>	<b>EN 60068-2-1/-2</b>
Temperature range	<b>-25 - 70 °C</b>	<b>-25 - 70 °C</b>
Climatic suitability		
In accordance with the standard	<b>EN 60068-2-30, EN 60068-2-78</b>	<b>EN 60068-2-30, EN 60068-2-78</b>
Humidity	<b>93 % r. h. at 40 °C</b>	<b>93 % r. h. at 40 °C</b>
Condensation during operation	<b>Not permitted</b>	<b>Short-term</b>
EMC	<b>EN 61131-2</b>	<b>EN 61131-2</b>
Vibration		
In accordance with the standard	<b>EN 60068-2-6</b>	<b>EN 60068-2-6</b>
Frequency	<b>10 - 150 Hz</b>	<b>5 - 500 Hz</b>
Acceleration	<b>1g</b>	<b>1g</b>
Broadband noise		
In accordance with the standard	<b>–</b>	<b>EN 60068-2-64</b>
Frequency	<b>–</b>	<b>5 - 500 Hz</b>
Acceleration	<b>–</b>	<b>1,9grms</b>

<b>Environmental data</b>	<b>773540</b>	<b>773545</b>
Shock stress		
In accordance with the standard	<b>EN 60068-2-27</b>	<b>EN 60068-2-27</b>
Acceleration	<b>15g</b>	<b>15g</b>
Duration	<b>11 ms</b>	<b>11 ms</b>
Max. operating height above sea level	<b>2000 m</b>	<b>2000 m</b>
Airgap creepage		
In accordance with the standard	<b>EN 61131-2</b>	<b>EN 61131-2</b>
Overvoltage category	<b>III</b>	<b>III</b>
Pollution degree	<b>2</b>	<b>2</b>
Rated insulation voltage	<b>30 V</b>	<b>30 V</b>
Protection type		
In accordance with the standard	<b>EN 60529</b>	<b>EN 60529</b>
Mounting area (e.g. control cabinet)	<b>IP54</b>	<b>IP54</b>
Housing	<b>IP20</b>	<b>IP20</b>
Terminals	<b>IP20</b>	<b>IP20</b>
<b>Mechanical data</b>	<b>773540</b>	<b>773545</b>
Mounting position	<b>horizontally on mounting rail</b>	<b>horizontally on mounting rail</b>
DIN rail		
Top hat rail	<b>35 x 7,5 EN 50022</b>	<b>35 x 7,5 EN 50022</b>
Recess width	<b>27 mm</b>	<b>27 mm</b>
Max. cable length between two link modules	<b>1 km</b>	<b>1 km</b>
Material		
Bottom	<b>PPO UL 94 V0</b>	<b>PPO UL 94 V0</b>
Front	<b>ABS UL 94 V0</b>	<b>ABS UL 94 V0</b>
Connection type	<b>Spring-loaded terminal, screw terminal</b>	<b>Spring-loaded terminal, screw terminal</b>
Conductor cross section with screw terminals		
1 core flexible	<b>0,25 - 1,5 mm<sup>2</sup>, 24 - 16 AWG</b>	<b>0,25 - 1,5 mm<sup>2</sup>, 24 - 16 AWG</b>
2 core with the same cross section, flexible without crimp connectors or with TWIN crimp connectors	<b>0,25 - 0,75 mm<sup>2</sup>, 24 - 20 AWG</b>	<b>0,25 - 0,75 mm<sup>2</sup>, 24 - 20 AWG</b>
Torque setting with screw terminals	<b>0,25 Nm</b>	<b>0,25 Nm</b>
Stripping length with screw terminals	<b>7 mm</b>	<b>7 mm</b>
Conductor cross section with spring-loaded terminals		
1 core flexible without crimp connector	<b>0,25 - 1,5 mm<sup>2</sup>, 24 - 16 AWG</b>	<b>0,25 - 1,5 mm<sup>2</sup>, 24 - 16 AWG</b>
1 core flexible with crimp connector	<b>0,25 - 0,75 mm<sup>2</sup>, 24 - 20 AWG</b>	<b>0,25 - 0,75 mm<sup>2</sup>, 24 - 20 AWG</b>
Spring-loaded terminals: Terminal points per connection	<b>1</b>	<b>1</b>

<b>Mechanical data</b>	<b>773540</b>	<b>773545</b>
Stripping length with spring-loaded terminals	<b>9 mm</b>	<b>9 mm</b>
Dimensions		
Height	<b>94 mm</b>	<b>94 mm</b>
Width	<b>22,5 mm</b>	<b>22,5 mm</b>
Depth	<b>121 mm</b>	<b>121 mm</b>
Weight	<b>129 g</b>	<b>135 g</b>

Where standards are undated, the 2020-07 latest editions shall apply.



## 8.1 Safety characteristic data



### NOTICE

You must comply with the safety characteristic data in order to achieve the required safety level for your plant/machine.

Operating mode	EN ISO 13849-1: 2015 PL	EN ISO 13849-1: 2015 Category	EN 62061 SIL CL	EN 62061 PFH <sub>0</sub> [1/h]	IEC 61511 SIL	IEC 61511 PFD	EN ISO 13849-1: 2015 T <sub>M</sub> [year]
2-channel	PL e	Cat. 4	SIL CL 3	8,82E-09	SIL 3	3,86E-05	20

Explanatory notes for the safety-related characteristic data:

- ▶ The SIL CL value in accordance with EN 62061 corresponds to the SIL value in accordance with EN 61508.
- ▶ T<sub>M</sub> is the maximum mission time in accordance with EN ISO 13849-1. The value also applies as the retest interval in accordance with EN 61508-6 and IEC 61511 and as the proof test interval and mission time in accordance with EN 62061.

All the units used within a safety function must be considered when calculating the safety characteristic data.



### INFORMATION

A safety function's SIL/PL values are **not** identical to the SIL/PL values of the units that are used and may be different. We recommend that you use the PAscal software tool to calculate the safety function's SIL/PL values.

## 9 Order reference

### 9.1 Product

Product type	Features	Order No.
PNOZ ml1p	Link Module	773 540
PNOZ ml1p coated version	Link module, coated version	773 545

### 9.2 Accessories

#### Terminator, jumper

Product type	Features	Order No.
PNOZmulti bus terminator	Terminator	779 110
PNOZmulti bus terminator coated	Terminator, coated version	779 112
KOP-XE	Jumper	774 639
KOP-XE coated	Jumper, coated version	774 640

#### Cable

Product type	Features	Order no.
PNOZ mli1p 5m screw	Cable, 5-pin, shielded, screw terminal, 5 m	773 890
PNOZ mli1p 10m screw	Cable, 5-pin, shielded, screw terminal, 10 m	773 891
PNOZ mli1p 50m screw	Cable, 5-pin, shielded, screw terminal, 50 m	773 892
PNOZ mli1p 5m spring	Cable, 5-pin, shielded, spring-loaded terminal, 5 m	773 893
PNOZ mli1p 10m spring	Cable, 5-pin, shielded, spring-loaded terminal, 10 m	773 894
PNOZ mli1p 50m spring	Cable, 5-pin, shielded, spring-loaded terminal, 50 m	773 895
PNOZ mli1p 1.5m spring	Cable, 5-pin, shielded, spring-loaded terminal, 1.5 m	773 896
PNOZ mli1p 1.5m screw	Cable, 5-pin, shielded, screw terminal, 1.5 m	773 897
SafetyNET p Cable	SafetyNET p cable, 1 - 500 m	380 000

#### Connection terminals

Product type	Features	Order No.
Set spring terminals	1 set of spring-loaded terminals	783 400
Set screw terminals	1 set of screw terminals	793 400

# ► Support

Technical support is available from Pilz round the clock.

## Americas

**Brazil**  
+55 11 97569-2804

**Canada**  
+1 888 315 7459

**Mexico**  
+52 55 5572 1300

**USA (toll-free)**  
+1 877-PILZUSA (745-9872)

## Asia

**China**  
+86 21 60880878-216

**Japan**  
+81 45 471-2281

**South Korea**  
+82 31 778 3300

## Australia

+61 3 95600621

## Europe

**Austria**  
+43 1 7986263-0

**Belgium, Luxembourg**  
+32 9 3217570

**France**  
+33 3 88104003

**Germany**  
+49 711 3409-444

**Ireland**  
+353 21 4804983

**Italy, Malta**  
+39 0362 1826711

## Scandinavia

+45 74436332

## Spain

+34 938497433

## Switzerland

+41 62 88979-32

## The Netherlands

+31 347 320477

## Turkey

+90 216 5775552

## United Kingdom

+44 1536 462203

## You can reach our international hotline on:

+49 711 3409-444  
support@pilz.com

Pilz develops environmentally-friendly products using ecological materials and energy-saving technologies. Offices and production facilities are ecologically designed, environmentally-aware and energy-saving. So Pilz offers sustainability, plus the security of using energy-efficient products and environmentally-friendly solutions.

*Energy*  
saving by Pilz



We are represented internationally. Please refer to our homepage [www.pilz.com](http://www.pilz.com) for further details or contact our headquarters.

Headquarters: Pilz GmbH & Co. KG, Felix-Wankel-Straße 2, 73760 Ostfildern, Germany  
Telephone: +49 711 3409-0, Telefax: +49 711 3409-133, E-Mail: [info@pilz.com](mailto:info@pilz.com), Internet: [www.pilz.com](http://www.pilz.com)

**PILZ**  
THE SPIRIT OF SAFETY

21575-EN-08, 2020-07 Printed in Germany  
© Pilz GmbH & Co. KG, 2019

CECE®, CHRE®, CMSE®, InduraNET p®, Leansafe®, Master of Safety®, Master of Security®, PAS4000®, PAScall®, PASconfig®, Pilz®, PTT®, PLID®, PMCPirimo®, PMCPiritego®, PMCTendo®, PMD®, PMJ®, PNOZ®, PRBT®, PRCM®, PRCM®, PSEN®, PSS®, PVS®, SafetyBUS p®, SafetyEYE®, SafetyNET p®, THE SPIRIT OF SAFETY® are registered and protected trademarks of Pilz GmbH & Co. KG in some countries. We would point out that product features may vary from the details stated in this document, depending on the status at the time of publication and the scope of the equipment. We accept no responsibility for the validity, accuracy and entirety of the text and graphics presented in this information. Please contact our Technical Support if you have any questions.