



PNOZ mmc6p

PILZ
THE SPIRIT OF SAFETY

- ▶ Configurable, safe compact controllers PNOZmulti Mini

This document is the original document.

Where unavoidable, for reasons of readability, the masculine form has been selected when formulating this document. We do assure you that all persons are regarded without discrimination and on an equal basis.

All rights to this documentation are reserved by Pilz GmbH & Co. KG. Copies may be made for the user's internal purposes. Suggestions and comments for improving this documentation will be gratefully received.

Pilz®, PIT®, PMI®, PNOZ®, Primo®, PSEN®, PSS®, PVIS®, SafetyBUS p®, SafetyEYE®, SafetyNET p®, the spirit of safety® are registered and protected trademarks of Pilz GmbH & Co. KG in some countries.



SD means Secure Digital

1	Introduction	4
1.1	Validity of documentation	4
1.2	Using the documentation	4
1.3	Definition of symbols	4
2	Overview	6
2.1	Scope of supply	6
2.2	Unit features	6
2.3	Front view	7
3	Safety	8
3.1	Intended use	8
3.2	System requirements	8
3.3	Safety regulations	9
3.3.1	Use of qualified personnel	9
3.3.2	Warranty and liability	9
3.3.3	Disposal	9
3.3.4	For your safety	9
4	Function description	10
4.1	Operation	10
4.2	Input and output data	10
4.3	Assigning the inputs/outputs in the PNOZmulti Configurator to the CANopen inputs/outputs ..	10
4.4	Block diagram	11
5	Installation	12
5.1	General installation guidelines	12
5.2	Dimensions in mm	12
5.3	Connect the base unit and expansion modules	13
6	Commissioning	14
6.1	General wiring guidelines	14
6.2	Connecting the supply voltage	14
6.3	CANopen interface	15
6.3.1	CANopen termination	15
6.4	Setting the transmission rate	15
6.5	Setting the station address	16
6.6	Download modified project to the PNOZmulti safety system	16
6.7	Connection example	17
7	Operation	18
7.1	Messages	18
8	Technical details	19
9	Order reference	21
9.1	Product	21
9.2	Accessories	21

1 Introduction

1.1 Validity of documentation

This documentation is valid for the product PNOZ mmc6p. It is valid until new documentation is published.

This operating manual explains the function and operation, describes the installation and provides guidelines on how to connect the product.

1.2 Using the documentation

This document is intended for instruction. Only install and commission the product if you have read and understood this document. The document should be retained for future reference.

1.3 Definition of symbols

Information that is particularly important is identified as follows:



DANGER!

This warning must be heeded! It warns of a hazardous situation that poses an immediate threat of serious injury and death and indicates preventive measures that can be taken.



WARNING!

This warning must be heeded! It warns of a hazardous situation that could lead to serious injury and death and indicates preventive measures that can be taken.



CAUTION!

This refers to a hazard that can lead to a less serious or minor injury plus material damage, and also provides information on preventive measures that can be taken.



NOTICE

This describes a situation in which the product or devices could be damaged and also provides information on preventive measures that can be taken. It also highlights areas within the text that are of particular importance.



INFORMATION

This gives advice on applications and provides information on special features.

2 Overview

2.1 Scope of supply

- ▶ Expansion module PNOZ mmc6p
- ▶ Jumper

2.2 Unit features

Application of the product PNOZ mmc6p:

Expansion module for connection to a base unit from the configurable control system PNOZmulti Mini

The product has the following features:

- ▶ Can be configured in the PNOZmulti Configurator
- ▶ Connection for CANopen
- ▶ Station addresses from 0 ... 99, selected via rotary switch
- ▶ Transmission rate selected via rotary switch (1 MBit/s, 10 kbit/s, 125 kBit/s, 20 kbit/s, 250 kBit/s, 50 kbit/s, 500 kBit/s, 800 kbit/s)
- ▶ Status indicators for communication with CANopen and for errors
- ▶ 24 virtual inputs and outputs on the control system PNOZmulti can be defined in the PNOZmulti Configurator for communication with the fieldbus CANopen . The number of inputs and outputs can be extended to 128. Please note that when the extended inputs and outputs 24 - 127 are used they have different properties (see document entitled "Communication Interfaces").
- ▶ Max. 1 PNOZ mmc6p can be connected to the base unit
- ▶ Plug-in connection terminals:
Either spring-loaded terminal or screw terminal available as an accessory (see Order references for accessories).
- ▶ Please refer to the document "PNOZmulti System Expansion" for details of the base units PNOZmulti Mini that can be connected.

2.3 Front view

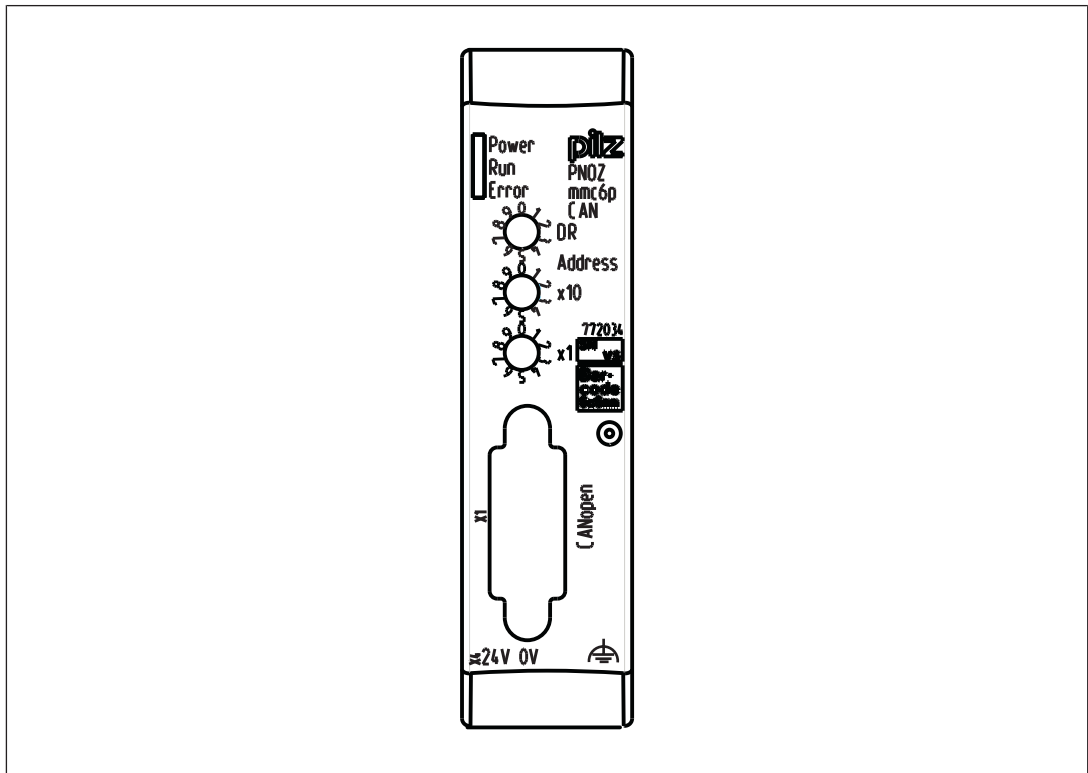

Legend:

- ▶ X4: 0 V, 24 V:
Supply connections
- ▶ X1: CANopen interface (male 9-pin D-Sub connector)
- ▶ : Functional earth
- ▶ LED:
 - Power
 - Run
 - Error

3 Safety

3.1 Intended use

The fieldbus module PNOZ mmc6p is an expansion module of the configurable control system PNOZmulti Mini. It is used for communication between the configurable control system PNOZmulti and CANopen.

CANopen is designed for fast data exchange at field level. The expansion module PNOZ mmc6p is a passive CANopen subscriber (Slave). The basic communication functions with CANopen conform to the guidelines of the CANopen User Group CiA DS-301 V4.2.0. The central controller (master) reads input information from the slaves and writes output information to the slaves as part of each cycle. As well as the cyclical transfer of usable data, the expansion module PNOZ mmc6p can also be used for diagnostic and commissioning functions. Data traffic is monitored on the Master/Slave side.

The expansion module may only be connected to a base unit PNOZmulti Mini (for details of the base units PNOZmulti Mini

that can be connected, refer to the document "PNOZmulti System Expansion").

The configurable small control systems PNOZmulti are used for the safety-related interruption of safety circuits and are designed for use in:

- ▶ E-STOP equipment
- ▶ Safety circuits in accordance with VDE 0113 Part 1 and EN 60204-1

The expansion module may not be used for safety-related functions.

Improper use

The following is deemed improper use in particular

- ▶ Any component, technical or electrical modification to the product,
- ▶ Use of the product outside the areas described in this operating manual,
- ▶ Use of the product outside the technical details (see [Technical details](#)  19]).



NOTICE **EMC-compliant electrical installation**

The product is designed for use in an industrial environment. The product may cause interference if installed in other environments. If installed in other environments, measures should be taken to comply with the applicable standards and directives for the respective installation site with regard to interference.

3.2 System requirements

Please refer to the "Product Modifications PNOZmulti" document in the "Version overview" section for details of which versions of the base unit and PNOZmulti Configurator can be used for this product.

3.3 Safety regulations

3.3.1 Use of qualified personnel

The products may only be assembled, installed, programmed, commissioned, operated, maintained and decommissioned by competent persons.

A competent person is someone who, because of their training, experience and current professional activity, has the specialist knowledge required to test, assess and operate the work equipment, devices, systems, plant and machinery in accordance with the general standards and guidelines for safety technology.

It is the company's responsibility only to employ personnel who

- ▶ Are familiar with the basic regulations concerning health and safety / accident prevention,
- ▶ Have read and understood the information provided in this description under "Safety",
- ▶ And have a good knowledge of the generic and specialist standards applicable to the specific application.

3.3.2 Warranty and liability

All claims to warranty and liability will be rendered invalid if

- ▶ The product was used contrary to the purpose for which it is intended,
- ▶ Damage can be attributed to not having followed the guidelines in the manual,
- ▶ Operating personnel are not suitably qualified,
- ▶ Any type of modification has been made (e.g. exchanging components on the PCB boards, soldering work etc.).

3.3.3 Disposal

- ▶ When decommissioning, please comply with local regulations regarding the disposal of electronic devices (e.g. Electrical and Electronic Equipment Act).

3.3.4 For your safety

The unit meets all the necessary conditions for safe operation. However, you should always ensure that the following safety requirements are met:

- ▶ This operating manual only describes the basic functions of the unit. The expanded functions are described in the PNOZmulti Configurator's online help. Only use these functions once you have read and understood the documentations.
- ▶ Do not open the housing or make any unauthorised modifications.
- ▶ Please make sure you shut down the supply voltage when performing maintenance work (e.g. exchanging contactors).

4 Function description

4.1 Operation

The virtual inputs and outputs that are to be transferred via CANopen are selected and configured in the PNOZmulti Configurator. The base unit and the expansion module PNOZ mmc6p are connected via a jumper. The station address and the transmission rate are set using rotary switches. After the supply voltage is switched on or the PNOZmulti control system is reset, the expansion module PNOZ mmc6p is configured and started automatically.

LEDs indicate the status of the expansion module on CANopen.

The configuration is described in detail in the PNOZmulti Configurator's online help.

4.2 Input and output data

The data is structured as follows:

▶ Input area

The inputs are defined in the master and transferred to the PNOZmulti. Each input has a number, e.g. input bit 4 of byte 1 has the number i12.

▶ Output range

The outputs are defined in the PNOZmulti Configurator. Each output that is used is given a number there, e.g. o0, o5... The status of output o0 is stored in bit 0 of byte 0; the status of output o5 is stored in bit 5 of byte 0 etc.

▶ Output range only: Byte 3

Bits 0 ... 4: Status of LEDs on the PNOZmulti

- Bit 0: OFAULT
- Bit 1: IFAULT
- Bit 2: FAULT
- Bit 3: DIAG
- Bit 4: RUN

Bit 5: Data is being exchanged.

Detailed information on data exchange (tables, segments) is available in the document "Communication Interfaces" in the section entitled "Fieldbus modules".

4.3 Assigning the inputs/outputs in the PNOZmulti Configurator to the CANopen inputs/outputs

Virtual inputs on PNOZmulti Configurator	i0 ... i7	i8 ... i15	i16 ... i23
Input data CANopen	Byte 0: Bits 0 ... 7	Byte 1: Bits 0 ... 7	Byte 2: Bits 0 ... 7
Virtual outputs on PNOZmulti Configurator	o0 ... o7	o8 ... o15	o16 ... o23
Output data CANopen	Byte 0: Bits 0 ... 7	Byte 1: Bits 0 ... 7	Byte 2: Bits 0 ... 7

The number of virtual inputs and outputs can be extended to 128 (see document "Communication Interfaces" in the section entitled "Fieldbus modules")

4.4 Block diagram

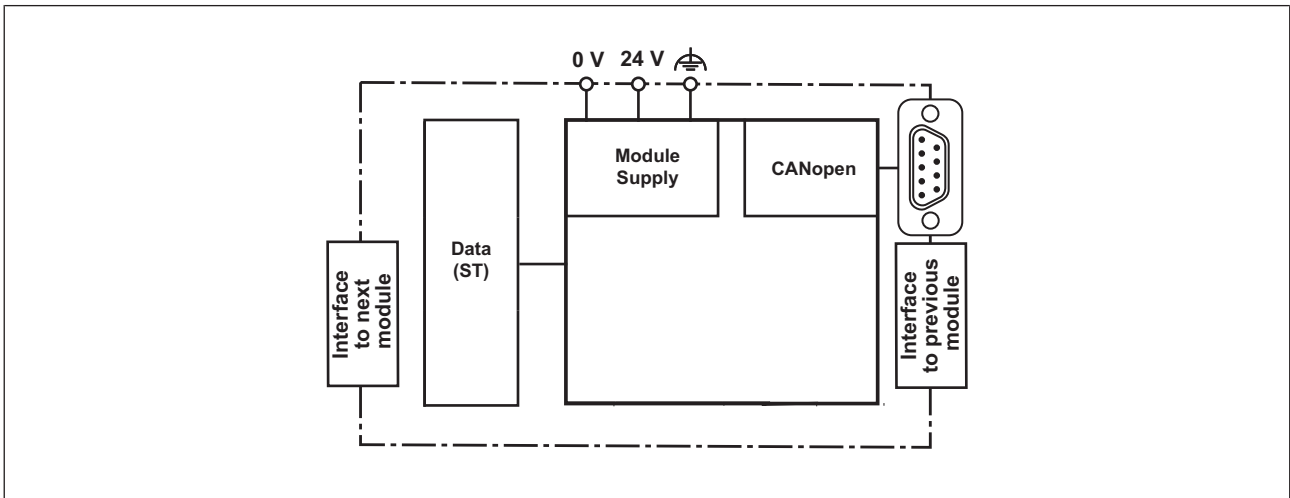

5 Installation

5.1 General installation guidelines

- ▶ The unit should be installed in a control cabinet with a protection type of at least IP54.
- ▶ Fit the safety system to a horizontal mounting rail. The venting slots must face upwards and downwards. Other mounting positions could destroy the safety system.
- ▶ Use the notch on the rear of the unit to attach it to a mounting rail.
- ▶ In environments exposed to heavy vibration, the unit should be secured using a fixing element (e.g. retaining bracket or end angle).
- ▶ Push the unit upwards or downwards before lifting it from the mounting rail.
- ▶ To comply with EMC requirements, the mounting rail must have a low impedance connection to the control cabinet housing.
- ▶ The ambient temperature in the control cabinet must not exceed the figure stated in the technical details. otherwise air conditioning may be required.



NOTICE

Damage due to electrostatic discharge!

Electrostatic discharge can damage components. Ensure against discharge before touching the product, e.g. by touching an earthed, conductive surface or by wearing an earthed armband.

5.2 Dimensions in mm

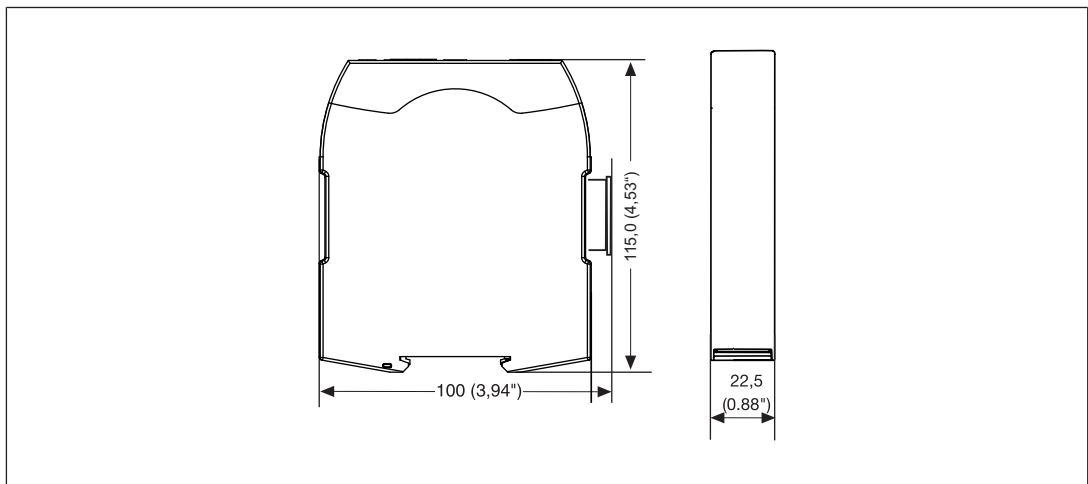

5.3 **Connect the base unit and expansion modules**

Connect the base unit and the expansion module as described in the operating instructions for the base units.

- ▶ Connect the black/yellow terminator to the expansion module.
- ▶ Install the expansion module in the position in which it is configured in the PNOZmulti Configurator.

The position of the expansion modules is defined in the PNOZmulti Configurator. The expansion modules are connected to the left or right of the base unit, depending on the type.

Please refer to the document "PNOZmulti System Expansion" for details of the number of modules that can be connected to the base unit and the module types.

6 Commissioning

6.1 General wiring guidelines

The wiring is defined in the circuit diagram of the PNOZmulti Configurator.

Please note:

- ▶ Information given in the [Technical details \[19\]](#) must be followed.
- ▶ The position of the expansion module is specified in the Hardware configuration of the PNOZmulti Configurator.
- ▶ Use copper wiring with a temperature stability of 75 °C.
- ▶ External measures must be used to connect the  terminal to the function earth (e.g. mounting rail).
- ▶ Always connect the mounting rail to the protective earth via an earthing terminal. This will be used to dissipate hazardous voltages in the case of a fault.
- ▶ The power supply must meet the regulations for extra low voltages with protective electrical separation (SELV, PELV).



CAUTION!

Only connect and disconnect the expansion module when the supply voltage is switched off.



NOTICE

When installing, you must refer to the guidelines of the CANopenUser Group.

6.2 Connecting the supply voltage

Connect the supply voltage to the fieldbus module:

- ▶ **24 V** terminal: + 24 VDC
- ▶ **0 V** terminal: 0 V
- ▶ Protect the supply voltage as follows:
 - Circuit breaker, characteristic C - 6 A
 - or
 - Blow-out fuse, slow, 6A

6.3 CANopen interface

The connection to CANopen is made via a male 9-pin D-Sub connector.

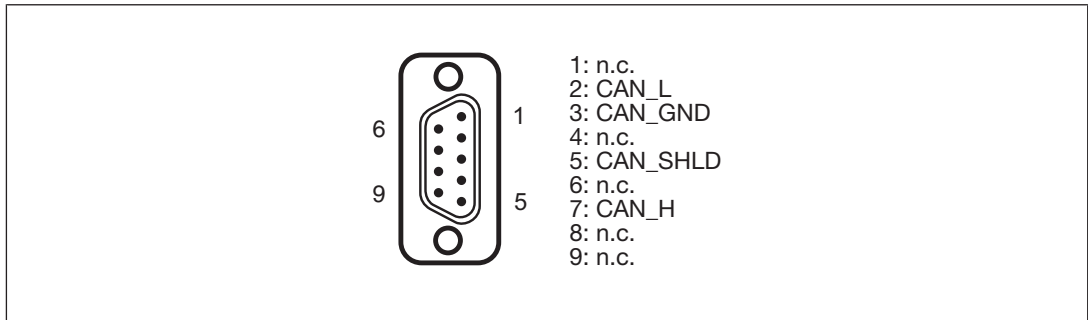

n.c. = not connected

Please note the following when connecting to CANopen:

- ▶ Only use metal plugs or metallised plastic plugs
- ▶ Twisted pair, screened cable must be used to connect the interfaces

6.3.1 CANopen termination

To minimise cable reflection and to guarantee a defined rest signal on the transmission line, CANopen must be terminated at both ends.

6.4 Setting the transmission rate



- ▶ On the upper rotary switch DR, use a small screwdriver to set the transmission rate (in the example, "3" corresponds to 50 kBit/s).

Switch setting	0	1	2	3	4	5	6	7	8	9
Transmission rate	-	10 kBit/s	20 kBit/s	50 kBit/s	125 kBit/s	250 kBit/s	500 kBit/s	800 kBit/s	1 MBit/s	-



INFORMATION

The transmission rate cannot be changed during operation.

6.5 Setting the station address

The station address of the expansion module PNOZ mmc6p is set between 0 ... 99 (decimal) via two rotary switches x1 and x10.

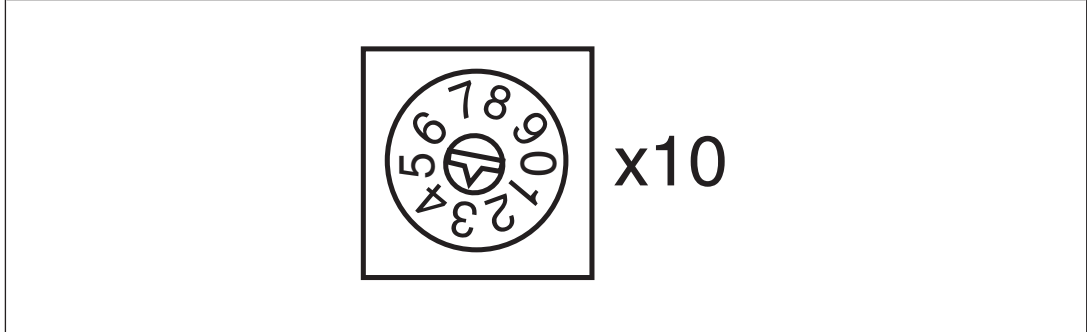

- ▶ On the middle rotary switch x10, use a small screwdriver to set the tens digit for the address ("3" in the example).

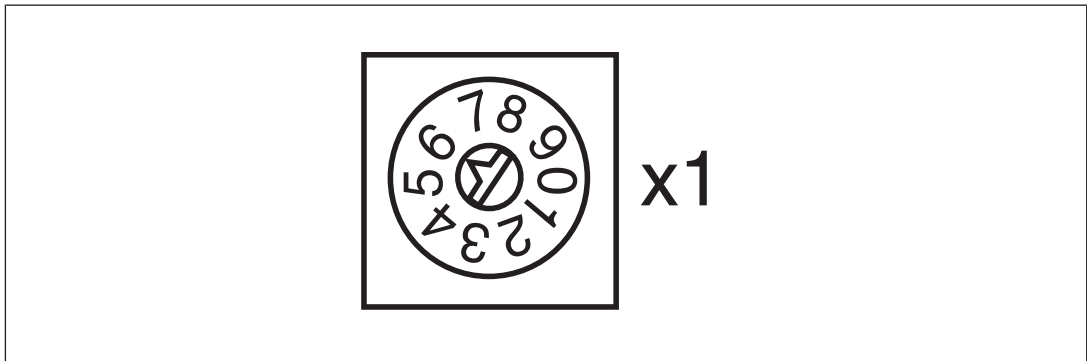

- ▶ On the lower rotary switch x1, set the ones digit for the address ("6" in the example).

Station address 36 is set in the diagrams as an example.

6.6 Download modified project to the PNOZmulti safety system

As soon as an additional expansion module has been connected to the system, the project must be amended in the PNOZmulti Configurator and downloaded back into the base unit. Proceed as described in the operating manual for the base unit.



NOTICE

For the commissioning and after every user program change, you must check whether the safety devices are functioning correctly.

6.7 Connection example

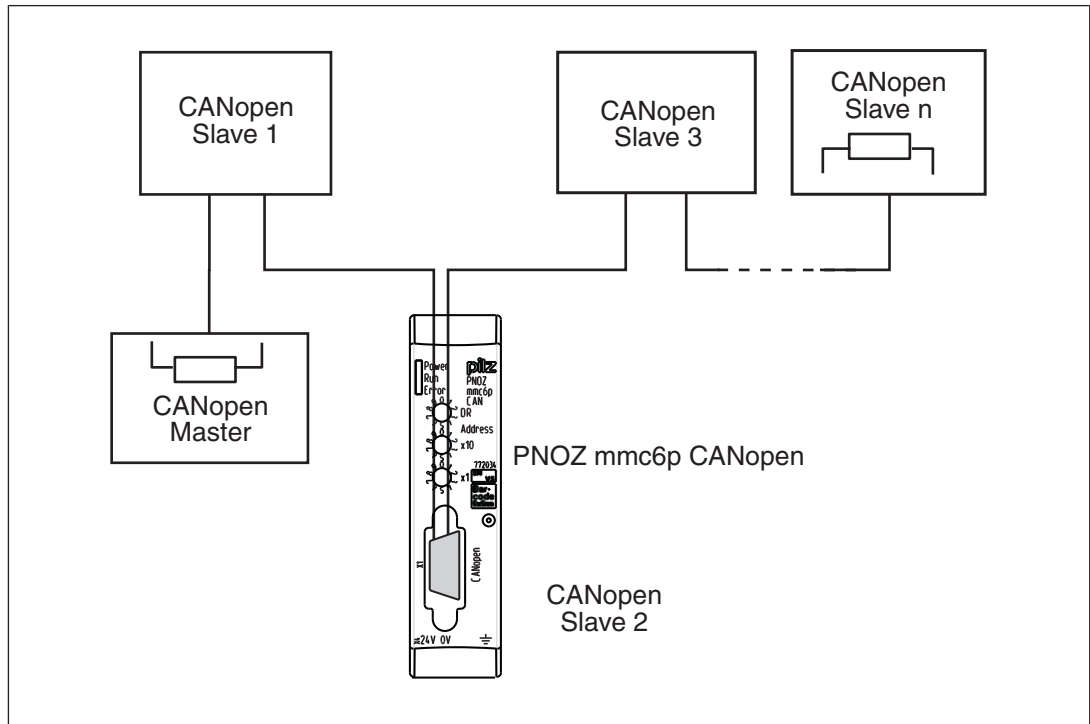

7 Operation



When the supply voltage is switched on, the PNOZmulti copies the configuration from the chip card.











The expansion module PNOZ mmc6p is configured and started automatically. The LEDs "RUN" and "ERR" display the status of the PNOZ mmc6p on CANopen.

If the expansion module PNOZ mmc6p does not receive a configuration from the base unit for a period of 30 s, the expansion module PNOZ mmc6p connects to CANopen and "RUN" status is displayed on CANopen. The error message "External Error" is sent to the Master.

7.1 Messages

Legend

-  LED on
-  LED flashes
-  LED off

LED		Key
PWR		Supply voltage is present
		Supply voltage is not present
RUN		PNOZ mmc6p In "Operational" status
		PNOZ mmc6p In "Stopped" status
		PNOZ mmc6p In "Pre-Operational" status
		No supply voltage or module error detected
ERR		CAN controller is in "Bus off" status
		Error threshold value has been reached, the CAN controller has received too many error telegrams
		Monitoring error, activation of master-slave monitoring error, e.g. heartbeat monitoring
		Error in "Synchronisation" operating status, a synchronisation telegram, e.g. with simultaneous writing on several devices, did not occur within the configured time
		No error

8 Technical details

General	
Certifications	CE, EAC, UKCA, cULus Listed
Electrical data	
Supply voltage	
for	Module supply
Voltage	24 V
Kind	DC
Voltage tolerance	-20 %/+25 %
Output of external power supply (DC)	1,5 W
Status indicator	LED
Fieldbus interface	
Fieldbus interface	CANopen
Device type	Slave
Log	CiA 301 V4.2.0
Station address	0 - 99d
Transmission rates	1 MBit/s, 10 kbit/s, 125 kBit/s, 20 kbit/s, 250 kBit/s, 50 kbit/s, 500 kBit/s, 800 kbit/s
Connection	9-pin D-Sub male connector
Galvanic isolation	yes
Times	
Supply interruption before de-energisation	20 ms
Environmental data	
Ambient temperature	
In accordance with the standard	EN 60068-2-14
Temperature range	0 - 60 °C
Forced convection in control cabinet off	55 °C
Storage temperature	
In accordance with the standard	EN 60068-2-1/-2
Temperature range	-25 - 70 °C
Climatic suitability	
In accordance with the standard	EN 60068-2-30, EN 60068-2-78
Humidity	93 % r. h. at 40 °C
Condensation during operation	Not permitted
Max. operating height above sea level	2000 m
EMC	EN 61131-2
Vibration	
In accordance with the standard	EN 60068-2-6
Frequency	10 - 150 Hz
Acceleration	1g
Shock stress	
In accordance with the standard	EN 60068-2-27
Acceleration	15g
Duration	11 ms

Environmental data	
Airgap creepage	
In accordance with the standard	EN 61131-2
Overvoltage category	II
Pollution degree	2
Rated insulation voltage	30 V
Protection type	
In accordance with the standard	EN 60529
Housing	IP20
Terminals	IP20
Mounting area (e.g. control cabinet)	IP54
Potential isolation	
Potential isolation between	Fieldbus and module voltage
Type of potential isolation	Functional insulation
Rated surge voltage	500 V
Mechanical data	
Mounting position	horizontally on mounting rail
DIN rail	
Top hat rail	35 x 7,5 EN 50022
Recess width	27 mm
Material	
Bottom	PC
Front	PC
Top	PC
Connection type	Spring-loaded terminal, screw terminal
Conductor cross section with screw terminals	
1 core flexible	0,25 - 2,5 mm², 24 - 12 AWG
2 core with the same cross section, flexible without crimp connectors or with TWIN crimp connectors	0,2 - 1,5 mm², 24 - 16 AWG
Torque setting with screw terminals	0,5 Nm
Conductor cross section with spring-loaded terminals:	
Flexible with/without crimp connector	0,2 - 2,5 mm², 24 - 12 AWG
Spring-loaded terminals: Terminal points per connection	2
Stripping length with spring-loaded terminals	9 mm
Dimensions	
Height	100 mm
Width	22,5 mm
Depth	115 mm
Weight	95 g

Where standards are undated, the 2011-09 latest editions shall apply.

9 Order reference

9.1 Product

Product type	Features	Order no.
PNOZ mmc6p	Fieldbus module, CANopen	772 034

9.2 Accessories

Connection terminals

Product type	Features	Order no.
Spring terminals PNOZ mmcxp 1 pc.	Spring-loaded terminals, 1 pieces	783542
Spring terminals PNOZ mmcxp 10 pcs.	Spring-loaded terminals, 10 pieces	783543
Screw terminals PNOZ mmcxp 1 pc.	Screw terminals, 1 piece	793542
Screw terminals PNOZ mmcxp 10 pcs.	Screw terminals, 10 pieces	793543

Terminator, jumper

Product type	Features	Order No.
PNOZ s terminator plug	Terminator, yellow, 10 pieces	750 010
PNOZ s connector	Jumper, 10 pieces	750 020

► Support

Technical support is available from Pilz round the clock.

Americas

Brazil

+55 11 97569-2804

Canada

+1 888 315 7459

Mexico

+52 55 5572 1300

USA (toll-free)

+1 877-PILZUSA (745-9872)

Asia

China

+86 21 60880878-216

Japan

+81 45 471-2281

South Korea

+82 31 778 3300

Australia and Oceania

Australia

+61 3 95600621

New Zealand

+64 9 6345350

Europe

Austria

+43 1 7986263-0

Belgium, Luxembourg

+32 9 3217570

France

+33 3 88104003

Germany

+49 711 3409-444

Ireland

+353 21 4804983

Italy, Malta

+39 0362 1826711

Scandinavia

+45 74436332

Spain

+34 938497433

Switzerland

+41 62 88979-32

The Netherlands

+31 347 320477

Turkey

+90 216 5775552

United Kingdom

+44 1536 462203

**You can reach our
international hotline on:**

+49 711 3409-222
support@pilz.com

Pilz develops environmentally-friendly products using ecological materials and energy-saving technologies. Offices and production facilities are ecologically designed, environmentally-aware and energy-saving. So Pilz offers sustainability, plus the security of using energy-efficient products and environmentally-friendly solutions.



We are represented internationally. Please refer to our homepage www.pilz.com for further details or contact our headquarters.

Headquarters: Pilz GmbH & Co. KG, Felix-Wankel-Straße 2, 73760 Ostfildern, Germany
Telephone: +49 711 3409-0, Telefax: +49 711 3409-133, E-Mail: info@pilz.com, Internet: www.pilz.com

PILZ

THE SPIRIT OF SAFETY