



## PNOZ ms4p

**PILZ**  
THE SPIRIT OF SAFETY

- ▶ Configurable, safe small controllers PNOZmulti Classic

This document is the original document.

All rights to this documentation are reserved by Pilz GmbH & Co. KG. Copies may be made for the user's internal purposes. Suggestions and comments for improving this documentation will be gratefully received.

Source code from third-party manufacturers or open source software has been used for some components. The relevant licence information is available on the Internet on the Pilz homepage.

Pilz®, PIT®, PMI®, PNOZ®, Primo®, PSEN®, PSS®, PVIS®, SafetyBUS p®, SafetyEYE®, SafetyNET p®, the spirit of safety® are registered and protected trademarks of Pilz GmbH & Co. KG in some countries.



SD means Secure Digital

<b>1</b>	<b>Introduction</b> .....	<b>5</b>
1.1	Validity of documentation .....	5
1.2	Using the documentation .....	5
1.3	Definition of symbols .....	5
<b>2</b>	<b>Overview</b> .....	<b>7</b>
2.1	Scope .....	7
2.2	Unit features .....	7
2.3	Front view .....	8
<b>3</b>	<b>Safety</b> .....	<b>9</b>
3.1	Intended use .....	9
3.2	System requirements .....	10
3.3	Safety regulations .....	10
3.3.1	Safety assessment .....	10
3.3.2	Use of qualified personnel .....	11
3.3.3	Warranty and liability .....	11
3.3.4	Disposal .....	11
3.3.5	For your safety .....	11
<b>4</b>	<b>Function description</b> .....	<b>12</b>
4.1	Integrated protection mechanisms .....	12
4.2	Operation .....	12
4.3	Block diagram .....	12
4.4	Incremental encoders .....	13
4.4.1	Requirements of the incremental encoders .....	13
4.4.2	Adapter for incremental encoders .....	13
<b>5</b>	<b>Installation</b> .....	<b>14</b>
5.1	General installation guidelines .....	14
5.2	Dimensions .....	14
5.3	Connecting the base unit and expansion modules .....	15
<b>6</b>	<b>Commissioning</b> .....	<b>16</b>
6.1	General wiring guidelines .....	16
6.2	Pin assignment of RJ45 socket .....	16
6.3	Connecting the incremental encoder .....	17
6.3.1	Connect the signals from the incremental encoder to the speed monitor .....	17
6.3.2	Connect the incremental encoder to the speed monitor via an adapter .....	18
<b>7</b>	<b>Operation</b> .....	<b>20</b>
7.1	LED indicators .....	20
<b>8</b>	<b>Technical details</b> .....	<b>21</b>
8.1	Safety characteristic data .....	23
<b>9</b>	<b>Order reference</b> .....	<b>24</b>
9.1	Product .....	24

9.2	Accessories .....	24
<b>10</b>	<b>Application examples .....</b>	<b>25</b>
10.1	Example without position control .....	25
10.2	Example with position control .....	25

# 1 Introduction

## 1.1 Validity of documentation

This documentation is valid for the product PNOZ ms4p. It is valid until new documentation is published.

This operating manual explains the function and operation, describes the installation and provides guidelines on how to connect the product.

## 1.2 Using the documentation

This document is intended for instruction. Only install and commission the product if you have read and understood this document. The document should be retained for future reference.

## 1.3 Definition of symbols

Information that is particularly important is identified as follows:



### **DANGER!**

This warning must be heeded! It warns of a hazardous situation that poses an immediate threat of serious injury and death and indicates preventive measures that can be taken.



### **WARNING!**

This warning must be heeded! It warns of a hazardous situation that could lead to serious injury and death and indicates preventive measures that can be taken.



### **CAUTION!**

This refers to a hazard that can lead to a less serious or minor injury plus material damage, and also provides information on preventive measures that can be taken.



### **NOTICE**

This describes a situation in which the product or devices could be damaged and also provides information on preventive measures that can be taken. It also highlights areas within the text that are of particular importance.



**INFORMATION**

This gives advice on applications and provides information on special features.

## 2 Overview

### 2.1 Scope

- ▶ Expansion module PNOZ ms4p
- ▶ Jumper

### 2.2 Unit features

Application of the product PNOZ ms4p:

Speed monitor for connection to a base unit from the configurable control system PNOZmulti

The product has the following features:

- ▶ Monitoring of 1 axis
- ▶ Connection: 1 incremental encoder
- ▶ Measured variables:
  - Standstill
  - Speed (16 values can be set)
  - Direction of rotation
- ▶ Axis types, start mode can be selected in the PNOZmulti Configurator
- ▶ Status indicators for
  - Supply voltage
  - Incremental encoder
  - Axis status, standstill and excess speed
  - Faults on the system
- ▶ Incremental encoder connection technology:  
RJ45 female connector
- ▶ Function to deactivate speed monitoring
- ▶ Galvanic isolation between the connections X1 and X12
- ▶ Max. 4 speed monitors can be connected to the base unit

## 2.3 Front view

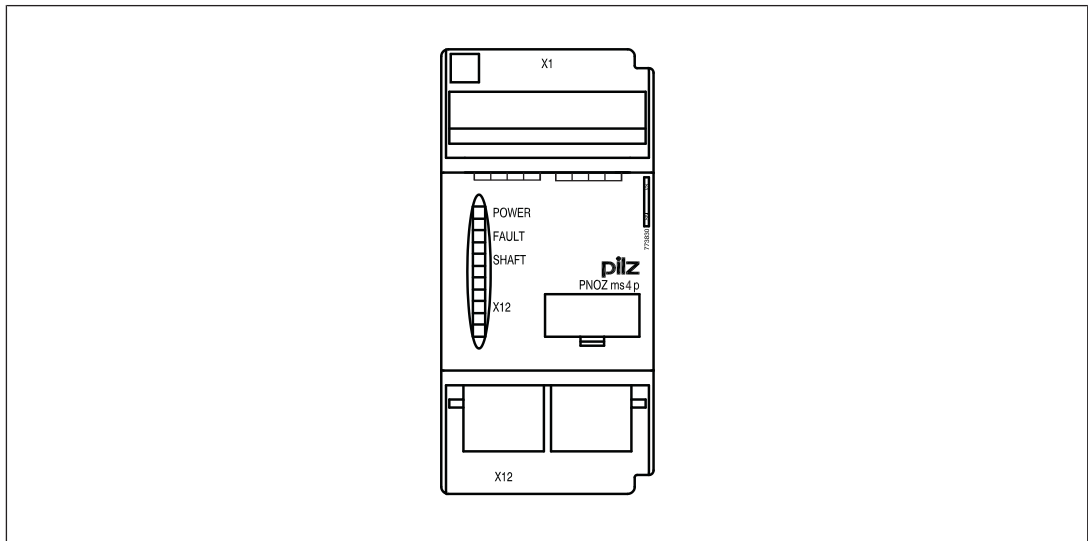

Fig.: Front view of PNOZ ms4p

**Key:**

- ▶ X12:
  - Female connector for connecting an incremental encoder
- ▶ LEDs:
  - POWER
  - FAULT
  - SHAFT
  - X12



## 3 Safety

### 3.1 Intended use

The expansion module monitors standstill, speed and direction of rotation in accordance with EN ISO 13849-1 up to PL e and EN IEC 62061 up to SIL CL 3.

The expansion module may only be connected to a base unit from the PNOZmulti system (please refer to the document "PNOZmulti System Expansion" for details of the base units that can be connected).

The configurable small control systems PNOZmulti are used for the safety-related interruption of safety circuits and are designed for use in:

- ▶ E-STOP equipment
- ▶ Safety circuits in accordance with VDE 0113 Part 1 and EN 60204-1



#### WARNING!

Users must take appropriate measures to detect or exclude errors (e.g. slippage or broken shearpin) which cause the frequency of the encoder signal to no longer be proportional to the monitored speed.

Appropriate measures are:

- Using the monitored encoder to also control the drive
- Mechanical solutions



#### WARNING!

Encoder errors are detected and signalled via a diagnostic bit. This does **not** bring the relevant axis to a safe condition.

To maintain safety (Category 3), the diagnostic bit (diagnostic bit 10) in the user program must be evaluated in such a way that a shutdown occurs if the axis is in operation (see examples in Chapter 9).



#### CAUTION!

If there are frequency differences between tracks A and B of the incremental encoder, the track with the higher frequency will be evaluated. Different directions of rotation will no longer be detected. The outputs *Clockwise* and *Anti-clockwise* switch to a safe condition. The safe condition is cleared again as soon as the error is remedied. Hazards that can arise through an automatic restart must be excluded within the user program.

The following is deemed improper use in particular

- ▶ Any component, technical or electrical modification to the product,
- ▶ Use of the product outside the areas described in this manual,
- ▶ Use of the product outside the technical details (see Technical details).



**NOTICE**

**EMC-compliant electrical installation**

The product is designed for use in an industrial environment. The product may cause interference if installed in other environments. If installed in other environments, measures should be taken to comply with the applicable standards and directives for the respective installation site with regard to interference.

## 3.2 System requirements

Please refer to the "Product Modifications PNOZmulti" document in the "Version overview" section for details of which versions of the base unit and PNOZmulti Configurator can be used for this product.

## 3.3 Safety regulations

### 3.3.1 Safety assessment

Before using a device it is necessary to perform a safety assessment in accordance with the Machinery Directive.

Functional safety is guaranteed for the product as a single component. However, this does not guarantee the functional safety of the overall plant/machine. In order to achieve the required safety level for the overall plant/machine, define the safety requirements for the plant/machine and then define how these must be implemented from a technical and organisational standpoint.

### 3.3.2 Use of qualified personnel

The products may only be assembled, installed, programmed, commissioned, operated, maintained and decommissioned by competent persons.

A competent person is someone who, because of their training, experience and current professional activity, has the specialist knowledge required to test, assess and operate the work equipment, devices, systems, plant and machinery in accordance with the general standards and guidelines for safety technology.

It is the company's responsibility only to employ personnel who

- ▶ Are familiar with the basic regulations concerning health and safety / accident prevention,
- ▶ Have read and understood the information provided in this description under "Safety",
- ▶ And have a good knowledge of the generic and specialist standards applicable to the specific application.

### 3.3.3 Warranty and liability

All claims to warranty and liability will be rendered invalid if

- ▶ The product was used contrary to the purpose for which it is intended,
- ▶ Damage can be attributed to not having followed the guidelines in the manual,
- ▶ Operating personnel are not suitably qualified,
- ▶ Any type of modification has been made (e.g. exchanging components on the PCB boards, soldering work etc.).

### 3.3.4 Disposal

- ▶ In safety-related applications, please comply with the mission time  $T_M$  in the safety-related characteristic data.
- ▶ When decommissioning, please comply with local regulations regarding the disposal of electronic devices (e.g. Electrical and Electronic Equipment Act).

### 3.3.5 For your safety

The unit meets all the necessary conditions for safe operation. However, you should always ensure that the following safety requirements are met:

- ▶ This operating manual only describes the basic functions of the unit. The expanded functions are described in the PNOZmulti Configurator's online help. Only use these functions once you have read and understood the documentations.
- ▶ Do not open the housing or make any unauthorised modifications.
- ▶ Please make sure you shut down the supply voltage when performing maintenance work (e.g. exchanging contactors).

## 4 Function description

### 4.1 Integrated protection mechanisms

The relay meets the following safety requirements:

- ▶ The circuit is redundant with built-in self-monitoring.
- ▶ The safety device remains effective in the case of a component failure.

### 4.2 Operation

The speed monitor can monitor an axis for standstill, speed and direction of rotation. The speed monitor signals the status of the monitored values to the base unit. Depending on the implemented safety circuit, the values may be transferred from the base unit to a relay output on the safety system, for example. Incremental encoders may be used to record the values.

The configuration of the speed monitor is described in detail in the PNOZmulti Configurator's online help.

### 4.3 Block diagram

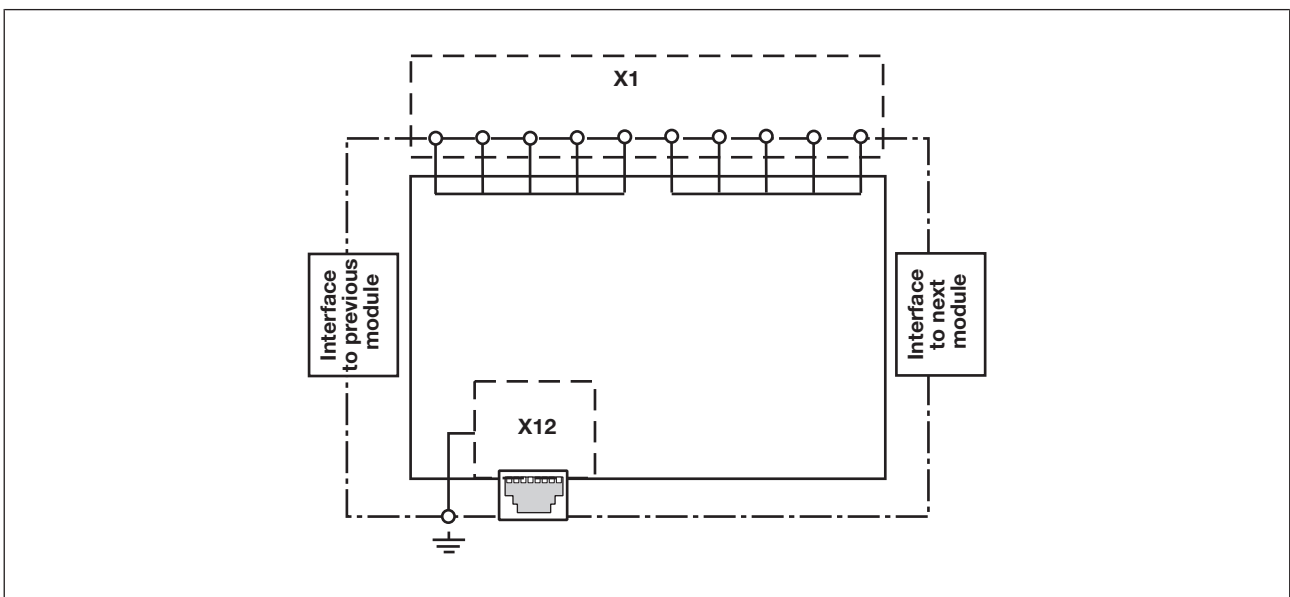

## **4.4 Incremental encoders**

### **4.4.1 Requirements of the incremental encoders**

- ▶ Only incremental encoders with a differential output of the following type are permitted
  - Sin/Cos
  - TTL (RS 422)
  - HTL (24 V)
- ▶ Please note the values stated in the technical details

### **4.4.2 Adapter for incremental encoders**

The adapter records the data between the encoder and drive and makes it available to the PNOZ ms4p via the RJ45 socket.

Pilz supplies complete adapters as well as ready-made cable with RJ45 connector, which can be used when making your own adapter. The range of products in this area is constantly being expanded. Please contact us about the range of adapters that is currently available.

## 5 Installation

### 5.1 General installation guidelines

- ▶ The control system should be installed in a control cabinet with a protection type of at least IP54. Fit the control system to a horizontal mounting rail. The venting slots must face upward and downward. Other mounting positions could destroy the control system.
- ▶ Use the locking elements on the rear of the unit to attach it to a mounting rail. Connect the control system to the mounting rail in an upright position, so that the earthing springs on the control system are pressed on to the mounting rail.
- ▶ The ambient temperature of the devices in the control cabinet must not exceed the figure stated in the technical details. Air conditioning may otherwise be required.
- ▶ To comply with EMC requirements, the mounting rail must have a low impedance connection to the control cabinet housing.



#### NOTICE

Damage due to electrostatic discharge!

Electrostatic discharge can damage components. Ensure against discharge before touching the product, e.g. by touching an earthed, conductive surface or by wearing an earthed armband.

### 5.2 Dimensions

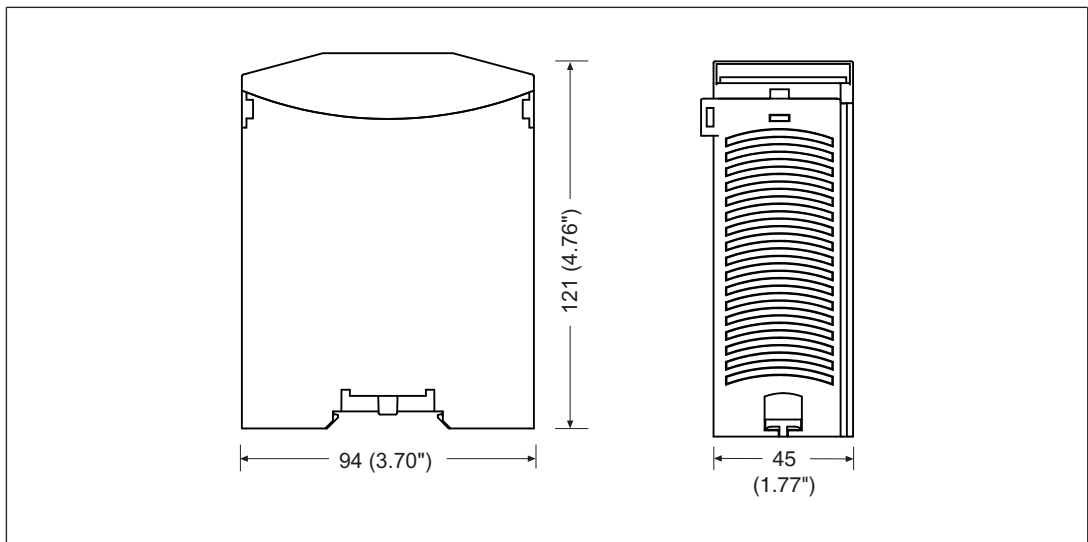

### 5.3 Connecting the base unit and expansion modules

Connect the base unit and the expansion modules as described in the operating manuals for the base modules.

- ▶ The terminator must be fitted to the last expansion module
- ▶ Install the expansion module in the position configured in the PNOZmulti Configurator.

The position of the expansion modules is defined in the PNOZmulti Configurator. The expansion modules are connected to the left or right of the base unit, depending on the type.

Please refer to the document "PNOZmulti System Expansion" for details of the number of modules that can be connected to the base unit and the module types.

## 6 Commissioning

### 6.1 General wiring guidelines

The wiring is defined in the circuit diagram of the PNOZmulti Configurator.

Details of the input type, axis type and reset mode, plus the values for standstill, speed monitoring and direction of rotation are also defined in the PNOZmulti Configurator.

Please note:

- ▶ Information given in the Technical details must be followed.
- ▶ Use copper wiring with a temperature stability of 75 °C.



#### CAUTION!

The configurable switch-off delay when overspeed is reached increases the reaction time of the system comprising base unit and speed monitor by the stated value (see technical details). This must not delay the transfer to a safe condition by more than the permitted time. The configuration of the switch-off delay must be considered in the risk assessment as regards hazards, reaction time and safety distance.

### 6.2 Pin assignment of RJ45 socket

RJ45 socket 8-pin	PIN	Track
	1	5 V
	2	0 V
	3	T
	4	A
	5	/A
	6	/Z
	7	B
	8	/B



## 6.3 Connecting the incremental encoder

Proceed as follows when connecting the incremental encoder:

- ▶ The incremental encoder may be connected via an adapter (e.g. ) or directly to the speed monitor.
- ▶ The incremental encoder on connector X12 monitors the axis
- ▶ Use only shielded cables for all connections
- ▶ 0 V from the incremental encoder and speed monitor should always be connected.
- ▶ Position the terminating resistors of the signal lines as close as possible to the speed monitor input.

### 6.3.1 Connect the signals from the incremental encoder to the speed monitor

Encoder types: 1 Vss, 5 V-TTL

- ▶ Apply 5 V DC to incremental encoder only
- ▶ Do not terminate incremental encoder with  $Z_0 = 120 \text{ Ohm}$

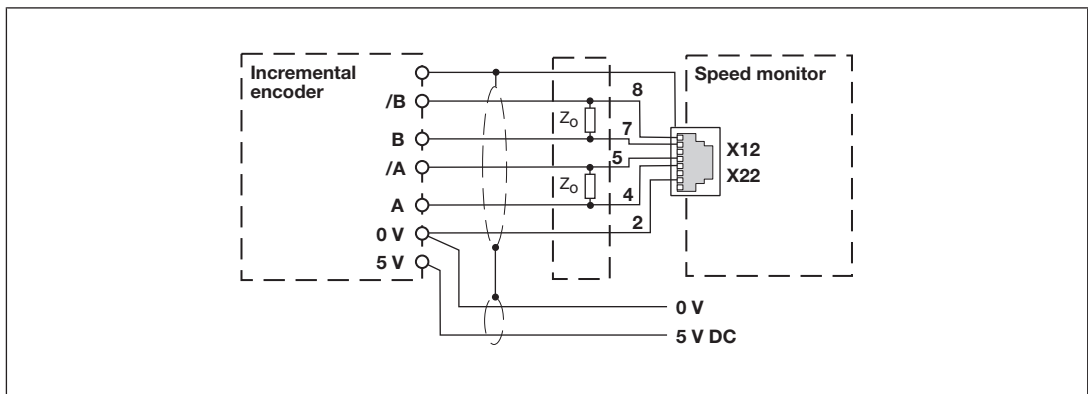

Fig.: Connection to incremental encoder type 1 Vss, 5 V-TTL

Encoder types: 24 V-HTL

- ▶ Apply 24 V DC supply voltage to incremental encoder only
- ▶ Do not terminate incremental encoder with  $Z_0 = 120 \text{ Ohm}$

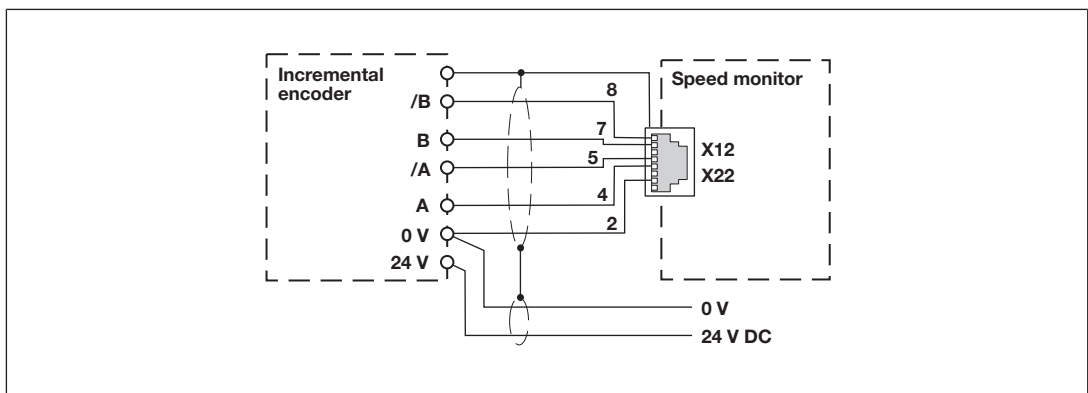

Fig.: Connection to incremental encoder type 24 V-HTL

### 6.3.2 Connect the incremental encoder to the speed monitor via an adapter

- ▶ The adapter is connected between the incremental encoder and the drive. The output on the adapter is connected to the RJ-45 female connector on the speed monitor.
- ▶ The adapter can also be used without connecting to a drive. The signal lines can then be terminated directly at the adapter with  $Z_o = 120 \text{ Ohm}$ .
- ▶ If the signal lines in the drive are already terminated with  $Z_o = 120 \text{ Ohm}$ , the incremental encoder may no longer be terminated.
- ▶ The signals relevant for the speed monitor are utilised in parallel by the adapter. The information stated under "Connect incremental encoder signals to the speed monitor" and in the adapter operating manual must be observed when connecting the supply voltage.
- ▶ Supply only incremental encoder with 5 V DC. 24 V-HTL signals may not be terminated.



#### CAUTION!

Communication errors may occur if the adapter cable is too long or there are any external sources of interference. The length of the adapter cable should be <5 m. Lay the adapter cable separately from any potential sources of interference, such as drive cables leading to the motor, for example.

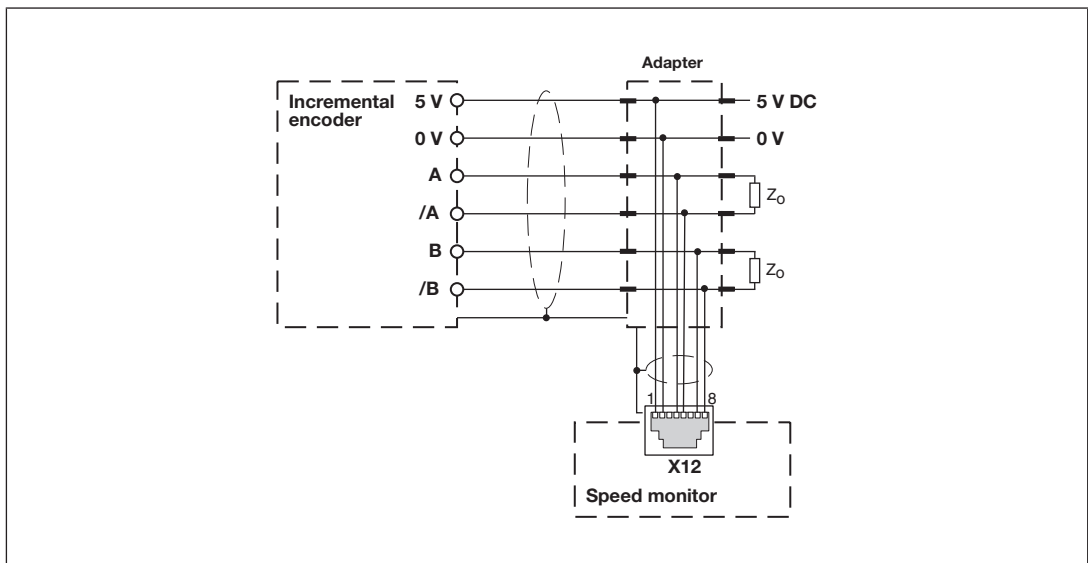

Fig.: Connection via adapter

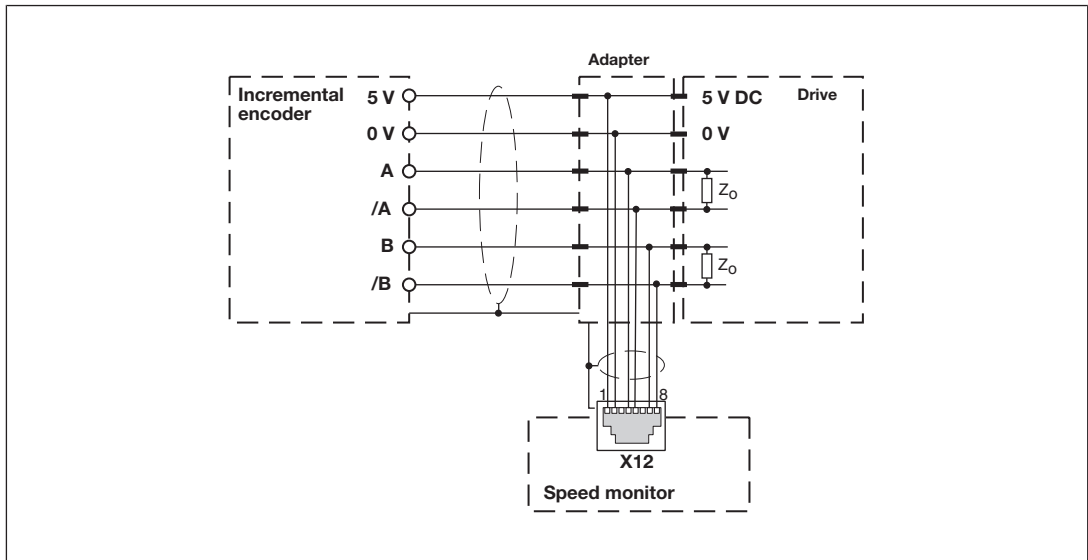

Fig.: Connection via adapter and drive





## 7 Operation









When the supply voltage is switched on, the PNOZmulti copies the configuration from the chip card.

The PNOZmulti safety system is ready for operation when the "POWER" and "RUN" LEDs on the base unit and the "READY" LED on the PNOZ ms4p are lit continuously.

### 7.1 LED indicators

#### Legend

-  LED on
-  LED flashes
-  LED flashes briefly
-  LED off

LED	LED status	Meaning
POWER		Supply voltage is present.
FAULT		External fault leading to a safe condition; the fault is at the incremental encoder inputs whose LEDs are flashing, e.g. short across the contacts
		Internal fault leading to safe condition
SHAFT		Encoder or wiring fault
		Axis is in the normal range (no standstill, no overspeed)
		Axis is signalling standstill
		Axis is signalling overspeed
X12		Incremental encoder on terminal X12 is connected correctly

## 8 Technical details

<b>General</b>	
Certifications	<b>BG, CCC, CE, EAC (Eurasian), TÜV, cULus Listed</b>
<b>Electrical data</b>	
Supply voltage	
for	<b>Module supply</b>
Voltage	<b>5 V</b>
Kind	<b>DC</b>
Voltage tolerance	<b>-2 %/+2 %</b>
Power consumption	<b>1 W</b>
Status indicator	<b>LED</b>
<b>Incremental encoder input</b>	
Number of inputs	<b>1</b>
Connection type	<b>RJ45 female connector, 8-pin</b>
Input signal level	<b>0,5 - 30 V<sub>ss</sub></b>
Phase position for the differential signals A, /A and B, /B	<b>90° ±30°</b>
Overload protection	<b>-30 - 30 V</b>
Input resistance	<b>10 kOhm</b>
Input's frequency range	<b>0 - 500 kHz</b>
Configurable monitoring frequency	
Without hysteresis	<b>0,1 Hz - 500 kHz</b>
With hysteresis	<b>0.2 Hz - 500 kHz</b>
<b>Times</b>	
Configurable switch-off delay	<b>0 - 2.500 ms</b>
Supply interruption before de-energisation	<b>20 ms</b>
Reaction time	
f > 100 Hz: Configurable switch-off delay + switch-off delay of base unit	<b>10 ms</b>
f < 100 Hz: Configurable switch-off delay + switch-off delay of base unit	<b>10 ms + 1/f</b>
<b>Environmental data</b>	
Ambient temperature	
In accordance with the standard	<b>EN 60068-2-14</b>
Temperature range	<b>0 - 60 °C</b>
Storage temperature	
In accordance with the standard	<b>EN 60068-2-1/-2</b>
Temperature range	<b>-25 - 70 °C</b>
Climatic suitability	
In accordance with the standard	<b>EN 60068-2-30, EN 60068-2-78</b>
Humidity	<b>93 % r. h. at 40 °C</b>
Condensation during operation	<b>Not permitted</b>
EMC	<b>EN 61131-2</b>

**Environmental data**

Vibration	
In accordance with the standard	<b>EN 60068-2-6</b>
Frequency	<b>10 - 150 Hz</b>
Acceleration	<b>1g</b>
Shock stress	
In accordance with the standard	<b>EN 60068-2-27</b>
Acceleration	<b>15g</b>
Duration	<b>11 ms</b>
Max. operating height above sea level	<b>2000 m</b>
Airgap creepage	
In accordance with the standard	<b>EN 61131-2</b>
Overvoltage category	<b>III</b>
Pollution degree	<b>2</b>
Rated insulation voltage	<b>30 V</b>
Protection type	
In accordance with the standard	<b>EN 60529</b>
Mounting area (e.g. control cabinet)	<b>IP54</b>
Housing	<b>IP20</b>
Terminals	<b>IP20</b>

**Mechanical data**

Mounting position	<b>horizontally on mounting rail</b>
DIN rail	
Top hat rail	<b>35 x 7,5 EN 50022</b>
Recess width	<b>27 mm</b>
Material	
Bottom	<b>PPO UL 94 V0</b>
Front	<b>ABS UL 94 V0</b>
Connection type	<b>Spring-loaded terminal, screw terminal</b>
Conductor cross section with screw terminals	
1 core flexible	<b>0,25 - 1,5 mm<sup>2</sup>, 24 - 16 AWG</b>
2 core with the same cross section, flexible without crimp connectors or with TWIN crimp connectors	<b>0,25 - 0,75 mm<sup>2</sup>, 24 - 20 AWG</b>
Torque setting with screw terminals	<b>0,25 Nm</b>
Stripping length with screw terminals	<b>7 mm</b>
Conductor cross section with spring-loaded terminals	
1 core flexible without crimp connector	<b>0,25 - 1,5 mm<sup>2</sup>, 24 - 16 AWG</b>
1 core flexible with crimp connector	<b>0,25 - 0,75 mm<sup>2</sup>, 24 - 20 AWG</b>
Spring-loaded terminals: Terminal points per connection	<b>1</b>
Stripping length with spring-loaded terminals	<b>9 mm</b>
Dimensions	
Height	<b>94 mm</b>
Width	<b>45 mm</b>
Depth	<b>121 mm</b>

**Mechanical data**

Weight **203 g**

Where standards are undated, the 2020-07 latest editions shall apply.

**8.1 Safety characteristic data**

Operating mode	EN ISO 13849-1: 2015 PL	EN ISO 13849-1: 2015 Category	EN IEC 62061 SIL CL	EN IEC 62061 PFH <sub>D</sub> [1/h]	IEC 61511 SIL	IEC 61511 PFD	EN ISO 13849-1: 2015 T <sub>M</sub> [year]
Incremental encoder	<b>PL e</b>	<b>Cat. 3</b>	<b>SIL CL 3</b>	<b>6,36E-09</b>	<b>SIL 3</b>	<b>8,45E-05</b>	<b>20</b>

All the units used within a safety function must be considered when calculating the safety characteristic data.



**INFORMATION**

A safety function's SIL/PL values are **not** identical to the SIL/PL values of the units that are used and may be different. We recommend that you use the PAScal software tool to calculate the safety function's SIL/PL values.

## 9 Order reference

### 9.1 Product

Product type	Features	Order No.
PNOZ ms4p	Expansion module, speed monitor	773 830

### 9.2 Accessories

#### Connection terminals

Product type	Features	Order no.
Set spring terminals	1 set of spring-loaded terminals	783 800
Set screw terminals	1 set of screw terminals	793 800

#### Terminator, jumper

Product type	Features	Order no.
PNOZmulti bus terminator	Terminator	779 110
KOP-XE	Jumper	774 639



## 10 Application examples

### 10.1 Example without position control

#### Evaluation of bit: "Unfeasible or single-channel signal from the incremental encoder", without position control

Diagnostic bit 10: "Unfeasible or single-channel signal from the incremental encoder" must be evaluated in the user program during operation in such a way that a set bit leads to a safety-related error reaction (shutdown).

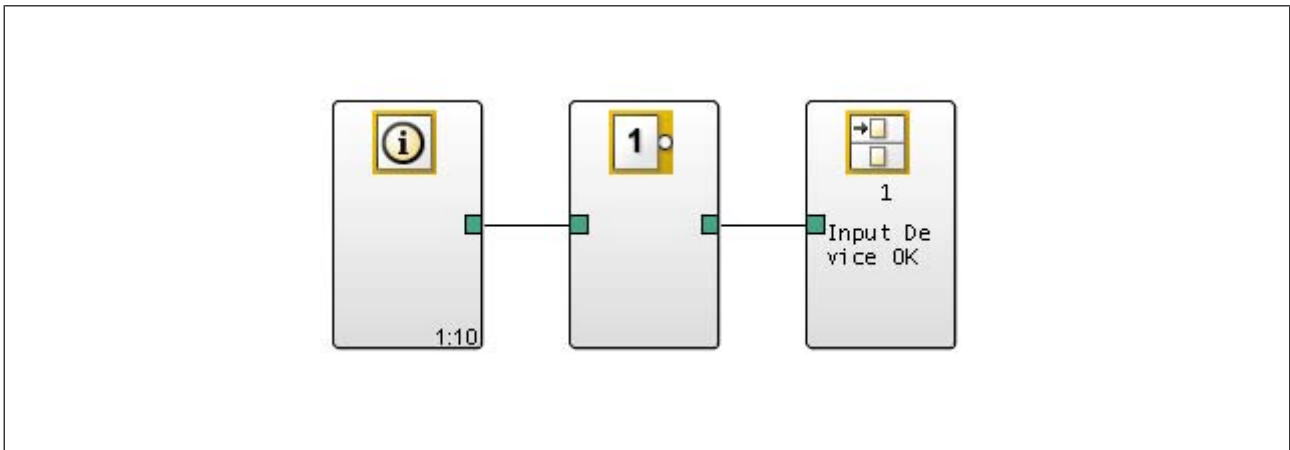

The connection point "Input Device OK" must be incorporated into the application and evaluated in such a way that a shutdown occurs if the connection point "Input Device OK" = 0.

### 10.2 Example with position control

#### Evaluation of bit: "Unfeasible or single-channel signal from the incremental encoder", with position control

Diagnostic bit 10: "Unfeasible or single-channel signal from the incremental encoder" may be set during position control as a result of jitter on the encoder.

The set bit can be tolerated, i.e. evaluated in the user program in such a way that a shutdown will not occur if the following conditions are met:

- ▶ An additional position control signal must be provided from an external control system (e.g. PLC) and
- ▶ The signal must have the following status conditions:
  - Position control: Signal status = 1
  - Operation: Signal status = 0

During operation, diagnostic bit 10 must be evaluated in the user program in such a way that a set bit leads to a safety-related error reaction (shutdown).



The time element with configured switch-off delay operates as a start-up suppressor, as the bit: "Unfeasible or single-channel signal from the incremental encoder" may still be present for 2 s after leaving standstill.

The connection point "Input Device OK" must be incorporated into the application and evaluated in such a way that a shutdown occurs if the connection point "Input Device OK" = 0.

