



## PNOZ msi b4 Box

**PILZ**  
THE SPIRIT OF SAFETY

► Accessories PNOZmulti

This document is the original document.

Where unavoidable, for reasons of readability, the masculine form has been selected when formulating this document. We do assure you that all persons are regarded without discrimination and on an equal basis.

All rights to this documentation are reserved by Pilz GmbH & Co. KG. Copies may be made for the user's internal purposes. Suggestions and comments for improving this documentation will be gratefully received.

Pilz®, PIT®, PMI®, PNOZ®, Primo®, PSEN®, PSS®, PVIS®, SafetyBUS p®, SafetyEYE®, SafetyNET p®, the spirit of safety® are registered and protected trademarks of Pilz GmbH & Co. KG in some countries.



SD means Secure Digital

## Introduction

### Validity of documentation

This documentation is valid for the product PNOZ msi b4 Box from Version 2.0.

This operating manual explains the function and operation, describes the installation and provides guidelines on how to connect the product.

### Description

The shielded junction box PNOZ msi b4 Box is used to connect

- ▶ An incremental encoder with an additional feed for the incremental encoder supply  
or
- ▶ An incremental encoder in conjunction with a proximity switch with/without pull resistor (dual encoder evaluation) with an additional supply for the proximity switch  
or
- ▶ 2 proximity switches with/without pull resistor with an additional supply for the proximity switches

to the Pilz speed monitors.

### Front view

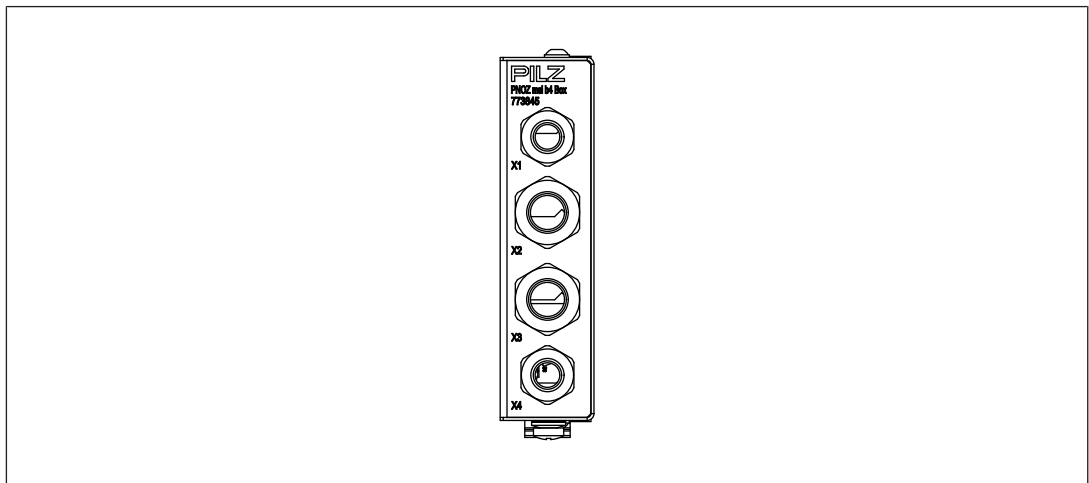

### Installation

- ▶ The junction box should be installed in a control cabinet with a protection type of at least IP54.
- ▶ Fit the junction box to a horizontal mounting rail.
- ▶ Use the locking slide on the rear of the junction box to attach it to a mounting rail.
- ▶ In environments exposed to heavy vibration, the unit should be secured using a fixing element (e.g. retaining bracket or end angle).
- ▶ Open the locking slide before lifting the unit from the mounting rail.

### Mounting distances

For the wiring to be EMC-compliant, the junction box must maintain a distance of at least 5.5 mm from other conductive parts (e.g. adjacent housing parts) (see diagram).

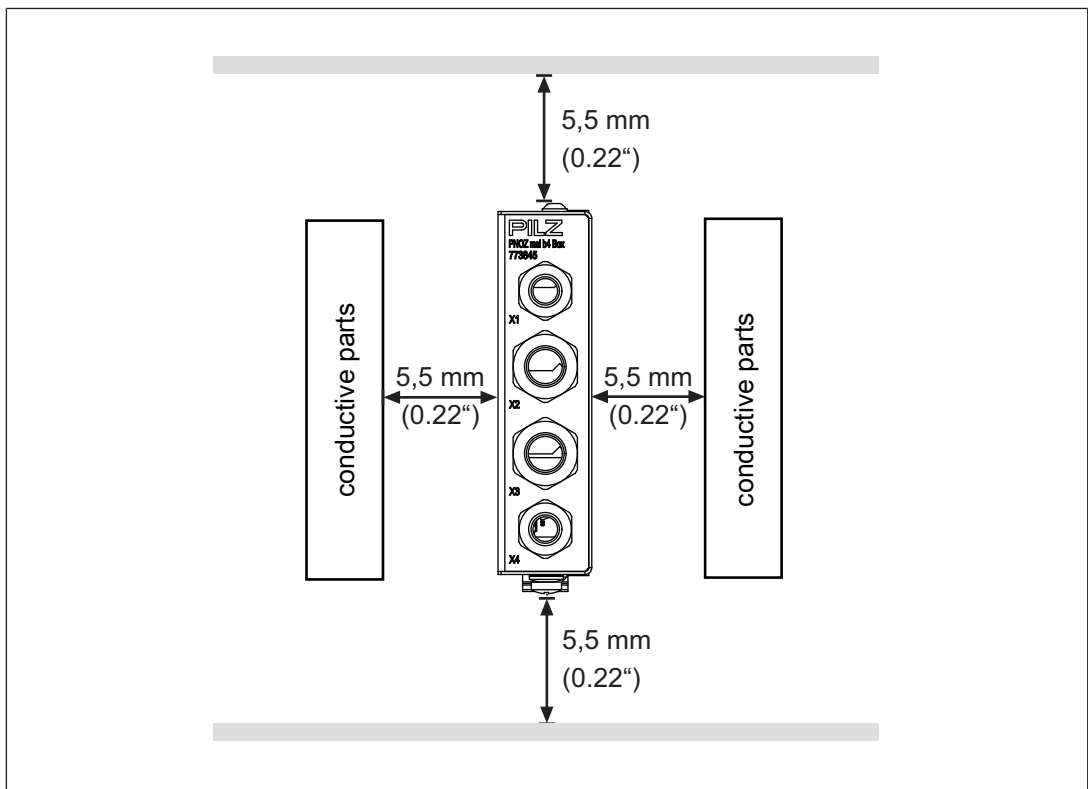

### Dimensions in mm

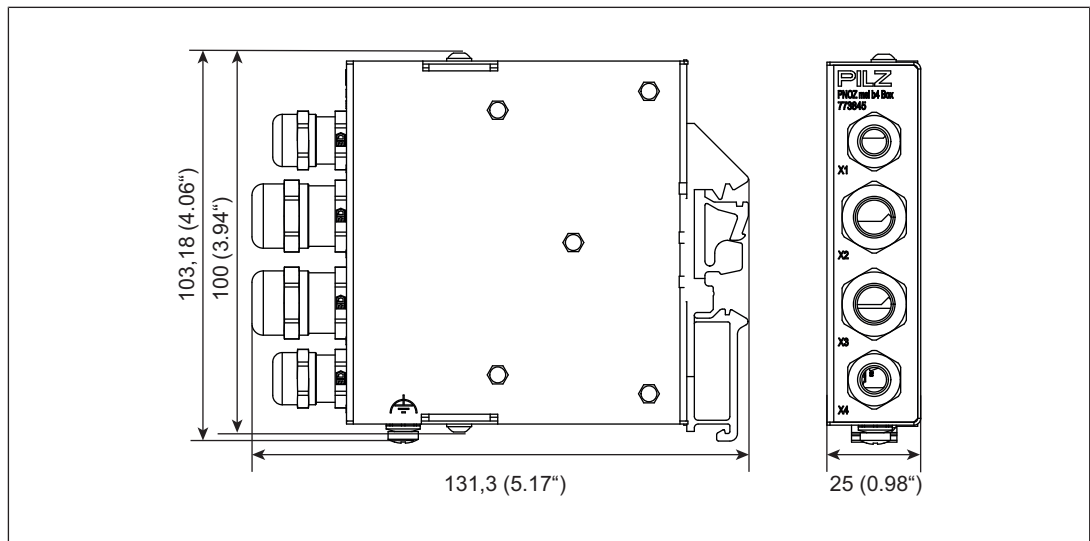

### Connection



#### INFORMATION

The connected supply voltages and the sensors have to be supplied from power supplies that comply with the regulations for extra low voltages with safe electrical isolation.

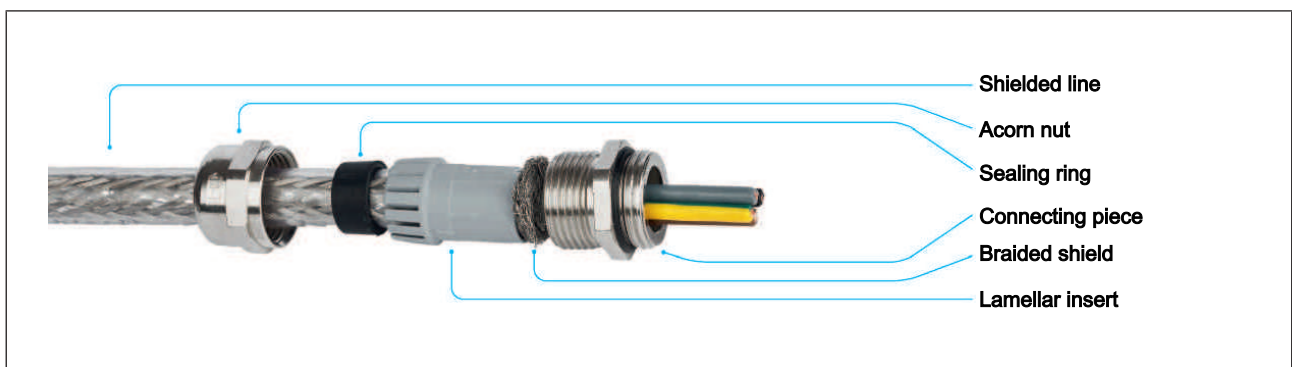

1. Remove the external insulation of the line and expose the braided shield, depending on the conductor cross section, to approx. 10-15 mm.
2. Push acorn nut and lamellar insert with gasket onto the line.
3. Bend braided shield to the outside at a right angle (90°).
4. Crimp over braided shield towards the external cable insulation, i.e. crimp it over again by 180°.
5. Insert connecting piece up to the braided shield and turn it shortly back and forth round the line axis.
6. Push lamellar insert with gasket into the connecting piece and snap in the anti-twist protection.
7. Screw the acorn nut firmly.

**Internal view**

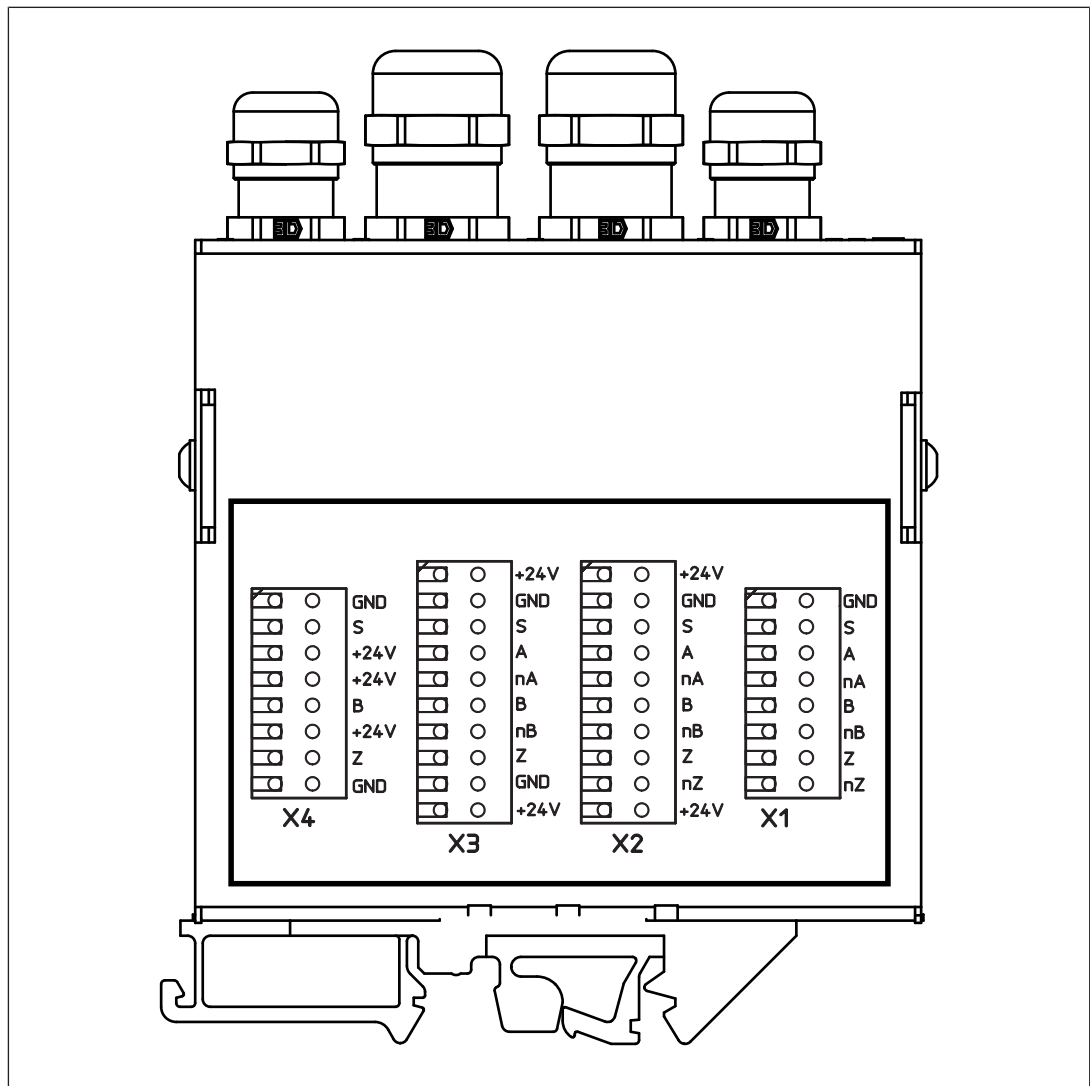

The cable ducts and the corresponding terminals are each labelled identically (X1 ... X4).

- ▶ Cable ducts at X1 and X4:  
Size M12x1.5 with terminals for cable diameters from 3 to 6.5 mm, tighten with spanner size SW 14 mm and torque setting 8 Nm.
- ▶ Cable ducts at X2 and X3:  
Size M16x1.5 with terminals for cable diameters from 5 to 9 mm, tighten with spanner size SW 17 mm and torque setting 8 Nm.

The identically named signals (GND, S, 24 V...) are connected to each other between the terminals X1 ... X4 internally.



**INFORMATION**

When using crimp connectors the connection wires can be inserted into the connectors of the spring-loaded terminals. Pressing the operating pushbutton is necessary only to undo the connection.

Internal wiring diagram

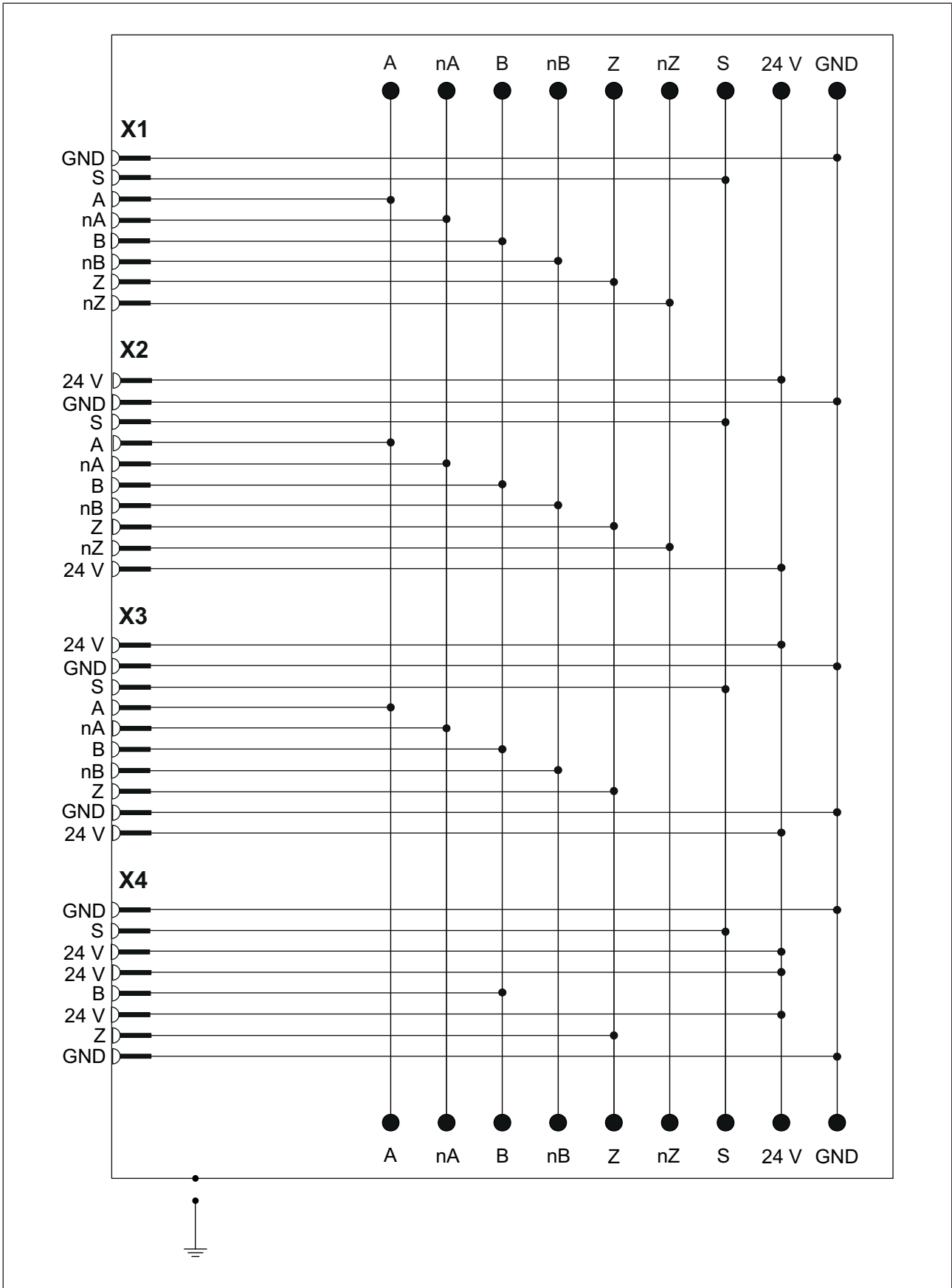

**Connection examples**

**Example 1**

Encoder directly to a speed monitor from Pilz, supply voltage for encoder via bridge at terminals S - 24 V of connector X4,

Option: Wiring of encoder outputs (connector X3)

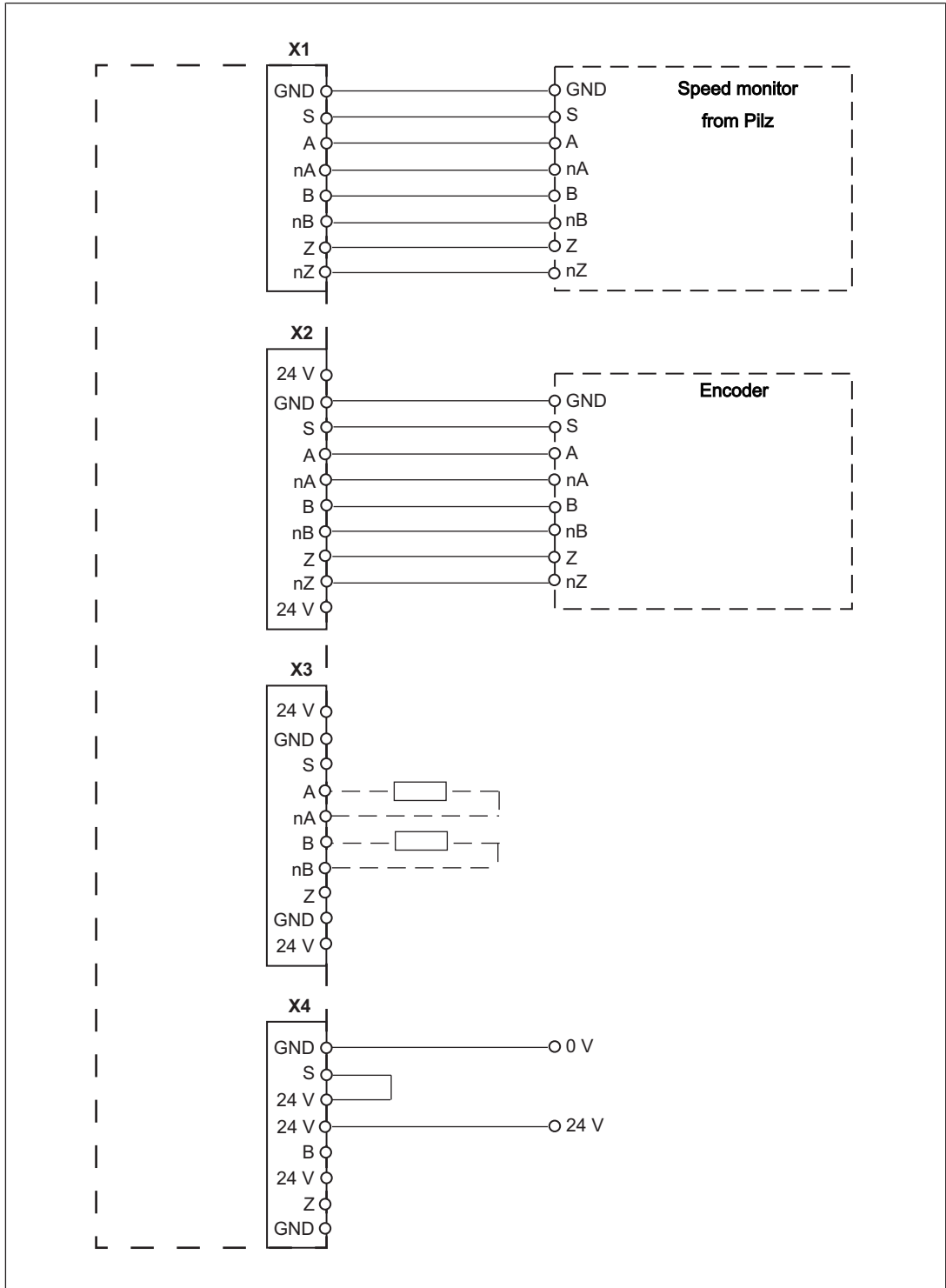



**Example 2**

Encoder and proximity switch (sensor type in PNOZmulti Config: HTL differential + Z frequency InI pnp) for monitoring for broken shearpins, do not connect Z and nZ of the encoder, supply voltage for encoder via bridge at terminals S - 24 V of connector X4, Option: Wiring of the outputs of the encoder (connector X3) and pull-down resistor for Z (connector X4)

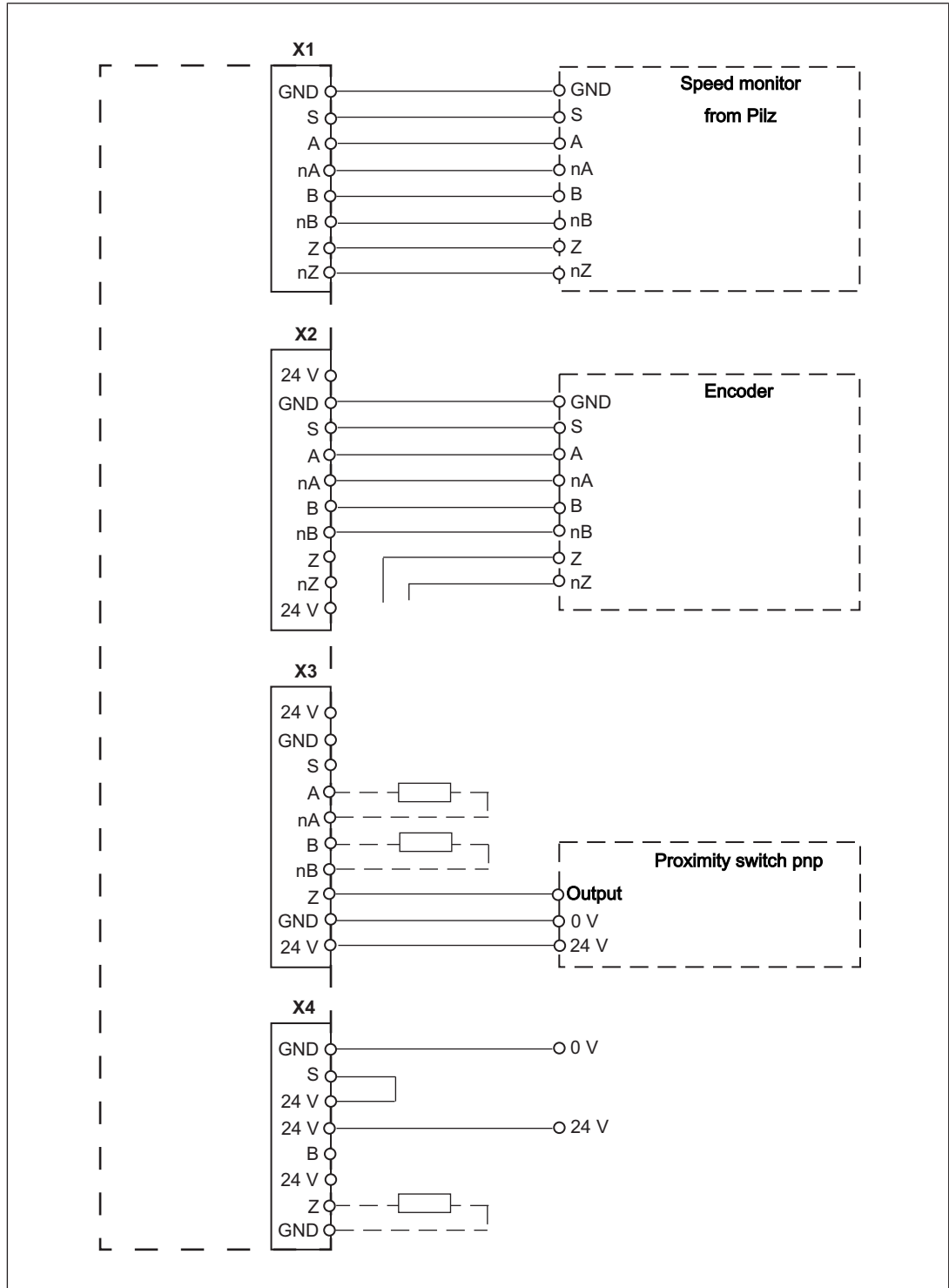

**Example 3**

2 proximity switches, supply voltage for proximity switches via connector X4

Option: Pull-down/pull-up resistance for A (connector X2), pull-down/pull-up resistance for B (connector X4), monitoring track S (connector X4)

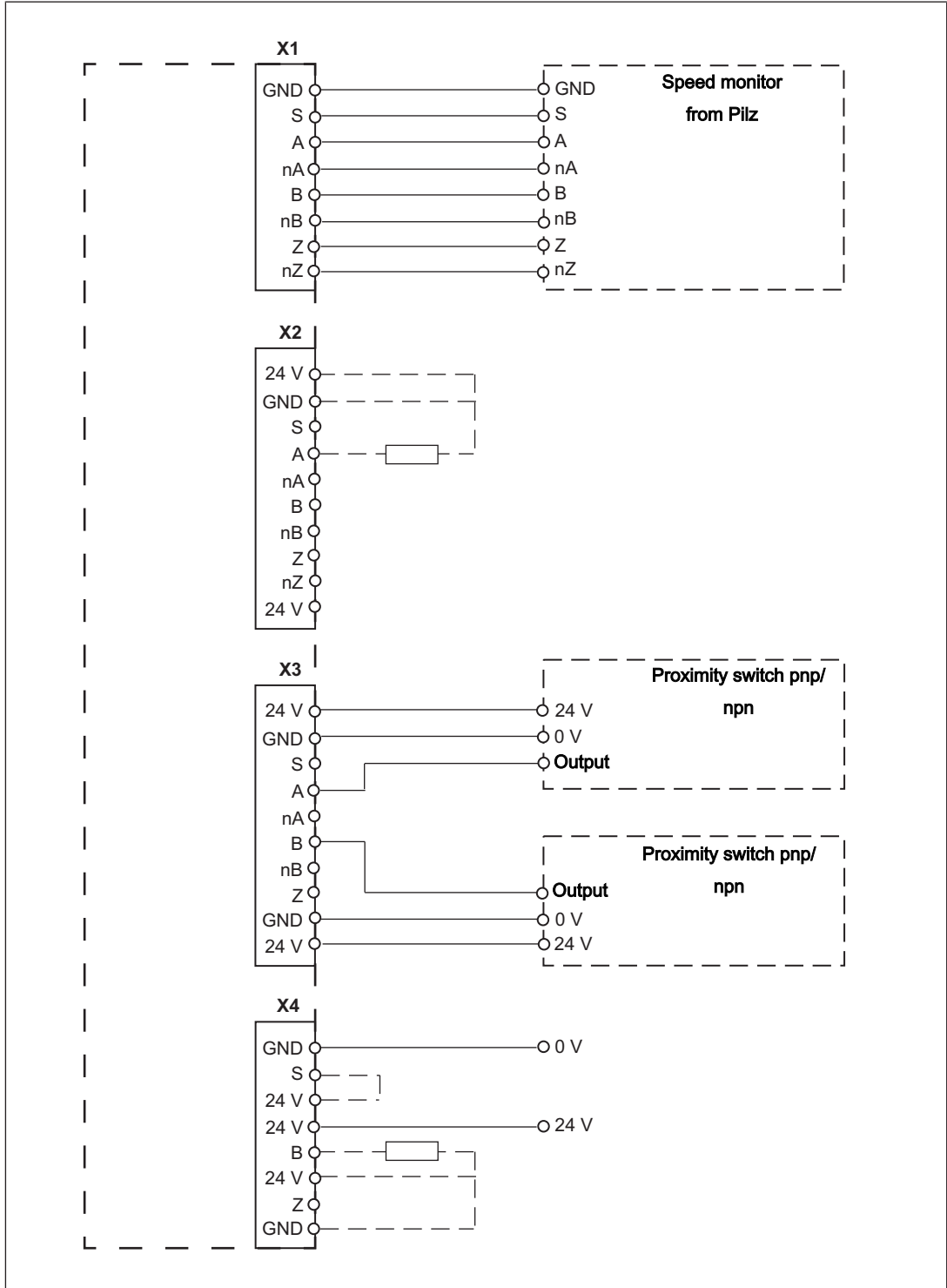

**Example 4**

Tap the signals of the encoder via a Pilz adapter (e.g. MM A MINI-IO CAB99) and the proximity switch (sensor type in PNOZmulti Config: HTL differential + Z frequency InI pnp), supply voltage for proximity switch (connector X4)  
 Option: Pull-down resistor for Z (connector X4)

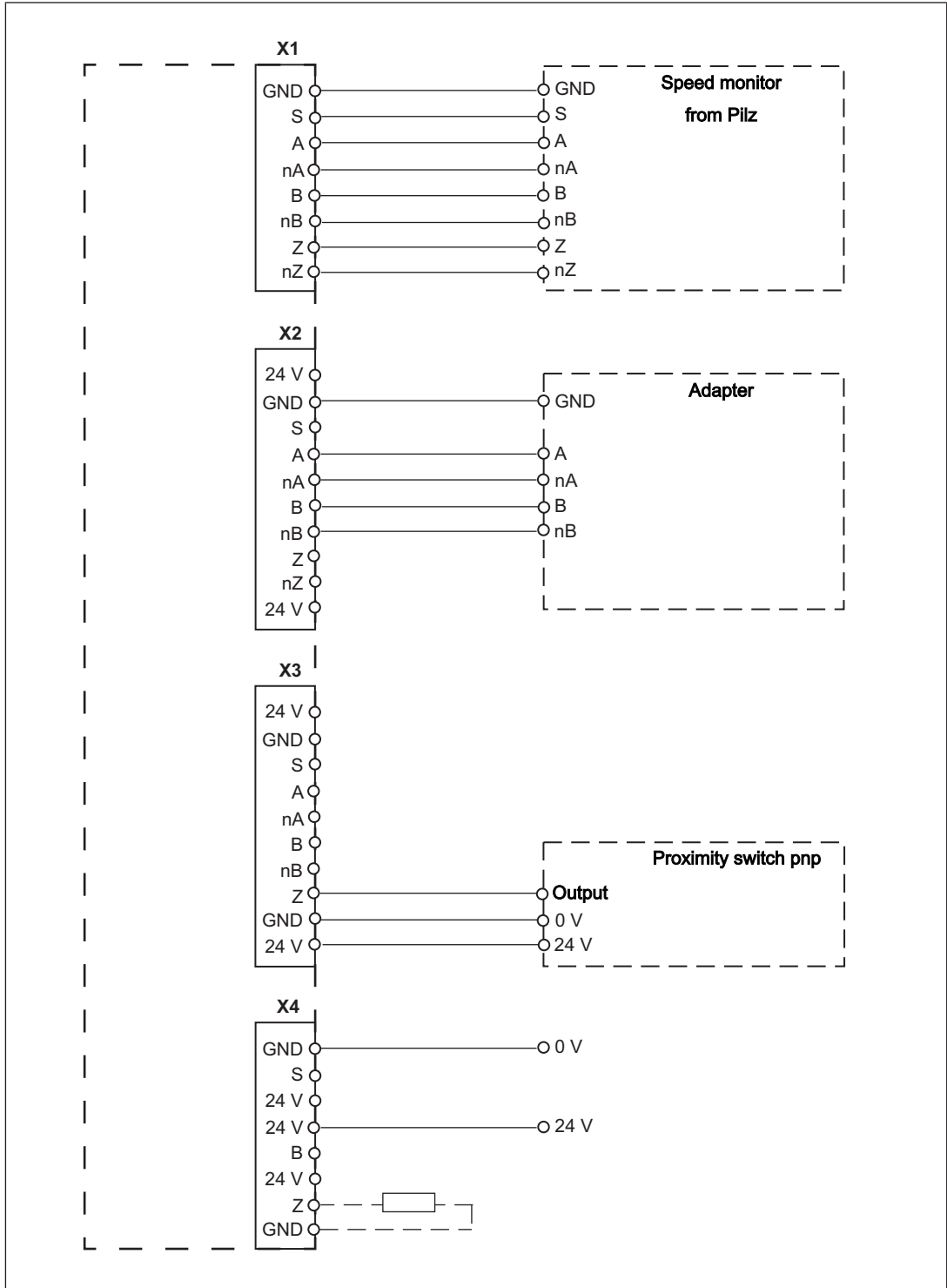

**Example 5**

Encoder and proximity switch (sensor type in PNOZmulti Config: HTL differential + Z frequency InI pnp) for monitoring for broken shearpins, do not connect and/or separate Z and nZ of the encoder, separate supply voltage for proximity switch (via connector X3) and encoder,

Option: Pull-down resistor for Z (connector X4)

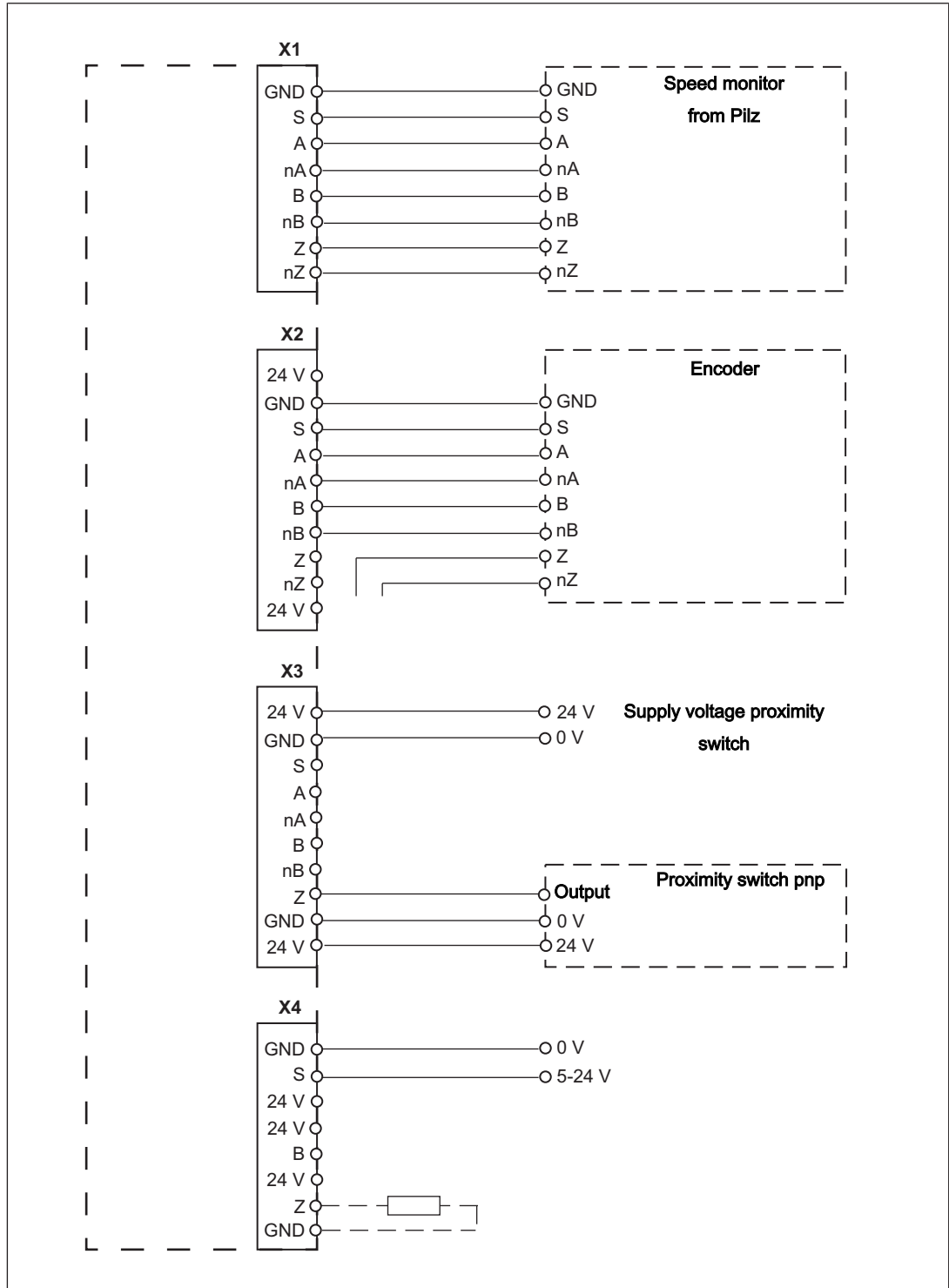

**Example 6**

as in example 4, PNOZ msi b4 box replaces adapter, proximity switch with own supply voltage,

Option: Pull-down resistor for Z (connector X3)

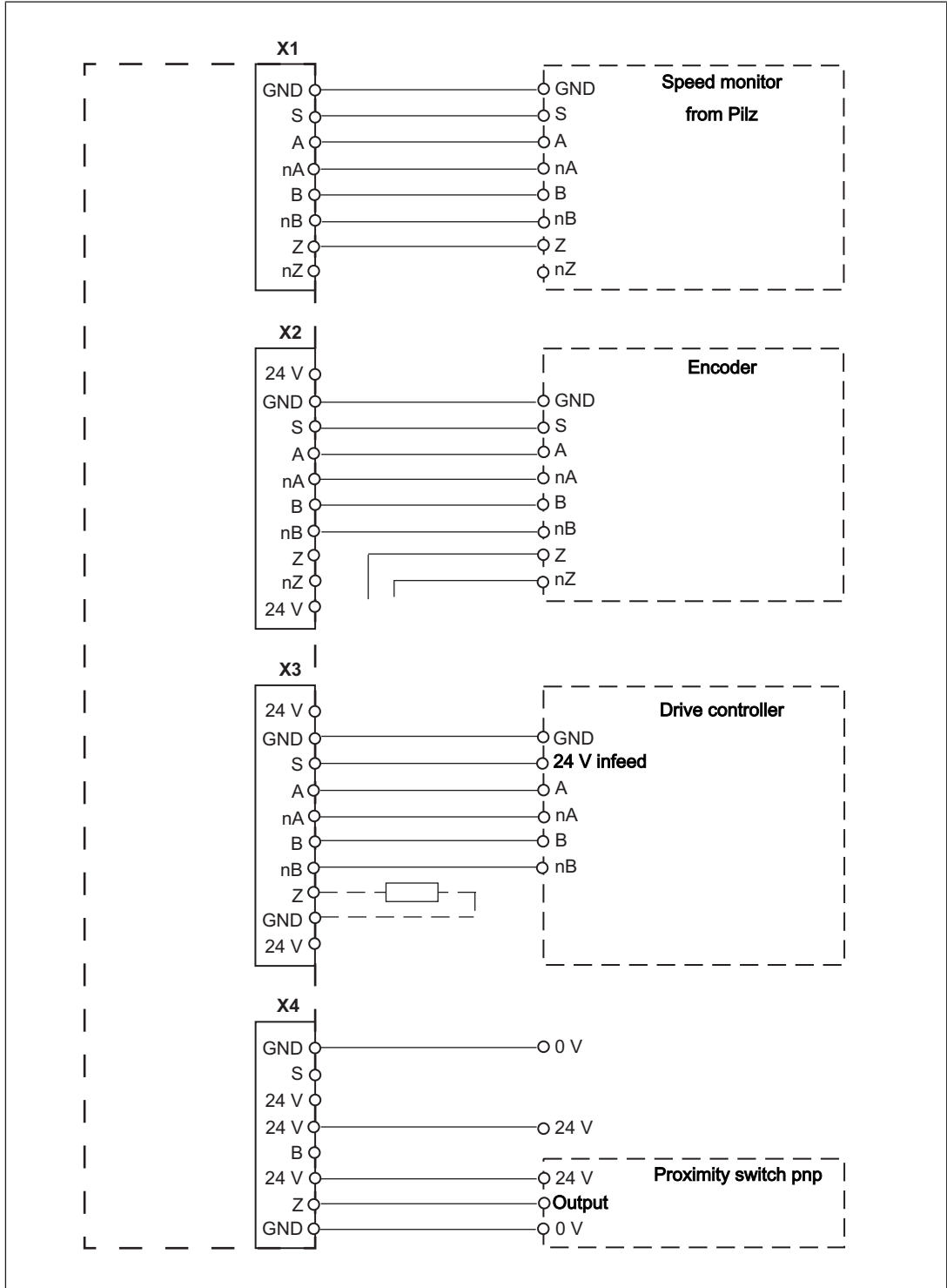



**INFORMATION**

Further information on the connection is available in the operating instructions for the respective speed monitor.



**INFORMATION**

The GND signal is not connected to earth.

### EMC-compliant wiring



#### INFORMATION

With EMC-compliant wiring inside the connection box, make sure that the cores for signals A, nA or B, nB or Z, nZ

- Are no longer than necessary
- Remain twisted in pair as far as the terminal.

The individual core strands must not touch the housing wall.

EMC-compliant wiring for connecting an encoder and a drive:

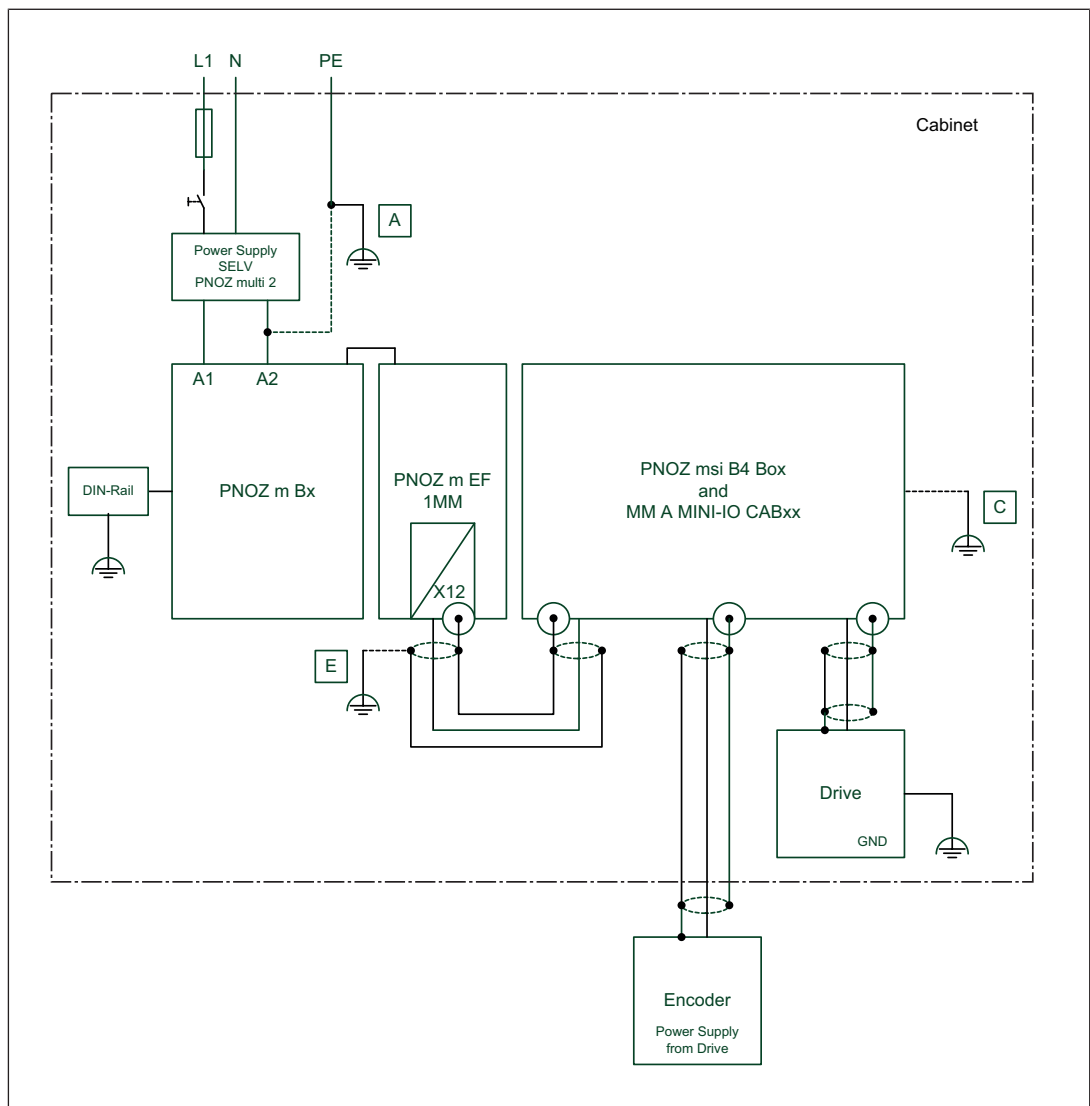

To avoid EMC interference we recommend that the shield on the sensor cable is connected to earth at **C** or **E**. Depending on the application, the connection to the functional earth may also be at a different location (here **A**).

EMC-compliant wiring for connecting an encoder and a proximity switch:

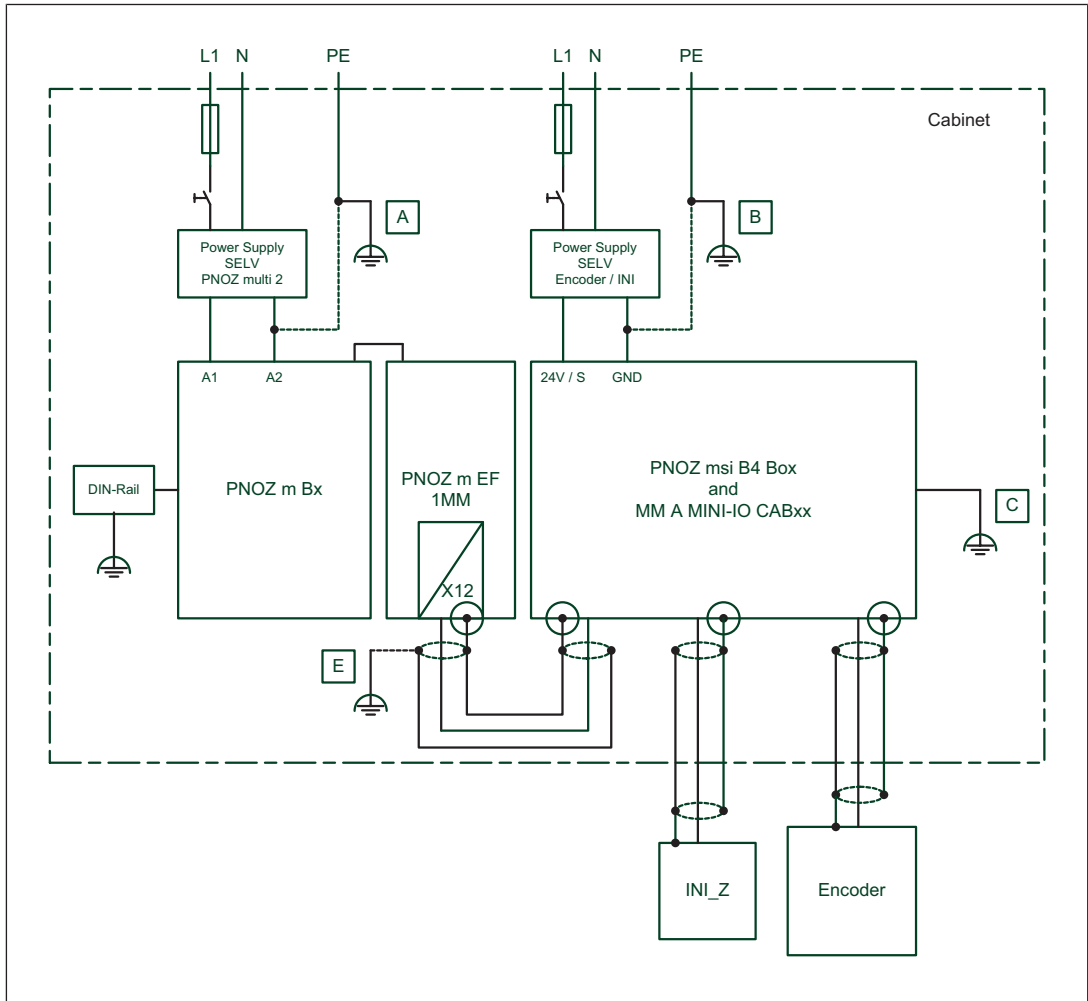

To avoid EMC interference we recommend that the shield on the sensor cable is connected to earth at **C** or **E**. Depending on the application, the connection to the functional earth may also be at a different location (here **A** or **B**).



## Technical details

<b>General</b>	
Certifications	<b>CE, UKCA, cULus Listed</b>
<b>Electrical data</b>	
Operating voltage	<b>30 V</b>
Rated voltage	
Voltage UB	<b>30 V</b>
Rated current	<b>1 A</b>
<b>Environmental data</b>	
Ambient temperature	
Temperature range	<b>0 - 60 °C</b>
Storage temperature	
Temperature range	<b>-25 - 70 °C</b>
Condensation during operation	<b>Not permitted</b>
Rated insulation voltage	<b>250 V</b>
Protection type	
In accordance with the standard	<b>EN 60529</b>
Housing	<b>IP20</b>
Terminals	<b>IP20</b>
Mounting area (e.g. control cabinet)	<b>IP54</b>
<b>Mechanical data</b>	
Material	
Housing	<b>Hot dip galvanised steel</b>
Connection type	<b>Spring-loaded terminal</b>
Mounting type	<b>Fixed</b>
Conductor cross section with spring-loaded terminals:	
Flexible with/without crimp connector	<b>0,08 - 1,5 mm<sup>2</sup>, 28 - 16 AWG</b>
Stripping length with spring-loaded terminals	<b>9 mm</b>
Dimensions	
Height	<b>103,1 mm</b>
Width	<b>25 mm</b>
Depth	<b>131,3 mm</b>
Weight	<b>280 g</b>

## Order reference

### Product

Product type	Features	Order No.
PNOZ msi b4 Box	Junction box	773845

### Accessories

Product type	Features	Order no.
PNOZ msi9p	Connection cable, 5.00 m	773856
PNOZ msi10p	Connection cable, 2.50 m	773854
PNOZ msi11p	Connection cable, 1.50 m	773855
MM A MINI-IO CAB99	Connection cable, 1.50 m	772200
MM A MINI-IO CAB99	Connection cable, 2.50 m	772201
MM A MINI-IO CAB99	Connection cable, 5.00 m	772202

# ► Support

Technical support is available from Pilz round the clock.

## Americas

### Brazil

+55 11 97569-2804

### Canada

+1 888 315 7459

### Mexico

+52 55 5572 1300

### USA (toll-free)

+1 877-PILZUSA (745-9872)

## Asia

### China

+86 21 60880878-216

### Japan

+81 45 471-2281

### South Korea

+82 31 778 3300

## Australia and Oceania

### Australia

+61 3 95600621

### New Zealand

+64 9 6345350

## Europe

### Austria

+43 1 7986263-0

### Belgium, Luxembourg

+32 9 3217570

### France

+33 3 88104003

### Germany

+49 711 3409-444

### Ireland

+353 21 4804983

### Italy, Malta

+39 0362 1826711

## Scandinavia

+45 74436332

## Spain

+34 938497433

## Switzerland

+41 62 88979-32

## The Netherlands

+31 347 320477

## Turkey

+90 216 5775552

## United Kingdom

+44 1536 462203

## You can reach our international hotline on:

+49 711 3409-222

support@pilz.com

Pilz develops environmentally-friendly products using ecological materials and energy-saving technologies. Offices and production facilities are ecologically designed, environmentally-aware and energy-saving. So Pilz offers sustainability, plus the security of using energy-efficient products and environmentally-friendly solutions.



We are represented internationally. Please refer to our homepage [www.pilz.com](http://www.pilz.com) for further details or contact our headquarters.

Headquarters: Pilz GmbH & Co. KG, Felix-Wankel-Straße 2, 73760 Ostfildern, Germany  
Telephone: +49 711 3409-0, Telefax: +49 711 3409-133, E-Mail: [info@pilz.com](mailto:info@pilz.com), Internet: [www.pilz.com](http://www.pilz.com)

**PILZ**  
THE SPIRIT OF SAFETY