

Visualisation; Diagnostics

Easy to Configure

Programming IEC 61131-3

Rapid Installation

## PNOZ p1p

► Safety relays

**PILZ**  
THE SPIRIT OF SAFETY

This document is a translation of the original document.

All rights to this documentation are reserved by Pilz GmbH & Co. KG. Copies may be made for internal purposes. Suggestions and comments for improving this documentation will be gratefully received.

Source code from third-party manufacturers or open source software has been used for some components. The relevant licence information is available on the Internet on the Pilz homepage.

Pilz®, PIT®, PMI®, PNOZ®, Primo®, PSEN®, PSS®, PVIS®, SafetyBUS p®, SafetyEYE®, SafetyNET p®, the spirit of safety® are registered and protected trademarks of Pilz GmbH & Co. KG in some countries.



SD means Secure Digital

<b>Introduction</b>	<b>4</b>
Validity of documentation	4
Using the documentation	4
Definition of symbols	4
<b>Safety</b>	<b>5</b>
Intended use	5
Safety regulations	5
Safety assessment	5
Use of qualified personnel	5
Warranty and liability	6
Disposal	6
<b>Unit features</b>	<b>7</b>
<b>Safety features</b>	<b>7</b>
<b>Block diagram/terminal configuration</b>	<b>7</b>
<b>Function Description</b>	<b>8</b>
Operating modes	8
Timing diagram	9
<b>Installation</b>	<b>9</b>
<b>Wiring</b>	<b>11</b>
<b>Preparing for operation</b>	<b>12</b>
<b>Operation</b>	<b>14</b>
Status indicators	14
<b>Faults – Interference</b>	<b>14</b>
<b>Dimensions in mm</b>	<b>15</b>
<b>Technical details</b>	<b>15</b>
Safety characteristic data	17
<b>Remove plug-in terminals</b>	<b>18</b>
<b>Order reference</b>	<b>18</b>
<b>EC declaration of conformity</b>	<b>19</b>

## Introduction

### Validity of documentation

This documentation is valid for the product PNOZ p1p. It is valid until new documentation is published.

This operating manual explains the function and operation, describes the installation and provides guidelines on how to connect the product.

### Using the documentation

This document is intended for instruction. Only install and commission the product if you have read and understood this document. The document should be retained for future reference.

### Definition of symbols

Information that is particularly important is identified as follows:



#### **DANGER!**

This warning must be heeded! It warns of a hazardous situation that poses an immediate threat of serious injury and death and indicates preventive measures that can be taken.



#### **WARNING!**

This warning must be heeded! It warns of a hazardous situation that could lead to serious injury and death and indicates preventive measures that can be taken.



#### **CAUTION!**

This refers to a hazard that can lead to a less serious or minor injury plus material damage, and also provides information on preventive measures that can be taken.



#### **NOTICE**

This describes a situation in which the product or devices could be damaged and also provides information on preventive measures that can be taken. It also highlights areas within the text that are of particular importance.

**INFORMATION**

This gives advice on applications and provides information on special features.

**Safety****Intended use**

The safety relay PNOZ p1p is a base unit of the safety system PNOZpower. It provides a safety-related interruption of a safety circuit.

The safety relay meets the requirements of EN 60947-5-1, EN 60204-1 and VDE 0113-1 and may be used in applications with

- ▶ E-STOP pushbuttons
- ▶ Safety gates

The following is deemed improper use in particular:

- ▶ Any component, technical or electrical modification to the product
- ▶ Use of the product outside the areas described in this manual
- ▶ Use of the product outside the technical details (see [Technical details](#) [ 15]).

**NOTICE****EMC-compliant electrical installation**

The product is designed for use in an industrial environment. The product may cause interference if installed in other environments. If installed in other environments, measures should be taken to comply with the applicable standards and directives for the respective installation site with regard to interference.

**Safety regulations****Safety assessment**

Before using a unit it is necessary to perform a safety assessment in accordance with the Machinery Directive.

Functional safety is guaranteed for the product as a single component. However, this does not guarantee the functional safety of the overall plant/machine. In order to achieve the required safety level for the overall plant/machine, define the safety requirements for the plant/machine and then define how these must be implemented from a technical and organisational standpoint.

**Use of qualified personnel**

The products may only be assembled, installed, programmed, commissioned, operated, maintained and decommissioned by competent persons.

A competent person is someone who, because of their training, experience and current professional activity, has the specialist knowledge required to test, assess and operate the work equipment, devices, systems, plant and machinery in accordance with the general standards and guidelines for safety technology.

It is the company's responsibility only to employ personnel who:

- ▶ Are familiar with the basic regulations concerning health and safety / accident prevention
- ▶ Have read and understood the information provided in this description under "Safety"
- ▶ And have a good knowledge of the generic and specialist standards applicable to the specific application.

### **Warranty and liability**

All claims to warranty and liability will be rendered invalid if

- ▶ The product was used contrary to the purpose for which it is intended
- ▶ Damage can be attributed to not having followed the guidelines in the manual
- ▶ Operating personnel are not suitably qualified
- ▶ Any type of modification has been made (e.g. exchanging components on the PCB boards, soldering work etc.).

### **Disposal**

- ▶ In safety-related applications, please comply with the mission time  $T_M$  in the safety-related characteristic data.
- ▶ When decommissioning, please comply with local regulations regarding the disposal of electronic devices (e.g. Electrical and Electronic Equipment Act).

## Unit features

- ▶ Connection options for:
  - E-STOP pushbutton
  - Safety gate limit switch
  - Start button
- ▶ Expansion module control output via PNOZpower bus
- ▶ 2 semiconductor outputs
- ▶ LED indicator for:
  - Supply voltage
  - Input status, channel 1
  - Input status, channel 2
  - Switch status of the output
  - Start circuit
  - Error
- ▶ Semiconductor outputs signal:
  - Supply voltage/fault
  - Switch status
- ▶ Max. 4 expansion modules can be connected via jumpers
- ▶ Plug-in connection terminals

## Safety features

The safety relay meets the following safety requirements:

- ▶ The circuit is redundant with built-in self-monitoring.
- ▶ The safety function remains effective in the case of a component failure.
- ▶ The correct opening and closing of the safety function relays is tested automatically in each on-off cycle.

## Block diagram/terminal configuration

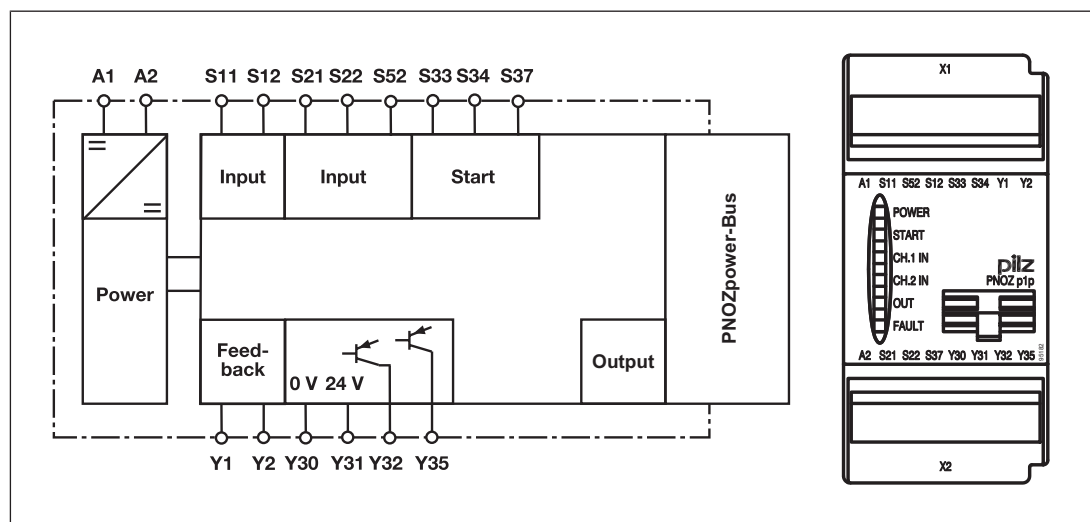

## Function Description

The base unit PNOZ p1p controls the expansion modules of the modular safety system via the PNOZpower bus and it is used in conjunction with the expansion modules for the safety-related interruption of a safety circuit.

When operating voltage is supplied the "POWER" LED will light. The unit is ready for operation when the feedback loop Y1-Y2 and the start circuit S33-S34 are closed. The "START" LED is lit.

- ▶ Input circuit is closed (e.g. E-STOP pushbutton is not operated):
  - The LEDs "CH.1 IN" and "CH.2 IN" are lit.
  - At the expansion module control output connected to the PNOZpower bus there is a high signal. The unit is active.
  - The "OUT" status display will illuminate.
  - The "START" LED goes out.
  - A high signal is present at the semiconductor output switch state Y32.
- ▶ Input circuit is opened (e.g. E-STOP pushbutton operated):
  - The LEDs "CH.1 IN" and "CH.2 IN" go out.
  - At the expansion module control output connected to the PNOZpower bus there is a low signal.
  - The "OUT" status display will go out.
  - A low signal is present at the semiconductor output switch state Y32.

Semiconductor output supply voltage/fault Y35

- ▶ A high signal is present at semi-conductor output Y35 if the supply voltage is present and the internal fuse has not blown. If there is a fault on the PNOZ p1p or on an expansion module, there is low signal at Y35.



### NOTICE

When controlling an expansion module via the den PNOZpower bus the switch-on delay/delay-on de-energisation of the controlling device (e.g base unit, control module, ...) and the expansion module are added together.

## Operating modes

- ▶ Single-channel operation: No redundancy in the input circuit, earth faults in the start and input circuit are detected.
- ▶ Dual-channel operation with detection of shorts across contacts: Redundant input circuit, PNOZ p1p detects
  - earth faults in the start and input circuit,
  - short circuits in the input circuit,
  - shorts across contacts in the input circuit.
- ▶ Automatic start: Unit is active once the input circuit has been closed.
- ▶ Manual start: Unit is active once the input circuit and the start circuit are closed.



- ▶ Monitored start: Unit is active once
  - the input circuit is closed and then the start circuit is closed and opened again.
  - the start circuit is closed and then opened again once the input circuit is closed.

### Timing diagram

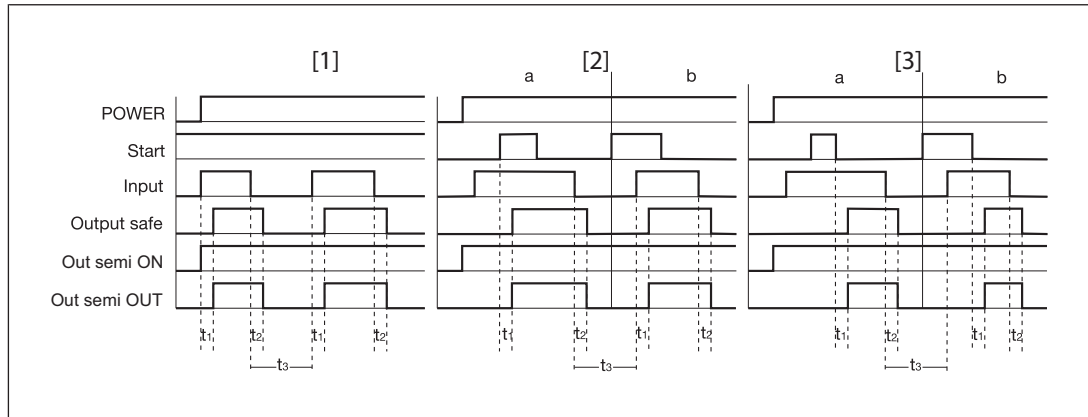

### Legend

- ▶ Power: Supply voltage
- ▶ Start: Start circuit
- ▶ Input: Input circuit
- ▶ Output safe: Output to PNOZpower bus
- ▶ Out semi ON: Semiconductor output supply voltage/fault
- ▶ Out semi OUT: Semiconductor output switch state
- ▶ [1]: Automatic start
- ▶ [2]: Manual start
- ▶ [3]: Monitored start
- ▶ a: Input circuit closes before start circuit
- ▶ b: Start circuit closes before input circuit
- ▶  $t_1$ : Switch-on delay
- ▶  $t_2$ : Delay-on de-energisation
- ▶  $t_3$ : Recovery time

### Installation

- ▶ The unit should be installed in a control cabinet with a protection type of at least IP54.
- ▶ Use the notches on the rear of the unit to attach it to a DIN rail.
- ▶ Fit the unit to a horizontal DIN rail. If other mounting positions are used, the switching capability values stated in the technical details cannot be maintained.
- ▶ There are 2 sockets on the rear of the PNOZ p1p.  
The base unit/control module and the expansion modules are connected using the jumpers supplied.

**NOTICE**

Always connect a terminator to the first and last device.

- ▶ Only use terminators, jumpers and terminals of the modular safety system PNOZpower.
- ▶ Layout:
  - The base module and the expansion modules can be installed in any position on the PNOZpower modular safety system.
- ▶ Maximum hardware:
  - 1 base unit
  - 4 expansion modules
  - 1 power supply unit

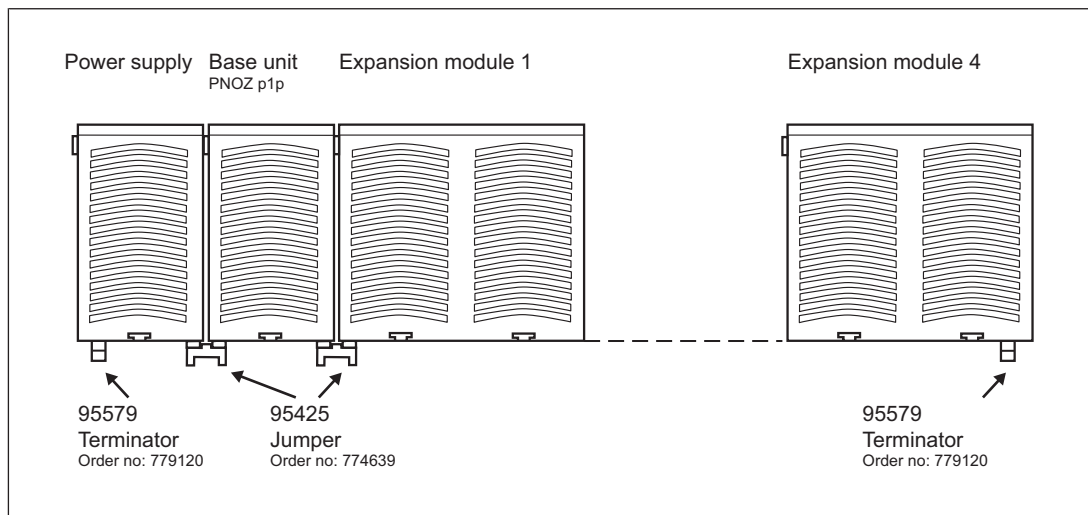
**WARNING!**

Risk of electrocution!

When voltage is applied, contact with live components could result in serious or even fatal injury from an electric shock.

The plug-in connection terminals should only be connected and disconnected when the voltage is switched off.

## Wiring

Please note:

- ▶ Information given in the "Technical details  15]" must be followed.
- ▶ Semiconductor outputs should **not** be used for safety circuits!
- ▶ Calculation of the max. cable runs  $I_{\max}$  in the input circuit:

$$I_{\max} = \frac{R_{l_{\max}}}{R_l / \text{km}}$$

$R_{l_{\max}}$  = max. overall cable resistance (see Technical details  15])  
 $R_l / \text{km}$  = cable resistance/km

- ▶ Use copper wire that can withstand 60/75 °C.
- ▶ When connecting magnetically operated, reed proximity switches, ensure that the max. peak inrush current (on the input circuit) does not overload the proximity switch.
- ▶ Use the power supply PNOZ pps1p, or an external power supply that complies with the regulations for extra low voltages with safe electrical separation (SELV, PELV) in accordance with VDE 0100, Part 410.
- ▶ Ensure the EMC requirements of IEC 60204-1 are met.

### Important for detection of shorts across contacts:

As this function for detecting shorts across contacts is not failsafe, it is tested by Pilz during the final control check. If there is a danger of exceeding the cable length, we recommend the following test after the installation of the device:

1. Unit active (the LEDs "POWER", "CH.1 IN", "CH.2 IN" and "OUT" are lit).
2. Short circuit the test terminals S12, S22 for detecting shorts across the inputs.
3. The unit's fuse must be triggered (only the "FAULT" LED is lit). Cable lengths in the scale of the maximum length can delay the fuse triggering for up to 2 minutes.
4. Reset the fuse: Remove the short circuit and switch off the supply voltage for approx. 1 minute.

### Preparing for operation

Supply voltage	AC	DC



**NOTICE**

When the PNOZ pps1p power supply unit is used, the unit draws power via the PNOZpower bus. Do not connect an external supply voltage to A1 and A2!

Input circuit	Single-channel	Dual-channel
E-STOP <b>without</b> detection of shorts across contacts		
E-STOP <b>with</b> detection of shorts across contacts		
Safety gate <b>without</b> detection of shorts across contacts		
Safety gate <b>with</b> detection of shorts across contacts		
Light beam device <b>with</b> detection of shorts across contacts via ESPE		

Start circuit	E-STOP/safety gate wiring (single-channel and dual-channel without detection of shorts across contacts)	E-STOP/safety gate wiring (dual-channel with detection of shorts across contacts)
Automatic start		
Manual start		
Monitored start		



**NOTICE**

In the event of an automatic start or manual start with bridged start contact (fault):



The unit starts up automatically when the safeguard is reset, e.g. when the E-STOP pushbutton is released. Use external circuit measures to prevent an unexpected restart.

Feedback loop	Automatic start	Monitored start
Contacts from external contactors	<p><b>Base unit</b></p> <p><b>Expansion module</b></p>	<p><b>Base unit</b></p> <p><b>Expansion module</b></p>

Semiconductor output

**Legend**

- ▶ S1: E-STOP pushbuttons

- ▶ S3: Start button
- ▶ : Switch operated
- ▶ : Gate open
- ▶ : Gate closed

## Operation



### NOTICE

The safety function should be checked after initial commissioning and each time the plant/machine is changed. The safety functions may only be checked by qualified personnel.

## Status indicators

LEDs indicate the status and errors during operation:



LED on



### POWER

Supply voltage is present.



### START

Start circuit is closed.



### CH.1 IN

Channel 1 input circuit is closed.



### CH.2 IN

Channel 2 input circuit is closed.



### OUT

The output on the PNOZpower bus and the semiconductor output Y32 have a high signal.



### FAULT

Earth fault or short across contacts has occurred.

## Faults – Interference

- ▶ Earth fault or short across contacts  
The supply voltage fails and the safety contacts open via an electronic fuse. Once the cause of the respective fault has been removed and the supply voltage is switched off for approx. 1 minute, the unit is ready for operation again.
- ▶ LED "POWER" does not light: Short circuit or no supply voltage.
- ▶ Error at an PNOZ p1p expansion module: Semiconductor output Y35 has a Low signal.

### Dimensions in mm

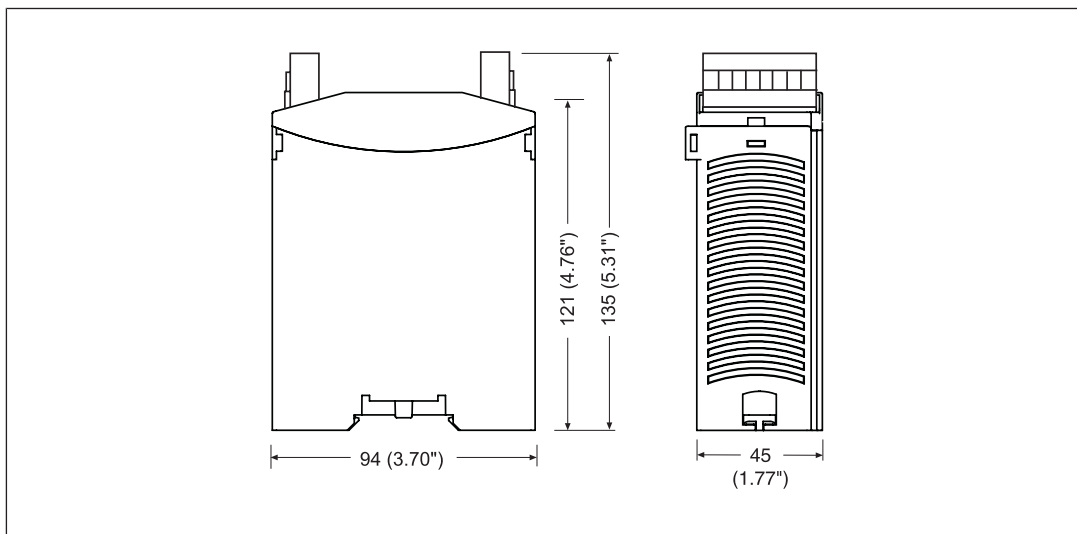

### Technical details

#### General

Approvals **CCC, CE, EAC (Eurasian), TÜV, cULus Listed**

#### Electrical data

Supply voltage

Voltage	<b>24 V</b>
Kind	<b>DC</b>
Voltage tolerance	<b>-15 %/+10 %</b>
Power consumption	<b>3 W</b>
Residual ripple DC	<b>160 %</b>

Duty cycle **100 %**

#### Inputs

Number **2**

Voltage at

Input circuit DC	<b>24 V</b>
Start circuit DC	<b>24 V</b>
Feedback loop DC	<b>24 V</b>

Current at

Input circuit DC	<b>50 mA</b>
Start circuit DC	<b>50 mA</b>
Feedback loop DC	<b>50 mA</b>

Min. input resistance at power-on **252 Ohm**

Max. overall cable resistance R<sub>lmax</sub>

Single-channel at UB DC	<b>60 Ohm</b>
Dual-channel without detection of shorts across contacts at UB DC	<b>120 Ohm</b>
Dual-channel with detection of shorts across contacts at UB DC	<b>30 Ohm</b>

<b>Semiconductor outputs</b>	
Number	<b>2</b>
Voltage	<b>24 V</b>
Current	<b>20 mA</b>
External supply voltage	<b>24 V</b>
Voltage tolerance	<b>-20 %/+20 %</b>
<b>Times</b>	
Switch-on delay	
With automatic start max.	<b>250 ms</b>
With manual start max.	<b>250 ms</b>
With monitored start with rising edge max.	<b>180 ms</b>
Delay-on de-energisation	
With E-STOP max.	<b>25 ms</b>
With power failure max.	<b>1 s</b>
Recovery time at max. switching frequency 1/s	
After E-STOP	<b>300 ms</b>
After power failure	<b>300 ms</b>
Supply interruption before de-energisation	<b>20 ms</b>
Simultaneity, channel 1 and 2 max.	<b>150 ms</b>
<b>Environmental data</b>	
Climatic suitability	<b>EN 60068-2-78</b>
Ambient temperature	
Temperature range	<b>-10 - 55 °C</b>
Storage temperature	
Temperature range	<b>-40 - 85 °C</b>
Climatic suitability	
Humidity	<b>93 % r. h. at 40 °C</b>
Condensation during operation	<b>Not permitted</b>
EMC	<b>EN 60947-5-1, EN 61000-6-2, EN 61326-3-1</b>
Vibration	
In accordance with the standard	<b>EN 60068-2-6</b>
Frequency	<b>10 - 55 Hz</b>
Amplitude	<b>0,35 mm</b>
Airgap creepage	
In accordance with the standard	<b>EN 60947-1</b>
Overvoltage category	<b>III</b>
Pollution degree	<b>2</b>
Rated insulation voltage	<b>30 V</b>
Rated impulse withstand voltage	<b>0,8 kV</b>
Protection type	
Mounting area (e.g. control cabinet)	<b>IP54</b>
Housing	<b>IP30</b>
Terminals	<b>IP20</b>
<b>Mechanical data</b>	
Mounting position	<b>Horizontal on top hat rail</b>



**Mechanical data**

Material	
Bottom	<b>PPO UL 94 V0</b>
Top	<b>ABS UL 94 V0</b>
Connection type	<b>Screw terminal</b>
Mounting type	<b>plug-in</b>
Conductor cross section with screw terminals	
1 core flexible	<b>0,5 - 2,5 mm<sup>2</sup>, 24 - 12 AWG</b>
2 core with the same cross section, flexible with crimp connectors, no plastic sleeve	<b>0,5 - 1 mm<sup>2</sup>, 24 - 16 AWG</b>
2 core with the same cross section, flexible without crimp connectors or with TWIN crimp connectors	<b>0,5 - 1,5 mm<sup>2</sup>, 24 - 16 AWG</b>
Torque setting with screw terminals	<b>0,5 Nm</b>
Dimensions	
Height	<b>94 mm</b>
Width	<b>45 mm</b>
Depth	<b>135 mm</b>
Weight	<b>285 g</b>

Where standards are undated, the 2014-07 latest editions shall apply.

**Safety characteristic data****NOTICE**

You must comply with the safety-related characteristic data in order to achieve the required safety level for your plant/machine.

Operating mode	EN ISO 13849-1: 2008	EN ISO 13849-1: 2008	EN 62061 SIL CL	EN 62061 PFH <sub>D</sub> [1/h]	IEC 61511 SIL	IEC 61511 PFD	EN ISO 13849-1: 2008 T <sub>M</sub> [year]
	PL	Category					
–	<b>PL e</b>	<b>Cat. 4</b>	<b>SIL CL 3</b>	<b>2,31E-09</b>	<b>SIL 3</b>	<b>2,03E-06</b>	<b>20</b>

All the units used within a safety function must be considered when calculating the safety characteristic data.

**INFORMATION**

A safety function's SIL/PL values are **not** identical to the SIL/PL values of the units that are used and may be different. We recommend that you use the PAScal software tool to calculate the safety function's SIL/PL values.

## Remove plug-in terminals

Procedure: Insert the screwdriver into the housing recess behind the terminal and lever the terminal out.

Do **not** remove the terminals by pulling the cables!

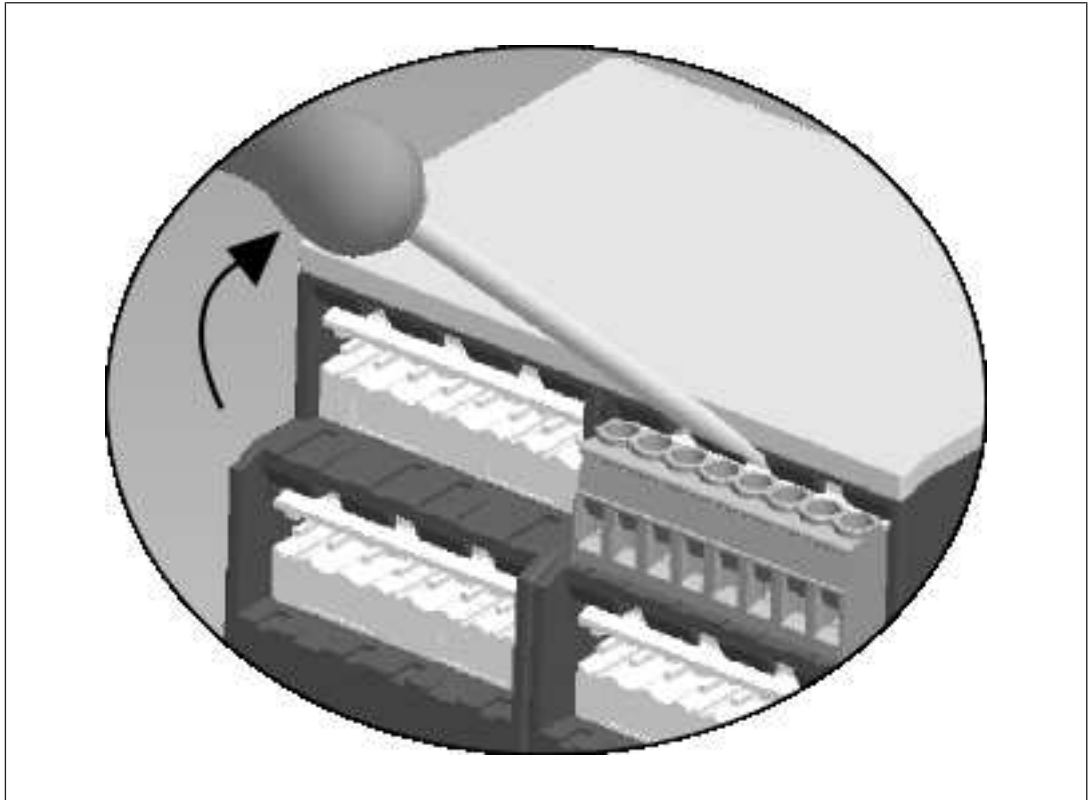

### WARNING!

Risk of electrocution!

When voltage is applied, contact with live components could result in serious or even fatal injury from an electric shock.

The plug-in connection terminals should only be connected and disconnected when the voltage is switched off.

## Order reference

Product type	Features	Connection type	Order No.
PNOZ p1p	24 VDC	Screw terminals	773 300

**EC declaration of conformity**

This product/these products meet the requirements of the directive 2006/42/EC for machinery of the European Parliament and of the Council. The complete EC Declaration of Conformity is available on the Internet at [www.pilz.com/support/downloads](http://www.pilz.com/support/downloads).

Representative: Norbert Fröhlich, Pilz GmbH & Co. KG, Felix-Wankel-Str. 2, 73760 Ostfildern, Germany

# ► Support

Technical support is available from Pilz round the clock.

## Americas

**Brazil**  
+55 11 97569-2804

**Canada**  
+1 888-315-PILZ (315-7459)

**Mexico**  
+52 55 5572 1300

**USA (toll-free)**  
+1 877-PILZUSA (745-9872)

## Asia

**China**  
+86 21 60880878-216

**Japan**  
+81 45 471-2281

**South Korea**  
+82 31 450 0680

## Australia

+61 3 95446300

## Europe

**Austria**  
+43 1 7986263-0

**Belgium, Luxembourg**  
+32 9 3217575

**France**  
+33 3 88104000

**Germany**  
+49 711 3409-444

**Ireland**  
+353 21 4804983

**Italy**  
+39 0362 1826711

## Scandinavia

+45 74436332

## Spain

+34 938497433

## Switzerland

+41 62 88979-30

## The Netherlands

+31 347 320477

## Turkey

+90 216 5775552

## United Kingdom

+44 1536 462203

## You can reach our international hotline on:

+49 711 3409-444  
support@pilz.com

Pilz develops environmentally-friendly products using ecological materials and energy-saving technologies. Offices and production facilities are ecologically designed, environmentally-aware and energy-saving. So Pilz offers sustainability, plus the security of using energy-efficient products and environmentally-friendly solutions.



Pilz GmbH & Co. KG  
Felix-Wankel-Straße 2  
73760 Ostfildern, Germany  
Tel.: +49 711 3409-0  
Fax: +49 711 3409-133  
info@pilz.com  
www.pilz.com

