

Visualisation; Diagnostics

Easy to Configure

Programming IEC 61131-3

Rapid Installation

PNOZ p1vp

► Safety relays

PILZ
THE SPIRIT OF SAFETY

This document is a translation of the original document.

All rights to this documentation are reserved by Pilz GmbH & Co. KG. Copies may be made for internal purposes. Suggestions and comments for improving this documentation will be gratefully received.

Source code from third-party manufacturers or open source software has been used for some components. The relevant licence information is available on the Internet on the Pilz homepage.

Pilz®, PIT®, PMI®, PNOZ®, Primo®, PSEN®, PSS®, PVIS®, SafetyBUS p®, SafetyEYE®, SafetyNET p®, the spirit of safety® are registered and protected trademarks of Pilz GmbH & Co. KG in some countries.



SD means Secure Digital

Introduction	4
Validity of documentation	4
Using the documentation	4
Definition of symbols	4
Safety	5
Intended use	5
Safety regulations	5
Safety assessment	5
Use of qualified personnel	5
Warranty and liability	6
Disposal	6
Unit features	7
Safety features	7
Block diagram/terminal configuration	8
Function Description	8
Operating modes	9
Timing diagram	9
Installation	10
Wiring	11
Preparing for operation	12
Operation	15
Status indicators	15
Faults – Interference	15
Dimensions in mm	16
Technical details	16
Safety characteristic data	19
Remove plug-in terminals	20
Order reference	20
EC declaration of conformity	21

Introduction

Validity of documentation

This documentation is valid for the product PNOZ p1vp. It is valid until new documentation is published.

This operating manual explains the function and operation, describes the installation and provides guidelines on how to connect the product.

Using the documentation

This document is intended for instruction. Only install and commission the product if you have read and understood this document. The document should be retained for future reference.

Definition of symbols

Information that is particularly important is identified as follows:



DANGER!

This warning must be heeded! It warns of a hazardous situation that poses an immediate threat of serious injury and death and indicates preventive measures that can be taken.



WARNING!

This warning must be heeded! It warns of a hazardous situation that could lead to serious injury and death and indicates preventive measures that can be taken.



CAUTION!

This refers to a hazard that can lead to a less serious or minor injury plus material damage, and also provides information on preventive measures that can be taken.



NOTICE

This describes a situation in which the product or devices could be damaged and also provides information on preventive measures that can be taken. It also highlights areas within the text that are of particular importance.

**INFORMATION**

This gives advice on applications and provides information on special features.

Safety**Intended use**

The safety relay PNOZ p1vp is a base unit of the safety system PNOZpower. It provides a safety-related interruption of a safety circuit.

The safety relay meets the requirements of EN 60947-5-1, EN 60204-1 and VDE 0113-1 and may be used in applications with

- ▶ E-STOP pushbuttons
- ▶ Safety gates

The following is deemed improper use in particular:

- ▶ Any component, technical or electrical modification to the product
- ▶ Use of the product outside the areas described in this manual
- ▶ Use of the product outside the technical details (see [Technical details](#) [ 16]).

**NOTICE****EMC-compliant electrical installation**

The product is designed for use in an industrial environment. The product may cause interference if installed in other environments. If installed in other environments, measures should be taken to comply with the applicable standards and directives for the respective installation site with regard to interference.

Safety regulations**Safety assessment**

Before using a unit it is necessary to perform a safety assessment in accordance with the Machinery Directive.

Functional safety is guaranteed for the product as a single component. However, this does not guarantee the functional safety of the overall plant/machine. In order to achieve the required safety level for the overall plant/machine, define the safety requirements for the plant/machine and then define how these must be implemented from a technical and organisational standpoint.

Use of qualified personnel

The products may only be assembled, installed, programmed, commissioned, operated, maintained and decommissioned by competent persons.

A competent person is someone who, because of their training, experience and current professional activity, has the specialist knowledge required to test, assess and operate the work equipment, devices, systems, plant and machinery in accordance with the general standards and guidelines for safety technology.

It is the company's responsibility only to employ personnel who:

- ▶ Are familiar with the basic regulations concerning health and safety / accident prevention
- ▶ Have read and understood the information provided in this description under "Safety"
- ▶ And have a good knowledge of the generic and specialist standards applicable to the specific application.

Warranty and liability

All claims to warranty and liability will be rendered invalid if

- ▶ The product was used contrary to the purpose for which it is intended
- ▶ Damage can be attributed to not having followed the guidelines in the manual
- ▶ Operating personnel are not suitably qualified
- ▶ Any type of modification has been made (e.g. exchanging components on the PCB boards, soldering work etc.).

Disposal

- ▶ In safety-related applications, please comply with the mission time T_M in the safety-related characteristic data.
- ▶ When decommissioning, please comply with local regulations regarding the disposal of electronic devices (e.g. Electrical and Electronic Equipment Act).

Unit features

- ▶ Connection options for:
 - E-STOP pushbutton
 - Safety gate limit switch
 - Start button
- ▶ instantaneous and delay-on de-energisation control of the expansion modules via the PNOZpower bus
- ▶ 2 semiconductor outputs
- ▶ Delay time can be set via rotary switches
- ▶ LED indicator for:
 - Supply voltage
 - Input status, channel 1
 - Input status, channel 2
 - Switch status of the output
 - Start circuit
 - Error
- ▶ Semiconductor outputs signal:
 - Supply voltage/fault
 - Switch status
- ▶ Max. 8 expansion modules can be connected via jumpers:
 - max. 4 expansion modules that are controlled instantaneously,
 - max. 4 expander modules that are controlled with a delay time
- ▶ Plug-in connection terminals
- ▶ See order reference for unit types

Safety features

The safety relay meets the following safety requirements:

- ▶ The circuit is redundant with built-in self-monitoring.
- ▶ The safety function remains effective in the case of a component failure.
- ▶ The correct opening and closing of the safety function relays is tested automatically in each on-off cycle.

Block diagram/terminal configuration

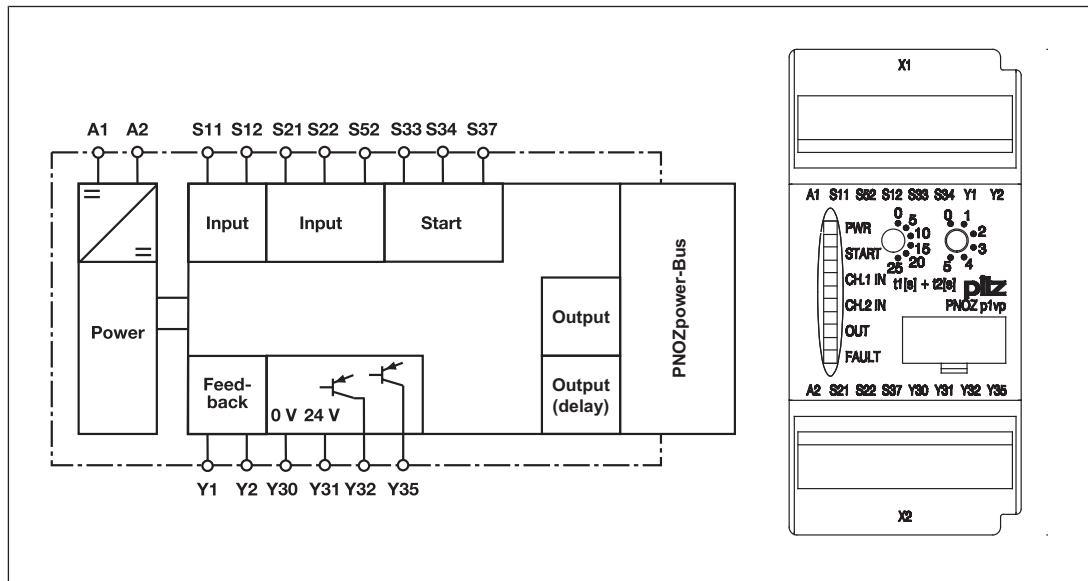

Function Description

The base unit PNOZ p1vp controls the expansion modules of the modular safety system via the PNOZpower bus and it is used in conjunction with the expansion modules for the safety-related interruption of a safety circuit.

When operating voltage is supplied the "PWR" LED will light. The unit is ready for operation when the feedback loop Y1-Y2 and the start circuit S33-S34 are closed. The "START" LED is lit.

- ▶ Input circuit is closed (e.g. E-STOP pushbutton not operated):
 - The LEDs "CH.1 IN" and "CH.2 IN" are lit.
 - There is a high signal at the expansion module output for instantaneous control of the expansion modules connected to the PNOZpower bus. The unit is active.
 - The "OUT" status display will illuminate.
 - The "START" LED goes out.
 - A high signal is present at the semiconductor output switch state Y32.
- ▶ Input circuit is opened (e.g. E-STOP pushbutton operated):
 - The LEDs "CH.1 IN" and "CH.2 IN" go out.
 - At the expansion module control output connected to the PNOZpower bus there is a low signal.
 - The "OUT" status display will go out.
 - A low signal is present at the semiconductor output switch state Y32.
 - Once the set delay time has elapsed there is a low signal at the output for delayed control of the expansion modules on the PNOZpower bus.

Semiconductor output supply voltage/fault Y35

- ▶ A high signal is present at semi-conductor output Y35 if the supply voltage is present and the internal fuse has not blown. If there is a fault on the PNOZ p1vp or on an expansion module, there is low signal at Y35.

- ▶ [1]: Automatic start
- ▶ [2]: Manual start
- ▶ [3]: Monitored start
- ▶ a: Input circuit closes before start circuit
- ▶ b: Start circuit closes before input circuit
- ▶ t_a : Switch-on delay
- ▶ t_b : Delay-on de-energisation
- ▶ t_3 : Recovery time
- ▶ t_v : Delay time

**NOTICE**

The delay-on de-energisation safety contacts open, even when a component fails, at the latest after the set delay time + 20 ms + 15% of the set value and the maximum delay-on de-energisation of the expansion module.

Installation

- ▶ The unit should be installed in a control cabinet with a protection type of at least IP54.
- ▶ Use the notches on the rear of the unit to attach it to a DIN rail.
- ▶ Fit the unit to a horizontal DIN rail. If other mounting positions are used, the switching capability values stated in the technical details cannot be maintained.
- ▶ There are 2 sockets on the rear of the PNOZ p1vp.
The base unit/control module and the expansion modules are connected using the jumpers supplied.

**NOTICE**

Always connect a terminator to the first and last device.

- ▶ Only use terminators, jumpers and terminals of the modular safety system PNOZpower.
- ▶ Layout:
 - The base module and the expansion modules can be installed in any position on the PNOZpower modular safety system.
 - Expansion modules installed to the left of the base unit are controlled instantaneously, expansion modules installed to the right of the base unit are controlled with a time delay.
 - When using the power supply PNOZ pps1p: Install a power supply to the left of the base unit for instantaneously controlled expansion modules and a power supply to the right of the base unit for expansion modules controlled with a delay time.
- ▶ Maximum hardware:
 - 1 base unit
 - 4 expansion modules that are controlled instantaneously

- 4 expansion modules that are controlled with a delay time
- 2 power supplies (one device each for delayed and instantaneous expansion modules)

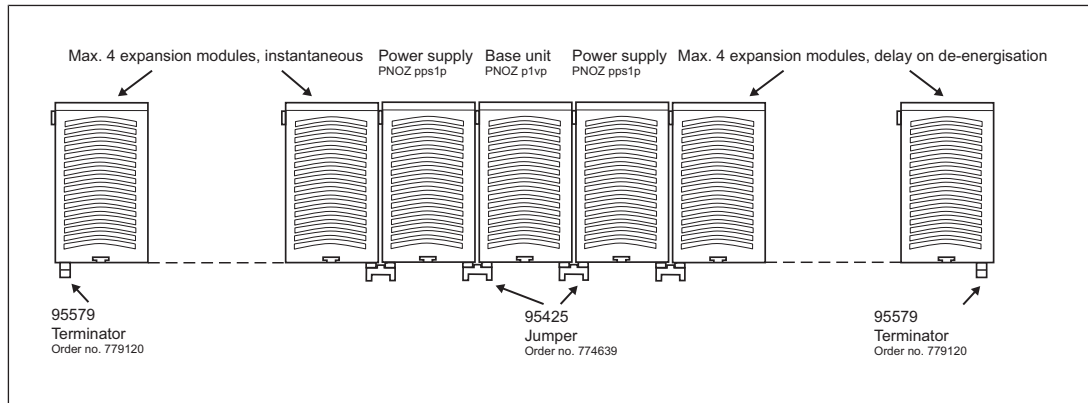

WARNING!

Risk of electrocution!

When voltage is applied, contact with live components could result in serious or even fatal injury from an electric shock.

The plug-in connection terminals should only be connected and disconnected when the voltage is switched off.

Wiring

Please note:

- ▶ Information given in the "[Technical details \[16\]](#)" must be followed.
- ▶ Delivery condition: Link between Y1-Y2 (feedback loop)
- ▶ Semiconductor outputs should **not** be used for safety circuits!
- ▶ Calculation of the max. cable runs I_{max} in the input circuit:

$$I_{max} = \frac{R_{I_{max}}}{R_l / km}$$

$R_{I_{max}}$ = max. overall cable resistance (see [Technical details \[16\]](#))

R_l / km = cable resistance/km

- ▶ Use copper wire that can withstand 60/75 °C.
- ▶ When connecting magnetically operated, reed proximity switches, ensure that the max. peak inrush current (on the input circuit) does not overload the proximity switch.
- ▶ Use the power supply PNOZ pps1p, or an external power supply that complies with the regulations for extra low voltages with safe electrical separation (SELV, PELV) in accordance with VDE 0100, Part 410.
- ▶ Ensure the wiring and EMC requirements of IEC 60204-1 are met.

Important for detection of shorts across contacts:

As this function for detecting shorts across contacts is not failsafe, it is tested by Pilz during the final control check. If there is a danger of exceeding the cable length, we recommend the following test after the installation of the device:

1. Unit active (the LEDs "PWR", "CH.1 IN", "CH.2 IN" and "OUT" are lit).
2. Short circuit the test terminals S12, S22 for detecting shorts across the inputs.
3. The unit's fuse must be triggered (only the "FAULT" LED is lit). Cable lengths in the scale of the maximum length can delay the fuse triggering for up to 2 minutes.
4. Reset the fuse: Remove the short circuit and switch off the supply voltage for approx. 1 minute.

Preparing for operation**Set delay time**

The delay time results for the addition of the times set by the two rotary switches.

Examples:

- ▶ Unit type with a delay time of 30 s:
 - Required delay time: 7 s
 - Setting: left rotary switch: 5, right rotary switch: 2
- ▶ Unit type with a delay time of 300 s:
 - Required delay time: 240 s
 - Setting: left rotary switch: 200, right rotary switch: 40

Supply voltage	AC	DC



NOTICE

When the PNOZ pps1p power supply unit is used, the unit draws power via the PNOZpower bus. Do not connect an external supply voltage to A1 and A2!

Input circuit	Single-channel	Dual-channel
E-STOP without detection of shorts across contacts		
E-STOP with detection of shorts across contacts		
Safety gate without detection of shorts across contacts		
Safety gate with detection of shorts across contacts		
Light beam device with detection of shorts across contacts via ESPE		

Start circuit	E-STOP/safety gate wiring (single-channel and dual-channel without detection of shorts across contacts)	E-STOP/safety gate wiring (dual-channel with detection of shorts across contacts)
Automatic start		
Manual start		
Monitored start		



NOTICE



In the event of an automatic start or manual start with bridged start contact (fault):

The unit starts up automatically when the safeguard is reset, e.g. when the E-STOP pushbutton is released. Use external circuit measures to prevent an unexpected restart.

Feedback loop	with feedback loop monitoring	without feedback loop monitoring
Link or contacts from external contactors	<p>Base unit</p> <p>Expansion module</p>	

Semiconductor output	
Y31, Y30: External supply voltage	

Legend

- ▶ S1: E-STOP pushbuttons
- ▶ S3: Start button
- ▶ : Switch operated
- ▶ : Gate open
- ▶ : Gate closed

Operation



NOTICE

The safety function should be checked after initial commissioning and each time the plant/machine is changed. The safety functions may only be checked by qualified personnel.

Status indicators

LEDs indicate the status and errors during operation:



LED on



PWR

Supply voltage is present.



START

Start circuit is closed.



CH.1 IN

Channel 1 input circuit is closed.



CH.2 IN

Channel 2 input circuit is closed.



OUT

The output on the PNOZpower bus and the semiconductor output Y32 have a high signal.



FAULT

Earth fault or short across contacts has occurred.

Faults – Interference

- ▶ Earth fault or short across contacts
The supply voltage fails and the safety contacts open via an electronic fuse. Once the cause of the respective fault has been removed and the supply voltage is switched off for approx. 1 minute, the unit is ready for operation again.
- ▶ LED "PWR" does not light: Short circuit or no supply voltage.

- ▶ Error at an PNOZ p1vp expansion module: Semiconductor output Y35 has a Low signal.

Dimensions in mm

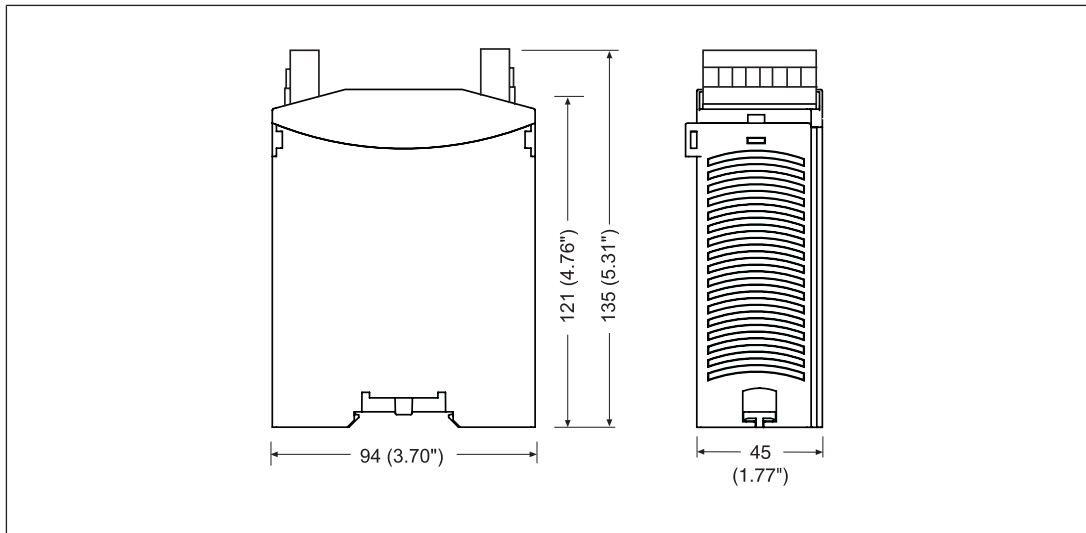

Technical details

General	773950	773951
Approvals	CCC, CE, EAC (Eurasian), TÜV, cULus Listed	CCC, CE, EAC (Eurasian), TÜV, cULus Listed
Electrical data	773950	773951
Supply voltage		
Voltage	24 V	24 V
Kind	DC	DC
Voltage tolerance	-15 %/+10 %	-15 %/+10 %
Power consumption	4 W	4 W
Residual ripple DC	160 %	160 %
Duty cycle	100 %	100 %
Inputs	773950	773951
Number	2	2
Voltage at		
Input circuit DC	24 V	24 V
Start circuit DC	24 V	24 V
Feedback loop DC	24 V	24 V
Current at		
Input circuit DC	40 mA	40 mA
Start circuit DC	340 mA	340 mA
Feedback loop DC	40 mA	40 mA
Min. input resistance at power-on	70 Ohm	70 Ohm

Inputs	773950	773951
Max. overall cable resistance RI-max		
Single-channel at UB DC	60 Ohm	60 Ohm
Dual-channel without detection of shorts across contacts at UB DC	120 Ohm	120 Ohm
Dual-channel with detection of shorts across contacts at UB DC	30 Ohm	30 Ohm
Semiconductor outputs	773950	773951
Number	2	2
Voltage	24 V	24 V
Current	20 mA	20 mA
External supply voltage	24 V	24 V
Voltage tolerance	-15 %/+10 %	-15 %/+10 %
Times	773950	773951
Switch-on delay		
With automatic start max.	250 ms	250 ms
With automatic start after power on max.	270 ms	270 ms
With manual start max.	250 ms	250 ms
With monitored start with rising edge max.	210 ms	210 ms
Delay-on de-energisation		
With E-STOP max.	30 ms	30 ms
With power failure max.	70 ms	70 ms
Recovery time at max. switching frequency 1/s		
After E-STOP	1 s	1 s
After power failure	1 s	1 s
Selectable delay times	0,3 ... 5 s, 10 ... 15 s, 15 ... 20 s, 20 ... 25 s, 25 ... 30 s, 5 ... 10 s	1,5 ... 50 s, 100 ... 150 s, 150 ... 200 s, 200 ... 250 s, 250 ... 300 s, 50 ... 100 s
Time accuracy based on range end value	+/-15 % +20 ms	+/-15 % +20 ms
Supply interruption before de-energisation	20 ms	20 ms
Simultaneity, channel 1 and 2 max.	210 ms	210 ms
Environmental data	773950	773951
Climatic suitability	EN 60068-2-78	EN 60068-2-78
Ambient temperature		
Temperature range	-10 - 55 °C	-10 - 55 °C
Storage temperature		
Temperature range	-40 - 85 °C	-40 - 85 °C
Climatic suitability		
Humidity	93 % r. h. at 40 °C	93 % r. h. at 40 °C
Condensation during operation	Not permitted	Not permitted

Environmental data	773950	773951
EMC	EN 60947-5-1, EN 61000-6-2, EN 61326-3-1	EN 60947-5-1, EN 61000-6-2, EN 61326-3-1
Vibration		
In accordance with the standard	EN 60068-2-6	EN 60068-2-6
Frequency	10 - 55 Hz	10 - 55 Hz
Amplitude	0,35 mm	0,35 mm
Airgap creepage		
In accordance with the standard	EN 60947-1	EN 60947-1
Overvoltage category	III	III
Pollution degree	2	2
Rated insulation voltage	30 V	30 V
Rated impulse withstand voltage	0,8 kV	0,8 kV
Protection type		
Mounting area (e.g. control cabinet)	IP54	IP54
Housing	IP30	IP30
Terminals	IP20	IP20
Mechanical data	773950	773951
Mounting position	Horizontal on top hat rail	Horizontal on top hat rail
Material		
Bottom	PPO UL 94 V0	PPO UL 94 V0
Top	ABS UL 94 V0	ABS UL 94 V0
Connection type	Screw terminal	Screw terminal
Mounting type	plug-in	plug-in
Conductor cross section with screw terminals		
1 core flexible	0,2 - 2,5 mm ² , 24 - 12 AWG	0,2 - 2,5 mm ² , 24 - 12 AWG
2 core with the same cross section, flexible with crimp connectors, no plastic sleeve	0,25 - 1 mm ² , 24 - 16 AWG	0,25 - 1 mm ² , 24 - 16 AWG
2 core with the same cross section, flexible without crimp connectors or with TWIN crimp connectors	0,5 - 1,5 mm ² , 24 - 16 AWG	0,5 - 1,5 mm ² , 24 - 16 AWG
Torque setting with screw terminals	0,6 Nm	0,6 Nm
Dimensions		
Height	94 mm	94 mm
Width	45 mm	45 mm
Depth	135 mm	135 mm
Weight	355 g	355 g

Where standards are undated, the 2014-07 latest editions shall apply.

Safety characteristic data



NOTICE

You must comply with the safety-related characteristic data in order to achieve the required safety level for your plant/machine.

Operating mode	EN ISO 13849-1: 2008 PL	EN ISO 13849-1: 2008 Category	EN 62061 SIL CL	EN 62061 PFH _D [1/h]	EN ISO 13849-1: 2008 T _M [year]
Safety contacts, instantaneous	PL e	Cat. 4	SIL CL 3	2,31E-09	20
Safety contacts, delayed <30 s	PL d	Cat. 3	SIL CL 2	2,64E-09	20
Safety contacts, delayed ≥30 s	PL c	Cat. 1	SIL CL 1	2,87E-09	20

All the units used within a safety function must be considered when calculating the safety characteristic data.



INFORMATION

A safety function's SIL/PL values are **not** identical to the SIL/PL values of the units that are used and may be different. We recommend that you use the PAScal software tool to calculate the safety function's SIL/PL values.

Remove plug-in terminals

Procedure: Insert the screwdriver into the housing recess behind the terminal and lever the terminal out.

Do **not** remove the terminals by pulling the cables!

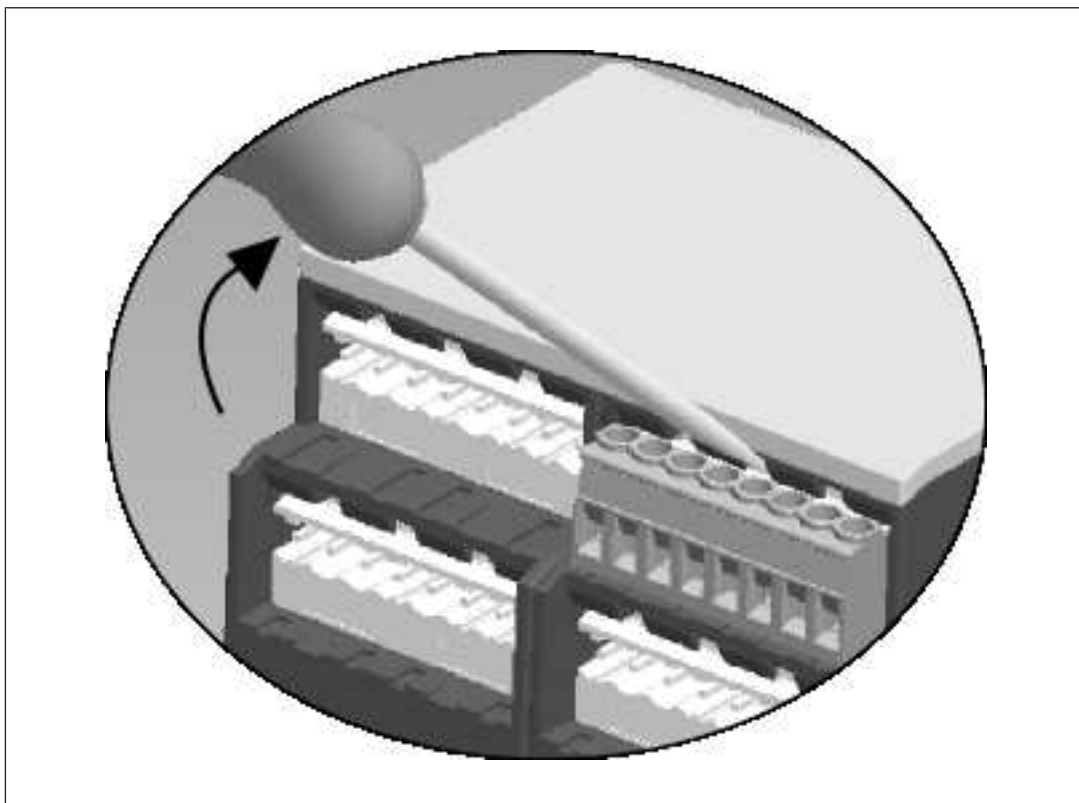

WARNING!

Risk of electrocution!

When voltage is applied, contact with live components could result in serious or even fatal injury from an electric shock.

The plug-in connection terminals should only be connected and disconnected when the voltage is switched off.

Order reference

Product type	Features	Connection type	Order No.
PNOZ p1vp	24 VDC; Delay: up to 30 s selectable	Screw terminals	773 950
PNOZ p1vp	24 VDC; Delay: up to 300 s selectable	Screw terminals	773 951

EC declaration of conformity

This product/these products meet the requirements of the directive 2006/42/EC for machinery of the European Parliament and of the Council. The complete EC Declaration of Conformity is available on the Internet at www.pilz.com/support/downloads.

Representative: Norbert Fröhlich, Pilz GmbH & Co. KG, Felix-Wankel-Str. 2, 73760 Ostfildern, Germany

► Support

Technical support is available from Pilz round the clock.

Americas

Brazil

+55 11 97569-2804

Canada

+1 888-315-PILZ (315-7459)

Mexico

+52 55 5572 1300

USA (toll-free)

+1 877-PILZUSA (745-9872)

Asia

China

+86 21 60880878-216

Japan

+81 45 471-2281

South Korea

+82 31 450 0680

Australia

+61 3 95446300

Europe

Austria

+43 1 7986263-0

Belgium, Luxembourg

+32 9 3217575

France

+33 3 88104000

Germany

+49 711 3409-444

Ireland

+353 21 4804983

Italy

+39 0362 1826711

Scandinavia

+45 74436332

Spain

+34 938497433

Switzerland

+41 62 88979-30

The Netherlands

+31 347 320477

Turkey

+90 216 5775552

United Kingdom

+44 1536 462203

You can reach our international hotline on:

+49 711 3409-444

support@pilz.com

Pilz develops environmentally-friendly products using ecological materials and energy-saving technologies. Offices and production facilities are ecologically designed, environmentally-aware and energy-saving. So Pilz offers sustainability, plus the security of using energy-efficient products and environmentally-friendly solutions.

Energy saving by Pilz



Pilz GmbH & Co. KG
Felix-Wankel-Straße 2
73760 Ostfildern, Germany
Tel.: +49 711 3409-0
Fax: +49 711 3409-133
info@pilz.com
www.pilz.com

PILZ
THE SPIRIT OF SAFETY