



Visualisation; Diagnostics

Easy to Configure

Programming IEC 61131-3

Rapid Installation

## PNOZ pe1p

► Safety relays

**PILZ**  
THE SPIRIT OF SAFETY

This document is a translation of the original document.

All rights to this documentation are reserved by Pilz GmbH & Co. KG. Copies may be made for internal purposes. Suggestions and comments for improving this documentation will be gratefully received.

Source code from third-party manufacturers or open source software has been used for some components. The relevant licence information is available on the Internet on the Pilz homepage.

Pilz®, PIT®, PMI®, PNOZ®, Primo®, PSEN®, PSS®, PVIS®, SafetyBUS p®, SafetyEYE®, SafetyNET p®, the spirit of safety® are registered and protected trademarks of Pilz GmbH & Co. KG in some countries.



SD means Secure Digital

<b>Introduction</b>	<b>4</b>
Validity of documentation	4
Using the documentation	4
Definition of symbols	4
<b>Safety</b>	<b>5</b>
Intended use	5
Safety regulations	5
Safety assessment	5
Use of qualified personnel	6
Warranty and liability	6
Disposal	6
For your safety	6
<b>Unit features</b>	<b>7</b>
<b>Safety features</b>	<b>7</b>
<b>Block diagram/terminal configuration</b>	<b>7</b>
<b>Function Description</b>	<b>7</b>
Operating modes	8
<b>Installation</b>	<b>8</b>
<b>Wiring</b>	<b>9</b>
<b>Preparing for operation</b>	<b>11</b>
<b>Operation</b>	<b>12</b>
Status indicators	12
<b>Faults – Interference</b>	<b>13</b>
<b>Dimensions in mm</b>	<b>13</b>
<b>Technical details</b>	<b>13</b>
Safety characteristic data	15
<b>Remove plug-in terminals</b>	<b>16</b>
<b>Order reference</b>	<b>16</b>
<b>EC declaration of conformity</b>	<b>17</b>

## Introduction

### Validity of documentation

This documentation is valid for the product PNOZ pe1p. It is valid until new documentation is published.

This operating manual explains the function and operation, describes the installation and provides guidelines on how to connect the product.

### Using the documentation

This document is intended for instruction. Only install and commission the product if you have read and understood this document. The document should be retained for future reference.

### Definition of symbols

Information that is particularly important is identified as follows:



#### **DANGER!**

This warning must be heeded! It warns of a hazardous situation that poses an immediate threat of serious injury and death and indicates preventive measures that can be taken.



#### **WARNING!**

This warning must be heeded! It warns of a hazardous situation that could lead to serious injury and death and indicates preventive measures that can be taken.



#### **CAUTION!**

This refers to a hazard that can lead to a less serious or minor injury plus material damage, and also provides information on preventive measures that can be taken.



#### **NOTICE**

This describes a situation in which the product or devices could be damaged and also provides information on preventive measures that can be taken. It also highlights areas within the text that are of particular importance.

**INFORMATION**

This gives advice on applications and provides information on special features.

**Safety****Intended use**

The control module PNOZ pe1p, in conjunction with an expansion module from the PNOZ-power modular safety system, is used for the safety-related interruption of a safety circuit.

It is actuated by

- ▶ PSS range output modules
- ▶ PNOZelog range units
- ▶ PNOZ units with contact outputs.

The control module may only be used with units that evaluate a feedback loop.

The following is deemed improper use in particular:

- ▶ Any component, technical or electrical modification to the product
- ▶ Use of the product outside the areas described in this manual
- ▶ Use of the product outside the technical details (see [Technical details](#)  13)).

**NOTICE**

EMC-compliant electrical installation

The product is designed for use in an industrial environment. The product may cause interference if installed in other environments. If installed in other environments, measures should be taken to comply with the applicable standards and directives for the respective installation site with regard to interference.

**Safety regulations****Safety assessment**

Before using a unit it is necessary to perform a safety assessment in accordance with the Machinery Directive.

Functional safety is guaranteed for the product as a single component. However, this does not guarantee the functional safety of the overall plant/machine. In order to achieve the required safety level for the overall plant/machine, define the safety requirements for the plant/machine and then define how these must be implemented from a technical and organisational standpoint.

### Use of qualified personnel

The products may only be assembled, installed, programmed, commissioned, operated, maintained and decommissioned by competent persons.

A competent person is someone who, because of their training, experience and current professional activity, has the specialist knowledge required to test, assess and operate the work equipment, devices, systems, plant and machinery in accordance with the general standards and guidelines for safety technology.

It is the company's responsibility only to employ personnel who:

- ▶ Are familiar with the basic regulations concerning health and safety / accident prevention
- ▶ Have read and understood the information provided in this description under "Safety"
- ▶ And have a good knowledge of the generic and specialist standards applicable to the specific application.

### Warranty and liability

All claims to warranty and liability will be rendered invalid if

- ▶ The product was used contrary to the purpose for which it is intended
- ▶ Damage can be attributed to not having followed the guidelines in the manual
- ▶ Operating personnel are not suitably qualified
- ▶ Any type of modification has been made (e.g. exchanging components on the PCB boards, soldering work etc.).

### Disposal

- ▶ In safety-related applications, please comply with the mission time  $T_M$  in the safety-related characteristic data.
- ▶ When decommissioning, please comply with local regulations regarding the disposal of electronic devices (e.g. Electrical and Electronic Equipment Act).

### For your safety

The unit meets all the necessary conditions for safe operation. However, please note the following:

- ▶ Note for overvoltage category III: If voltages higher than low voltage (>50 VAC or >120 VDC) are present on the unit, connected control elements and sensors must have a rated insulation voltage of at least 250 V.

## Unit features

- ▶ Actuated via safety contacts or safe semiconductor outputs
- ▶ Expansion module control output via PNOZpower bus
- ▶ LED indicator for:
  - Supply voltage
  - Switch status channel 1
  - Switch status channel 2
  - Error
- ▶ Max. 4 expansion modules can be connected via jumpers
- ▶ Plug-in connection terminals

## Safety features

The safety relay meets the following safety requirements:

- ▶ The circuit is redundant with built-in self-monitoring.
- ▶ The safety function remains effective in the case of a component failure.
- ▶ The correct opening and closing of the safety function relays is tested automatically in each on-off cycle.

## Block diagram/terminal configuration

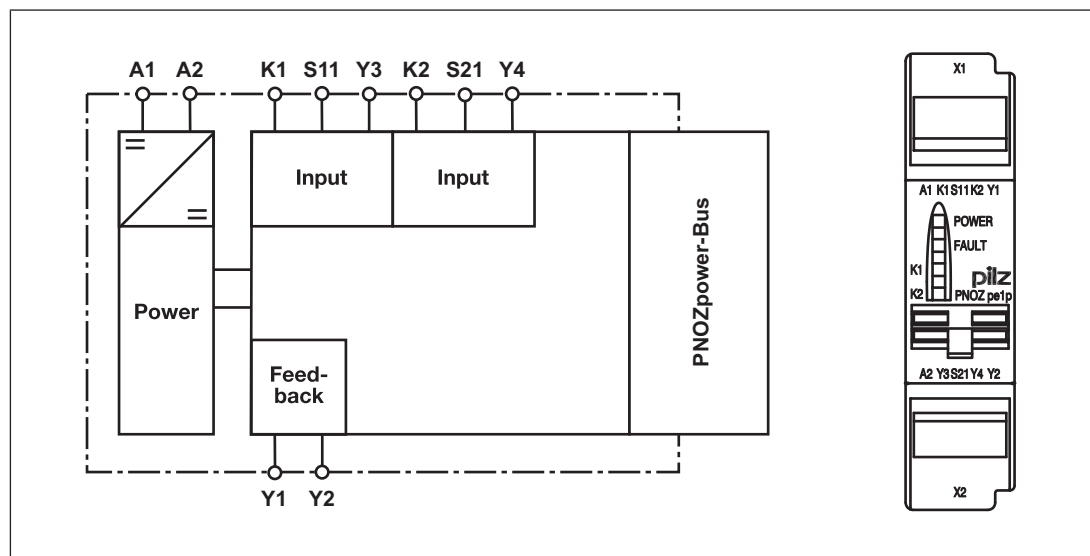

## Function Description

The control module PNOZ pe1p, in conjunction with the expansion modules, is used to expand a safety circuit. It is driven from a master controller (e.g. safe outputs on a PSS). When operating voltage is supplied the "POWER" LED will light.

- ▶ 24 V DC are available at the terminals K1-Y3 and K2-Y4 (e.g. the PSS output has a high signal):
  - The LEDs "CH.1" and "CH.2" are lit.

- At the expansion module control output connected to the PNOZpower bus there is a high signal. The unit is active.
- ▶ 0 V DC are available at the terminals K1-Y3 and K2-Y4 (e.g. the PSS output has a low signal):
  - The LEDs "CH.1" and "CH.2" go out.
  - At the expansion module control output connected to the PNOZpower bus there is a low signal.

**NOTICE**

When controlling an expansion module via the den PNOZpower bus the switch-on delay/delay-on de-energisation of the controlling device (e.g base unit, control module, ...) and the expansion module are added together.

**Operating modes**

- ▶ Single-channel operation: No redundancy in the input circuit, earth faults in the input circuit are detected.
- ▶ Dual-channel operation with detection of shorts across contacts: Redundant input circuit, detects PNOZ pe1p
  - earth faults in the input circuit,
  - shorts across contacts in the input circuit.

**NOTICE**

When semiconductor outputs are used, the detection of shorts across contacts will depend on the master controller.

**Installation**

- ▶ The unit should be installed in a control cabinet with a protection type of at least IP54.
- ▶ Use the notches on the rear of the unit to attach it to a DIN rail.
- ▶ Fit the unit to a horizontal DIN rail. If other mounting positions are used, the switching capability values stated in the technical details cannot be maintained.
- ▶ There are 2 sockets on the rear of the PNOZ pe1p.  
The base unit/control module and the expansion modules are connected using the jumpers supplied.

**NOTICE**

Always connect a terminator to the first and last device.

- ▶ Only use terminators, jumpers and terminals of the modular safety system PNOZpower.



- ▶ Layout:
  - The control module and the expansion modules can be installed in any position on the PNOZpower modular safety system.
- ▶ Maximum hardware:
  - 1 control module
  - 4 expansion modules
  - 1 power supply unit

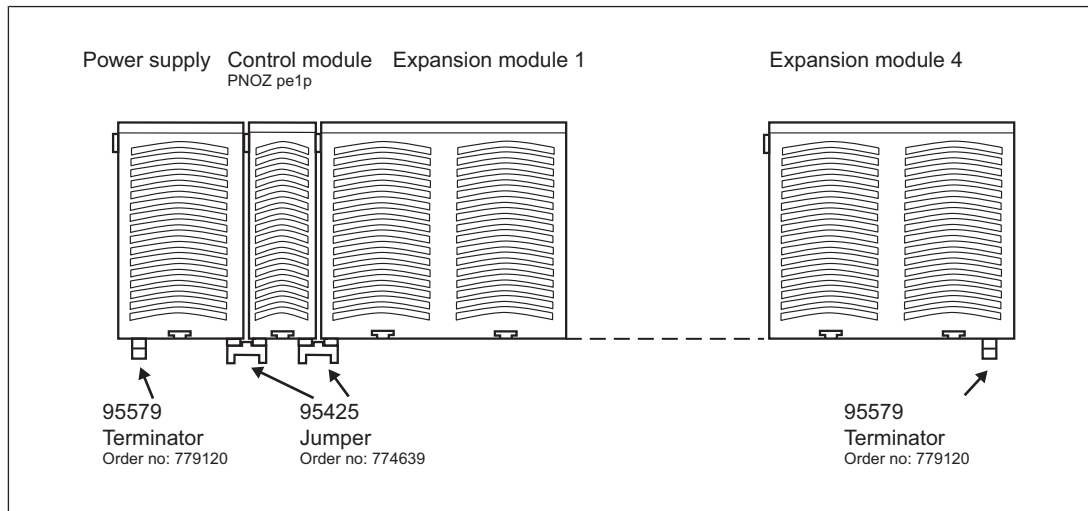

### WARNING!

Risk of electrocution!

When voltage is applied, contact with live components could result in serious or even fatal injury from an electric shock.

The plug-in connection terminals should only be connected and disconnected when the voltage is switched off.

## Wiring

Please note:

- ▶ Information given in the "[Technical details \[13\]](#)" must be followed.
- ▶ Calculation of the max. cable runs  $I_{max}$  in the input circuit:

$$I_{max} = \frac{R_{I_{max}}}{R_l / km}$$

$R_{I_{max}}$  = max. overall cable resistance (see [Technical details \[13\]](#))

$R_l / km$  = cable resistance/km

- ▶ When driven via semiconductor outputs, the maximum cable runs will depend on the master controller.
- ▶ Use copper wire that can withstand 60/75 °C.
- ▶ Ensure the wiring and EMC requirements of IEC 60204-1 are met.

- ▶ The control module and the input circuits must always be supplied by a single power supply.
- ▶ Use the power supply PNOZ pps1p, or an external power supply that complies with the regulations for extra low voltages with safe electrical separation (SELV, PELV) in accordance with VDE 0100, Part 410.

### Preparing for operation

Supply voltage	AC	DC



**NOTICE**

When the PNOZ pps1p power supply unit is used, the unit draws power via the PNOZpower bus. Do not connect an external supply voltage to A1 and A2!

Input circuit	Dual-channel
<b>without</b> detection of shorts across contacts	
<b>with</b> detection of shorts across contacts	

Input circuit	Driven via semiconductor outputs
<b>single-channel</b>	
<b>Dual-channel</b>	

Feedback loop	Driven via semiconductor outputs	Driven via safety contacts
	Terminal <b>Y1</b> : + 24 V DC terminal <b>Y2</b> : connect to a safe input on the master controller	Connect terminals <b>Y1</b> and <b>Y2</b> to the feedback loop on the safety relay.

**Legend**

- ▶ [1]: Digital outputs positive-/negative-switching
- ▶ [2]: Digital outputs positive-switching

## Operation



### NOTICE

The safety function should be checked after initial commissioning and each time the plant/machine is changed. The safety functions may only be checked by qualified personnel.

## Status indicators

LEDs indicate the status and errors during operation:



LED on



### POWER

Supply voltage is present.



### CH.1 IN

Channel 1 input circuit is closed.



### CH.1 IN

Channel 2 input circuit is closed.



### FAULT

Internal error, wiring error or short across contacts



### NOTICE

The electronic fuse and "FAULT" LED only work when terminal S11 is connected. Only then can the PNOZ pe1p detect shorts across contacts. If terminal S11 is not connected, the master controller must monitor for shorts across contacts.

## Faults – Interference

By closing or interrupting the input circuit you can check whether the unit switches on or off correctly.

For safety reasons, the control module cannot be started if the following faults are present:

- ▶ Contact malfunction: As the expansion module is connected to a base unit or a control module, reactivation will not be possible if the contacts have welded after the input circuit has opened.
- ▶ Open circuit, short circuit or earth fault ( e.g. in the input circuit)

## Dimensions in mm

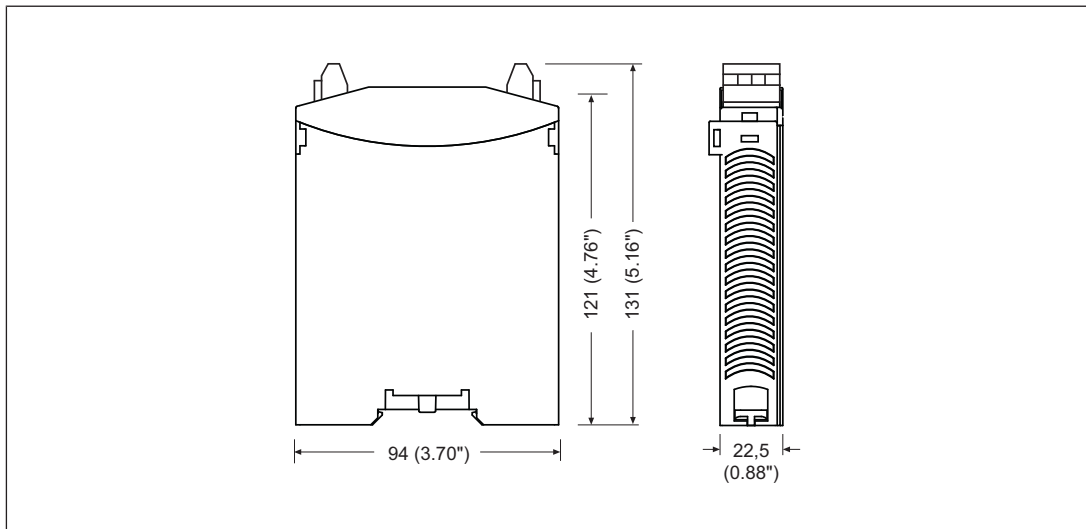

## Technical details

<b>General</b>	
Approvals	CCC, CE, EAC (Eurasian), TÜV, cULus Listed
<b>Electrical data</b>	
Supply voltage	
Voltage	<b>24 V</b>
Kind	<b>DC</b>
Voltage tolerance	<b>-15 %/+10 %</b>
Power consumption	<b>2 W</b>
Residual ripple DC	<b>160 %</b>
Duty cycle	<b>100 %</b>
<b>Inputs</b>	
Number	<b>2</b>
Voltage at	
Input circuit DC	<b>24 V</b>
Start circuit DC	<b>24 V</b>
Feedback loop DC	<b>24 V</b>

<b>Inputs</b>	
Current at	
Input circuit DC	50 mA
Start circuit DC	50 mA
Feedback loop DC	50 mA
Max. overall cable resistance R <sub>lmax</sub>	
Dual-channel with detection of shorts across contacts at UB DC	30 Ohm
<b>Times</b>	
Switch-on delay	
With automatic start after power on max.	10 ms
Delay-on de-energisation	
With E-STOP max.	30 ms
With power failure max.	30 ms
Recovery time at max. switching frequency 1/s	
After E-STOP	30 ms
After power failure	30 ms
Supply interruption before de-energisation	10 ms
Simultaneity, channel 1 and 2 max.	∞
<b>Environmental data</b>	
Climatic suitability	EN 60068-2-78
Ambient temperature	
Temperature range	-10 - 55 °C
Storage temperature	
Temperature range	-40 - 85 °C
Climatic suitability	
Humidity	93 % r. h. at 40 °C
Condensation during operation	Not permitted
EMC	EN 60947-5-1, EN 61000-6-2, EN 61326-3-1
Vibration	
In accordance with the standard	EN 60068-2-6
Frequency	10 - 55 Hz
Amplitude	0,35 mm
Airgap creepage	
In accordance with the standard	EN 60947-1
Overvoltage category	III
Pollution degree	2
Rated insulation voltage	30 V
Rated impulse withstand voltage	0,8 kV
Protection type	
Mounting area (e.g. control cabinet)	IP54
Housing	IP30
Terminals	IP20
<b>Mechanical data</b>	
Mounting position	Horizontal on top hat rail

**Mechanical data**

Material	
Bottom	<b>PPO UL 94 V0</b>
Top	<b>ABS UL 94 V0</b>
Connection type	<b>Screw terminal</b>
Mounting type	<b>plug-in</b>
Conductor cross section with screw terminals	
1 core flexible	<b>0,2 - 2,5 mm<sup>2</sup>, 24 - 12 AWG</b>
2 core with the same cross section, flexible with crimp connectors, no plastic sleeve	<b>0,2 - 1 mm<sup>2</sup>, 24 - 16 AWG</b>
2 core with the same cross section, flexible without crimp connectors or with TWIN crimp connectors	<b>0,2 - 1,5 mm<sup>2</sup>, 24 - 16 AWG</b>
Torque setting with screw terminals	<b>0,25 Nm</b>
Dimensions	
Height	<b>94 mm</b>
Width	<b>22,5 mm</b>
Depth	<b>121 mm</b>
Weight	<b>170 g</b>

Where standards are undated, the 2014-07 latest editions shall apply.

**Safety characteristic data****NOTICE**

You must comply with the safety-related characteristic data in order to achieve the required safety level for your plant/machine.

Operating mode	EN ISO 13849-1: 2008	EN ISO 13849-1: 2008	EN 62061 SIL CL	EN 62061 PFH <sub>D</sub> [1/h]	IEC 61511 SIL	IEC 61511 PFD	EN ISO 13849-1: 2008 T <sub>M</sub> [year]
	PL	Category					
–	<b>PL e</b>	<b>Cat. 4</b>	<b>SIL CL 3</b>	<b>2,31E-09</b>	<b>SIL 3</b>	<b>2,03E-06</b>	<b>20</b>

All the units used within a safety function must be considered when calculating the safety characteristic data.

**INFORMATION**

A safety function's SIL/PL values are **not** identical to the SIL/PL values of the units that are used and may be different. We recommend that you use the PASCAL software tool to calculate the safety function's SIL/PL values.

## Remove plug-in terminals

Procedure: Insert the screwdriver into the housing recess behind the terminal and lever the terminal out.

Do **not** remove the terminals by pulling the cables!

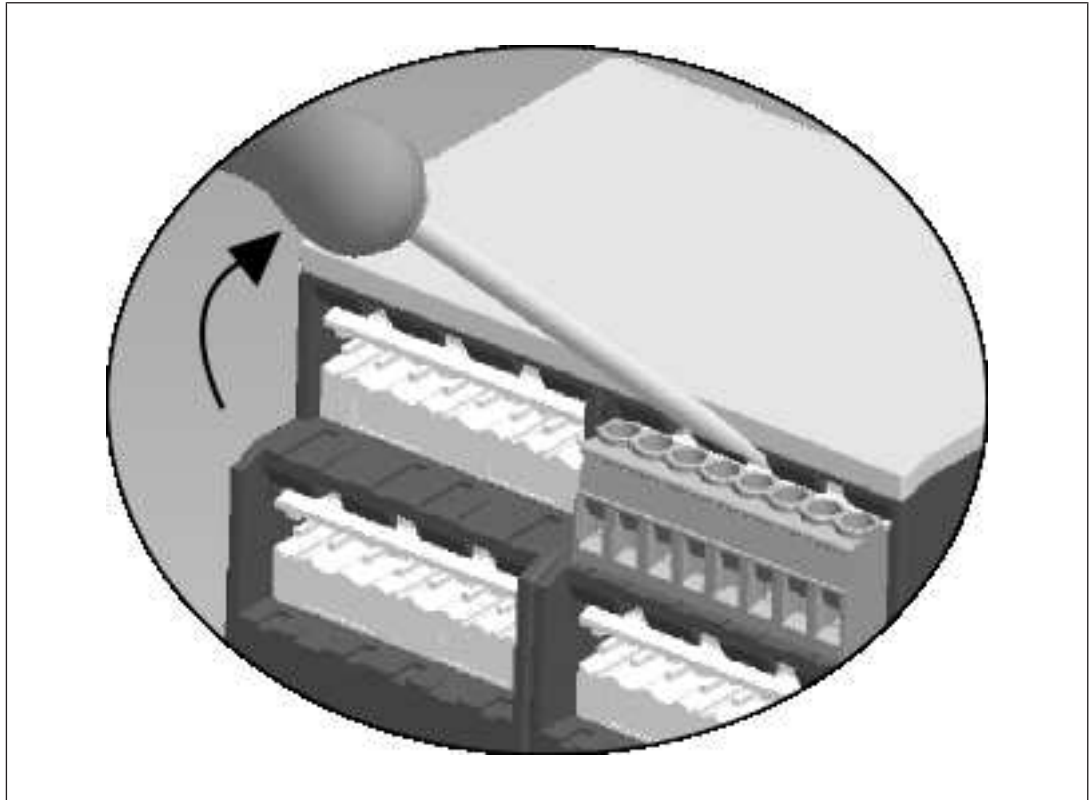

### WARNING!

Risk of electrocution!

When voltage is applied, contact with live components could result in serious or even fatal injury from an electric shock.

The plug-in connection terminals should only be connected and disconnected when the voltage is switched off.

## Order reference

Product type	Features	Connection type	Order No.
PNOZ pe1p	24 VDC	Screw terminals	773 900



**EC declaration of conformity**

This product/these products meet the requirements of the directive 2006/42/EC for machinery of the European Parliament and of the Council. The complete EC Declaration of Conformity is available on the Internet at [www.pilz.com/support/downloads](http://www.pilz.com/support/downloads).

Representative: Norbert Fröhlich, Pilz GmbH & Co. KG, Felix-Wankel-Str. 2, 73760 Ostfildern, Germany

# ► Support

Technical support is available from Pilz round the clock.

## Americas

**Brazil**  
+55 11 97569-2804

**Canada**  
+1 888-315-PILZ (315-7459)

**Mexico**  
+52 55 5572 1300

**USA (toll-free)**  
+1 877-PILZUSA (745-9872)

## Asia

**China**  
+86 21 60880878-216

**Japan**  
+81 45 471-2281

**South Korea**  
+82 31 450 0680

## Australia

+61 3 95446300

## Europe

**Austria**  
+43 1 7986263-0

**Belgium, Luxembourg**  
+32 9 3217575

**France**  
+33 3 88104000

**Germany**  
+49 711 3409-444

**Ireland**  
+353 21 4804983

**Italy**  
+39 0362 1826711

## Scandinavia

+45 74436332

## Spain

+34 938497433

## Switzerland

+41 62 88979-30

## The Netherlands

+31 347 320477

## Turkey

+90 216 5775552

## United Kingdom

+44 1536 462203

## You can reach our international hotline on:

+49 711 3409-444  
support@pilz.com

Pilz develops environmentally-friendly products using ecological materials and energy-saving technologies. Offices and production facilities are ecologically designed, environmentally-aware and energy-saving. So Pilz offers sustainability, plus the security of using energy-efficient products and environmentally-friendly solutions.



Partner of the Engineering Industry Sustainability Initiative

### The 4-fold safety of automation



Pilz GmbH & Co. KG  
Felix-Wankel-Straße 2  
73760 Ostfildern, Germany  
Tel.: +49 711 3409-0  
Fax: +49 711 3409-133  
info@pilz.com  
www.pilz.com

**PILZ**  
THE SPIRIT OF SAFETY