



Visualisation; Diagnostics

Easy to Configure

Programming IEC 61131-3

Rapid Installation

PNOZ pe2p

► Safety relays

PILZ
THE SPIRIT OF SAFETY

This document is the original document.

All rights to this documentation are reserved by Pilz GmbH & Co. KG. Copies may be made for the user's internal purposes. Suggestions and comments for improving this documentation will be gratefully received.

Source code from third-party manufacturers or open source software has been used for some components. The relevant licence information is available on the Internet on the Pilz homepage.

Pilz®, PIT®, PMI®, PNOZ®, Primo®, PSEN®, PSS®, PVIS®, SafetyBUS p®, SafetyEYE®, SafetyNET p®, the spirit of safety® are registered and protected trademarks of Pilz GmbH & Co. KG in some countries.



SD means Secure Digital

Introduction	4
Validity of documentation	4
Using the documentation	4
Definition of symbols	4
Safety	5
Intended use	5
Safety regulations	6
Use of qualified personnel	6
Warranty and liability	6
Disposal	6
Unit features	7
Block diagram/terminal configuration	7
Function Description	7
Operating modes	7
Installation	8
Wiring	9
Preparing for operation	9
Operation	9
Signal statuses of the inputs and outputs	10
Technical details	10
Order reference	11
EC declaration of conformity	11

Introduction

Validity of documentation

This documentation is valid for the product PNOZ pe2p. It is valid until new documentation is published.

This operating manual explains the function and operation, describes the installation and provides guidelines on how to connect the product.

Using the documentation

This document is intended for instruction. Only install and commission the product if you have read and understood this document. The document should be retained for future reference.

Definition of symbols

Information that is particularly important is identified as follows:



DANGER!

This warning must be heeded! It warns of a hazardous situation that poses an immediate threat of serious injury and death and indicates preventive measures that can be taken.



WARNING!

This warning must be heeded! It warns of a hazardous situation that could lead to serious injury and death and indicates preventive measures that can be taken.



CAUTION!

This refers to a hazard that can lead to a less serious or minor injury plus material damage, and also provides information on preventive measures that can be taken.



NOTICE

This describes a situation in which the product or devices could be damaged and also provides information on preventive measures that can be taken. It also highlights areas within the text that are of particular importance.

**INFORMATION**

This gives advice on applications and provides information on special features.

Safety**Intended use**

The PNOZ pe2p bus interface, together with an expansion module of the PNOZpower modular safety system, are used for the safety-related interruption of a safety circuit.

The bus interface consists of a

- ▶ Coupling plug with screw terminals for connecting to a master controller
- ▶ Terminator for terminating the PNOZpower bus

It is actuated by

- ▶ PNOZmulti range units,
- ▶ PSS range output modules,
- ▶ PNOZelog range units.

The bus interface may only be used in conjunction with units that evaluate a feedback loop.

The following is deemed improper use in particular

- ▶ Any component, technical or electrical modification to the product,
- ▶ Use of the product outside the areas described in this manual,
- ▶ Use of the product outside the technical details (see [Technical details](#)  10]).

**NOTICE****EMC-compliant electrical installation**

The product is designed for use in an industrial environment. The product may cause interference if installed in other environments. If installed in other environments, measures should be taken to comply with the applicable standards and directives for the respective installation site with regard to interference.

Safety regulations

Use of qualified personnel

The products may only be assembled, installed, programmed, commissioned, operated, maintained and decommissioned by competent persons.

A competent person is a qualified and knowledgeable person who, because of their training, experience and current professional activity, has the specialist knowledge required. To be able to inspect, assess and operate devices, systems and machines, the person has to be informed of the state of the art and the applicable national, European and international laws, directives and standards.

It is the company's responsibility only to employ personnel who

- ▶ Are familiar with the basic regulations concerning health and safety / accident prevention,
- ▶ Have read and understood the information provided in the section entitled Safety
- ▶ Have a good knowledge of the generic and specialist standards applicable to the specific application.

Warranty and liability

All claims to warranty and liability will be rendered invalid if

- ▶ The product was used contrary to the purpose for which it is intended,
- ▶ Damage can be attributed to not having followed the guidelines in the manual,
- ▶ Operating personnel are not suitably qualified,
- ▶ Any type of modification has been made (e.g. exchanging components on the PCB boards, soldering work etc.).

Disposal

- ▶ When decommissioning, please comply with local regulations regarding the disposal of electronic devices (e.g. Electrical and Electronic Equipment Act).

Unit features

- ▶ Actuated via safety contacts or safe semiconductor outputs
- ▶ Expansion module control output via PNOZpower bus
- ▶ Max. 6 expansion modules can be connected via jumpers
- ▶ Plug-in connection terminals

Block diagram/terminal configuration

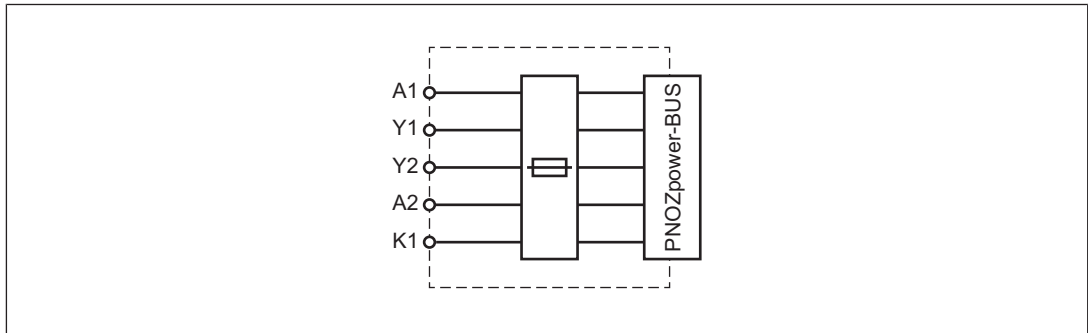

Function Description

The bus interface PNOZ pe2p, in conjunction with the expansion modules, is used to expand a safety circuit. It is driven from a master controller (e.g. safe outputs on a PSS). The unit is ready for operation when when supply voltage is applied and the feedback loop Y1-Y2 is closed

- ▶ 24 V DC are available at the terminal K1 (e.g. the PSS output has a high signal):
 - At the expansion module control output connected to the PNOZpower bus there is a high signal.
- ▶ 0 V DC are available at the terminal K1 (e.g. the PSS output has a low signal):
 - At the expansion module control output connected to the PNOZpower bus there is a low signal.



NOTICE

When controlling an expansion module via the den PNOZpower bus the switch-on delay/delay-on de-energisation of the controlling device and the expansion module are added together.

Operating modes

- ▶ Single-channel operation: no redundancy in the input circuit, earth faults in the start circuit are detected depending on the master controller.

Installation

- ▶ The unit should be installed in a control cabinet with a protection type of at least IP54.
- ▶ Connect the bus interface to the first expansion module via the coupling connector.



NOTICE

Always fit a terminator to the first and last device.

- ▶ Only use terminators, jumpers and terminals of the modular safety system PNOZpower.
- ▶ Layout:
 - The PNOZ pe2p is installed on the left of the first expansion module.
- ▶ Maximum hardware:
 - 1 bus interface
 - 6 expansion modules

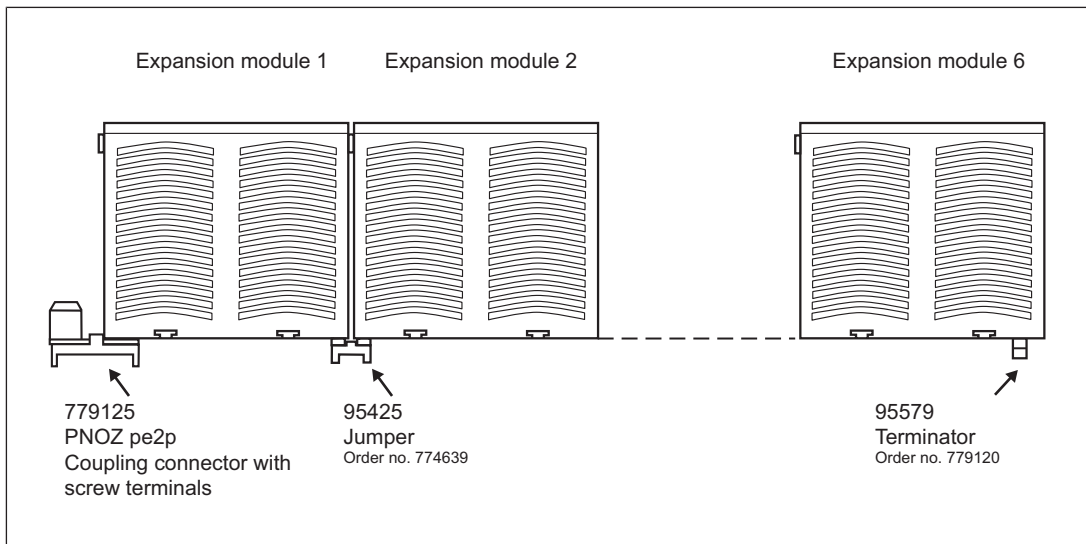

WARNING!

Risk of electrocution!

When voltage is applied, contact with live components could result in serious or even fatal injury from an electric shock.

The plug-in connection terminals should only be connected and disconnected when the voltage is switched off.

Wiring

Please note:

- ▶ Information given in the "[Technical details \[10\]](#)" must be followed.
- ▶ Max. cable runs I_{max} at the input circuit and feedback loop: Short circuits and earth faults are detected by the master controller. The maximum cable runs is therefore dependent on the master controller.
- ▶ Use copper wiring with a temperature stability of 60/75 °C.
- ▶ To prevent EMC interferences (particularly common-mode interferences) the measures described in EN 60204-1 must be executed. This includes the separate routing of cables of the control circuits (input, start and feedback loop) from other cables for energy transmission or the shielding of cables, for example.
- ▶ The bus interface and input circuits of the safety control system/ the safety relay must always be supplied by a single power supply.
- ▶ The power supply must comply with the regulations for extra low voltages with protective electrical separation (SELV, PELV) in accordance with VDE 0100, Part 410.

Preparing for operation

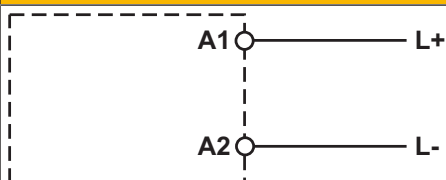
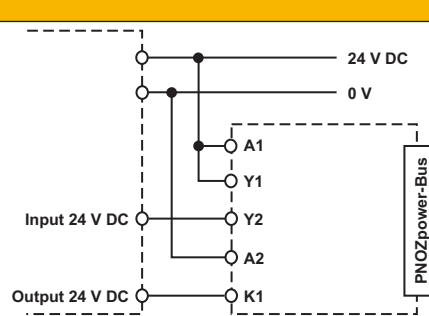
Supply voltage	AC	DC
	/	
Connection		
Control via safety system (PNOZmulti, PSS) or safety relay (PNOZelog)		

Operation



NOTICE

The safety function should be checked after initial commissioning and each time the plant/machine is changed. The safety functions may only be checked by qualified personnel.

Signal statuses of the inputs and outputs

- ▶ K1: PNOZpower input circuit
 - "1" signal (+24 VDC): Expansion modules are actuated
 - "0" signal (0 V): Expansion modules are not actuated
- ▶ Y2: Feedback loop output
 - "1" signal (+24 VDC): Safety contacts of the expansion modules open
 - "0" signal (0 V): Safety contacts of the expansion modules closed

Technical details

General	
Certifications	CE, EAC (Eurasian), TÜV, cULus Listed
Electrical data	
Supply voltage	
Voltage	24 V
Kind	DC
Voltage tolerance	-15 %/+10 %
Residual ripple DC	160 %
Duty cycle	100 %
Inputs	
Number	1
Voltage at	
Input circuit DC	24 V
Feedback loop DC	24 V
Current at	
Input circuit DC	30 mA
Feedback loop DC	1 A
Environmental data	
Climatic suitability	EN 60068-2-78
Ambient temperature	
Temperature range	-10 - 55 °C
Storage temperature	
Temperature range	-25 - 70 °C
Climatic suitability	
Humidity	93 % r. h. at 40 °C
Condensation during operation	Not permitted
EMC	EN 60947-5-1, EN 61000-6-2, EN 61326-3-1
Vibration	
In accordance with the standard	EN 60068-2-6
Frequency	10 - 55 Hz
Amplitude	0,35 mm

Environmental data

Airgap creepage	
In accordance with the standard	EN 60947-1
Overvoltage category	III
Pollution degree	2
Rated insulation voltage	
	30 V
Rated impulse withstand voltage	
	0,8 kV
Protection type	
Housing	IP 00
Terminals	IP20
Mounting area (e.g. control cabinet)	IP54

Mechanical data

Mounting position	horizontally on mounting rail
Connection type	Screw terminal
Mounting type	Fixed
Conductor cross section with screw terminals	
1 core flexible	0,5 - 1,5 mm², 28 - 14 AWG
2 core with the same cross section, flexible with crimp connectors, no plastic sleeve	0,5 - 1,5 mm², 28 - 14 AWG
2 core with the same cross section, flexible without crimp connectors or with TWIN crimp connectors	0,5 - 1,5 mm², 28 - 14 AWG
Torque setting with screw terminals	0,25 Nm
Stripping length with screw terminals	6 mm
Dimensions	
Height	29 mm
Width	23,5 mm
Depth	22,5 mm
Weight	15 g

Where standards are undated, the 2020-07 latest editions shall apply.

Order reference

Product type	Features	Connection type	Order no.
PNOZ pe2p	24 V DC	Screw terminals	779125

EC declaration of conformity

This product/these products meet the requirements of the directive 2006/42/EC for machinery of the European Parliament and of the Council. The complete EC Declaration of Conformity is available on the Internet at www.pilz.com/support/downloads.

Representative: Norbert Fröhlich, Pilz GmbH & Co. KG, Felix-Wankel-Str. 2, 73760 Ostfildern, Germany

► Support

Technical support is available from Pilz round the clock.

Americas

Brazil
+55 11 97569-2804

Canada
+1 888 315 7459

Mexico
+52 55 5572 1300

USA (toll-free)
+1 877-PILZUSA (745-9872)

Asia

China
+86 21 60880878-216

Japan
+81 45 471-2281

South Korea
+82 31 778 3300

Australia

+61 3 95600621

Europe

Austria
+43 1 7986263-0

Belgium, Luxembourg
+32 9 3217570

France
+33 3 88104003

Germany
+49 711 3409-444

Ireland
+353 21 4804983

Italy, Malta
+39 0362 1826711

Scandinavia

+45 74436332

Spain

+34 938497433

Switzerland

+41 62 88979-32

The Netherlands

+31 347 320477

Turkey

+90 216 5775552

United Kingdom

+44 1536 462203

You can reach our international hotline on:

+49 711 3409-444
support@pilz.com

Pilz develops environmentally-friendly products using ecological materials and energy-saving technologies. Offices and production facilities are ecologically designed, environmentally-aware and energy-saving. So Pilz offers sustainability, plus the security of using energy-efficient products and environmentally-friendly solutions.

*Energy
saving by Pilz*



We are represented internationally. Please refer to our homepage www.pilz.com for further details or contact our headquarters.

Headquarters: Pilz GmbH & Co. KG, Felix-Wankel-Straße 2, 73760 Ostfildern, Germany
Telephone: +49 711 3409-0, Telefax: +49 711 3409-133, E-Mail: info@pilz.com, Internet: www.pilz.com

PILZ
THE SPIRIT OF SAFETY

21035-EN-05, 2020-10 Printed in Germany
© Pilz GmbH & Co. KG, 2019

CECE®, CHRE®, CMSE®, InduraNET p®, Leansafe®, Master of Safety®, Master of Security®, PAS4000®, PAScall®, PASconfig®, Pilz®, PTT®, PLID®, PMCPirimo®, PMCPiritego®, PMCTendo®, PMD®, PMJ®, PNOZ®, PRBT®, PRCM®, PRCM®, PSEN®, PSEN®, PSENET p®, SafetyBUS p®, SafetyEYE®, SafetyNET p®, THE SPIRIT OF SAFETY® are registered and protected trademarks of Pilz GmbH & Co. KG in some countries. We would point out that product features may vary from the details stated in this document, depending on the status at the time of publication and the scope of the equipment. We accept no responsibility for the validity, accuracy and entirety of the text and graphics presented in this information. Please contact our Technical Support if you have any questions.