



PNOZ pps1p

PILZ
THE SPIRIT OF SAFETY

- ▶ Safety relays

This document is the original document.

Where unavoidable, for reasons of readability, the masculine form has been selected when formulating this document. We do assure you that all persons are regarded without discrimination and on an equal basis.

All rights to this documentation are reserved by Pilz GmbH & Co. KG. Copies may be made for the user's internal purposes. Suggestions and comments for improving this documentation will be gratefully received.

Pilz®, PIT®, PMI®, PNOZ®, Primo®, PSEN®, PSS®, PVIS®, SafetyBUS p®, SafetyEYE®, SafetyNET p®, the spirit of safety® are registered and protected trademarks of Pilz GmbH & Co. KG in some countries.



SD means Secure Digital

Introduction	4
Validity of documentation	4
Using the documentation	4
Definition of symbols	4
Safety	5
Intended use	5
Safety regulations	5
Use of qualified personnel	5
Warranty and liability	6
Disposal	6
Unit features	6
Block diagram	7
Function Description	7
Installation	7
Wiring	9
Preparing for operation	9
Operation	9
Status indicators	9
Faults – Interference	10
Dimensions in mm	10
Technical details	10
Order reference	12
EC declaration of conformity	12
UKCA-Declaration of Conformity	12

Introduction

Validity of documentation

This documentation is valid for the product PNOZ pps1p. It is valid until new documentation is published.

This operating manual explains the function and operation, describes the installation and provides guidelines on how to connect the product.

Using the documentation

This document is intended for instruction. Only install and commission the product if you have read and understood this document. The document should be retained for future reference.

Definition of symbols

Information that is particularly important is identified as follows:



DANGER!

This warning must be heeded! It warns of a hazardous situation that poses an immediate threat of serious injury and death and indicates preventive measures that can be taken.



WARNING!

This warning must be heeded! It warns of a hazardous situation that could lead to serious injury and death and indicates preventive measures that can be taken.



CAUTION!

This refers to a hazard that can lead to a less serious or minor injury plus material damage, and also provides information on preventive measures that can be taken.



NOTICE

This describes a situation in which the product or devices could be damaged and also provides information on preventive measures that can be taken. It also highlights areas within the text that are of particular importance.



INFORMATION

This gives advice on applications and provides information on special features.

Safety

Intended use

The power supply unit PNOZ pps1p is intended for use in the modular safety system PNOZpower. It supplies base unit and expansion units with the required internal supply voltage.

Improper use

The following is deemed improper use in particular

- ▶ Any component, technical or electrical modification to the product,
- ▶ Use of the product outside the areas described in this operating manual,
- ▶ Use of the product outside the technical details (see [Technical details](#)  10).



NOTICE

EMC-compliant electrical installation

The product is designed for use in an industrial environment. The product may cause interference if installed in other environments. If installed in other environments, measures should be taken to comply with the applicable standards and directives for the respective installation site with regard to interference.

Safety regulations

Use of qualified personnel

The products may only be assembled, installed, programmed, commissioned, operated, maintained and decommissioned by persons who are competent to do so.

A competent person is a qualified and knowledgeable person who, because of their training, experience and current professional activity, has the specialist knowledge required. To be able to inspect, assess and operate devices, systems and machines, the person has to be informed of the state of the art and the applicable national, European and international laws, directives and standards.

It is the company's responsibility only to employ personnel who

- ▶ Are familiar with the basic regulations concerning health and safety / accident prevention,
- ▶ Have read and understood the information provided in the section entitled Safety
- ▶ Have a good knowledge of the generic and specialist standards applicable to the specific application.

Warranty and liability

All claims to warranty and liability will be rendered invalid if

- ▶ The product was used contrary to the purpose for which it is intended,
- ▶ Damage can be attributed to not having followed the guidelines in the manual,
- ▶ Operating personnel are not suitably qualified,
- ▶ Any type of modification has been made (e.g. exchanging components on the PCB boards, soldering work etc.).

Disposal

- ▶ When decommissioning, please comply with local regulations regarding the disposal of electronic devices (e.g. Electrical and Electronic Equipment Act).

Unit features

- ▶ Connection options for:
 - 1 base unit
 - Maximum 4 expansion modules
- ▶ LED indicator for:
 - Supply voltage
 - Output voltage
- ▶ Galvanic isolation
- ▶ Short circuit-proof

Block diagram

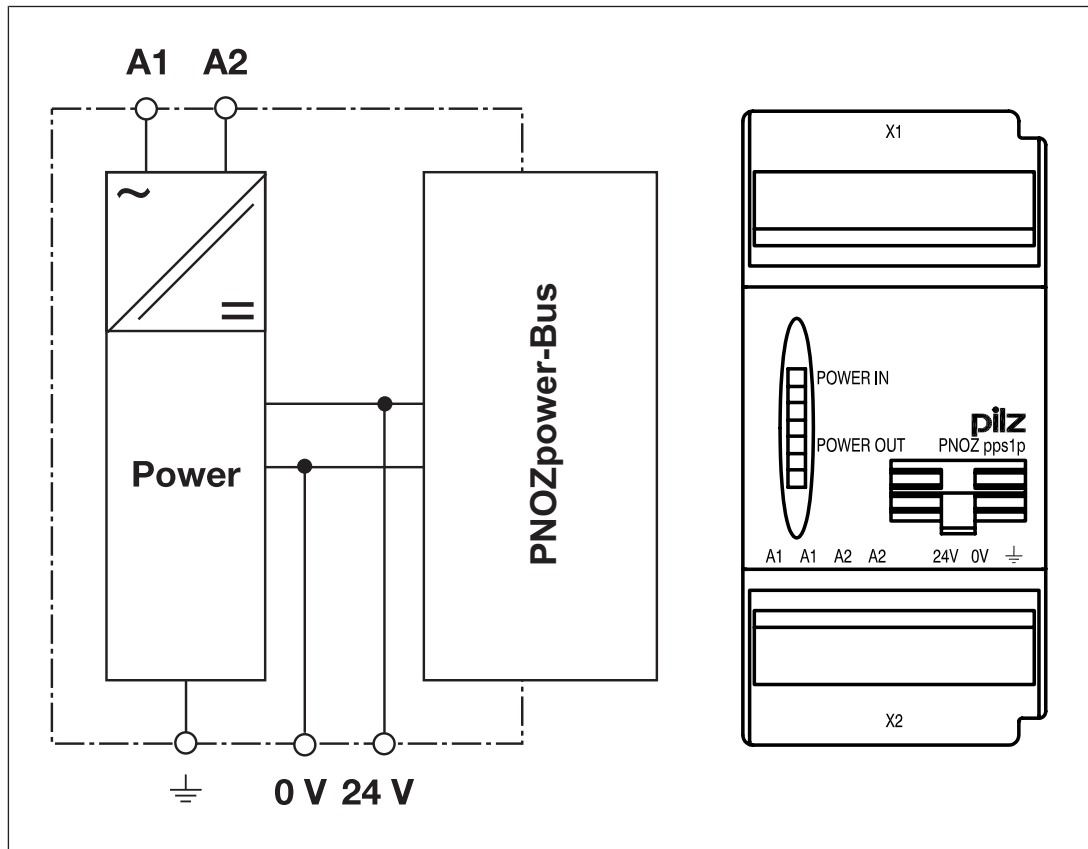

Function Description

The power supply unit PNOZ pps1p supplies the base unit and the expansion modules of the modular safety system PNOZpower with the required supply voltage. When operating voltage is supplied the "POWER IN" LED will light. The "POWER OUT" LED will light when the output voltage is correct. Depending on the plant state it is 19 V DC or 24 V DC. The output voltage is fed to the terminals 0 V and +24 V for measuring purposes.

Installation

- ▶ The unit should be installed in a control cabinet with a protection type of at least IP54.
- ▶ Use the notches on the rear of the unit to attach it to a DIN rail.
- ▶ Fit the unit to a horizontal DIN rail. If other mounting positions are used, the switching capability values stated in the technical details cannot be maintained.
- ▶ There are 2 sockets on the rear of the PNOZ pps1p.
The base unit/control module and the expansion modules are connected using the jumpers supplied.



NOTICE

Always connect a terminator to the first and last device.

- ▶ Only use terminators, jumpers and terminals of the modular safety system PNOZpower.
- ▶ Layout:
 - The power supply unit PNOZ pps1p can be installed in any position on the PNOZ-power modular safety system.
- ▶ Maximum hardware:
 - 1 base unit
 - 4 expansion modules
 - 1 power supply unit

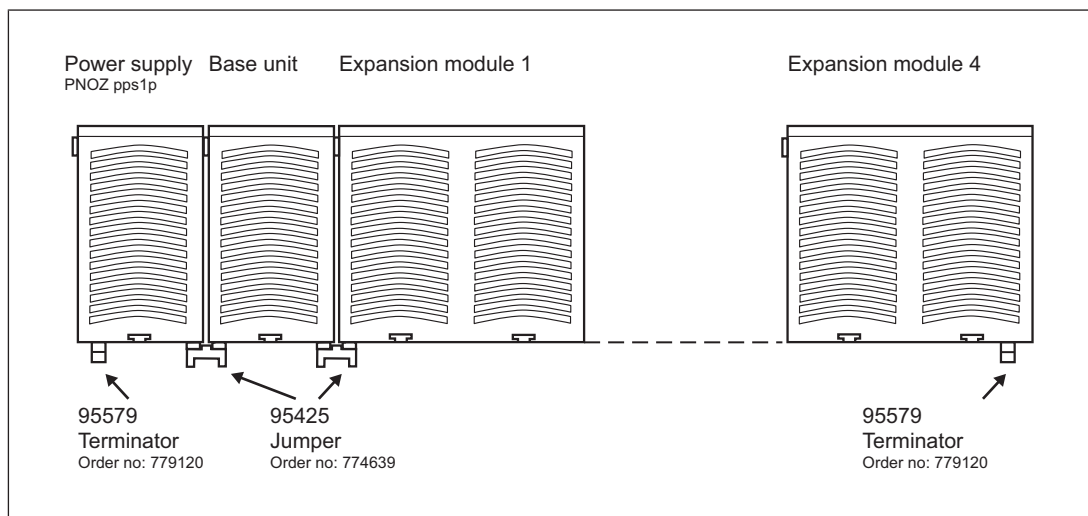

WARNING!

Risk of electrocution!

When voltage is applied, contact with live components could result in serious or even fatal injury from an electric shock.

The plug-in connection terminals should only be connected and disconnected when the voltage is switched off.

Wiring

Please note:

- ▶ Information given in the "[Technical details \[10\]](#)" must be followed.
- ▶ The output voltage can be measured at the terminals 0 V and +24 V.
- ▶ Do **not** connect external user to the terminals 0 V and +24 V!
- ▶ Connect terminal \perp to the protective earth system.
- ▶ When the PNOZ pps1p power supply unit is used, the base unit draws power via the PNOZpower bus. Do not connect an external supply voltage to terminals A1 and A2 of the base unit!
- ▶ Use copper wiring with a temperature stability of 60/75 °C.
- ▶ To prevent EMC interferences (particularly common-mode interferences) the measures described in EN 60204-1 must be executed. This includes the separate routing of cables of the control circuits (input, start and feedback loop) from other cables for energy transmission or the shielding of cables, for example.

Preparing for operation

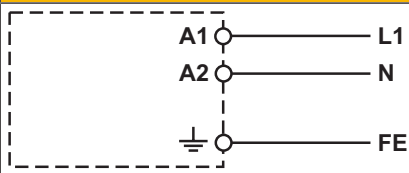
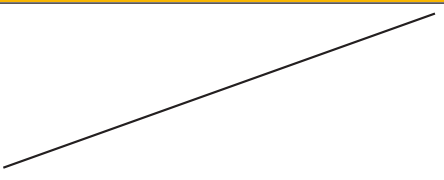
Supply voltage	AC	DC
		

Operation



NOTICE

The safety function should be checked after initial commissioning and each time the plant/machine is changed. The safety functions may only be checked by qualified personnel.

Status indicators

LEDs indicate the status and errors during operation:



LED on



POWER IN

Supply voltage is present.



POWER OUT

Output voltage 19 V DC or 24 V DC is present at PNOZpower bus

Faults – Interference

- ▶ LED "POWER IN" does not light: Supply voltage is missing.
- ▶ LED "POWER OUT" does not light: Short circuit or supply voltage failure.

Dimensions in mm

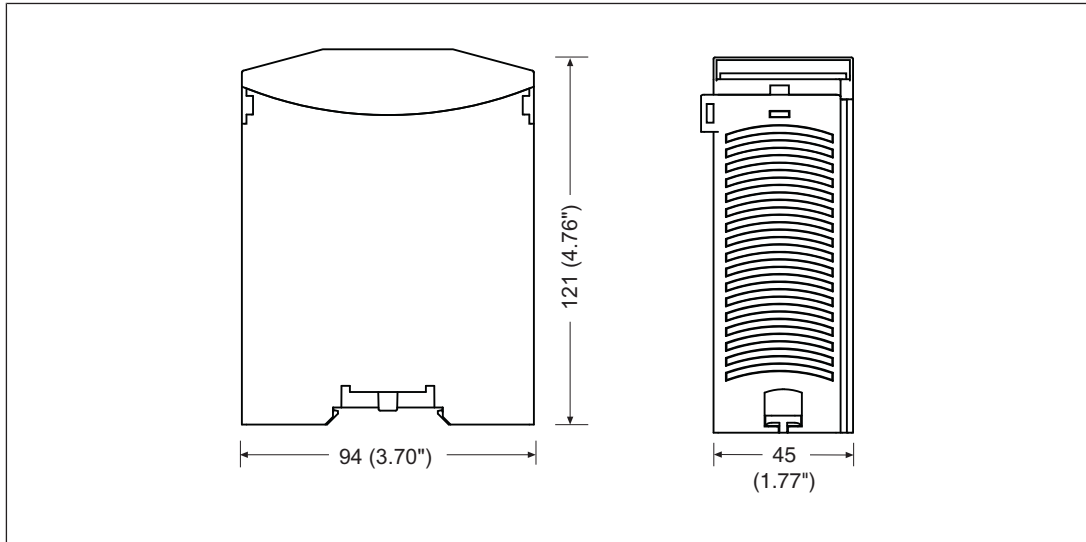

Technical details

General

Certifications **CCC, CE, EAC, TÜV, UKCA, cULus Listed**

Electrical data

Supply voltage

Voltage	100 - 240 V
Kind	AC
Voltage tolerance	-15 %/+10 %
Output of external power supply (AC)	30 VA
Frequency range AC	50 - 60 Hz

Duty cycle **100 %**

Output voltage

Voltage	19 V, 24 V
Kind	DC
Output power	15 W

Times

Supply interruption before de-energisation **20 ms**

Environmental data

Climatic suitability **EN 60068-2-78**

Ambient temperature

Temperature range **-10 - 55 °C**

Storage temperature

Temperature range **-40 - 85 °C**

Environmental data

Climatic suitability	
Humidity	93 % r. h. at 40 °C
Condensation during operation	Not permitted
EMC	EN 60947-5-1, EN 61000-6-2, EN 61000-6-3
Vibration	
In accordance with the standard	EN 60068-2-6
Frequency	10 - 55 Hz
Amplitude	0,35 mm
Airgap creepage	
In accordance with the standard	EN 60947-1
Overvoltage category	III
Pollution degree	2
Rated insulation voltage	250 V
Rated impulse withstand voltage	4 kV
Protection type	
Housing	IP40
Terminals	IP20
Mounting area (e.g. control cabinet)	IP54

Mechanical data

Mounting position	horizontally on mounting rail
Material	
Bottom	PPO UL 94 V1
Front	ABS UL 94 V0
Top	ABS UL 94 V0
Connection type	Screw terminal
Mounting type	plug-in
Conductor cross section with screw terminals	
1 core flexible	0,2 - 2,5 mm², 24 - 14 AWG
2 core with the same cross section, flexible with crimp connectors, no plastic sleeve	0,25 - 1 mm², 24 - 14 AWG
2 core with the same cross section, flexible without crimp connectors or with TWIN crimp connectors	0,5 - 1,5 mm²,
Torque setting with screw terminals	0,5 Nm
Stripping length with screw terminals	8 mm
Dimensions	
Height	94 mm
Width	45 mm
Depth	121 mm
Weight	285 g

Where standards are undated, the 2020-07 latest editions shall apply.

Order reference

Product type	Features	Connection type	Order no.
PNOZ pps1p	Supply voltage: 100-240 V AC Output voltage: 19 V DC; 24 V DC	Screw terminals	773200

EC declaration of conformity

This product/these products meet the requirements of the directive 2006/42/EC for machinery of the European Parliament and of the Council. The complete EC Declaration of Conformity is available on the Internet at www.pilz.com/support/downloads.

Representative: Norbert Fröhlich, Pilz GmbH & Co. KG, Felix-Wankel-Str. 2, 73760 Ostfildern, Germany

UKCA-Declaration of Conformity

This product(s) complies with following UK legislation: Supply of Machinery (Safety) Regulation 2008.

The complete UKCA Declaration of Conformity is available on the Internet at www.pilz.com/support/downloads.

Representative: Pilz Automation Technology, Pilz House, Little Colliers Field, Corby, Northamptonshire, NN18 8TJ United Kingdom, eMail: mail@pilz.co.uk

