



Visualisation; Diagnostics

Easy to Configure

Programming IEC 61131-3

Rapid Installation

PSEN ix2 F4 code

► PSEN sensor technology

PILZ
THE SPIRIT OF SAFETY

This document is a translation of the original document.

All rights to this documentation are reserved by Pilz GmbH & Co. KG. Copies may be made for internal purposes. Suggestions and comments for improving this documentation will be gratefully received.

Source code from third-party manufacturers or open source software has been used for some components. The relevant licence information is available on the Internet on the Pilz homepage.

Pilz®, PIT®, PMI®, PNOZ®, Primo®, PSEN®, PSS®, PVIS®, SafetyBUS p®, SafetyEYE®, SafetyNET p®, the spirit of safety® are registered and protected trademarks of Pilz GmbH & Co. KG in some countries.



SD means Secure Digital

Introduction	4
Validity of documentation	4
Using the documentation	4
Definition of symbols	4
Overview	5
Unit features	5
Range	5
Front view	6
Safety	7
Intended use	7
Safety regulations	7
Additional documents that apply	7
Use of qualified personnel	7
Warranty and liability	8
Disposal	8
Function description	8
Installation	9
Wiring	10
General wiring guidelines	10
Pin assignment	10
Connection to evaluation devices	12
General	12
Independent circuit	12
Series connection of the interface	14
Dimensions	16
Technical details	16
Order reference	17
System	17
Accessories	17

Introduction

Validity of documentation

This documentation is valid for the product PSEN ix2 F4 code. It is valid until new documentation is published.

This operating manual explains the function and operation, describes the installation and provides guidelines on how to connect the product.

Using the documentation

This document is intended for instruction. Only install and commission the product if you have read and understood this document. The document should be retained for future reference.

Definition of symbols

Information that is particularly important is identified as follows:



DANGER!

This warning must be heeded! It warns of a hazardous situation that poses an immediate threat of serious injury and death and indicates preventive measures that can be taken.



WARNING!

This warning must be heeded! It warns of a hazardous situation that could lead to serious injury and death and indicates preventive measures that can be taken.



CAUTION!

This refers to a hazard that can lead to a less serious or minor injury plus material damage, and also provides information on preventive measures that can be taken.



NOTICE

This describes a situation in which the product or devices could be damaged and also provides information on preventive measures that can be taken. It also highlights areas within the text that are of particular importance.

**INFORMATION**

This gives advice on applications and provides information on special features.

Overview**Unit features**

The PSEN ix2 F4 code is an interface for connecting series-connectable PSENcode, PSENSlock, PSENini sensors to an evaluation device.

Decentralised passive junction for connecting sensors to a Pilz control system.

- ▶ Max. 4 sensors per PSEN ix2 F4 code can be connected
- ▶ Max. 5 PSEN ix2 F4 code with max. 16 subscribers can be connected in series
- ▶ Forwarding of diagnostic information from the connected sensors.

Range

- ▶ Interface PSEN ix2 F4 code with three bridges inserted

Front view

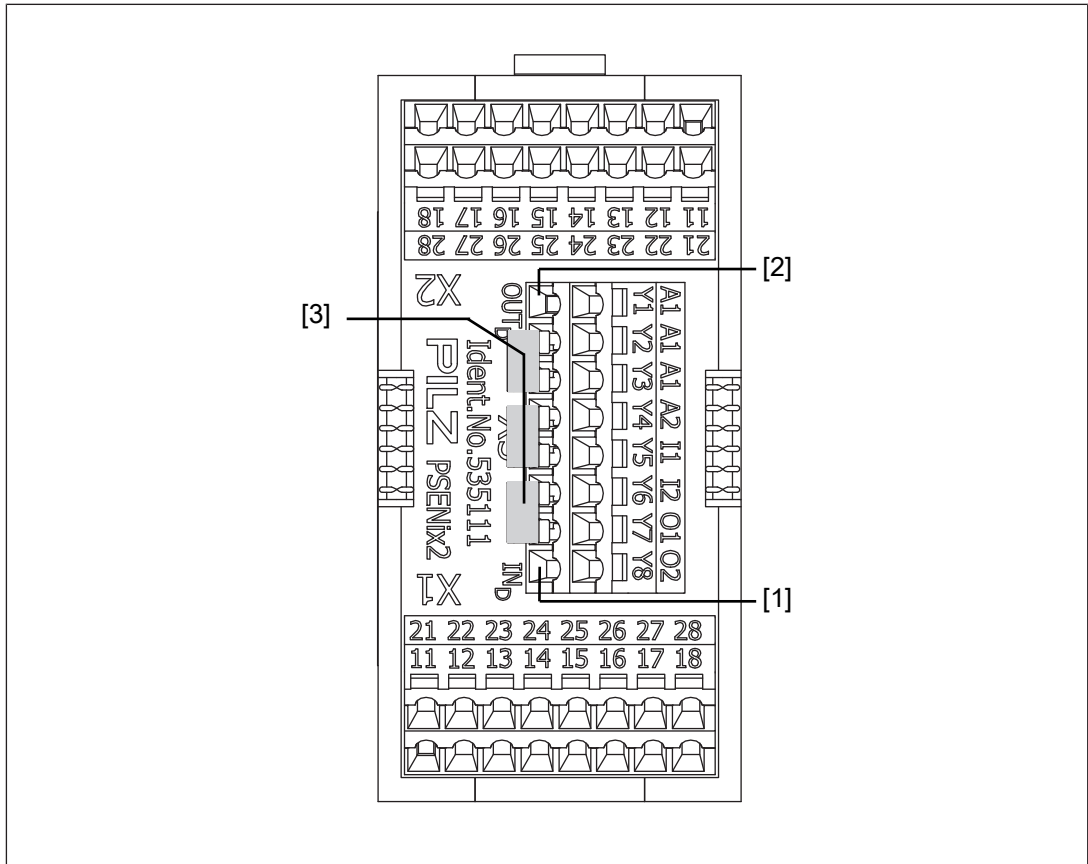

Legend

- X1 ▶ 11-18: Terminals for connecting sensor 1
 - ▶ 21-28: Terminals for connecting sensor 2
- X2 ▶ 11-18: Terminals for connecting sensor 3
 - ▶ 21-28: Terminals for connecting sensor 4
- X3 ▶ A1-O2: Terminals for
 - Supply voltage
 - Inputs channel 1 and 2
 - Outputs channel 1 and 2
- ▶ Y1-Y8: Terminals for communication, data inputs and outputs from the sensors PSEN 1-4

[1] Terminal Y8: Diagnostic input IN_D for sensor 1

[2] Terminal Y1: Diagnostic output OUT_D from sensor 4

[3] Terminals Y2+Y3, Y4+Y5, Y6+Y7 are bridged when delivered

Safety

Intended use

The PSEN ix2 F4 code is an interface for connecting series-connectable PSENcode, PSENslock, PSENini sensors to an evaluation device.

- ▶ Connection to Safety Device Diagnostics (SDD) and forwarding of diagnostic information from the connected sensors to a fieldbus module. Further information is provided in the document entitled "System Description Safety Device Diagnostics".
- ▶ Series connection of PSEN sensors and connection to an evaluation device

A max. of 4 PSEN sensors can be connected to a PSEN ix2 F4 code. All sensors must be 8-pin, with 2 safety inputs each.

The following is deemed improper use in particular:

- ▶ Any component, technical or electrical modification to the product
- ▶ Use of the product outside the areas described in this manual
- ▶ Use of the product outside the technical details (see [Technical details](#) [ 16]).



NOTICE

EMC-compliant electrical installation

The product is designed for use in an industrial environment. The product may cause interference if installed in other environments. If installed in other environments, measures should be taken to comply with the applicable standards and directives for the respective installation site with regard to interference.

Safety regulations

Additional documents that apply

Please read and take note of the following documents:

- ▶ Operating manual for the relevant Pilz safety device
- ▶ Operating manual for the fieldbus module, for example SDD ES ETH or SDD ES PROFIBUS
- ▶ System description "Safety Device Diagnostics"

You will need to be conversant with the information in these documents in order to fully understand this manual.

Use of qualified personnel

The products may only be assembled, installed, programmed, commissioned, operated, maintained and decommissioned by competent persons.

A competent person is someone who, because of their training, experience and current professional activity, has the specialist knowledge required to test, assess and operate the work equipment, devices, systems, plant and machinery in accordance with the general standards and guidelines for safety technology.

It is the company's responsibility only to employ personnel who:

- ▶ Are familiar with the basic regulations concerning health and safety / accident prevention
- ▶ Have read and understood the information provided in this description under "Safety"
- ▶ And have a good knowledge of the generic and specialist standards applicable to the specific application.

Warranty and liability

All claims to warranty and liability will be rendered invalid if

- ▶ The product was used contrary to the purpose for which it is intended
- ▶ Damage can be attributed to not having followed the guidelines in the manual
- ▶ Operating personnel are not suitably qualified
- ▶ Any type of modification has been made (e.g. exchanging components on the PCB boards, soldering work etc.).

Disposal

- ▶ When decommissioning, please comply with local regulations regarding the disposal of electronic devices (e.g. Electrical and Electronic Equipment Act).

Function description

With the help of the PSEN ix2 F4 code, Pilz sensors can be connected in series and connected to a fieldbus module for evaluation of diagnostics data. PSEN ix2 F4 code can also be connected in series.

- ▶ Max. 4 Pilz sensors can be connected to a PSEN ix2 F4 code.
- ▶ Max. 5 PSEN ix2 F4 code (= max. 16 subscribers) can be connected to a fieldbus module.

Internal wiring diagram

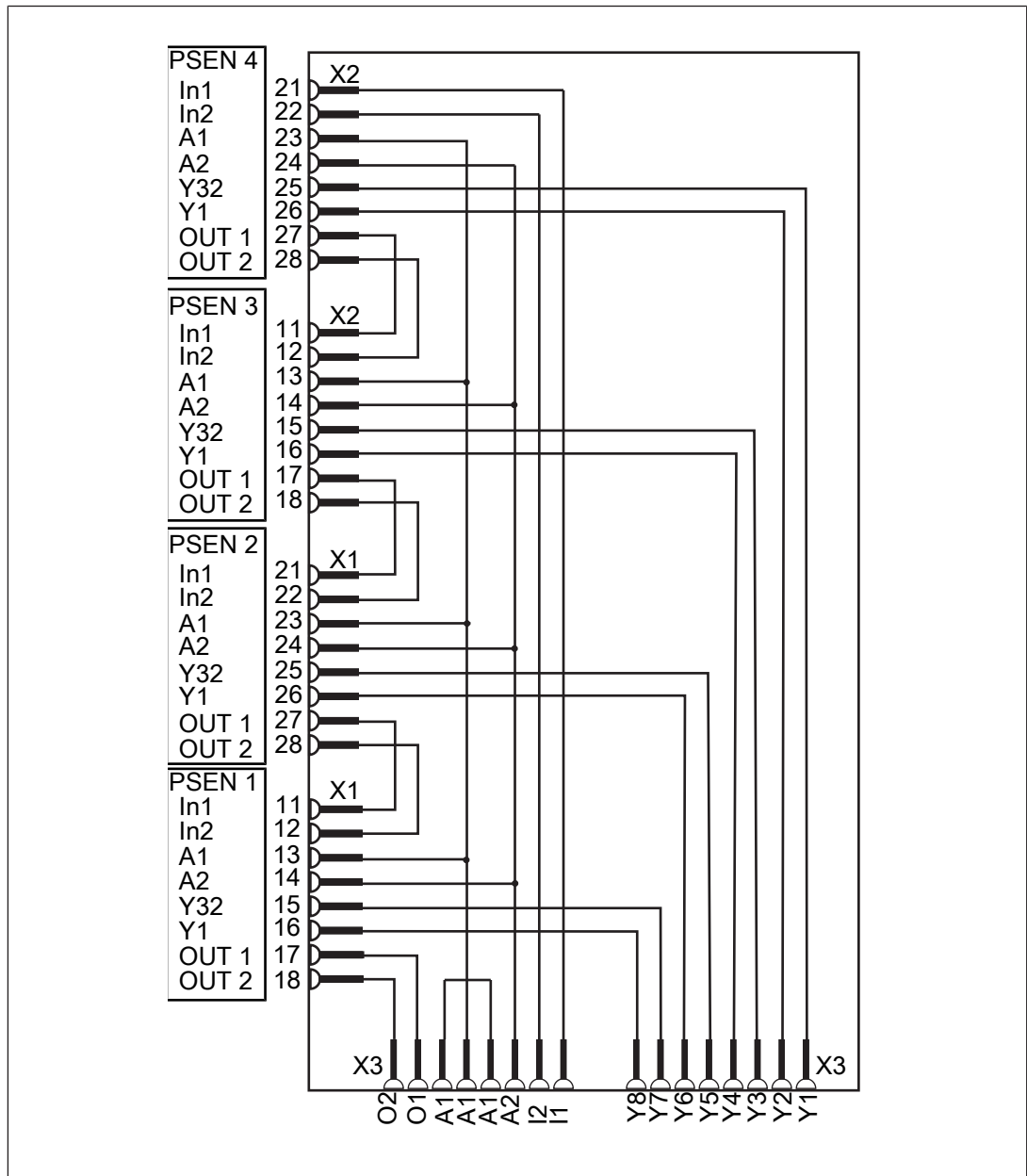

The diagnostic data from the sensors connected to the PSEN ix2 F4 code can be read and entered at terminal block X3.

Installation

- ▶ The unit should be installed in a lockable control cabinet with a protection type of at least IP54.
- ▶ Use the notch on the rear of the unit to attach it to a DIN rail.
- ▶ When installed on a vertical mounting rail (35 mm): Secure the unit by using a fixing element (e.g. retaining bracket or end angle).
- ▶ Circumvention of the safety switch in a reasonably foreseeable manner must be prevented.

Wiring

General wiring guidelines

Please note:

- ▶ Information given in the [Technical details \[16\]](#) must be followed.
- ▶ The device must always be supplied by a single power supply. The power supply must meet the regulations for extra low voltages with protective separation.
- ▶ Where safety-related applications are concerned, it is essential that short circuits and open circuits are unable to cause a hazardous condition within a plant. The way in which this is done will depend on the degree of hazard from the plant section, the switching frequency of the sensors and the level of safety of the sensors and actuators.

Pin assignment

Terminal block X1

Terminal	Device	Function	Cable colour
11	PSEN 1	Input channel 1 of sensor	Pink
12		Input channel 2 of sensor	White
13		24 VDC	Brown
14		0 VDC	Blue
15		Signal output/diagnostic output Y32 of sensor	Grey
16		Signal input/diagnostic input Y1 of sensor	Red
17		Output channel 1 of sensor	Green
18		Output channel 2 of sensor	Yellow
21	PSEN 2	Input channel 1 of sensor	Pink
22		Input channel 2 of sensor	White
23		24 VDC	Brown
24		0 VDC	Blue
25		Signal output/diagnostic output Y32 of sensor	Grey
26		Signal input/diagnostic input Y1 of sensor	Red
27		Output channel 1 of sensor	Green
28		Output channel 2 of sensor	Yellow

Terminal block X2

Terminal	Device	Function	Cable colour
11	PSEN 3	Input channel 1 of sensor	Pink
12		Input channel 2 of sensor	White
13		24 VDC	Brown
14		0 VDC	Blue
15		Signal output/diagnostic output Y32 of sensor	Grey
16		Signal input/diagnostic input Y1 of sensor	Red
17		Output channel 1 of sensor	Green
18		Output channel 2 of sensor	Yellow
21	PSEN 4	Input channel 1 of sensor	Pink
22		Input channel 2 of sensor	White
23		24 VDC	Brown
24		0 VDC	Blue
25		Signal output/diagnostic output Y32 of sensor	Grey
26		Signal input/diagnostic input Y1 of sensor	Red
27		Output channel 1 of sensor	Green
28		Output channel 2 of sensor	Yellow

Terminal block X3

Terminal	Device	Function	Cable colour
Y1	Fieldbus module	Status of signal output/diagnostic output of PSEN 4	Grey
Y2		Status of signal input/diagnostic input of PSEN 4	
Y3		Status of signal output/diagnostic output of PSEN 3	
Y4		Status of signal input/diagnostic input of PSEN 3	
Y5		Status of signal output/diagnostic output of PSEN 2	
Y6		Status of signal input/diagnostic input of PSEN 2	
Y7		Status of signal output/diagnostic output of PSEN 1	
Y8		Status of signal input/diagnostic input of PSEN 1	Red
A1	Power supply	Supply voltage + 24 V	Brown
A1			
A1			

Terminal	Device	Function	Cable colour
A2	Power supply	0 VDC	Blue
I1	PSEN n	Input channel 1 for last sensor PSEN n	Pink
I2		Input channel 2 for last sensor PSEN n	White
O1	Evaluation device	Output channel 1 for evaluation device	Green
O2		Output channel 2 for evaluation device	Yellow

Connection to evaluation devices

General



NOTICE

Each time the cabling is changed during commissioning, trigger the safety function of each sensor in the safety chain and check that the safety outputs on the evaluation device react correctly.

Independent circuit

Please note:

- ▶ When connected to the PSEN ix2 F4 code, the sequence of the sensors must be maintained.
 - PSEN 1: Terminal block X1, terminals 11-18
 - PSEN 2: Terminal block X1, terminals 21-28
 - PSEN 3: Terminal block X2, terminals 11-18
 - PSEN 4: Terminal block X2, terminals 21-28

Connecting fewer than four sensors

- ▶ If fewer than four sensors are connected to a PSEN ix2 F4 code, the free sensor terminals on terminal blocks X1 and X2 must be bridged.
 - Terminal blocks X1 and X2
 - Bridges between terminals 11 and 17, 12 and 18 and 15 and 16.
 - Bridges between terminals 21 and 27, 22 and 28 and 25 and 26.

The terminals on terminal blocks X1 and X2 must be bridged for each unconnected sensor (see diagram).

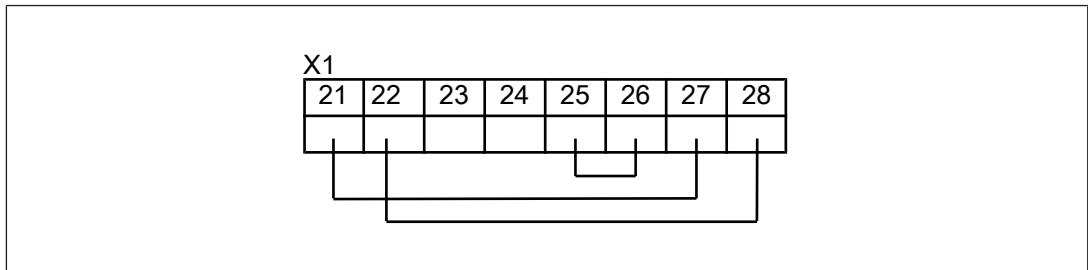
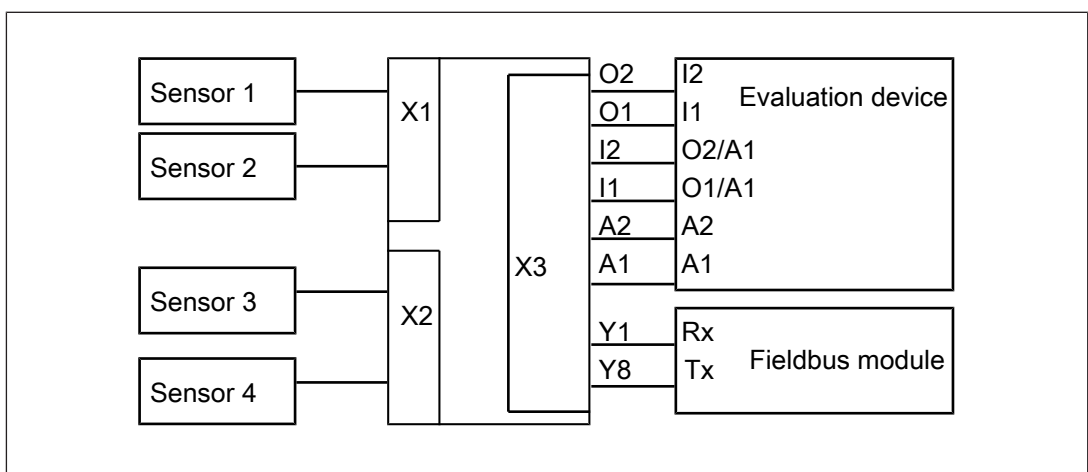
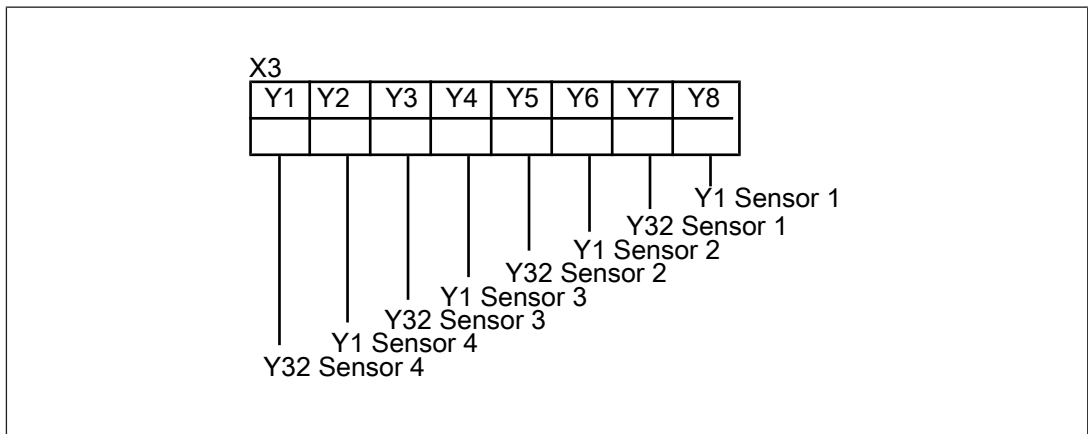

Fig.: Terminal block X1 with three bridges for an unconnected sensor

Connection without fieldbus module

- ▶ If the PSEN ix2 F4 code will not be connected to a fieldbus module, the bridges that are inserted on terminals X3 Y2 – X3 Y7 when the PSEN ix2 F4 code is delivered must all be removed. The respective states of the sensors' signal input/diagnostic input Y1 and signal output/diagnostic output Y32 are output at these terminals. To evaluate the data, the relevant control system must be connected to the terminals (see diagram).
 - Terminals Y1, Y3, Y5, Y7 for the sensors' signal output/diagnostic output Y32
 - Terminals Y2, Y4, Y6, Y8 for the sensors' signal input/diagnostic input Y1



Series connection of the interface

Please note:

- ▶ Max. 5 PSEN ix2 F4 code can be connected in series.
- ▶ Max. 16 sensors can be connected to a fieldbus module.
- ▶ Only three sensors can be connected to the first PSEN ix2 F4 code devices. 4 sensors can be connected to the final PSEN ix2 F4 code device.



NOTICE

Each time the cabling is changed during commissioning, trigger the safety function of each sensor in the safety chain and check that the safety outputs on the evaluation device react correctly.



CAUTION!

Extension of delay-on de-energisation

When several (n) devices are connected in series, the delay-on de-energisation time adds with the number of interconnected safety switches.

The max. delay-on de-energisation is composed of
max. delay-on de-energisation actuator
+ (n-1) x max. delay-on de-energisation of the inputs
+ delay-on de-energisation of the evaluation device

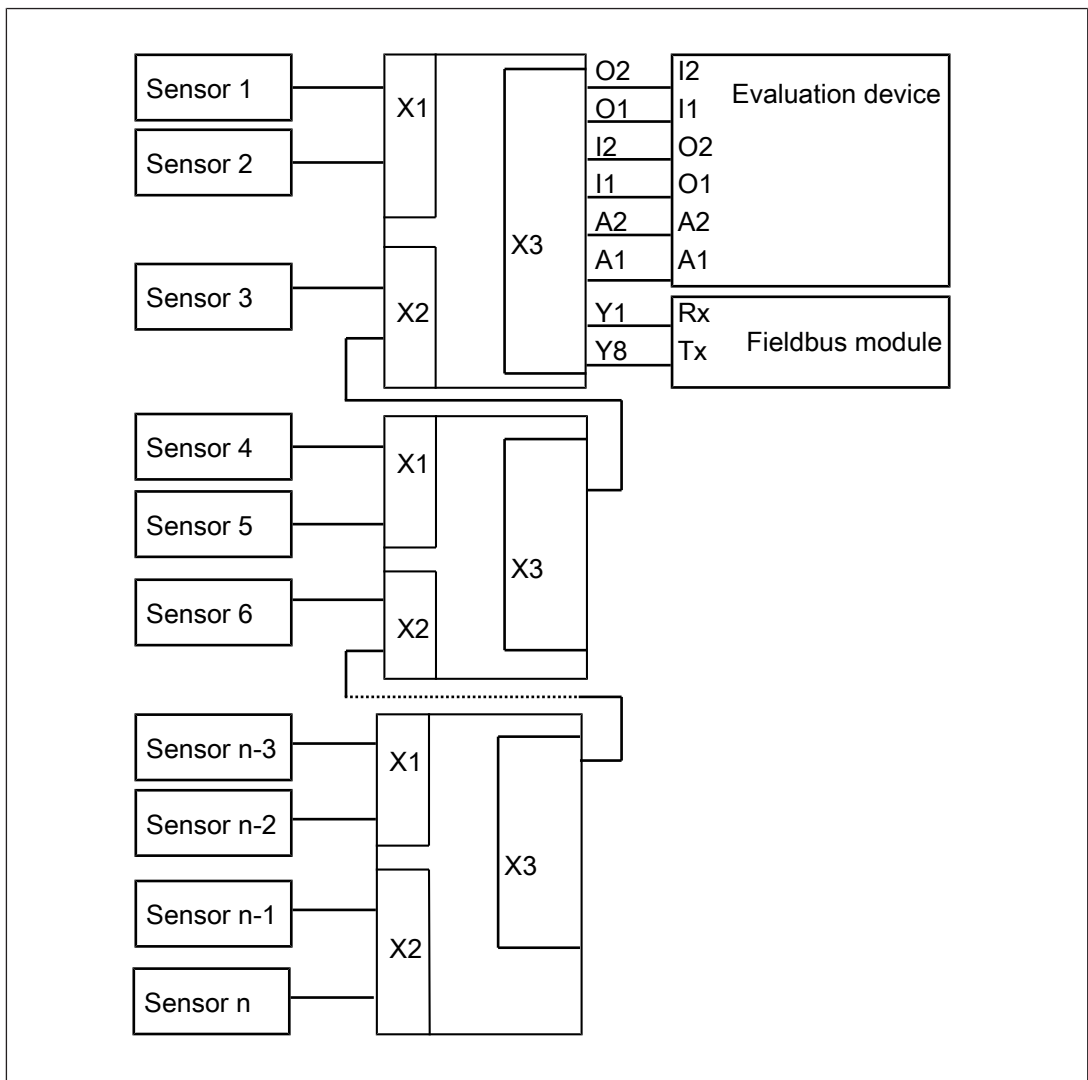

Dimensions

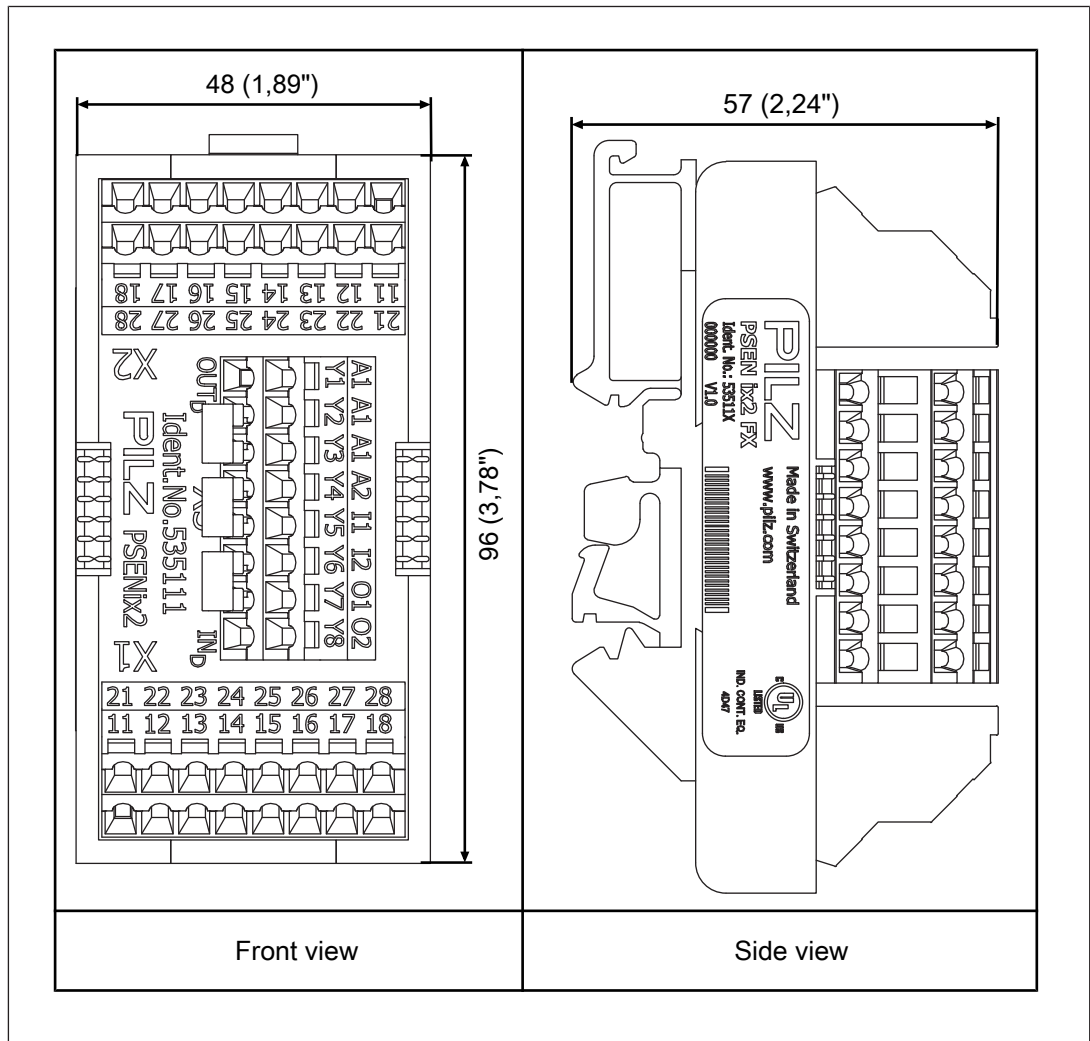

Technical details

General	
Approvals	UL/cUL
Electrical data	
Internal resistance	0 Ohm
Rated voltage	
Voltage UB	30 V
Kind	DC
Environmental data	
Ambient temperature	
Temperature range	-10 - 55 °C
Storage temperature	
Temperature range	-25 - 70 °C

Environmental data	
Protection type	
Mounting area (e.g. control cabinet)	IP54
Terminals	IP20
Mechanical data	
Connection type	Spring-loaded terminal
Dimensions	
Height	57 mm
Width	96 mm
Depth	48 mm
Weight	112 g

Order reference

System

Product type	Features	Connection type	Order No.
PSEN ix2 F4 code	Interface for connecting max. 4 PSEN safety sensors	Spring-loaded terminal	535 111

Accessories

Product type	Connection 1	Connection 2	Length	Order No.
PSEN cable M8-8sf	Straight, M8, 8-pin, socket	Open cable	2 m	533 150
			5 m	533 151
			10 m	533 152
			20 m	533 153
			30 m	533 154
PSEN ma Cable M8-8af	Angled, M8, 8-pin, socket	Open cable	10 m	533 162
PSEN cable M12-8sf	Straight, M12, 8-pin, socket	Open cable	3 m	540 319
			5 m	540 320
			10 m	540 321
			20 m	540 333
			30 m	540 326
PSEN cable M12-8af	Angled, M12, 8-pin, socket	Open cable	3 m	540 322
			5 m	540 323
			10 m	540 324
			30 m	540 325

► Support

Technical support is available from Pilz round the clock.

Americas

Brazil
+55 11 97569-2804

Canada
+1 888-315-PILZ (315-7459)

Mexico
+52 55 5572 1300

USA (toll-free)
+1 877-PILZUSA (745-9872)

Asia

China
+86 21 60880878-216

Japan
+81 45 471-2281

South Korea
+82 31 450 0680

Australia

+61 3 95446300

Europe

Austria
+43 1 7986263-0

Belgium, Luxembourg
+32 9 3217575

France
+33 3 88104000

Germany
+49 711 3409-444

Ireland
+353 21 4804983

Italy
+39 0362 1826711

Scandinavia

+45 74436332

Spain

+34 938497433

Switzerland

+41 62 88979-30

The Netherlands

+31 347 320477

Turkey

+90 216 5775552

United Kingdom

+44 1536 462203

You can reach our international hotline on:

+49 711 3409-444
support@pilz.com

Pilz develops environmentally-friendly products using ecological materials and energy-saving technologies. Offices and production facilities are ecologically designed, environmentally-aware and energy-saving. So Pilz offers sustainability, plus the security of using energy-efficient products and environmentally-friendly solutions.

Energy saving by Pilz



Pilz GmbH & Co. KG
Felix-Wankel-Straße 2
73760 Ostfildern, Germany
Tel.: +49 711 3409-0
Fax: +49 711 3409-133
info@pilz.com
www.pilz.com

PILZ
THE SPIRIT OF SAFETY