



PSEN ml b 1.1/2.1/2.2 PSEN ml DHM

PILZ
THE SPIRIT OF SAFETY

► PSEN sensor technology

This document is the original document.

Where unavoidable, for reasons of readability, the masculine form has been selected when formulating this document. We do assure you that all persons are regarded without discrimination and on an equal basis.

All rights to this documentation are reserved by Pilz GmbH & Co. KG. Copies may be made for the user's internal purposes. Suggestions and comments for improving this documentation will be gratefully received.

Pilz®, PIT®, PMI®, PNOZ®, Primo®, PSEN®, PSS®, PVIS®, SafetyBUS p®, SafetyEYE®, SafetyNET p®, the spirit of safety® are registered and protected trademarks of Pilz GmbH & Co. KG in some countries.



SD means Secure Digital

1	Introduction	6
1.1	Validity of documentation	6
1.2	Using the documentation	6
1.3	Definition of symbols	6
2	Safety	8
2.1	Intended use	8
2.2	Safety regulations	9
2.2.1	Safety assessment	9
2.2.2	Additional documents that apply	9
2.2.3	Use of qualified personnel	10
2.2.4	Warranty and liability	10
2.2.5	Disposal	10
2.3	For your safety	11
3	Overview	12
3.1	Approved combinations	12
3.2	Device features	13
4	Function description	14
4.1	Structure	14
4.2	Activation of safety inputs S31 and S41 (solenoid operation)	15
4.2.1	Activation with specification of direction	15
4.2.2	Activation without specification of direction	15
4.3	Safety Device Diagnostics	16
4.4	Operating modes	17
4.5	Block diagram	20
4.6	Auxiliary release	21
4.6.1	Recommissioning	21
4.7	Prevent restart	22
4.8	Escape release	22
4.8.1	Recommissioning	22
4.9	Accessories escape release	23
4.9.1	Recommissioning	25
5	Wiring	26
5.1	Important information	26
5.2	Pin assignment, connector and cable	26
5.3	EMC requirements	27
6	Connection to control systems and evaluation devices	28
6.1	Important information	28
6.2	Minimum requirements for activation of guard locking	29
6.3	Single connection	31
6.4	Connection to Pilz evaluation devices	32

7	Teaching in the actuator	33
8	Installation	34
8.1	Important information	34
8.2	Installation safety switch	35
8.2.1	Installation without mounting plate	36
8.2.2	Installation with mounting plate	36
8.2.3	Install fixing screws in parallel to actuator	37
8.2.4	Install fixing screws side-on to actuator	38
8.3	Actuator installation	39
8.3.1	Important information	39
8.3.2	Install actuator on swing gate	40
8.3.3	Install actuator on sliding gate	42
8.4	Escape release accessory	44
8.4.1	Important information	44
8.4.2	Installation positions for escape release	44
8.4.3	Installation stationary escape release	45
9	Adjustment	47
9.1	Attach safety switch and actuator	47
10	Operation	48
10.1	Normal operation mlock	48
10.2	Error display	50
11	Checks and maintenance	51
12	Dimensions	53
13	Technical details for safety switch	57
14	Technical details for actuator, order no. 6O000001-6O000004	61
15	Technical details for actuator, order no. 6O000005-6O000008	63
16	Technical details for escape release 570460	65
17	Classification according to ZVEI, CB24I	66
18	Safety characteristic data	67
19	Supplementary data	68
19.1	Radio approval	68
20	Order reference	69
20.1	System	69
20.2	Installation accessories	70
20.3	Cable accessories	70

21	Appendix	72
22	EC declaration of conformity	73

1 Introduction

1.1 Validity of documentation

This documentation is valid for the product PSEN ml b 1.1/2.1/2.2 from Version 2.0 together with the actuators PSEN ml DHM.

This operating manual explains the function and operation, describes the installation and provides guidelines on how to connect the product.

1.2 Using the documentation

This document is intended for instruction. Only install and commission the product if you have read and understood this document. The document should be retained for future reference.

1.3 Definition of symbols

Information that is particularly important is identified as follows:



DANGER!

This warning must be heeded! It warns of a hazardous situation that poses an immediate threat of serious injury and death and indicates preventive measures that can be taken.



WARNING!

This warning must be heeded! It warns of a hazardous situation that could lead to serious injury and death and indicates preventive measures that can be taken.



CAUTION!

This refers to a hazard that can lead to a less serious or minor injury plus material damage, and also provides information on preventive measures that can be taken.



NOTICE

This describes a situation in which the product or devices could be damaged and also provides information on preventive measures that can be taken. It also highlights areas within the text that are of particular importance.



INFORMATION

This gives advice on applications and provides information on special features.

2 Safety

2.1 Intended use

The safety gate system is used for interlocking and guard locking swing gates and sliding gates.

The safety gate system can be operated in two ways:

▶ **Unlocking with condition**

The safety gate system prevents the safety gate from being unlocked while there is any hazard within the danger zone.

▶ **Unlocking without condition**

The operator can unlock the safety gate system at any time. After starting the unlocking, the guard locking creates a stop command. The time required to unlock the interlocking guard has to be longer than the time required to stop the hazardous machine function.

The hazardous machine function may only be executed under the following conditions:

- ▶ There is a high signal at safety outputs 12 and 22 and
- ▶ There is a low signal at safety outputs S31 (Lock/Unlock Request 1) and S41 (Lock/Unlock Request 2).

Safety inputs S31 and S41 (solenoid operation) may only be operated under the following condition:

▶ **Plant is in a safe condition**

Make sure that this is the case with an AND operation in the safety system immediately before the output is operated.

The safety switch meets the requirements in accordance with:

- ▶ EN 60947-5-3: PDDDB
- ▶ EN 62061: SIL CL 3
 - EN ISO 13849-1: PL e (Cat. 4)
- ▶ EN ISO 14119
 - Coding level with actuator PSEN ml b 1.1: low, type 4
 - Coding level with actuator PSEN ml b 2.1/2.2: high, type 4

The safety switch may only be used with one of the approved actuators (see [Approved combinations](#)  12]).

The safety level PL e (Cat. 4)/SIL CL 3 is only achieved if

- ▶ For the interlock, the safety outputs have 2-channel processing
- ▶ For the guard locking device, the solenoid has 2-channel operation via safe, tested outputs, suitable for PL e (Cat. 4)/SIL CL 3 applications.

With 1-channel operation of the safety inputs S31 (Lock/Unlock Request 1) and S41 (Lock/Unlock Request 2) it is only possible to achieve safety level PL d (Cat. 2)/SIL CL 2.



NOTICE

Shock stress exceeded: if the safety switch is used together with one of the actuators PSEN ml DHM (as described in this document), the max. acceleration is reduced to 10g.

Foreseeable misuse

- ▶ Safety switches and actuators of the safety gate system must not be used as mechanical limit stops
- ▶ Use of the under corrosive environmental conditions (cooling emulsions, surface treatment, gases, ...)
- ▶ Use in environments with high dust pollution

2.2 Safety regulations

2.2.1 Safety assessment

Before using a device, a safety assessment in accordance with the Machinery Directive is required.

The product as an individual component fulfils the functional safety requirements in accordance with EN ISO 13849 and EN 62061. However, this does not guarantee the functional safety of the overall plant/machine. To achieve the relevant safety level of the overall plant/machine's required safety functions, each safety function needs to be considered separately.

2.2.2 Additional documents that apply

Please read and take note of the following documents.

Only for use of the Safety Device Diagnostics (SDD)

- ▶ Fieldbus module operating manual, for example SDD ES PROFINET
- ▶ System description "Safety Device Diagnostics"

For the use of passive junctions

- ▶ Operating manual for a passive junction

You will need to be conversant with the information in these documents in order to fully understand this operating manual.

2.2.3 Use of qualified personnel

The products may only be assembled, installed, programmed, commissioned, operated, maintained and decommissioned by persons who are competent to do so.

A competent person is a qualified and knowledgeable person who, because of their training, experience and current professional activity, has the specialist knowledge required. To be able to inspect, assess and operate devices, systems and machines, the person has to be informed of the state of the art and the applicable national, European and international laws, directives and standards.

It is the company's responsibility only to employ personnel who

- ▶ Are familiar with the basic regulations concerning health and safety / accident prevention,
- ▶ Have read and understood the information provided in the section entitled Safety
- ▶ Have a good knowledge of the generic and specialist standards applicable to the specific application.

2.2.4 Warranty and liability

All claims to warranty and liability will be rendered invalid if

- ▶ The product was used contrary to the purpose for which it is intended,
- ▶ Damage can be attributed to not having followed the guidelines in the manual,
- ▶ Operating personnel are not suitably qualified,
- ▶ Any type of modification has been made (e.g. exchanging components on the PCB boards, soldering work etc.).

2.2.5 Disposal

- ▶ In safety-related applications, please comply with the mission time T_M in the safety-related characteristic data.
- ▶ When decommissioning, please comply with local regulations regarding the disposal of electronic devices (e.g. Electrical and Electronic Equipment Act).

2.3 For your safety

- ▶ Do not remove the connector's protective cap until you are just about to connect the unit. This will prevent potential contamination.



WARNING!

Risk of injury due to loss of the safety function

Substituting an actuator for an inappropriate actuator of the interlock and guard locking system may lead to serious injury and death.

- You should prevent the interlocking and guard locking system from being manipulated with an inappropriate actuator.
- Keep the substitute actuator (optional) in a safe place and protect it from unauthorised access.
- Install substitute actuators (optional) as described in [Installation](#) [ 34].
- Destroy any used actuators before disposal.

3 Overview

3.1 Approved combinations

An approved combination (unit) consists of a safety switch and the corresponding actuator. For information such as product type, features and order number, see [Order reference](#) [📖 69].

PSEN ml b 1.1

Safety switch	Actuator
PSEN ml b 1.1 switch	PSEN ml DHM up l 1.1
	PSEN ml DHM up r 1.1
	PSEN ml DHM down l 1.1
	PSEN ml DHM down r 1.1

PSEN ml b 2.X

Safety switch	Actuator
PSEN ml b 2.1 switch	PSEN ml DHM up l 2.1
	PSEN ml DHM up r 2.1
	PSEN ml DHM down l 2.1
	PSEN ml DHM down r 2.1
PSEN ml b 2.2 switch	PSEN ml DHM up l 2.1
	PSEN ml DHM up r 2.1
	PSEN ml DHM down l 2.1
	PSEN ml DHM down r 2.1

The available actuators are combined in this document as follows.

Product type	Designation in this document
PSEN ml DHM up l 1.1	PSEN ml DHM
PSEN ml DHM up l 2.1	
PSEN ml DHM up r 1.1	
PSEN ml DHM up r 2.1	
PSEN ml DHM down l 1.1	
PSEN ml DHM down l 2.1	
PSEN ml DHM down r 1.1	
PSEN ml DHM down r 2.1	

3.2 Device features

- ▶ Safe guard locking for swing gates and sliding gates
- ▶ Safe interlocking (position monitoring)
- ▶ Transponder technology
- ▶ 2 safety outputs
- ▶ Safety Device Diagnostics (SDD)
 - Safety Device Diagnostics can be used to poll sensor information, to perform actions and to read configuration parameters
 - Manipulation protection in accordance with ISO 14119 is possible by verifying the short name of the actuator through the controller via SDD communication
- ▶ Diagnostic input for Y1 for Safety Device Diagnostics (SDD)
- ▶ Signal output/diagnostic output Y32 for Safety Device Diagnostics
- ▶ Monitoring of shorts between the safety outputs
- ▶ Guard locking element keeps the safety gate from being opened unintentionally
- ▶ Auxiliary release for opening the safety gate
- ▶ 1 signal output
- ▶ Suitable for left and right hinged safety gates
- ▶ Pilz coding type
 - PSEN ml b 1.1: coded
 - PSEN ml b 2.1: fully coded
 - PSEN ml b 2.2: uniquely coded
- ▶ M12, 8-pin male connector
- ▶ LEDs:
 - Supply voltage/fault
 - Status of actuator
 - Status of guard locking
 - Input lights up yellow (without function)
- ▶ Escape release in accordance with EN ISO 14119

The escape release enables manual release of guard locking from **inside** the danger zone without aids and corresponds to escape unlocking.
- ▶ Actuator with door handles and integrated escape release

4 Function description

4.1 Structure

The interlocking and guard locking system prevents the safety gates to the danger zone from being opened while there is any hazard within the danger zone (machine movement, voltage, ...).

The safety outputs may have a high or low signal, depending on the position of the actuator and the signal path of safety inputs S31 and S41 (solenoid operation).

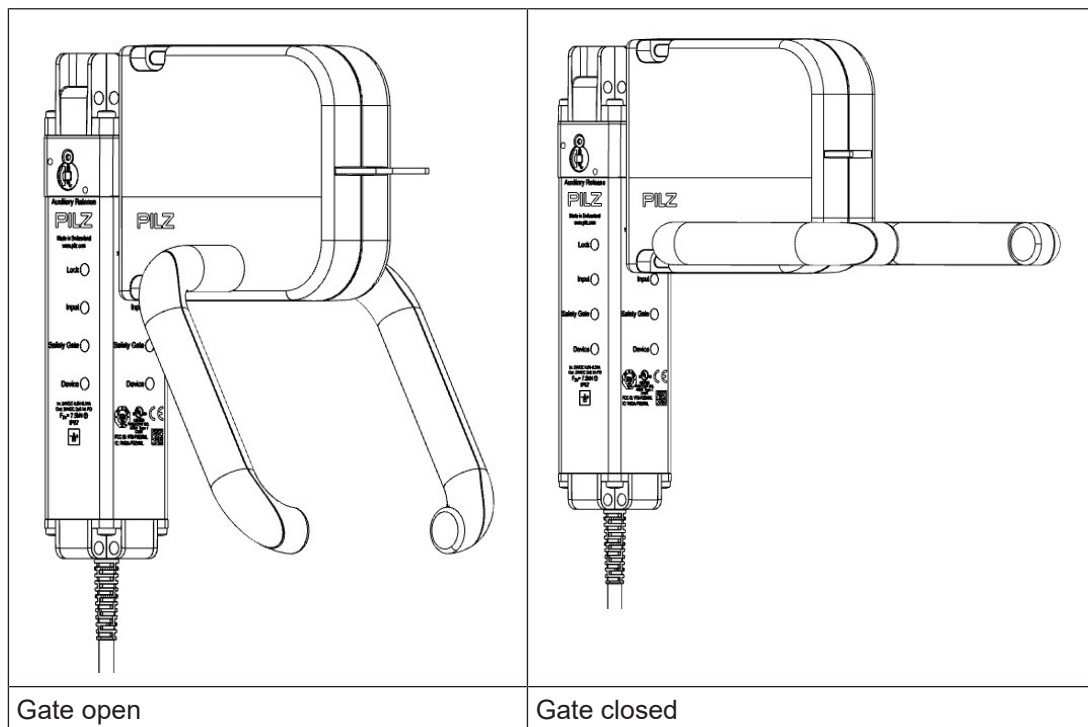

Safety outputs 12 and 22

Under these conditions there is a high signal at safety outputs 12 and 22:

- ▶ Actuator is detected **and**
- ▶ Guard locking pin has successfully been activated (guard locking pin is in the locked position)

If one of these conditions is not met, the signal at the safety outputs will be low.

- ▶ Diagnostic input Y1

If a fieldbus module of the SDD is used, the diagnostic input Y1 is automatically activated and data is read.

If no fieldbus module of the SDD is used, the diagnostic input Y1 must not be used.

- ▶ Signal output/diagnostic output Y32

The status of the actuator is output. If a fieldbus module of the SDD is used, the signal output/diagnostic output for the writing of data is activated.

4.2 Activation of safety inputs S31 and S41 (solenoid operation)

- ▶ If there is a low signal at safety inputs S31 and S41, the guard locking pin does not change its position.
- ▶ Guard locking may only be deactivated once the hazardous movement has been completed.

Active use of Safety Device Diagnostics

- ▶ The safety inputs S31 and S41 have a high signal within max. 500 ms after the receipt of the guard locking activation.

Guard locking is activated through a high signal (duration 350 - 400 ms) at inputs S31 and S41 (solenoid operation). After activation, the inputs must be low. Another pulse (duration 350 - 400 ms) at these inputs deactivates guard locking.

4.2.1 Activation with specification of direction

- ▶ The guard locking is activated when the time between the rising edges from S31 to S41 is between 40 ms and 500 ms (S31 before S41).
- ▶ The guard locking is deactivated when the time between the rising edges from S31 to S41 is between 40 ms and 500 ms (S41 before S31).

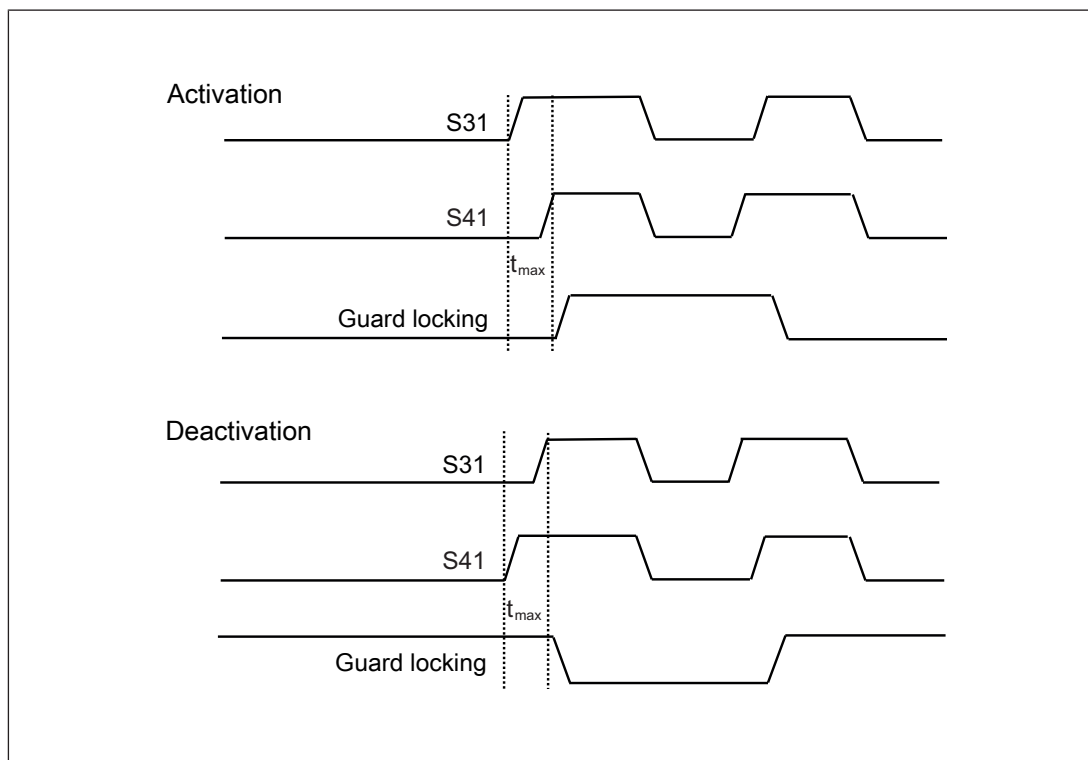

Legend

t_{\max} Maximum time between the rising edges from S31 and S42

4.2.2 Activation without specification of direction

- ▶ The guard locking changes its state when the time between the rising edges from S31 and S41 < 20 ms.

4.3 Safety Device Diagnostics

Safety Device Diagnostics is an option that can be selected independently of the safety-related wiring.

When using the Safety Device Diagnostics, up to 16 sensors can be connected as a subscriber to a fieldbus module.

The communication of the sensors with the fieldbus module is automatically built up again with each new supply of the supply voltage. As a result, a sensor can be exchanged, e.g. when servicing, without the need for special measures.

An exchange can be detected via the fieldbus module e.g. through the serial number.

- ▶ With Safety Device Diagnostics there are the following diagnostic options for the fieldbus module:
 - Poll information of the sensors (examples: what sensor in the series has switched, at what point could there be an open circuit in the series connection)
 - Read configuration parameters of the sensor (examples: Number of teach-in processes remaining, serial number of the switch)
 - Perform actions (example: poll updated actuator name)
 - Selectively activate or deactivate guard locking of individual PSEN ml within a series connection

The results of the sensor diagnostics can be checked already during the installation phase via the display in the fieldbus module, without the need to connect the fieldbus module to the network.

- ▶ With Safety Device Diagnostics there are the following diagnostic options for the fieldbus module for simple wiring:

- Information is passed on via the fieldbus module directly to the network
- Mappings of the signal outputs to the sensor are automated by the SDD.

This prevents wiring errors and an expansion or reduction of the sensors is possible without the need to change existing wiring.

- Wiring in accordance with IP20: Rapid installation in the control cabinet is enabled.

Further information on Safety Device Diagnostics can be found in [Additional documents that apply](#)  9].

4.4 Operating modes

The safety switch can be used in various operating modes.

- ▶ Operation without safety device diagnostics
 - Standard operating mode
After every restart the safety switch is in operation without Safety Device Diagnostics.
 - No communication with Safety Device Diagnostics
 - Activating/deactivating the guard locking is only via the signals S31 and S41
- ▶ Operation with passive use of the Safety Device Diagnostics
 - Safety switch supplies diagnostic data to Safety Device Diagnostics
 - Activating/deactivating the guard locking is only via the signals S31 and S41
- ▶ Operation with active use of the Safety Device Diagnostics
 - Activate/deactivate the guard locking by a combination of a Safety Device Diagnostics command and the status of the safety inputs S31 and S41 (S31 and S41 must have a high signal).
The safety requirements are guaranteed by the signals S31 and S41 (the fieldbus for Safety Device Diagnostics communication is not safe).
- ▶ Operation with specified direction when activating/deactivating guard locking

A specified direction can be used to control switching of the guard locking status.

 - Toggle: The safety switch changes the guard locking status (activated <-> deactivated) each time S31 and S41 are activated simultaneously.
 - Force direction: The safety switch is selectively activated or deactivated by offset activation of the rising edges at S31 and S41.

Timing diagrams

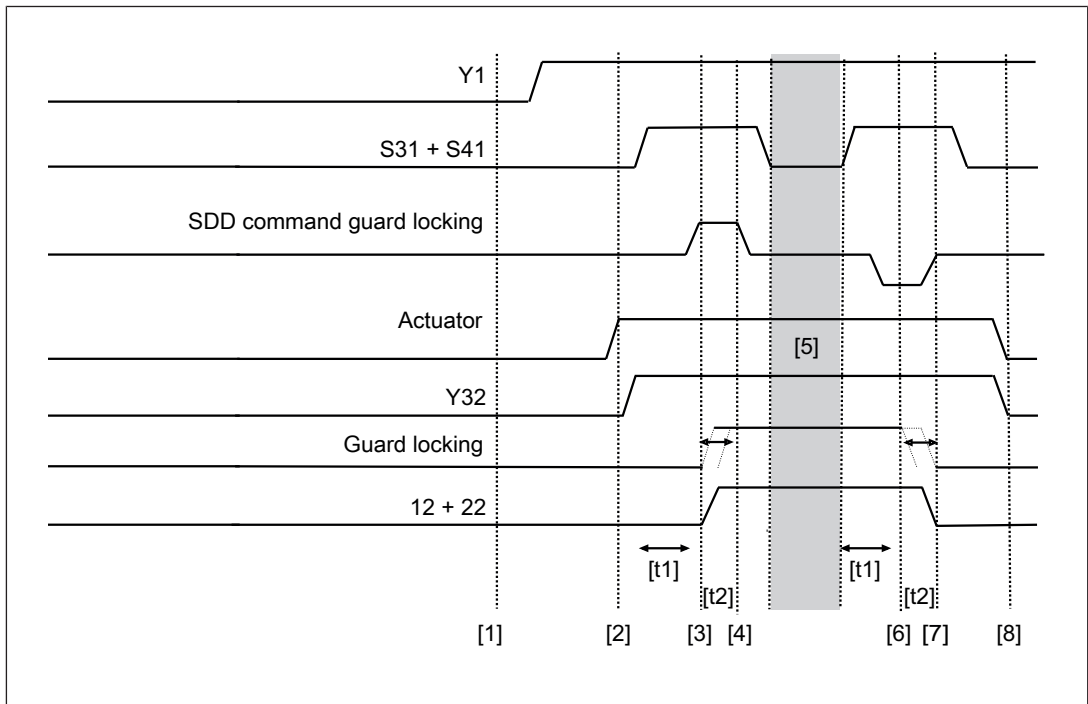

Fig.: Active use of Safety Device Diagnostics

Legend

- [1] Gate is open
- [2] Gate is closed
- [3] Guard locking is activated by the safety control system
- [4] Guard locking is activated
- [5] Execution of the hazardous machine function is permitted
- [6] Outputs will be deactivated
- [7] Guard locking will be deactivated
- [8] Gate is open
- [t1] Processing time of guard locking signal = 100 ms
- [t2] Time window for changing guard locking status

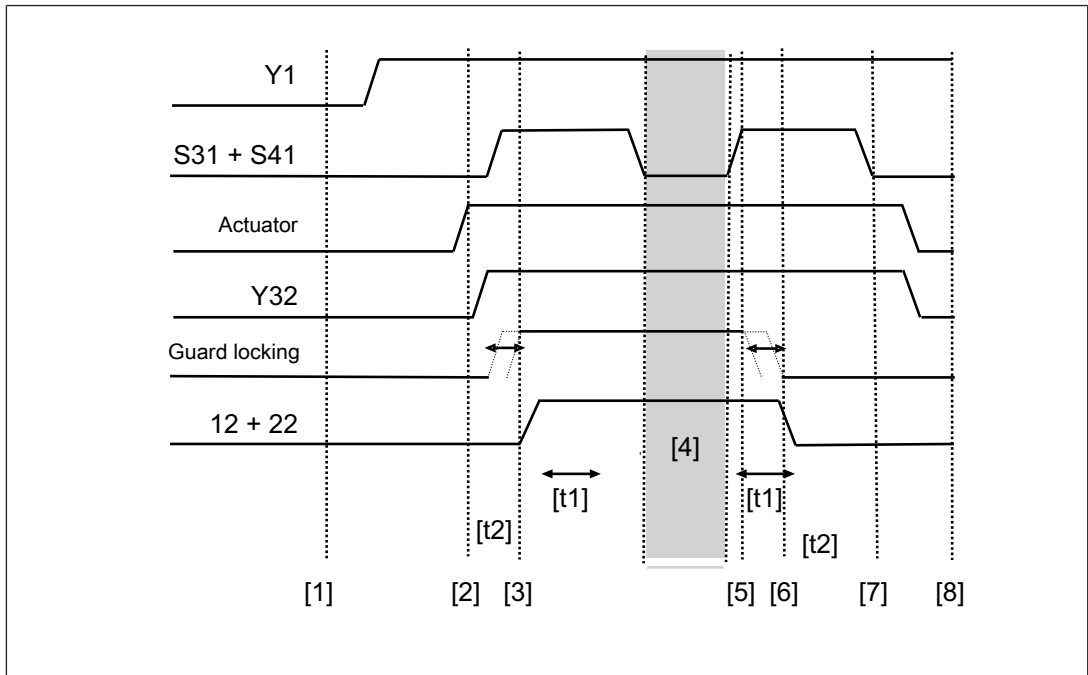
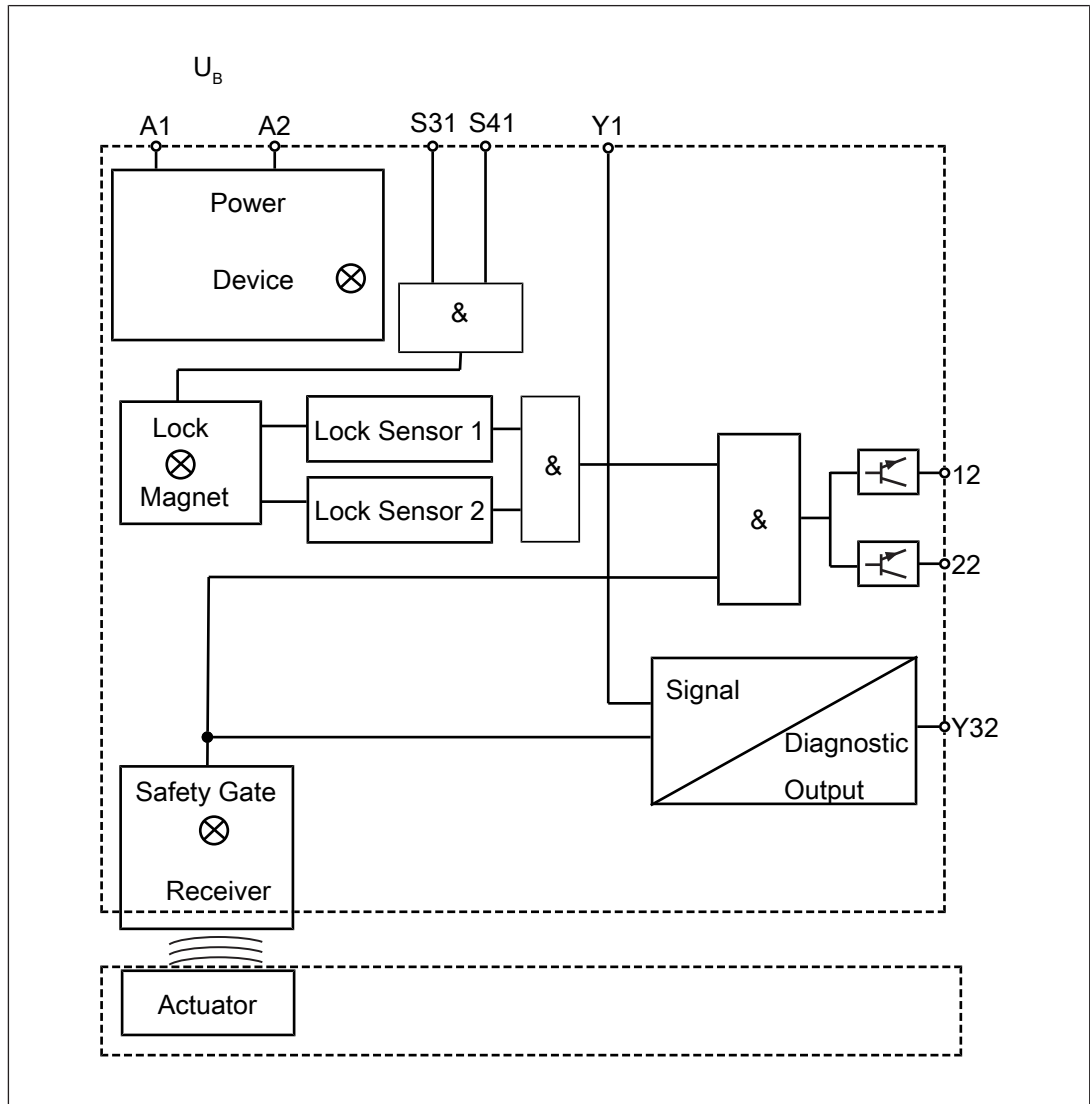

Fig.: Passive use of the Safety Device Diagnostics

Legend

- [1] Gate is open
- [2] Gate is closed
- [3] Guard locking is activated
- [4] Execution of the hazardous machine function is permitted
- [5] Outputs will be deactivated
- [6] Guard locking will be deactivated
- [7] Gate is open
- [t1] Processing time of guard locking signal = 100 ms
- [t2] Time window for changing guard locking status

4.5 Block diagram



4.6 Auxiliary release

The auxiliary release enables guard locking to be opened from the access side to the danger zone.

The safety switch has auxiliary releases on three sides.

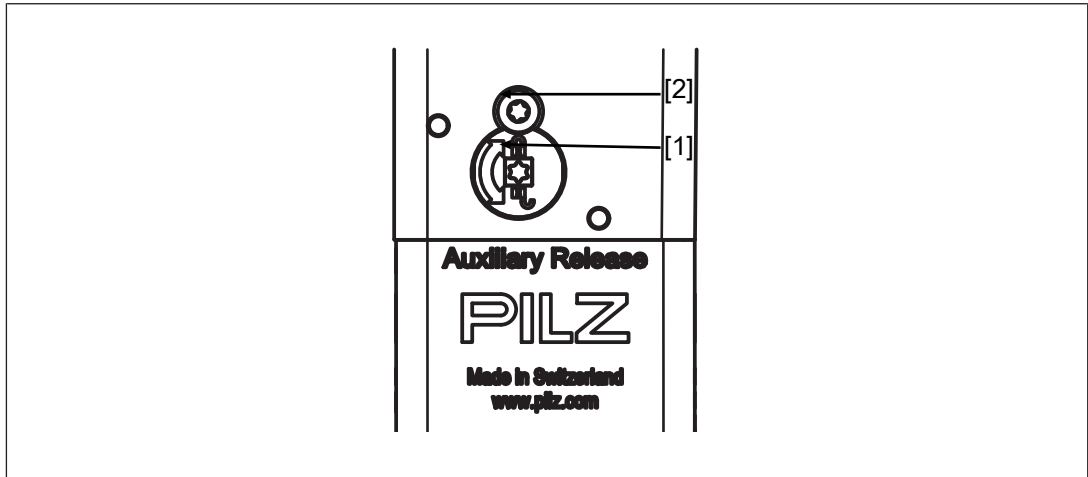

Legend

- [1] Auxiliary release screw Torx T10
- [2] Security screw Torx T10, sealed with varnish when delivered

Mode of operation

1. Remove the security screw [2] using a Torx T10 screwdriver.
2. Rotate the auxiliary release screw [1] half a turn anti-clockwise using a Torx T10 screwdriver. The guard locking pin is displaced and the bolt is released.

The safety gate to the danger zone can be opened.



INFORMATION

If guard locking is deactivated using the auxiliary release, there is a low signal at safety outputs 12 and 22. An error code will be issued (see under [Operation](#) [49]) and the safety switch switches to a fault condition.

It is possible to open guard locking using the control system.

4.6.1 Recommissioning

Recommission the safety switch

1. Rotate the auxiliary release screw [1] (see [Figure](#) [21]) half a turn clockwise using a Torx T10 screwdriver.
2. Re-insert the security screw [2] (see [Figure](#) [21]) using a Torx T10 screwdriver.
3. Seal the security screw with varnish.
4. Switch the voltage off and then on again.

5. Carry out a function test on the safety switch and actuator. The safety function may only be checked by qualified personnel.



INFORMATION

If the auxiliary release screw is not turned back correctly after use, the safety switch switches to a fault condition.

4.7 Prevent restart

To prevent the machine restarting (unintentionally) while there is someone inside the danger zone, the actuator can be secured using padlocks (see diagram). As a result the actuator cannot engage with the safety switch, guard locking is not activated and the machine is prevented from starting.

- ▶ Minimum 2, maximum 6 padlocks
- ▶ Padlock bow diameter
 - ≤ 6 mm with maximum 6 padlocks
 - ≤ 7 mm with maximum 3 padlocks

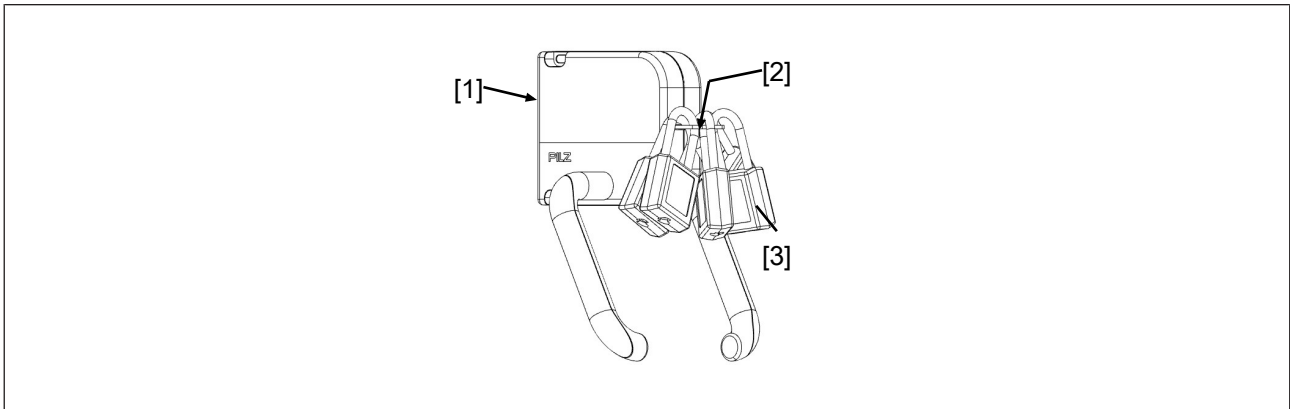

Legend

- [1] Actuator PSEN ml DHM
- [2] Flap on the actuator PSEN ml DHM for attaching the padlocks
- [3] Padlock

4.8 Escape release

The actuator PSEN ml DHM enables manual release of guard locking via an escape release handle. The escape release handle is inside the danger zone. So the actuator corresponds to an escape release in accordance with EN ISO 14119.

4.8.1 Recommissioning

1. Reset the handle.
2. Switch the voltage off and then on again.

3. Carry out a function test using the escape release. The safety function may only be checked by qualified personnel.

4.9 Accessories escape release

If the escape release accessory (order no. 570460) is installed outside the danger zone, the accessory can be used as an emergency release in accordance with EN ISO 14119.

- ▶ The emergency release enables the manual release of the guard locking without aids from outside the hazardous area.

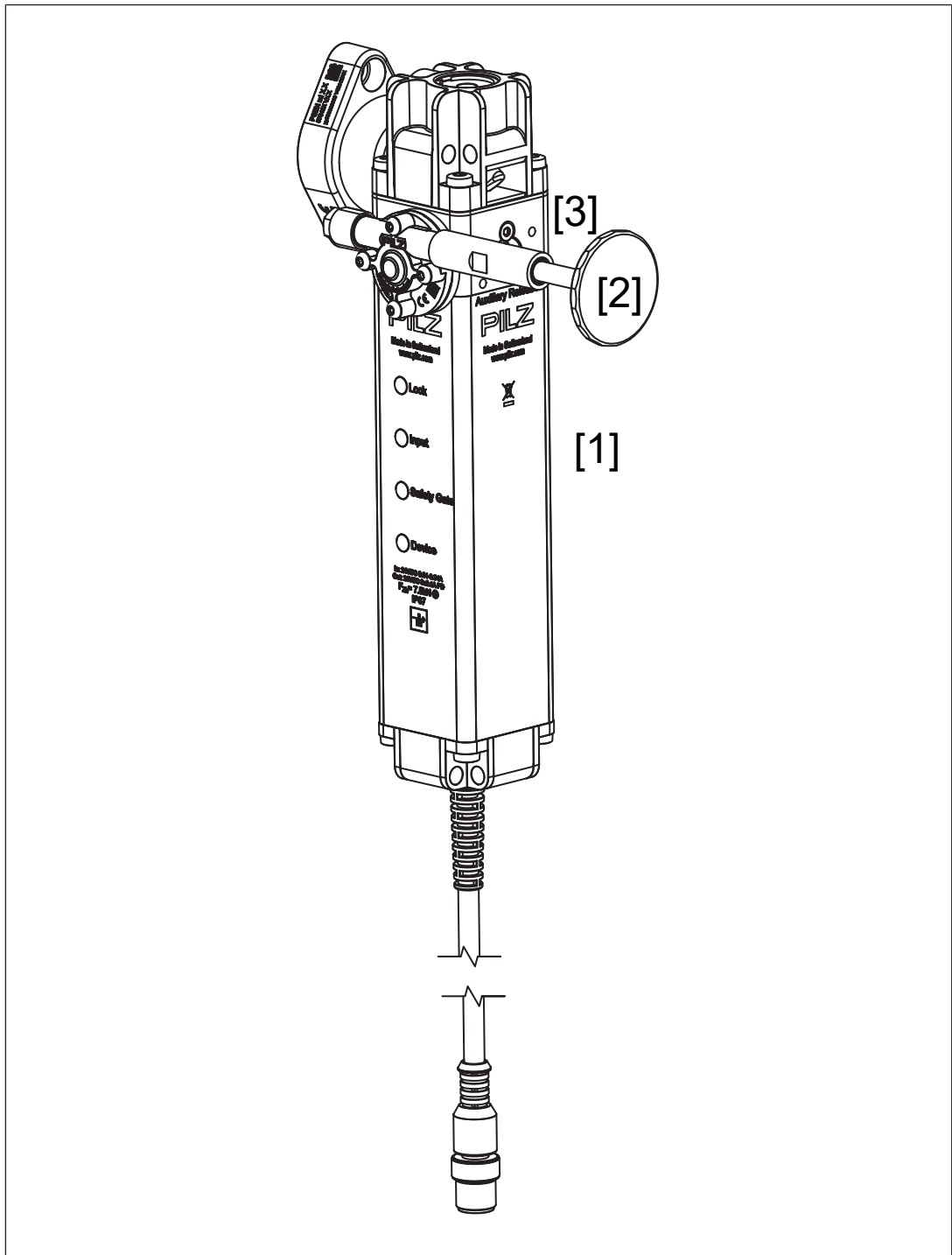

Legend

- [1] Escape release stationary
- [2] Button of the escape release pin
- [3] Escape release pin



INFORMATION

If guard locking is deactivated using the auxiliary release, there is a low signal at safety outputs 12 and 22. An error code will be issued (see under [Operation \[📖 49\]](#)) and the safety switch switches to a fault condition.

Mode of operation

In the danger zone, if the button of the escape release pin is pressed towards the safety gate, the escape release impacts directly on the auxiliary release of the safety switch and the auxiliary release unlocks the safety gate. The safety gate can be opened immediately, enabling the operator to leave the danger zone.

There is a low signal at safety outputs 12 and 22 if the escape release was operated.

4.9.1

Recommissioning

1. Pull back the button of the escape release pin.
2. Switch the voltage off and then on again.
3. Carry out a function test using the escape release. The safety function may only be checked by qualified personnel.

5 Wiring

5.1 Important information

- ▶ Hand-tighten the connector.
- ▶ Information given in the [Technical details \[57\]](#) must be followed.
- ▶ Note the max. cable length when operating with Safety Device Diagnostics.

Supply voltage on the safety control system	Max. cable length
≥ 20.4 V	50 m
≥ 24 V	120 m
≥ 28.8 V	180 m

5.2 Pin assignment, connector and cable



NOTICE

The colour marking for the connection lead only applies for the cable that Pilz supplies as an accessory

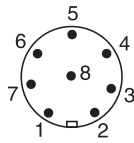

8-pin M12 connector

PIN	Function	Terminal designation	Cable colour (Pilz cable)
1	Operation of solenoid to open and close guard locking (channel 2)	S41	white
2	+24 V UB	A1	Brown
3	Safety output channel 1	12	Green
4	Safety output channel 2	22	Yellow
5	Signal output/diagnostic output	Y32	grey
6	Operation of solenoid to open and close guard locking (channel 1)	S31	Pink
7	0 V UB	A2	Blue
8	Diagnostics input	Y1	Red

5.3 EMC requirements

- ▶ Ensure the wiring and EMC requirements of EN 60204-1 are met.
- ▶ UL requirement: The supply voltage to the safety switch must be protected with a quick-acting fuse (see [Technical details](#) [ 57]).
- ▶ The inputs and outputs of the safety switch must have a protective separation to voltages over 60 VDC.
- ▶ The power supply must meet the regulations for extra low voltages with protective electrical separation (SELV, PELV).



INFORMATION

Only use safety relays with a 24 VDC supply voltage. Safety relays with a wide-range power supply or in AC device versions have internal potential isolation and are not suitable as evaluation devices.

6 Connection to control systems and evaluation devices

6.1 Important information

The selected evaluation device must have the following properties:

- ▶ 2-channel with plausibility monitoring

Both OSSDs must change the switch state synchronously. In particular, the evaluation device must monitor that the state of both OSSDs was "Gate unlocked" before both return to the "Gate locked" state and vice-versa.

- ▶ OSSD signals are evaluated through 2 channels.
- ▶ The state of the OSSDs must be tested before and after safety inputs S31 and S41 are activated (solenoid operation) (see [Timing diagram \[18\]](#)).
- ▶ The use of Safety Device Diagnostics is described in the System Description "Safety Device Diagnostics".



WARNING!

Hazard due to loss of the safety function

Depending on the application, serious injury or death may result. The safety function can be lost when the safe state is not checked regularly.

- Use an evaluation device/safety system to test whether the plant is in a safe condition.
- Do not operate the solenoid via S31/S41 unless the plant is in a safe condition.

6.2 Minimum requirements for activation of guard locking

Use in PL e (Cat. 4) applications

- ▶ Safety inputs S31 and S41 (solenoid operation) have 2-channel operation via safe outputs, which are suitable for PL e (Cat. 4) applications
- ▶ 2-channel operation for safety inputs S31 and S41 (solenoid operation), each with 0.5 A
- ▶ 2-channel processing of safety outputs
- ▶ Monitoring of shorts across signal cables through activation of guard locking

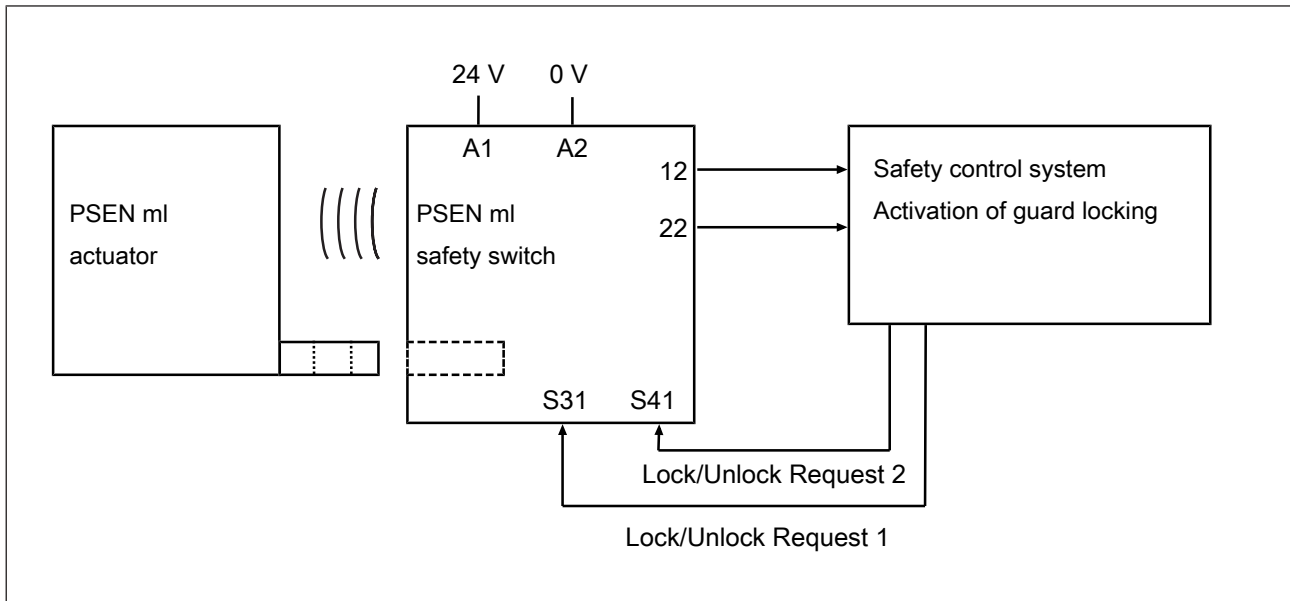

Use in PL d (Cat. 3) applications

- ▶ 2-channel operation for safety inputs S31 and S41 (solenoid operation) via safe relay outputs
- ▶ 2-channel operation for safety inputs S31 and S41 (solenoid operation), each with 0.5 A
- ▶ 2-channel processing of safety outputs
- ▶ Exclusion of shorts across signal cables through appropriate measures (e.g. protected cable layout, see EN ISO 13849-2)

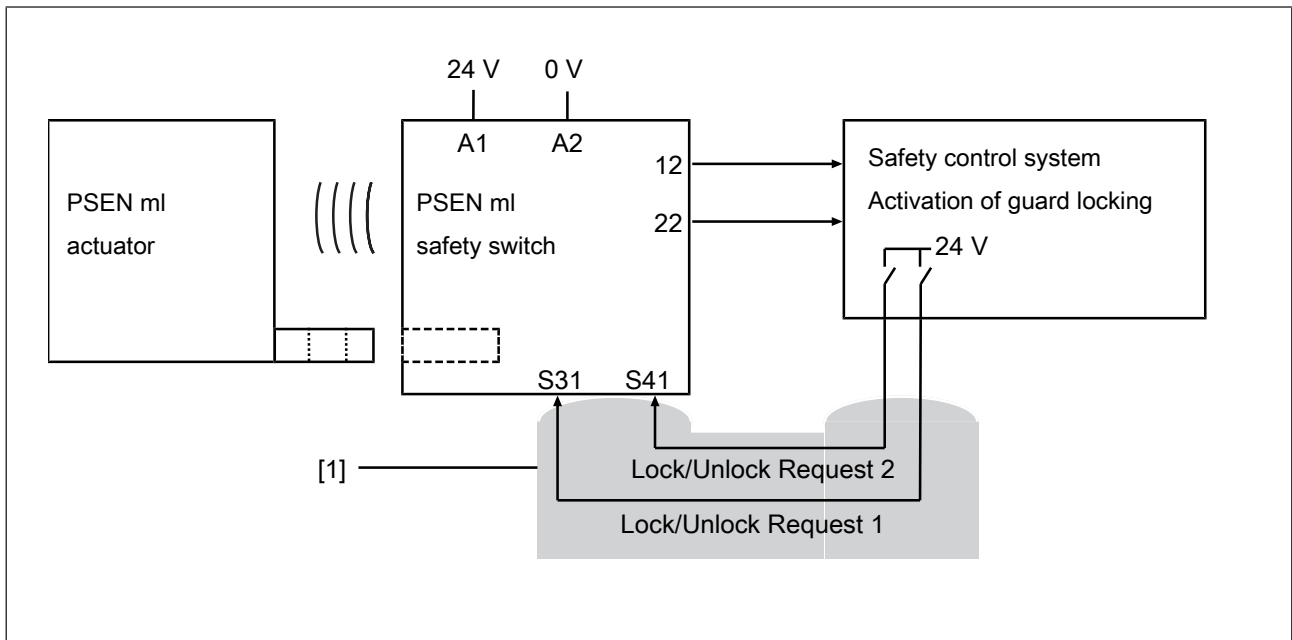

Legend

[1] Protected cable layout

Use in PL d (Cat. 2) applications

- ▶ 1-channel operation for safety inputs S31 and S41 (solenoid operation) via safe outputs
- ▶ 2-channel processing of safety outputs
- ▶ 1-channel operation for interconnected safety inputs S31 and S41 (solenoid operation), with 1 A

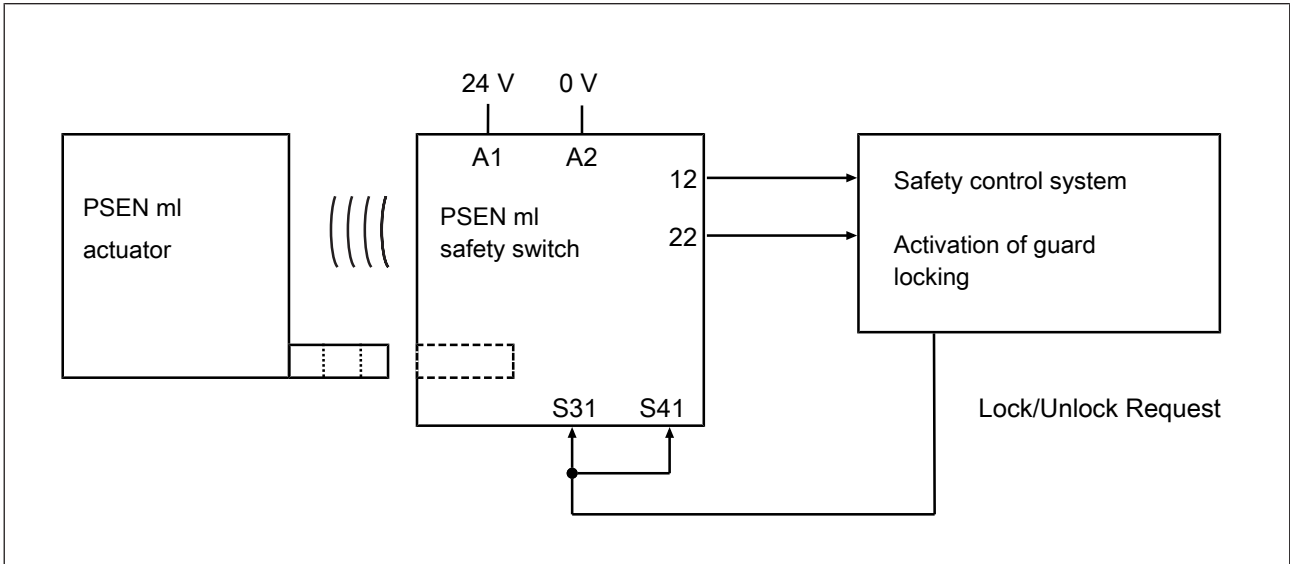

6.3 Single connection

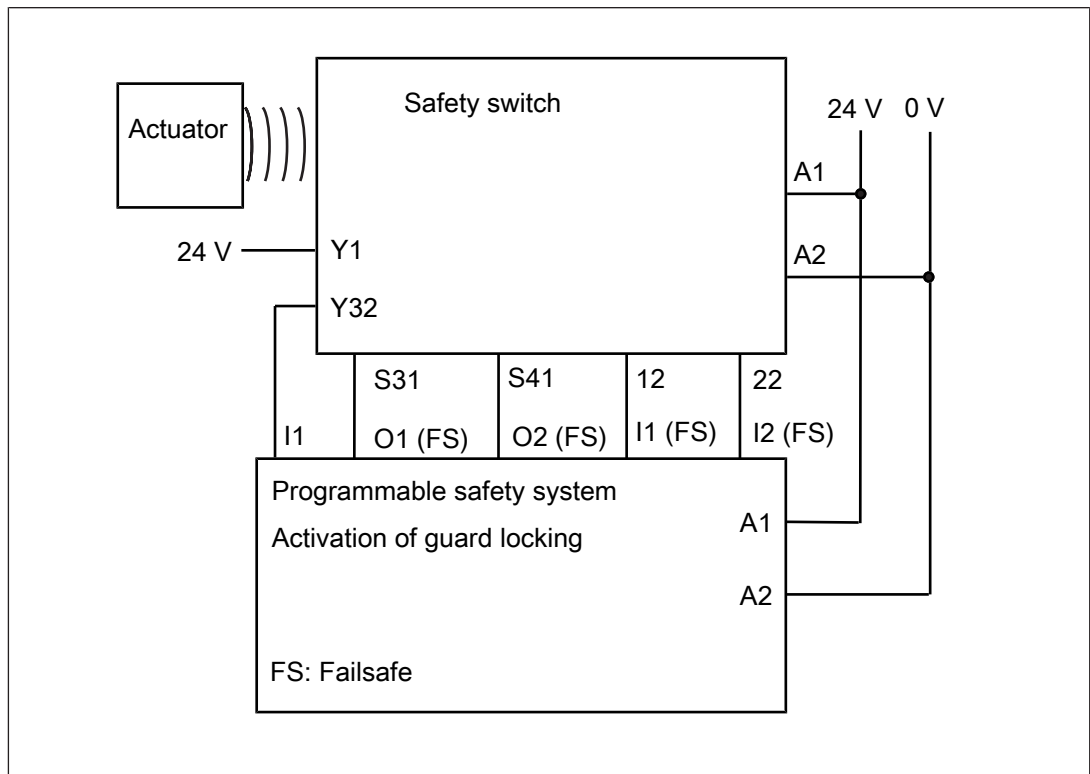

6.4 Connection to Pilz evaluation devices

The safety switch can be connected to Pilz evaluation devices.

Suitable Pilz evaluation devices are, for example:

- ▶ PNOZmulti for safety gate monitoring
Configure the switch in the PNOZmulti Configurator with switch type 3.
- ▶ PSSuniversal PLC for safety gate monitoring with function block FS_SafetyGate

The correct connection to the respective evaluation device is described in the operating manual for the evaluation device. Make sure that the connection is made in accordance with the specifications in the operating manual for the selected evaluation device.

Connection to PNOZmulti is illustrated by way of example.

Connection example with PNOZmulti and Safety Device Diagnostics

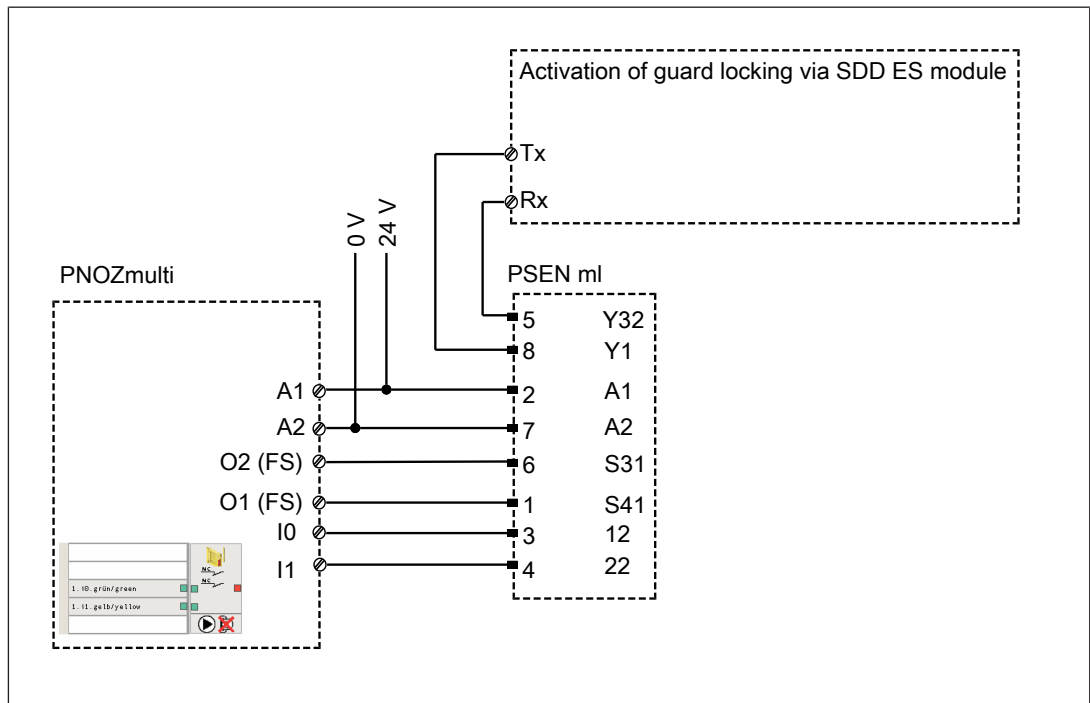

7 Teaching in the actuator

PSEN ml b 1.1

Any corresponding Pilz actuator (see [Technical Details \[57\]](#)) is detected as soon as it is brought into the response range.

PSEN ml b 2.1

Teaching in the actuator for the first time:

The first actuator to be detected by the safety switch (see [Technical details \[57\]](#)) is taught in automatically as soon as it is brought into the response range.

To teach in a new actuator:

- ▶ A maximum of 8 learning procedures are possible.
- 1. The actuator that is to be taught in must be brought into the safety switch's response range as the only transponder. As soon as the actuator is detected, the "Safety Gate" LED will flash yellow.
- 2. After 20 s has elapsed, the "Safety Gate" LED turns to quick yellow flashes. Trigger a system reset in the next 120 s by interrupting the power supply.
- 3. When the supply voltage is switched back on, the learning procedure is complete and the number of permitted additional learning procedures is reduced by 1.



NOTICE

- The actuator must not be removed during the learning procedure.
- This actuator cannot be retaught on the same safety switch.

PSEN ml b 2.2

The first actuator to be detected by the safety switch (see [Technical details \[57\]](#)) is taught in automatically as soon as it is brought into the response range.



NOTICE

No other actuator may be taught in once this actuator has been taught.

8 Installation

8.1 Important information







NOTICE

Install the safety switch and actuator so that the possibilities of defeat are reduced to a minimum (see guidelines for reducing the possibilities for defeating interlocking devices in EN ISO 14119).



NOTICE

Install safety switch and actuator so that it is not possible to reach through with hand or finger.

- ▶ The fastening of safety switch and actuator has to be sufficiently stable to ensure the proper operation of the safety switch and the actuator.
- ▶ Prevent the safety switch and actuator being exposed to heavy shock or vibration.
- ▶ Installation of the safety switch and actuator must be concealed.
- ▶ The mounting surfaces for safety switches and actuators can have a max. unevenness of 0.5 mm.
- ▶ The actuator must rest flush on the mounting surface.
- ▶ The safety switch and actuator should be installed opposite each other in parallel.
- ▶ After installation, at least one of the auxiliary releases/escape releases must be operated.
- ▶ Use the same type of screw to attach the safety switch and actuator.
- ▶ Use non-removable flat head locking screws to attach the safety switch and actuator (e.g. cheese-head or pan head screws) or rivets.
- ▶ For a minimum screw depth of 6 mm, M5 screws and M8 screws with resistance class 8.8 should be used to attach the safety switch and actuator.
- ▶ Prevent self-loosening of the fastening elements,
 - On the safety switch: By complying with the max. torque setting (see [Technical details](#)  57).
 - On the actuator: By complying with the max. torque setting (see [Technical details](#)  57) and medium-strength threadlockers.
- ▶ Torque setting: Please note the information provided under [Technical details](#)  57. Don't fully tighten the safety screws until the safety switches and actuators are correctly aligned and the function has been tested (see [Adjustment](#)  47).
- ▶ Installation of the safety switch and actuator must be concealed.

8.2 Installation safety switch

- ▶ To fix the safety switch at the three possible mounting positions, there are three drill holes on three sides.

As a result, the safety switch can be installed on the frames of left and right hinged sliding gates and swing gates. If necessary use a [Mounting plate](#) [📖 36] (see [Order reference: Accessories](#) [📖 70]).

Different holding forces arise, based on the installation.

- Installation on sliding gates

Holding force $F_{Zn} = 2000 \text{ N}$

Holding force F_{1max} in accordance with EN ISO 14119 = 4000 N

- Installation on swing gates:

Holding force $F_{Zn} = 3000 \text{ N}$

Holding force F_{1max} in accordance with EN ISO 14119 = 6000 N

The tapped holes must have a depth of at least 6 mm.

Installation of safety switch	Tapped hole
Fixing screws in parallel/side-on to actuator, no mounting plate	Tapped holes for four M5 screws on the mounting surface.
Fixing screws in parallel/side-on to actuator, with mounting plate	Tapped holes for two M8 screws on the mounting surface, for attaching the mounting plate.

8.2.1 Installation without mounting plate

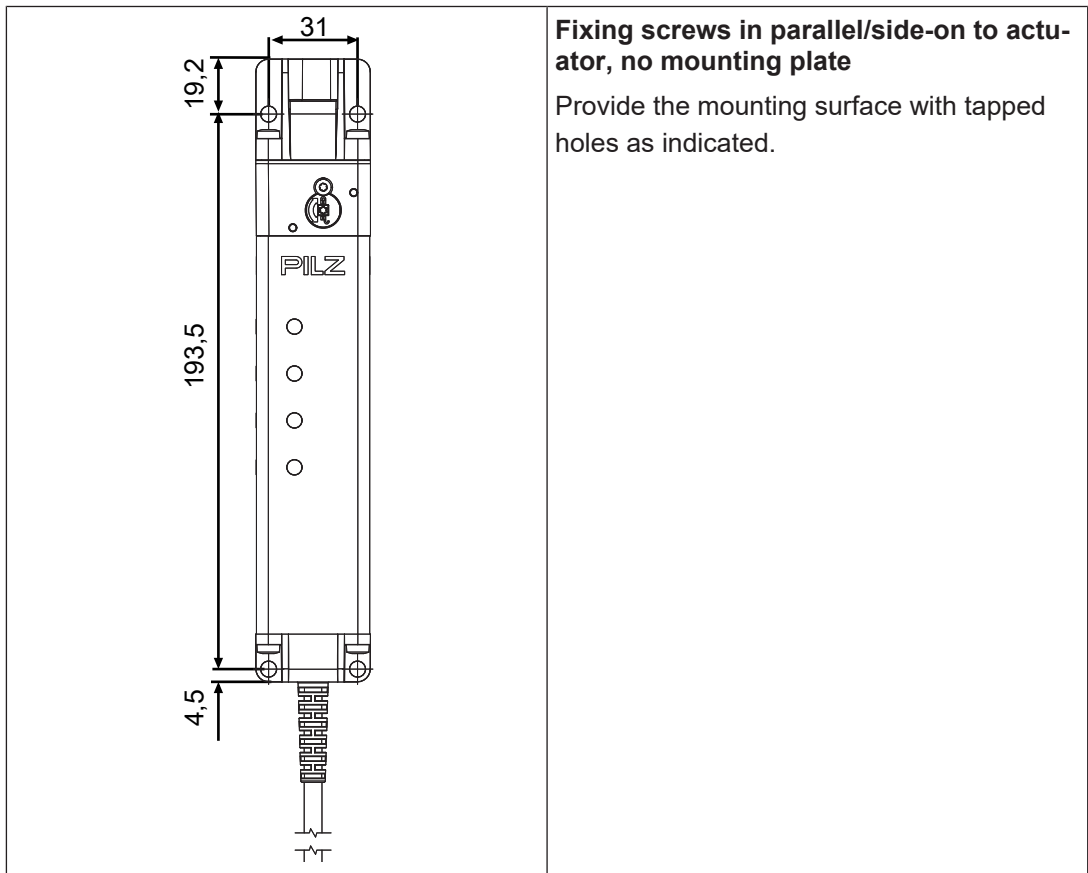

1. Attach the safety switch to the swing gate/sliding gate.
2. Use four M5 screws to fix the safety switch to the mounting surface.

8.2.2 Installation with mounting plate

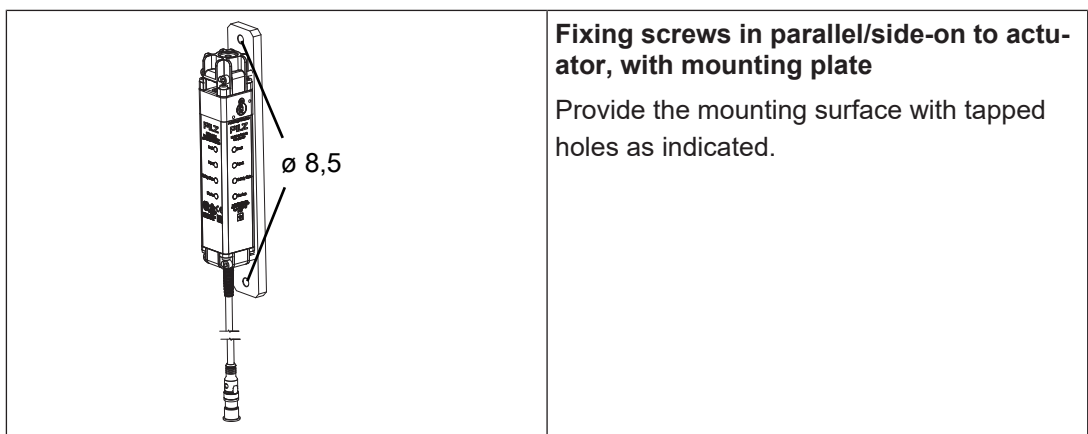

1. Attach the mounting plate to the swing gate/sliding gate.
2. Use four M5 screws to fix the safety switch to the mounting plate.



NOTICE

Correct distances when installing the actuator

The actuator must be attached at the same distance to the mounting surface as the safety switch.

If the safety switch is installed using a mounting plate, then the actuator **must** also be installed using a mounting plate (see [Install actuator on mounting plate](#) [40]).

8.2.3 Install fixing screws in parallel to actuator

Use four M5 screws to fix the safety switch to the mounting surface.

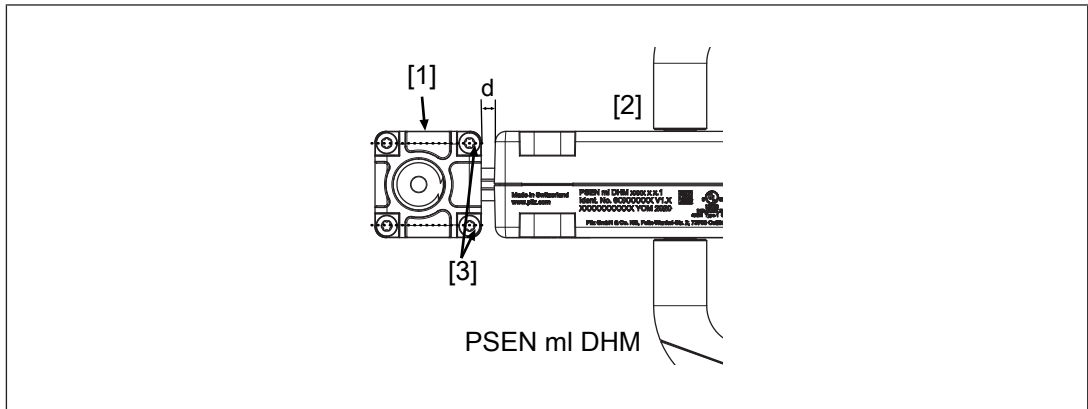

Legend

- [1] Safety switch
- [2] Actuator
- [3] Fixing screws of the safety switch crosswise to the respective actuator
- [d] Distance between safety switch and actuator: 5 ... 6 mm



WARNING!

Hazard due to defective escape release

If the distance between safety switch and actuator is too short, the escape release mechanism can be damaged and the user is unable to leave the danger zone. This can lead to lead to serious injury or death.

- During installation, maintain a distance of at least 5 mm between safety switch and actuator.
- Check the function of the escape release before commissioning and thereafter once a year.

8.2.4 Install fixing screws side-on to actuator

Use four M5 screws to fix the safety switch to the mounting surface.

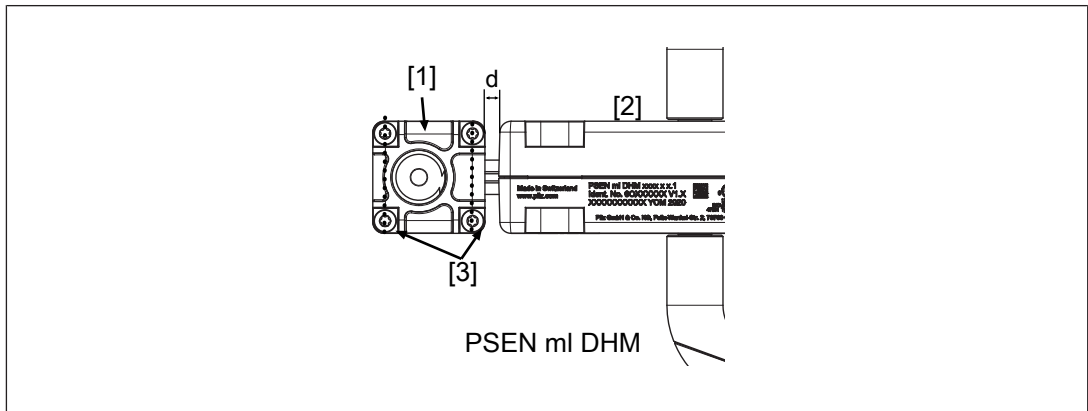

Legend

- [1] Safety switch
- [2] Actuator
- [3] Fixing screws of the safety switch crosswise to the respective actuator
- [d] Distance between safety switch and actuator: 5 ... 6 mm



WARNING!

Hazard due to defective escape release

If the distance between safety switch and actuator is too short, the escape release mechanism can be damaged and the user is unable to leave the danger zone. This can lead to lead to serious injury or death.

- During installation, maintain a distance of at least 5 mm between safety switch and actuator.
- Check the function of the escape release before commissioning and thereafter once a year.

8.3 Actuator installation

8.3.1 Important information



WARNING!

Risk of injury due to loss of the safety function.

If the actuator PSEN ml DHM is installed incorrectly, the escape release handle may be accessible from the outside. This may mean that the guard locking is unlocked from the outside and the safety gate is opened, although the hazardous machine is switched on.

- The actuator should be installed so that the escape release handle is only accessible from inside the danger zone.

- ▶ The escape release handle must be clearly visible and must not be concealed.
- ▶ The PSEN ml with DHM can be installed on left and right-hinged swing gates within the protected and non-protected area.

For correct installation it's essential to comply with the distances shown in the diagram.

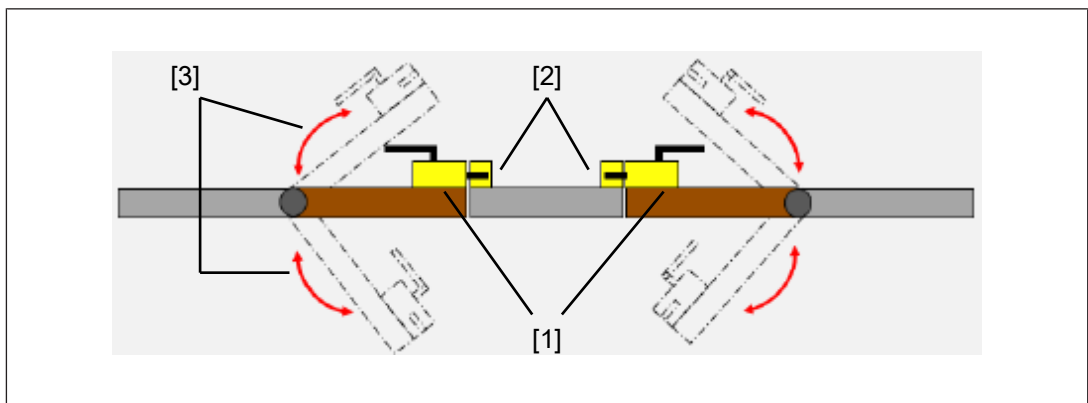

Legend

- [1] Swing gate with installed actuators
- [2] Vertical panel with installed safety switches
- [3] Gate's swing radius

- ▶ Gate's swing radius: min. 800 mm
- ▶ Cross section of gate profile: max. 60 mm
- ▶ Distance between safety switch and actuator: 5 ... 6 mm
- ▶ Installation is possible on left and right-hinged sliding gates within the protected and non-protected area.

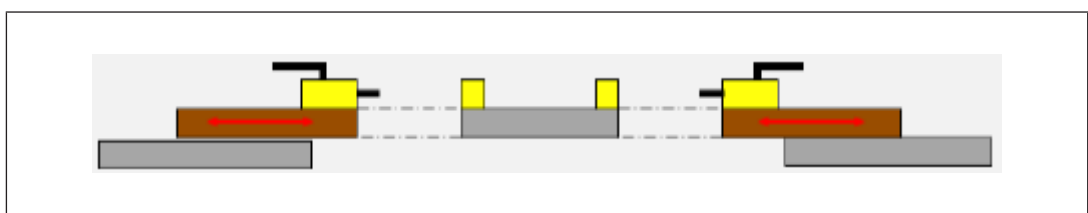

- ▶ Installation height of handle: 1.05 m ± 0.1 m
- ▶ Use an actuator for the respective cable outlet on the safety switch.
 - Upward cable outlet: PSEN ml up l/r x.x
 - Downward cable outlet: PSEN ml down l/r x.x

8.3.2 Install actuator on swing gate

Note that washers must be used when fastening M8 screws.

Actuator installed on mounting plate:

Drill holes (for M8 screws) in the mounting surface to secure the PSEN ml DHM mounting plate (see [Dimensions](#)  55).

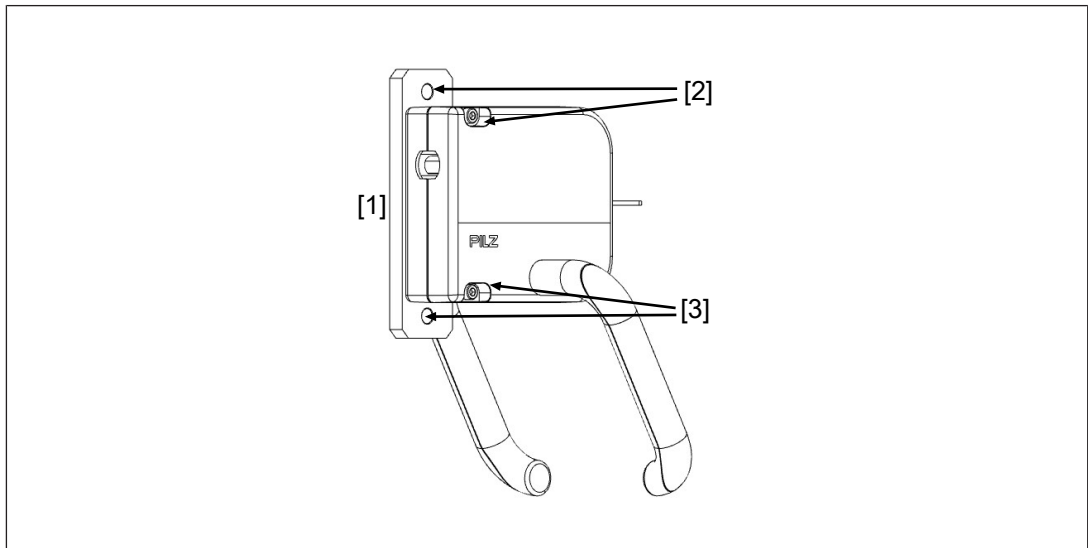

Legend

- [1] PSEN ml DHM mounting plate (see [Order reference](#)  70)
- [2] Holes for one-way screws
- [3] Holes for mounting screw

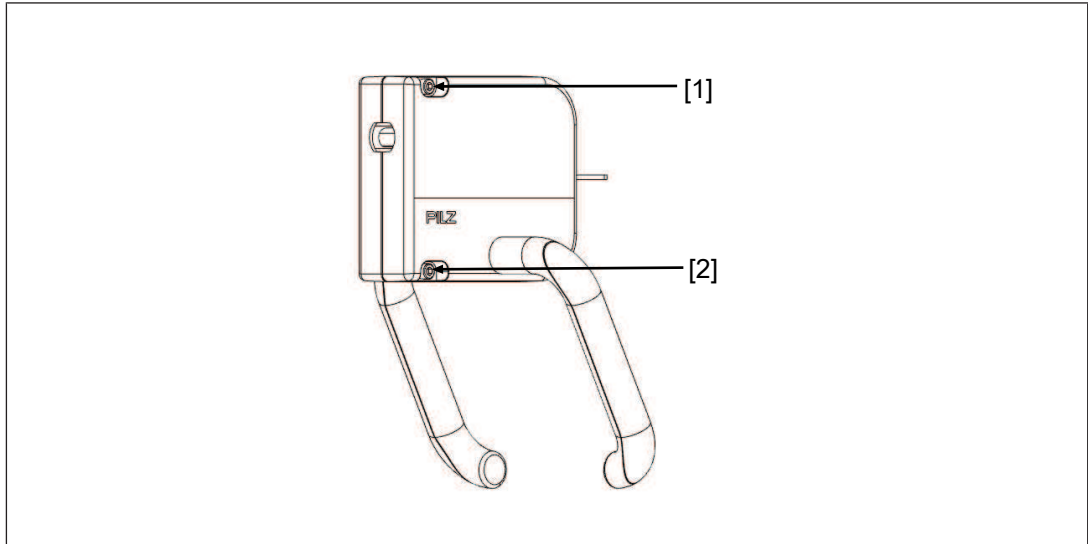

Actuator installed without mounting plate

Drill holes (for M5 screws) in the mounting surface to secure the actuator PSEN ml DHM (see [Dimensions](#) [ 53]).



Legend

- [1] Holes for one-way screws
- [2] Holes for mounting screws

1. Use two screws to fix the actuator in place.
2. Align the actuator to the safety switch.
The distance between safety switch and actuator must be 5 ... 6 mm.
3. Adjust the safety switch and actuator and carry out a function test (see [Adjustment](#) [ 47]).
Secure the safety switch and actuator and tighten the screws. Please note the max. torque setting stated in the [Technical details](#) [ 57].
4. Install the yellow/red PSEN ml DHM handle using the M5x20 mm fixing screws provided and secure the screw connections using a medium-strength threadlocker.
If you need to extend the handle with the PSEN ml DHM extension, use M5x45 mm or M5x70 mm fixing screws.
5. Apply the grip insert to the handle.
Use the red PSEN ml DHM handle with red grip insert for an escape release.
Use the yellow PSEN ml DHM handle with yellow grip insert for other applications.
To bridge larger distances the rotary handle can be further offset by 25 mm a maximum of twice (see [Order reference](#) [ 70]).

8.3.3 Install actuator on sliding gate

The PSEN ml DHM mounting flaps must be used to prevent lengthwise displacement.

Note that washers must be used when fastening M8 screws.

Actuator installed on mounting plate:

Provide drill holes (for M8 screws) in the mounting surface for securing the PSEN ml DHM mounting plate (see [Dimensions \[55\]](#)) and the PSEN ml DHM mounting flap (see [Dimensions \[56\]](#)).

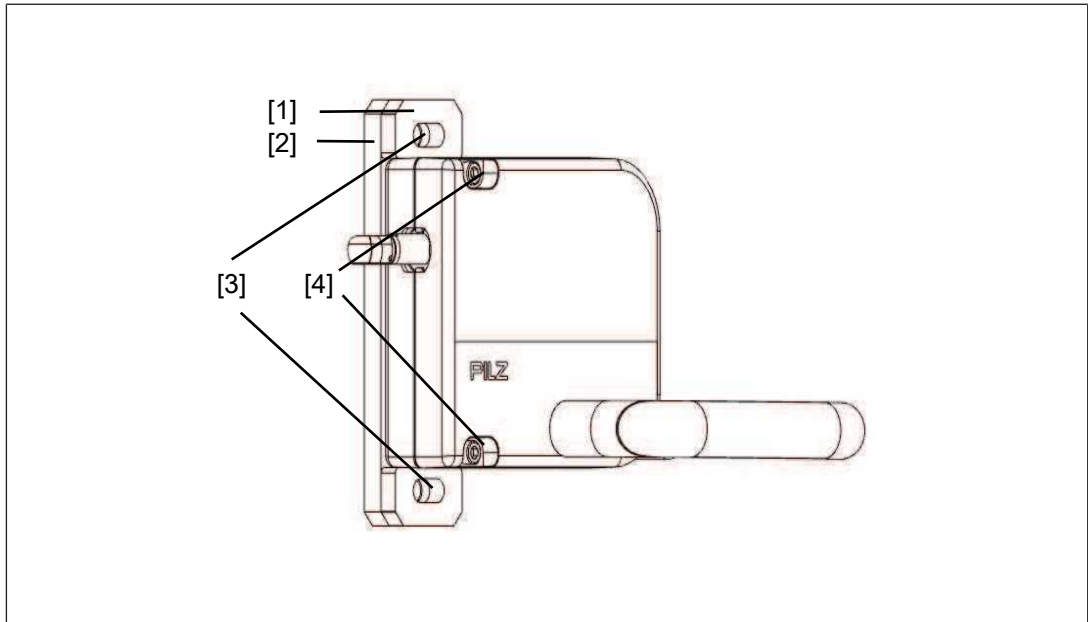

Legend

- [1] Mounting flap
- [2] Mounting plate
- [3] Drill holes (M8) for securing the mounting plate and mounting flap
- [4] Use M5 screws to secure the actuator

Actuator installed without mounting plate

Provide drill holes (for M5 screws) in the mounting surface for securing the actuator (see [Dimensions \[53\]](#)) and drill holes (for M8 screws) for securing the PSEN ml DHM mounting flap (see [Dimensions \[56\]](#)).

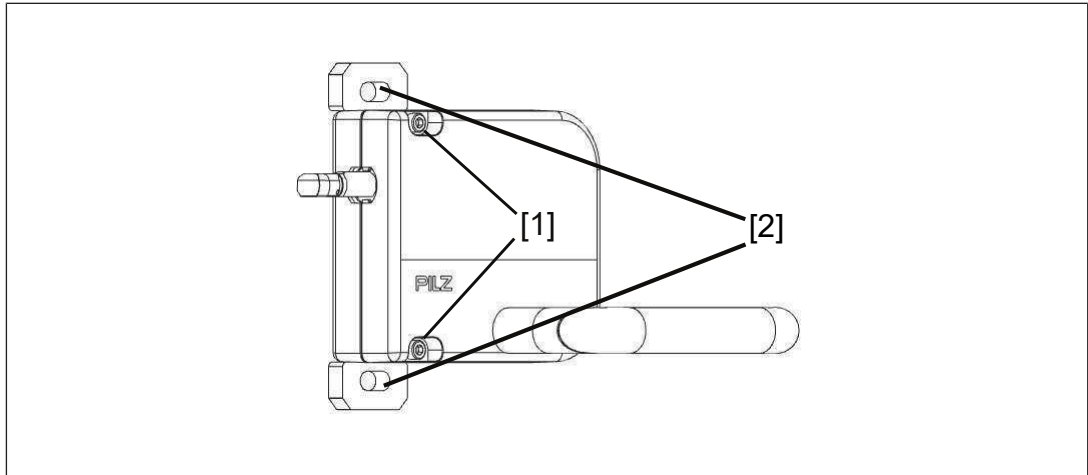

Legend

- [1] Drill holes (M5) for securing the actuator
- [2] Drill holes (M8) for securing the mounting flaps

1. Use two M8 screws (minimum length: 20 mm) to fix the mounting flaps in place. Use washers.
2. Use two M5 screws (minimum length: 40 mm) to fix the actuator in place.
3. Align the actuator to the safety switch.
The distance between safety switch and actuator must be 5 ... 6 mm.
4. Adjust the safety switch and actuator and carry out a function test (see [Adjustment \[47\]](#)).
Secure the safety switch and actuator and tighten the screws. Please note the max. torque setting stated in the [Technical details \[57\]](#).
5. Tighten the screws on the mounting flap and secure the screws using a medium-strength threadlocker.
6. Install the yellow/red PSEN ml DHM handle using the M5x20 mm fixing screws provided and secure the screw connections using a medium-strength threadlocker.
If you need to extend the handle with the PSEN ml DHM extension, use M5x45 mm or M5x70 mm fixing screws.
7. Apply the grip insert to the handle.
Use the red PSEN ml DHM handle with red grip insert for an escape release.
Use the yellow PSEN ml DHM handle with yellow grip insert for other applications.
To bridge larger distances the rotary handle can be further offset by 25 mm a maximum of twice (see [Order reference \[70\]](#)).

8.4 Escape release accessory

8.4.1 Important information

The escape release accessory may be installed outside the danger zone as an emergency release in accordance with EN ISO 14119.

- ▶ Prevent any unintended operation of the escape release.
- ▶ Prevent the effect of transverse forces on the escape release.
- ▶ Secure the screw connections with a medium-strength threadlocker.
- ▶ The button of the escape release pin must be clearly visible and must not be concealed.
- ▶ The mounting surface has to completely cover the bottom of the escape release housing. The bottom of the escape release housing must not be accessible after installation.

8.4.2 Installation positions for escape release

The stationary escape release can be installed on the three auxiliary releases in three different directions each.

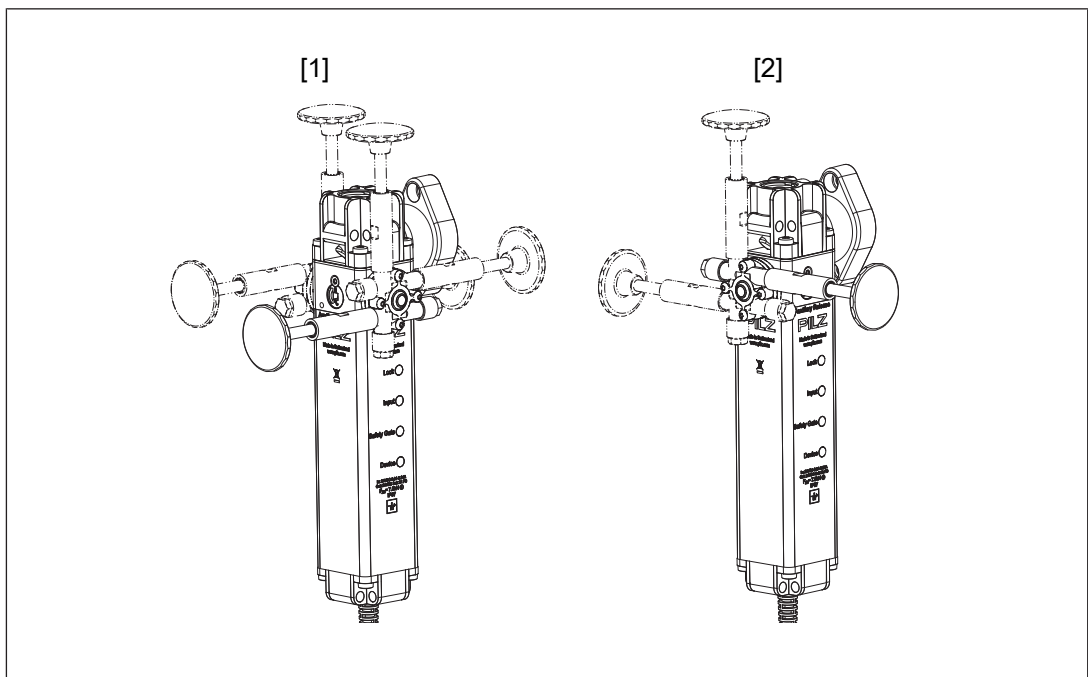

Legend

- [1] Installation options at the sides
- [2] Installation options at the back

8.4.3 Installation stationary escape release

1. Remove the security screw [1] using a Torx T10 screwdriver T10.
2. Screw the adapter disk of the escape release with the two hexagon sockets M3x8 [3] on the safety switch with 1,2 - 1,5 Nm (see diagram). The pin of the adapter disk [2] must be at the place where the security screw of the auxiliary release [1] used to be.

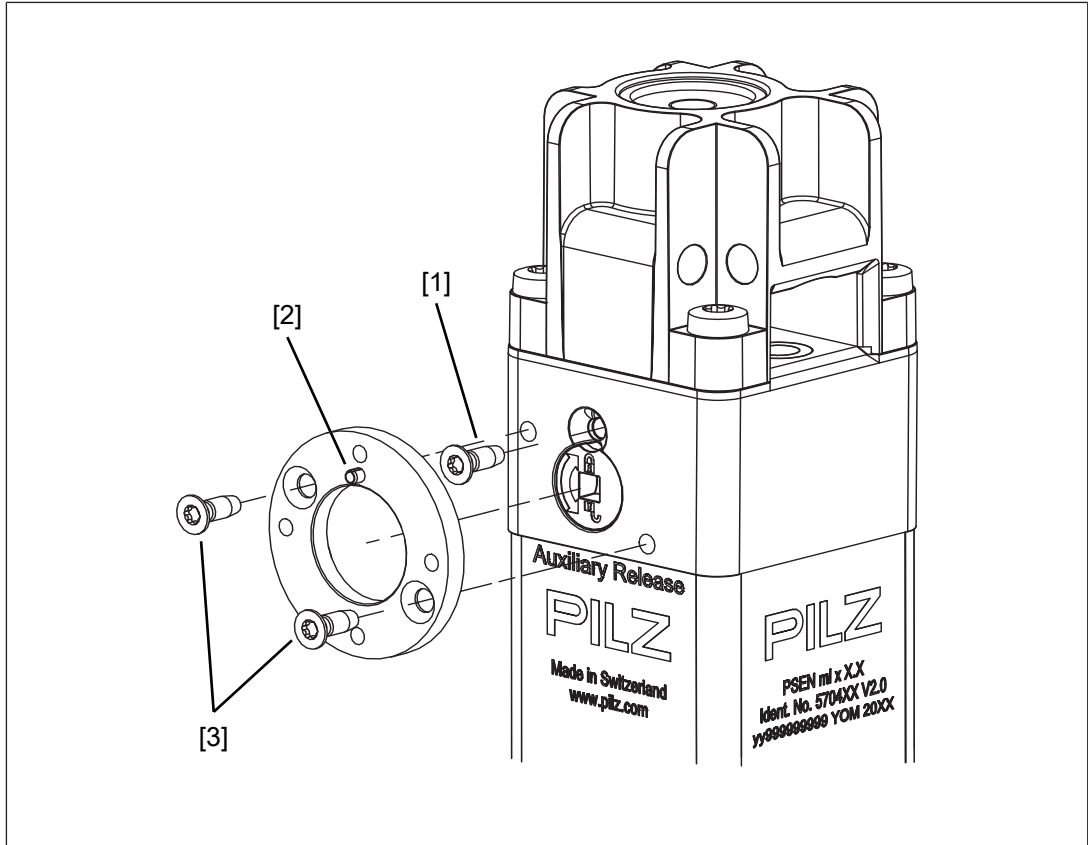

Legend

- [1] Security screw of the auxiliary release
- [2] Pin in the adapter disk
- [3] Hexagon sockets M3x8

3. Screw the escape release with the four raised head screws M3x12 to the adapter disk with 1,2 - 1,5 Nm (see diagram).
 - ▶ The button of the escape release pin can be removed for the installation (e.g. when the escape release pin is to be run through a wall). Once the installation of the escape release is complete, the button of the escape release pin must be secured again with a medium-strength threadlocker and hand-tightened
 - ▶ To bridge larger distances the escape release pin can be extended by a max. of 25 mm two times (see [Order reference: Accessories \[70\]](#)).

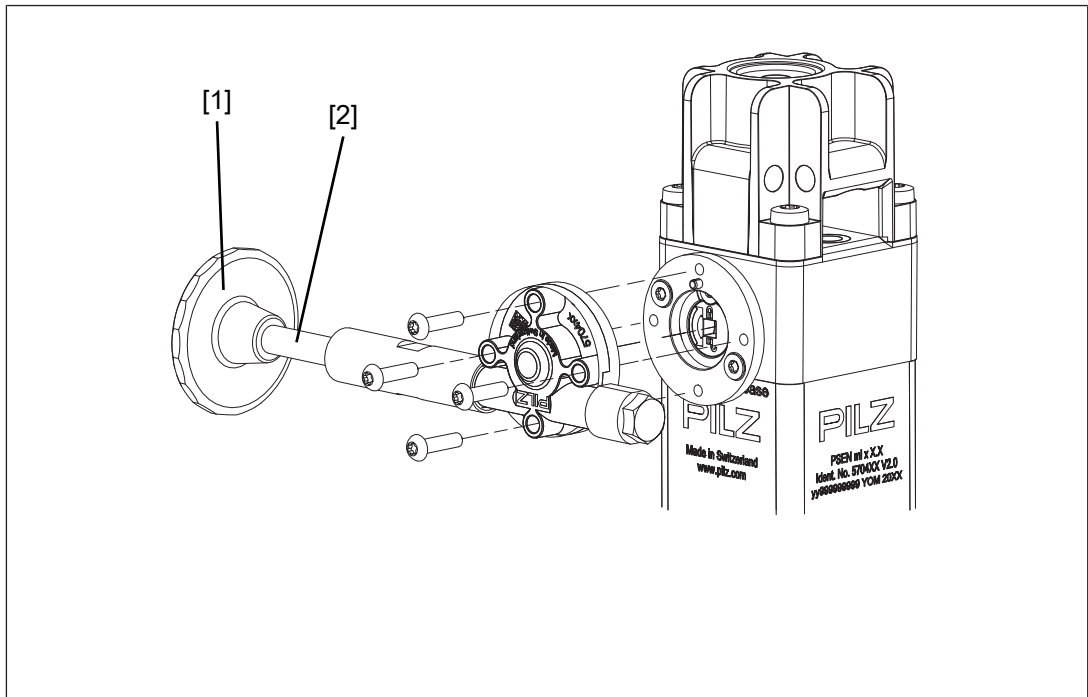

Legend

- [1] Button of the escape release pin
- [2] Escape release pin

9 Adjustment

After installation, check whether adjustment is necessary. To check this refer to the diagrams with the stated values for max. offset and correct if necessary.

- ▶ Always test the function with a connected evaluation device.
- ▶ Use a connected evaluation device to check the function of the escape release.
- ▶ Safety switch and actuator must be aligned correctly

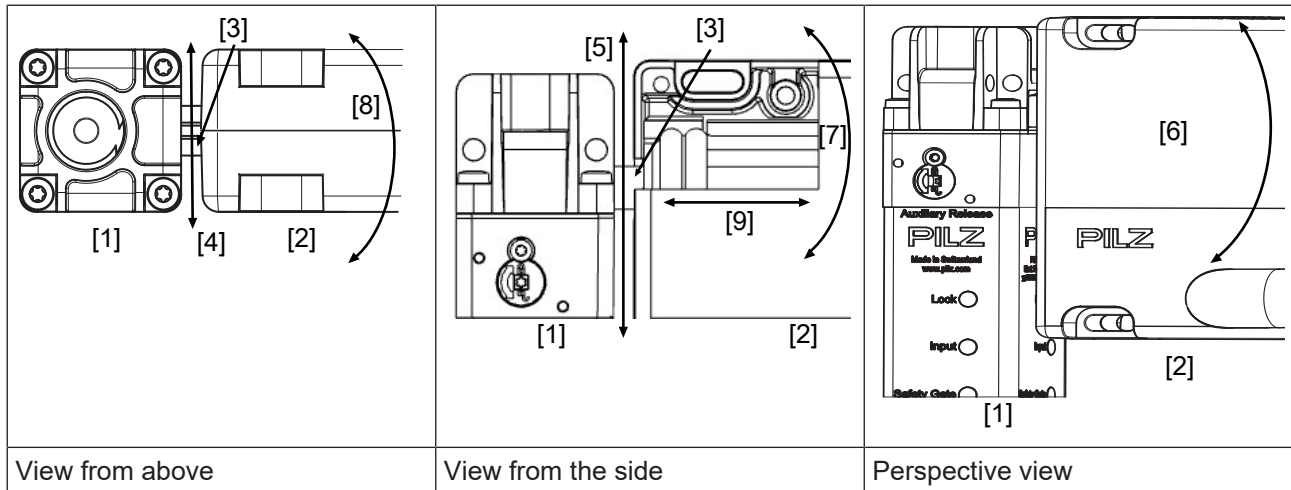

[1]	Safety switch	
[2]	Actuator	
[3]	Bolt in the actuator	
[4]	Max. lateral offset	+/-2.0 mm
[5]	Max. vertical offset	+/-2.0 mm
[6]	Max. angular offset around the X axis	+/-2.0 deg
[7]	Max. angular offset around the Y axis	+/-2.5 deg
[8]	Max. angular offset around the Z axis	+/-5.0 deg
[9]	Max. offset in closing direction	+/-5.0 mm

9.1 Attach safety switch and actuator

Once the safety switch and actuator are correctly aligned, the actuator's screw connection must be tightened.





Procedure:

1. Tighten up one M5 screw.
2. For applications with increased safety requirements (e.g. SIL CL 2 PL d), swap the second M5 screw for an M5 locking screw.
3. Tighten up the M5 screw or M5 locking screw.

Please note the max. torque setting stated in the [Technical details \[57\]](#).

10 Operation

Legend

	LED off
	LED on
	LED flashes (500 ms on, 500 ms off)
	LED flashes quickly (50 ms on, 950 ms off)
	LED flashes very quickly (25 ms on, 475 ms off)

Status indicators













- ▶ "Device" LED illuminates green: The unit is ready for operation
- ▶ "Safety Gate" LED lights up yellow: Actuator is within the response range
- ▶ "Lock" LED lights up green: Guard locking active
- ▶ "Input" LED lights up yellow: The unit is ready for operation







NOTICE











The safety function should be checked after initial commissioning and each time the plant/machine is changed. The safety functions may only be checked by qualified personnel.

10.1 Normal operation mlock











LED status				Switch status
Device	Safety Gate	Input	Lock	
 Green	 Yellow	 Yellow	 Green	The safety switch is started
 Green	 LED off	 Yellow	 LED off	Safety gate open, actuator not detected, guard locking deactivated
 Green	 Yellow	 Yellow	 LED off	Safety gate closed, actuator detected, guard locking deactivated

LED status				Switch status
Device	Safety Gate	Input	Lock	
 Green	 Yellow	 Yellow	 Green	Safety gate closed, actuator detected, guard locking activated

Warnings

LED status				Switch status	Remedy / measure
Device	Safety Gate	Input	Lock		
 Green	 Yellow	 Yellow	 Green	Safety gate closed, actuator detected, guard locking cannot be activated / deactivated	Check the actuator's alignment [ 47] to the safety switch.
				The supply voltage to safety inputs S31 and S41 was switched back on before the auxiliary release screw was turned back.	Turn back the auxiliary release screw and then switch the supply voltage on (see Recommissioning [ 21]).
 Green	Display not definitive	 Yellow	 Yellow	Guard locking pin is in an intermediate position	
 Yellow	Display not definitive	 Yellow	Display not definitive	Safety switch active despite over or undervoltage	Check the supply voltage. If safety inputs S31 and S41 are activated or deactivated while an undervoltage warning is present, the safety switch switches to a fault condition.

10.2 Error display

LED status				Switch status	Remedy / measure
Device	Safety Gate	Input	Lock		
 Red	 Yellow	 Yellow	Display not definitive	Safety switch deactivated due to under or over-voltage	Check the supply voltage and switch the supply voltage off and then on again.
 Red	Previous LED display is retained		Display not definitive	Safety outputs in fault condition	Check the wiring and switch the supply voltage off and then on again.
 Red			 Red	Auxiliary release/escape release activated	<ul style="list-style-type: none"> ▶ Auxiliary release: Turn back the auxiliary release screw and then switch the supply voltage on (see Recommissioning [📖 21]). ▶ Escape release: Pull the button of the escape release pin back again and then switch on the supply voltage again (see Recommissioning under escape release [📖 25]).
 Red	Display not definitive			Safety switch does not start	Change the safety switch.
 Green	 Yellow	Display not definitive	Display not definitive	Wrong actuator	Use only approved combinations (see Approved combinations [📖 12])

11 Checks and maintenance

It is not necessary to perform maintenance work on the product in normal operation. Please return any faulty products to Pilz.

Regular inspection of the switch function is required to guarantee the trouble-free, long-term function.

If the interlock and guard locking system is only used rarely (opening and closing the safety gate and activating/deactivating the guard locking device), a manual function test is required.

The correct function of the device should be checked at regular intervals and after each error.

Test intervals in accordance with EN ISO 14119:

- ▶ for SIL CL 3/PL e at least once per month
- ▶ for SIL CL 2/PL d at least every year

The Appendix contains a [Check list](#)  72], which should help you perform the test.

Visual inspection

- ▶ Check that the seal on the security screw on the auxiliary release is intact. If the seal is not intact, insert the security screw and use varnish to seal the security screw.
- ▶ Check the safety switch and actuator for damage.
- ▶ Check that the safety switch and actuator are firmly secured.
- ▶ Check the offset of the safety switch and actuator.
 - Max. lateral offset
 - Max. angular offset
 - Max. vertical offset
- ▶ Check the distance between safety switch and actuator.

This distance may be 5 ... 6 mm.
- ▶ Check that the wiring is correct.
- ▶ Remove any dirt from the safety switch and actuator.

Function test

- ▶ The actuator is detected and at the signal output/ diagnostic output Y32 there is a high signal after detection of the actuator.
- ▶ The guard locking device can be activated/deactivated when the safety inputs S31 and S41 are activated.
- ▶ Under these conditions there is a high signal at safety outputs 12 and 22:
 - The actuator is detected
 - Guard locking pin has successfully been activated (guard locking pin is in the locked position)

If one of these conditions is not met, the signal at the safety outputs will be low.

Escape release

- ▶ Check that the handle for the escape release is recognisable and accessible.
- ▶ Check the function of the escape release before commissioning and thereafter once a year.

12 Dimensions

Safety switch

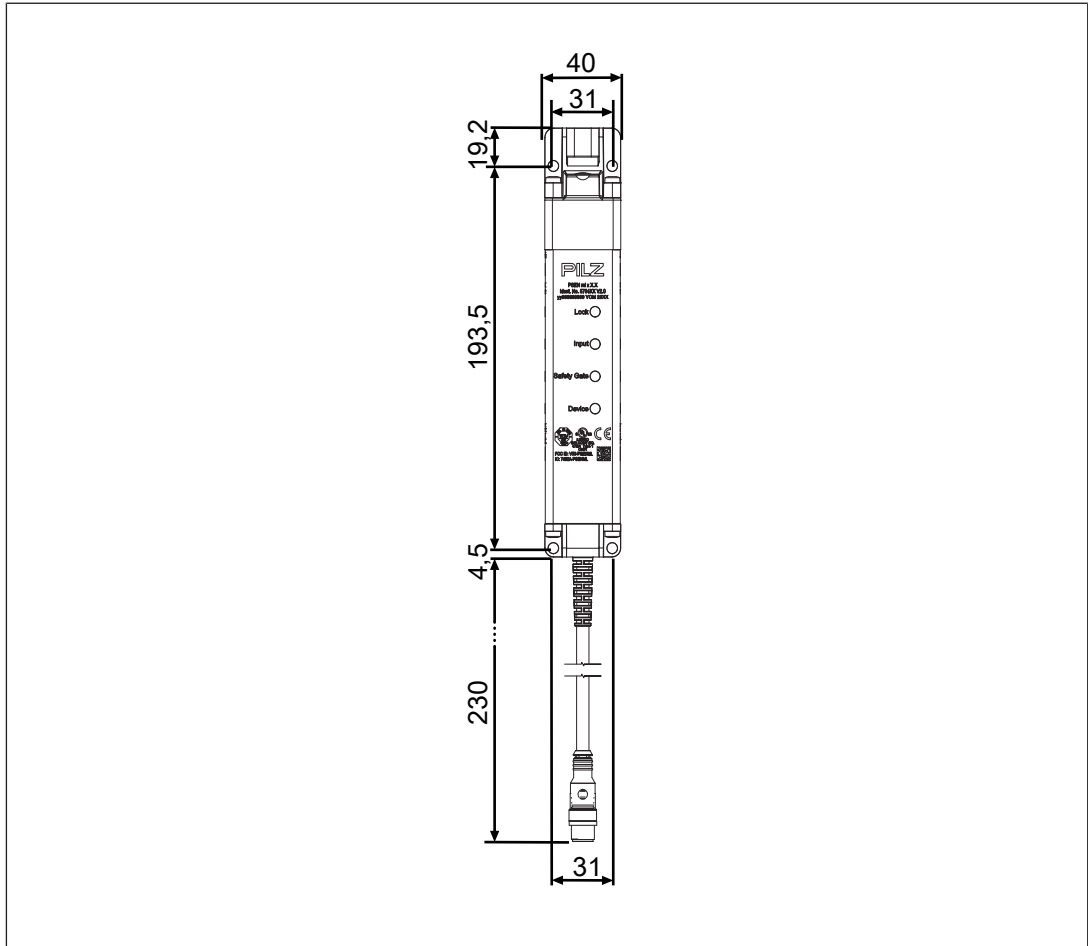

Actuator

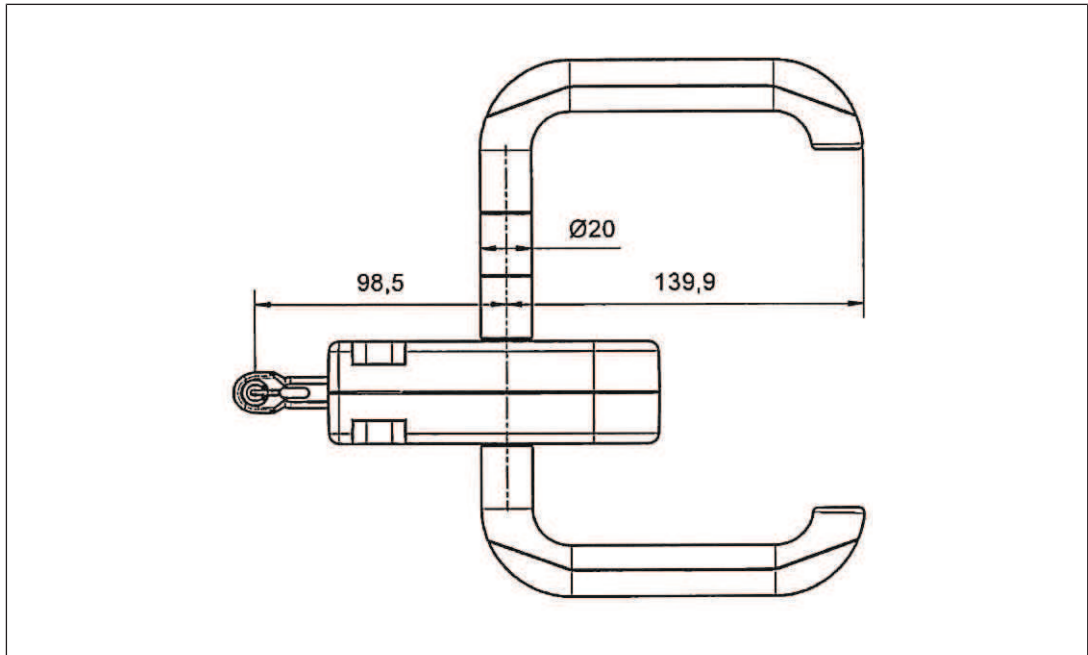

Fig.: Plan view

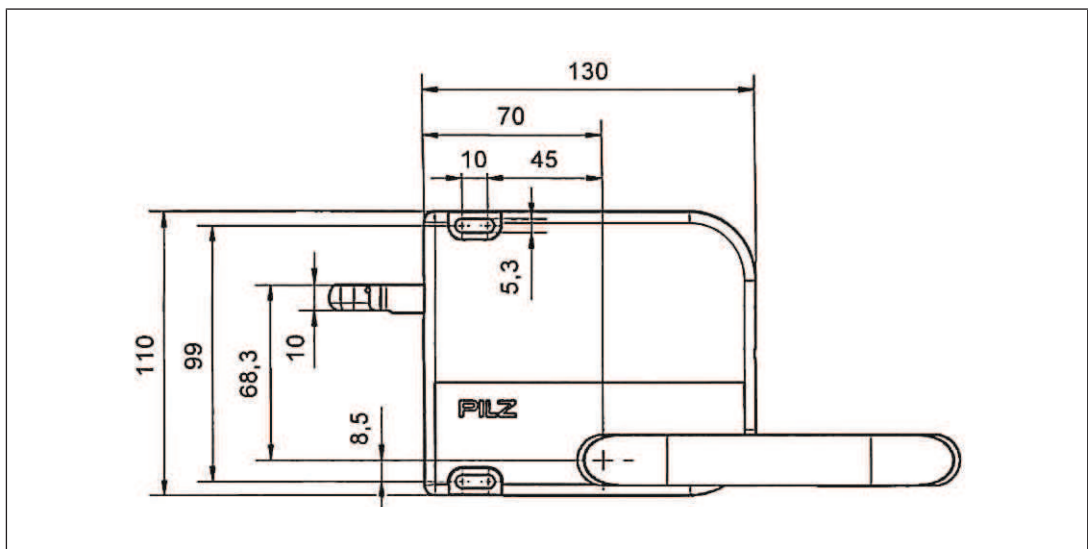

Fig.: Front view

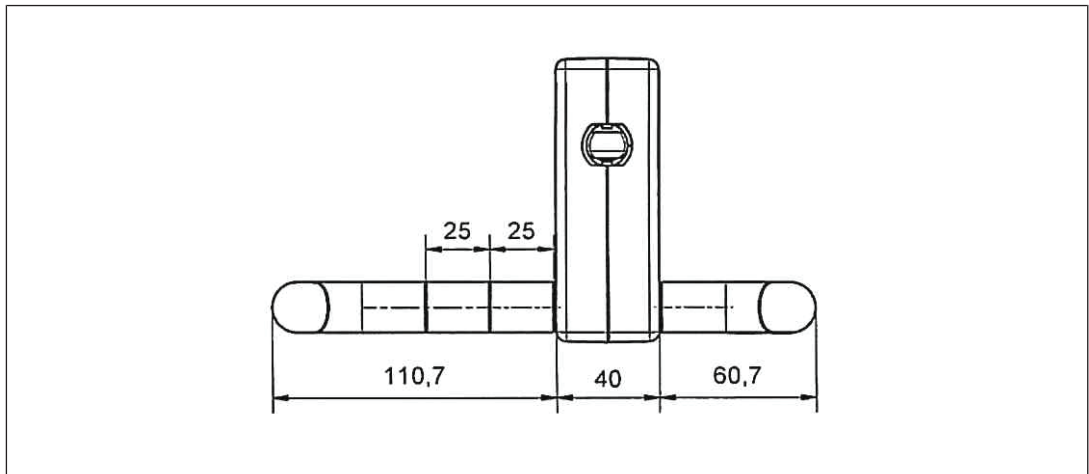

Fig.: Side view

Mounting plate (see [Accessories \[70\]](#))

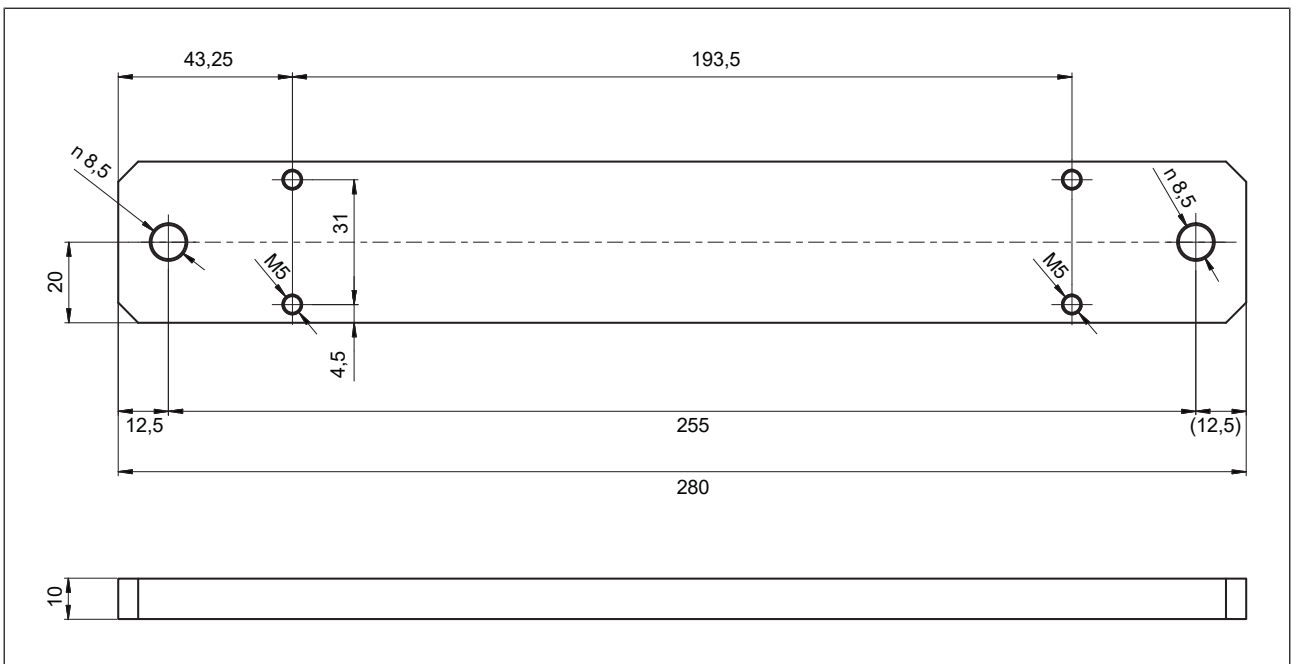

Fig.: Order no.: 570490

Mounting plate for PSEN ml DHM (see [Accessories \[70\]](#))

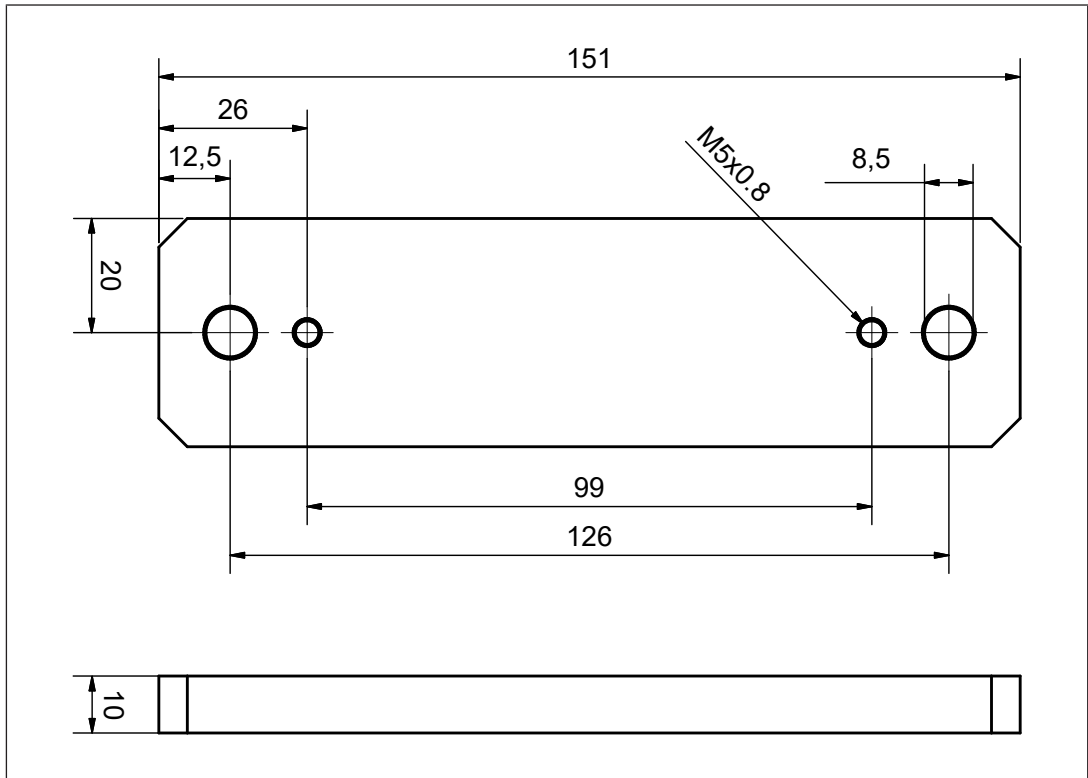
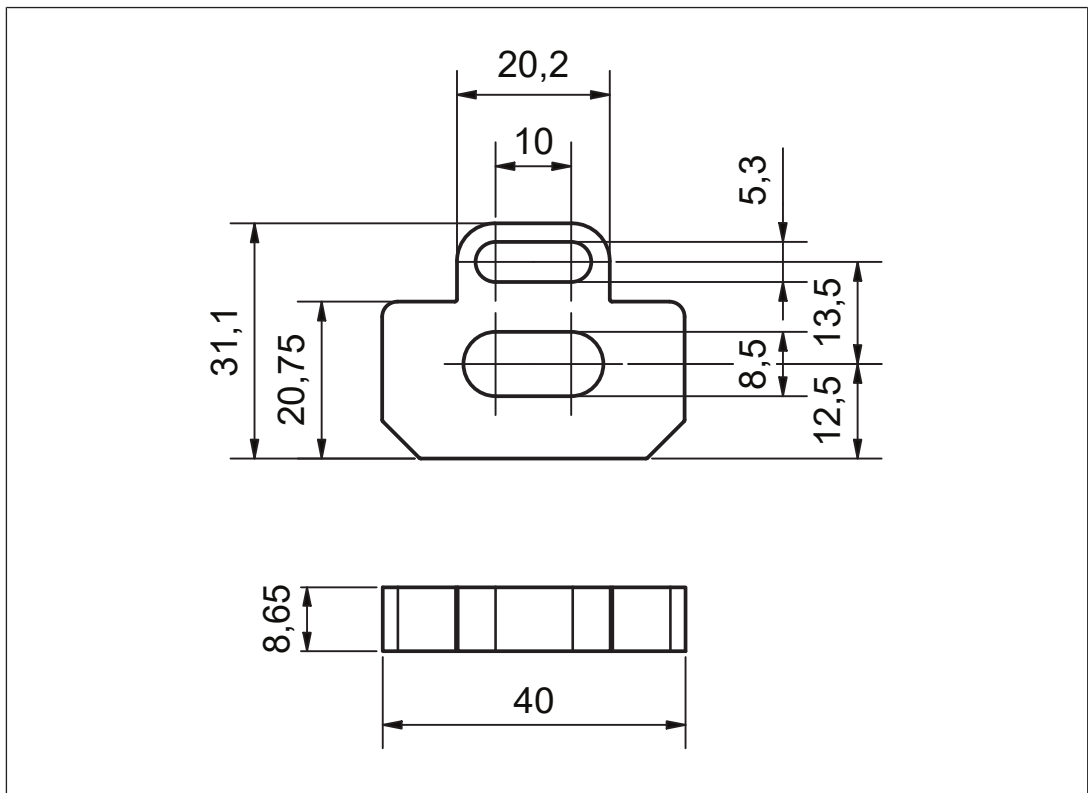

Fig.: Order no.: 60000013

Dimensions of mounting flap for PSEN ml DHM



13 Technical details for safety switch

General	570401	570403	570405
Certifications	CE, FCC, IC, TÜV, cULus Listed	CE, FCC, IC, TÜV, cULus Listed	CE, FCC, IC, TÜV, cULus Listed
Sensor's mode of operation	Transponder	Transponder	Transponder
Coding level in accordance with EN ISO 14119	Low	High	High
Design in accordance with EN ISO 14119	4	4	4
Classification in accordance with EN 60947-5-3	PDDB	PDDB	PDDB
Pilz coding type	Coded	fully coded	uniquely coded
Transponder	570401	570403	570405
Frequency band	122 kHz - 128 kHz	122 kHz - 128 kHz	122 kHz - 128 kHz
Max. transmitter output	15 mW	15 mW	15 mW
Electrical data	570401	570403	570405
Supply voltage			
Voltage	24 V	24 V	24 V
Kind	DC	DC	DC
Voltage tolerance	-20 %/+20 %	-20 %/+20 %	-20 %/+20 %
Output of external power supply (DC)	1 W	1 W	1 W
Max. switching frequency	1 Hz	1 Hz	1 Hz
Magnet. supply voltage	24 V	24 V	24 V
Max. solenoid current t <150 ms	1 A	1 A	1 A
Max. cable capacitance at the safety outputs			
No-load, PNOZ with relay contacts	40 nF	40 nF	40 nF
PNOZmulti, PNOZelog, PSS	70 nF	70 nF	70 nF
Max. inrush current impulse			
Current pulse, A1	5 A	5 A	5 A
Pulse duration, A1	0,0002 ms	0,0002 ms	0,0002 ms
Max. unit fuse protection in accordance with UL	3 A	3 A	3 A
No-load current	40 mA	40 mA	40 mA
Inputs	570401	570403	570405
Number	2	2	2
Voltage at inputs	24 V DC	24 V DC	24 V DC
Current at solenoid input	500 mA	500 mA	500 mA

Semiconductor outputs	570401	570403	570405
Number of OSSD safety outputs	2	2	2
Signal outputs	1	1	1
Switching current per output	100 mA	100 mA	100 mA
Breaking capacity per output	2,4 W	2,4 W	2,4 W
Potential isolation from system voltage	No	No	No
Short circuit-proof	yes	yes	yes
Residual current at outputs	100 µA	100 µA	100 µA
Voltage drop at OSSDs	1 V	1 V	1 V
Conditional rated short circuit current	100 A	100 A	100 A
Lowest operating current	1 mA	1 mA	1 mA
Utilisation category in accordance with EN 60947-1	DC-13	DC-13	DC-13
Times	570401	570403	570405
Test pulse duration, safety outputs	450 µs	450 µs	450 µs
Switch-on delay			
after UB is applied	1,1 s	1,1 s	1,1 s
Actuator typ.	30 ms	30 ms	30 ms
Actuator max.	50 ms	50 ms	50 ms
Delay-on de-energisation			
Actuator typ.	30 ms	30 ms	30 ms
Actuator max.	40 ms	40 ms	40 ms
Risk time in accordance with EN 60947-5-3	260 ms	260 ms	260 ms
Supply interruption before de-energisation	20 ms	20 ms	20 ms
Simultaneity, channel 1 and 2 max.	20 ms	20 ms	20 ms
Pulse duration Lock/Unlock Request	350 - 400 ms	350 - 400 ms	350 - 400 ms
Processing time activate/deactivate guard locking	100 ms	100 ms	100 ms
Environmental data	570401	570403	570405
Temperature of metal surface at ambient temperature: 25 °C	40 °C	40 °C	40 °C
Ambient temperature			
In accordance with the standard	EN 60068-2-14	EN 60068-2-14	EN 60068-2-14
Temperature range	0 - 60 °C	0 - 60 °C	0 - 60 °C

Environmental data	570401	570403	570405
Storage temperature			
In accordance with the standard	EN 60068-2-1/-2	EN 60068-2-1/-2	EN 60068-2-1/-2
Temperature range	-25 - 70 °C	-25 - 70 °C	-25 - 70 °C
Climatic suitability			
In accordance with the standard	EN 60068-2-78	EN 60068-2-78	EN 60068-2-78
Humidity	93 % r. h. at 40 °C	93 % r. h. at 40 °C	93 % r. h. at 40 °C
EMC	EN 55011: class A, EN 60947-5-3, EN 61326-3-1	EN 55011: class A, EN 60947-5-3, EN 61326-3-1	EN 55011: class A, EN 60947-5-3, EN 61326-3-1
Vibration			
In accordance with the standard	EN 60068-2-6	EN 60068-2-6	EN 60068-2-6
Frequency	10 - 55 Hz	10 - 55 Hz	10 - 55 Hz
Amplitude	1 mm	1 mm	1 mm
Shock stress			
In accordance with the standard	EN 60068-2-27	EN 60068-2-27	EN 60068-2-27
Number of shocks	3	3	3
Acceleration	30g	30g	30g
Duration	11 ms	11 ms	11 ms
Airgap creepage			
Overvoltage category	III	III	III
Pollution degree	3	3	3
Rated insulation voltage	75 V	75 V	75 V
Rated impulse withstand voltage	0,8 kV	0,8 kV	0,8 kV
Protection type			
Housing	IP67	IP67	IP67
In accordance with UL	Type 1	Type 1	Type 1
Mechanical data	570401	570403	570405
Length of cable with connector	230 mm	230 mm	230 mm
Min. bending radius (fixed permanently) K1	5 x Ø	5 x Ø	5 x Ø
Min. bending radius (moving) K1	10 x Ø	10 x Ø	10 x Ø
Cable diameter K1	6,2 mm	6,2 mm	6,2 mm
Escape release available	No	No	No
Mechanical life	1,000,000 cycles	1,000,000 cycles	1,000,000 cycles
Mechanical life with centering ring	50,000 cycles	50,000 cycles	50,000 cycles
Latching force	30 N	30 N	30 N
Retention force	20 - 40 N	20 - 40 N	20 - 40 N
Max. retract speed of actuator	0,3 m/s	0,3 m/s	0,3 m/s
Actuator 1	PSEN ml 1.1	PSEN ml 2.1	PSEN ml 2.1

Mechanical data	570401	570403	570405
Min. distance between safety switches	0 mm	0 mm	0 mm
Connection type	M12, 8-pin male connector	M12, 8-pin male connector	M12, 8-pin male connector
Cable	LiYY 8 x 0.25 mm²	LiYY 8 x 0.25 mm²	LiYY 8 x 0.25 mm²
Material	Aluminium, stainless steel, plastic, galvanised steel, Zn	Aluminium, stainless steel, plastic, galvanised steel, Zn	Aluminium, stainless steel, plastic, galvanised steel, Zn
Max. torque setting for fixing screws	6 - 6,5 Nm	6 - 6,5 Nm	6 - 6,5 Nm
Max. torque setting escape release	1,2 - 1,5 Nm	1,2 - 1,5 Nm	1,2 - 1,5 Nm
Max. torque setting for mounting plate	22 - 24 Nm	22 - 24 Nm	22 - 24 Nm
Max. torque setting for mounting bracket	14 - 16 Nm	14 - 16 Nm	14 - 16 Nm
Min. gate radius	300 mm	300 mm	300 mm
Dimensions			
Height	217,2 mm	217,2 mm	217,2 mm
Width	40 mm	40 mm	40 mm
Depth	40 mm	40 mm	40 mm
Weight of safety switch	950 g	950 g	950 g
Weight	950 g	950 g	950 g

Where standards are undated, the 2015-11 latest editions shall apply.

14 Technical details for actuator, order no. 6O000001-6O000004

General	6O000001	6O000002	6O000003	6O000004
Certifications	CE, TÜV, cULus Listed	CE, TÜV, cULus Listed	CE, TÜV, cULus Listed	CE, TÜV, cULus Listed
Sensor's mode of operation	Transponder	Transponder	Transponder	Transponder
Coding level in accordance with EN ISO 14119	Low	High	Low	High
Design in accordance with EN ISO 14119	4	4	4	4
Pilz coding type	Coded	fully coded	Coded	fully coded
Environmental data	6O000001	6O000002	6O000003	6O000004
Temperature of metal surface at ambient temperature: 25 °C	40 °C	40 °C	40 °C	40 °C
Ambient temperature				
In accordance with the standard	EN 60068-2-14	EN 60068-2-14	EN 60068-2-14	EN 60068-2-14
Temperature range	0 - 60 °C	0 - 60 °C	0 - 60 °C	0 - 60 °C
Storage temperature				
In accordance with the standard	EN 60068-2-1/-2	EN 60068-2-1/-2	EN 60068-2-1/-2	EN 60068-2-1/-2
Temperature range	-25 - 70 °C	-25 - 70 °C	-25 - 70 °C	-25 - 70 °C
Climatic suitability				
In accordance with the standard	EN 60068-2-78	EN 60068-2-78	EN 60068-2-78	EN 60068-2-78
Humidity	93 % r. h. at 40 °C	93 % r. h. at 40 °C	93 % r. h. at 40 °C	93 % r. h. at 40 °C
EMC	EN 55011: class A, EN 60947-5-3, EN 61326-3-1	EN 55011: class A, EN 60947-5-3, EN 61326-3-1	EN 55011: class A, EN 60947-5-3, EN 61326-3-1	EN 55011: class A, EN 60947-5-3, EN 61326-3-1
Vibration				
In accordance with the standard	EN 60068-2-6	EN 60068-2-6	EN 60068-2-6	EN 60068-2-6
Frequency	10 - 55 Hz	10 - 55 Hz	10 - 55 Hz	10 - 55 Hz
Amplitude	1 mm	1 mm	1 mm	1 mm
Shock stress				
In accordance with the standard	EN 60947-5-2	EN 60947-5-2	EN 60947-5-2	EN 60947-5-2
Number of shocks	6	6	6	6
Acceleration	10g	10g	10g	10g
Duration	11 ms	11 ms	11 ms	11 ms

Environmental data	6O000001	6O000002	6O000003	6O000004
Protection type				
Housing	IP20	IP20	IP20	IP20
In accordance with UL	Type 1	Type 1	Type 1	Type 1
Mechanical data	6O000001	6O000002	6O000003	6O000004
Service life escape release	6050 cycles	6050 cycles	6050 cycles	6050 cycles
Mechanical life	250,000 cycles	250,000 cycles	250,000 cycles	250,000 cycles
Holding force FZh				
on sliding gates (installed with mounting lug)	2000 N	2000 N	2000 N	2000 N
on swing gates:	3000 N	3000 N	3000 N	3000 N
Holding force F1Max in accordance with ISO 14119				
on sliding gates (installed with mounting lug)	4000 N	4000 N	4000 N	4000 N
on swing gates:	6000 N	6000 N	6000 N	6000 N
Max. vertical offset	+/-2,0 mm	+/-2,0 mm	+/-2,0 mm	+/-2,0 mm
Max. lateral offset	+/-2,0 mm	+/-2,0 mm	+/-2,0 mm	+/-2,0 mm
Max. angular offset around the X axis	+/-2,0 deg	+/-2,0 deg	+/-2,0 deg	+/-2,0 deg
Max. angular offset around the Y axis	+/-2,5 deg	+/-2,5 deg	+/-2,5 deg	+/-2,5 deg
Max. angular offset around the Z axis	+/-5,0 deg	+/-5,0 deg	+/-5,0 deg	+/-5,0 deg
Max. offset in closing direction	+/-5,0 mm	+/-5,0 mm	+/-5,0 mm	+/-5,0 mm
Max. retract speed of actuator	0,3 m/s	0,3 m/s	0,3 m/s	0,3 m/s
Material	Stainless steel, plastic, Zn	Stainless steel, plastic, Zn	Stainless steel, plastic, Zn	Stainless steel, plastic, Zn
Max. torque setting for fixing screws	6 Nm	6 Nm	6 Nm	6 Nm
Max. torque setting for mounting plate	22 - 24 Nm	22 - 24 Nm	22 - 24 Nm	22 - 24 Nm
Max. torque setting for rotary handle	6 - 6,5 Nm	6 - 6,5 Nm	6 - 6,5 Nm	6 - 6,5 Nm
Min. gate radius	800 mm	800 mm	800 mm	800 mm
Actuator dimensions				
Height	130 mm	130 mm	130 mm	130 mm
Width	110 mm	110 mm	110 mm	110 mm
Depth	40 mm	40 mm	40 mm	40 mm
Weight of actuator	2.050 g	2.050 g	2.050 g	2.050 g
Weight	2.050 g	2.050 g	2.050 g	2.050 g

Where standards are undated, the 2015-11 latest editions shall apply.

15 Technical details for actuator, order no. 6O000005-6O000008

General	6O000005	6O000006	6O000007	6O000008
Certifications	CE, TÜV, cULus Listed	CE, TÜV, cULus Listed	CE, TÜV, cULus Listed	CE, TÜV, cULus Listed
Sensor's mode of operation	Transponder	Transponder	Transponder	Transponder
Coding level in accordance with EN ISO 14119	Low	High	Low	High
Design in accordance with EN ISO 14119	4	4	4	4
Pilz coding type	Coded	fully coded	Coded	fully coded
Environmental data	6O000005	6O000006	6O000007	6O000008
Temperature of metal surface at ambient temperature: 25 °C	40 °C	40 °C	40 °C	40 °C
Ambient temperature				
In accordance with the standard	EN 60068-2-14	EN 60068-2-14	EN 60068-2-14	EN 60068-2-14
Temperature range	0 - 60 °C	0 - 60 °C	0 - 60 °C	0 - 60 °C
Storage temperature				
In accordance with the standard	EN 60068-2-1/-2	EN 60068-2-1/-2	EN 60068-2-1/-2	EN 60068-2-1/-2
Temperature range	-25 - 70 °C	-25 - 70 °C	-25 - 70 °C	-25 - 70 °C
Climatic suitability				
In accordance with the standard	EN 60068-2-78	EN 60068-2-78	EN 60068-2-78	EN 60068-2-78
Humidity	93 % r. h. at 40 °C	93 % r. h. at 40 °C	93 % r. h. at 40 °C	93 % r. h. at 40 °C
EMC	EN 55011: class A, EN 60947-5-3, EN 61326-3-1	EN 55011: class A, EN 60947-5-3, EN 61326-3-1	EN 55011: class A, EN 60947-5-3, EN 61326-3-1	EN 55011: class A, EN 60947-5-3, EN 61326-3-1
Vibration				
In accordance with the standard	EN 60068-2-6	EN 60068-2-6	EN 60068-2-6	EN 60068-2-6
Frequency	10 - 55 Hz	10 - 55 Hz	10 - 55 Hz	10 - 55 Hz
Amplitude	1 mm	1 mm	1 mm	1 mm
Shock stress				
In accordance with the standard	EN 60947-5-2	EN 60947-5-2	EN 60947-5-2	EN 60947-5-2
Number of shocks	6	6	6	6
Acceleration	10g	10g	10g	10g
Duration	11 ms	11 ms	11 ms	11 ms

Environmental data	6O000005	6O000006	6O000007	6O000008
Protection type				
Housing	IP20	IP20	IP20	IP20
In accordance with UL	Type 1	Type 1	Type 1	Type 1
Mechanical data	6O000005	6O000006	6O000007	6O000008
Service life escape release	6050 cycles	6050 cycles	6050 cycles	6050 cycles
Mechanical life	250,000 cycles	250,000 cycles	250,000 cycles	250,000 cycles
Holding force FZh				
on sliding gates (installed with mounting lug)	2000 N	2000 N	2000 N	2000 N
on swing gates:	3000 N	3000 N	3000 N	3000 N
Holding force F1Max in accordance with ISO 14119				
on sliding gates (installed with mounting lug)	4000 N	4000 N	4000 N	4000 N
on swing gates:	6000 N	6000 N	6000 N	6000 N
Max. vertical offset	+/-2,0 mm	+/-2,0 mm	+/-2,0 mm	+/-2,0 mm
Max. lateral offset	+/-2,0 mm	+/-2,0 mm	+/-2,0 mm	+/-2,0 mm
Max. angular offset around the X axis	+/-2,0 deg	+/-2,0 deg	+/-2,0 deg	+/-2,0 deg
Max. angular offset around the Y axis	+/-2,5 deg	+/-2,5 deg	+/-2,5 deg	+/-2,5 deg
Max. angular offset around the Z axis	+/-5,0 deg	+/-5,0 deg	+/-5,0 deg	+/-5,0 deg
Max. offset in closing direction	+/-5,0 mm	+/-5,0 mm	+/-5,0 mm	+/-5,0 mm
Max. retract speed of actuator	0,3 m/s	0,3 m/s	0,3 m/s	0,3 m/s
Material	Stainless steel, plastic, Zn	Stainless steel, plastic, Zn	Stainless steel, plastic, Zn	Stainless steel, plastic, Zn
Max. torque setting for fixing screws	6 Nm	6 Nm	6 Nm	6 Nm
Max. torque setting for mounting plate	22 - 24 Nm	22 - 24 Nm	22 - 24 Nm	22 - 24 Nm
Max. torque setting for rotary handle	6 - 6,5 Nm	6 - 6,5 Nm	6 - 6,5 Nm	6 - 6,5 Nm
Min. gate radius	800 mm	800 mm	800 mm	800 mm
Actuator dimensions				
Height	130 mm	130 mm	130 mm	130 mm
Width	110 mm	110 mm	110 mm	110 mm
Depth	40 mm	40 mm	40 mm	40 mm
Weight of actuator	2.050 g	2.050 g	2.050 g	2.050 g
Weight	2.050 g	2.050 g	2.050 g	2.050 g

Where standards are undated, the 2015-11 latest editions shall apply.

16 Technical details for escape release 570460

General	570460
Certifications	CE

Mechanical data	570460
Release force escape release	80 N
Service life escape release	6050 cycles
Weight	115 g

17 Classification according to ZVEI, CB24I

The following tables describe the classes and specific values of the product interface and the classes of interfaces compatible with it. The classification is described in the ZVEI position paper "Classification of Binary 24 V Interfaces - Functional Safety aspects covered by dynamic testing".

Solenoid inputs

Drain		Source	
Safety switch	C2	Safety control system	C2, C3

Drain parameters	Min.	Typ.	Max.
Test impulse duration	-	-	500 µs
Input resistance	16 Ohm	-	
Capacitive load	-	-	1,5 nF

Safe 1-pole HL outputs

Source		Drain	
Safety switch	C2	Evaluation device	C1, C2

Source parameters	Min.	Typ.	Max.
Test impulse duration	-	-	450 µs
Rated current	-	-	0,1 A
Capacitive load	-	-	70 nF

18 Safety characteristic data



NOTICE

You must comply with the safety characteristic data in order to achieve the required safety level for your plant/machine.

Operating mode	EN ISO 13849-1: 2015 PL	EN ISO 13849-1: 2015 Category	EN IEC 62061 SIL CL	EN IEC 62061 PFH _D [1/h]	Lambda d/ Lambda	EN ISO 13849-1: 2015, EN IEC B10D	EN ISO 13849-1: 2015 T _M [year]
1-ch. guard locking	PL d	Cat. 2	SIL CL 2	2,54E-08	–	6,08E-05	20
2-ch. guard locking	PL e	Cat. 4	SIL CL 3	2,54E-08	–	6,08E-05	20
2-ch. OSSD	PL e	Cat. 4	SIL CL 3	1,90E-08	–	–	20
Escape re-release		Cat B					20

Explanatory notes for the safety-related characteristic data:

- ▶ The SIL CL value in accordance with EN 62061 corresponds to the SIL value in accordance with EN 61508.
- ▶ T_M is the maximum mission time in accordance with EN ISO 13849-1. The value also applies as the retest interval in accordance with EN 61508-6 and IEC 61511 and as the proof test interval and mission time in accordance with EN 62061.

All the units used within a safety function must be considered when calculating the safety characteristic data.



INFORMATION

A safety function's SIL/PL values are **not** identical to the SIL/PL values of the units that are used and may be different. We recommend that you use the PASCAL software tool to calculate the safety function's SIL/PL values.



NOTICE

Be sure that you observe the mechanical life. The safety characteristic data are only valid as long as the values of mechanical life are met.

19 Supplementary data

19.1 Radio approval

USA/Canada

FC FCC ID: VT8-PSENML
IC: 7482A-PSENML

FCC/IC-Requirements:

This product complies with Part 15 of the FCC Rules and with Industry Canada licence-exempt RSS standards.

Operation is subject to the following two conditions:

- 1) this product may not cause harmful interference, and
- 2) this product must accept any interference received, including interference that may cause undesired operation.

Changes or modifications made to this product not expressly approved by Pilz may void the FCC authorization to operate this equipment.

NOTE: This equipment has been tested and found to comply with the limits for a Class A digital device, pursuant to Part 15 of the FCC Rules. These limits are designed to provide reasonable protection against harmful interference when the equipment is operated in a commercial environment. This equipment generates, uses, and can radiate radio frequency energy and, if not installed and used in accordance with the instruction manual, may cause harmful interference to radio communications. Operation of this equipment in a residential area is likely to cause harmful interference in which case the user will be required to correct the interference at his own expense.

Le présent produit est conforme aux CNR d'Industrie Canada applicables aux appareils radio exempts de licence. L'exploitation est autorisée aux deux conditions suivantes:

- (1) le produit ne doit pas produire de brouillage, et
- (2) l'utilisateur de le produit doit accepter tout brouillage radioélectrique subi, même si le brouillage est susceptible d'en compromettre le fonctionnement.

20 Order reference

20.1 System

Product type	Features		Order no.
PSEN ml b 1.1 switch	Mechanical safety switch with guard locking, coded, for single connection	8-pin M12 connector	570401
PSEN ml b 2.1 switch	Mechanical safety switch with guard locking, fully coded, for single connection	8-pin M12 connector	570403
PSEN ml b 2.2 switch	Mechanical safety switch with guard locking, uniquely coded, for single connection	8-pin M12 connector	570405
PSEN ml DHM up l 1.1	Actuator with handle unit, coded	For switch with upward cable outlet Left-hinged door	6O000001
PSEN ml DHM up l 2.1	Actuator with handle unit, fully coded	For switch with upward cable outlet Left-hinged door	6O000002
PSEN ml DHM up r 1.1	Actuator with handle unit, coded	For switch with upward cable outlet Right-hinged door	6O000003
PSEN ml DHM up r 2.1	Actuator with handle unit, fully coded	For switch with upward cable outlet Right-hinged door	6O000004
PSEN ml DHM down l 1.1	Actuator with handle unit, coded	For switch with downward cable outlet Left-hinged door	6O000005
PSEN ml DHM down l 2.1	Actuator with handle unit, fully coded	For switch with downward cable outlet Left-hinged door	6O000006
PSEN ml DHM down r 1.1	Actuator with handle unit, coded	For switch with downward cable outlet Right-hinged door	6O000007
PSEN ml DHM down r 2.1	Actuator with handle unit, fully coded	For switch with downward cable outlet Right-hinged door	6O000008

20.2 Installation accessories

Installation accessories

Product type	Features	Order no.
PSEN ml escape release	Escape release stationary	570460
PSEN ml escape release extension	Extension escape release stationary 25 mm	570462
PSEN ml DHM extension	Extension for installing handle on gates wider than 40 mm	60000009
PSEN ml DHM handle yellow	Black handle with yellow grip insert for PSEN ml DHM down/up l/r x.x	60000010
PSEN ml DHM handle red	Black handle with red grip insert for PSEN ml DHM down/up l/r x.x (escape release handle)	60000011
PSEN ml DHM extension cover	Cover sleeves to conceal the extension sleeves	60000012
PSEN ml DHM mounting plate	Mounting plate for actuator PSEN ml DHM down/up l/r x.x	60000013
PSEN ml mounting plate	Mounting plate for installing the safety switch, with 4 hexagonal socket head screws and 1 tamper-proof pan head locking screw, M5x40	570490
PSEN ml DHM mounting flap	Mounting flaps for sliding gates	60000014

20.3 Cable accessories

Product type	Features	Connector X1	Connector X2	Connector X3	Order no.
PSEN cable axial M12 8-pole 3m	3 m	M12, 8-pin female connector, straight			540319
PSEN cable axial M12 8-pole 5m	5 m	M12, 8-pin female connector, straight			540320
PSEN cable axial M12 8-pole 10m	10 m	M12, 8-pin female connector, straight			540321
PSEN cable M12-8sf, 20m	20 m	M12, 8-pin female connector, straight			540333
PSEN cable axial M12 8-pole 30m	30 m	M12, 8-pin female connector, straight			540326
PSEN cable M12-8sf M12-8sm, 0.5m	0.5 m	M12, 8-pin female connector, straight	M12, 8-pin male connector, straight		540345

Product type	Features	Connector X1	Connector X2	Connector X3	Order no.
PSEN cable M12-8sf M12-8sm, 1m	1 m	M12, 8-pin fe- male con- nector, straight	M12, 8-pin male con- nector, straight		540346
PSEN cable M12-8sf M12-8sm, 1.5m	1.5 m	M12, 8-pin fe- male con- nector, straight	M12, 8-pin male con- nector, straight		540347
PSEN cable M12-8sf M12-8sm, 2m	2 m	M12, 8-pin fe- male con- nector, straight	M12, 8-pin male con- nector, straight		540340
PSEN cable M12-8sf M12-8sm, 5m	5 m	M12, 8-pin fe- male con- nector, straight	M12, 8-pin male con- nector, straight		540341
PSEN cable M12-8sf M12-8sm, 10m	10 m	M12, 8-pin fe- male con- nector, straight	M12, 8-pin male con- nector, straight		540342
PSEN cable M12-8sf M12-8sm, 20m	20 m	M12, 8-pin fe- male con- nector, straight	M12, 8-pin male con- nector, straight		540343
PSEN cable M12-8sf M12-8sm, 30m	30 m	M12, 8-pin fe- male con- nector, straight	M12, 8-pin male con- nector, straight		540344
PSEN ml / PSEncs Y junction M12		M12, 8-pin fe- male connector	M12, 8-pin male connector	M12, 8-pin fe- male connector	570489

22 **EC declaration of conformity**

This product/these products meet the requirements of the directive 2006/42/EC for machinery of the European Parliament and of the Council. The complete EC Declaration of Conformity is available on the Internet at www.pilz.com/downloads.

Authorised representative: Norbert Fröhlich, Pilz GmbH & Co. KG, Felix-Wankel-Str. 2, 73760 Ostfildern, Germany

