



Visualisation; Diagnostics

Easy to Configure

Programming IEC 61131-3

Rapid Installation

## PSEN sl-0.5p 1.1

# PILZ

THE SPIRIT OF SAFETY

► PSEN sensor technology

This document is the original document.

Where unavoidable, for reasons of readability, the masculine form has been selected when formulating this document. We do assure you that all persons are regarded without discrimination and on an equal basis.

All rights to this documentation are reserved by Pilz GmbH & Co. KG. Copies may be made for the user's internal purposes. Suggestions and comments for improving this documentation will be gratefully received.

Pilz®, PIT®, PMI®, PNOZ®, Primo®, PSEN®, PSS®, PVIS®, SafetyBUS p®, SafetyEYE®, SafetyNET p®, the spirit of safety® are registered and protected trademarks of Pilz GmbH & Co. KG in some countries.



SD means Secure Digital

<b>Introduction</b> .....	<b>5</b>
Validity of documentation .....	5
Using the documentation .....	5
Definition of symbols .....	5
<b>Safety</b> .....	<b>6</b>
Intended use .....	6
Safety regulations .....	7
Safety assessment .....	7
Use of qualified personnel .....	7
Warranty and liability .....	8
Disposal .....	8
For your safety .....	8
<b>Unit features</b> .....	<b>8</b>
<b>Function description</b> .....	<b>9</b>
Lateral and vertical offset .....	10
<b>Wiring</b> .....	<b>11</b>
Guidelines for cable length .....	11
Recommended cable cross sections .....	12
Pin assignment .....	12
<b>Connection to evaluation devices</b> .....	<b>13</b>
Connection example PNOZ s3 .....	16
Connection example PNOZmulti .....	17
<b>Teaching in the actuator</b> .....	<b>18</b>
PSEN sl-0.5p 1.1 .....	18
<b>Installation</b> .....	<b>18</b>
Note regarding the free-moving actuator PSEN sl-0.5fm .....	20
Installing on a swing gate .....	21
Installing on a sliding gate .....	22
<b>Adjustment</b> .....	<b>23</b>
<b>Operation</b> .....	<b>23</b>
Error display through flashing codes .....	24

<b>Dimensions in mm</b> .....	<b>26</b>
<b>Technical Details Order No. 570500</b> .....	<b>28</b>
<b>Technical Details Order No. 570560</b> .....	<b>31</b>
<b>Supplementary data</b> .....	<b>34</b>
Radio approval .....	34
<b>Safety characteristic data</b> .....	<b>34</b>
<b>Classification according to ZVEI, CB24I</b> .....	<b>35</b>
<b>Order reference</b> .....	<b>36</b>
Order reference for safety gate system .....	36
Accessories .....	36
<b>EC declaration of conformity</b> .....	<b>36</b>
<b>UKCA-Declaration of Conformity</b> .....	<b>36</b>

## Introduction

### Validity of documentation

This documentation is valid for the product PSEN sl-0.5p 1.1. It is valid until new documentation is published.

This operating manual explains the function and operation, describes the installation and provides guidelines on how to connect the product.

### Using the documentation

This document is intended for instruction. Only install and commission the product if you have read and understood this document. The document should be retained for future reference.

### Definition of symbols

Information that is particularly important is identified as follows:



#### **DANGER!**

This warning must be heeded! It warns of a hazardous situation that poses an immediate threat of serious injury and death and indicates preventive measures that can be taken.



#### **WARNING!**

This warning must be heeded! It warns of a hazardous situation that could lead to serious injury and death and indicates preventive measures that can be taken.



#### **CAUTION!**

This refers to a hazard that can lead to a less serious or minor injury plus material damage, and also provides information on preventive measures that can be taken.



#### **NOTICE**

This describes a situation in which the product or devices could be damaged and also provides information on preventive measures that can be taken. It also highlights areas within the text that are of particular importance.



### INFORMATION

This gives advice on applications and provides information on special features.





## Safety

### Intended use

Safety function of safety switch:

- ▶ 2 safety outputs supply a high signal each when the corresponding input is high and the actuator is in the switch's response range.

The safety gate system meets the requirements in accordance with

- ▶ EN 60947-5-3: PDDb with the corresponding actuator PSEN sl0.5 or PSEN sl0.5fm (see Technical details: [System with normal actuator](#)  28], [System with free-moving actuator](#)  31])
- ▶ EN 62061: SIL CL 3
- ▶ EN ISO 13849-1: PL e and Cat. 4
- ▶ EN ISO 14119: Coding level Low, Type 4
- ▶ The safety switch may only be used with the corresponding actuator (see Technical Details: [System with normal actuator](#)  28], [System with free-moving actuator](#)  31]).

The safety level PL e (Cat. 4)/SIL CL 3 is only achieved if

- ▶ the safety outputs use 2-channel processing.



### NOTICE

#### Positioning of the safety switch

As the safety switch is not intended for a guard locking device for personal protection, the safeguard monitored by the safety switch must be positioned in a way that the access time corresponds at least to the machine's stopping time.

Because of the low operating distance (see [Technical details](#)  28]) the repetition accuracy of 40 % deviates from the requirement in accordance with EN 60947-5-2 (max. 10%).

### Improper use

The following is deemed improper use in particular

- ▶ Any component, technical or electrical modification to the product,
- ▶ Use of the product outside the areas described in this operating manual,
- ▶ Use of the product outside the technical details (see [Technical details](#)  28]).

**NOTICE****EMC-compliant electrical installation**

The product is designed for use in an industrial environment. The product may cause interference if installed in other environments. If installed in other environments, measures should be taken to comply with the applicable standards and directives for the respective installation site with regard to interference.

**INFORMATION**

**The magnet surface and counterplate may heat up. When installing, make sure that heat dissipation is guaranteed.**

**Safety regulations****Safety assessment**

Before using a device, a safety assessment in accordance with the Machinery Directive is required.

The product as an individual component fulfils the functional safety requirements in accordance with EN ISO 13849 and EN 62061. However, this does not guarantee the functional safety of the overall plant/machine. To achieve the relevant safety level of the overall plant/machine's required safety functions, each safety function needs to be considered separately.

**Use of qualified personnel**

The products may only be assembled, installed, programmed, commissioned, operated, maintained and decommissioned by persons who are competent to do so.

A competent person is a qualified and knowledgeable person who, because of their training, experience and current professional activity, has the specialist knowledge required. To be able to inspect, assess and operate devices, systems and machines, the person has to be informed of the state of the art and the applicable national, European and international laws, directives and standards.

It is the company's responsibility only to employ personnel who

- ▶ Are familiar with the basic regulations concerning health and safety / accident prevention,
- ▶ Have read and understood the information provided in the section entitled Safety
- ▶ Have a good knowledge of the generic and specialist standards applicable to the specific application.

### Warranty and liability

All claims to warranty and liability will be rendered invalid if

- ▶ The product was used contrary to the purpose for which it is intended,
- ▶ Damage can be attributed to not having followed the guidelines in the manual,
- ▶ Operating personnel are not suitably qualified,
- ▶ Any type of modification has been made (e.g. exchanging components on the PCB boards, soldering work etc.).

### Disposal

- ▶ In safety-related applications, please comply with the mission time  $T_M$  in the safety-related characteristic data.
- ▶ When decommissioning, please comply with local regulations regarding the disposal of electronic devices (e.g. Electrical and Electronic Equipment Act).

### For your safety



#### **DANGER!**

#### **Risk to life due to manipulation/defeat of the safeguard**

If replacement actuators are obtained, these must be installed as described in the chapter entitled Installation.

If replacement actuators are used manipulatively or the function of the safeguard is defeated, there is a risk to life when operating the plant or machine! This must be considered in the operator's hazard assessment and the operator must define appropriate measures to exclude manipulation.

- ▶ Do not remove the connector's protective cap until you are just about to connect the unit. This will prevent potential contamination.

### Unit features

- ▶ Transponder technology for presence detection
- ▶ Device types Pilz coding type:
  - PSEN sl-0.5p 1.1: coded
- ▶ different actuators available (see [Order reference](#)  36)
  - Standard actuator PSEN sl-0.5
  - free-moving actuator PSEN sl-0.5fm for special applications with higher tolerance compensation
- ▶ Dual-channel operation
- ▶ 2 safety outputs
- ▶ 2 safety inputs for series connection of multiple safety switches
- ▶ 1 signal output
- ▶ Magnetic guard locking for process protection
- ▶ 1 input to switch the locking magnet on/off



- ▶ LEDs for
  - Supply voltage/fault
  - Gate closed
  - State of the inputs
  - State of the magnetic guard locking device
- ▶ M12, 8-pin male connector

### Function description

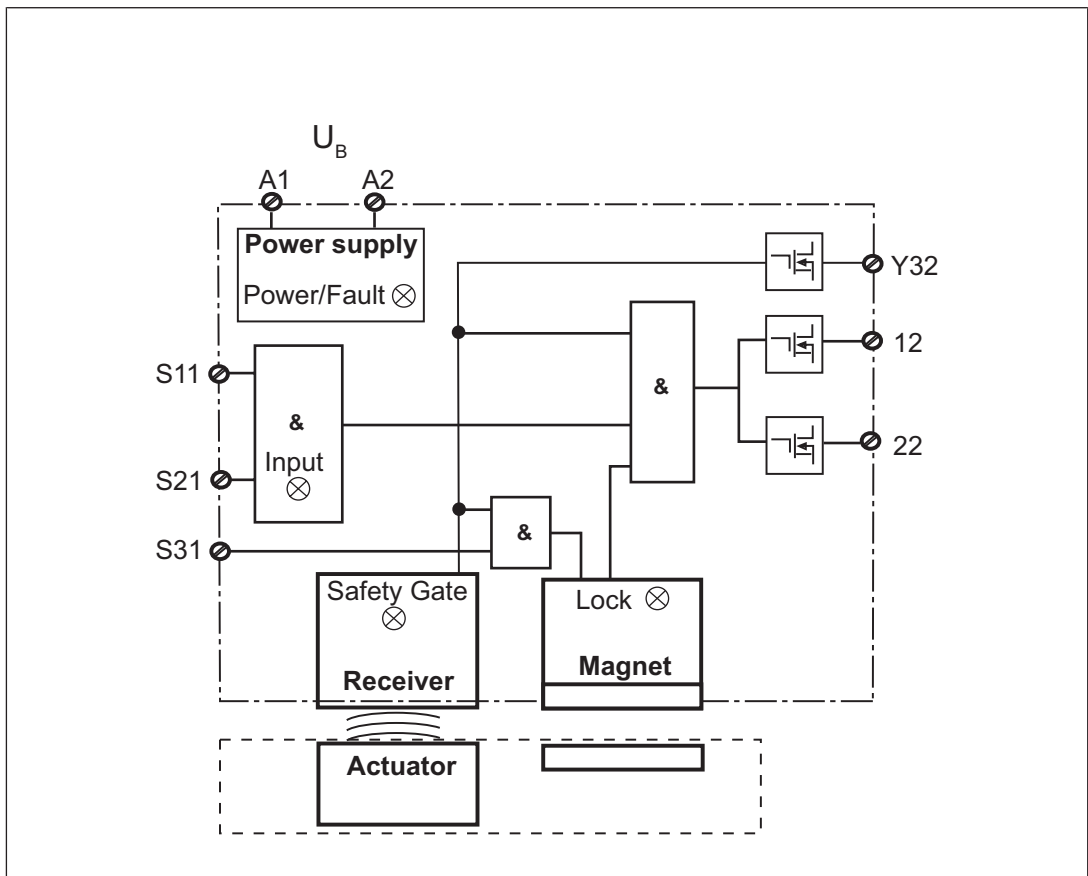

There is a high signal at safety outputs 12 and 22 if the following occur **simultaneously**:

- ▶ The actuator is within the response range (safety gate closed) and
- ▶ There is a high signal at the inputs S11 and S21 and
- ▶ There is a high signal at the input S31 (control command for magnetic guard locking) and
- ▶ The holding force of the locking magnet has been tested successfully.

There is a low signal at safety outputs 12 and 22 if **at least one** of the following conditions are met:

- ▶ The actuator is outside the response range or
- ▶ There is a low signal at the inputs S11 or S21 or
- ▶ There is a low signal at the input S31 (control command for magnetic guard locking) or
- ▶ The holding force of the locking magnet has not been tested successfully.

### Signal output Y32

There is a high signal at the signal output Y32 if the actuator is within the response range (safety gate closed).

### Plausibility monitoring for safety inputs S11 and S21

- ▶ If the signal at a safety input switches from high to low, while the other safety input remains high, an unequal status is displayed.
- ▶ If the signal at this input switches back from low to high, while a high signal remains at the other input, a plausibility error is displayed and a partial operation lock is triggered. The OSSDs are switched off during the partial operation lock.

A switch to a high signal will only lead to error-free safety switch operation if both inputs had a low signal simultaneously. From this moment on, the switch to high signal may occur (partial operation lock see [Error display](#) [📖 24]).

### Magnetic guard locking device and magnet monitoring

- ▶ The locking magnet is switched on if there is a high signal at input S31 (control command for magnetic guard locking) and the actuator is detected (safety gate closed).
- ▶ The holding force of the locking magnet is tested on power-up.
- ▶ After a signal change at the input S31 to low, wait for at least 500 ms, before supplying a high signal again at the input S31. Also note the max. switching frequency (see Technical details: [System with normal actuator](#) [📖 28], [System with free-moving actuator](#) [📖 31], under electrical data).

If an open winding or a winding short circuit is detected on a locking magnet that is switched on, safety outputs 12 and 22 switch to a low state.

- ▶ For physical reasons, a remanence (residual magnetism) remains after the locking magnet is switched off; this is dissipated the first time the sensor and actuator are separated. Therefore a higher effort is required when opening for the first time.
- ▶ If the safety gate is in a locked condition and is opened by force, the safety outputs will shut down.

### Lateral and vertical offset

- ▶ Max. vertical offset: 5 mm

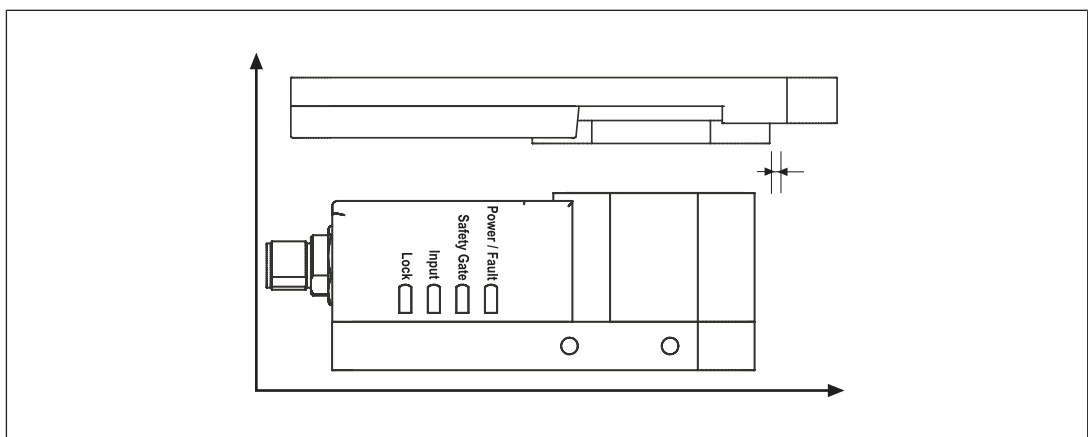

- ▶ Max. lateral offset: 3 mm

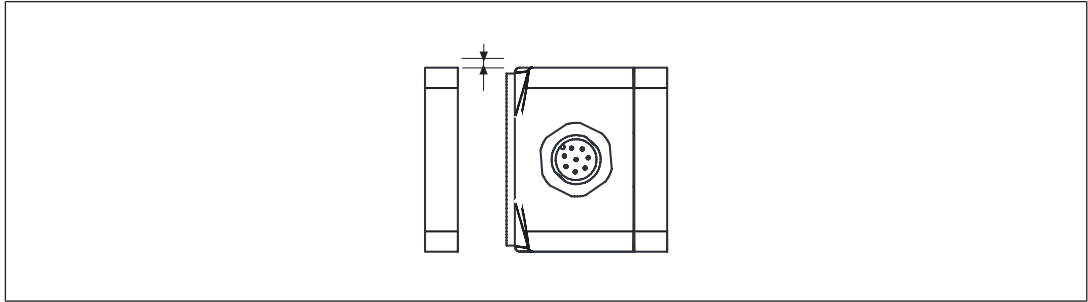

## Wiring

Please note:

- ▶ You must comply with the specifications stated in the technical details (see Technical details: [System with normal actuator \[28\]](#), [System with free-moving actuator \[31\]](#)).
- ▶ The power supply must meet the regulations for extra low voltages with protective electrical separation (SELV, PELV).
- ▶ The inputs and outputs of the safety switch must have protective separation from voltages over 60 VDC.
- ▶ Ensure the wiring and EMC requirements of EN 60204-1 are met.
- ▶ Make sure you comply with the wiring technology requirements (DIN EN 60204-1) and manipulation protection requirements (EN ISO 14119).

### Guidelines for cable length

The max. cable length depends on the voltage drop at the safety switches. The level of voltage drop is determined by the:

- ▶ Cable resistance
- ▶ Current of the device and the current load of the outputs

If the level of the supply voltage at the device connector falls below the minimum permitted value (see Technical details: [System with normal actuator \[28\]](#), [System with free-moving actuator \[31\]](#)), the locking magnet is no longer activated reliably. The "Lock" LED registers an error when guard locking.

Possible remedies:

- ▶ Set the supply voltage constantly to the upper tolerance range (see Technical details: [System with normal actuator \[28\]](#), [System with free-moving actuator \[31\]](#)).
- ▶ Select a higher conductor cross section
- ▶ Reduce load at the outputs, e.g. with evaluation device PNOZ e1.1p

### Recommended cable cross sections

Prerequisite:

- ▶ Supply voltage: 24 V
- ▶ Cable type: LiYY 8x0.25 mm<sup>2</sup> (79 Ohm/km) from Pilz

Max. load per safety output	100 mA	500 mA
Cable length	65 m	28 m

If cable lengths greater than those stated in the table are required, please contact Pilz.

### Pin assignment

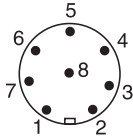
	8-pin M12 connector
---	---------------------

PIN	Function	Terminal designation	Cable colour (Pilz cable)
1	Input, channel 2	S21	White
2	+24 V UB	A1	Brown
3	Safety output channel 1	12	Green
4	Safety output channel 2	22	Yellow
5	Signal output	Y32	Grey
6	Input, channel 1	S11	Pink
7	0 V UB	A2	Blue
8	"Lock_Unlock"	S31	Red

The wire colour also applies for the cable available from Pilz as an accessory.

### Connection to evaluation devices

Make sure that the selected evaluation device has the following properties:

- ▶ 2-channel with feasibility monitoring
- ▶ OSSD signals are evaluated

#### Connection diagram, single connection

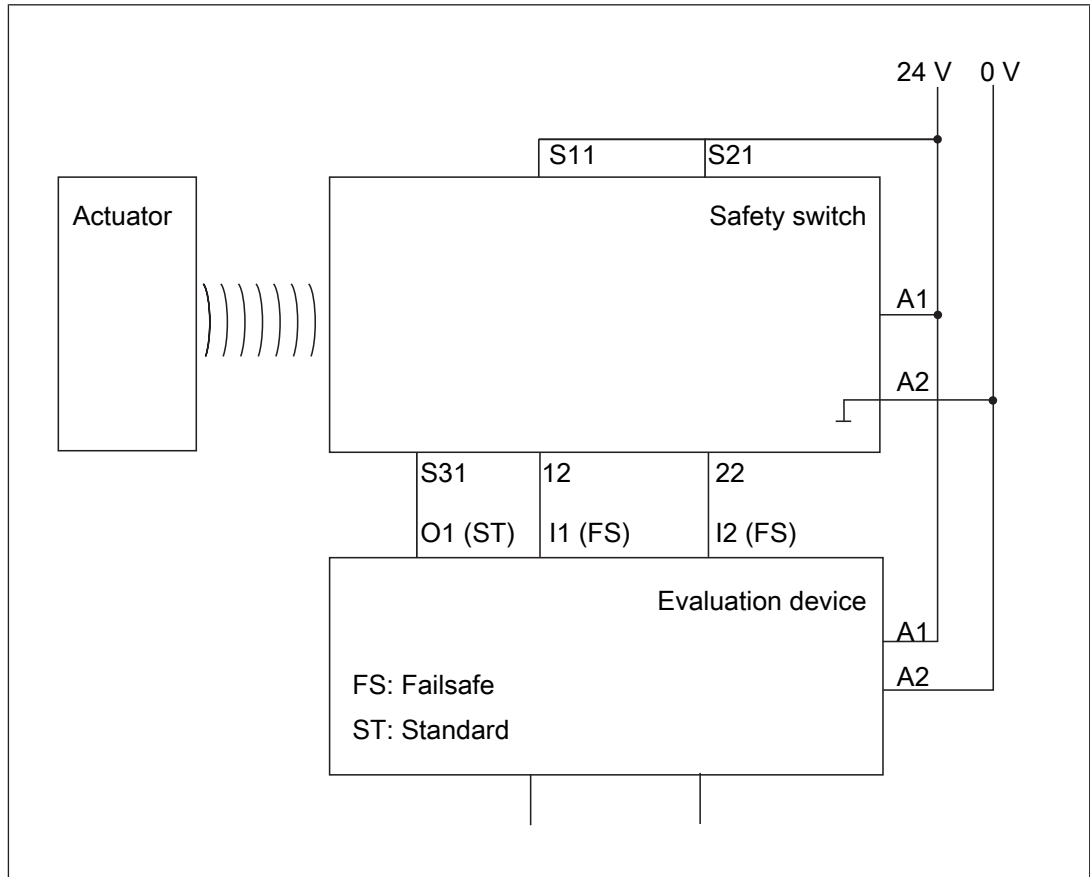

Connection diagram, series connection

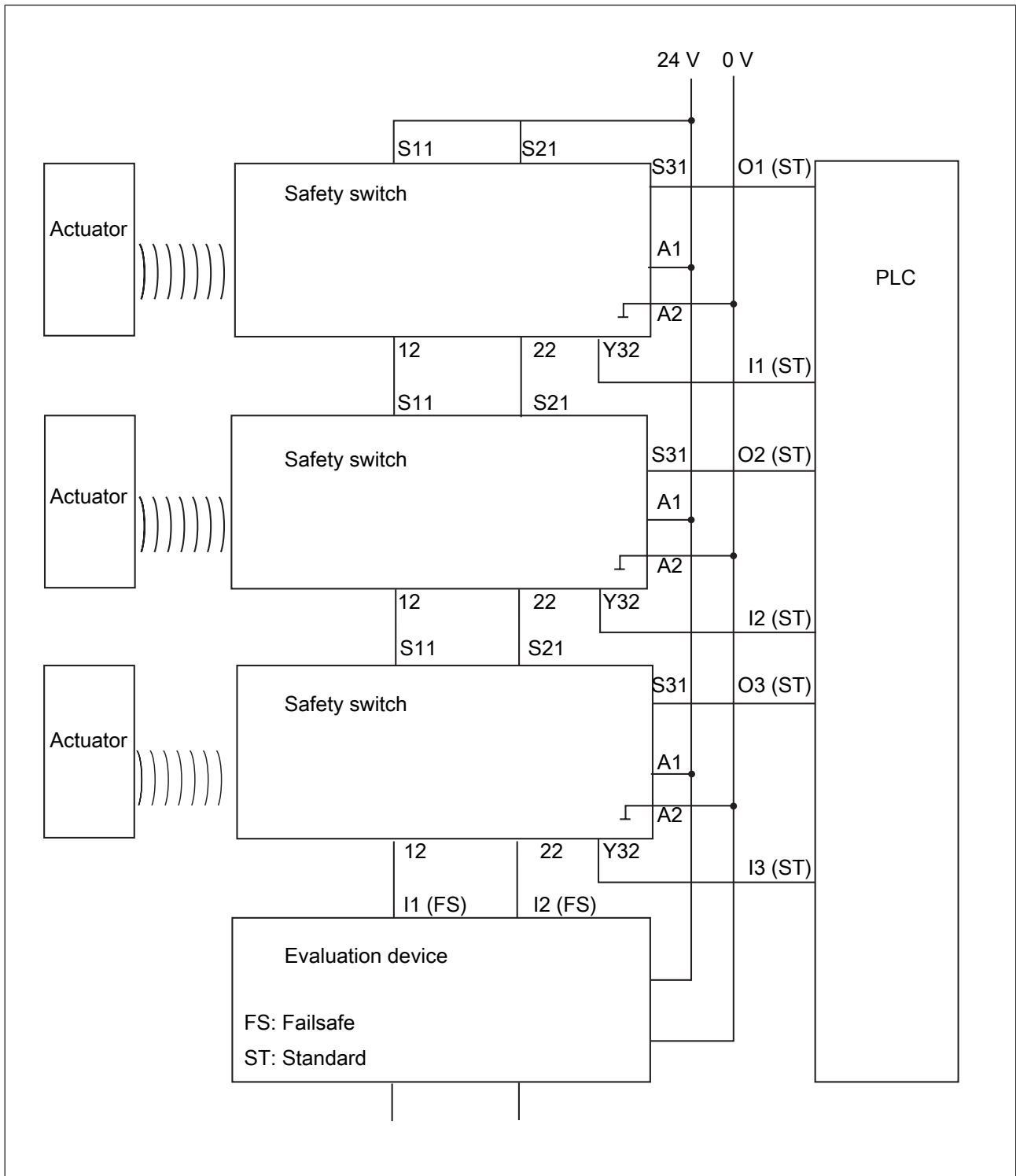

**CAUTION!****Extension of delay-on de-energisation**

When several (n) devices are connected in series, the delay-on de-energisation time adds with the number of interconnected safety switches. The may. delay-on de-energisation is composed of

- max. delay-on de-energisation actuator
- + (n-1) x max. delay-on de-energisation of the inputs
- + delay-on de-energisation of the evaluation device

**CAUTION!**

When several units are connected in series, the required current adds with the number of interconnected safety switches.

**Function test when safety channels are connected in series**

Before commissioning and after each change, check that the safety function is guaranteed when the gates are opened. To do this, open each gate individually and check the status at the inputs on the evaluation device:

- ▶ Close all the gates.
  - There must be high signals at the inputs on the evaluation device (e.g. S11, S21 or I1, I2).
- ▶ Open one gate; the other gates remain closed.
  - There must be low signals at the inputs on the evaluation device (e.g. S11, S21 or I1, I2).
- ▶ Close the gate again.
  - High signals must return at the inputs on the evaluation device (e.g. S11, S21 or I1, I2).
- ▶ Repeat the test for each gate.
- ▶ If the input signals do not react as described above, check and rectify the wiring and carry out the test again.

The safety switch PSEN sl-0.5p 1.1 can be connected to Pilz evaluation devices, for example.

Suitable Pilz evaluation devices are, for example:

- ▶ PNOZelog for safety gate monitoring
- ▶ PNOZpower for safety gate monitoring
- ▶ PNOZsigma for safety gate monitoring
- ▶ PNOZ X for safety gate monitoring
- ▶ PNOZmulti for safety gate monitoring  
Configure the safety switch in the PNOZmulti Configurator with switch type 3.
- ▶ PSS for safety gate monitoring with standard function block SB064, SB066 or FS\_Safety Gate

The correct connection to the respective evaluation device is described in the operating manual for the evaluation device. Make sure that the connection is made in accordance with the specifications in the operating manual for the selected evaluation device.

The connections to two evaluation devices are shown on the following pages, by way of example:

- ▶ PNOZ s3 and
- ▶ PNOZmulti

### Connection example PNOZ s3

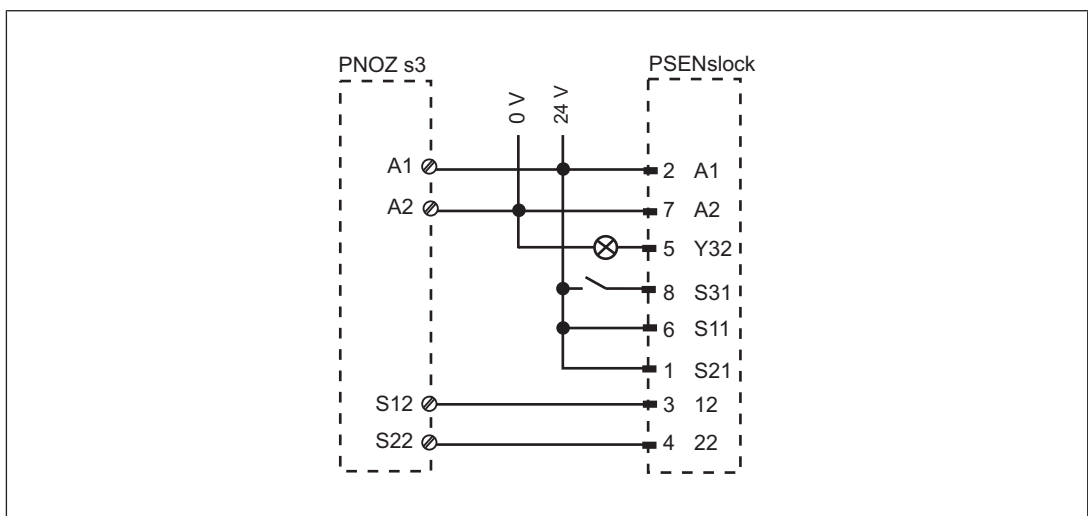



**Connection example PNOZmulti**

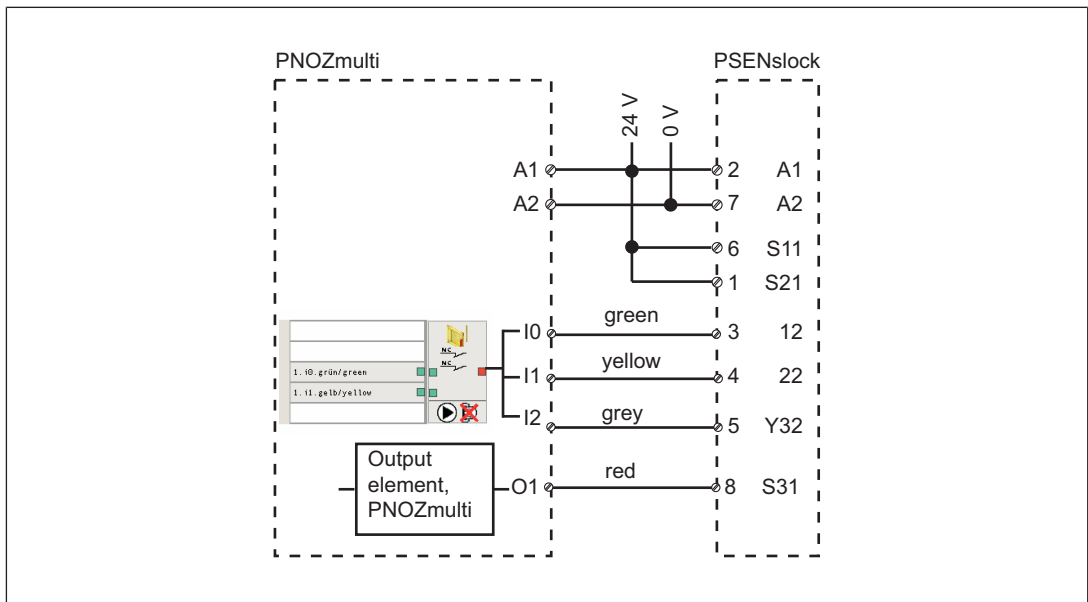

**Legend:**

I0	Input OSSD
I1	Input OSSD
I2	Signal input
O1	Lock/Unlock

## Teaching in the actuator

### PSEN sl-0.5p 1.1

Any corresponding Pilz actuator (see Technical details: [System with normal actuator](#) [📖 28], [System with free-moving actuator](#) [📖 31]) is detected as soon as it is brought into the response range.

## Installation

- ▶ The safety gate system can be installed on left or right-hinged swing gates or on sliding gates.



### WARNING!

#### Potential loss of safety function due to gross manipulation

Depending on the application, serious injury or death may result.

Use appropriate installation measures to prevent

- The wiring being modified.
- A short circuit being generated on the connector.
- The possibility of using a second actuator to open the safety gate.



### CAUTION!

The unit's properties may be affected if installed in an environment containing electrically or magnetically conductive material. Please check the operating distances and the assured release distance.

- ▶ Safety switches and actuators must be positioned so that they are secured against a change of position.
- ▶ Also note the max. angular offset (see Technical details: [System with normal actuator](#) [📖 28], [System with free-moving actuator](#) [📖 31]).
- ▶ The access to the safety switch and actuator has to be possible for maintenance and checking the correct operation.
- ▶ Use reliable fastening elements. A tool is to be required to loosen the fastening elements.
- ▶ Prevent self-loosening of the fastening elements of safety switch and actuator.
- ▶ The fastening of safety switch and actuator has to be sufficiently stable to ensure the proper operation of the safety switch and the actuator.
- ▶ Prevent the safety switch and actuator being exposed to heavy shock or vibration.
- ▶ Circumvention of the safety switch in a reasonably foreseeable manner must be prevented.

- ▶ Installation measures in accordance with EN ISO 14119
  - Use permanently secured safety screws with a flat head to attach the safety switch and the actuator (e.g. cheese-head or pan head screws) or rivets.
  - Installation of the safety switch and actuator must be concealed.
- ▶ Alignment errors of the guard must not adversely affect the safety function of the guard.



#### **INFORMATION**

Mounting brackets are available as [accessories](#) [ 36].

**Note regarding the free-moving actuator PSEN sl-0.5fm**

The free-moving actuators PSEN sl-0.5fm are fitted with a movable metal plate. For this reason, a recess must be provided in the mounting surface for the screw connection.

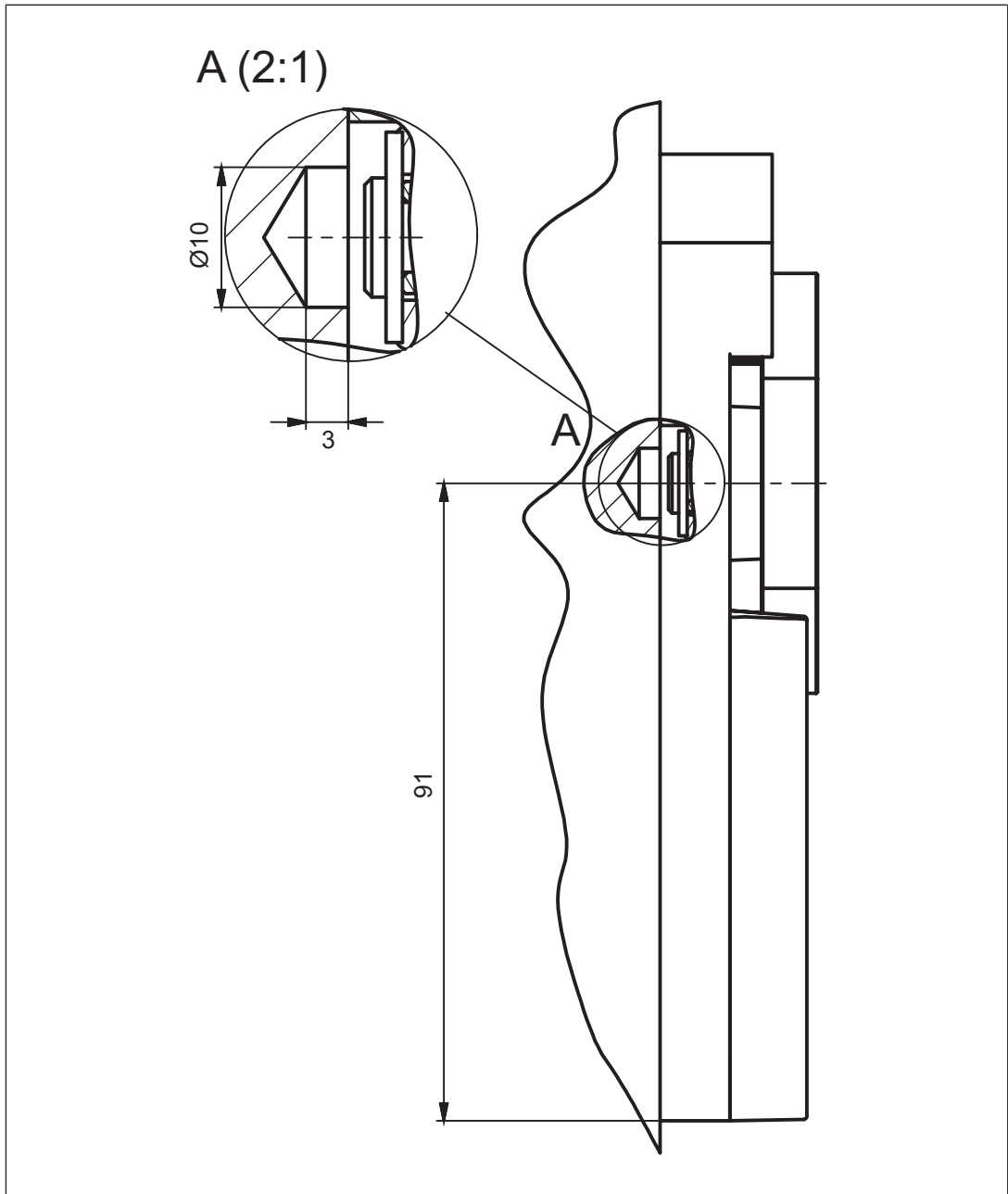

**WARNING!**

**Risk of death and serious injury by reaching into the danger zone!**

The actuators enable a warped gate to be closed. A gap may occur on the gate as a result. Make sure that the gap remains small enough to exclude the possibility of reaching into the danger zone.

### Installing on a swing gate

Align the actuator flush with the edge of the gate at the height required and tighten the screws.

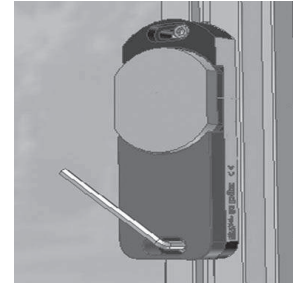

Close gate.

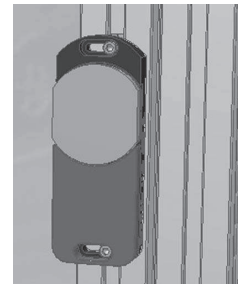

Align the mounting bracket flush with the safety switch and tighten the screws.



Align the safety switch and mounting bracket with the actuator and tighten the screws.

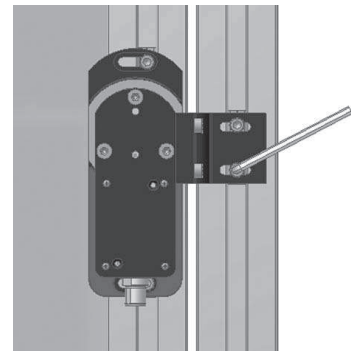

### Installing on a sliding gate

Align the actuator mounting bracket flush with the sliding gate and tighten the screws.

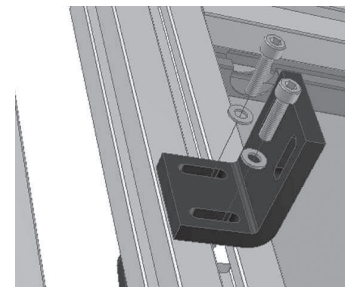

Install the actuator at the height required.

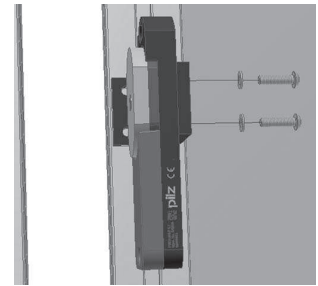

Align the safety switch mounting bracket flush with the frame and fasten with screws.

(Important: do not tighten the screws)

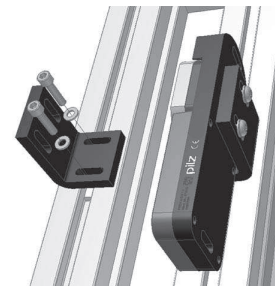

Fix safety switch upright with a screw (a), close gate.

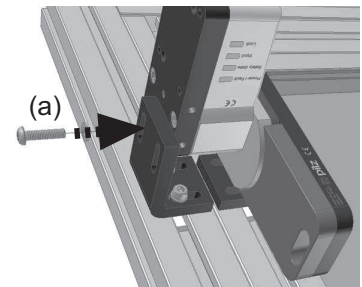

Align mounting brackets, press firmly together and tighten screw (b).

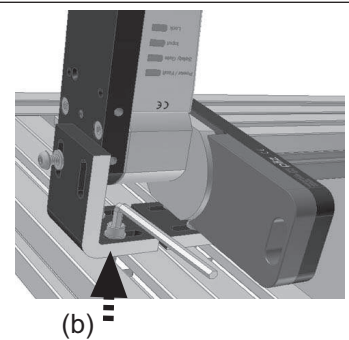

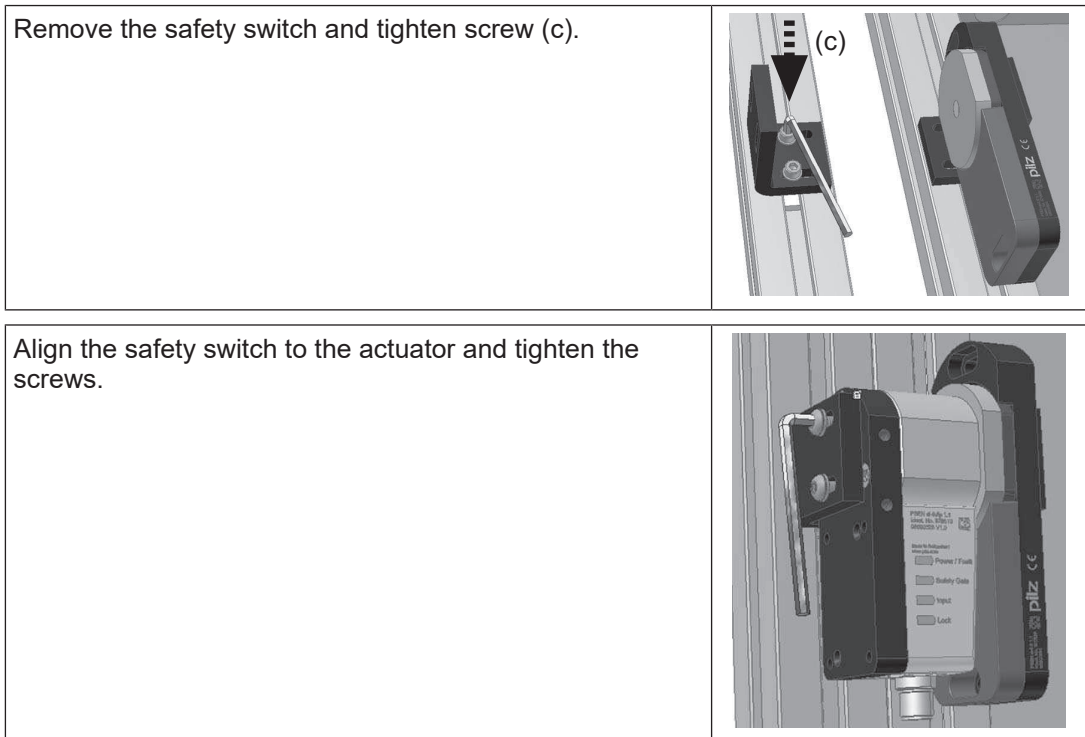

## Adjustment

- ▶ The stated operating distances (see Technical details: [System with normal actuator](#) [📖 28], [System with free-moving actuator](#) [📖 31]) only apply when the safety switch and actuator are installed facing each other in parallel. Operating distances may deviate if other arrangements are used.
- ▶ Note the maximum permitted lateral and vertical offset (see [Lateral and vertical offset](#) [📖 10]).

## Operation



### NOTICE

The safety functions should be checked after initial commissioning and each time the plant/machine is changed. The safety functions may only be checked by qualified personnel.



### CAUTION!

**Contaminated surfaces can reduce the holding force of the locking magnet.**

Make sure that the contact surfaces are clean.

**Status indicators:**

- ▶ "Power / Fault" LED illuminates green: The unit is ready for operation
- ▶ "Safety Gate" LED lights up yellow: Actuator is within the response range
- ▶ "Lock" LED lights up green: Magnetic guard locking device active
- ▶ "Input" LED lights up yellow: There is a high signal at the inputs.

**Error display through periodic flashing:**

- ▶ "Input" LED lights up yellow: the signal switches from high to low at one input, while a high signal remains on the other input (**partial operation**).  
Remedy: Open both channels of the input circuit.
- ▶ "Power/Fault" LED lights up red: Error message  
Flashing codes for fault diagnostics are output to the "Safety Gate" or "Input" LED (see Error display through flashing codes).  
Remedy: Rectify fault and interrupt power supply.
- ▶ "Lock" LED lights up red: Guard locking request is present, but guard locking has not taken place.  
This behaviour occurs, for example, when the safety gate is open or the actuator is not within the response range or the holding force is too low.  
Remedy: Rectify the cause (e.g. close safety gate), supply a low signal at input S31 and then supply a high signal again after at least 500 ms.

Please note the different times for

- ▶ The switch-on delay after UB is applied.

**Error display through flashing codes**

The "Safety Gate" and "Input" LEDs send flash signals; an error code can be established from the number and sequence. The "Power/Fault" LED illuminates red.

Each error code is indicated by three short flashes of the "Input" or "Safety Gate" LED. After a longer pause, the LED will then flash at one second intervals. The number of LED flashes corresponds to a digit in the error code. The error code can consist of up to 3 digits. The digits are separated by a longer period without flashing. The entire sequence is constantly repeated.

Number of flashes	1 2 3 4 5 6 7 8 9 10 11 12 13 14 15 16
Decimal error code	1 2 3 4 5 6 7 8 9 10 11 12 13 14 15 0

**Example:**

Error code 1,4,1:

Flash frequency of the "Safety Gate" or "Input" LED

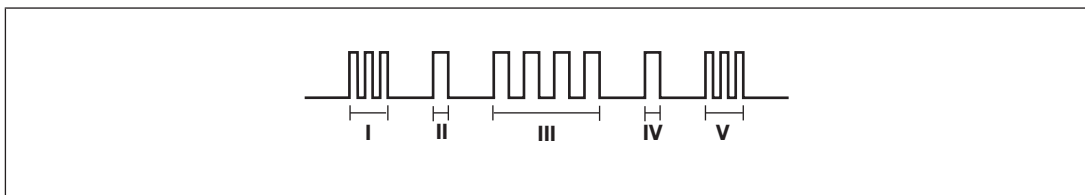



**Meaning of flash frequency:**

	Flash frequency	Meaning
I	3 times, short	Code for error message
II	Once, for one second each	Code for 1st digit
III	4 times, for one second each	Code for 2nd digit
IV	Once, for one second each	Code for 3rd digit
V	3 times, short	Code for error message repeated

**Table of error codes**

Error code Decimal	Number of flashes	Description	Remedy
1,4,1	3x short – 1x long – 4x long – 1x long – 3x short	Wiring errors at the inputs or outputs	Check the wiring of the inputs and outputs and rectify wiring errors
1,12	3x short – 1x long – 12x long – 3x short	Wiring error output 12	Check wiring output 12 and rectify wiring error
1,6,3	3x short – 1x long – 6x long – 3x long – 3x short	Wiring error output 12	Check wiring output 12 and rectify wiring error
1,13	3x short – 1x long – 12x long – 3x short	Wiring error output 22	Check wiring output 22 and rectify wiring error
1,6,4	3x short – 1x long – 6x long – 4x long – 3x short	Wiring error output 22	Check wiring output 22 and rectify wiring error
14	3x short – 14x long – 3x short	Wiring error output terminal 12 or capacitive load is too high (cable is too long)	Check wiring output 12 and rectify wiring error Check cable length and shorten it, if necessary (see max. cable length)
15	3x short – 15x long – 3x short	Wiring error output terminal 22 or capacitive load is too high (cable is too long)	Check wiring output 22 and rectify wiring error Check cable length and shorten it, if necessary (see max. cable length)

Other flashing codes signal an internal error. Remedy: Change device.

Dimensions in mm

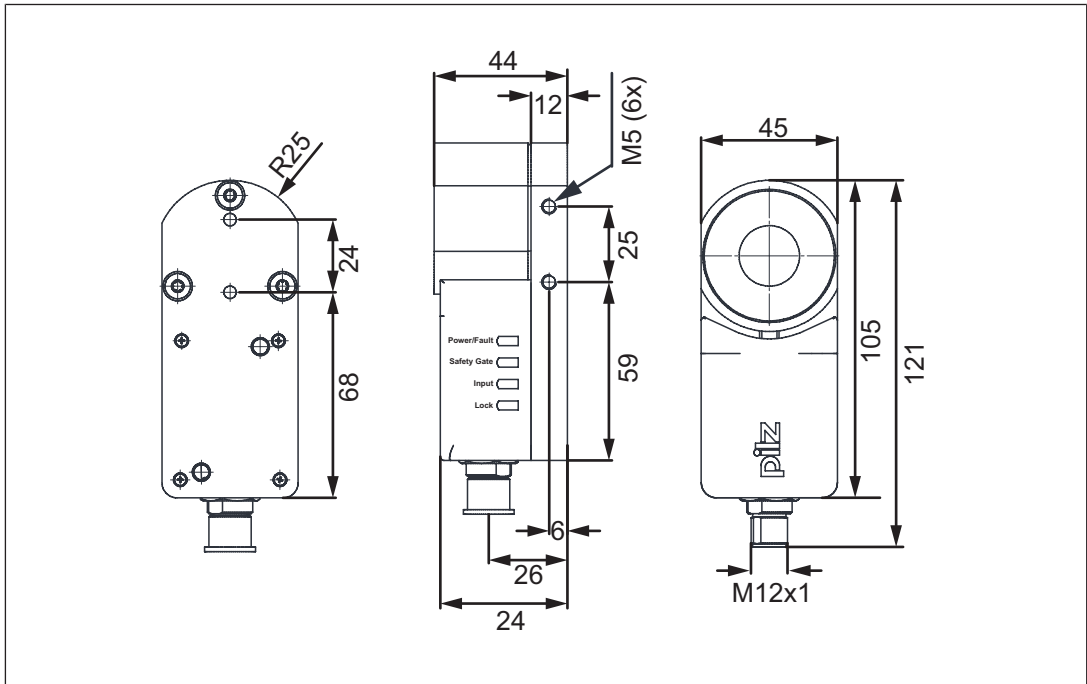

Fig.: Safety switch and locking magnet

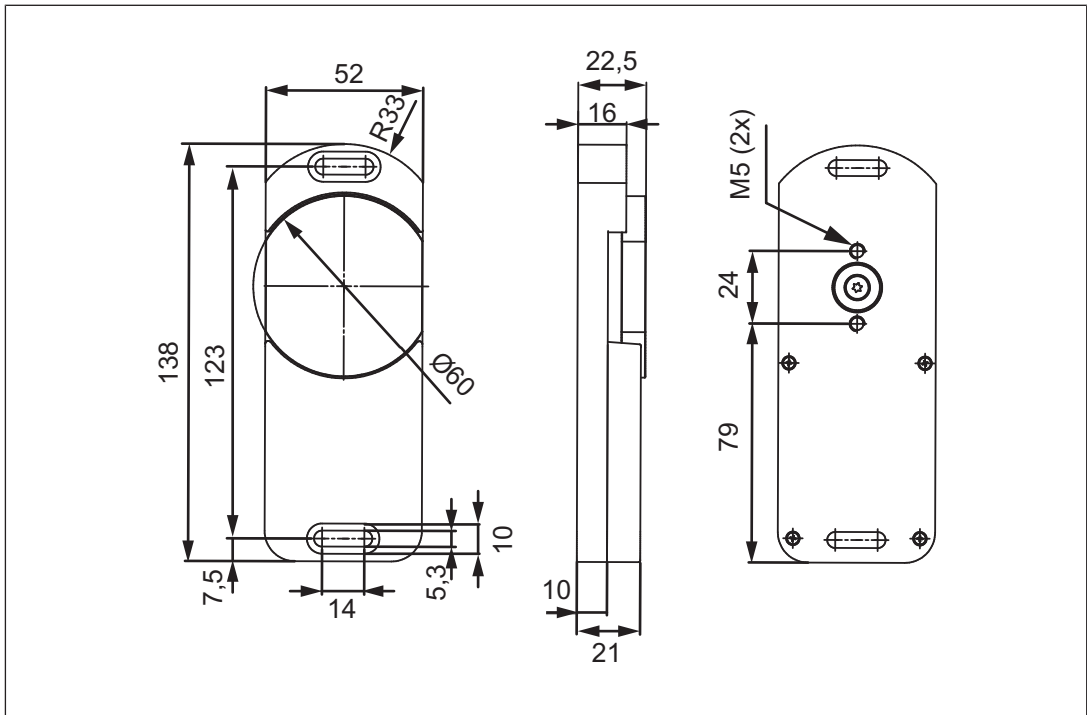

Fig.: Actuator

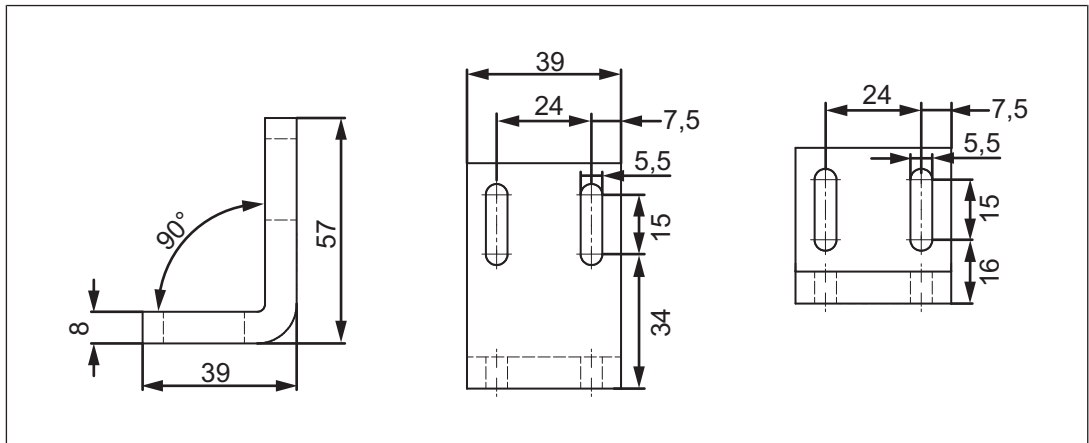

Fig.: Mounting bracket for sliding gate (see [Accessories](#) [36])

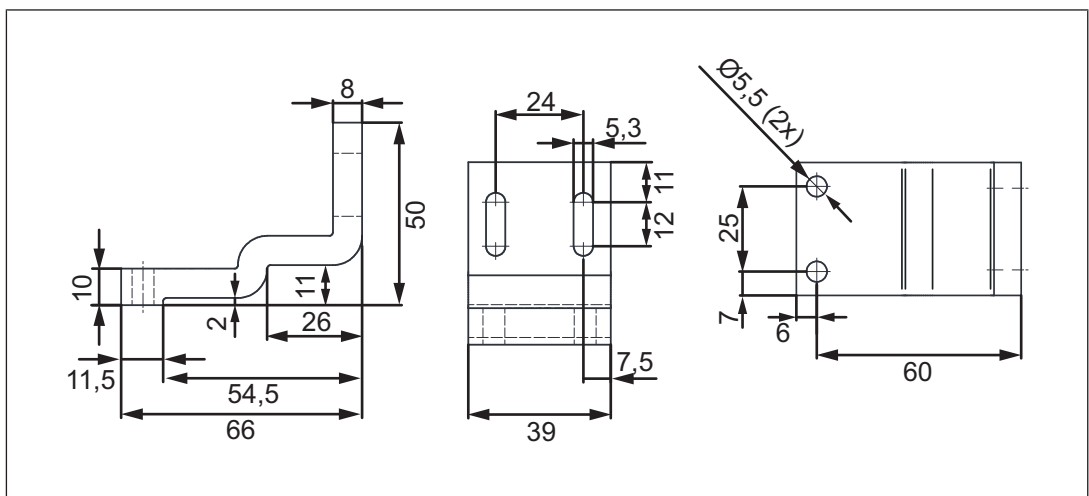

Fig.: Mounting bracket for swing gate (see [Accessories](#) [36])

## Technical Details Order No. 570500

<b>General</b>	
Certifications	<b>CE, EAC, FCC, IC, TÜV, UKCA, cULus Listed</b>
Sensor's mode of operation	<b>Transponder</b>
Coding level in accordance with EN ISO 14119	<b>Low</b>
Design in accordance with EN ISO 14119	<b>4</b>
Classification in accordance with EN 60947-5-3	<b>PDDb</b>
Pilz coding type	<b>Coded</b>
<b>Transponder</b>	
Frequency band	<b>122 kHz - 128 kHz</b>
Max. transmitter output	<b>15 mW</b>
<b>Electrical data</b>	
Supply voltage	
Voltage	<b>24 V</b>
Kind	<b>DC</b>
Voltage tolerance	<b>-15 %/+10 %</b>
Output of external power supply (DC)	<b>4,8 W</b>
Max. inrush current at UB	<b>0,6 A</b>
Max. switching frequency	<b>1 Hz</b>
Max. cable capacitance at the safety outputs	
No-load, PNOZ with relay contacts	<b>40 nF</b>
PNOZmulti, PNOZelog, PSS	<b>70 nF</b>
No-load current	<b>40 mA</b>
<b>Inputs</b>	
Number	<b>3</b>
Voltage at inputs	<b>24 V DC</b>
Input current range	<b>5 mA</b>
<b>Semiconductor outputs</b>	
Number of OSSD safety outputs	<b>2</b>
Signal outputs	<b>1</b>
Switching current per output	<b>500 mA</b>
Breaking capacity per output	<b>12 W</b>
Short circuit-proof	<b>yes</b>
Residual current at outputs	<b>250 µA</b>
Voltage drop at OSSDs	<b>1,5 V</b>
Conditional rated short circuit current	<b>100 A</b>
Lowest operating current	<b>0 mA</b>
Utilisation category in accordance with EN 60947-1	<b>DC-12</b>
<b>Times</b>	
Test pulse duration, safety outputs	<b>450 µs</b>

**Times**

Switch-on delay	
after UB is applied	<b>1,6 s</b>
Inputs typ.	<b>20 ms</b>
Inputs max.	<b>35 ms</b>
Actuator typ.	<b>500 ms</b>

Delay-on de-energisation	
Inputs typ.	<b>20 ms</b>
Inputs max.	<b>35 ms</b>
Actuator typ.	<b>25 ms</b>
Actuator max.	<b>260 ms</b>

Risk time in accordance with EN 60947-5-3	<b>260 ms</b>
---	---------------

Supply interruption before de-energisation	<b>15 ms</b>
--	--------------

Simultaneity, channel 1 and 2 max.	$\infty$
------------------------------------	----------

**Environmental data**

Temperature of metal surface at ambient temperature: 25 °C	<b>35 °C</b>
--	--------------

Ambient temperature	
In accordance with the standard	<b>EN 60068-2-14</b>
Temperature range	<b>-25 - 55 °C</b>

Storage temperature	
In accordance with the standard	<b>EN 60068-2-1/-2</b>
Temperature range	<b>-25 - 70 °C</b>

Climatic suitability	
In accordance with the standard	<b>EN 60068-2-78</b>
Humidity	<b>93 % r. h. at 40 °C</b>

EMC	<b>EN 55011: class A, EN 60947-5-3, EN 62061</b>
-----	--

Vibration	
In accordance with the standard	<b>EN 60947-5-2</b>
Frequency	<b>10 - 55 Hz</b>
Amplitude	<b>1 mm</b>

Shock stress	
In accordance with the standard	<b>EN 60068-2-27</b>
Number of shocks	<b>3</b>
Acceleration	<b>30g</b>
Duration	<b>11 ms</b>
In accordance with the standard	<b>EN 60068-2-27</b>
Number of shocks	<b>500</b>
Acceleration	<b>10g</b>
Duration	<b>16 ms</b>

Airgap creepage	
Overvoltage category	<b>III</b>
Pollution degree	<b>3</b>

Rated insulation voltage	<b>75 V</b>
--------------------------	-------------

Rated impulse withstand voltage	<b>1 kV</b>
---------------------------------	-------------

<b>Environmental data</b>	
Protection type	
Housing	<b>IP67</b>
<b>Operating distances</b>	
Assured operating distance $S_{ao}$	<b>1 mm</b>
Typical operating distance $S_o$	<b>2 mm</b>
Assured release distance $S_{ar}$	<b>8 mm</b>
Repetition accuracy switching distances	<b>40 %</b>
Typ. Hysteresis	<b>0,7 mm</b>
<b>Mechanical data</b>	
Holding force FZ <sub>h</sub> in accordance with ISO 14119	<b>450 N</b>
Magnetic holding force on	<b>500 N</b>
Magnetic holding force off	<b>20 N</b>
Max. vertical offset	<b>5 mm</b>
Max. lateral offset	<b>3 mm</b>
Max. angular offset	<b>2,5 deg</b>
Actuator 1	<b>PSEN sl-0.5 1.1</b>
Min. distance between safety switches	<b>30 mm</b>
Sensor flush installation in accordance with EN 60947-5-2	<b>yes, follow installation guidelines</b>
Connection type	<b>M12, 8-pin male connector</b>
Cable	<b>LiYY 8 x 0.25 mm<sup>2</sup></b>
Material	
Top	<b>PBT</b>
Anchor plate	<b>Nickel-plated steel</b>
Base plate	<b>Anticorodal, hard anodised</b>
Actuator	<b>Anticorodal, hard anodised</b>
Max. torque setting for fixing screws	<b>3 Nm</b>
Dimensions	
Height	<b>122 mm</b>
Width	<b>45 mm</b>
Depth	<b>44 mm</b>
Actuator dimensions	
Height	<b>138 mm</b>
Width	<b>52 mm</b>
Depth	<b>23 mm</b>
Weight of safety switch	<b>570 g</b>
Weight of actuator	<b>375 g</b>
Weight	<b>950 g</b>

Where standards are undated, the 2015-04 latest editions shall apply.

## Technical Details Order No. 570560

<b>General</b>	
Certifications	<b>CE, EAC, FCC, IC, TÜV, UKCA, cULus Listed</b>
Sensor's mode of operation	<b>Transponder</b>
Coding level in accordance with EN ISO 14119	<b>Low</b>
Design in accordance with EN ISO 14119	<b>4</b>
Classification in accordance with EN 60947-5-3	<b>PDDb</b>
Pilz coding type	<b>Coded</b>
<b>Transponder</b>	
Frequency band	<b>122 kHz - 128 kHz</b>
Max. transmitter output	<b>15 mW</b>
<b>Electrical data</b>	
Supply voltage	
Voltage	<b>24 V</b>
Kind	<b>DC</b>
Voltage tolerance	<b>-15 %/+10 %</b>
Output of external power supply (DC)	<b>4,8 W</b>
Max. inrush current at UB	<b>0,6 A</b>
Max. switching frequency	<b>1 Hz</b>
Max. cable capacitance at the safety outputs	
No-load, PNOZ with relay contacts	<b>40 nF</b>
PNOZmulti, PNOZelog, PSS	<b>70 nF</b>
No-load current	<b>40 mA</b>
<b>Inputs</b>	
Number	<b>3</b>
Voltage at inputs	<b>24 V DC</b>
Input current range	<b>5 mA</b>
<b>Semiconductor outputs</b>	
Number of OSSD safety outputs	<b>2</b>
Signal outputs	<b>1</b>
Switching current per output	<b>500 mA</b>
Breaking capacity per output	<b>12 W</b>
Short circuit-proof	<b>yes</b>
Residual current at outputs	<b>250 µA</b>
Voltage drop at OSSDs	<b>1,5 V</b>
Conditional rated short circuit current	<b>100 A</b>
Lowest operating current	<b>0 mA</b>
Utilisation category in accordance with EN 60947-1	<b>DC-12</b>
<b>Times</b>	
Test pulse duration, safety outputs	<b>450 µs</b>

**Times**

Switch-on delay	
after UB is applied	<b>1,6 s</b>
Inputs typ.	<b>20 ms</b>
Inputs max.	<b>35 ms</b>
Actuator typ.	<b>500 ms</b>

Delay-on de-energisation	
Inputs typ.	<b>20 ms</b>
Inputs max.	<b>35 ms</b>
Actuator typ.	<b>25 ms</b>
Actuator max.	<b>260 ms</b>

Risk time in accordance with EN 60947-5-3	<b>260 ms</b>
---	---------------

Supply interruption before de-energisation	<b>15 ms</b>
--	--------------

Simultaneity, channel 1 and 2 max.	$\infty$
------------------------------------	----------

**Environmental data**

Temperature of metal surface at ambient temperature: 25 °C	<b>35 °C</b>
--	--------------

Ambient temperature	
In accordance with the standard	<b>EN 60068-2-14</b>
Temperature range	<b>-25 - 55 °C</b>

Storage temperature	
In accordance with the standard	<b>EN 60068-2-1/-2</b>
Temperature range	<b>-25 - 70 °C</b>

Climatic suitability	
In accordance with the standard	<b>EN 60068-2-78</b>
Humidity	<b>93 % r. h. at 40 °C</b>

EMC	<b>EN 55011: class A, EN 60947-5-3, EN 62061</b>
-----	--

Vibration	
In accordance with the standard	<b>EN 60947-5-2</b>
Frequency	<b>10 - 55 Hz</b>
Amplitude	<b>1 mm</b>

Shock stress	
In accordance with the standard	<b>EN 60068-2-27</b>
Number of shocks	<b>3</b>
Acceleration	<b>30g</b>
Duration	<b>11 ms</b>
In accordance with the standard	<b>EN 60068-2-27</b>
Number of shocks	<b>500</b>
Acceleration	<b>10g</b>
Duration	<b>16 ms</b>

Airgap creepage	
Overvoltage category	<b>III</b>
Pollution degree	<b>3</b>

Rated insulation voltage	<b>75 V</b>
--------------------------	-------------

Rated impulse withstand voltage	<b>1 kV</b>
---------------------------------	-------------



<b>Environmental data</b>	
Protection type	
Housing	<b>IP67</b>
<b>Operating distances</b>	
Assured operating distance $S_{ao}$	<b>1 mm</b>
Typical operating distance $S_o$	<b>2 mm</b>
Assured release distance $S_{ar}$	<b>8 mm</b>
Repetition accuracy switching distances	<b>40 %</b>
Typ. Hysteresis	<b>0,7 mm</b>
<b>Mechanical data</b>	
Holding force FZ <sub>h</sub> in accordance with ISO 14119	<b>450 N</b>
Magnetic holding force on	<b>500 N</b>
Magnetic holding force off	<b>20 N</b>
Max. vertical offset	<b>5 mm</b>
Max. lateral offset	<b>3 mm</b>
Max. angular offset	<b>2,5 deg</b>
Actuator 1	<b>PSEN sl-0.5fm 1.1</b>
Min. distance between safety switches	<b>30 mm</b>
Sensor flush installation in accordance with EN 60947-5-2	<b>yes, follow installation guidelines</b>
Connection type	<b>M12, 8-pin male connector</b>
Cable	<b>LiYY 8 x 0.25 mm<sup>2</sup></b>
Material	
Top	<b>PBT</b>
Anchor plate	<b>Nickel-plated steel</b>
Base plate	<b>Anticorodal, hard anodised</b>
Actuator	<b>Anticorodal, hard anodised</b>
Max. torque setting for fixing screws	<b>3 Nm</b>
Dimensions	
Height	<b>122 mm</b>
Width	<b>45 mm</b>
Depth	<b>44 mm</b>
Actuator dimensions	
Height	<b>138 mm</b>
Width	<b>52 mm</b>
Depth	<b>23 mm</b>
Weight of safety switch	<b>570 g</b>
Weight of actuator	<b>365 g</b>
Weight	<b>940 g</b>

Where standards are undated, the 2015-04 latest editions shall apply.

## Supplementary data

### Radio approval

**USA/Canada**

**FCC ID: VT8-PSENSLP**  
**IC: 7482A-PSENSLP**

FCC/IC-Requirements:  
 This product complies with Part 15 of the FCC Rules and with Industry Canada licence-exempt RSS standards. Operation is subject to the following two conditions:  
 1) this product may not cause harmful interference, and  
 2) this product must accept any interference received, including interference that may cause undesired operation.

Changes or modifications made to this product not expressly approved by Pilz may void the FCC authorization to operate this equipment.

NOTE: This equipment has been tested and found to comply with the limits for a Class A digital device, pursuant to Part 15 of the FCC Rules. These limits are designed to provide reasonable protection against harmful interference when the equipment is operated in a commercial environment. This equipment generates, uses, and can radiate radio frequency energy and, if not installed and used in accordance with the instruction manual, may cause harmful interference to radio communications. Operation of this equipment in a residential area is likely to cause harmful interference in which case the user will be required to correct the interference at his own expense.

Le présent produit est conforme aux CNR d'Industrie Canada applicables aux appareils radio exempts de licence. L'exploitation est autorisée aux deux conditions suivantes:  
 (1) le produit ne doit pas produire de brouillage, et  
 (2) l'utilisateur de le produit doit accepter tout brouillage radioélectrique subi, même si le brouillage est susceptible d'en compromettre le fonctionnement.

### Safety characteristic data



**NOTICE**

You must comply with the safety characteristic data in order to achieve the required safety level for your plant/machine.

Operating mode	EN ISO 13849-1: 2015 PL	EN ISO 13849-1: 2015 Category	EN IEC 62061 SIL CL/ maximum SIL	EN IEC 62061 PFH <sub>0</sub> [1/h]	EN/IEC 61511 SIL	EN/IEC 61511 PFD	EN ISO 13849-1: 2015 T <sub>M</sub> [year]
2-ch. OSSD	PL e	Cat. 4	SIL CL 3	3,29E-09	SIL 3	1,72E-04	20

Explanatory notes for the safety-related characteristic data:

- ▶ Safety characteristic data in accordance with EN IEC 62061 and EN/IEC 61511 was calculated based on EN/IEC 61508.
- ▶ T<sub>M</sub> is the maximum mission time in accordance with EN ISO 13849-1. The value also applies as the retest interval in accordance with EN/IEC 61508-6 and EN/IEC 61511 and as the proof test interval and mission time in accordance with EN IEC 62061.

All the units used within a safety function must be considered when calculating the safety characteristic data.



**INFORMATION**

A safety function's SIL/PL values are **not** identical to the SIL/PL values of the units that are used and may be different. We recommend that you use the PAScal software tool to calculate the safety function's SIL/PL values.

**Classification according to ZVEI, CB24I**

The following tables describe the classes and specific values of the product interface and the classes of interfaces compatible with it. The classification is described in the ZVEI position paper "Classification of Binary 24 V Interfaces - Functional Safety aspects covered by dynamic testing".

**Input**

Interfaces	
Drain	
Interface	Sensor
Class	C2
Source	
Class	C2, C3
Drain parameters	
Max. test pulse duration	0,5 ms
Min. test pulse interval	2 ms
Min. input resistance	4,4 kOhm
Max. capacitive load	1 nF

**Single-pole output**

Interfaces	
Source	
Interface	Sensor
Class	C2
Drain	
Interface	Evaluation device
Class	C1, C2
Source parameters	
Max. test pulse duration	500 µs
Max. rated current	0,1 A
Max. capacitive load	0,07 µF

## Order reference

### Order reference for safety gate system

Product type	Features	Connection type	Order no.
PSEN sl-0.5p 1.1 / PSEN sl-0.5 1 unit	Safety gate system, coded	M12, 8-pin connector	570500
PSEN sl-0.5p 1.1 / PSEN sl-0.5fm 1 unit	Safety gate system, coded, with free-moving actuator	M12, 8-pin connector	570560

### Accessories

Product type	Features	Order no.
PSEN sl bracket swing door	Mounting bracket for swing gates and folding gates	570550
PSEN sl bracket sliding door	Mounting bracket for sliding gates	570551
PSEN sl restart interlock	Add-on module for the safety gate systems PSENslock and PSENsl2	570552

### EC declaration of conformity

This product/these products meet the requirements of the directive 2006/42/EC for machinery of the European Parliament and of the Council. The complete EC Declaration of Conformity is available on the Internet at [www.pilz.com/downloads](http://www.pilz.com/downloads).

Authorised representative: Norbert Fröhlich, Pilz GmbH & Co. KG, Felix-Wankel-Str. 2, 73760 Ostfildern, Germany

### UKCA-Declaration of Conformity

This product(s) complies with following UK legislation: Supply of Machinery (Safety) Regulation 2008.

The complete UKCA Declaration of Conformity is available on the Internet at [www.pilz.com/downloads](http://www.pilz.com/downloads).

Representative: Pilz Automation Technology, Pilz House, Little Colliers Field, Corby, Northamptonshire, NN18 8TJ United Kingdom, eMail: [mail@pilz.co.uk](mailto:mail@pilz.co.uk)

# ► Support

Technical support is available from Pilz round the clock.

## Americas

### Brazil

+55 11 97569-2804

### Canada

+1 888 315 7459

### Mexico

+52 55 5572 1300

### USA (toll-free)

+1 877-PILZUSA (745-9872)

## Asia

### China

+86 21 60880878-216

### Japan

+81 45 471-2281

### South Korea

+82 31 778 3300

## Australia and Oceania

### Australia

+61 3 95600621

### New Zealand

+64 9 6345350

## Europe

### Austria

+43 1 7986263-0

### Belgium, Luxembourg

+32 9 3217570

### France

+33 3 88104003

### Germany

+49 711 3409-444

### Ireland

+353 21 4804983

### Italy, Malta

+39 0362 1826711

## Scandinavia

+45 74436332

## Spain

+34 938497433

## Switzerland

+41 62 88979-32

## The Netherlands

+31 347 320477

## Turkey

+90 216 5775552

## United Kingdom

+44 1536 462203

## You can reach our international hotline on:

+49 711 3409-222

support@pilz.com

Pilz develops environmentally-friendly products using ecological materials and energy-saving technologies. Offices and production facilities are ecologically designed, environmentally-aware and energy-saving. So Pilz offers sustainability, plus the security of using energy-efficient products and environmentally-friendly solutions.



We are represented internationally. Please refer to our homepage [www.pilz.com](http://www.pilz.com) for further details or contact our headquarters.

Headquarters: Pilz GmbH & Co. KG, Felix-Wankel-Straße 2, 73760 Ostfildern, Germany  
Telephone: +49 711 3409-0, Telefax: +49 711 3409-133, E-Mail: [info@pilz.com](mailto:info@pilz.com), Internet: [www.pilz.com](http://www.pilz.com)

**PILZ**  
THE SPIRIT OF SAFETY

CECE®, CHRE®, CMSE®, InduraNET p®, Leansafe®, Master of Safety®, Master of Security®, PAS4000®, PAScall®, PASconfig®, Pilz®, PTT®, PLID®, PMCprimo®, PMCprotego®, PMClendo®, PMD®, PMJ®, PNOZ®, PRBM®, PRCM®, PSEN®, PSENi®, PSS®, PVS®, SafetyBUS p®, SafetyEYE®, SafetyNET p®, THE SPIRIT OF SAFETY® are registered and protected trademarks of Pilz GmbH & Co. KG in some countries. We would point out that product features may vary from the details stated in this document, depending on the status at the time of publication and the scope of the equipment. We accept no responsibility for the validity, accuracy and entirety of the text and graphics presented in this information. Please contact our Technical Support if you have any questions.

21904-EN-12, 2022-11 Printed in Germany  
© Pilz GmbH & Co. KG, 2019